

# TD Terrassendach

## TDa

PROFIELOVERZICHT .....	5
APERCU DES PROFILES	
PROFILUEBERSICHT	
PROFILE OVERVIEW	

## TDb

TOEBEHOREN .....	25
ACCESSOIRES	
ZUBEHORTEILE	
ACCESSORIES	

## TDc

STATICA .....	43
STATIQUE	
STATIK	
STATICS	

## TDd

DOORSNEDETEKENINGEN.....	75
SECTION DE NOEUDS	
PROFILKOMBINATIONEN	
SECTION DRAWINGS	

## TDe

ZAAGTABELLEN .....	121
COUPES ET DEBITS	
ZUSCHNITTSTABELLEN	
FABRICATION CHARTS	

## TDf

WERKTEKENINGEN .....	131
DESSINS DE CONSTRUCTION	
KONSTRUKTIONZEICHNUNGEN	
CONSTRUCTION DRAWINGS	

**aliplast**  
*member of*



**CORIALIS**

De tekeningen die voorgesteld zijn op schaal 1:1, kunnen kleine maatafwijkingen vertonen, te wijten aan de reproductietechniek van deze catalogoog.

Les dessins représentés à l'échelle 1 peuvent avoir de légères variations dimensionnelles dues aux techniques de reproduction de ce catalogue.





Die Zeichnungen im Maßstab 1:1 können aus technischen Reproduktionsgründen leichte Messung Schwankungen darstellen.



The drawings represented on a scale 1 basis may have light dimensional variations due to the reproduction of the manual.

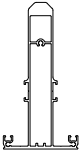
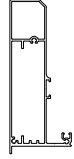
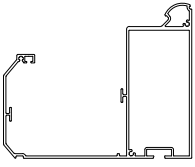

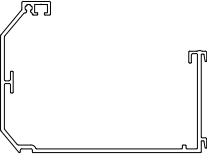



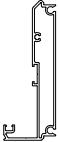

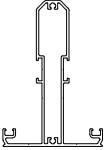
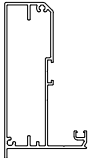
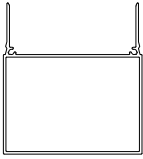
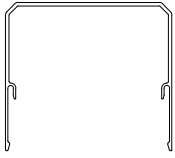
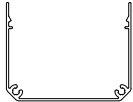
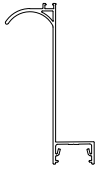
DATUM	PAGINA	OMSCHRIJVING
DATE	PAGE	DESCRIPTION
DATUM	SEITE	BESCHREIBUNG
DATE	PAGE	DESCRIPTION
28/01/2015	/	- EERSTE DRUK - PREMIERE EDITION - ERSTAUSGABE - FIRST EDITION
02/02/2015	152	- BEREKENING KIELGOOT TOEGEVOEGD - CALCULATION NOUVE AJOUTÉE - BERECHNUNG HOHLKEHLE HINZUGEFUGT - CALCULATION VALLEY ADDED
09/02/2015	83	- SILICONENDICHTING TOEGEVOEGD - ÉTANCHÉITÉ SILICON AJOUTÉE - SILIKONDICHTUNG HINZUGEFUGT - SILICON SEALING ADDED
17/02/2015	45	- STATICA Fmax. 8mm TOEGEVOEGD - STATIQUE Fmax. 8mm AJOUTÉE - STATIK Fmax. 8mm HINZUGEFUGT - STATICS Fmax. 8mm ADDED
03/02/2015	94	- SNEDES MET POLYCARBONAAT EN DUBBEL GLAS TOEGEVOEGD - SECTIONS AVEC POLYCARBONATE ET DOUBLE VITRAGE AJOUTÉES - SCHNITT MIT STEGPLATTEN UND ISOGLAS HINZUGEFUGT - SECTION WITH POLYCARBONATE AND DOUBLE GLAZING ADDED
16/06/2015	8	- VT062 IN PROFIELOVERZICHT TOEGEVOEGD - VT062 AJOUTÉES À LA LISTE PROFILS - VT062 HINZUGEFUGT IN PROFILLIST - VT062 ADDED IN PROFILELIST
23/06/2015	95	- BENAMING GL320 TOEGEVOEGD - NOM GL320 AJOUTÉES - NAME GL320 HINZUGEFUGT - NAME GL320 ADDED
07/08/2015	7	- TD565 TOEGEVOEGD - TD565 AJOUTÉES - TD565 HINZUGEFUGT - TD565 ADDED





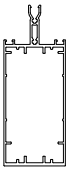

**WIJZIGINGEN - MODIFICATIONS - ÄNDERUNGEN - CHANGES**



NUMMER NUMERO NUMBER NUMBER	AFBEELDING IMAGE BILD PICTURE	OMSCHRIJVING DESCRIPTION BESCHREIBUNG DESCRIPTION	BLAD PAGE SEITE PAGE	OMTREK PERIM. PERIM. PERIM. (MM)	MECH. MEC. MECH. MEC. (MM)	IX (CM4) ----- WX (CM3)	IY (CM4) ----- WY (CM3)	LENGTE LONG. LANGE LENGTH (M)
<b>TD001</b>		AFWERKINGSPROFIEL PROFILE DE FINITION AUSFUEHRUNGSPROFIL FINISHING PROFILI  H = 9 MM	9	58.2	12.5	1 ----- 1	1 ----- 1	7
<b>TD011</b>		LIGGER CHEVRON DACHSPARREN RAFTER  H = 155 MM	12	608.1	299	424.15 ----- 52.65	32.72 ----- 8.28	7 4.3
<b>TD012</b>		ZIJLIGGER CHEVRON LATERAL RANDSPARREN SIDE RAFTER  H = 155 MM	13	509.2	370.4	296.9 ----- 32.66	37.43 ----- 8.98	7 4.3
<b>TD020</b>		GOOT GOUTTIERE RINNENPROFIL GUTTER  H = 164 MM	9	1120.9	633	638.46 ----- 65.44	1015.43 ----- 82.93	7 5.5
<b>TD021</b>		RINGBALK POUTRE D'ANNEAU UNTERZUG RINGBEAM  H = 188 MM	10	571.3	512.7	657.93 ----- 68.99	157.7 ----- 36.76	7 5.5
<b>TD022</b>		BEVESTIGINGSPROFIEL VOOR GOOT PROFIL DE MONTAGE POUR GOUTTIERE BEFESTIGUNGSPROFIL FÜR RINNE MOUNTING PROFILE FOR GUTTER  H = 75 MM	10	198.2	15.4	11.53 ----- 2.96	0.06 ----- 0.096	7
<b>TD023</b>		OPHANGGOOT GOUTTIERE RINNE GUTTER  H = 100 MM	10	753.1	253	101.37 ----- 15.33	253.35 ----- 33.09	7 5.5
<b>TD025</b>		MUURPROFIEL RACCORD MURAL WANDANSCHLUSS WALL SECTION  H = 100 MM	11	689.4	347.2	427.02 ----- 32.17	14.48 ----- 4.14	7 5.5

NUMMER NUMERO NUMBER NUMBER	AFBEELDING IMAGE BILD PICTURE	OMSCHRIJVING DESCRIPTION BESCHREIBUNG DESCRIPTION	BLAD PAGE SEITE PAGE	OMTREK PERIM. PERIM. PERIM. (MM)	MECH. MEC. MECH. MEC. (MM)	IX (CM4) ----- WX (CM3)	IY (CM4) ----- WY (CM3)	LENGTE LONG. LANGE LENGTH (M)
<b>TD030</b>		NOORDBOOM / KIELGOOT ARRETIER / NOUE GRATSPARREN / HOHLKEHLE HIP RAFTER / VALLEY  H = 129 MM	15	452.8	148.4	131.12 ----- 18.02	11.41 ----- 3.43	7
<b>TD032</b>		PROFIEL VOOR GLASDELING EMPANNON KOMPLETTSPROSSE SMALL RAFTER  H = 13 MM	21	219.7	75.1	0.29 ----- 0.32	6.95 ----- 2.25	7
<b>TD111</b>		LIGGER CHEVRON DACHSPARREN RAFTER  H = 116 MM	12	531	222.2	130.3 ----- 18.05	24.75 ----- 6.26	7 4.3
<b>TD112</b>		ZIJLIGGER CHEVRON LATERAL RANDSPARREN SIDE RAFTER  H = 112 MM	13	447.4	227.2	145.37 ----- 21.87	28.29 ----- 6.8	7 4.3
<b>TD171</b>		STEUNPAAL PROFILE DE SUPPORT STÜTZENPROFIL SUPPORTING PROFILE  H = 79 MM	17	554.7	268.1	180.44 ----- 32.8	131.63 ----- 19.08	5.5
<b>TD172</b>		AFDEKPROFIEL STEUNPAAL PROFILE DE RECOUVREMENT STÜTZENVERKLEIDUNG COVERING PROFILE  H = 98 MM	17	637.3	297.8	140.47 ----- 25.54	61.3 ----- 9.12	5.5
<b>TD211</b>		KABELGOOT LIGGER PROFILE DE RECOUVREMENT KABELKANAL WIREWAY PROFILE RAFTER  H = 65 MM	16	456.2	204.2	16.02 ----- 3.57	44.42 ----- 10.78	7
<b>TD217</b>		SCHARNIERPROFIEL PROFILE PIVOTANT SCHWENKPROFIL RAFTER HOLDER  H = 127 MM	19	466.4	313.5	106.66 ----- 15.98	15.98 ----- 3.1	7

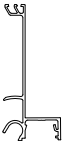
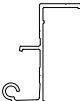
NUMMER NUMERO NUMBER NUMBER	AFBEELDING IMAGE BILD PICTURE	OMSCHRIJVING DESCRIPTION BESCHREIBUNG DESCRIPTION	BLAD PAGE SEITE PAGE	OMTREK PERIM. PERIM. PERIM. (MM)	MECH. MEC. MECH. MEC. (MM)	IX (CM4) ----- WX (CM3)	IY (CM4) ----- WY (CM3)	LENGTE LONG. LANGE LENGTH (M)
<b>TD225</b>		KABELGOOT MUURPROFIEL PROFILE DE RECOUVREMENT KABELKANAL WANDANSCHLUSS WIREWAY PROFILE WALL PROFILE  H = 65 MM	16	370.6	161.4	11.53 ----- 2.97	13.35 ----- 5.38	7
<b>TD565</b>		VERHOOGPROFIEL PROFILE DE REHAUSSEMENT ERHOHUNGSPROFIL RAISE PROFILE  H = 20 MM	18	370.6	161.4	11.53 ----- 2.97	13.35 ----- 5.38	7
<b>GL030TD</b>		GLASLAT PARCLOSE GLASLEISTE GLAZING BEAD  B = 30 MM	23	180.4	49.5	/ ----- /	/ ----- /	7 4.3
<b>GL041TD</b>		GLASLAT PARCLOSE GLASLEISTE GLAZING BEAD  B = 41 MM	23	202.4	60.5	/ ----- /	/ ----- /	7 4.3
<b>ER011</b>		LIGGER CHEVRON DACHSPARREN RAFTER  H = 116 MM	14	485.5	291	236.3 ----- 29.2	43.1 ----- 15.1	7 4.0 3.0
<b>ER030</b>		AFDEKPROFIEL PROFILE DE RECOUVREMENT ABDECKPROFIL COVERING PROFILE  H = 25 MM	22	357	105	8.8 ----- 3.1	2.2 ----- 1.1	7 4.0 3.0
<b>VR190</b>		AFSLUITPROFIEL PROFILE DE FERMETURE VENTIL PROFIL CLOSING PROFILE  H = 16 MM	19	150.4	84	/ ----- /	/ ----- /	7
<b>VR224</b>		VERHOOGPROFIEL PROFILE DE REHAUSSE ERHOHUNG RINNE RAISING PROFILE  H = 40 MM	18	207.2	66.2	/ ----- /	/ ----- /	7

NUMMER NUMERO NUMBER NUMBER	AFBEELDING IMAGE BILD PICTURE	OMSCHRIJVING DESCRIPTION BESCHREIBUNG DESCRIPTION	BLAD PAGE SEITE PAGE	OMTREK PERIM. PERIM. PERIM. (MM)	MECH. MEC. MECH. MEC. (MM)	IX (CM4) ----- WX (CM3)	IY (CM4) ----- WY (CM3)	LENGTE LONG. LANGE LENGTH (M)
VR6031		KOPPELPROFIEL PROFILE DE COUPLAGE KUPPLUNG PROFIL COUPLING PROFILE	15	50.8	/	/	/	7
MC055		KLEMPROFIEL VOOR GLASDELING PROFILE DE SERRAGE DRUCKLEISTE FÜR GLASTEILUNG SUB-PROFIELE H = 4.5 MM	21	129.1	59	/	/	7
SR014		AFWERKINGSPROFIEL PROFILE DE FINITION AUSFUEHRUNGSPROFIL FINISHING PROFILE H = 14.5 MM	22	110.4	28.5	/	/	7 3.5
UN001		AFWERKINGSPROFIEL PROFILE DE FINITION AUSFUEHRUNGSPROFIL FINISHING PROFILE H = 4.5 MM	22	44	16.5	/	/	7
VR017N		SCHARNIERPROFIEL PROFILE PIVOTANT SCHWENKPROFIL RAFTER HOLDER H = 108 MM	20	451.5	137.7	51.47	7.66	7
VR070N		BASISPROFIEL VOOR SCHARNIER PROFILE DE BASE POUR CHARNIERE BASISPROFIL FÜR SCHARNIERPROFIL BASE PROFILE FOR HINGE H = 66 MM	20	300.9	53	/	/	7
VT062		VERHOOGPROFIEL PROFILE DE REHAUSSEMENT ERHOHUNGSPROFIL RAISE PROFILE H = 10 MM	18	76.9	26	/	/	6.5



GOOT  
GOUTTIERE  
RINNE  
GUTTER

PROFIELEN - PROFILS-PROFILE - PROFILES

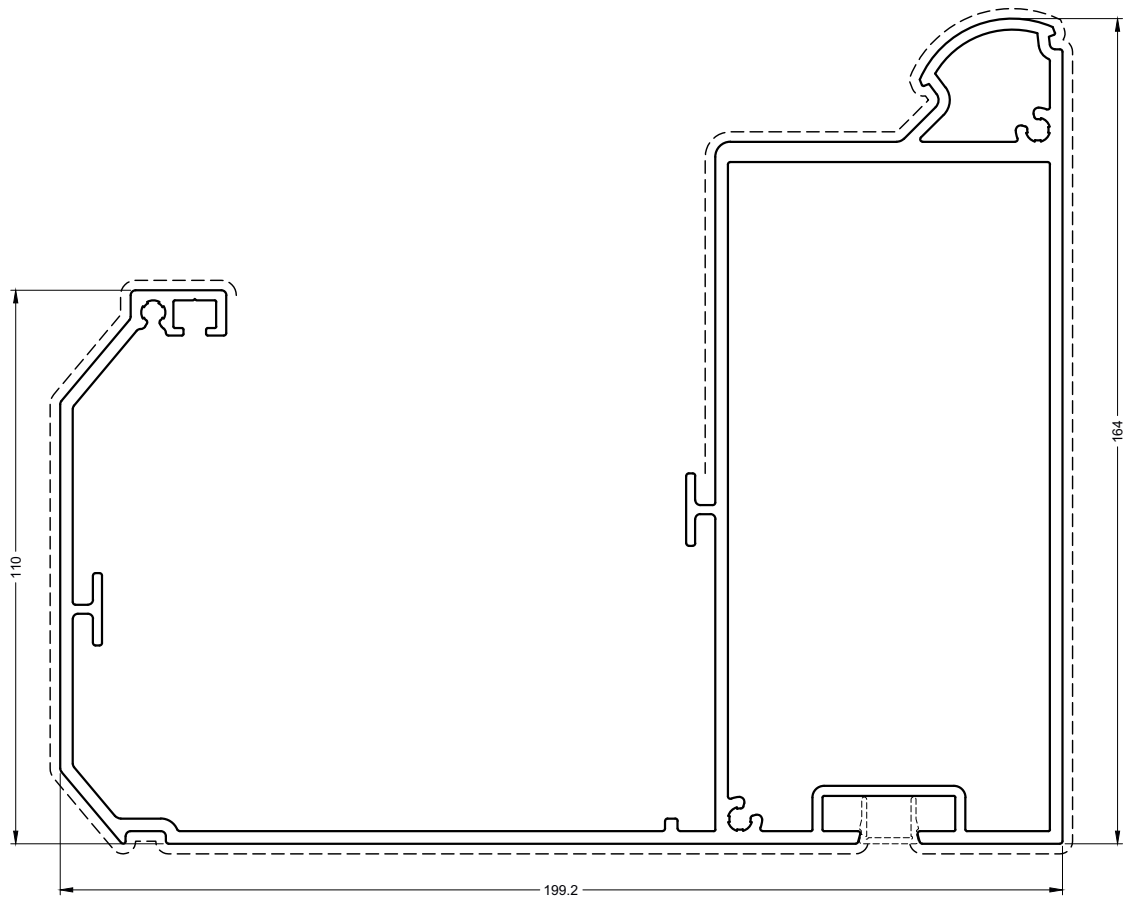

TD020

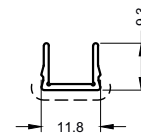

TD001



TD020-TD001

**aliplast**  
member of

**CORIALIS**

-----  
Primaire zichtbare zijde  
Face visible primaire

-----  
Primär sichtbare Seite  
Primary visible side

7/8/15

# TD Terrassendach

RNGBALK MET GOOT  
 SABLIERE AVEC GOUTTIERE  
 UNTERZUG MIT RINNE  
 RINGBEAM WITH GUTTER

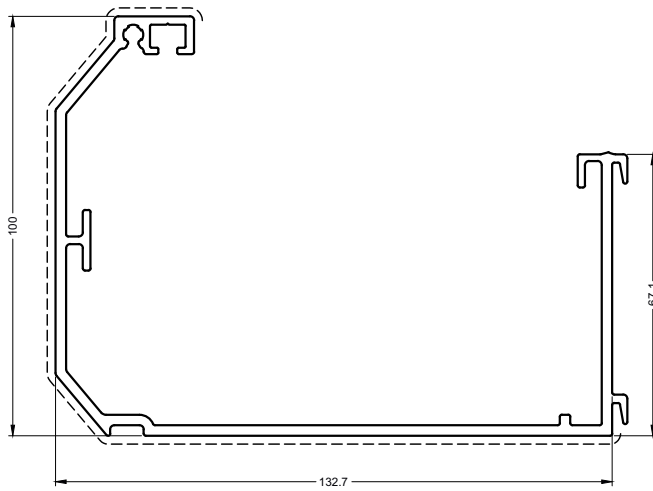

TD023



TD022

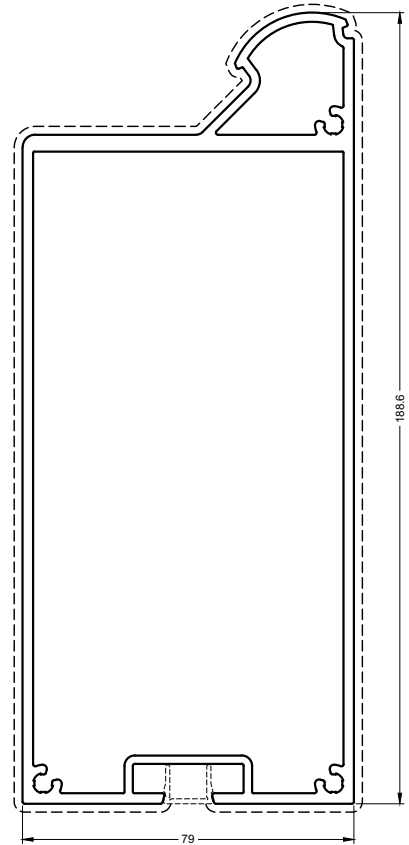

TD021

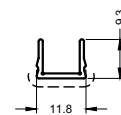

TD001

TD021-TD022-TD023

----- Primaire zichtbare zijde  
 Face visible primaire



Primär sichtbare Seite  
 Primary visible side

MUURPROFIEL  
RACCORD MURAL  
WANDANSCHLUSS  
WALL SECTION

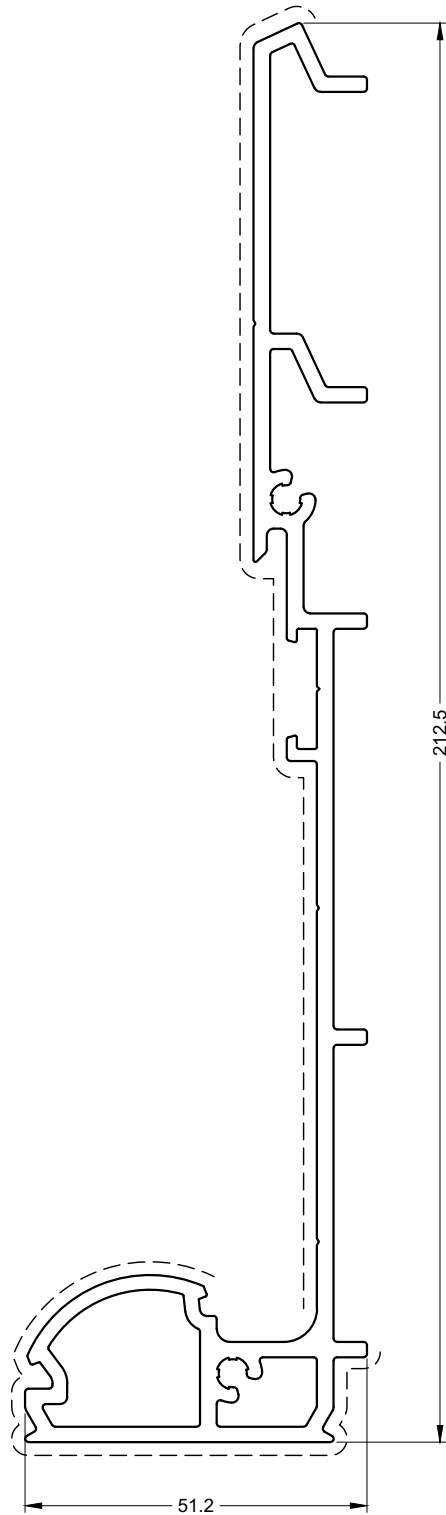

**PROFIELEN - PROFILS-PROFILE - PROFILES**



**TD025**

TD025

**aliplast**  
member of



Primaire zichtbare zijde  
Face visible primaire

Primär sichtbare Seite  
Primary visible side

7/8/15

# TD Terrassendach

LIGGERS  
CHEVRONS  
DACHSPARREN  
RAFTERS

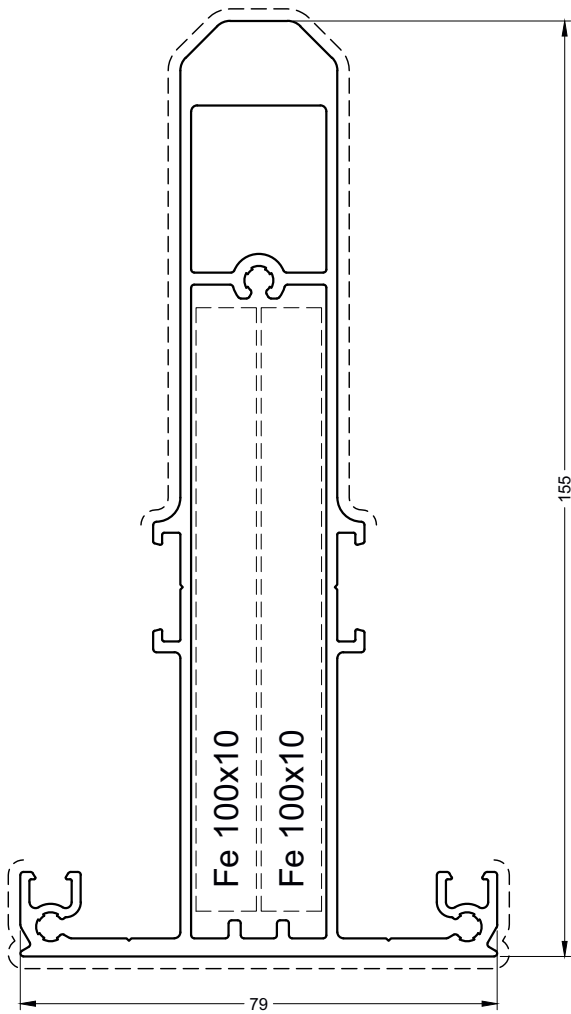

TD011

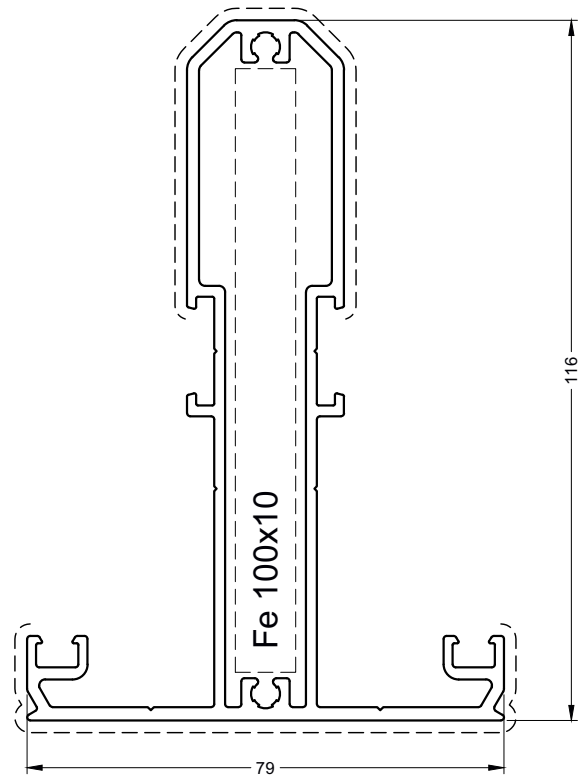

TD111

TD011-TD111



12



Primaire zichtbare zijde  
Face visible primaire

Primär sichtbare Seite  
Primary visible side

7/8/15

ZIJLIGGERS  
CHEVRON LATERAL  
RANDSPARREN  
SIDE RAFTERS

PROFIELEN - PROFILS-PROFILE - PROFILES

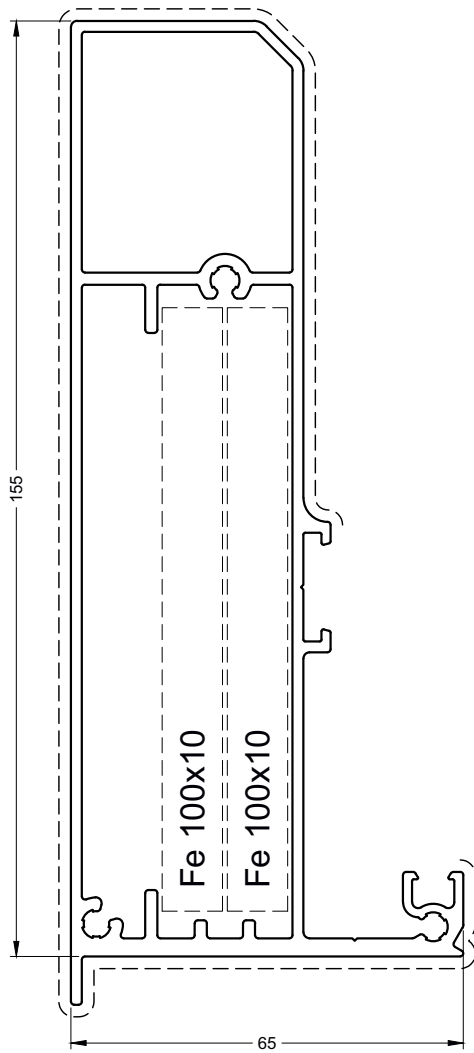

TD012

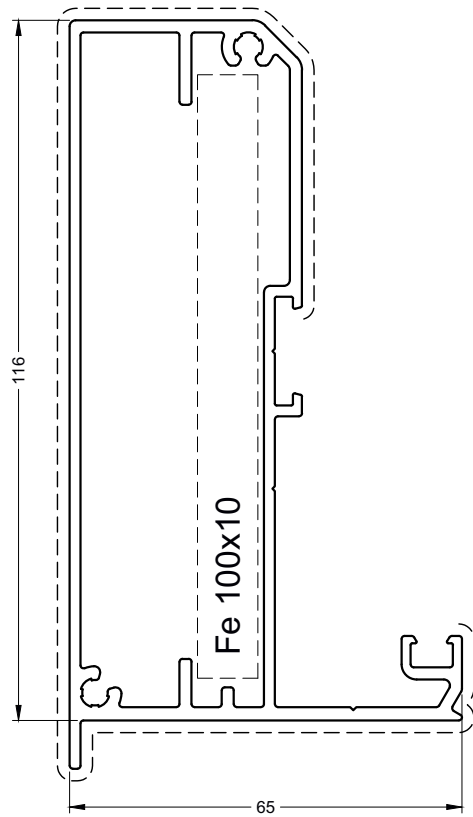

TD112

TD012-TD112

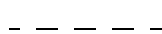

Primaire zichtbare zijde  
Face visible primaire

Primär sichtbare Seite  
Primary visible side



7/8/15

# TD Terrassendach

LIGGERS  
CHEVRONS  
DACHSPARREN  
RAFTERS

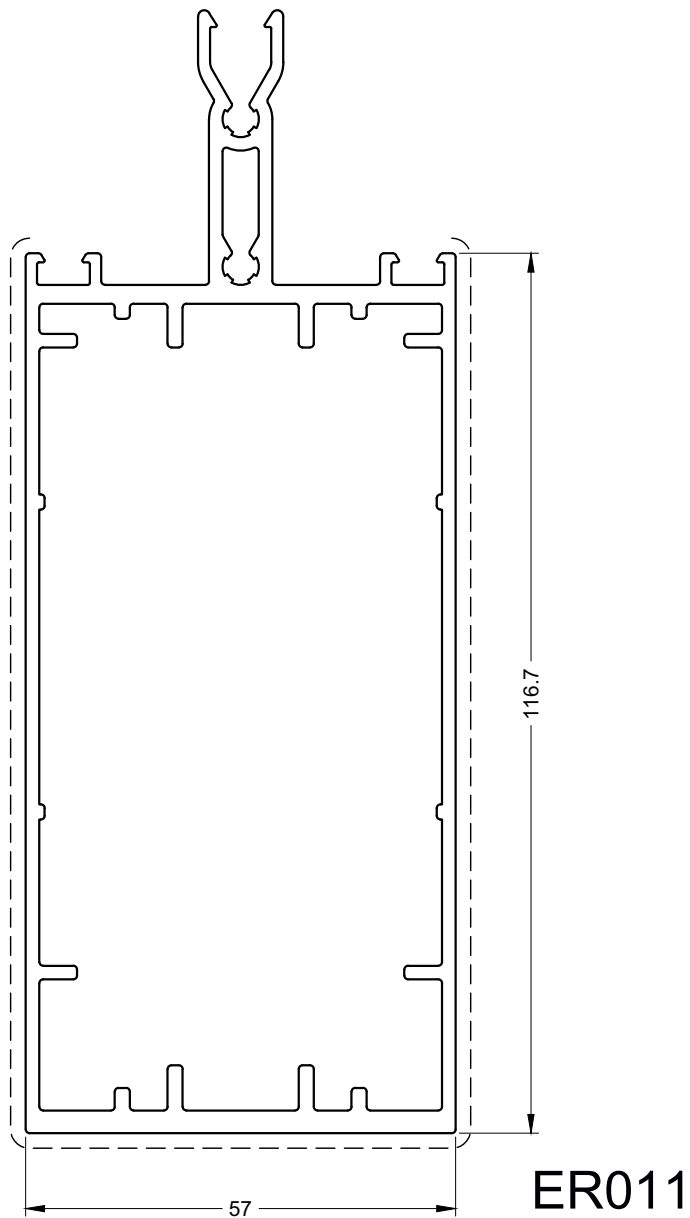

ER011

14



Primaire zichtbare zijde  
Face visible primaire

Primär sichtbare Seite  
Primary visible side

7/8/15

NOORDBOOM / KIELGOOT  
 ARRETIER / NOUE  
 GRATSPARREN / HOHLKEHLE  
 HIP RAFTER / VALLEY

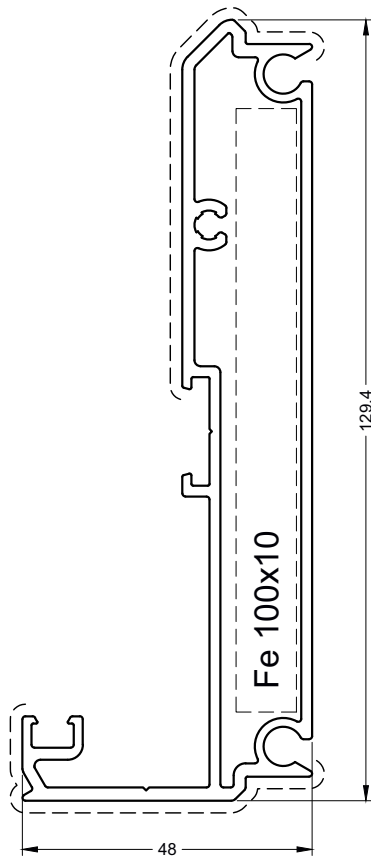

**TD030**

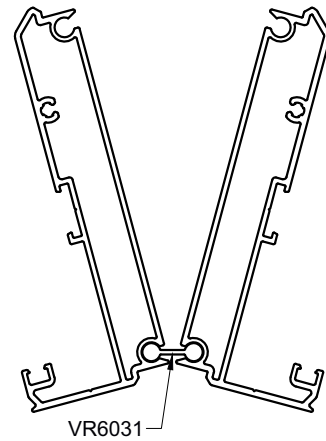
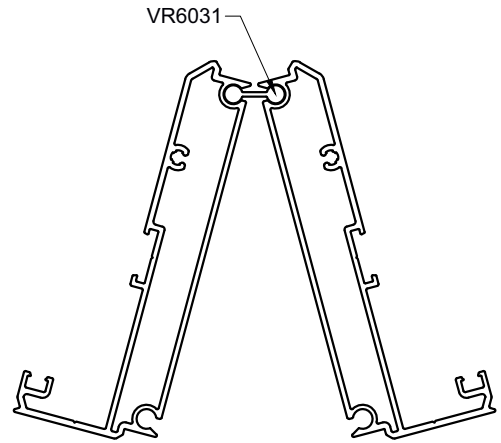

**PROFIELEN - PROFILS-PROFILE - PROFILES**

TD030



Primaire zichtbare zijde  
 Face visible primaire

Primär sichtbare Seite  
 Primary visible side

7/8/15

# TD Terrassendach

KABELGOTEN  
 PROFILE DE RECOUVREMENT  
 KABELKANALS  
 WIREWAY PROFILES

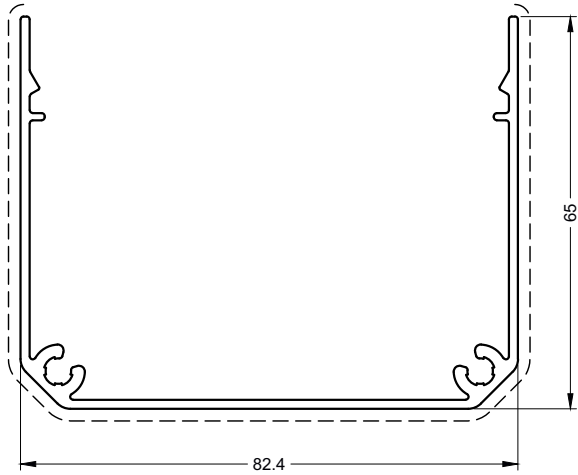

TD211

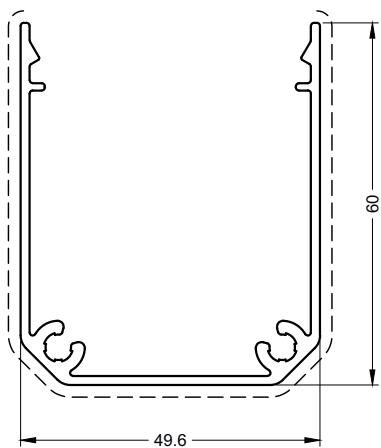
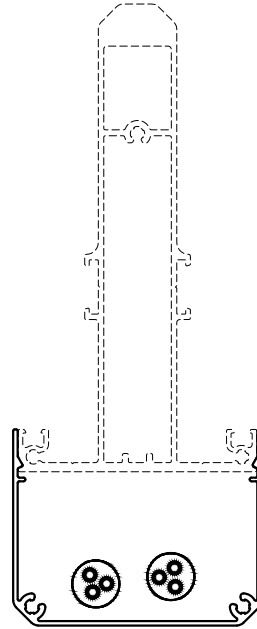

TD225

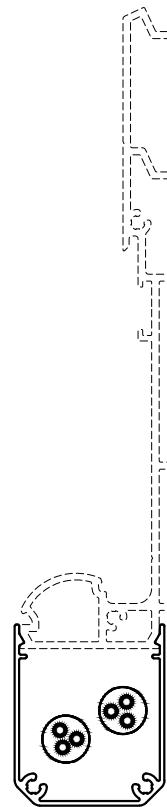

TD211-TD225

----- Primaire zichtbare zijde  
 Face visible primaire

----- Primär sichtbare Seite  
 Primary visible side



STEUNPAAL EN AFDEKPROFIEL  
 PROFILE DE SUPPORT ET CAPOT  
 STÜTZENPROFIL UND STÜTZENVERKLEIDUNG  
 SUPPORTING PROFILE AND COVER

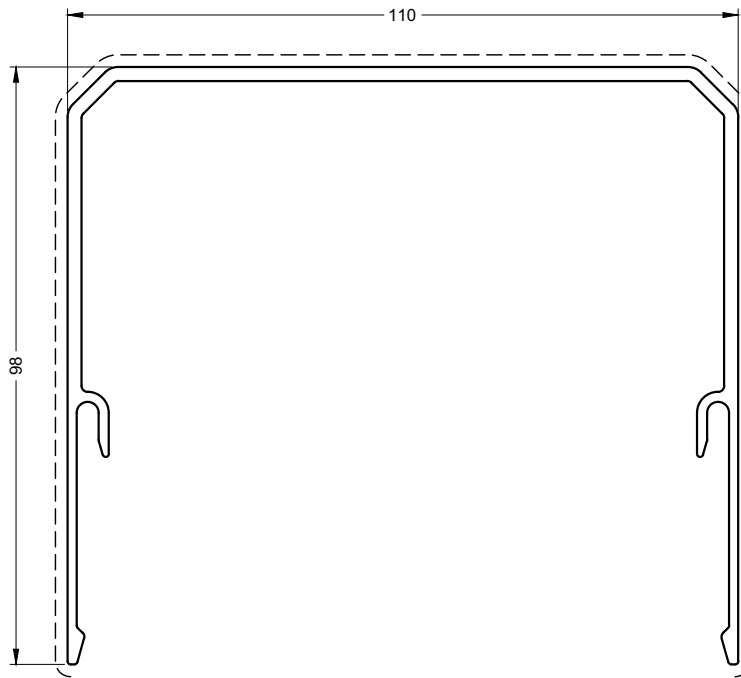

TD172

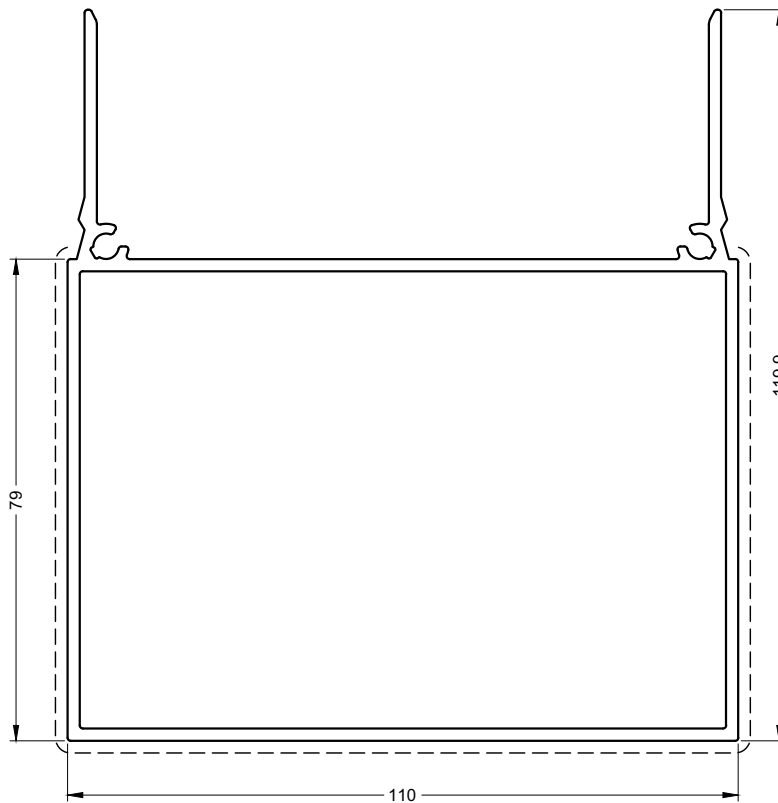

TD171



PROFIELEN - PROFILS-PROFILE - PROFILES

TD171-TD172

**aliplast**  
 member of



-----  
 Primaire zichtbare zijde  
 Face visible primaire

Primär sichtbare Seite  
 Primary visible side

7/8/15

# TD Terrassendach

VERHOGINGSPROFIEL  
 PROFILE REHAUSSEMENT  
 ERHÖHUNG PROFIL  
 RAISING PROFILE

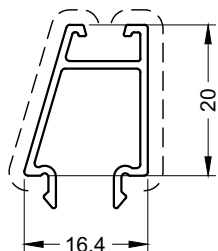

**TD565**

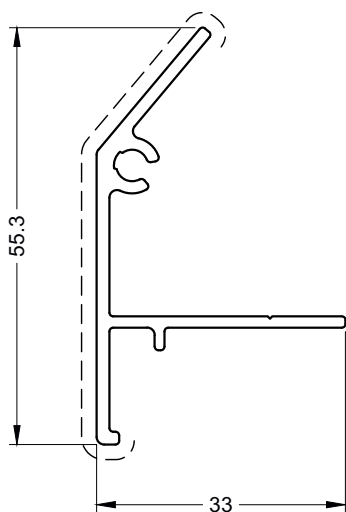
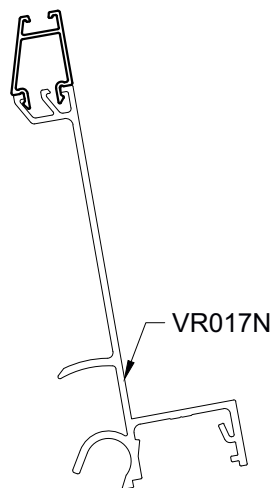

**VR224**

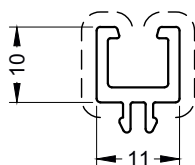
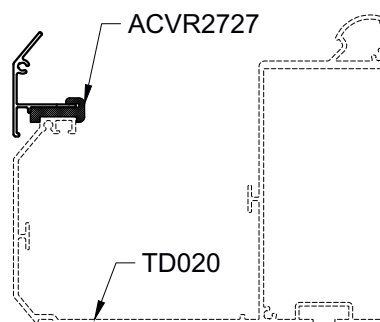

**VT062**

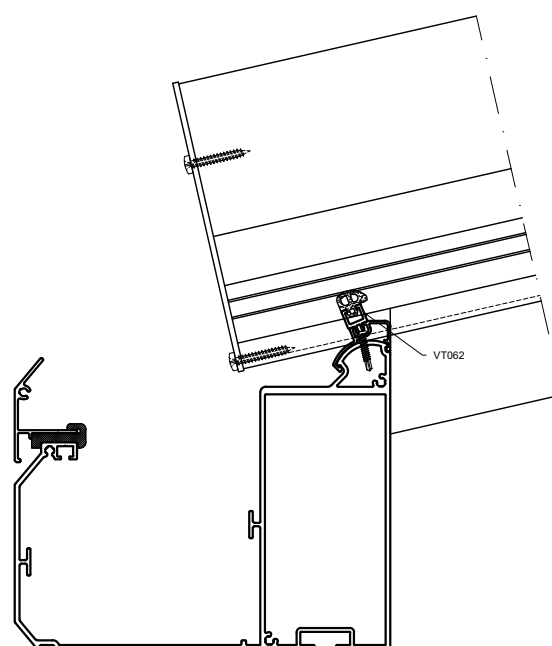

TD565-VR224-VT062

SCHARNIERPROFIEL  
PROFIL PIVOTANT  
SCHWENKPROFIL  
RAFTER HOLDER

PROFIELEN - PROFILS-PROFILE - PROFILES

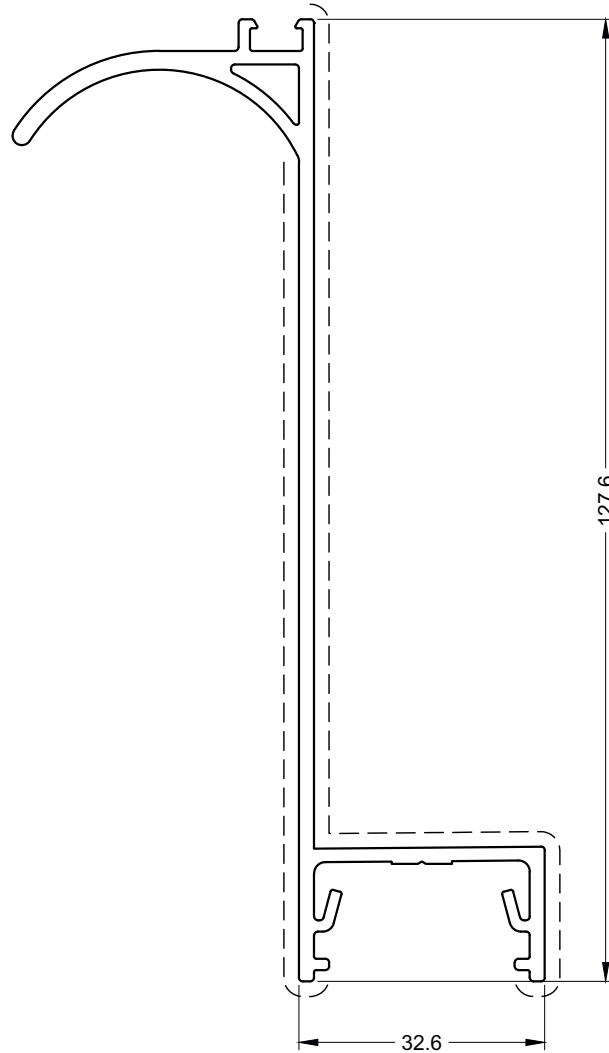

**TD217**

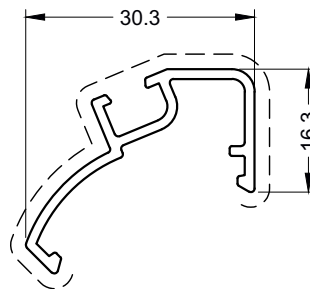

**VR190**

TD217-VR190

**aliplast**  
member of



Primaire zichtbare zijde  
Face visible primaire

Primär sichtbare Seite  
Primary visible side

7/8/15

# TD Terrassendach

SCHARNIERPROFIEL  
PROFIL PIVOTANT  
SCHWENKPROFIL  
RAFTER HOLDER

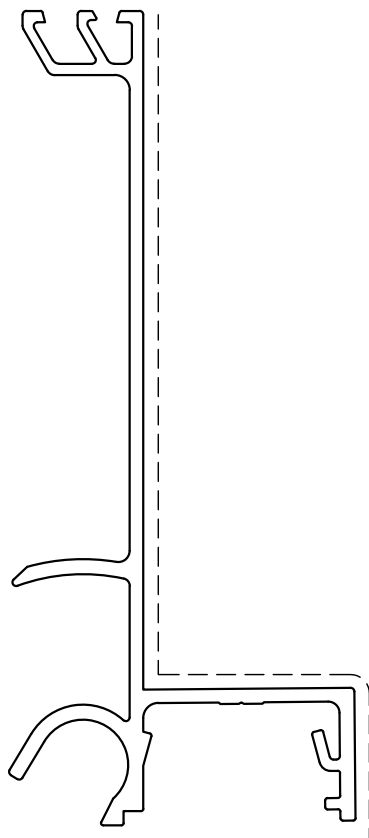

**VR017N**

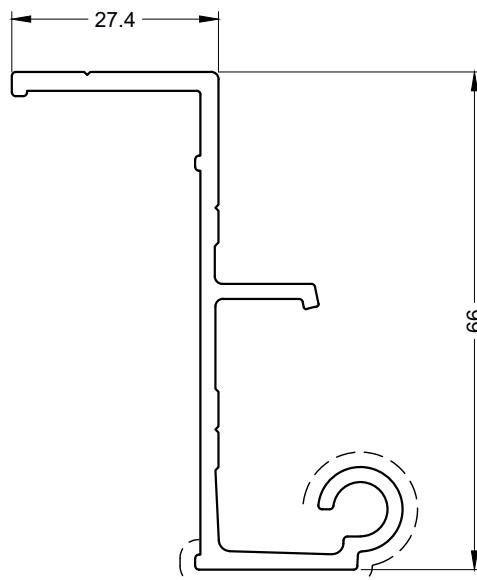

**VR070N**

VR017N-VR070N

**20**



Primaire zichtbare zijde  
Face visible primaire

Primär sichtbare Seite  
Primary visible side

7/8/15

DWARSPROFIEL  
TRAVERSE  
RIEGELPROFIL  
TRANSOM

PROFIELEN - PROFILS-PROFILE - PROFILES

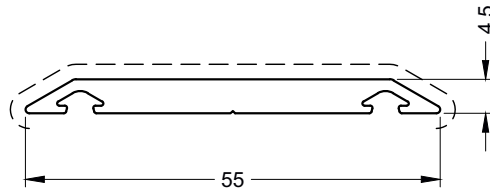

## MC055

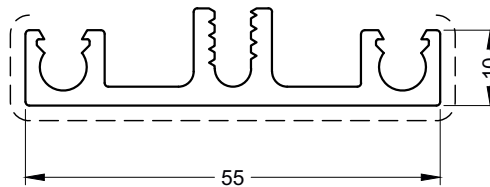

## TD032

TD032-MC055

**aliplast**  
member of



Primaire zichtbare zijde  
Face visible primaire

Primär sichtbare Seite  
Primary visible side

7/8/15

AFDEKPROFIEL  
 PROFILE DE RECOUVREMENT  
 ABDECKPROFIL  
 COVERING PROFILE

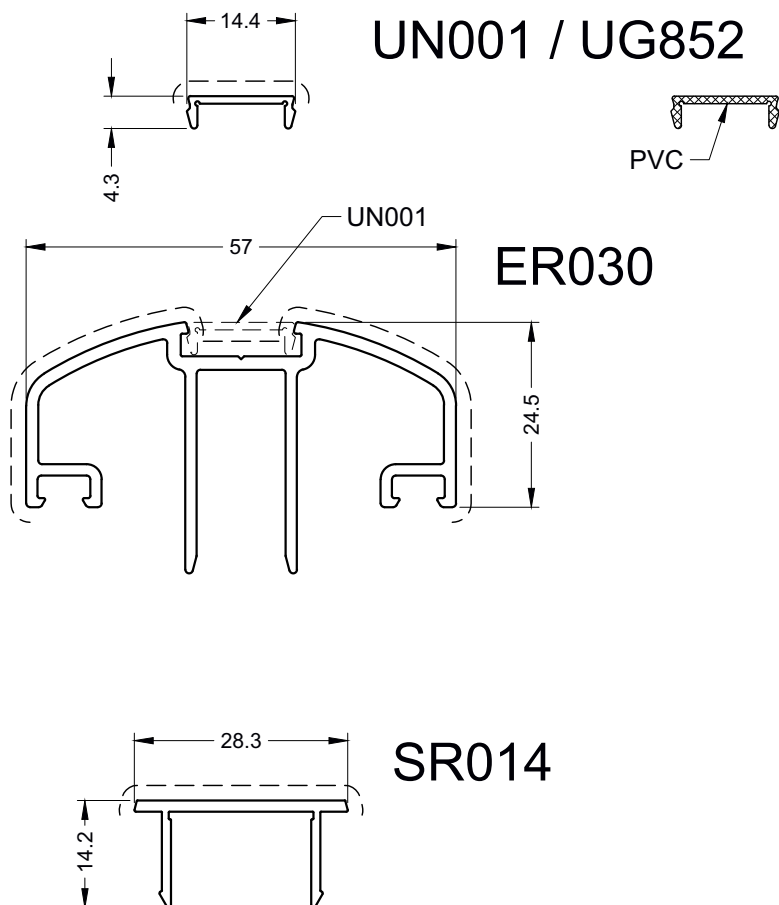

ER030-UN001-SR014



Primaire zichtbare zijde  
 Face visible primaire

Primär sichtbare Seite  
 Primary visible side

GLASLATTEN  
PARCLOSES  
GLASLEISTE  
GLAZING BEADS

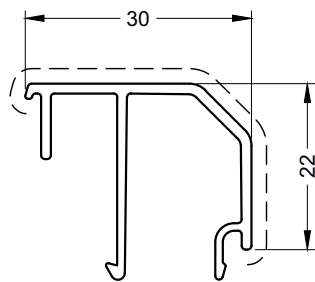

**GL030TD**

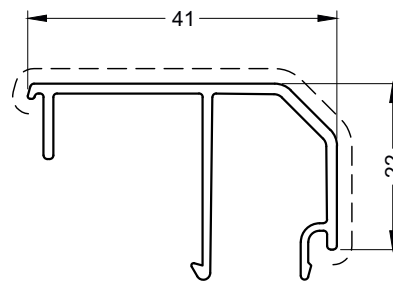

**GL041TD**

**PROFIELEN - PROFILS-PROFILE - PROFILES**

GL030TD-GL041TD

**aliplast**  
member of





Primaire zichtbare zijde  
Face visible primaire

Primär sichtbare Seite  
Primary visible side

7/8/15



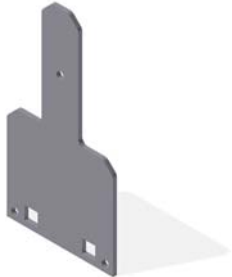

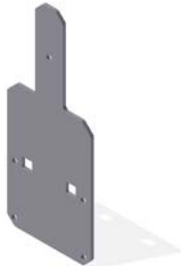
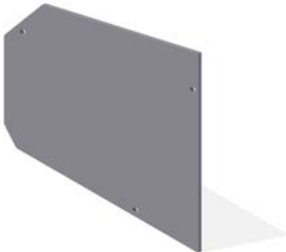
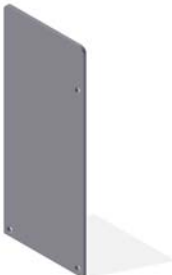



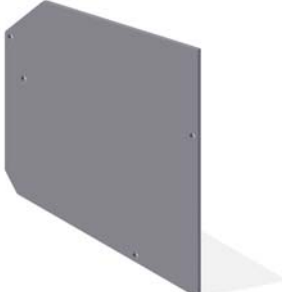
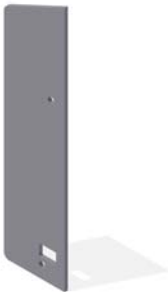

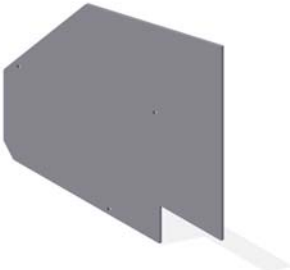
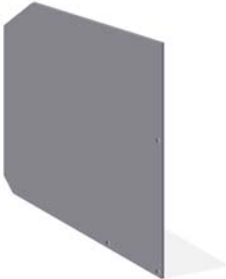
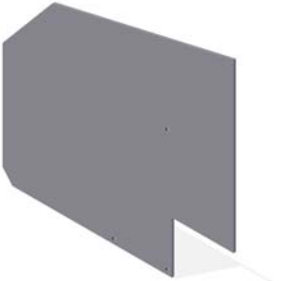
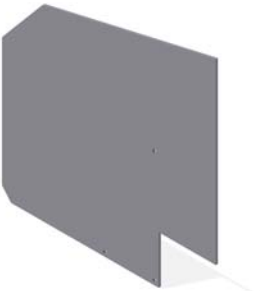

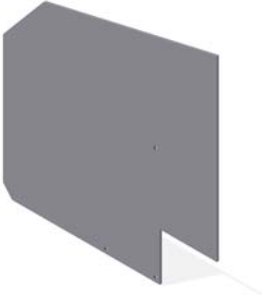
AFBEELDING IMAGE BILD PICTURE	OMSCHRIJVING DESCRIPTION BESCHREIBUNG DESCRIPTION	TOEPASSING APPLICATION ANWENDUNG APPLICATION	VERP.PER EMB.PAR PACK PR. PACK PR.
	<p><b>ACTD011</b></p> <p>EINDPLAAT PLAQUE ENDSTÜCK ENDPIECE</p>	TD011	1
	<p><b>ACTD012</b></p> <p>EINDPLAAT PLAQUE ENDSTÜCK ENDPIECE</p>	TD012	1
	<p><b>ACTD015</b></p> <p>EINDPLAAT PLAQUE ENDSTÜCK ENDPIECE</p>	TD011 + TD211	1
	<p><b>ACTD020</b></p> <p>EINDPLAAT PLAQUE ENDSTÜCK ENDPIECE</p>	TD020	1
	<p><b>ACTD021</b></p> <p>EINDPLAAT PLAQUE ENDSTÜCK ENDPIECE</p>	TD021	1

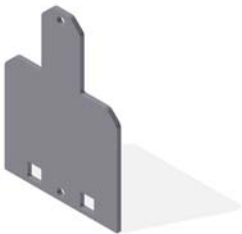

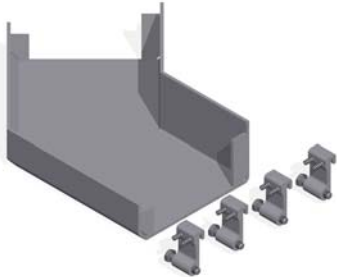

**TOEBEHOREN - ACCESSOIRES - ZUBEHÖRTEILE - ACCESSORIES**

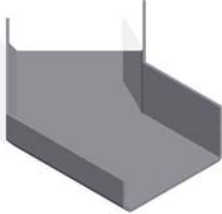
AFBEELDING IMAGE BILD PICTURE	OMSCHRIJVING DESCRIPTION BESCHREIBUNG DESCRIPTION	TOEPASSING APLPLICATION ANWENDUNG APPLICATION	VERP.PER EMB.PAR PACK PR. PACK PR.
	<p><b>ACTD022</b></p> <p>EINDPLAAT PLAQUE ENDSTÜCK ENDPIECE</p>	<p>TD021 + TD022 + TD023</p>	<p>1</p>
	<p><b>ACTD023</b></p> <p>EINDPLAAT PLAQUE ENDSTÜCK ENDPIECE</p>	<p>TD020 + VR224 + TD217</p>	<p>1</p>
	<p><b>ACTD024</b></p> <p>EINDPLAAT PLAQUE ENDSTÜCK ENDPIECE</p>	<p>TD020 + VR224</p>	<p>1</p>
	<p><b>ACTD025</b></p> <p>EINDPLAAT PLAQUE ENDSTÜCK ENDPIECE</p>	<p>TD025</p>	<p>1</p>
	<p><b>ACTD026</b></p> <p>EINDPLAAT PLAQUE ENDSTÜCK ENDPIECE</p>	<p>TD025 + TD225</p>	<p>1</p>





AFBEELDING IMAGE BILD PICTURE	OMSCHRIJVING DESCRIPTION BESCHREIBUNG DESCRIPTION	TOEPASSING APLPLICATION ANWENDUNG APPLICATION	VERP.PER EMB.PAR PACK PR. PACK PR.
	<b>ACTD027</b>  EINDPLAAT PLAQUE ENDSTÜCK ENDPIECE	TD025 + TD217	1
	<b>ACTD040</b>  EINDPLAAT PLAQUE ENDSTÜCK ENDPIECE	TD020 + TD217	1
	<b>ACTD041</b>  EINDPLAAT PLAQUE ENDSTÜCK ENDPIECE	TD021 + TD022 + TD023 + VR224	1
	<b>ACTD042</b>  EINDPLAAT PLAQUE ENDSTÜCK ENDPIECE	TD021 + TD022 + TD023 + TD217	1
	<b>ACTD043</b>  EINDPLAAT PLAQUE ENDSTÜCK ENDPIECE	TD021 + TD022 + TD023 + VR224 + TD217	1





AFBEELDING IMAGE BILD PICTURE	OMSCHRIJVING DESCRIPTION BESCHREIBUNG DESCRIPTION	TOEPASSING APLPLICATION ANWENDUNG APPLICATION	VERP.PER EMB.PAR PACK PR. PACK PR.
	<p><b>ACTD044</b></p> <p>EINDPLAAT PLAQUE ENDSTÜCK ENDPIECE</p>	<p>TD021 + TD022 + TD023 + VR224 + TD565</p>	<p>1</p>
	<p><b>ACTD100</b></p> <p>BGLAZINGSRUBBER LIGGER JIONT DE VITRAGE CHEVRON VERGLASUNGSDICHTUNG SPARREN GLAZING GASKET RAFTER</p>	<p>TD011 TD111</p>	<p>50M</p>
	<p><b>ACTD105</b></p> <p>BGLAZINGSRUBBER LIGGER JIONT DE VITRAGE CHEVRON VERGLASUNGSDICHTUNG SPARREN GLAZING GASKET RAFTER</p>	<p>TD011 TD111</p>	<p>25M</p>
	<p><b>ACTD111</b></p> <p>EINDPLAAT PLAQUE ENDSTÜCK ENDPIECE</p>	<p>TD111</p>	<p>1</p>
	<p><b>ACTD112</b></p> <p>EINDPLAAT PLAQUE ENDSTÜCK ENDPIECE</p>	<p>TD112</p>	<p>1</p>

AFBEELDING IMAGE BILD PICTURE	OMSCHRIJVING DESCRIPTION BESCHREIBUNG DESCRIPTION	TOEPASSING APPLICATION ANWENDUNG APPLICATION	VERP.PER EMB.PAR PACK PR. PACK PR.
	<p><b>ACTD115</b></p> <p>EINDPLAAT PLAQUE ENDSTÜCK ENDPIECE</p>	<p>TD111 + TD211</p>	<p>1</p>
	<p><b>ACTD120</b></p> <p>AANTREKSTUK PIECE DE SERRAGE RINNENSANNER CLAMPING PIECE</p> <p> on page 41</p>	<p>TD020 TD023</p>	<p>1</p>
	<p><b>ACTD121</b></p> <p>AANTREKSTUK PIECE DE SERRAGE RINNENSANNER CLAMPING PIECE</p> <p>4000mm</p>	<p>TD020 TD023 ACTD120 ACTD121</p>	<p>1</p>
	<p><b>ACTD122</b></p> <p>GELAST HOEKSTUK PIECE SOUDÉ GESCHWEIST STÜCK WELDED PIECE</p> <p> on page 42</p>	<p>TD020 TD023</p>	<p>1</p>
	<p><b>ACTD123</b></p> <p>AANTREKSTUKJE PIECE DE SERRAGE KLEMTEIL CLAMPING PIECE</p>	<p>ACTD122</p>	<p>1</p>

AFBEELDING IMAGE BILD PICTURE	OMSCHRIJVING DESCRIPTION BESCHREIBUNG DESCRIPTION	TOEPASSING APLPLICATION ANWENDUNG APPLICATION	VERP.PER EMB.PAR PACK PR. PACK PR.
	<p><b>ACTD124</b></p> <p>TEGENPLAATJES CONTRE PLAQUES PLATE COUNTER PLATES</p>	ACTD122	1
	<p><b>ACTD125</b></p> <p>VARIABLE VERBINDING RACCORD ORIENTABLE VERSTELBARE VERBINDUNG ADJUSTABLE CONNECTION</p>	TD020 TD023	1
	<p><b>ACTD130</b></p> <p>AFSTANDSHOUDER GLAS PIÈCE DE CALAG AUSGLEICHSTÜCK GLAS SPACE PIECE GLAS</p>	TD011 TD111	1
	<p><b>ACTD135</b></p> <p>AFSTANDSHOUDER GLAS PIÈCE DE CALAG AUSGLEICHSTÜCK GLAS SPACE PIECE GLAS</p>	TD011 TD111	1
	<p><b>ACTD220</b></p> <p>VERBINDINGSTUK GOOT - PAAL PIECE DE CONNECTION GOUTTIERE - POTEAU VERBINDUNGSTÜCK RINNE - STÜTZEN CONNEXION PIECE GUTTER - SUPPORT PROFILE</p>	TD020 TD171	1

ALU

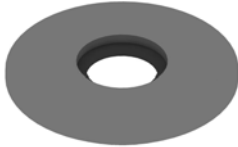
AFBEELDING IMAGE BILD PICTURE	OMSCHRIJVING DESCRIPTION BESCHREIBUNG DESCRIPTION	TOEPASSING APLPLICATION ANWENDUNG APPLICATION	VERP.PER EMB.PAR PACK PR. PACK PR.
	<b>ACDR050</b> DIN7981 4.8 X 32		200
	<b>ACDR052</b> DIN7981 4.8 X 50		200
	<b>ACER130</b> EINDPLAAT PLAQUE ENDSTÜCK ENDPIECE	ER011	1
	<b>ACMC015</b> BEGLAZINGSRUBBER JOINT DE VITRAGE VERGLASUNGSDICHTUNG SEALING  13 MM	TD011 TD111	100
	<b>ACMC016</b> BEGLAZINGSRUBBER JOINT DE VITRAGE VERGLASUNGSDICHTUNG SEALING  3 MM	TD011 TD111	150

AFBEELDING IMAGE BILD PICTURE	OMSCHRIJVING DESCRIPTION BESCHREIBUNG DESCRIPTION	TOEPASSING APLPLICATION ANWENDUNG APPLICATION	VERP.PER EMB.PAR PACK PR. PACK PR.
	<p><b>ACMC025</b></p> <p>PEN VOOR REGEN TIGE POUR TRAVERSE STIFT FÜR RIEGEL PIN FOR TRANSOM</p>	TD032	1
	<p><b>ACMC026</b></p> <p>PEN VOOR EINDREGEL TIGE POUR DERNIÈRE TRAVERSE STIFT FÜR ENDRIEGEL PIN FOR ENDING TRANSOM</p>	TD032	1
	<p><b>ACMC111</b></p> <p>AFDICHTINGSRING RNDELLE D'ÉTANCHÉITÉ DICHTSCHEIBE SEALING RING</p>	TD011 TD111 MC055	100
	<p><b>ACMC117</b></p> <p>BEGLAZINGSRUBBER JOINT DE VITRAGE VERGLASUNGSDICHTUNG SEALING</p>	MC055	100
	<p><b>ACMX09700</b></p> <p>ALU-POLISH</p> <p>OPGEPAST VOOR NATUURSTEEN EN METSELWERK ATTENTION POUR PIERRE DE TAILLE ET MAÇONNERIE ACHTUNG FÜR NATURSTEIN UND MAUERWERK ATTENTION FOR NATURAL STONE AND BRICKLAYING</p>		1



AFBEELDING IMAGE BILD PICTURE	OMSCHRIJVING DESCRIPTION BESCHREIBUNG DESCRIPTION	TOEPASSING APPLICATION ANWENDUNG APPLICATION	VERP.PER EMB.PAR PACK PR. PACK PR.
	<p><b>ACMX09761</b> MAXI-GLOSS</p>		1
	<p><b>ACMX09762</b> PERIODI-CLEAN</p>		1
	<p><b>ACMX09763</b> TEFLON SPRAY</p>		1
	<p><b>ACMX09764</b> MAXI-CLEANER</p>		1
	<p><b>ACMX09765</b> GLUE-CLEANER KUISMIDDEL VOOR LIJM NETTOYANT POUR COLLE REINIGUNGSMITTEL FÜR KLEBER CLEANER FOR GLUE</p>		1

AFBEELDING IMAGE BILD PICTURE	OMSCHRIJVING DESCRIPTION BESCHREIBUNG DESCRIPTION	TOEPASSING APLPLICATION ANWENDUNG APPLICATION	VERP.PER EMB.PAR PACK PR. PACK PR.
	<p><b>ACMX09766</b> SURFACE ACTIVATOR</p>		1
	<p><b>ACMX09770</b> ROL ANDYWRAP 100MM ROULEAU ANDYWRAP 100MM ROLLE ANDYWRAP 100MM ROLL ANDYWRAP 100MM</p>		1
	<p><b>ACMX09775</b> HOUDER ANDYWRAP MANCHE ANDYWRAP HALTER ANDYWRAP GRIP ANDYWRAP</p>		1
	<p><b>ACMX09801</b> BESCHERMTAPE 50MM (500M) TAPE DE PROTECTION 50MM (500M) SCHUTZ KLEBEBAND 50MM (500M) PROTECTIVE TAPE 50MM (500M)</p>		1
	<p><b>ACMX09802</b> BESCHERMTAPE 70MM (500M) TAPE DE PROTECTION 70MM (500M) SCHUTZ KLEBEBAND 70MM (500M) PROTECTIVE TAPE 70MM (500M)</p>		1

AFBEELDING IMAGE BILD PICTURE	OMSCHRIJVING DESCRIPTION BESCHREIBUNG DESCRIPTION	TOEPASSING APPLICATION ANWENDUNG APPLICATION	VERP.PER EMB.PAR PACK PR. PACK PR.
	<p><b>ACMX09803</b></p> <p>BESCHERMTAPE 100MM (500M) TAPE DE PROTECTION 100MM (500M) SCHUTZ KLEBEBAND 100MM (500M) PROTECTIVE TAPE 100MM (500M)</p>		1
	<p><b>ACMX09804</b></p> <p>BESCHERMTAPE 35MM (500M) TAPE DE PROTECTION 35MM (500M) SCHUTZ KLEBEBAND 35MM (500M) PROTECTIVE TAPE 35MM (500M)</p>		1
	<p><b>ACMX09811</b></p> <p>AFDICHTINGSTAPE 55MM RUBAN ADHÉSIF D'ÉTANCHÉITÉ 55MM AFDICHTUNGSBAND 55MM SEALING TAPE 55MM</p>	TD032	20M
	<p><b>ACMX09812</b></p> <p>AFDICHTINGSTAPE 55MM RUBAN ADHÉSIF D'ÉTANCHÉITÉ 55MM AFDICHTUNGSBAND 55MM SEALING TAPE 55MM</p>		100M
	<p><b>ACMX09830</b></p> <p>KLEEFSTOF VOOR EPDM-RUBBERS COLLE POUR EPDM-CAOUTCHOUC DICHTMASSE + KLEBESTOFF EPDM GUM FOR EPDM-RUBBER</p>		1

AFBEELDING  
IMAGE  
BILD  
PICTURE

OMSCHRIJVING  
DESCRIPTION  
BESCHREIBUNG  
DESCRIPTION

TOEPASSING  
APLPLICATION  
ANWENDUNG  
APPLICATION

VERP.PER  
EMB.PAR  
PACK PR.  
PACK PR.



## ACSIL04

1

AFDICHTINGSLIJMKIT VOOR VERSTEKNADEN  
JOINT D'ÉTANCHÉITÉ POUR ONGLETS  
LEIM FÜR ABDICHTUNG  
SEALINGGLUE



## ACSIL08

1

SILICONENPOMP  
PISTOLET DOSEUR POUR LES TUBES SILICONES  
HANDKARTUSCHENPISTOLE FÜR DIE VERARBEI-  
TUNG  
VON SILIKONE UND LEIME  
SILICONE GUN



## ACSIL013

1

LIJM VOOR VERSTEKHOEK  
COLLE POUR ONGLET  
KLEBER FÜR GEHRUNG  
GLUE FOR MITRE



## ACSIL014

1

ANTICORRO - BESCHERMINGSPRODUKT  
ANTICORRO - PRODUIT DE PROTECTION  
ANTICORRO - SCHUTZPRODUKT  
ANTICORRO - PROTECTION PRODUCT







## ACTG410



TD217

70

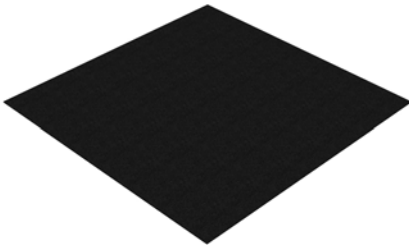
BEGLAZINGSRUBBER  
JOINT DE VITRAGE  
VERGLASUNGSDICHTUNG  
SEALING

10 MM

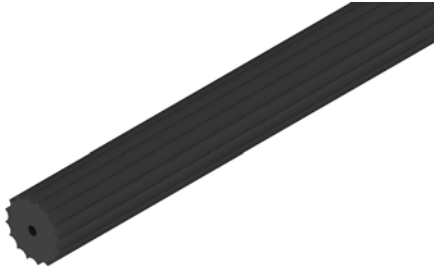
AFBEELDING IMAGE BILD PICTURE	OMSCHRIJVING DESCRIPTION BESCHREIBUNG DESCRIPTION	TOEPASSING APLPLICATION ANWENDUNG APPLICATION	VERP.PER EMB.PAR PACK PR. PACK PR.
	<p><b>ACUN033</b></p> <p>BINNENBEGLAZINGSDICHTING JOINT DE VITRAGE INTERIEUR INNENVERGLASUNGSDICHTUNG INNER GLAZING GASKET</p> <p>3 - 5 MM</p>		100 M
	<p><b>ACUN036</b></p> <p>BINNENBEGLAZINGSDICHTING JOINT DE VITRAGE INTERIEUR INNENVERGLASUNGSDICHTUNG INNER GLAZING GASKET</p> <p>6 - 8 MM</p>		100 M
	<p><b>ACVL159</b></p> <p>SECONDENLIJM COLLE RAPIDE SEKUNDENLEIM CONTACTGLUE</p>		1
	<p><b>ACVR140</b></p> <p>ZELFKLEVENDE EPDM EPDM AUTOCOLLANT EPDM SELBSTKLEBEND ADHESIVE SEALING</p> <p>500 x 500 x 2.5 MM</p>	<p>ACTD011 ACTD012 ACTD015 ACTD020 ACTD021 ACTD022 ACTD024 ACTD025 ...</p>	1
	<p><b>ACVR216</b></p> <p>SCHROEF MET AFDEKKAP VIS AVEC CAPUCHON SCHRAUBE MIT ABDECKKAPPE SCREW WITH FACE CAP</p>	<p>ACTD011 ACTD012 ACTD015 ACTD020 ACTD021 ACTD022 ACTD024 ACTD025 ...</p>	100

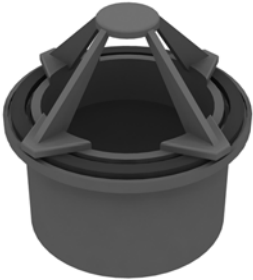
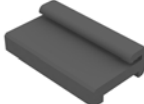
AFBEELDING IMAGE BILD PICTURE	OMSCHRIJVING DESCRIPTION BESCHREIBUNG DESCRIPTION	TOEPASSING APLPLICATION ANWENDUNG APPLICATION	VERP.PER EMB.PAR PACK PR. PACK PR.
	<p><b>ACVR216</b></p> <p>VERHOOGDE DICHTINGSRUBBER GOOT JOINT D'ETANCHEITE GOUTTIERE GRAND HOCH AFDICHTUNGSGUMMI RINNE HIGH SEALING STRIP GUTTER</p>	<p>VR190 TD565</p>	<p>50</p>
	<p><b>ACVR503</b></p> <p>INROLPEES TENDEUR KEDER GASKET</p>	<p>TD021 TD022 TD023</p>	<p>200M</p>
	<p><b>ACVR620</b></p> <p>BEGLAZINGSRUBBER JOINT DE VITRAGE VERGLASUNGSDICHTUNG GASKET</p>	<p>VR190</p>	<p>100M</p>
	<p><b>ACVR2227</b></p> <p>UITLOOP DAKGOOT CREPINE GOUTTIERE REGENABFUEHRABSCHLUSS DACHRINNE CONNECTION PIECE GUTTER DRAINPIPE</p>	<p>TD020 TD023</p>	<p>1</p>
	<p><b>ACVR2727</b></p> <p>EPDM ONDERVULLING VERHOOGPROFIEL CALE EPDM POUR REHAUSSE ET DRAINAGE KEIL FUR ERHOHUNG UND ENTWASSERUNG SPACER FOR RAISE PROFILE AND DRAINAGE</p>	<p>TD020 TD023 VR224</p>	<p>1</p>

AFBEELDING IMAGE BILD PICTURE	OMSCHRIJVING DESCRIPTION BESCHREIBUNG DESCRIPTION	TOEPASSING APPLICATION ANWENDUNG APPLICATION	VERP.PER EMB.PAR PACK PR. PACK PR.
	<p><b>ACVR6031</b></p> <p>VERBINDINGSSTUK PIÈCE DE RACCORD VERBINDUNGSSTÜCK COUPLING PIECE</p>	TD030	1
	<p><b>ACVR6032</b></p> <p>VERBINDINGSSTUK PIÈCE DE RACCORD VERBINDUNGSSTÜCK COUPLING PIECE</p>	TD030	1

TOEBEHOREN - ACCESSOIRES - ZUBEHÖRTEILE - ACCESSORIES





Aliplast intern
P.O.: _____
Ordernr.: _____
Leveran.: _____
Dat. Lev.: _____

ACTD120	AANTAL NOMBRE ANZALH NUMBER
A = _____ °	
L = _____ mm	

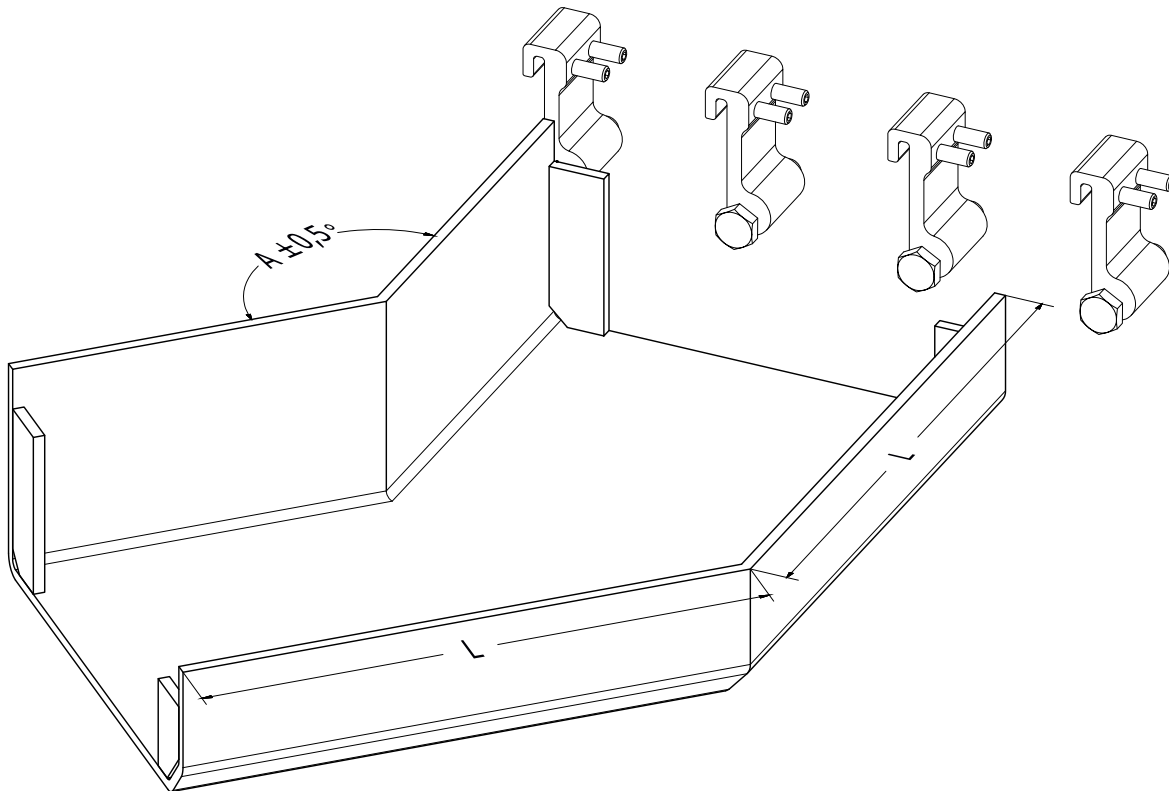
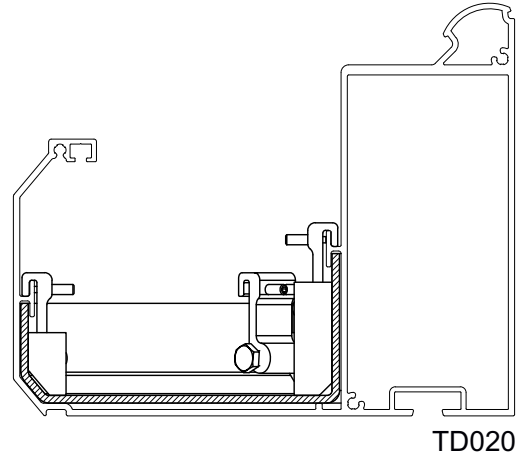

**TOEBEHOREN - ACCESSOIRES - ZUBEHÖRTEILE - ACCESSORIES**

ACTD120

Aliplast intern
P.O.: _____
Ordernr.: _____
Leveran.: _____
Dat. Lev.: _____

ACTD122	AANTAL NOMBRE ANZALH NUMBER
A = _____ °	
L = _____ mm	

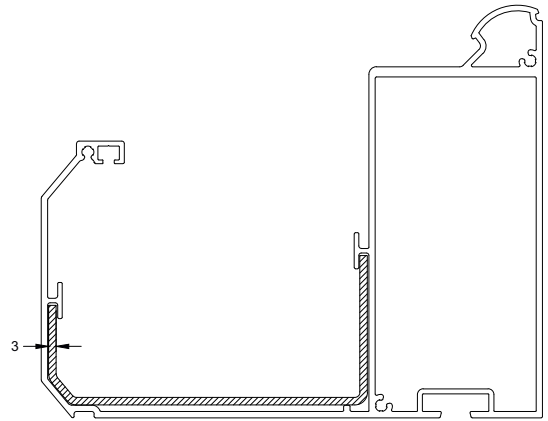

TD020 / TD023

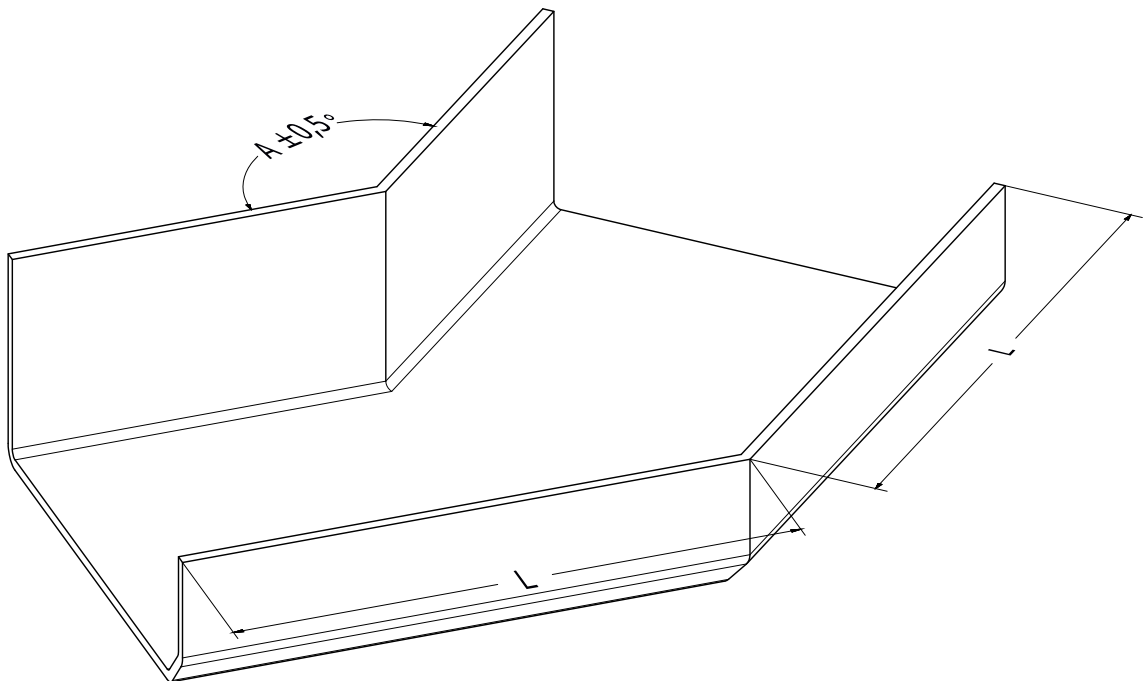

ACTD122

ALGEMENE INFORMATIE  
GENERALITES  
ALGEMEINE INFORMATION  
GENERAL INFORMATION

## BELASTING

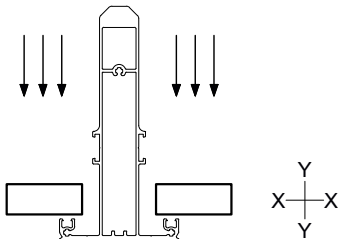

De positie van het assenkruis is een indicatie voor het gebruik en de toepassing van de traagheidsmomenten ( $I_x$  en  $I_y$ ) en de weerstandsmomenten ( $W_x$  en  $W_y$ ). We kiezen steeds de waarden van de as die loodrecht staat op de belasting om te weerstaan aan deze belasting.

- om te weerstaan aan de belasting door het glasgewicht en extra belasting gebruiken we de waarden  $I_y$  en  $W_y$

## CHARGES

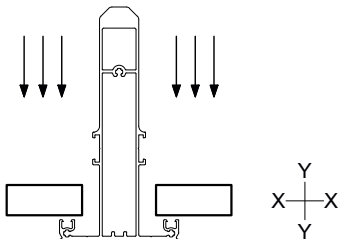

La position des axes X et Y est une indication à l'utilisation et l'application des moments d'inertie ( $I_x$  et  $I_y$ ) et des moments de resistance ( $W_x$  et  $W_y$ ). Nous choisissons toujours les valeurs de l'axe perpendiculaire à la charge de résister afin de pouvoir calculer la resistance.

- De supporter le poids de verre et de la charge supplémentaire, nous utilisons les valeurs  $I_y$  et  $W_y$

## LASTEN

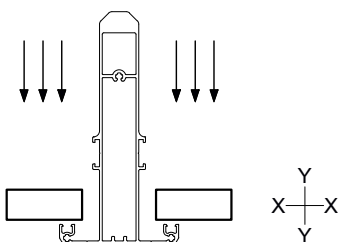

Die Position der Achsen ist ein Indiz für die Nutzung und Anwendung der Trägheitsmomente ( $I_X$  und  $I_Y$ ) und Modulus ( $W_x$  und  $W_y$ ). Wir wählen immer die Werte der Achse senkrecht zur Last an das Finanzamt zu widerstehen.

- Um den Stress zu widerstehen von Glas und extra Lasten verwenden wir die Werte  $I_y$  und  $W_y$

## LOAD

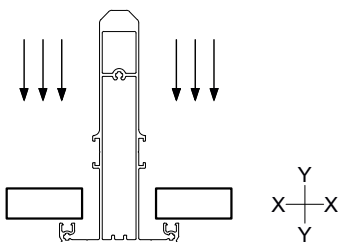

The position of the axes is an indication for the use and application of the moments of inertia ( $I_x$  and  $I_y$ ) and the section modulus ( $W_x$  and  $W_y$ ). We always choose the values of the axis perpendicular to the load to resist it.

- To withstand the weight of the glass and other loads we use the values and  $I_y$  and  $W_y$

INFO\_lxly

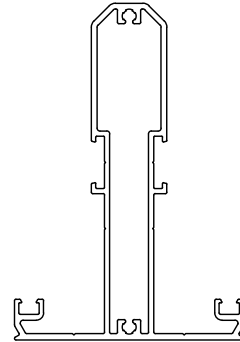
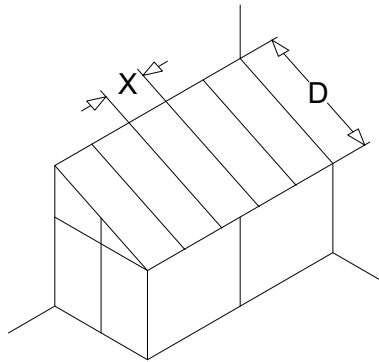

**TD111**  
 $I_x: 130.3 \text{ cm}^4$   
 $f_{\text{max}} = L/200$

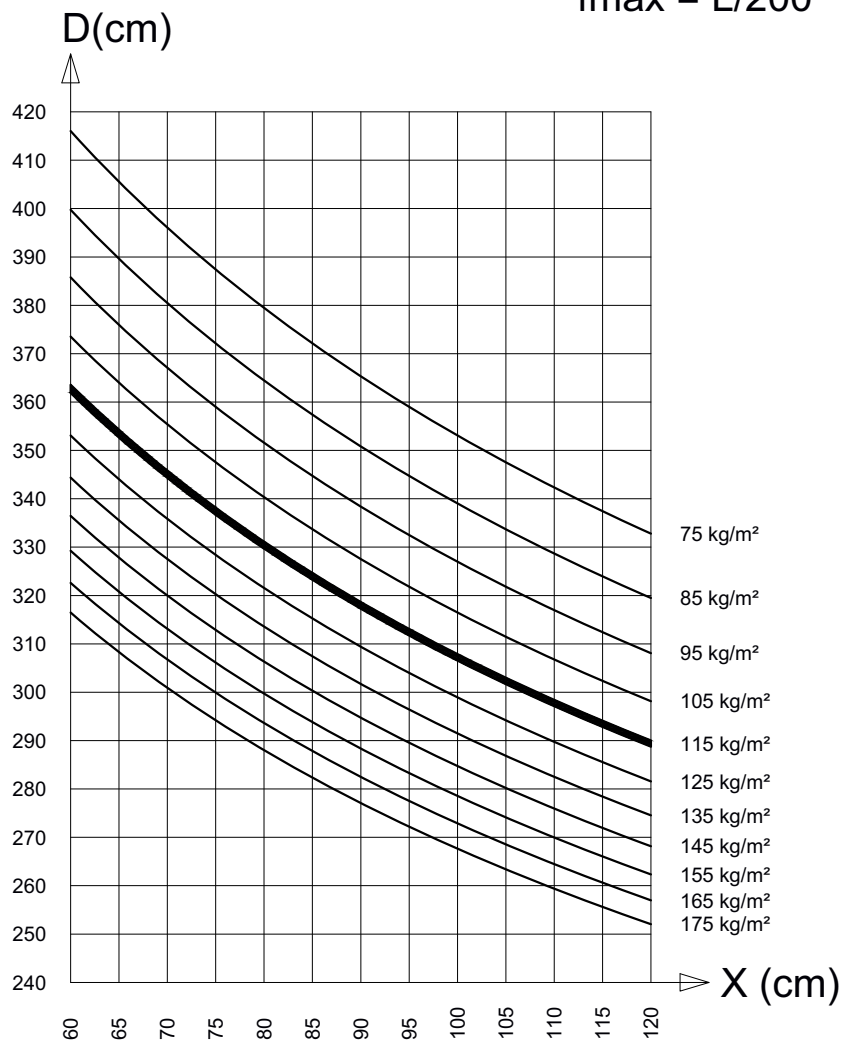

TD111

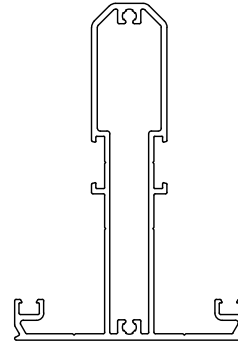
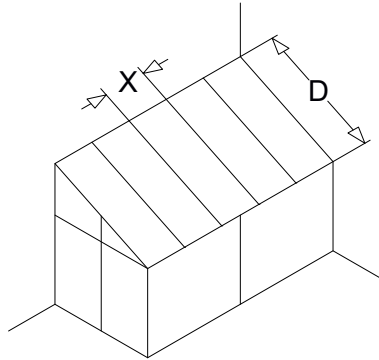

**TD111**  
 $I_x: 130.3 \text{ cm}^4$   
 $f_{max} = 8\text{mm}$

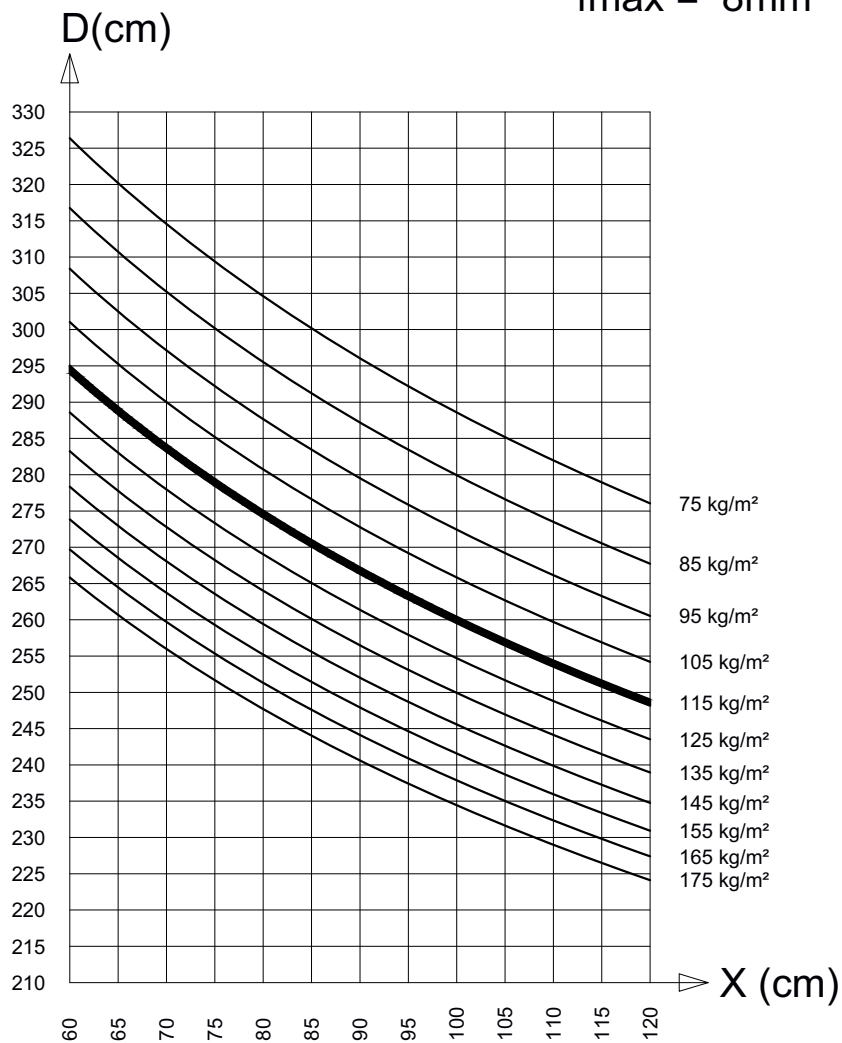

TD111\_fmax8

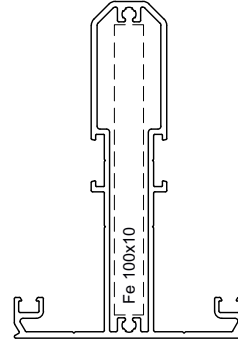
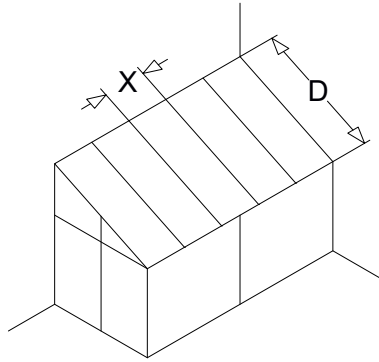

TD111 + P100x10 (Fe)  
 $I_x: 380.3 \text{ cm}^4$   
 $f_{max} = L/200$

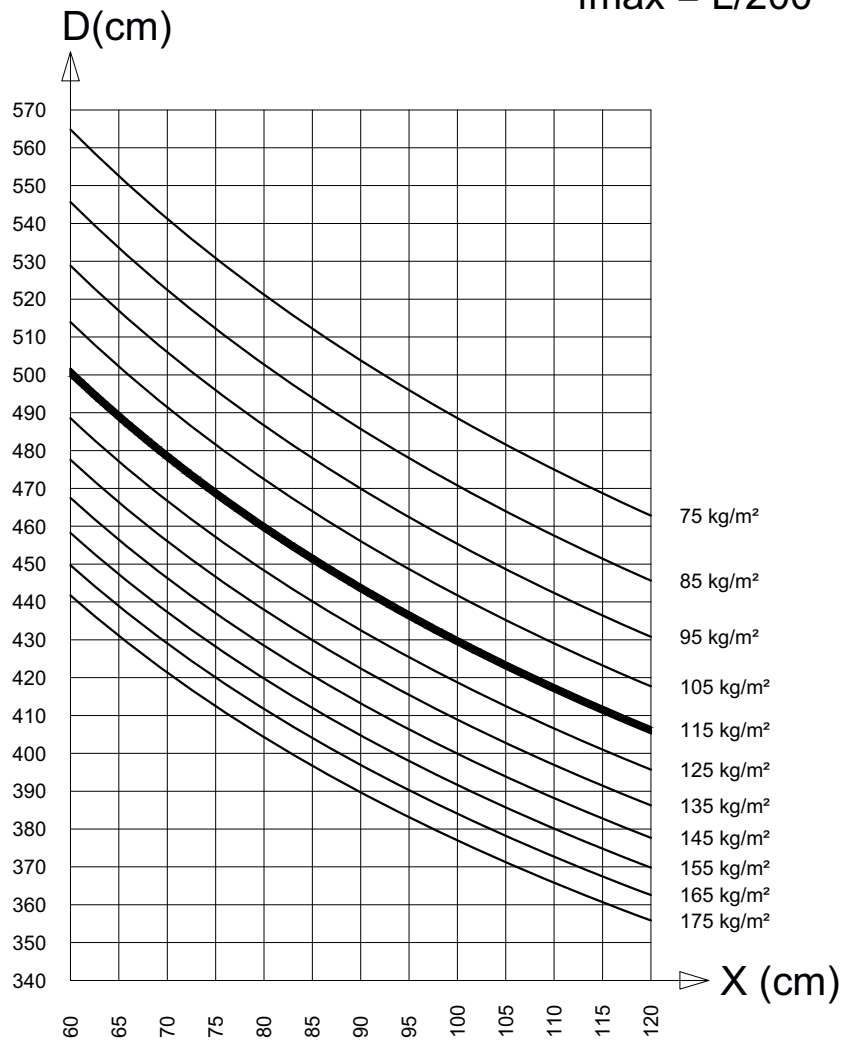

TD111+1P100x10

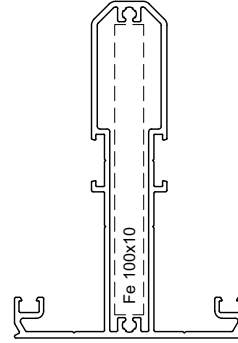
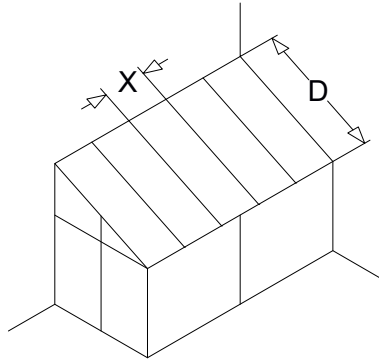

TD111 + P100x10 (Fe)  
 $I_x: 380.3 \text{ cm}^4$   
 $f_{max} = 8 \text{ mm}$

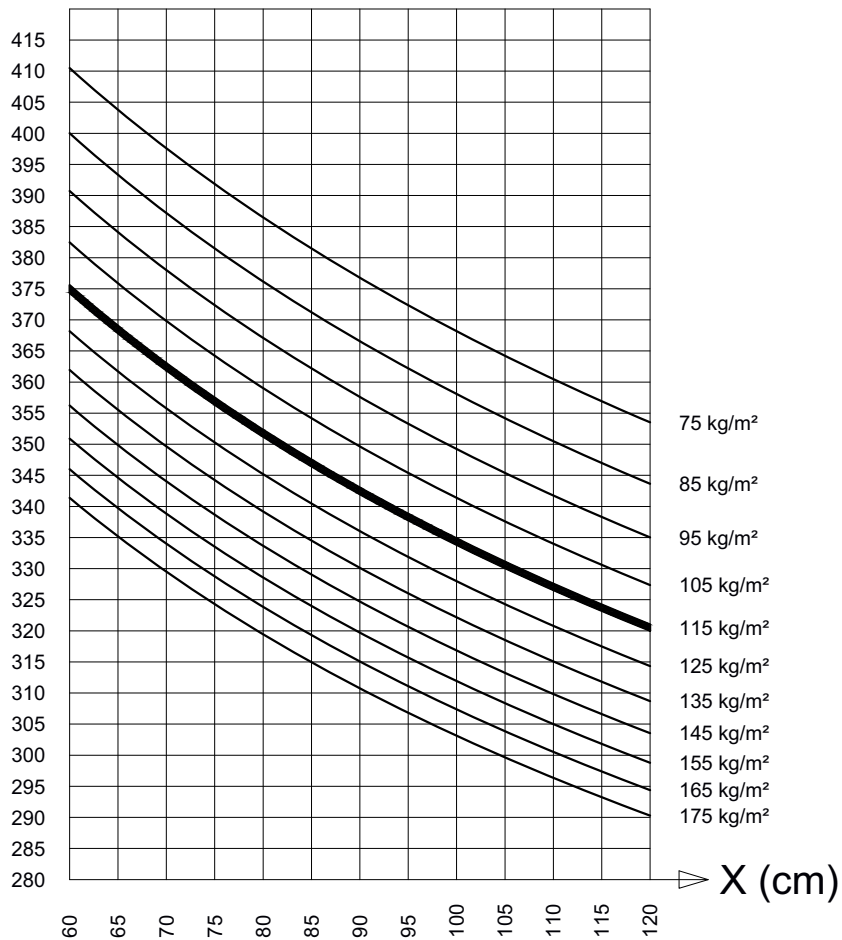

TD111+1P100x10\_fmax8

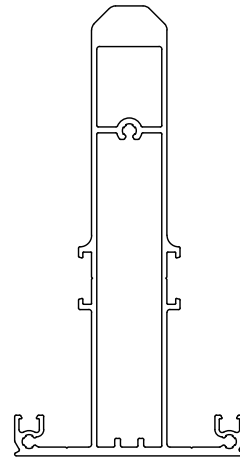
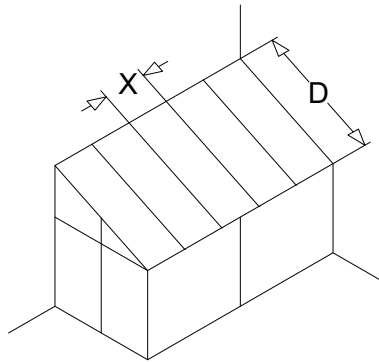

**TD011**  
 $I_x: 424.1 \text{ cm}^4$   
 $f_{max} = L/200$

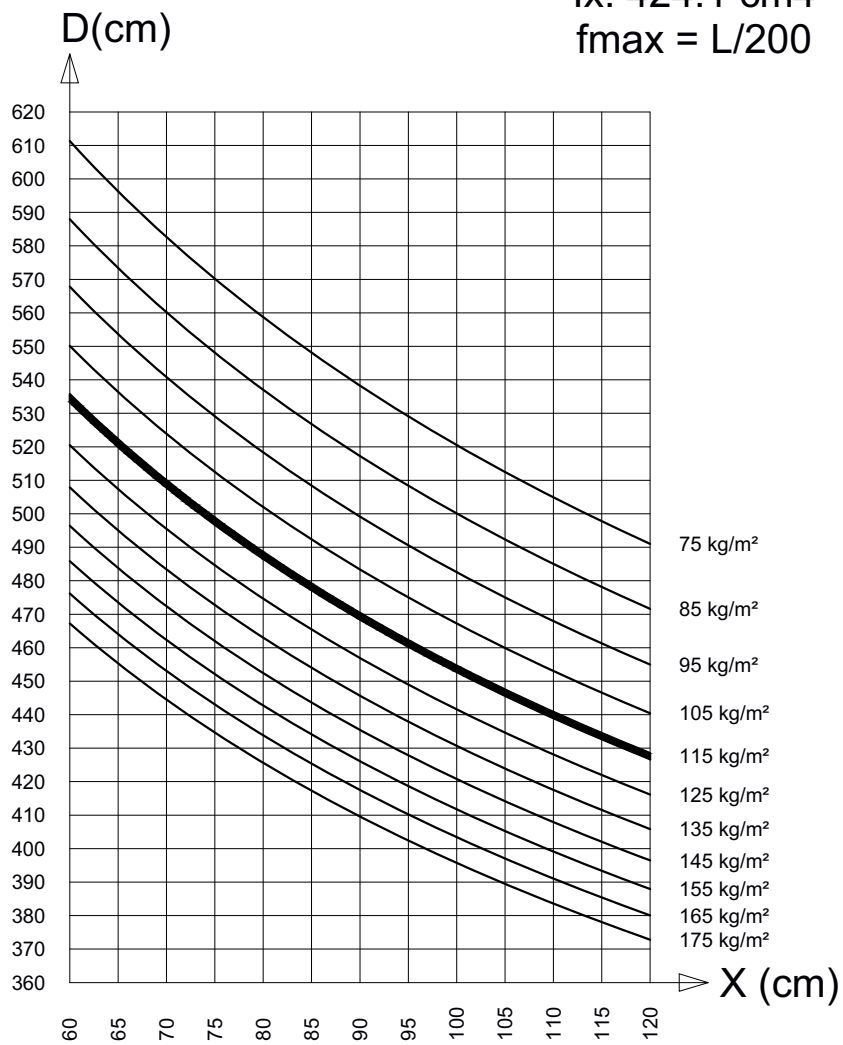

TD011



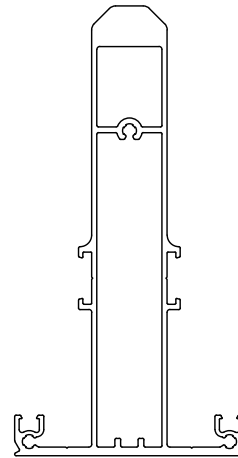
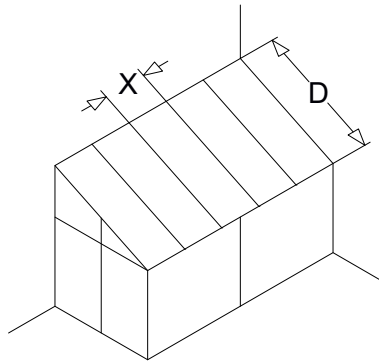

**TD011**  
 $I_x: 424.1 \text{ cm}^4$   
 $f_{max} = 8 \text{ mm}$

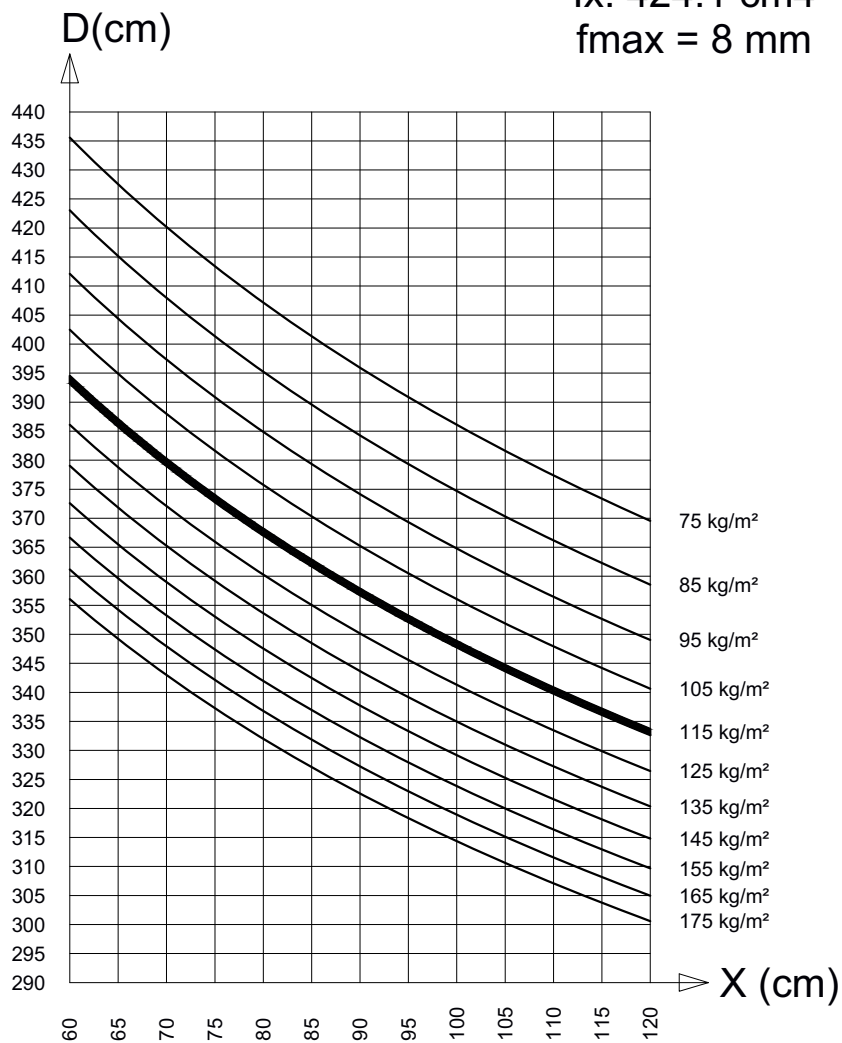

TD011\_fmax8

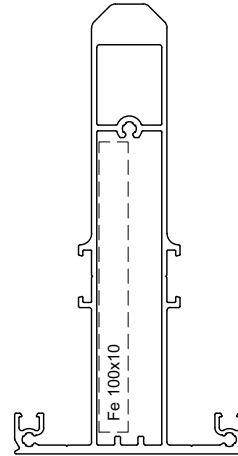
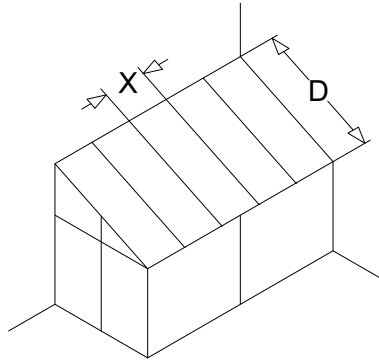

TD011 + P100x10 (Fe)  
 $I_x: 674.1 \text{ cm}^4$   
 $f_{max} = L/200$

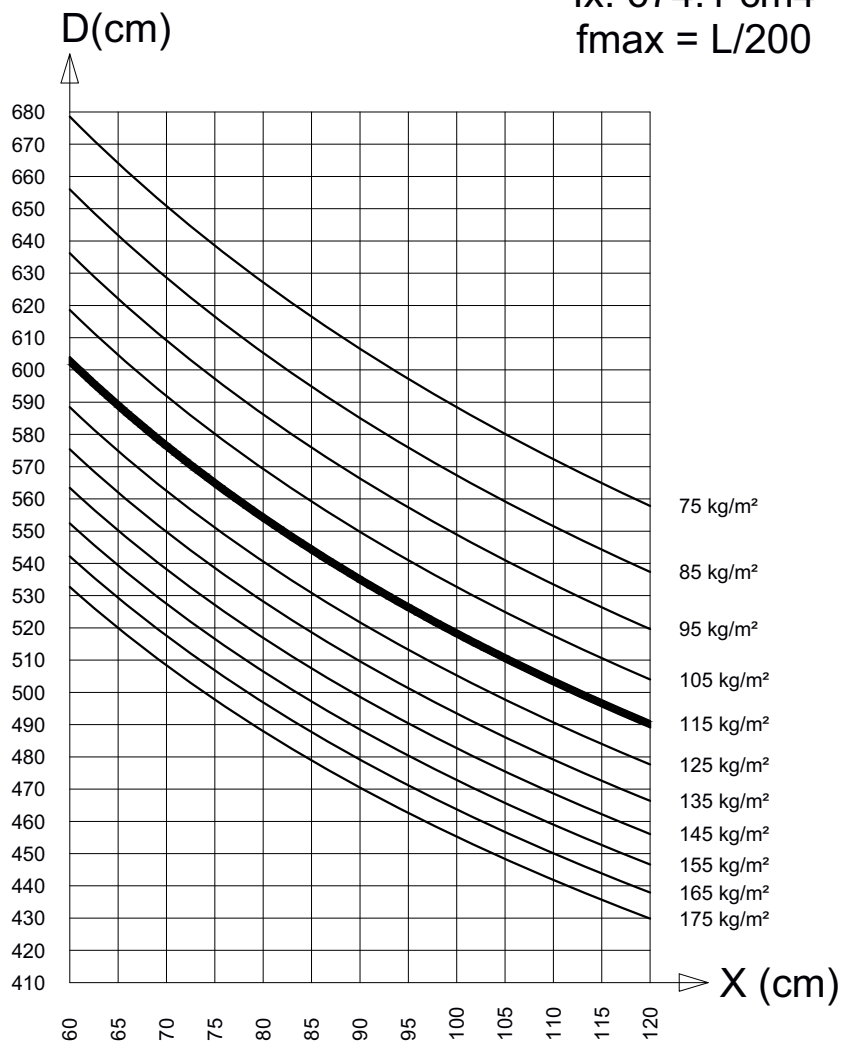

TD011+1P100x10

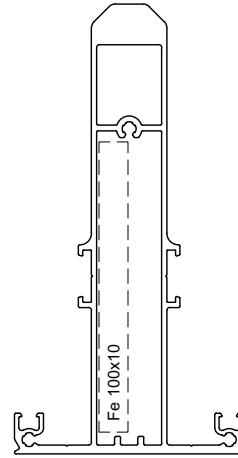
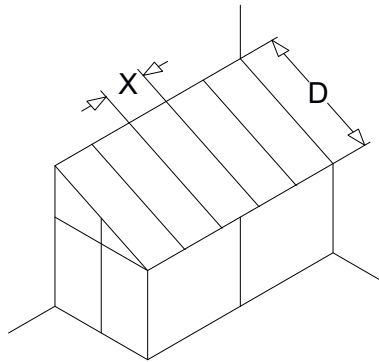

TD011 + P100x10 (Fe)  
 $I_x: 674.1 \text{ cm}^4$   
 $f_{max} = 8 \text{ mm}$

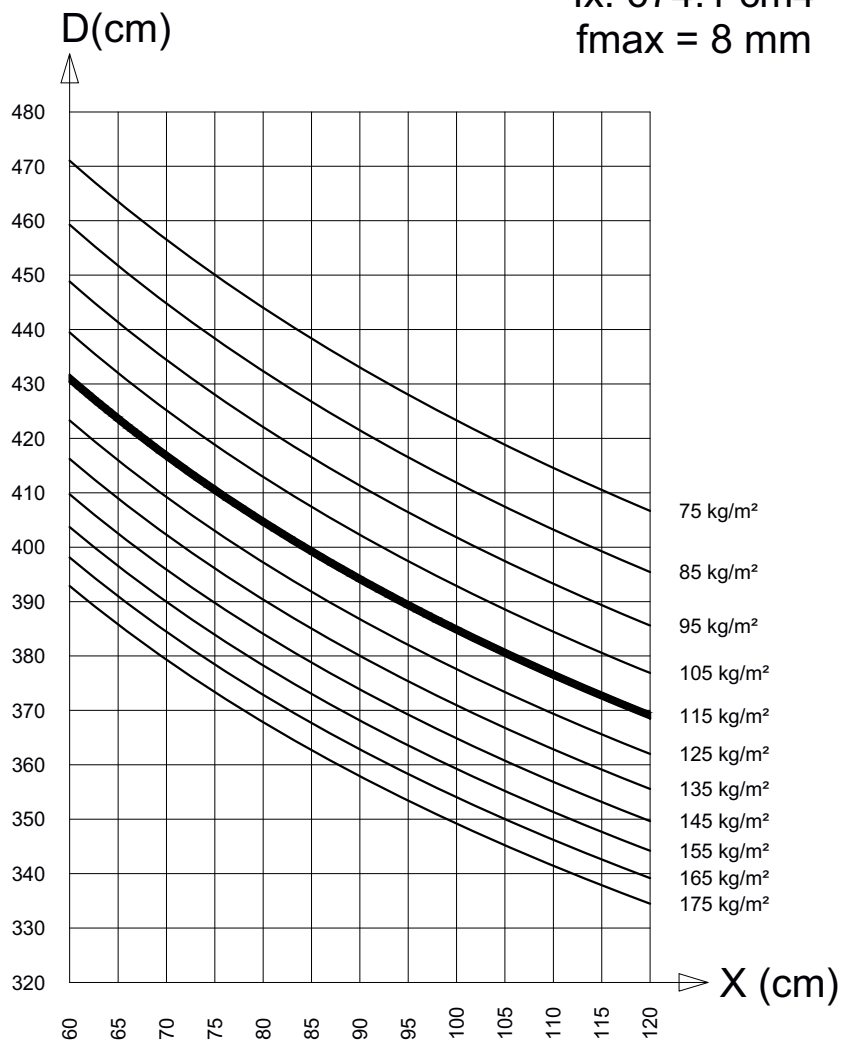

TD011+1P100x10\_fmax8

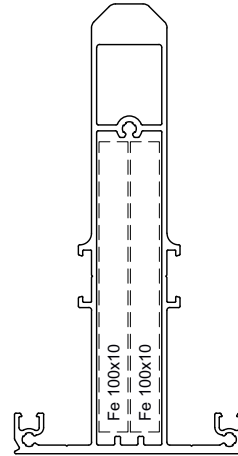
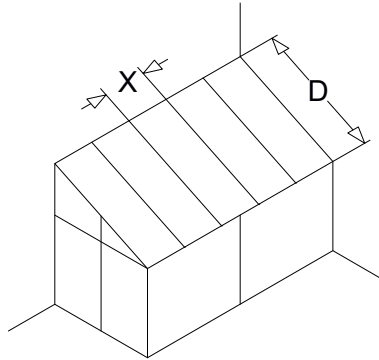

TD011 + 2 x P100x10 (Fe)  
 $I_x: 924.1 \text{ cm}^4$   
 $f_{max} = L/200$

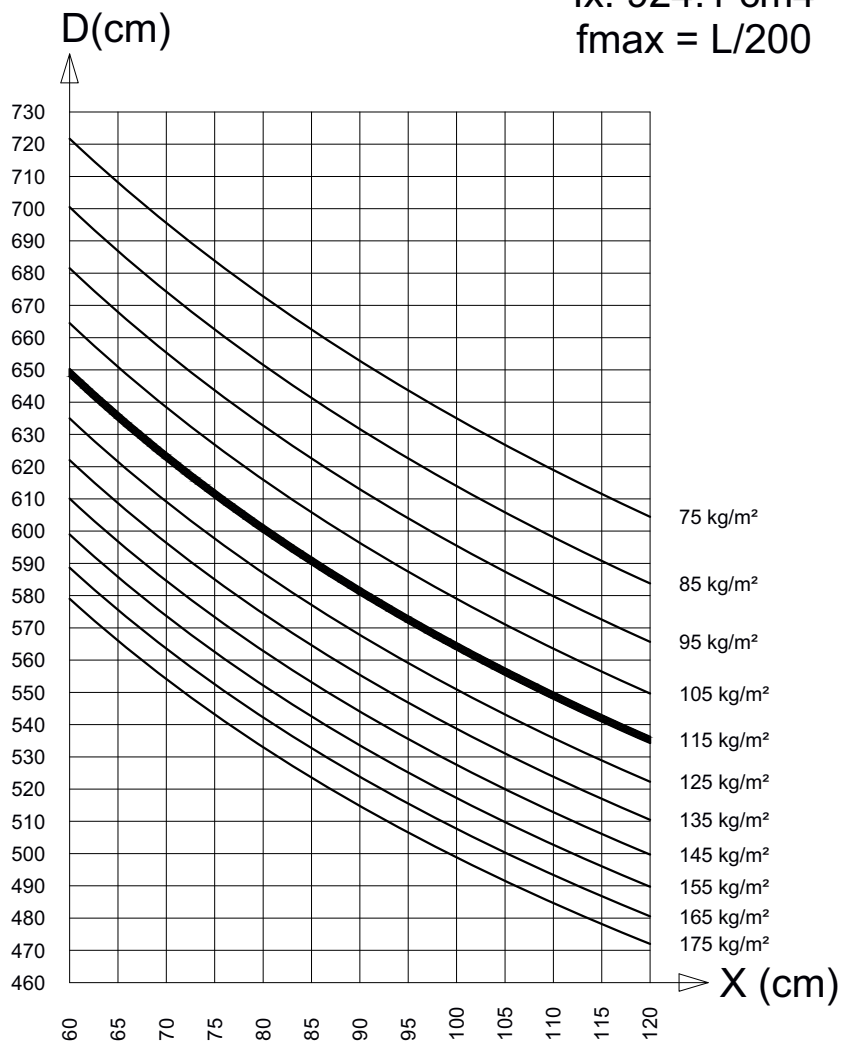

TD011+2P100x10

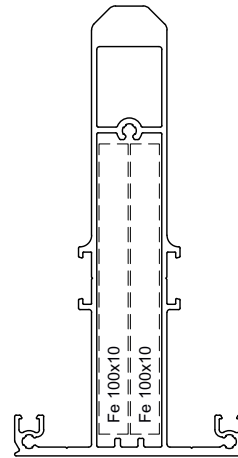
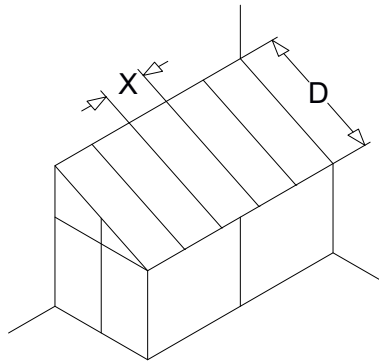

TD011 + 2 x P100x10 (Fe)  
 $I_x: 924.1 \text{ cm}^4$   
 $f_{max} = 8 \text{ mm}$

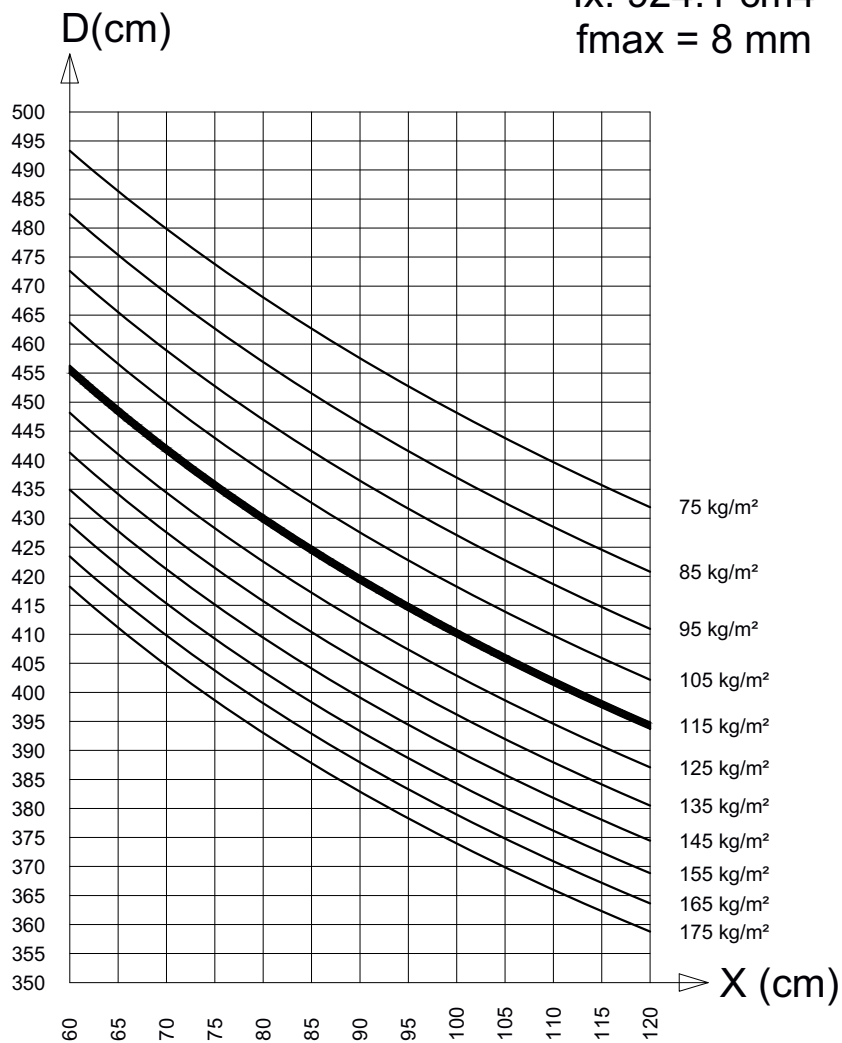

TD011+2P100x10\_fmax8

**aliplast**  
 member of



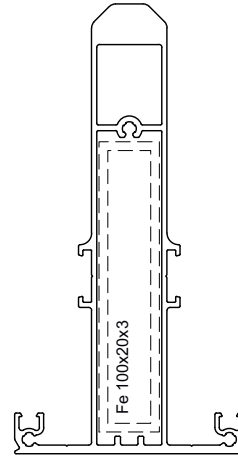
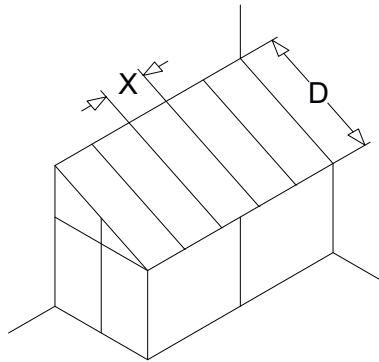

TD011 + R100x20x3 (Fe)  
 $I_x: 633.4 \text{ cm}^4$   
 $f_{\text{max}} = L/200$

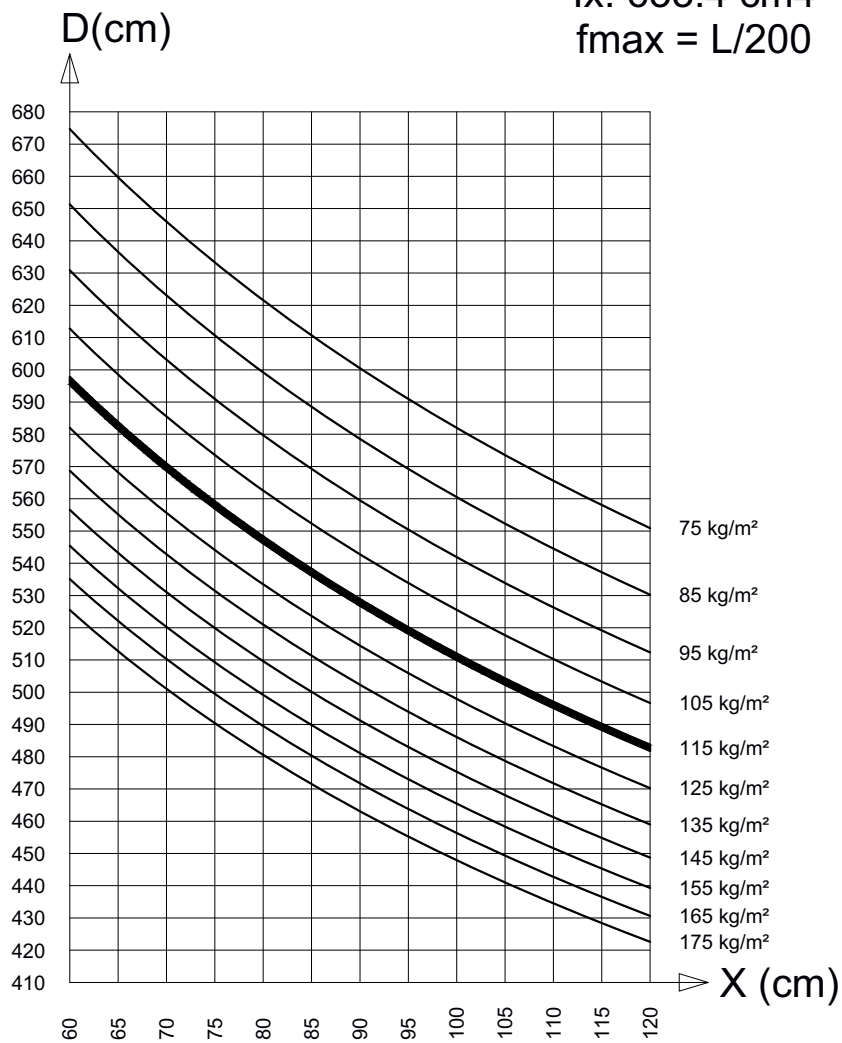

TD011+1R100x20x3

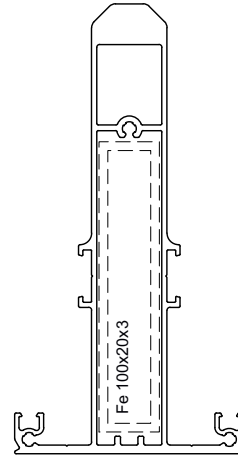
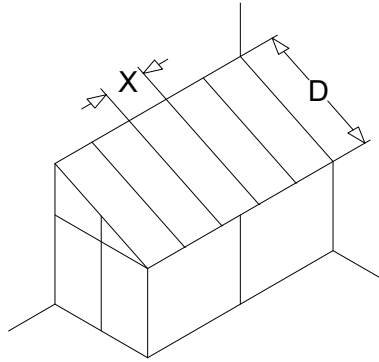

TD011 + R100x20x3 (Fe)  
 $I_x: 633.4 \text{ cm}^4$   
 $f_{max} = L/200$

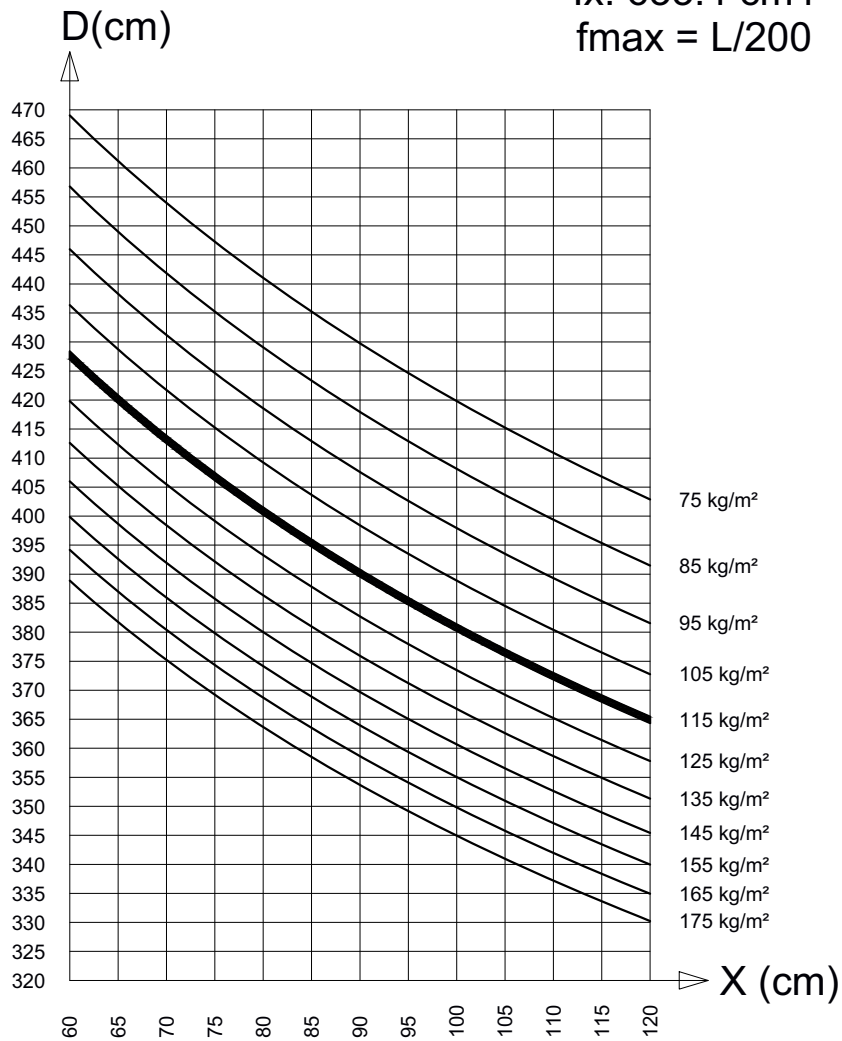

TD011+1R100x20x3\_fmax8



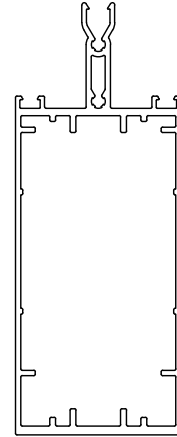
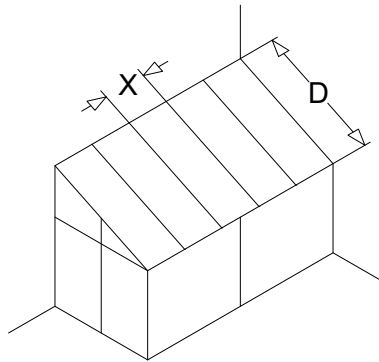

**ER011**  
 $I_x: 236.3 \text{ cm}^4$   
 $f_{max} = L/200$

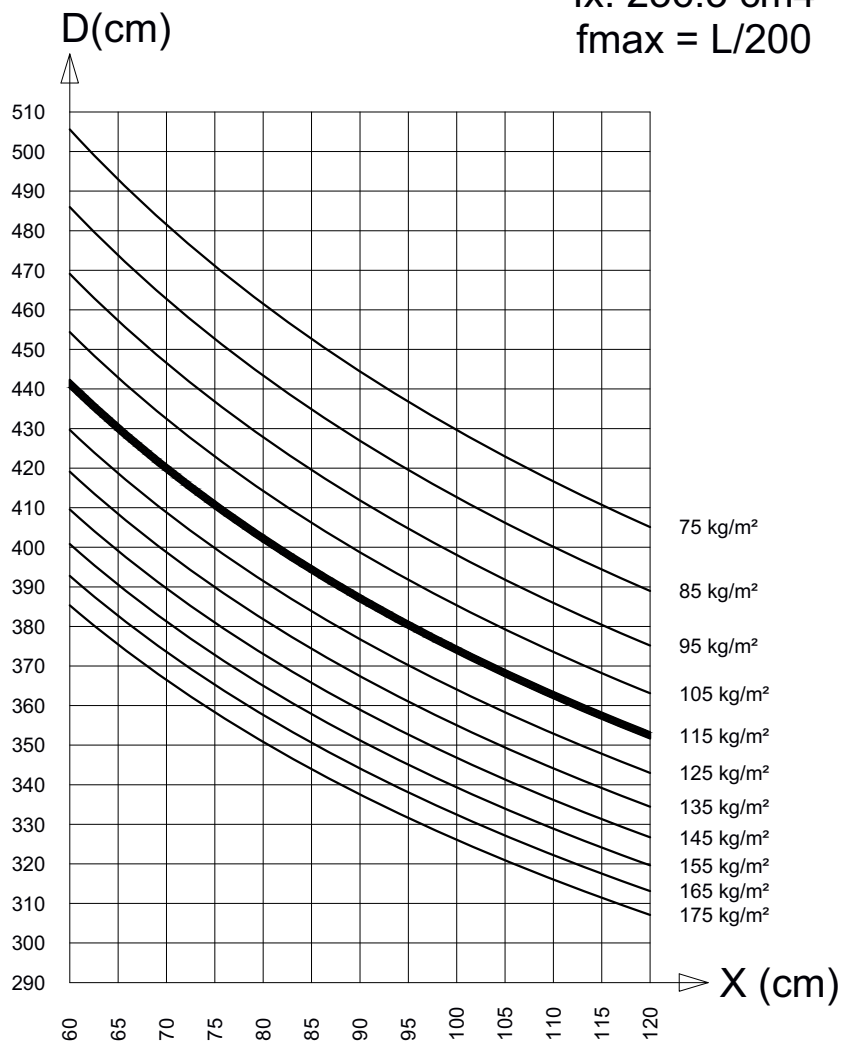

ER011



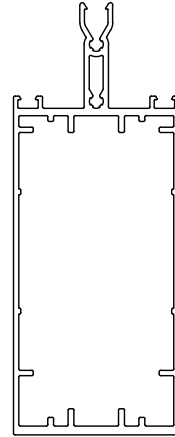
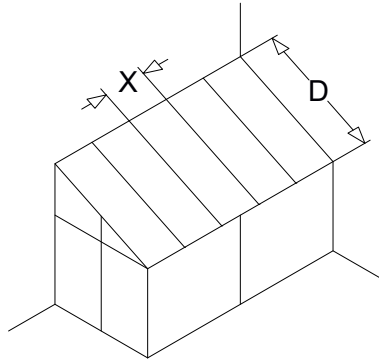

**ER011**  
 $I_x: 236.3 \text{ cm}^4$   
 $f_{max} = 8 \text{ mm}$

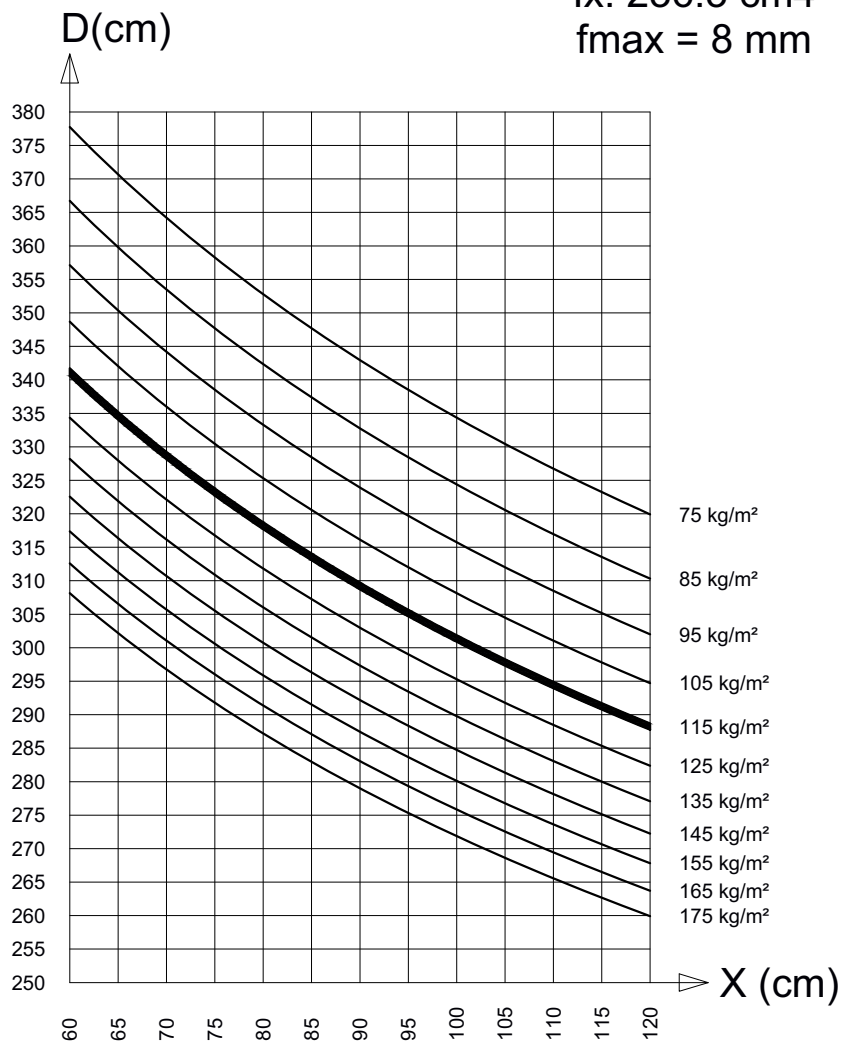

ER011\_fmax8

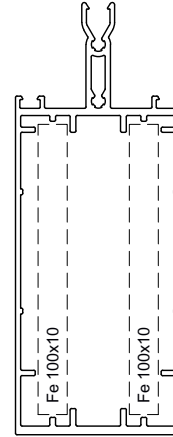
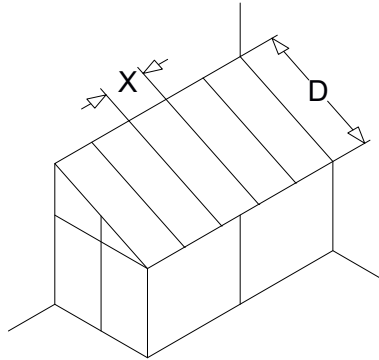

ER011+2P100x10 (Fe)  
 $I_x: 736.3 \text{ cm}^4$   
 $f_{max} = L/200$

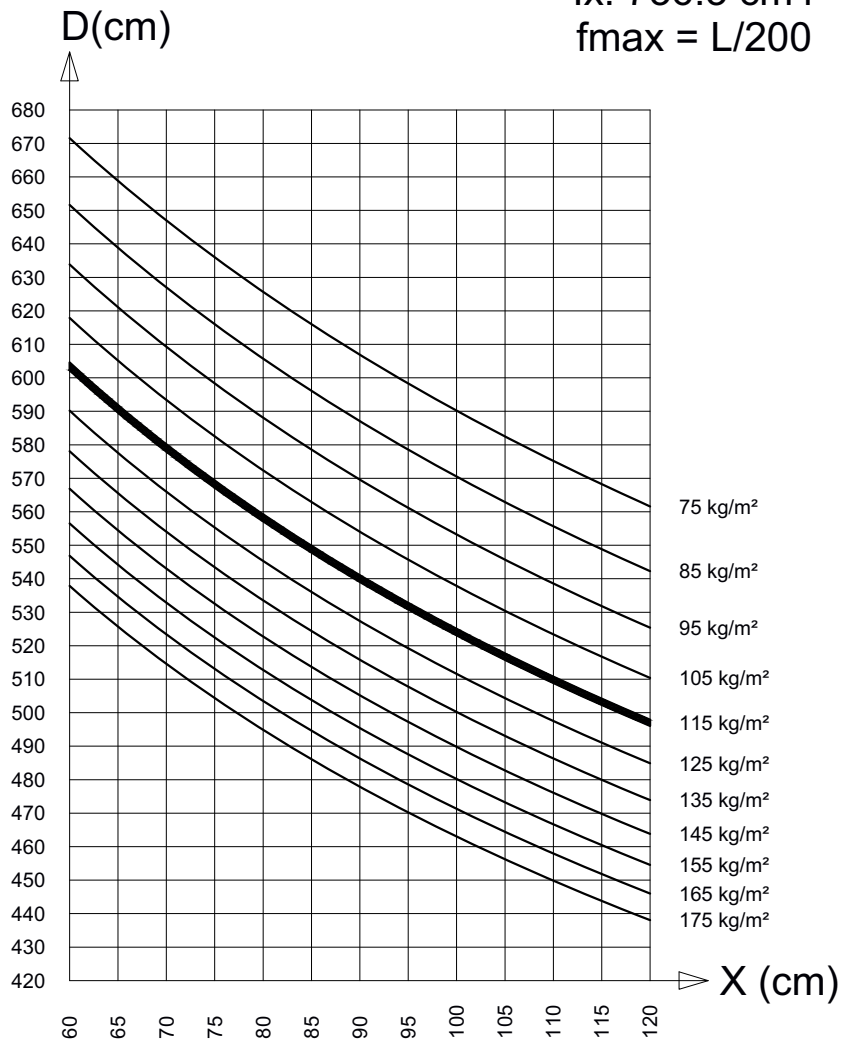

ER011+1P100x10

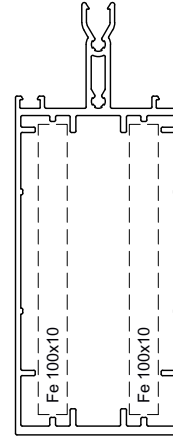
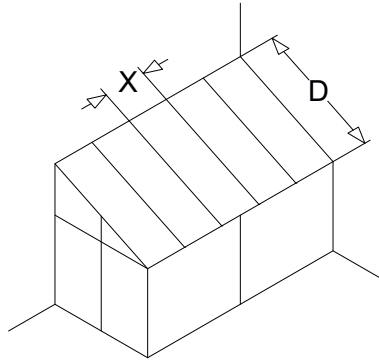

ER011+2P100x10 (Fe)  
 $I_x: 736.3 \text{ cm}^4$   
 $f_{max} = 8\text{mm}$

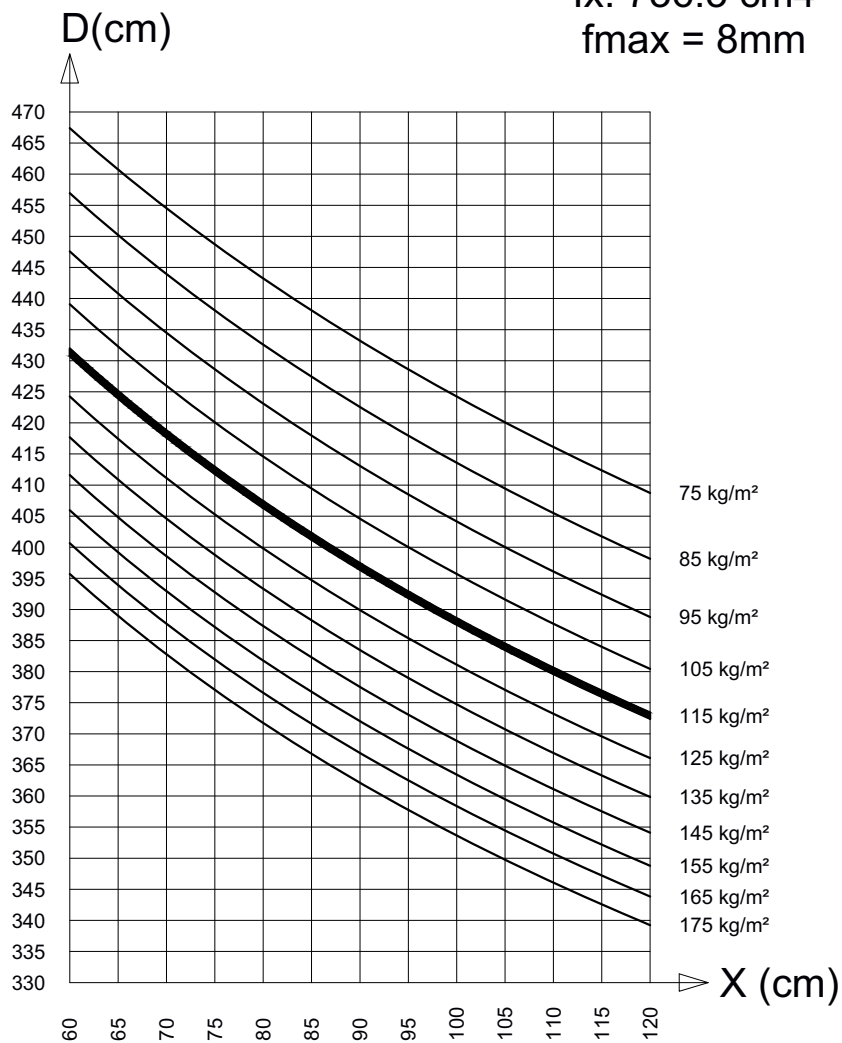

ER011+1P100x10\_fmax8

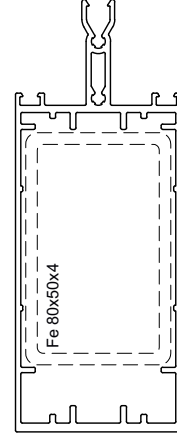
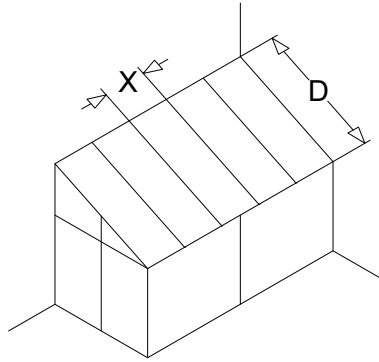

ER011+1R80x50x4 (Fe)<sub>(VR061)</sub>  
 $I_x: 481.2 \text{ cm}^4$   
 $f_{max} = L/200$

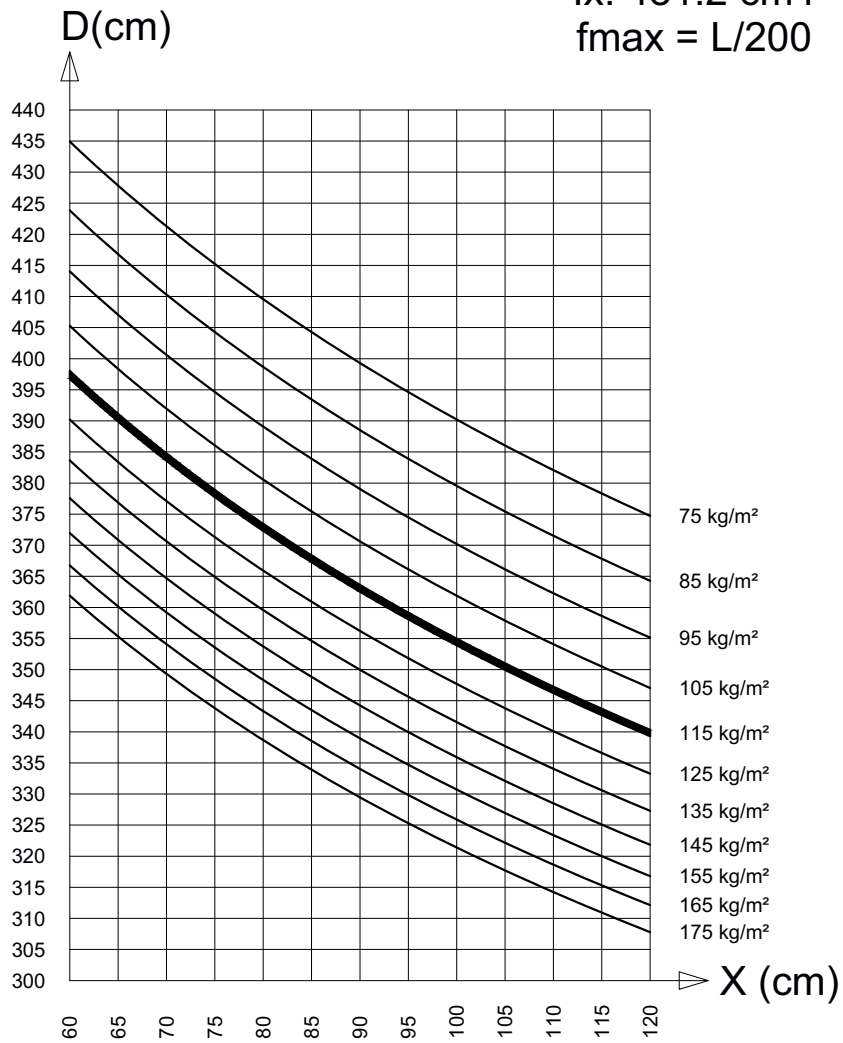

ER011+VR061

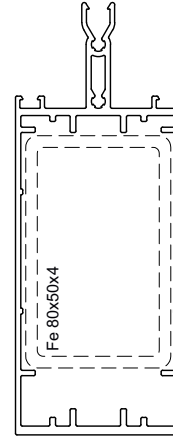
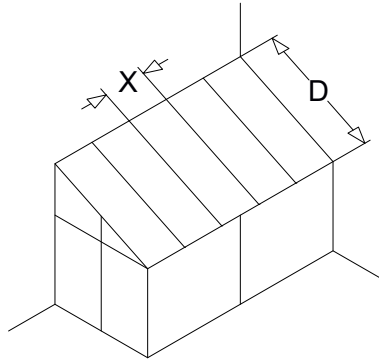

ER011+1R80x50x4 (Fe)<sub>(VR061)</sub>  
 $I_x: 481.2 \text{ cm}^4$   
 $f_{max} = 8 \text{ mm}$

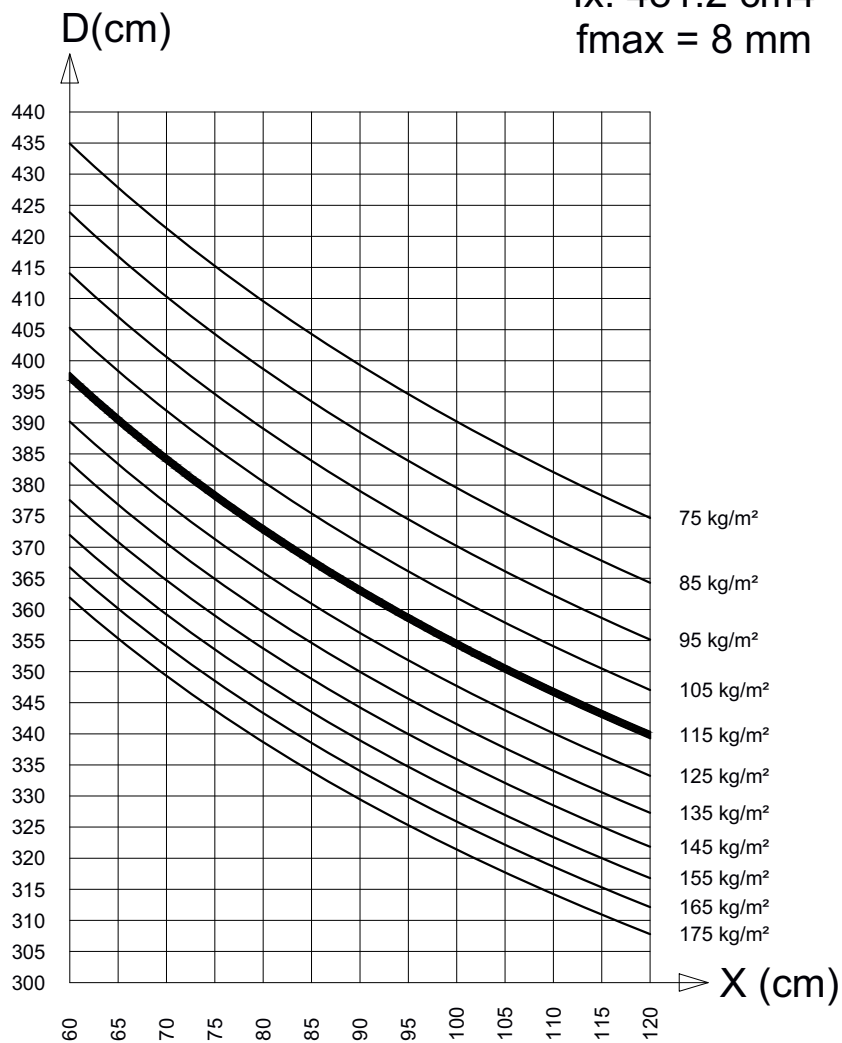

STATICA - STATIQUE - STATIK - STATICS

ER011+VR061\_fmmax8



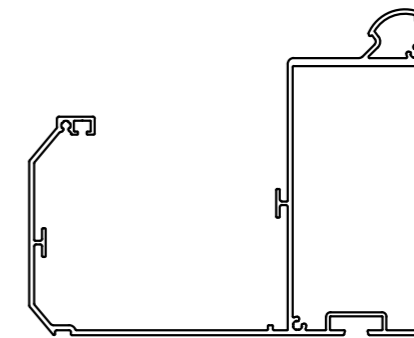
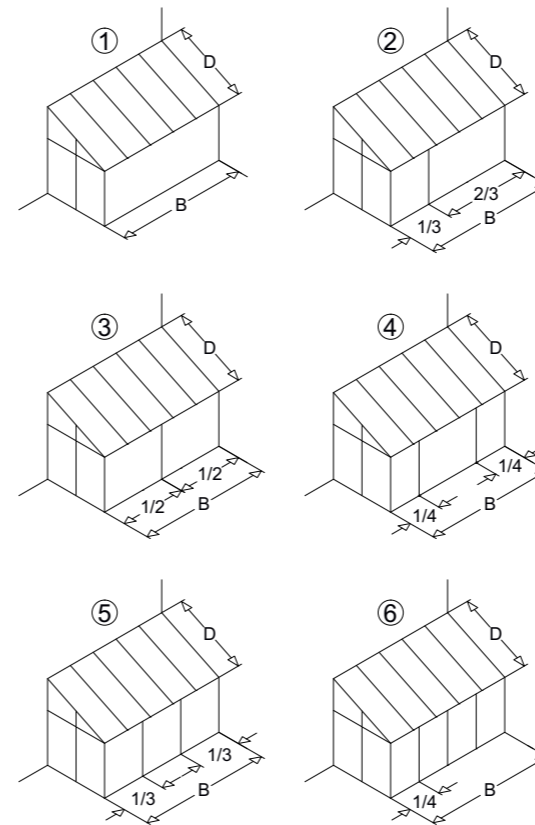
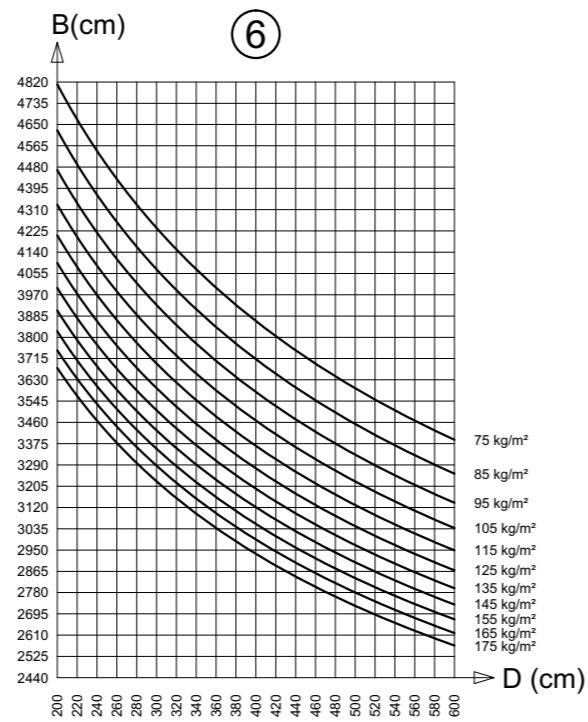
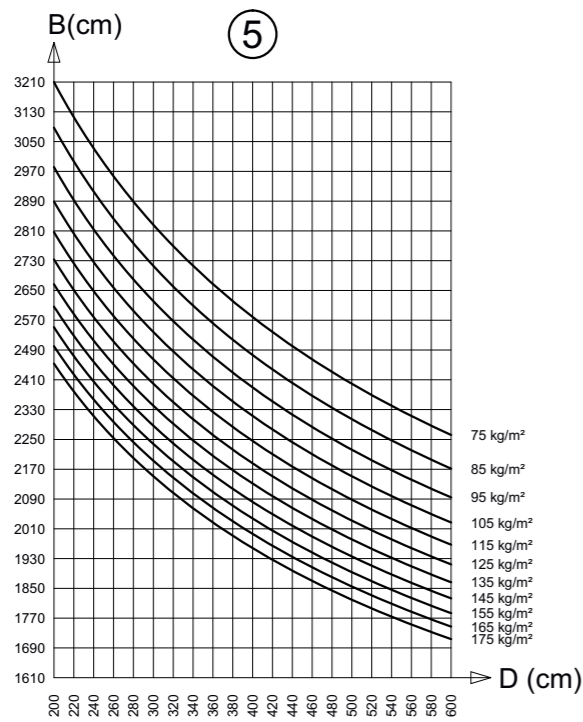
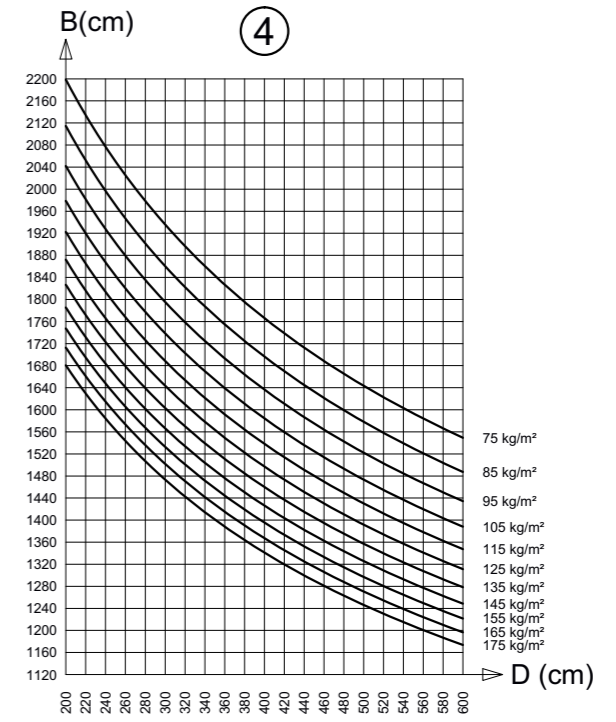
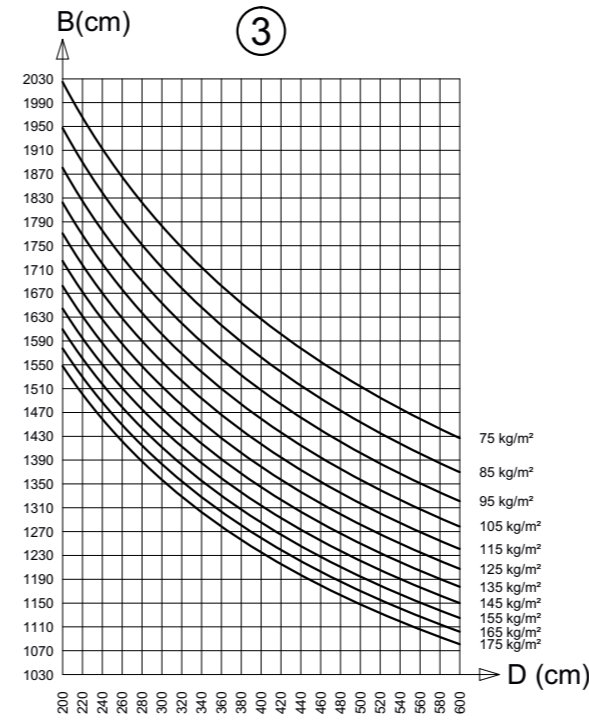
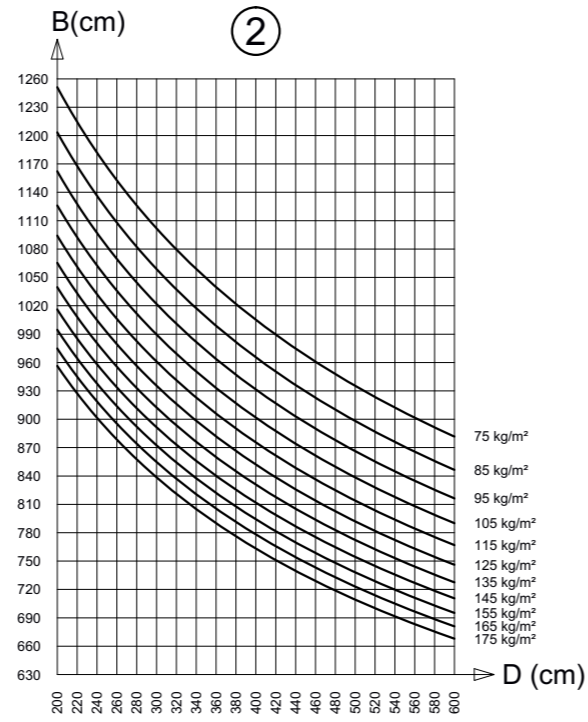
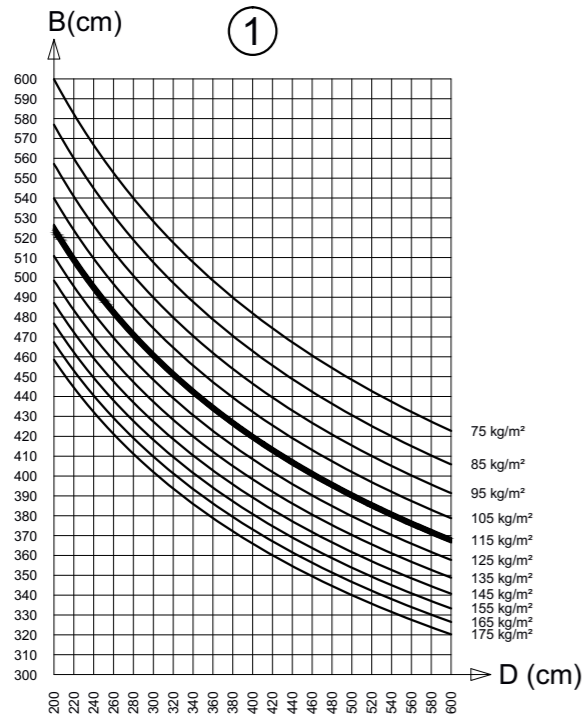

TD020  
Ix: 638.5 cm<sup>4</sup>  
fmax: L/200

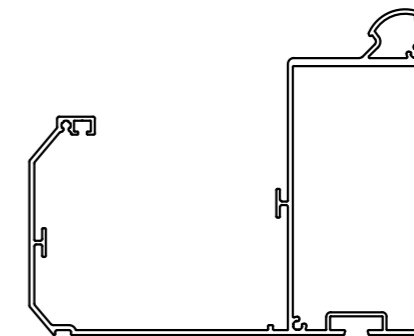
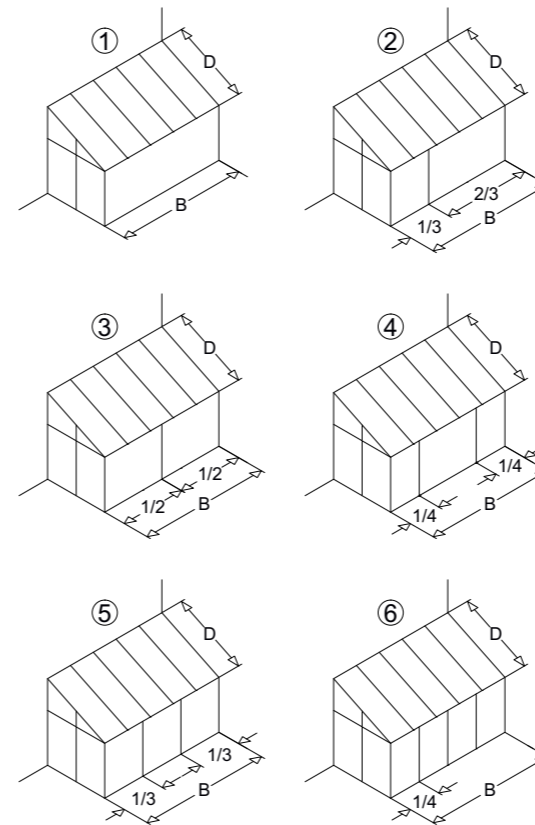
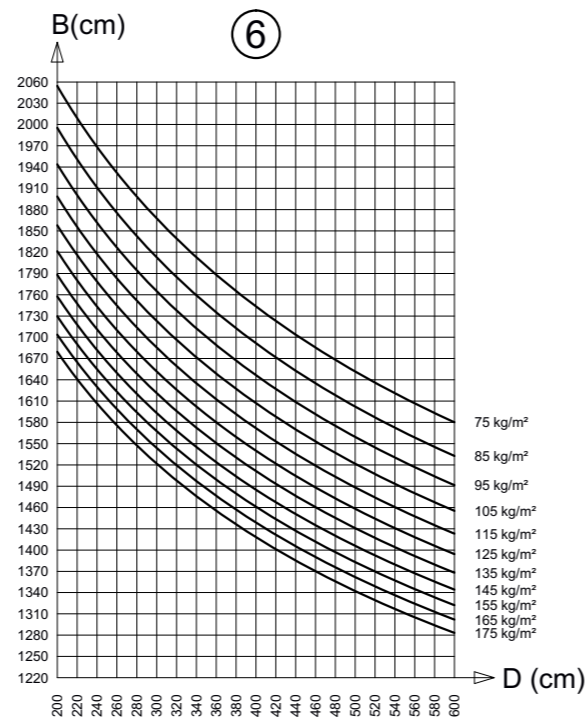
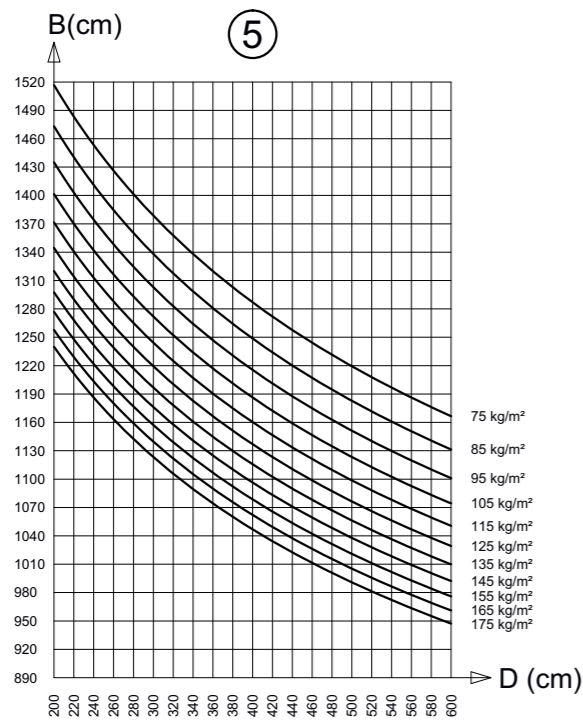
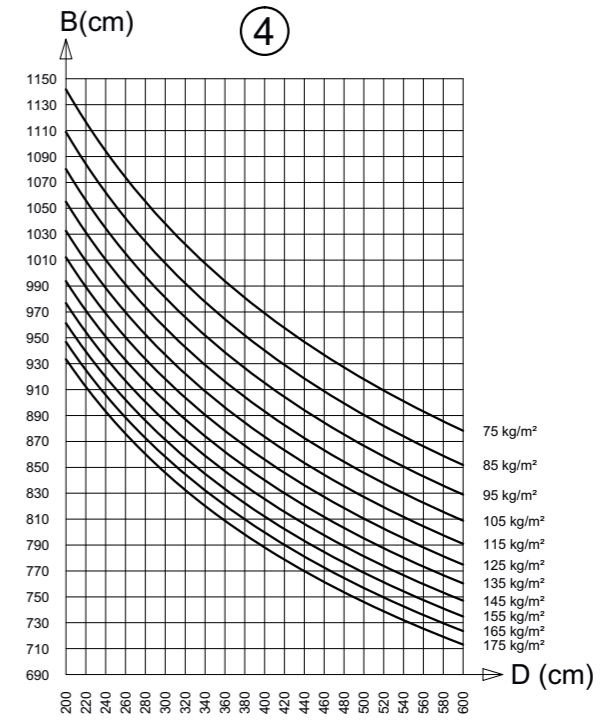
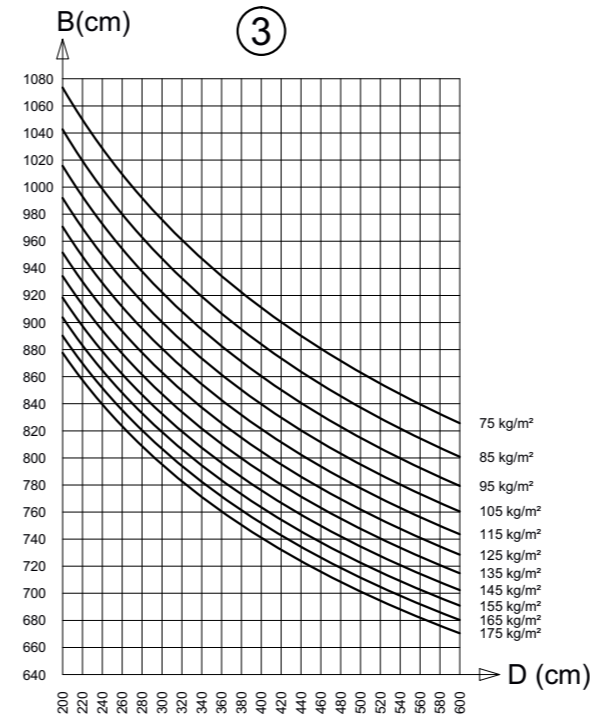
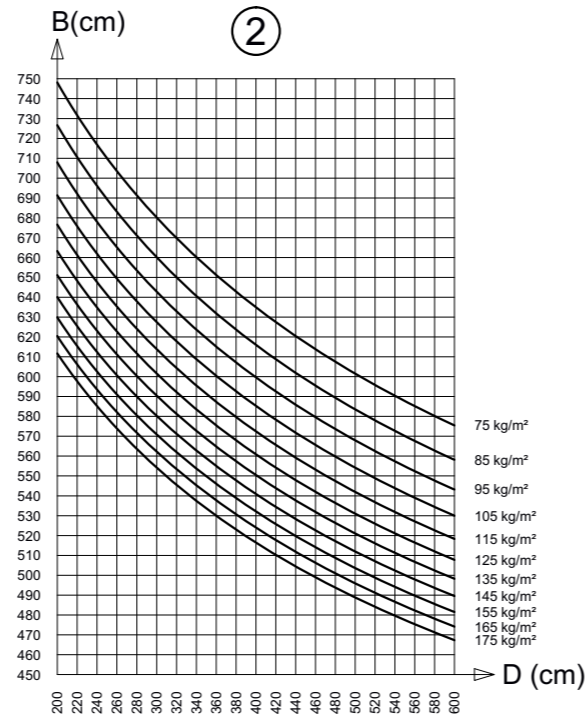
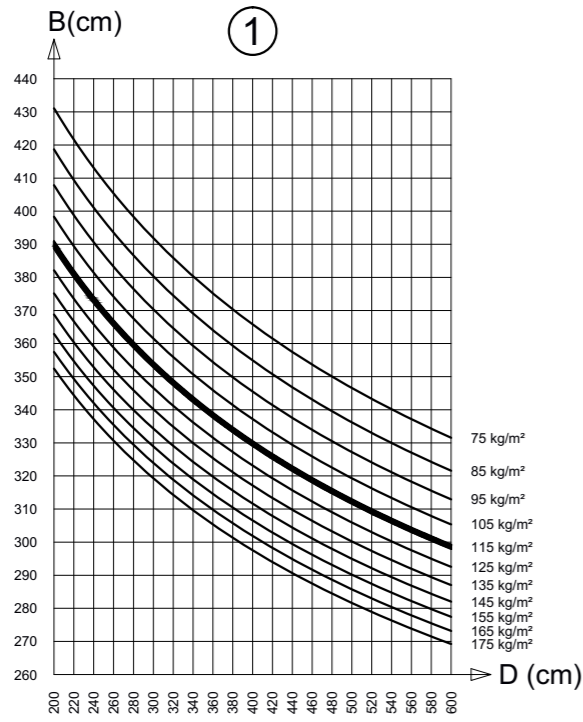

TD020  
I<sub>x</sub>: 638.5 cm<sup>4</sup>  
f<sub>max</sub>: 8 mm



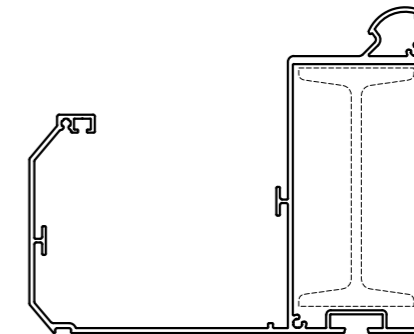
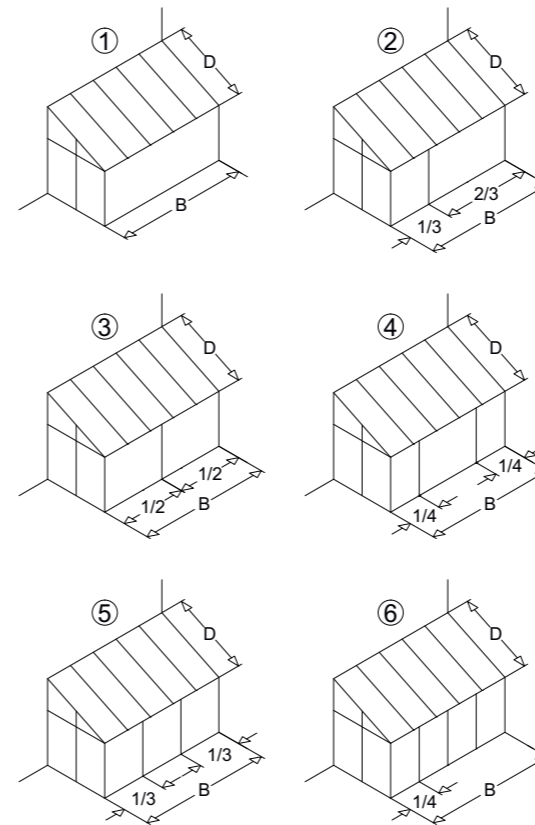
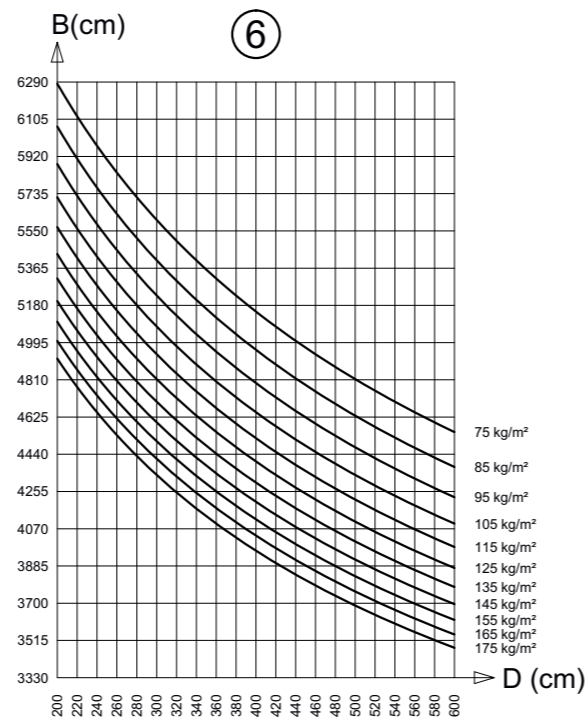
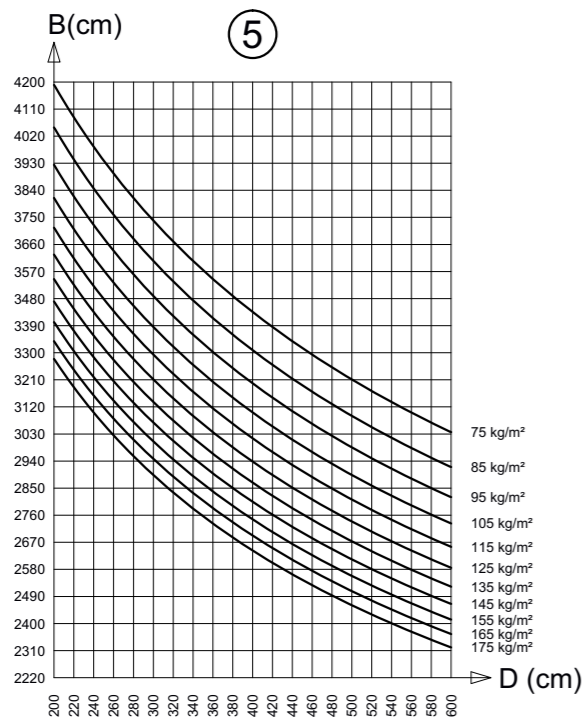
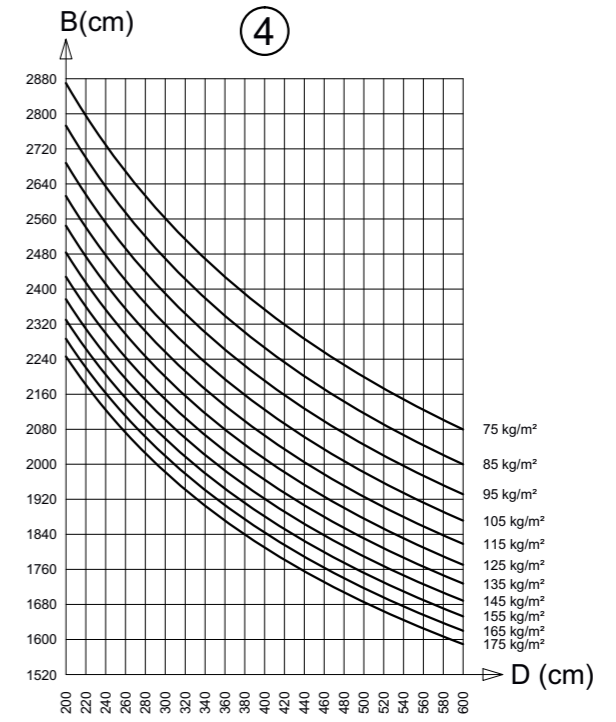
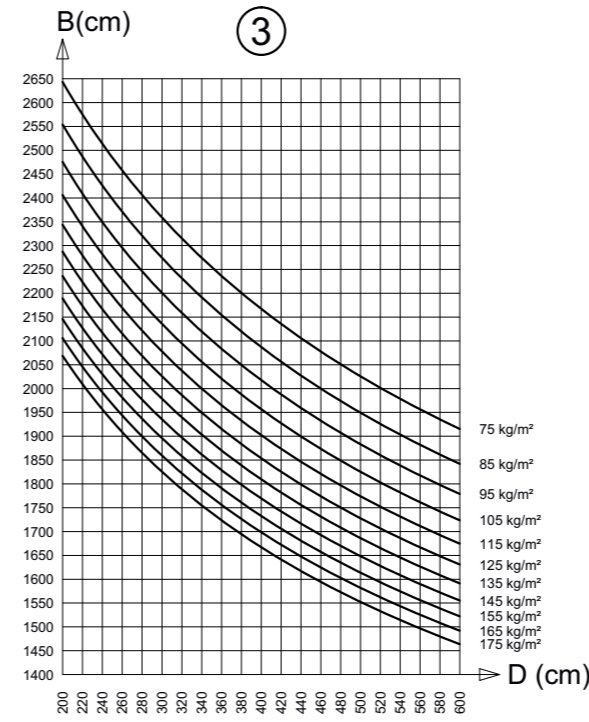
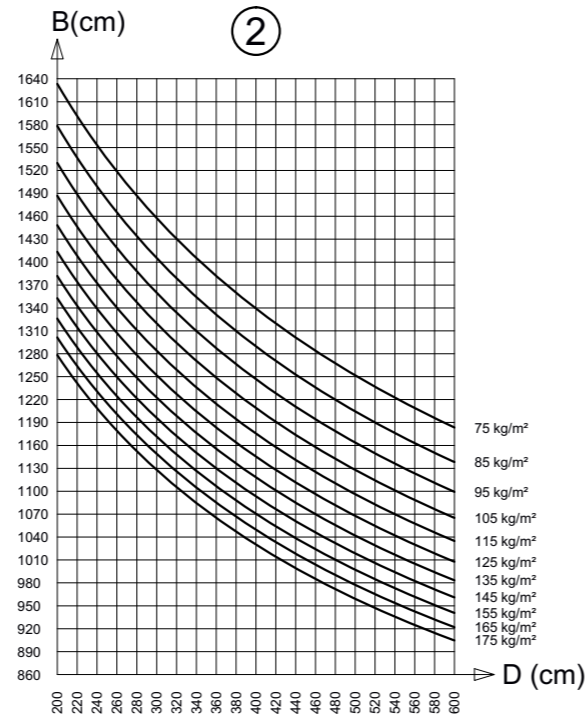
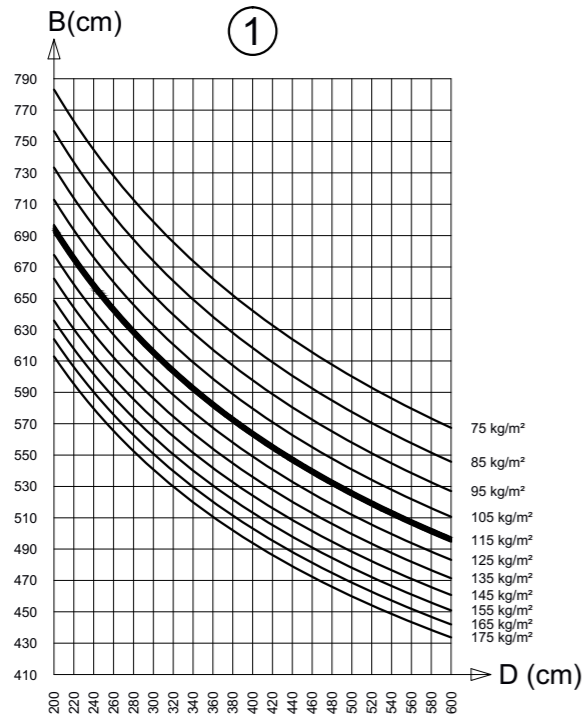

TD020 + IPN120  
I<sub>x</sub>: 1619.6 cm<sup>4</sup>  
f<sub>max</sub>: L/200

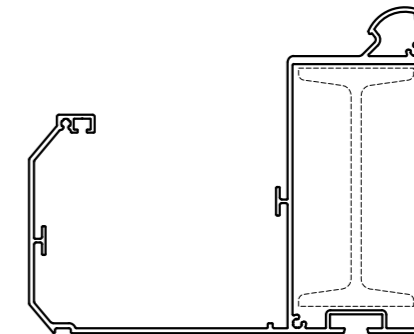
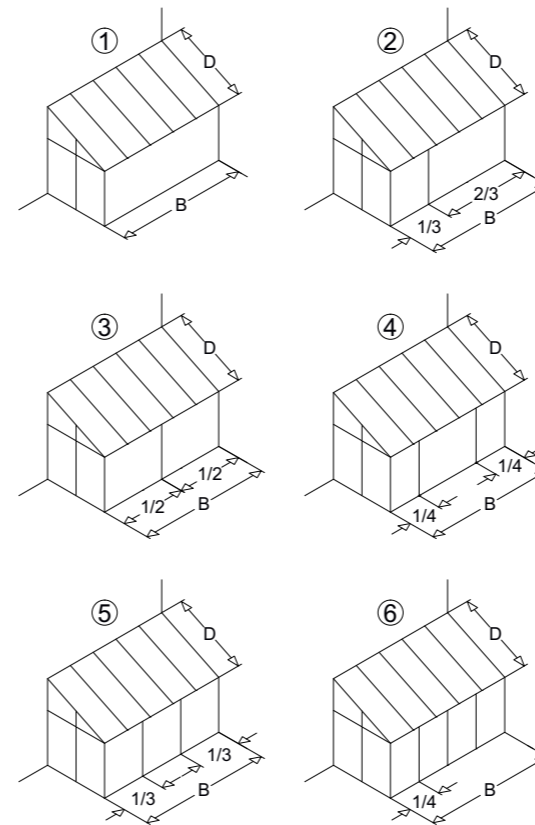
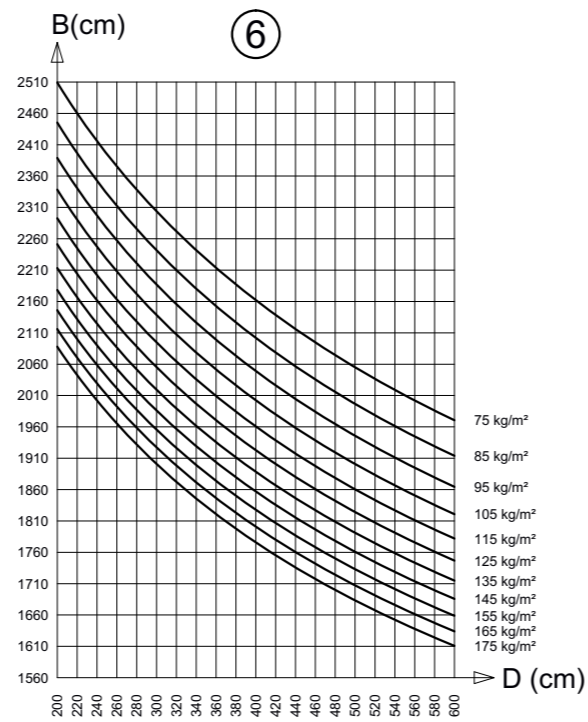
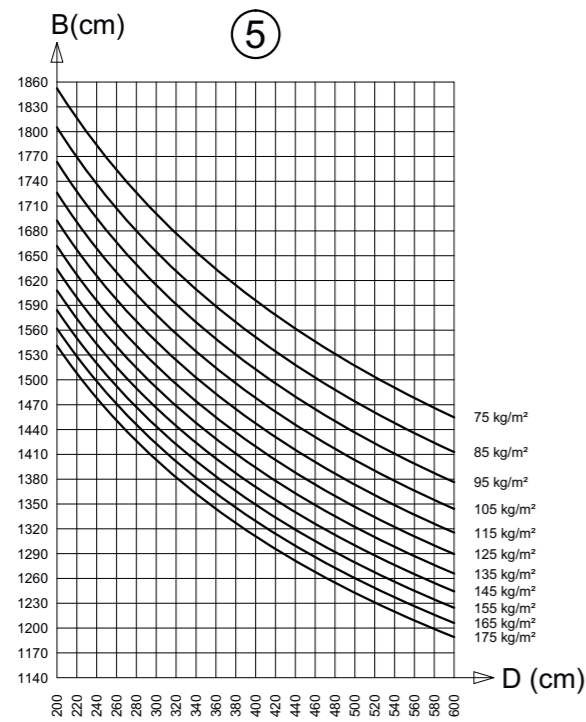
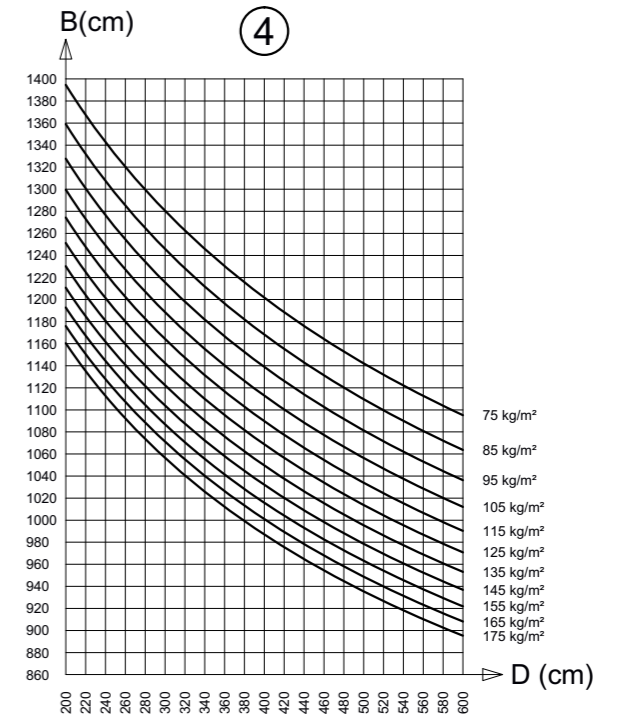
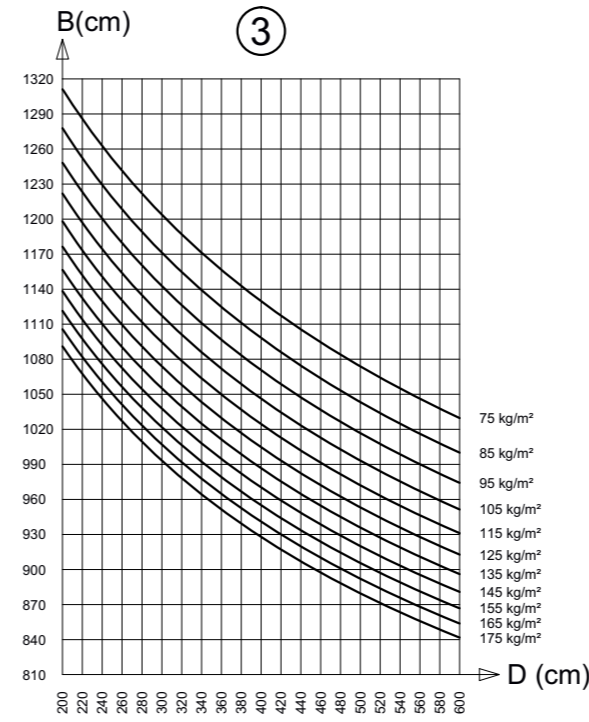
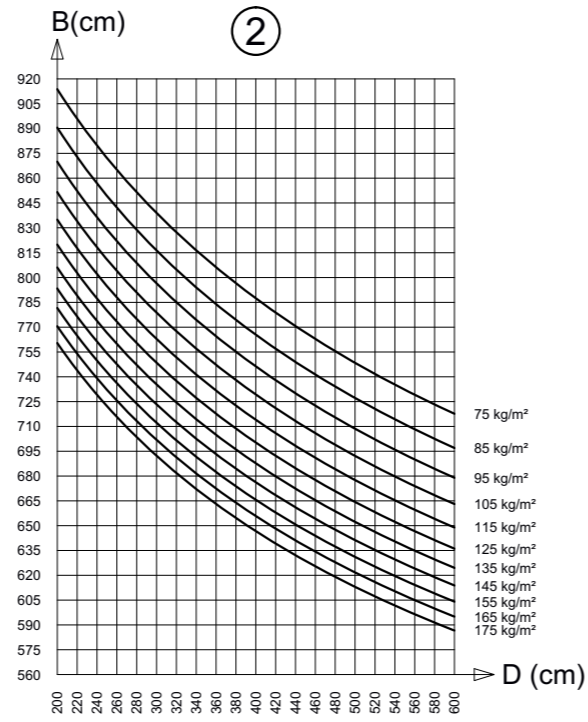
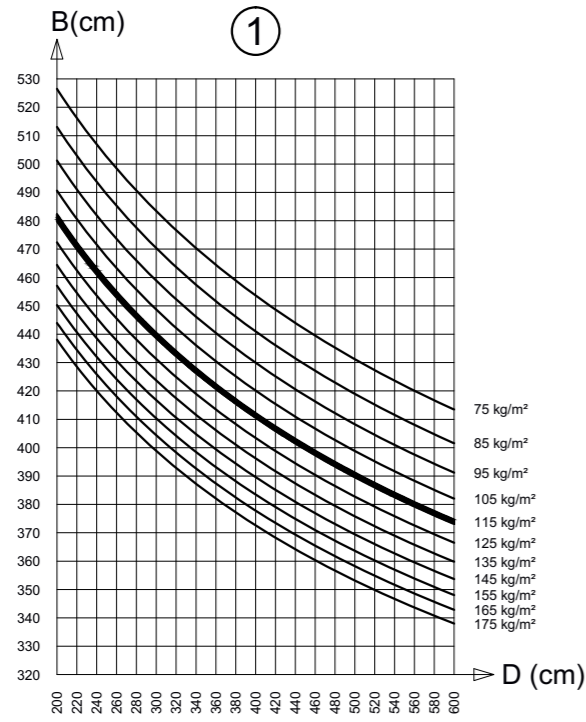

**TD020 + IPN120**  
**lx: 1619.6 cm4**  
**fmax: 8 mm**

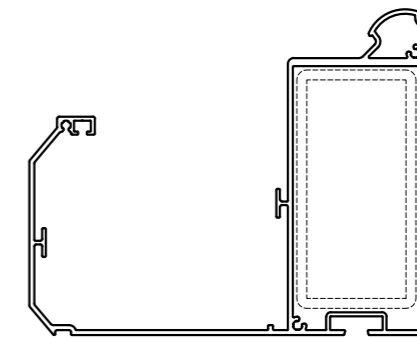
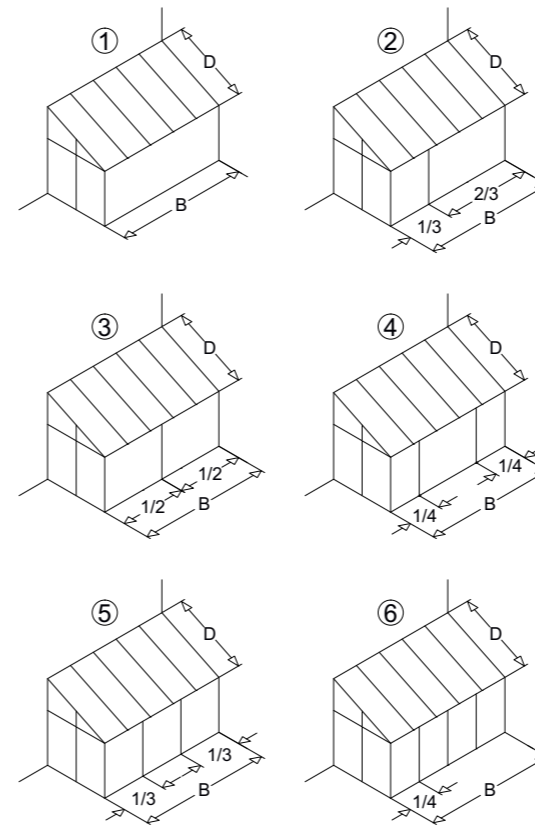
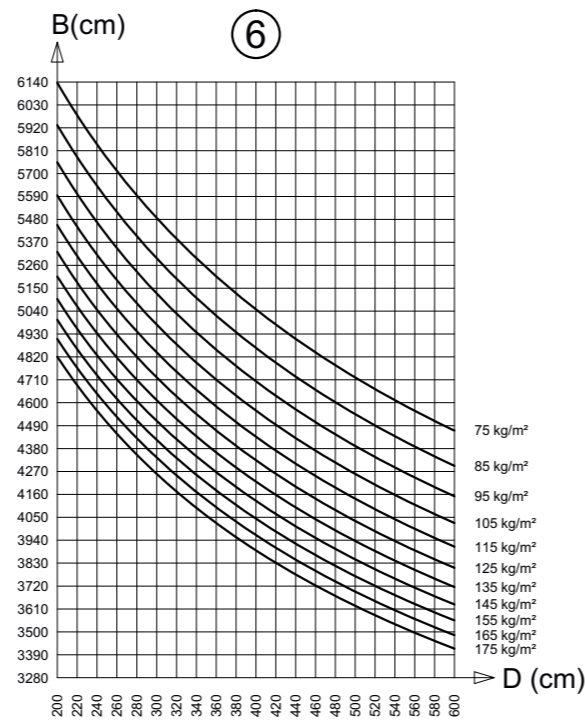
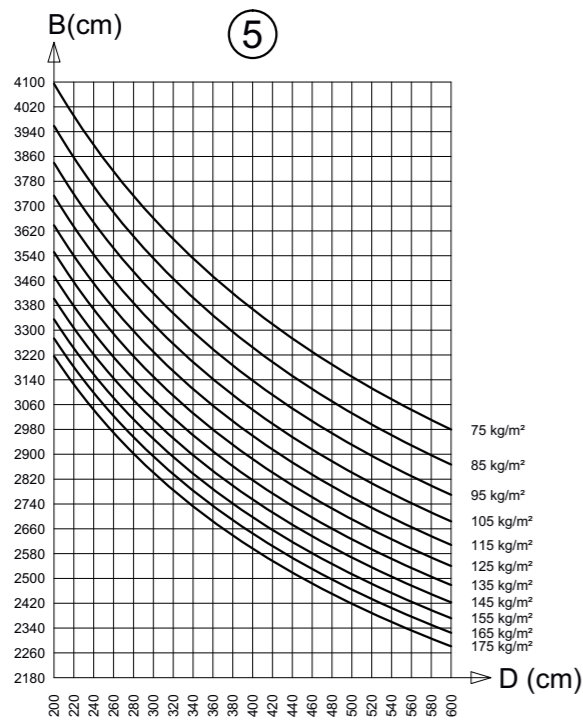
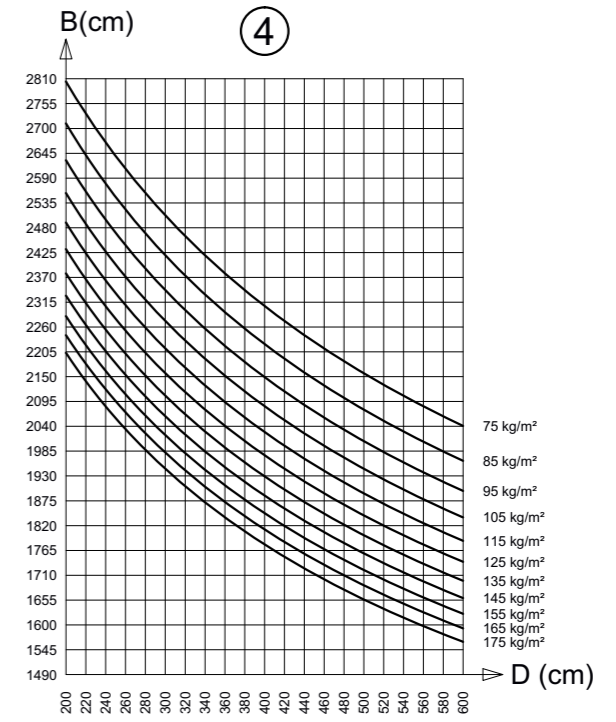
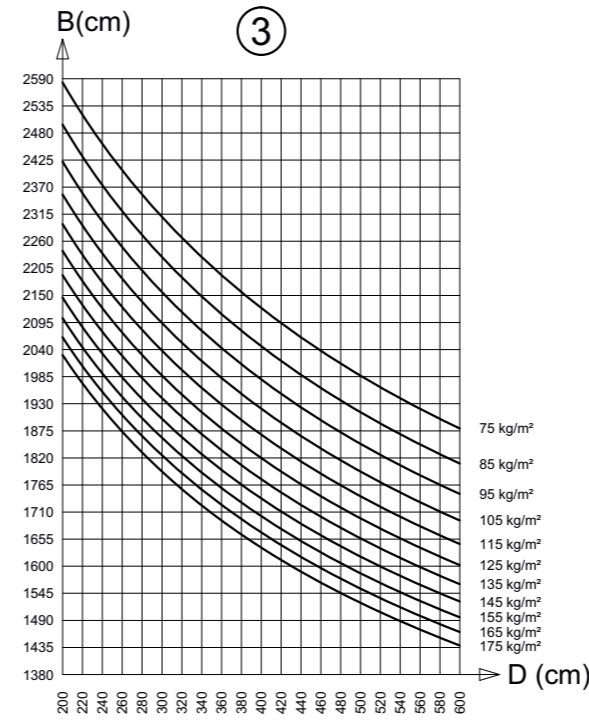
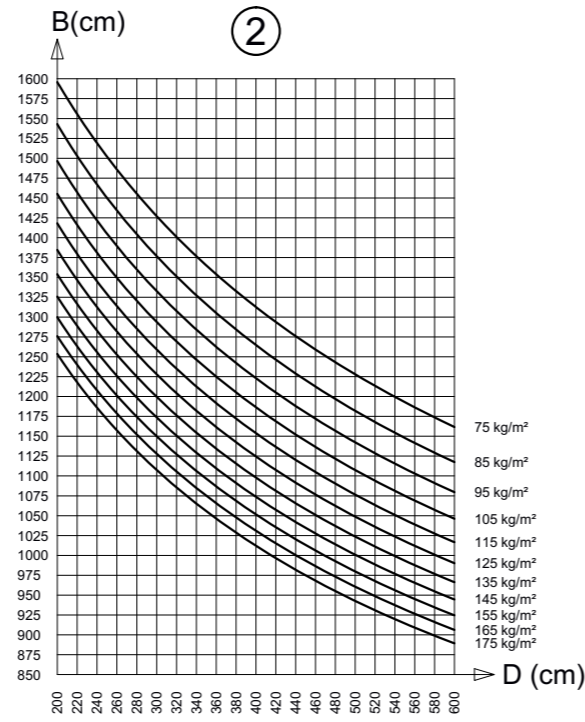
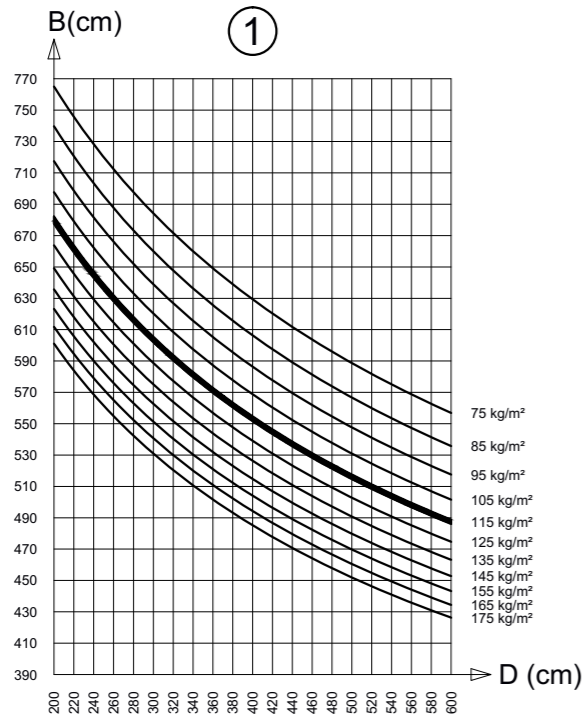

TD020 + R120x60x5 (Fe) VR6161  
I<sub>x</sub>: 1544.4 cm<sup>4</sup>  
f<sub>max</sub>: L/200

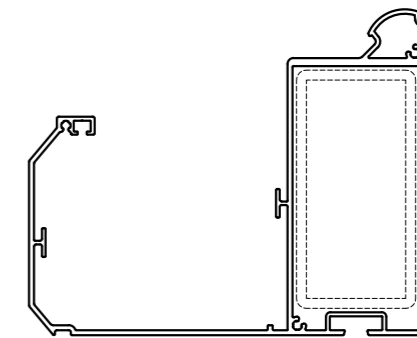
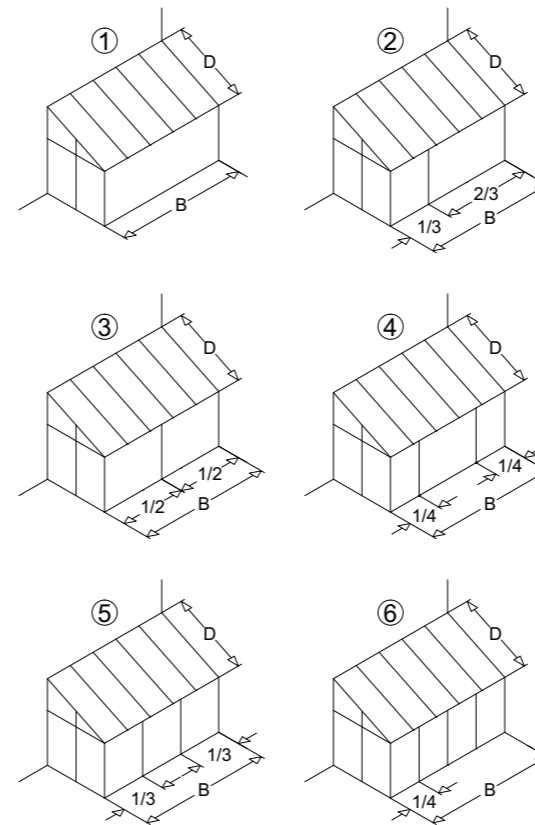
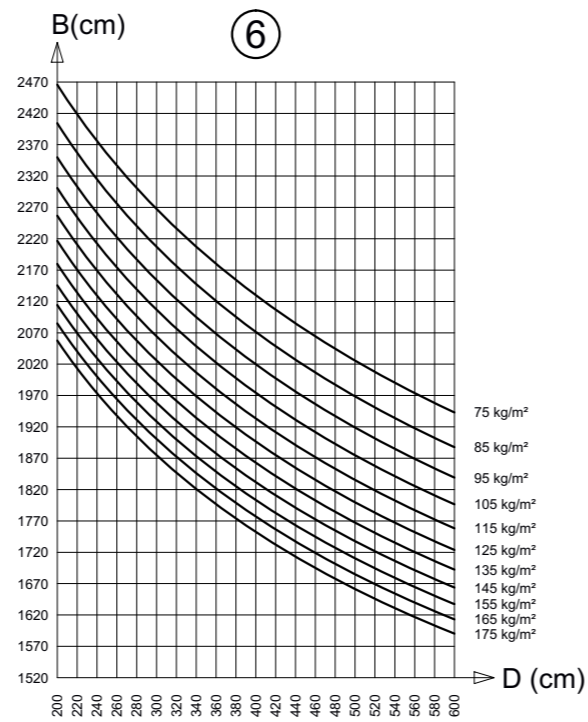
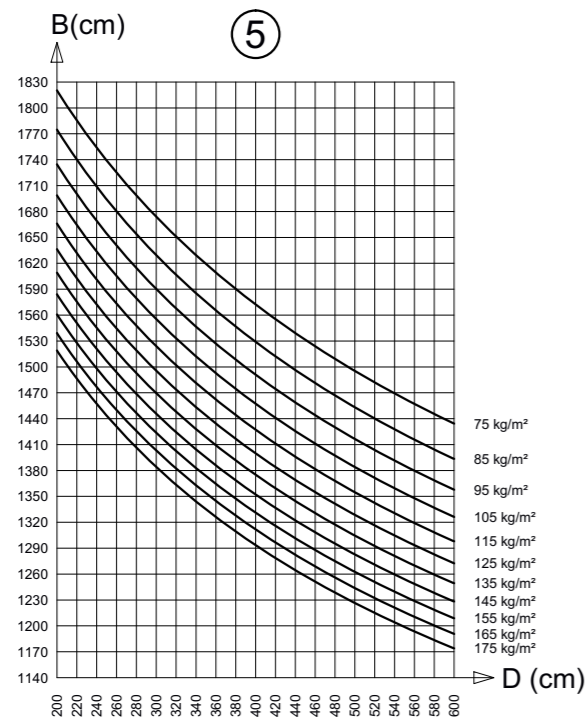
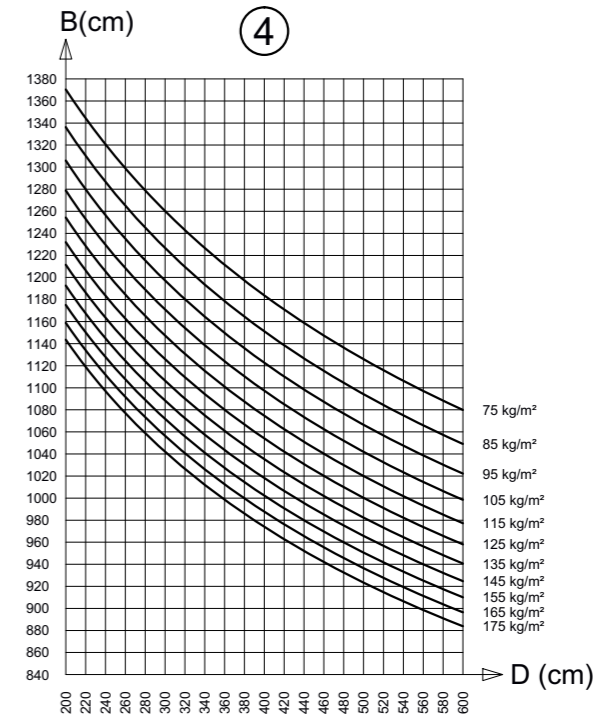
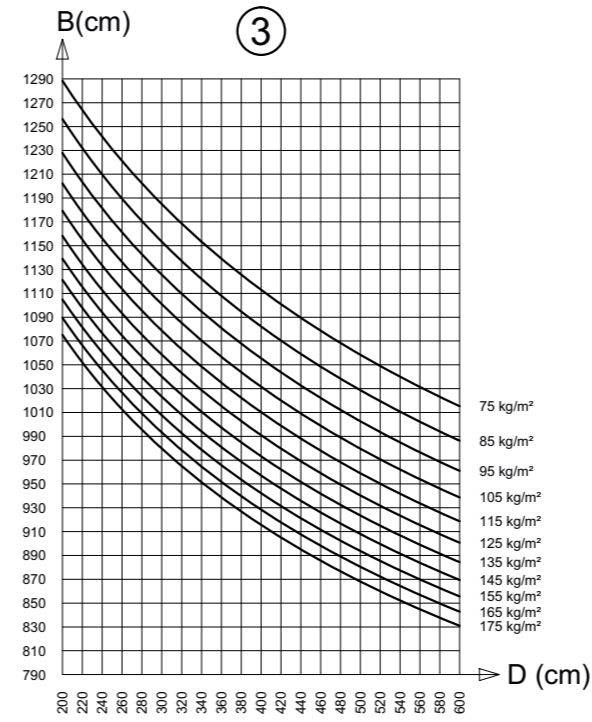
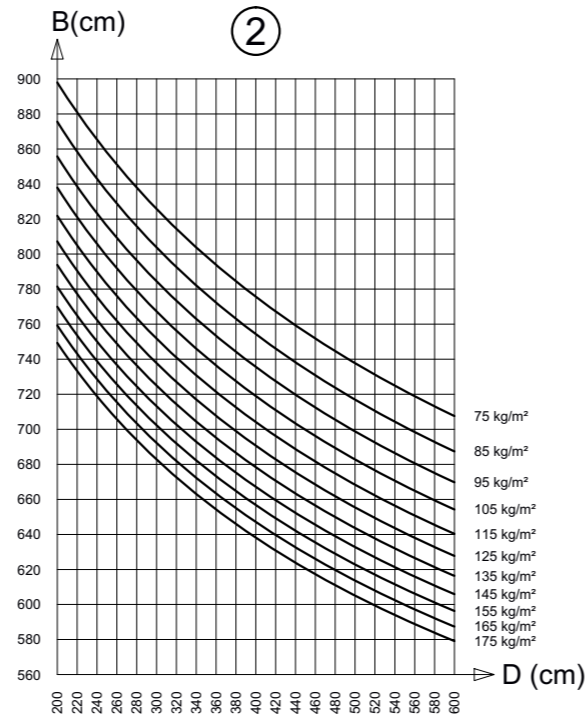
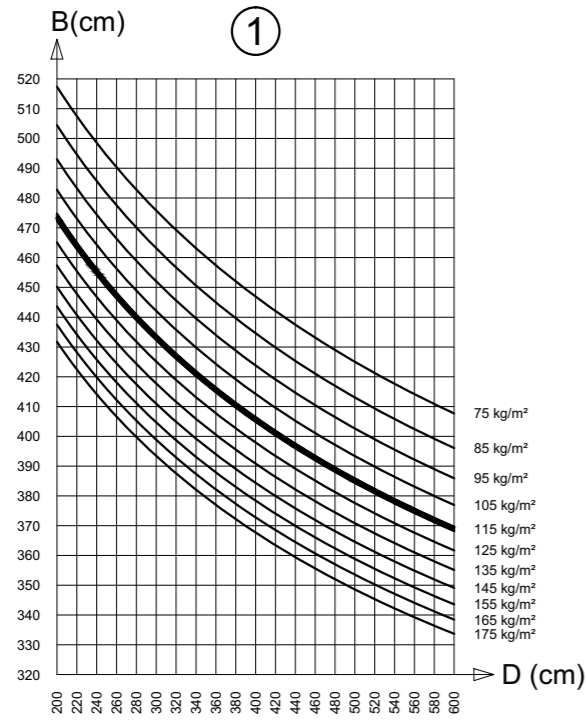

TD020 + R120x60x5 (Fe) VR6161  
 lx: 1544.4 cm4  
 fmax: 8mm

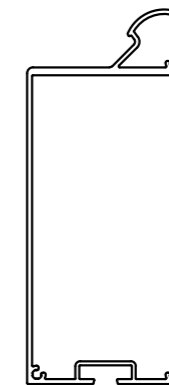
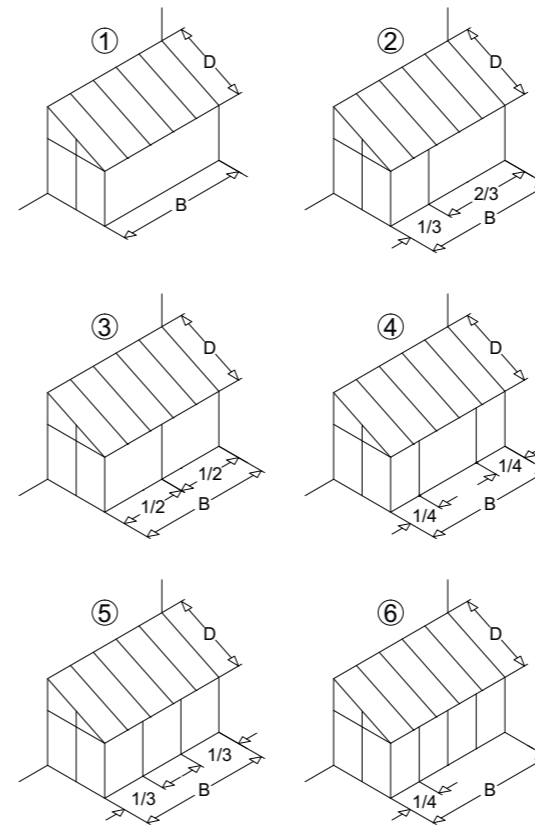
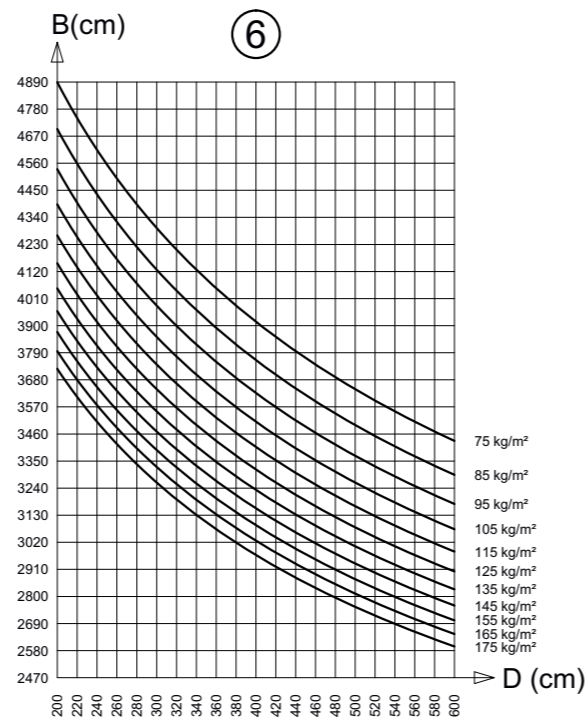
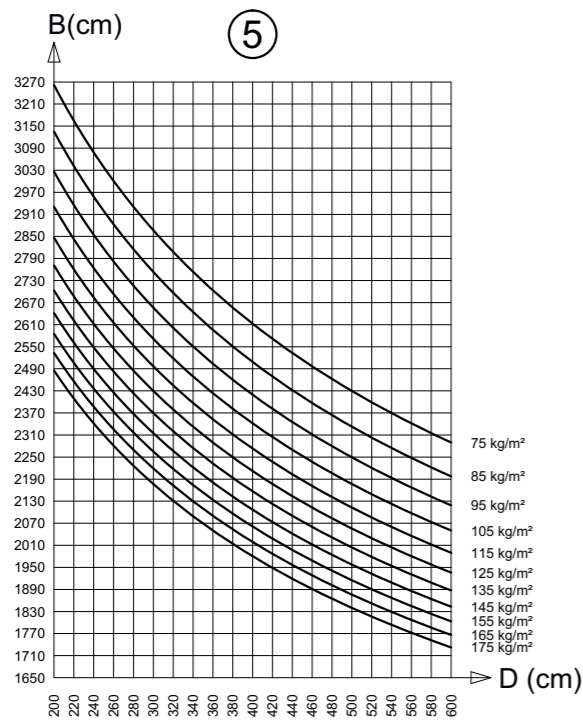
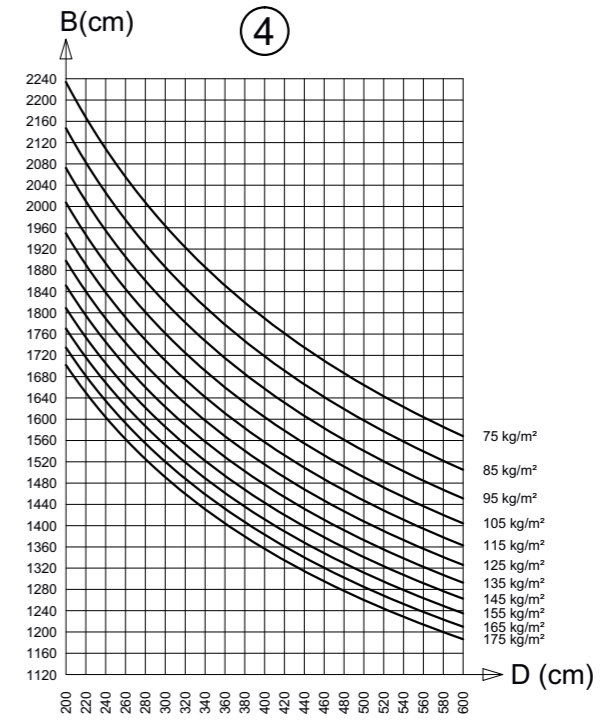
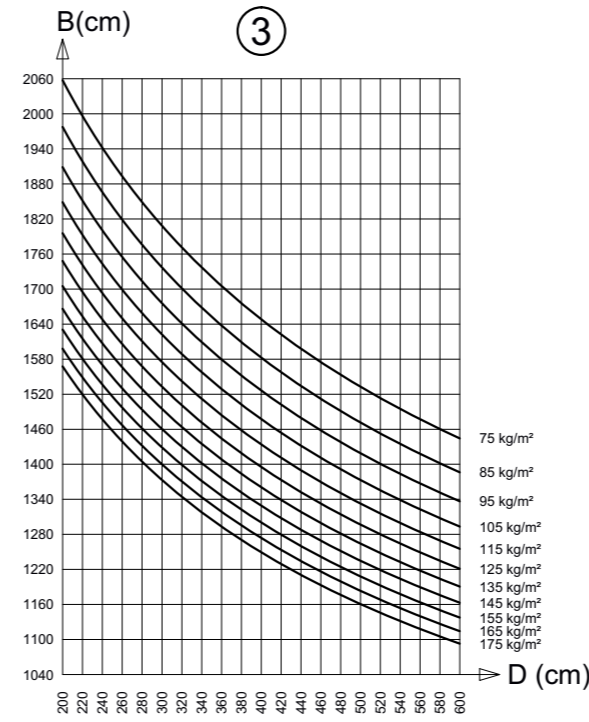
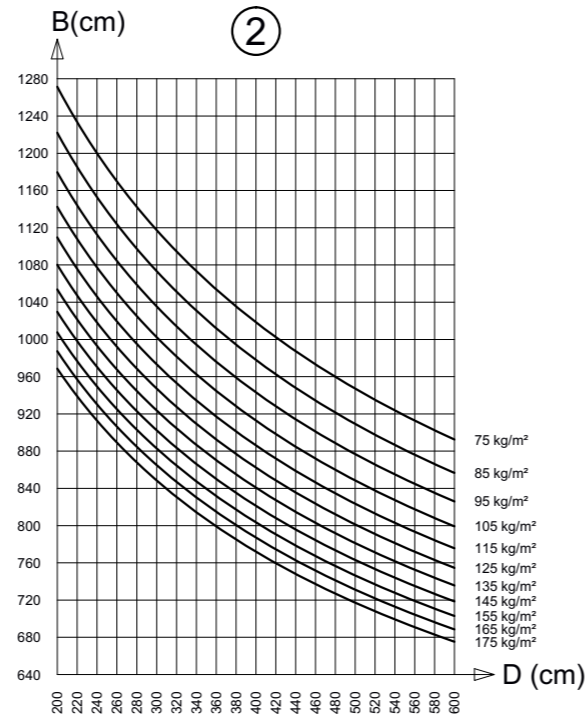
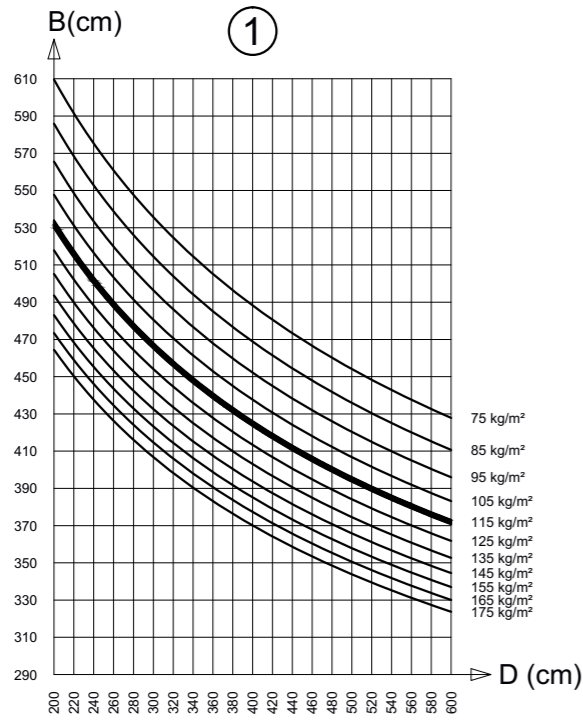

TD021  
Ix: 657.9 cm<sup>4</sup>  
fmax: L/200

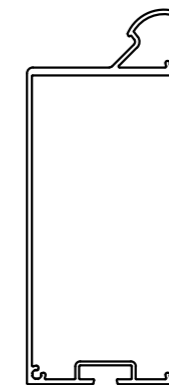
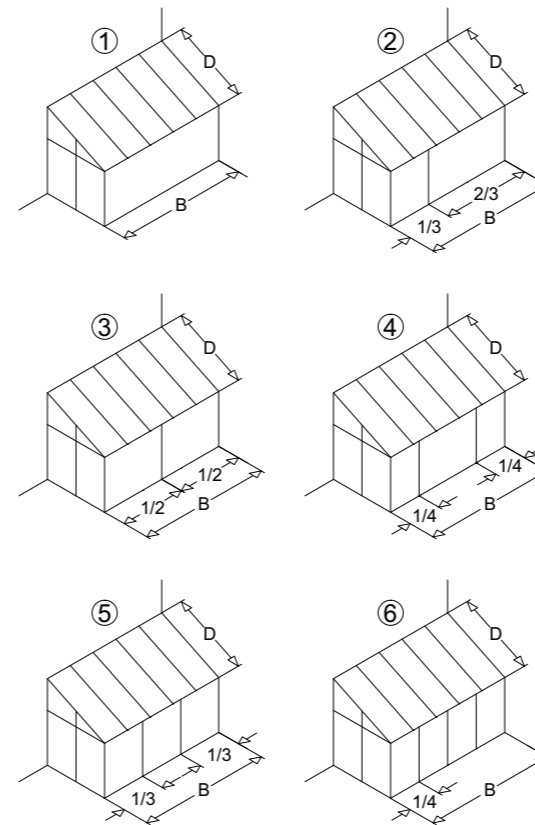
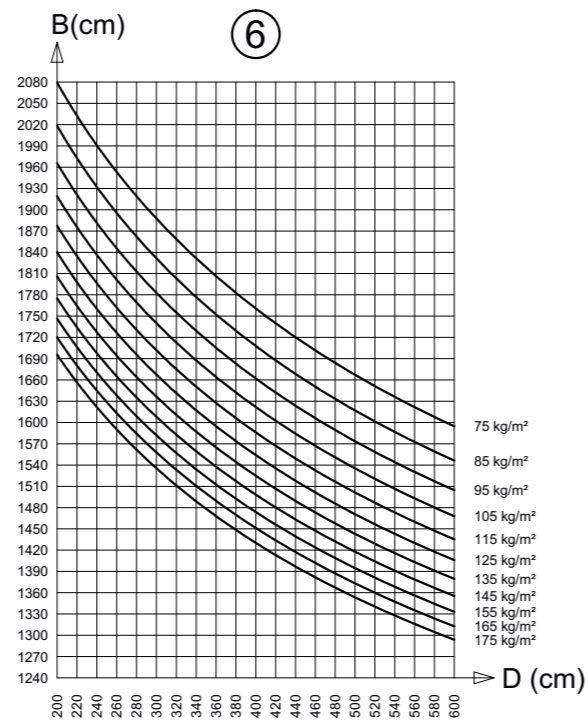
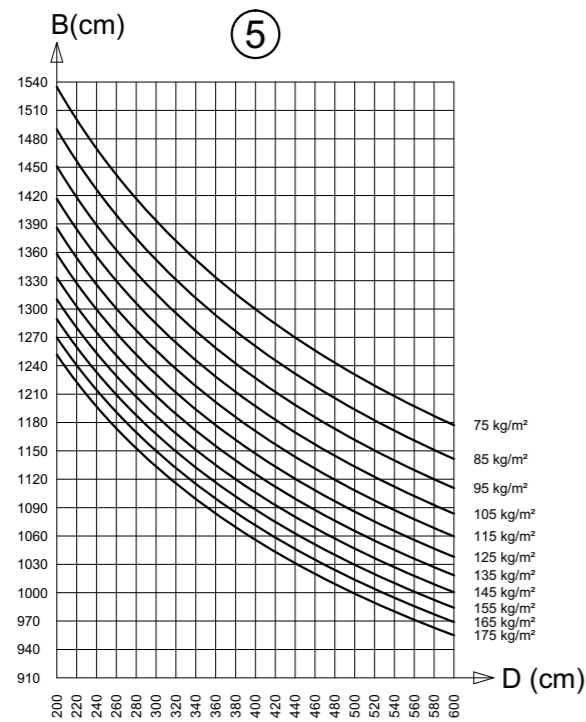
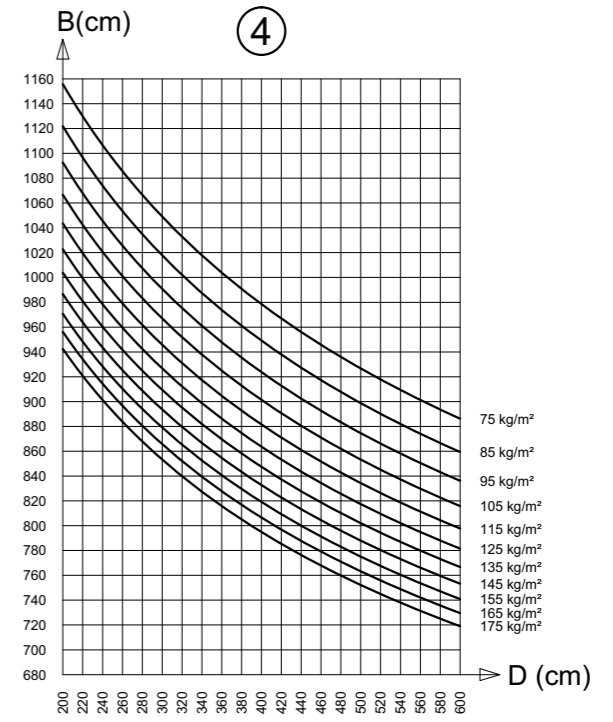
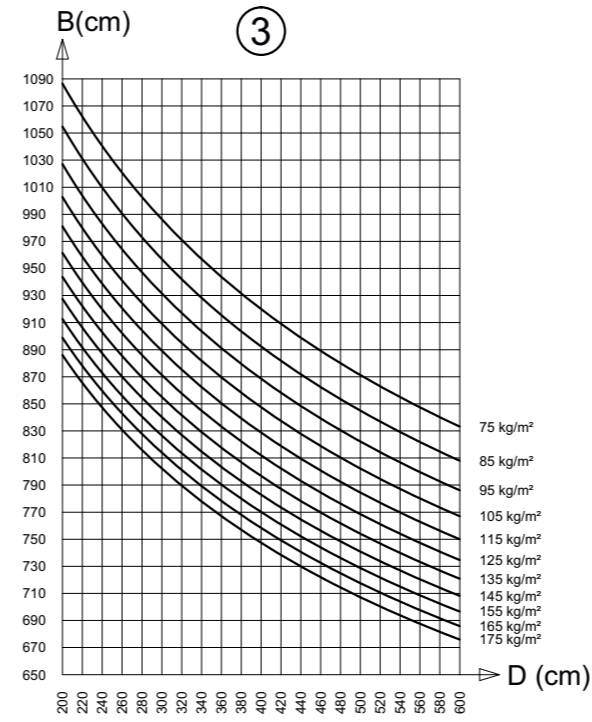
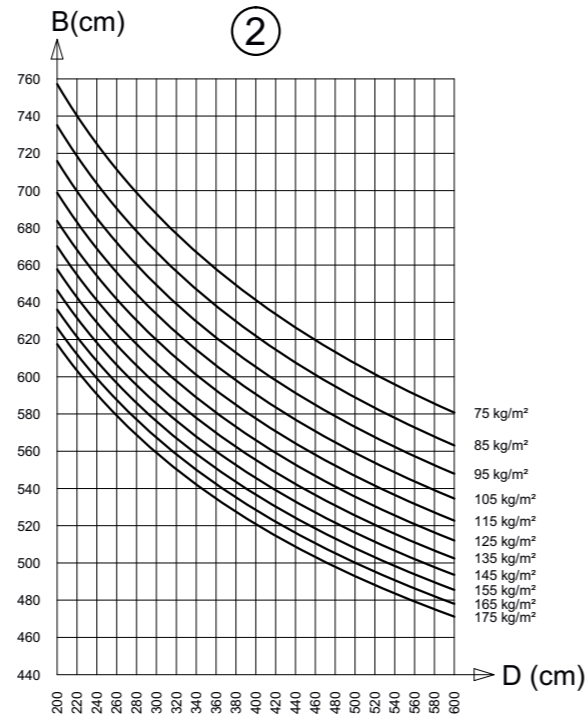
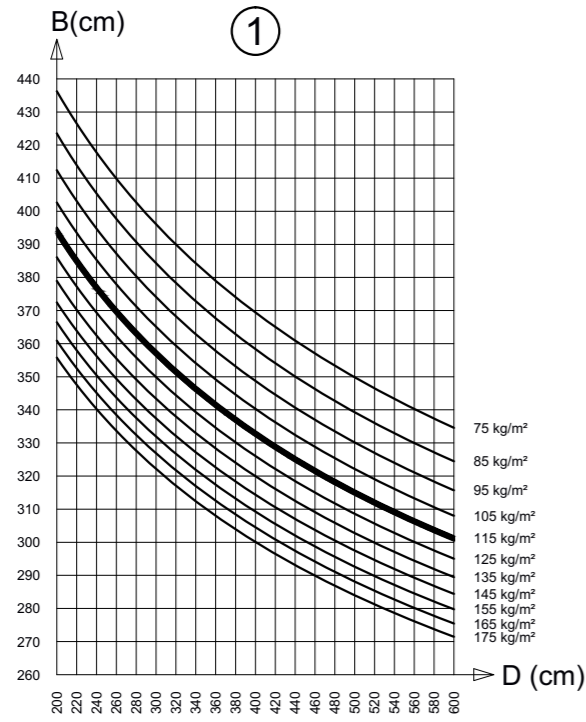

**TD021**  
 Ix: 657.9 cm<sup>4</sup>  
 fmax: 8 mm

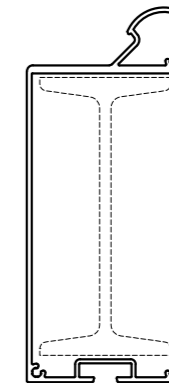
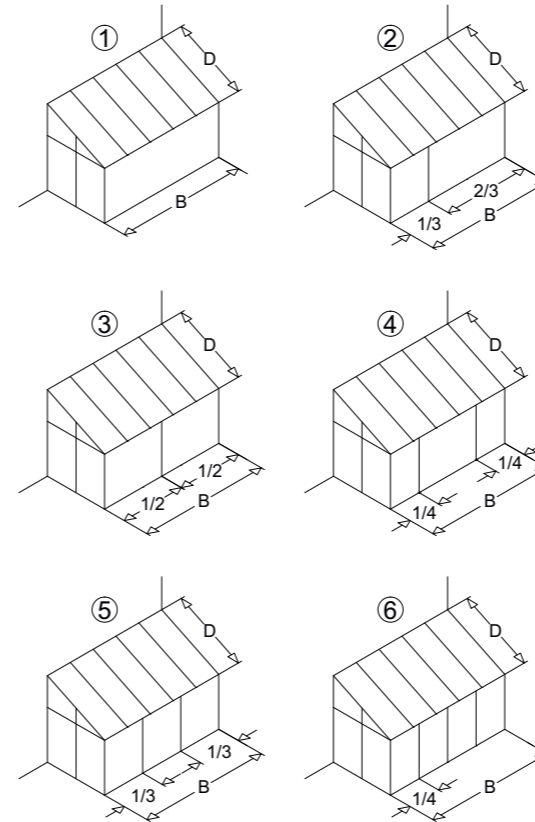
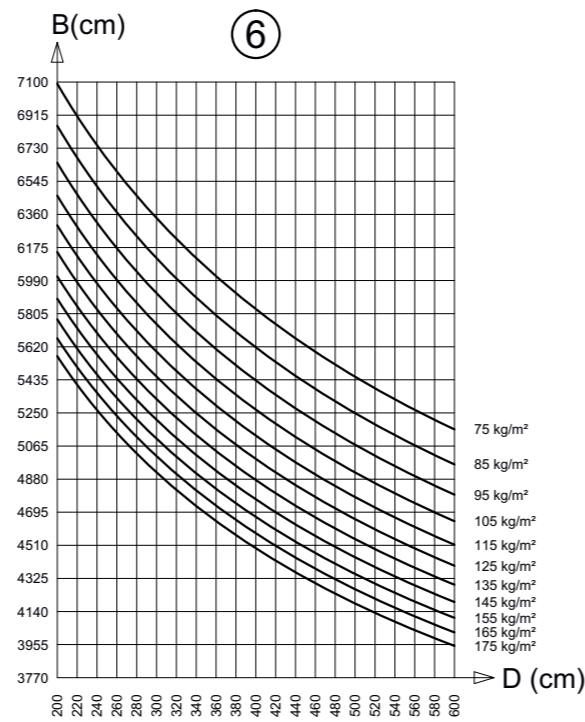
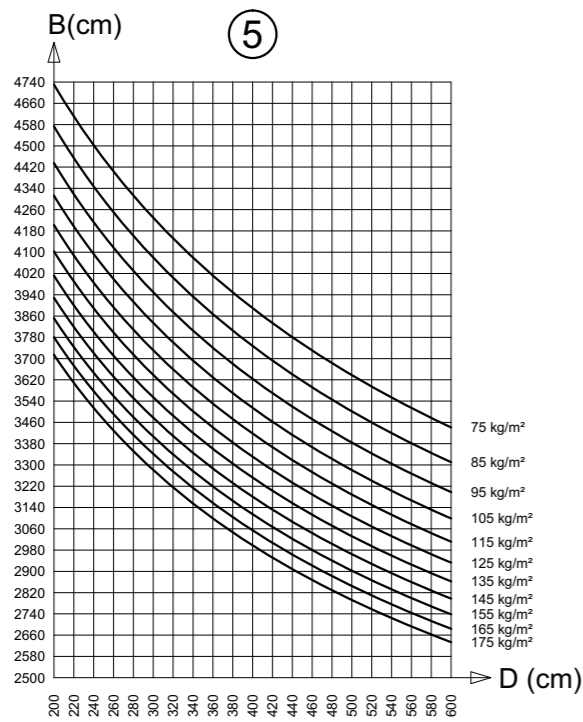
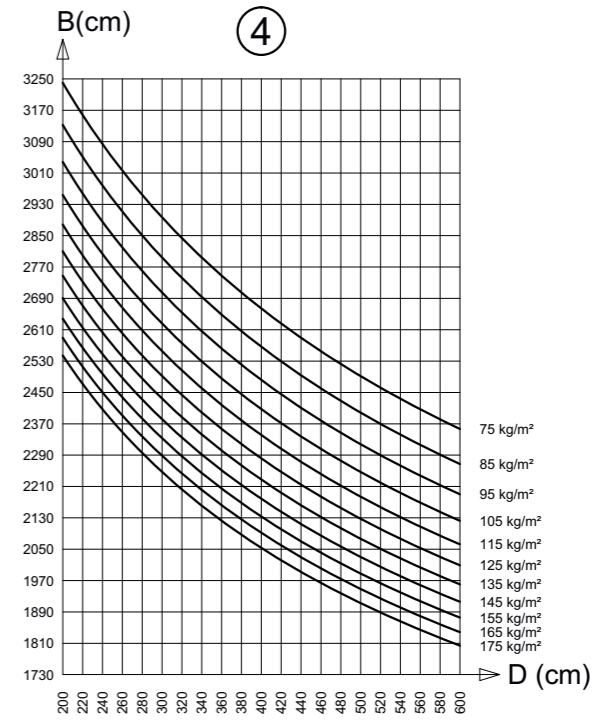
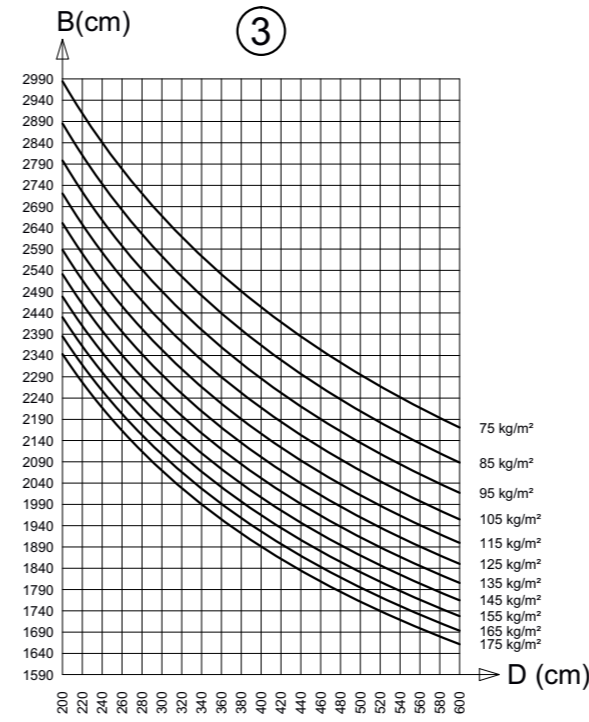
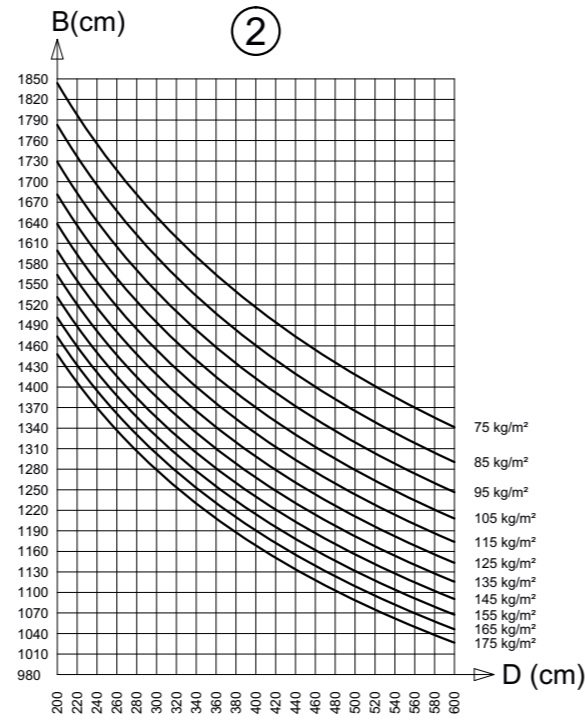
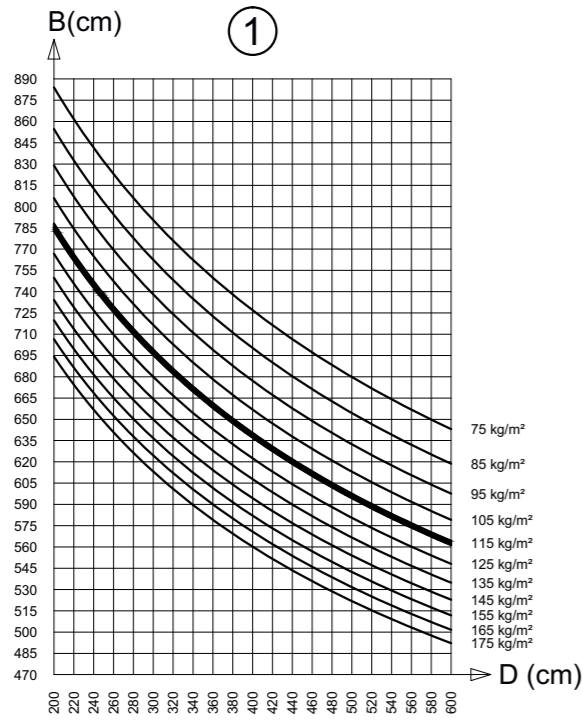

TD021 + IPN140  
Ix: 2375.5 cm<sup>4</sup>  
fmax: L/200

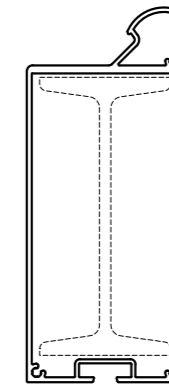
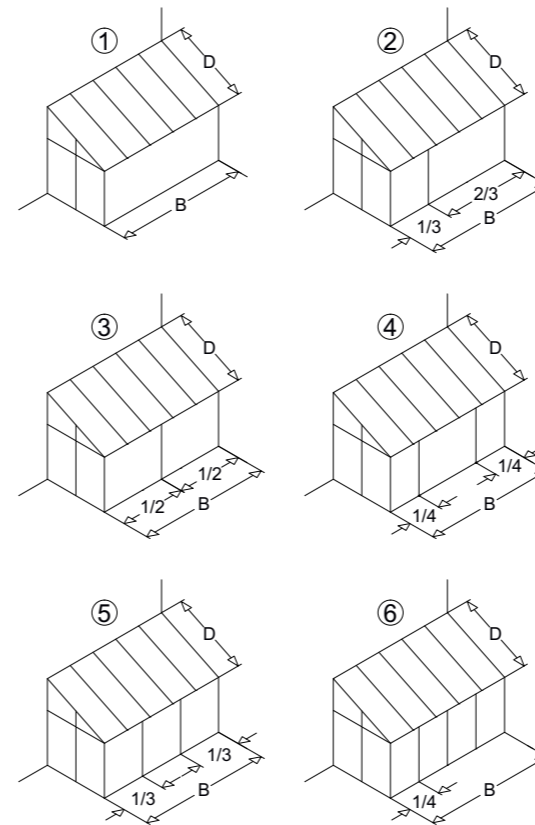
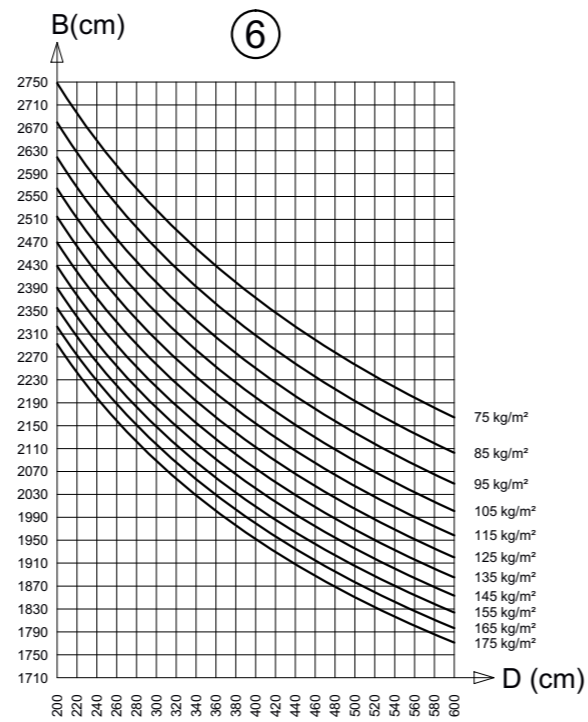
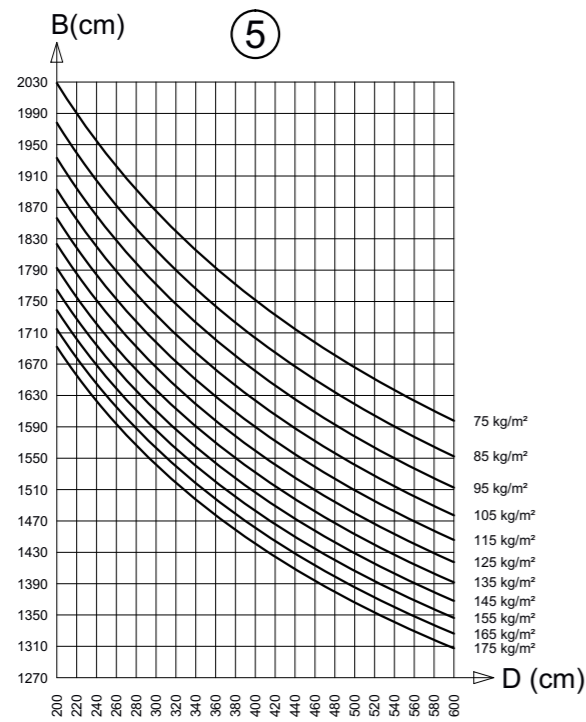
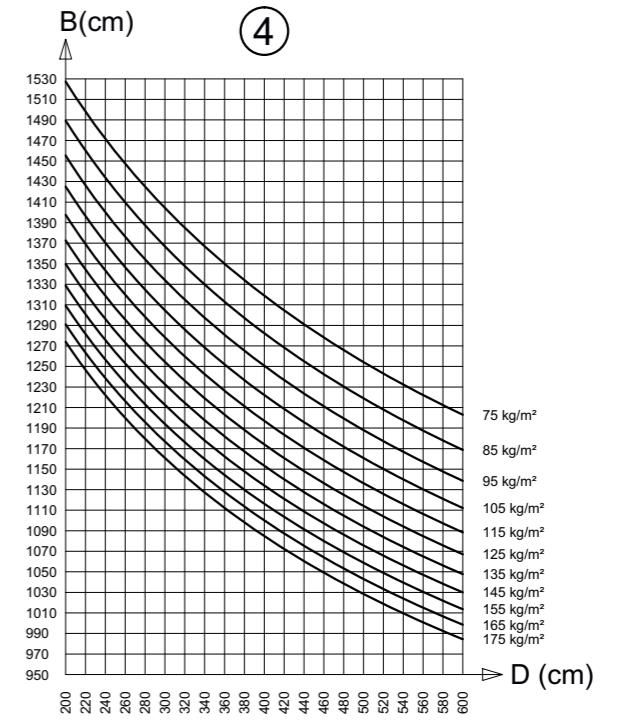
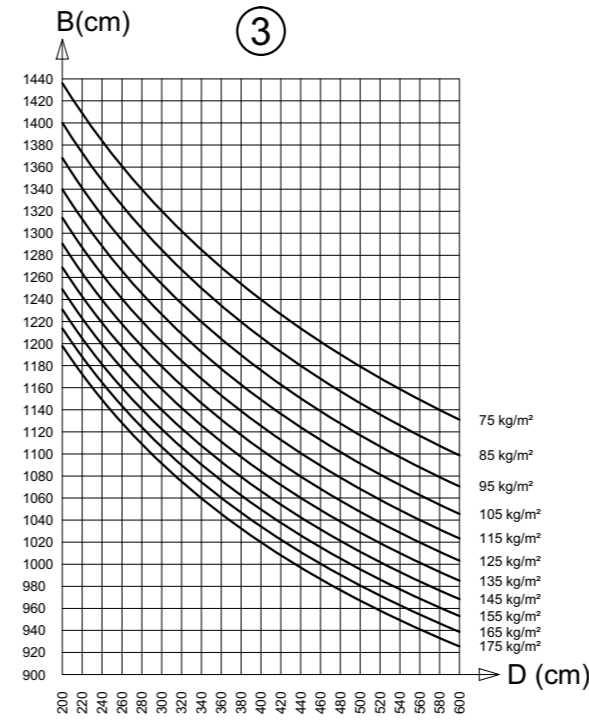
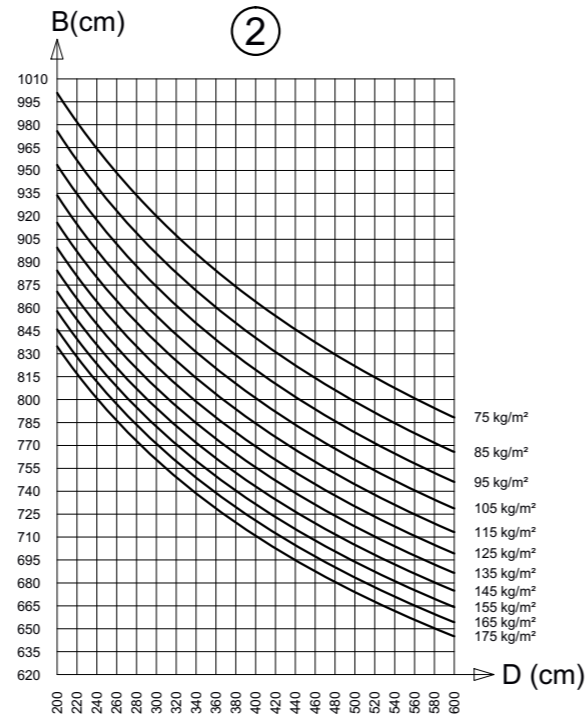
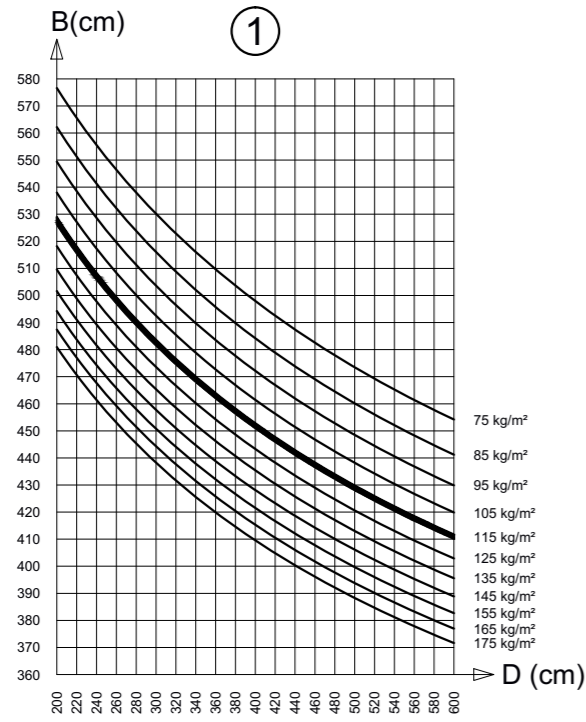

TD021 + IPN140  
 Ix: 2375.5 cm<sup>4</sup>  
 fmax: 8 mm



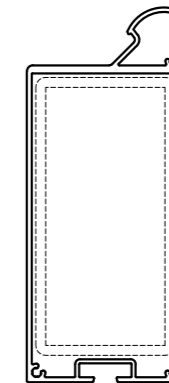
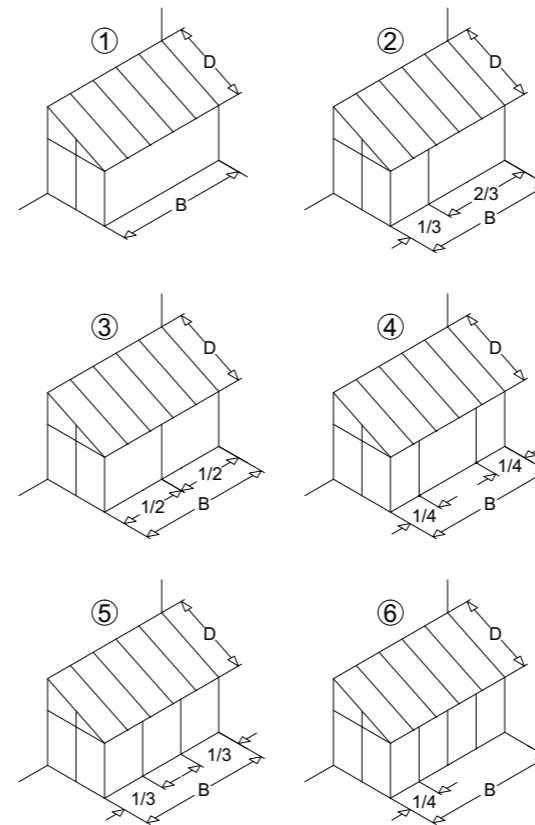
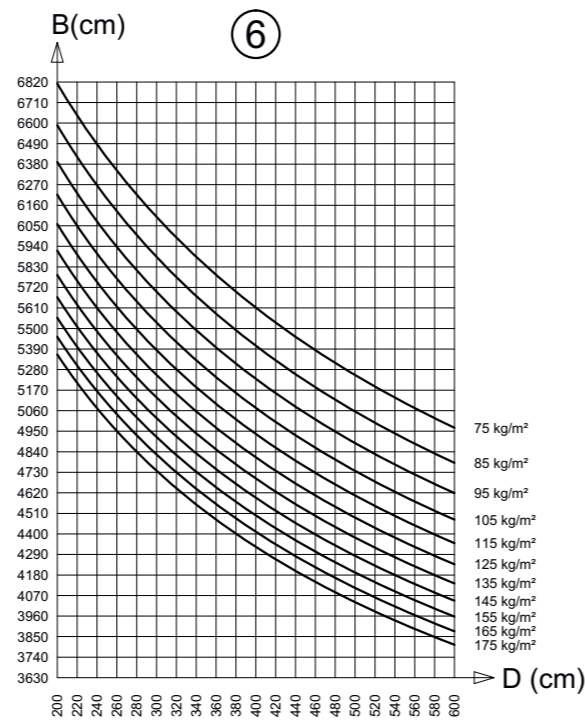
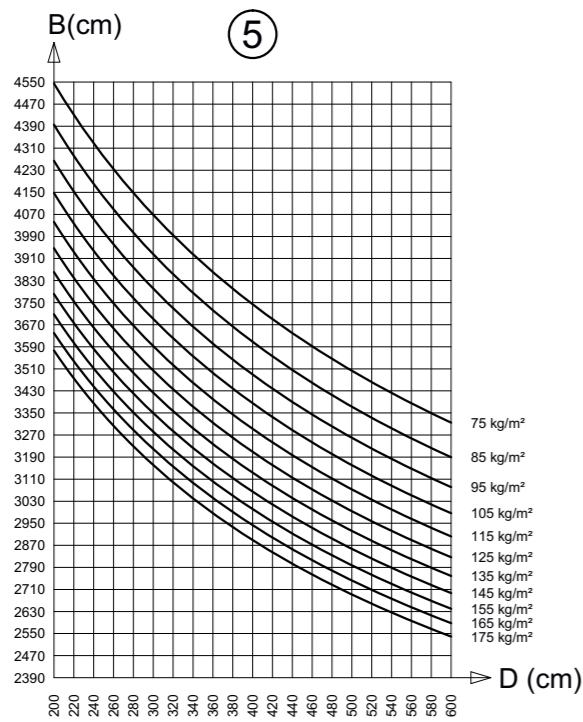
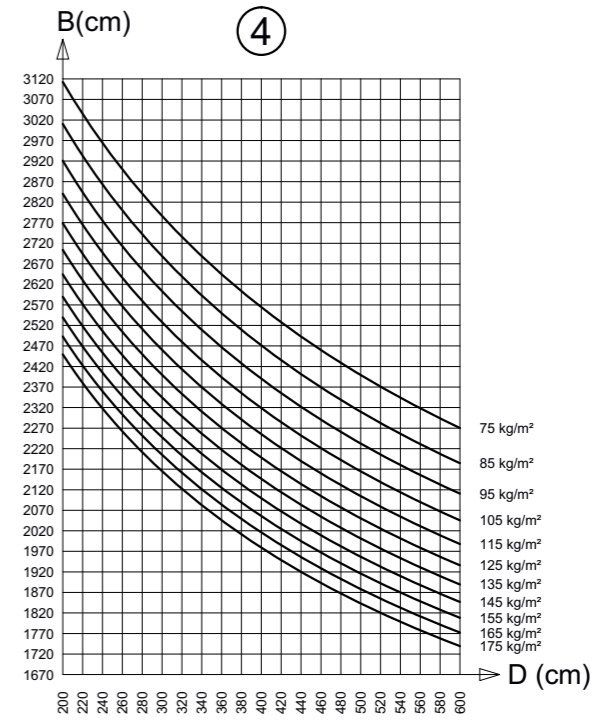
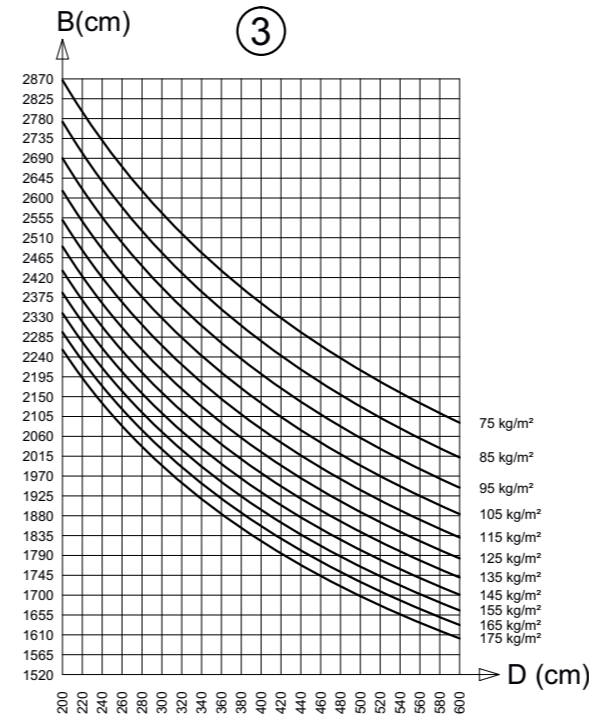
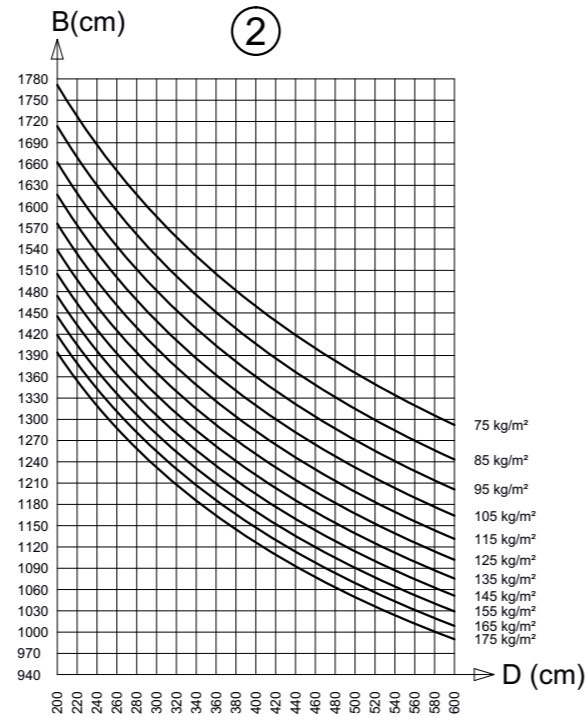
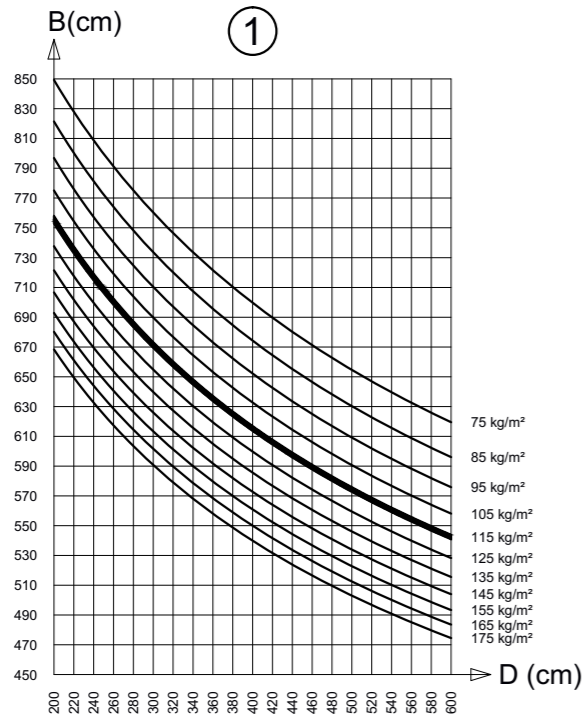

TD021 + R140x70x5 (Fe)  
Ix: 2133.9 cm<sup>4</sup>  
fmax: L/200

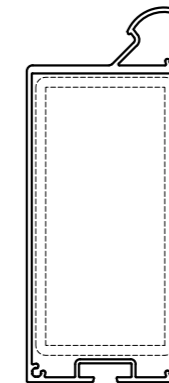
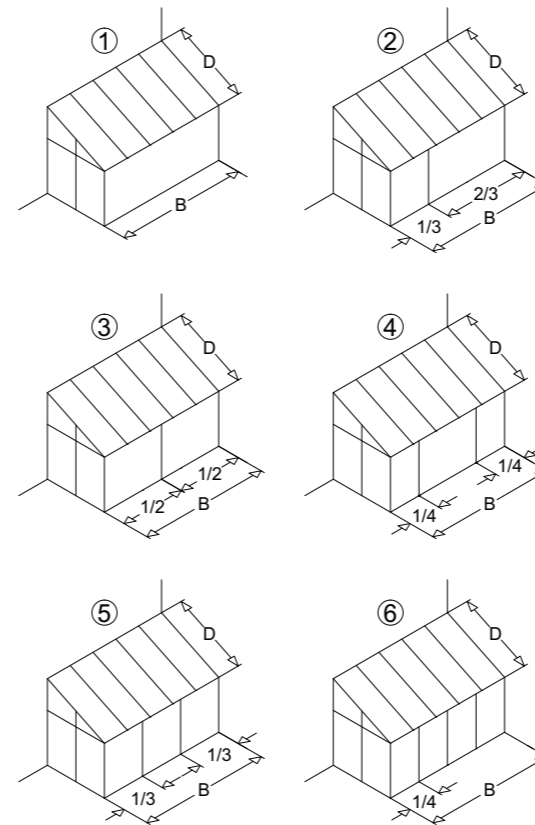
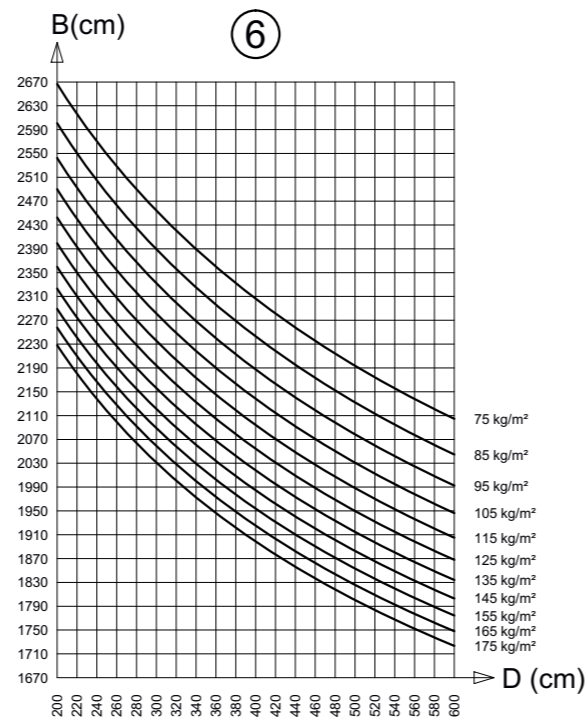
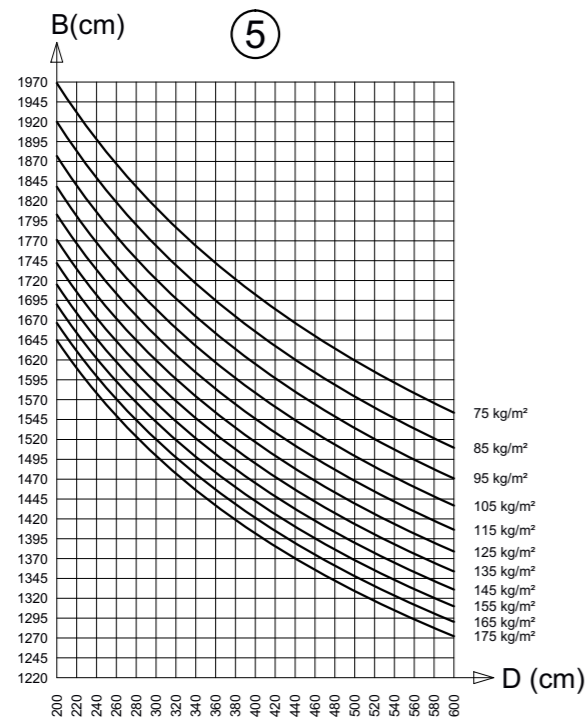
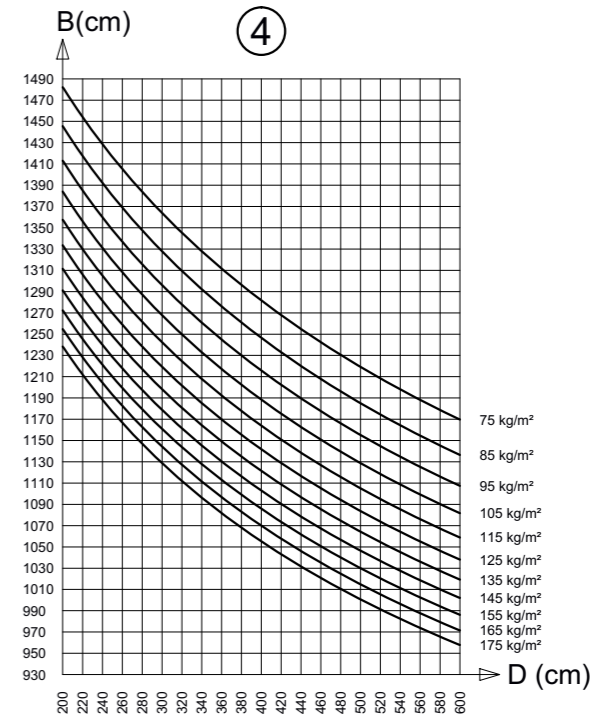
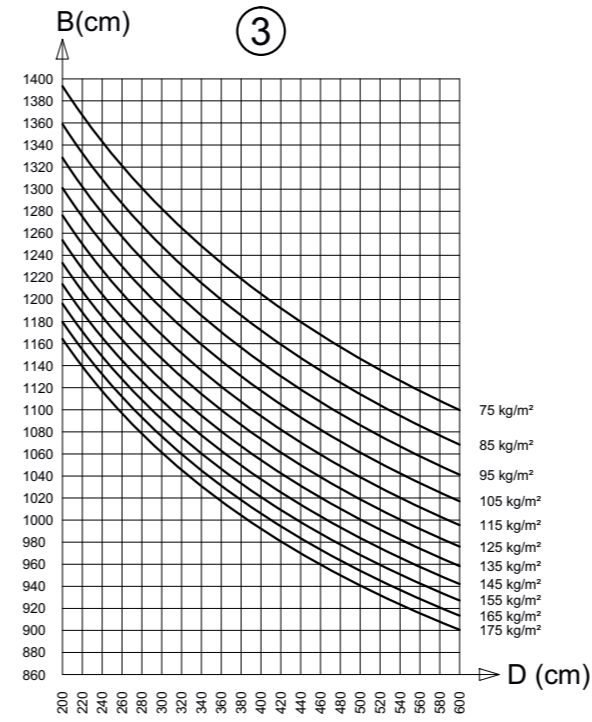
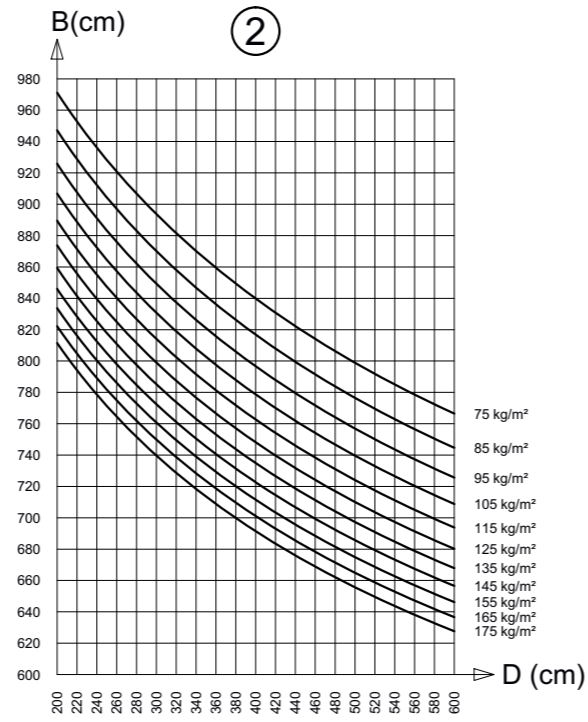
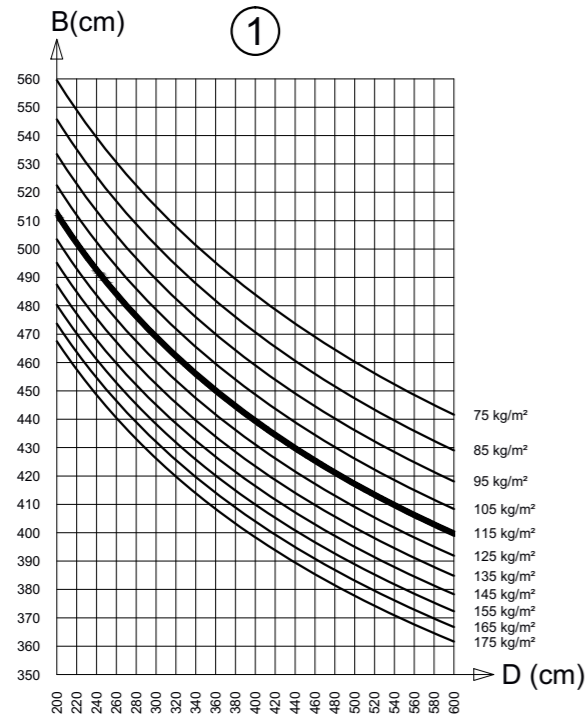

**TD021 + R140x70x5 (Fe)**  
 Ix: 2133.9 cm<sup>4</sup>  
 fmax: 8 mm

⚠ Min. 5° < Max. 25°

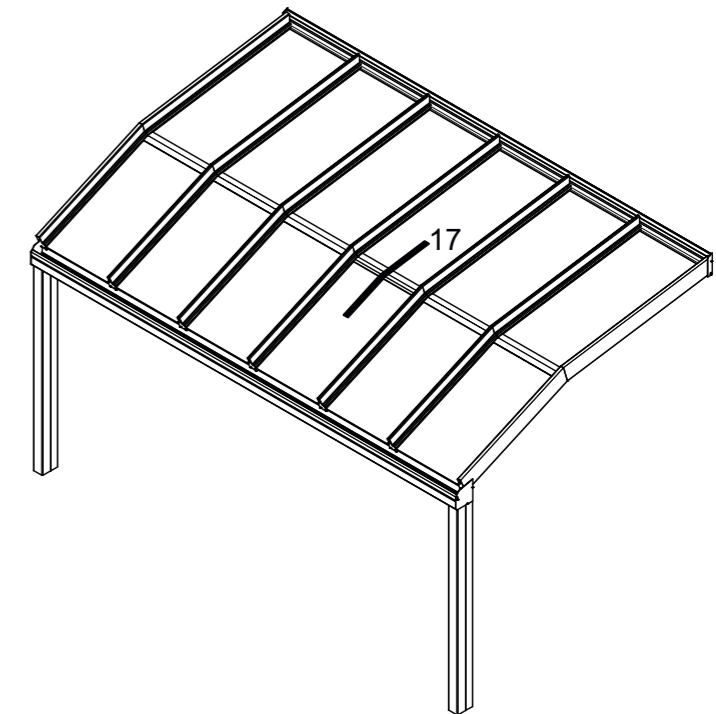
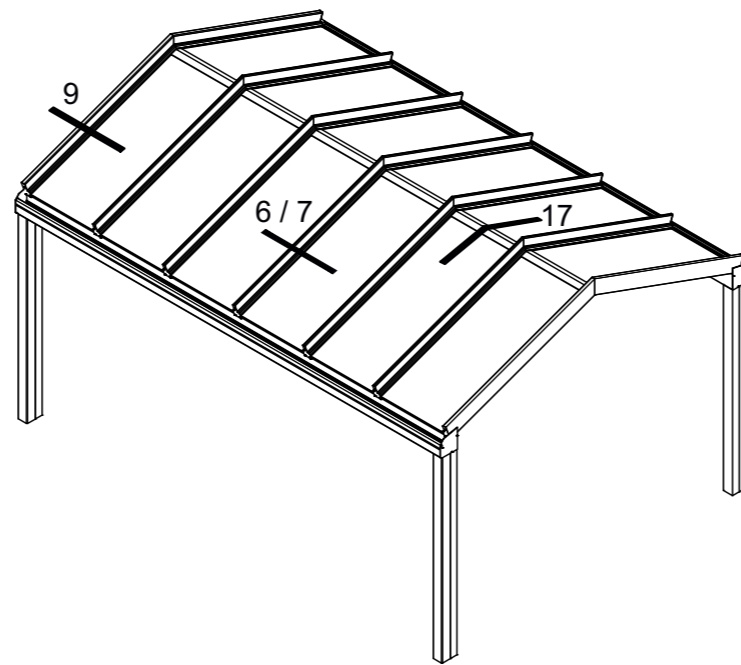
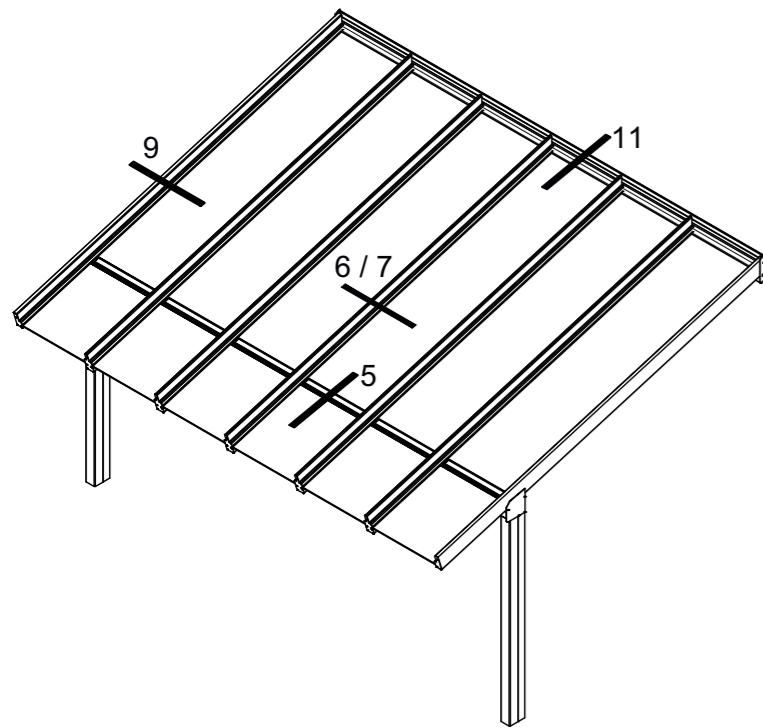
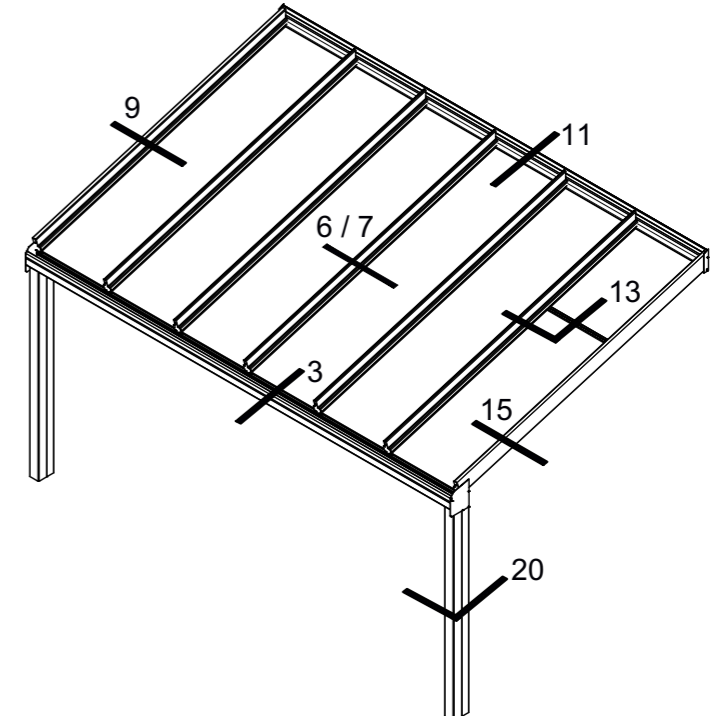
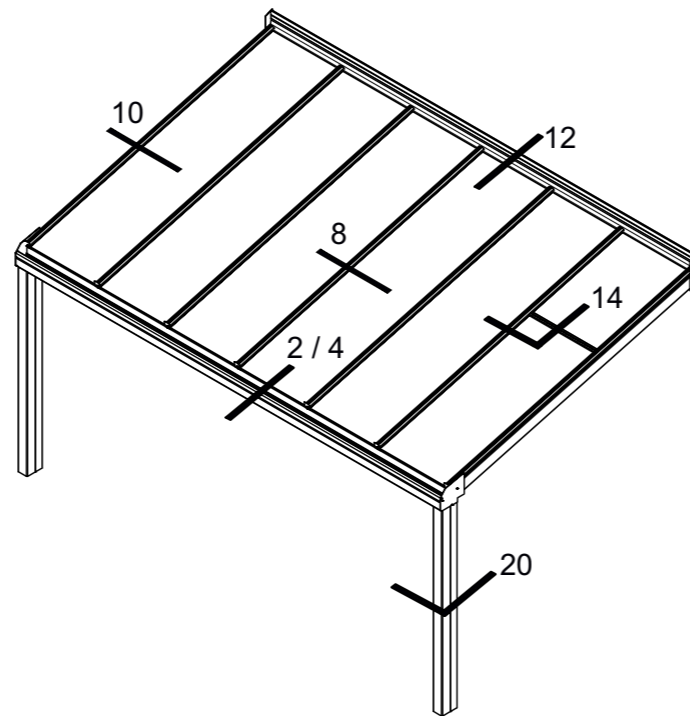
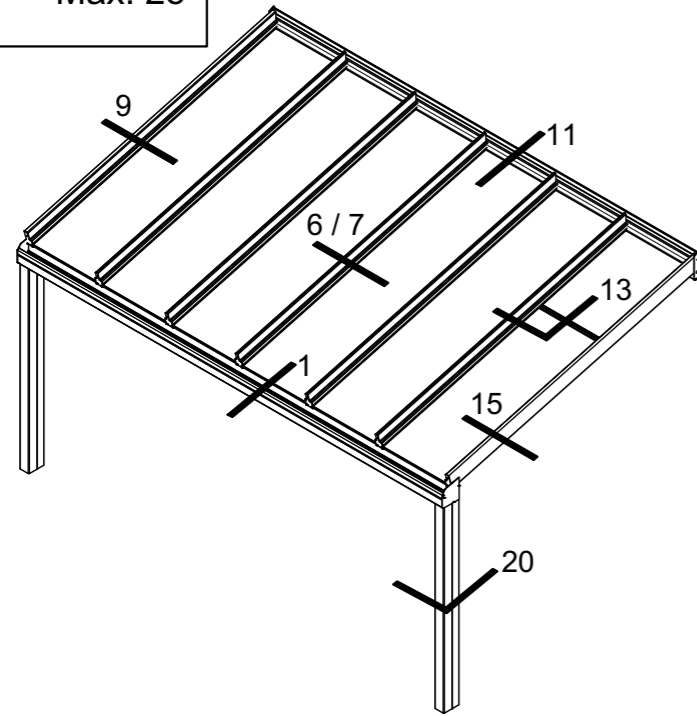

DOORSNEDETEKENINGEN - SECTIONS DE NOEUDS - PROFILKOMBINATIONEN - SECTION DRAWINGS

 Min. 5° < Max. 25°

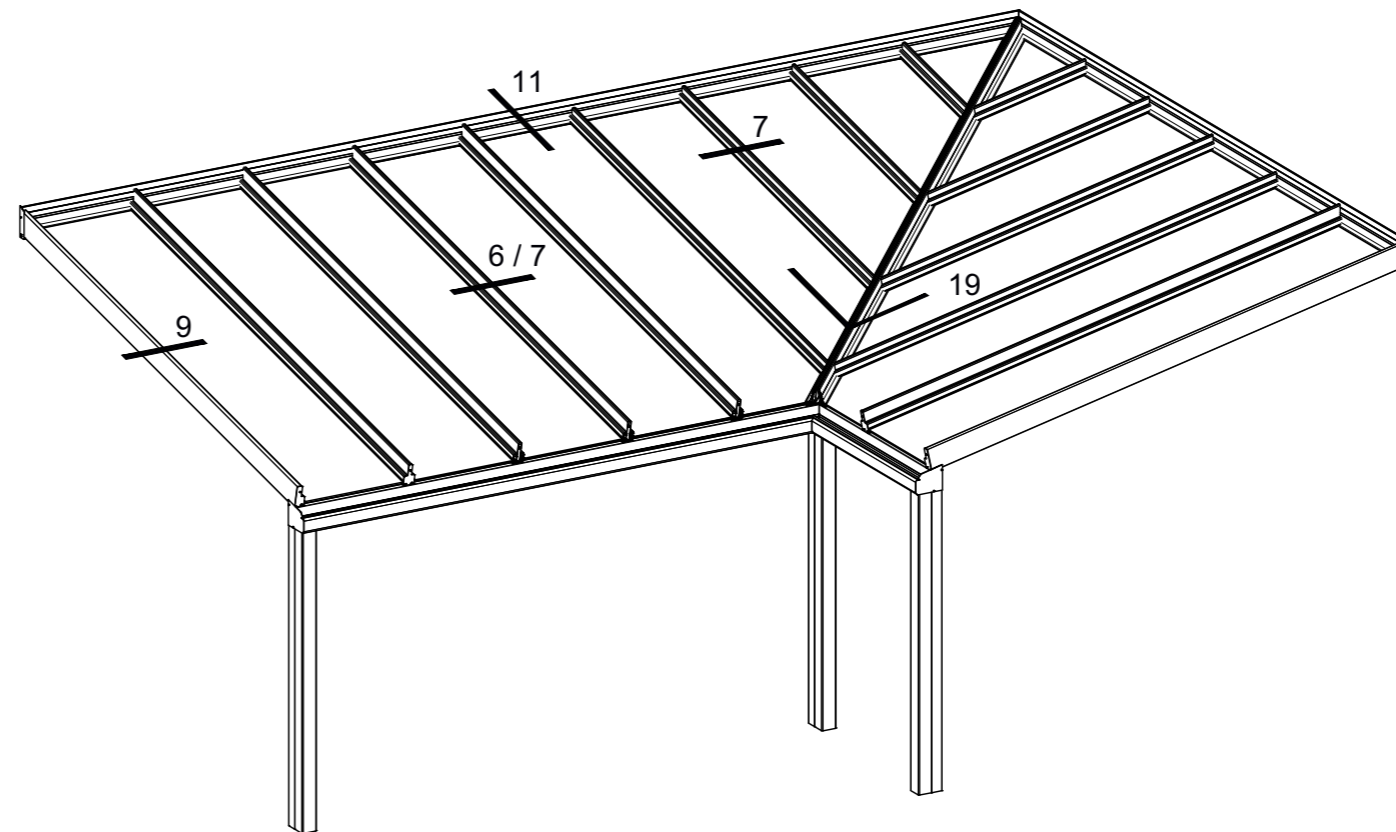
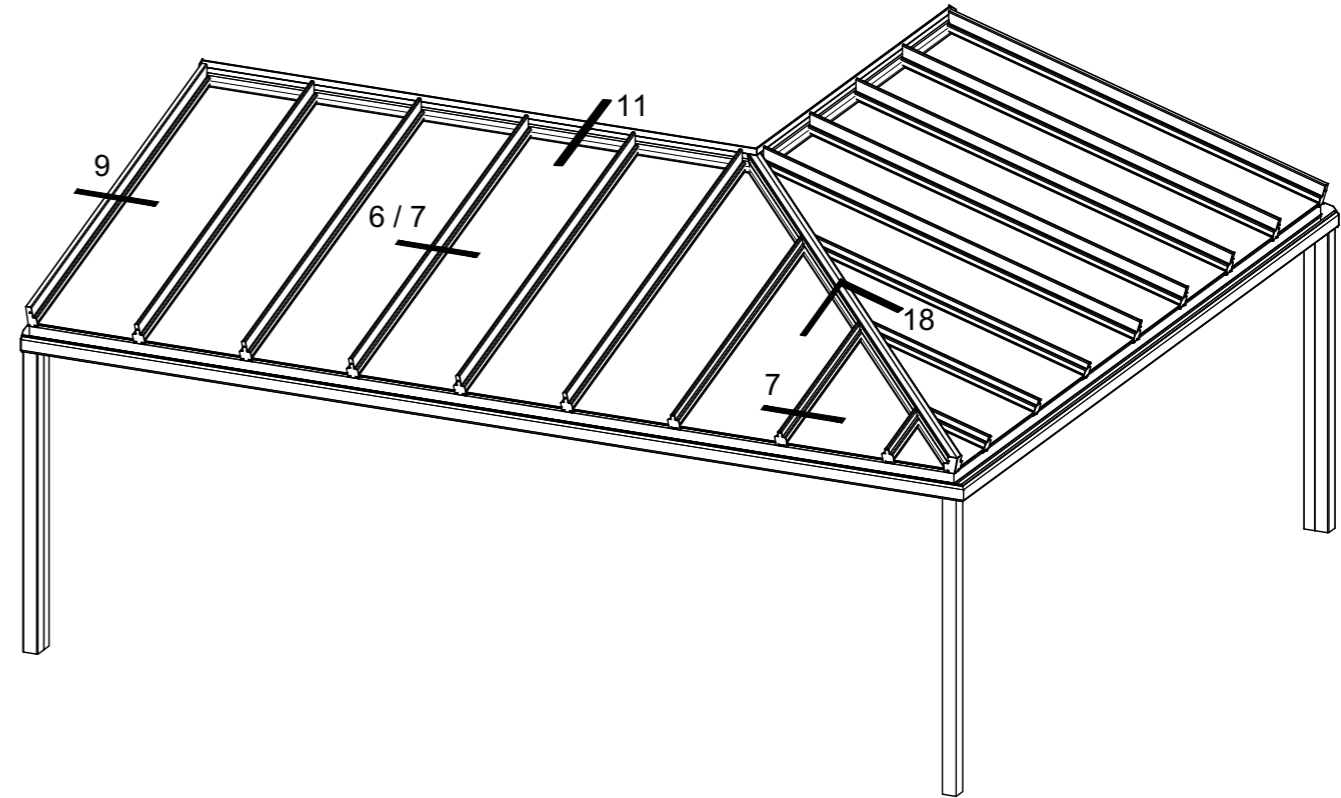
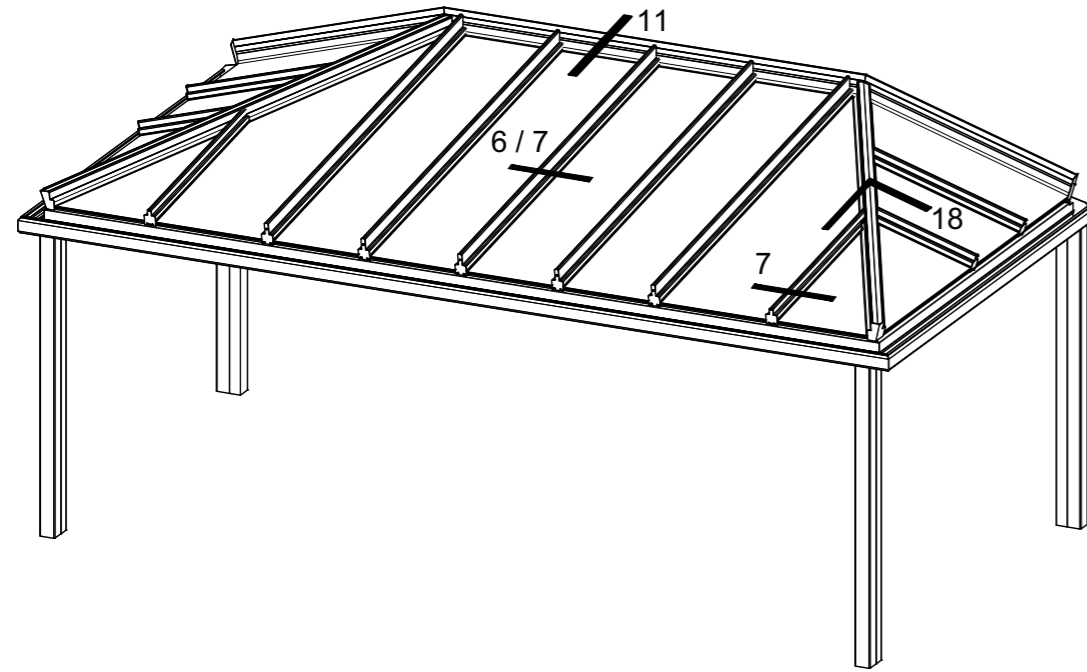

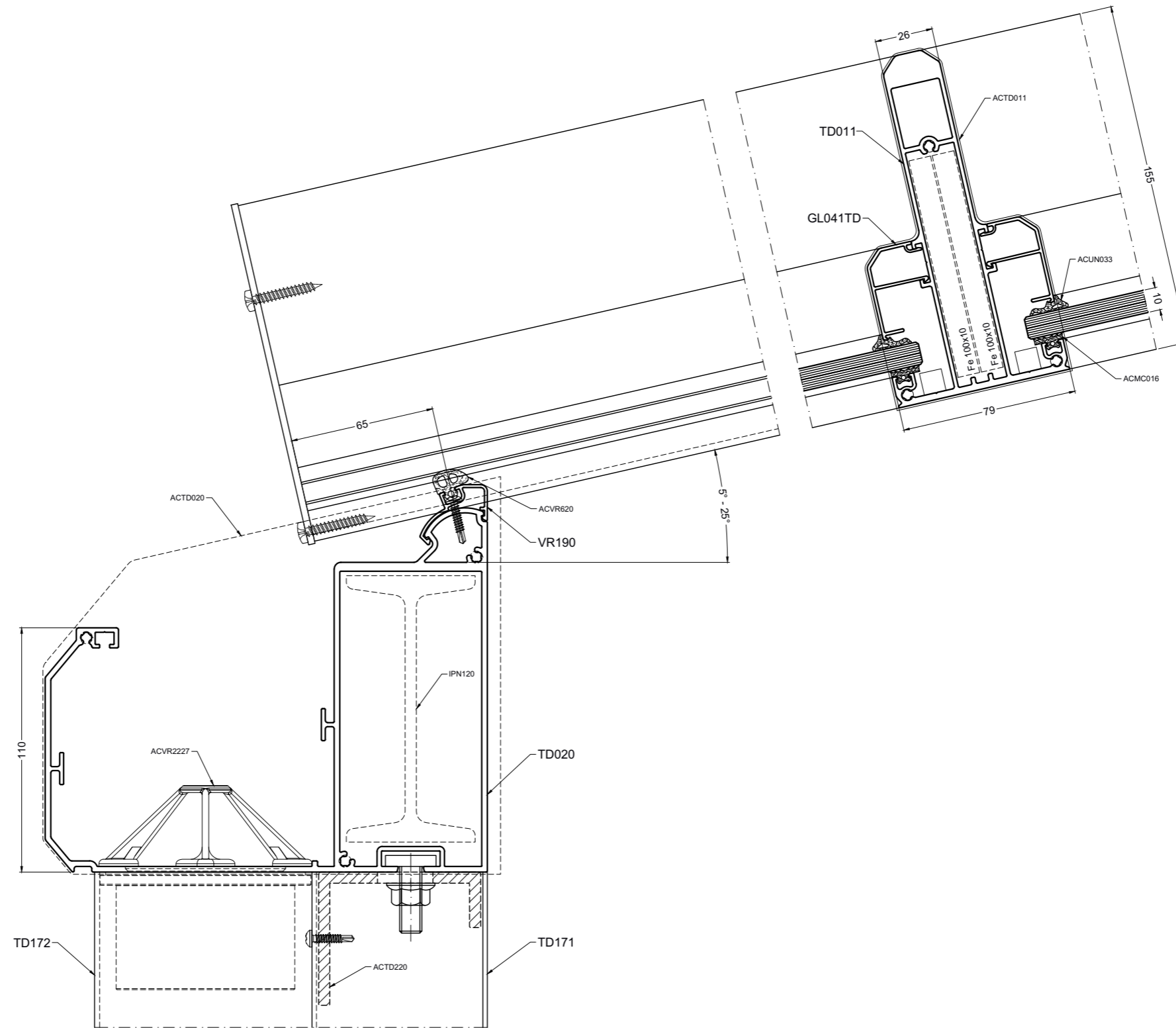

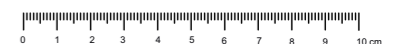
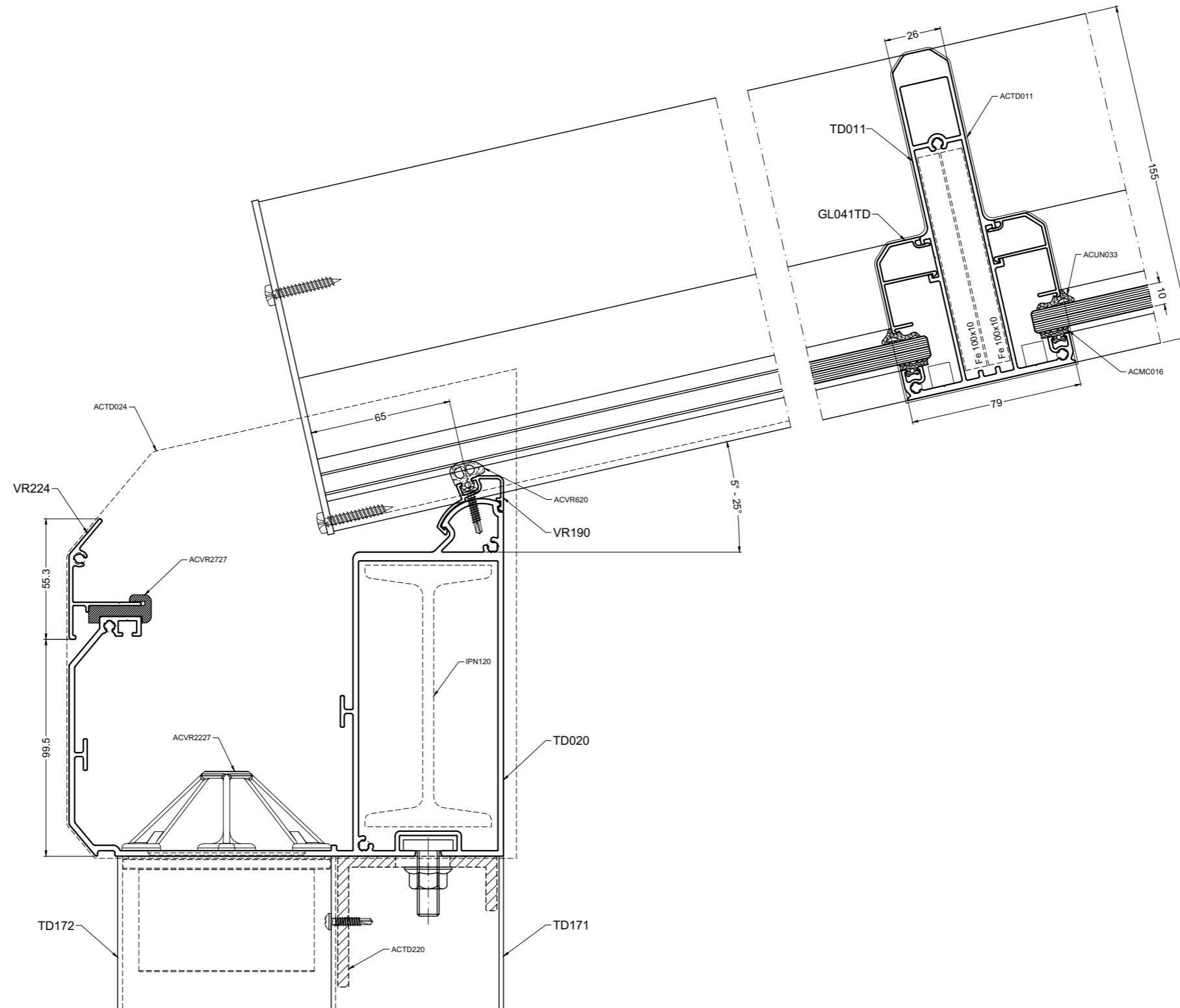

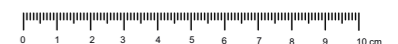
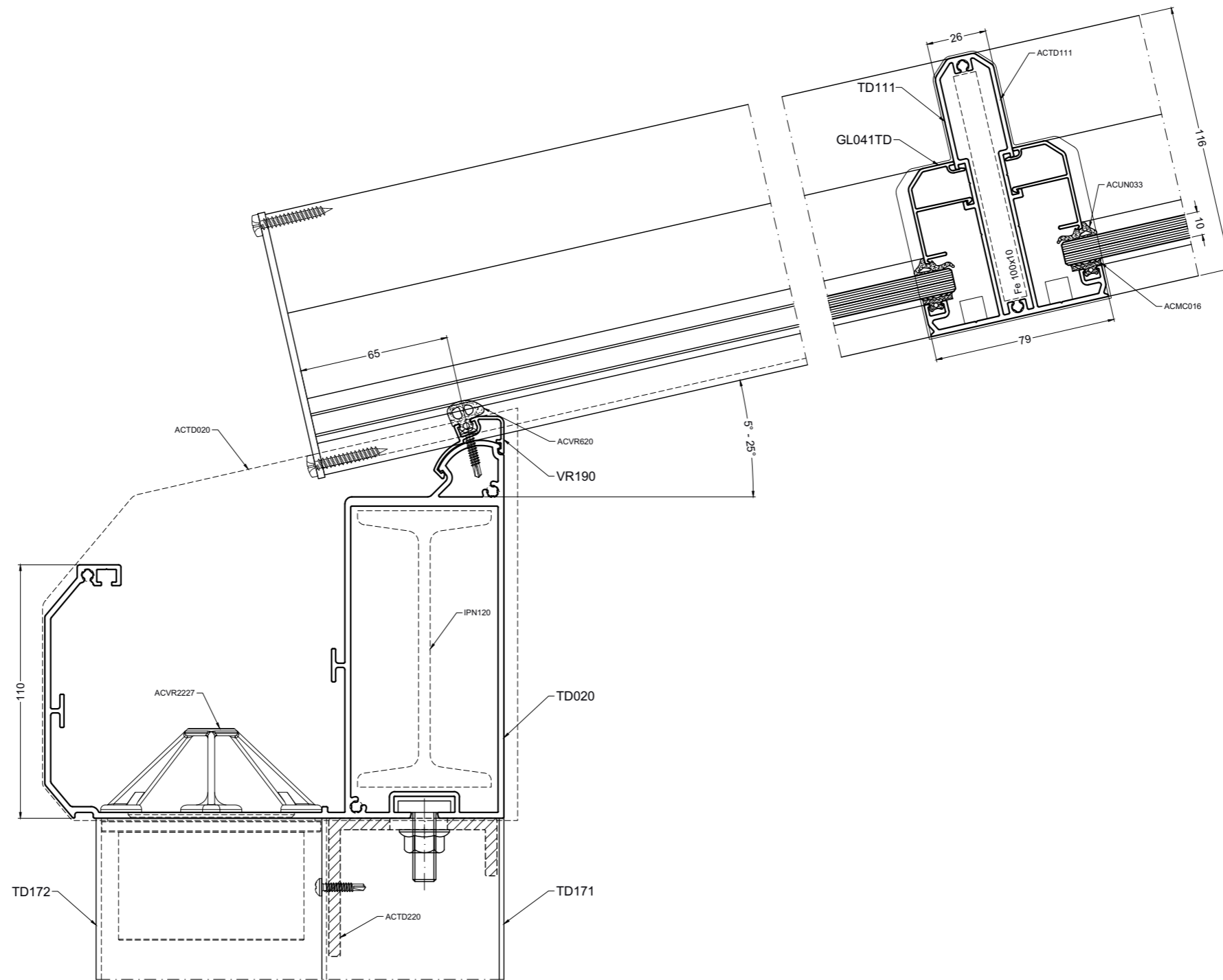

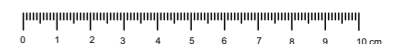
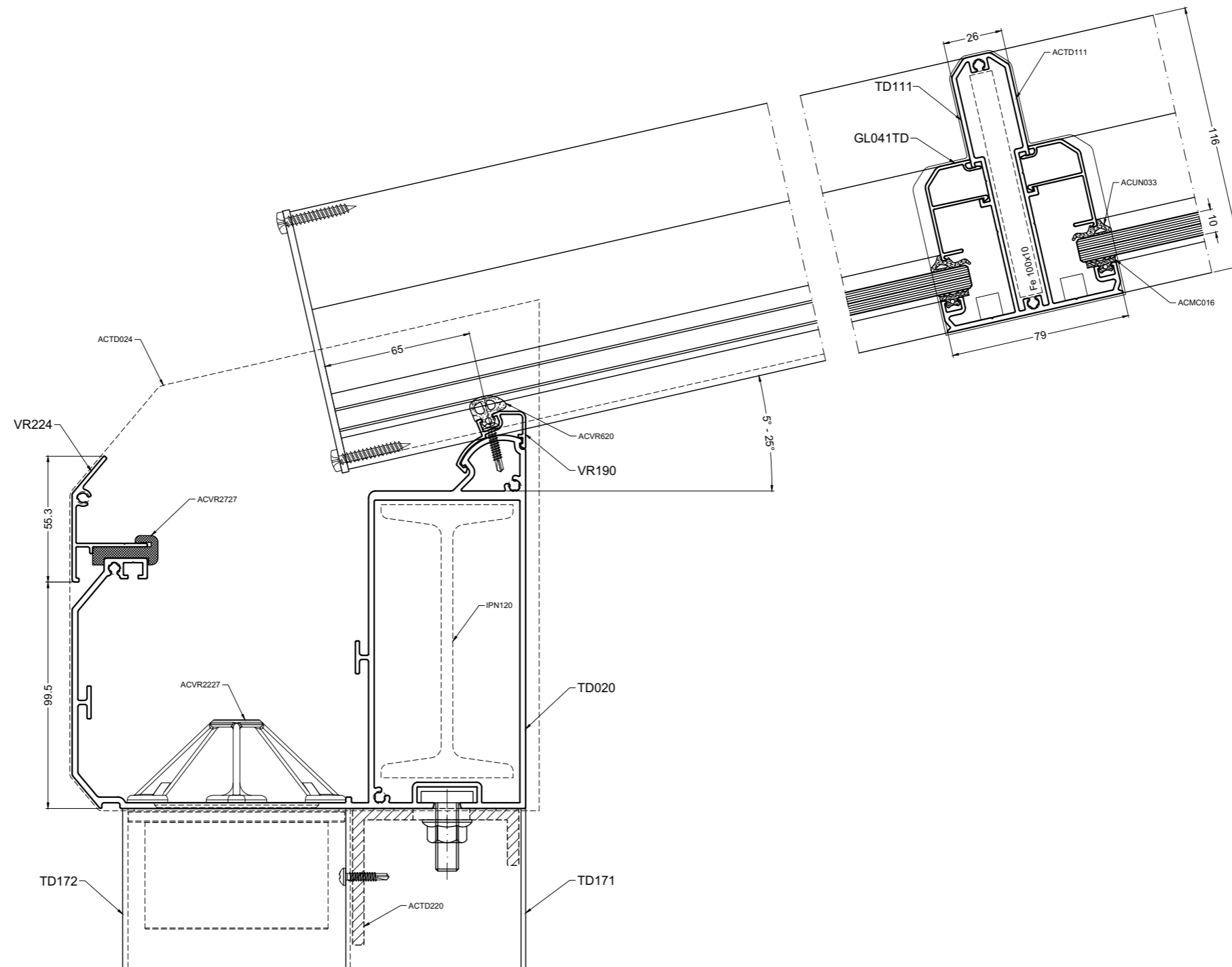



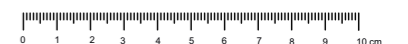
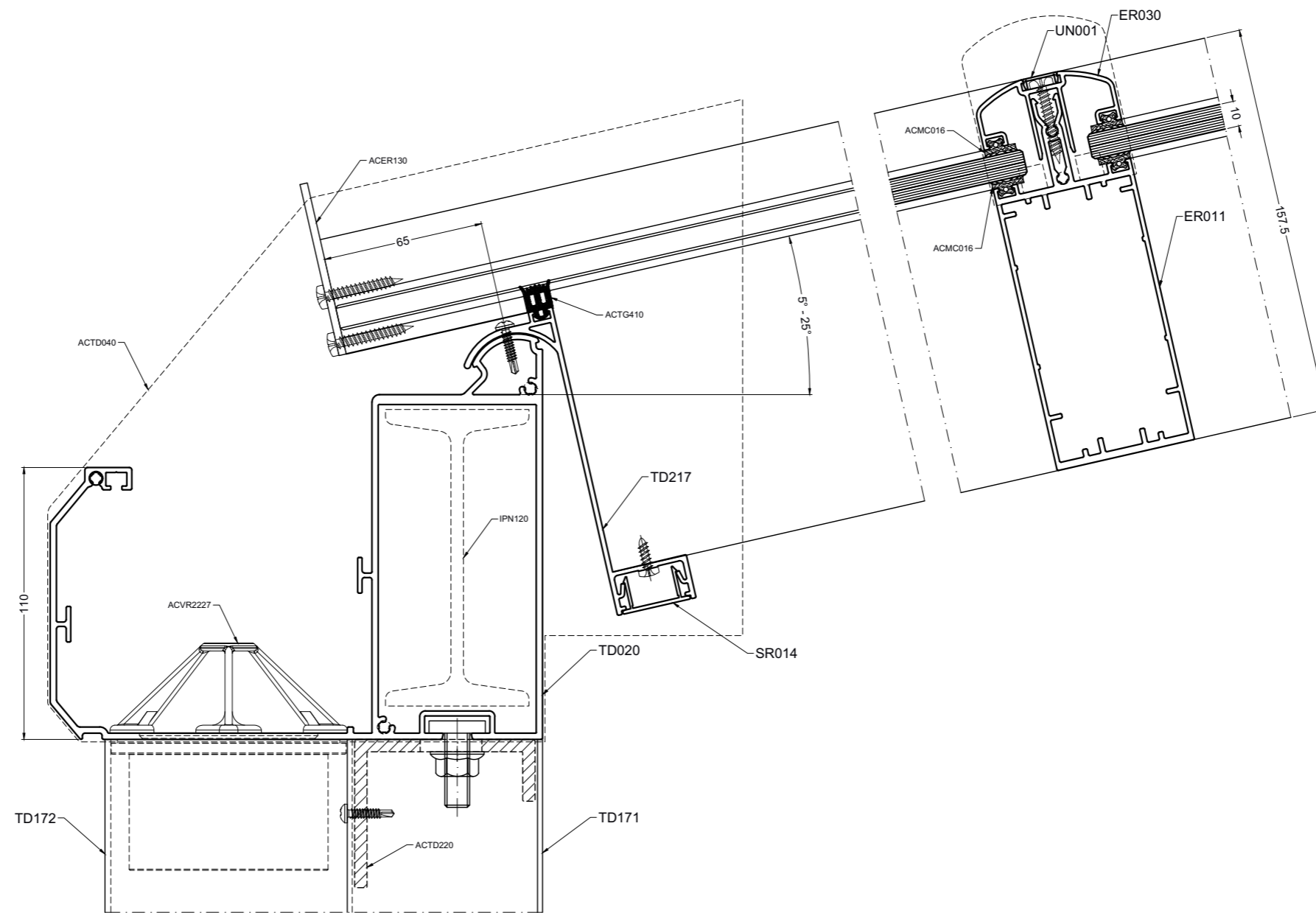

TD020\_005

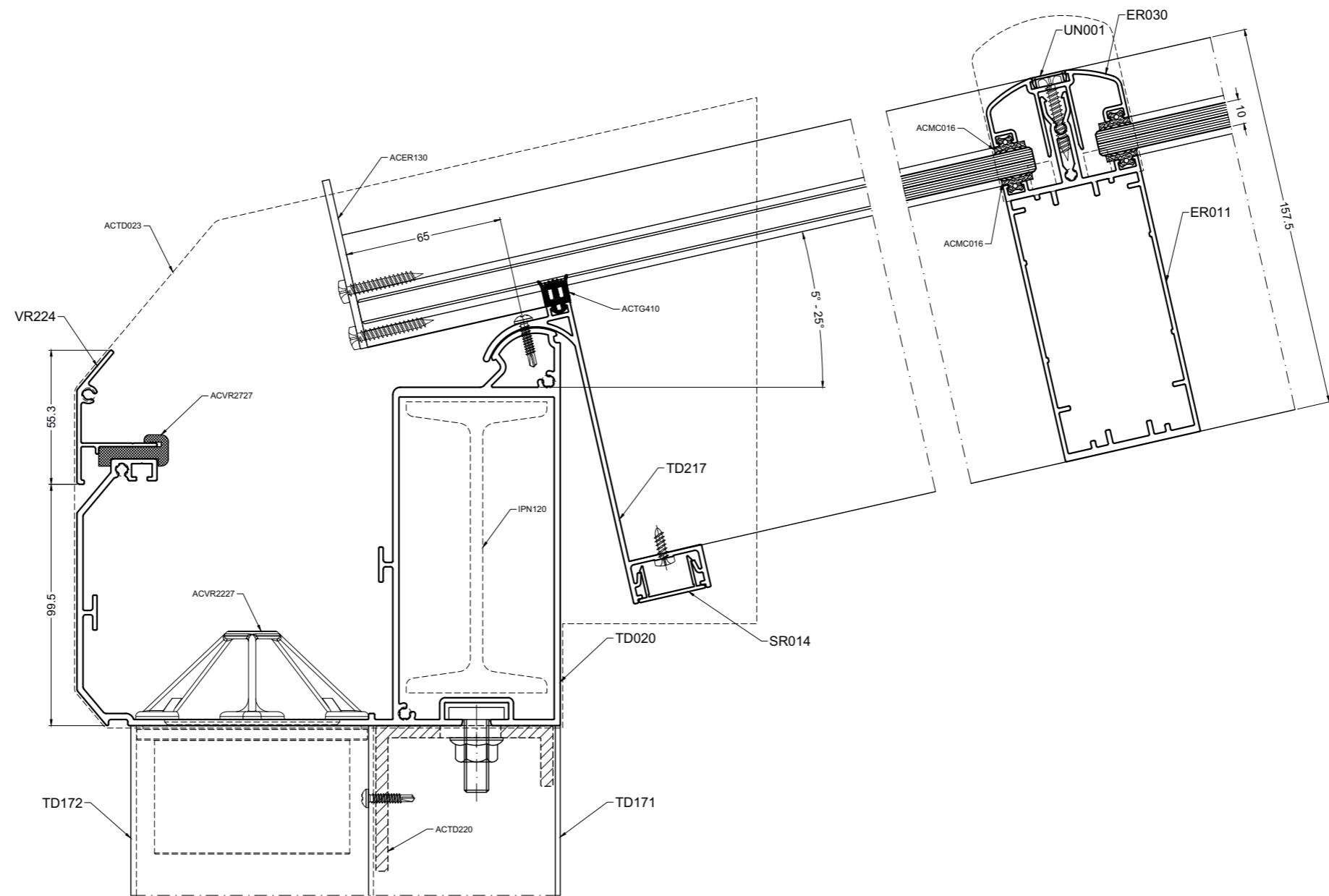

TD020\_006



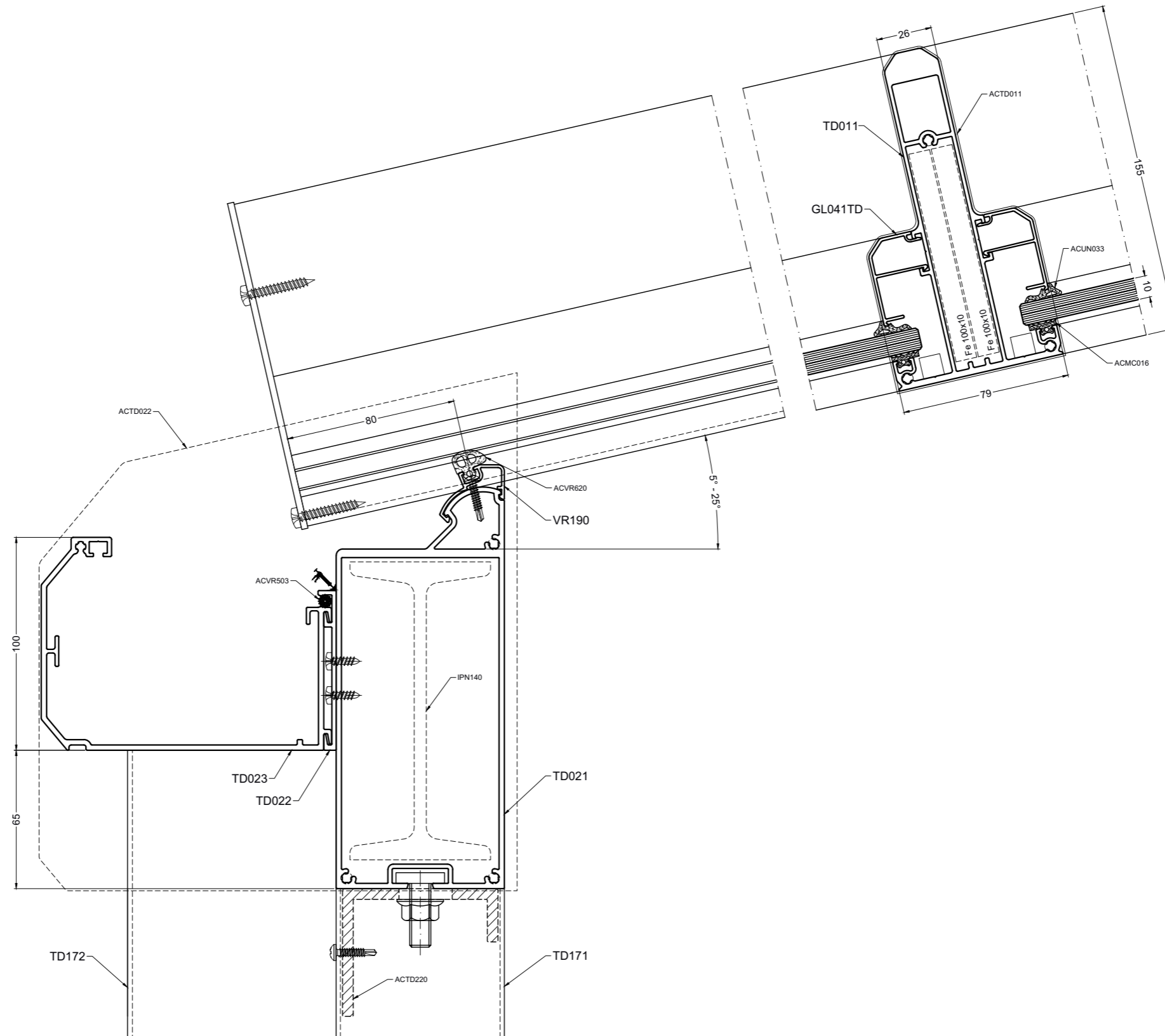

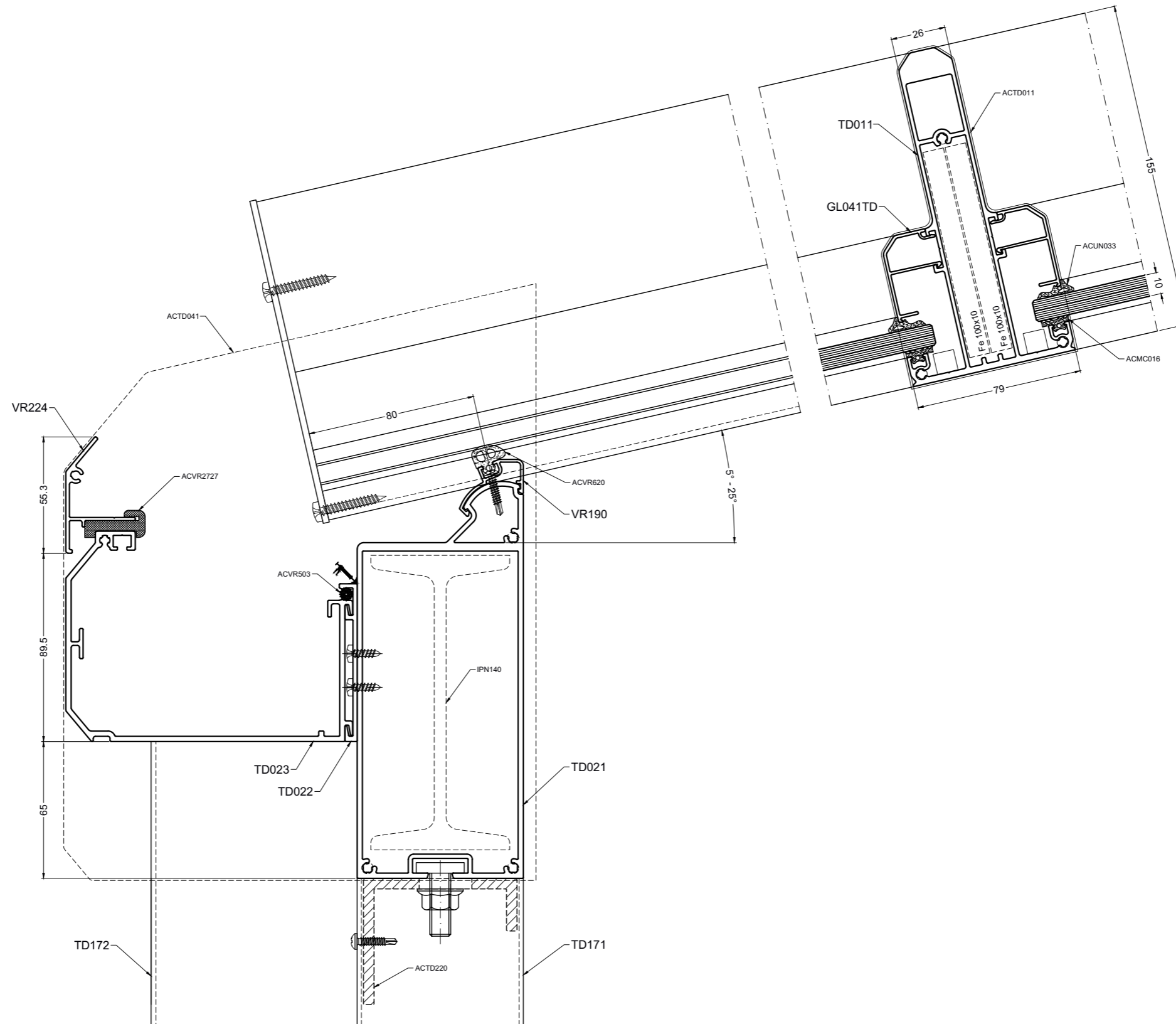

TD021\_002

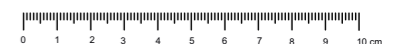

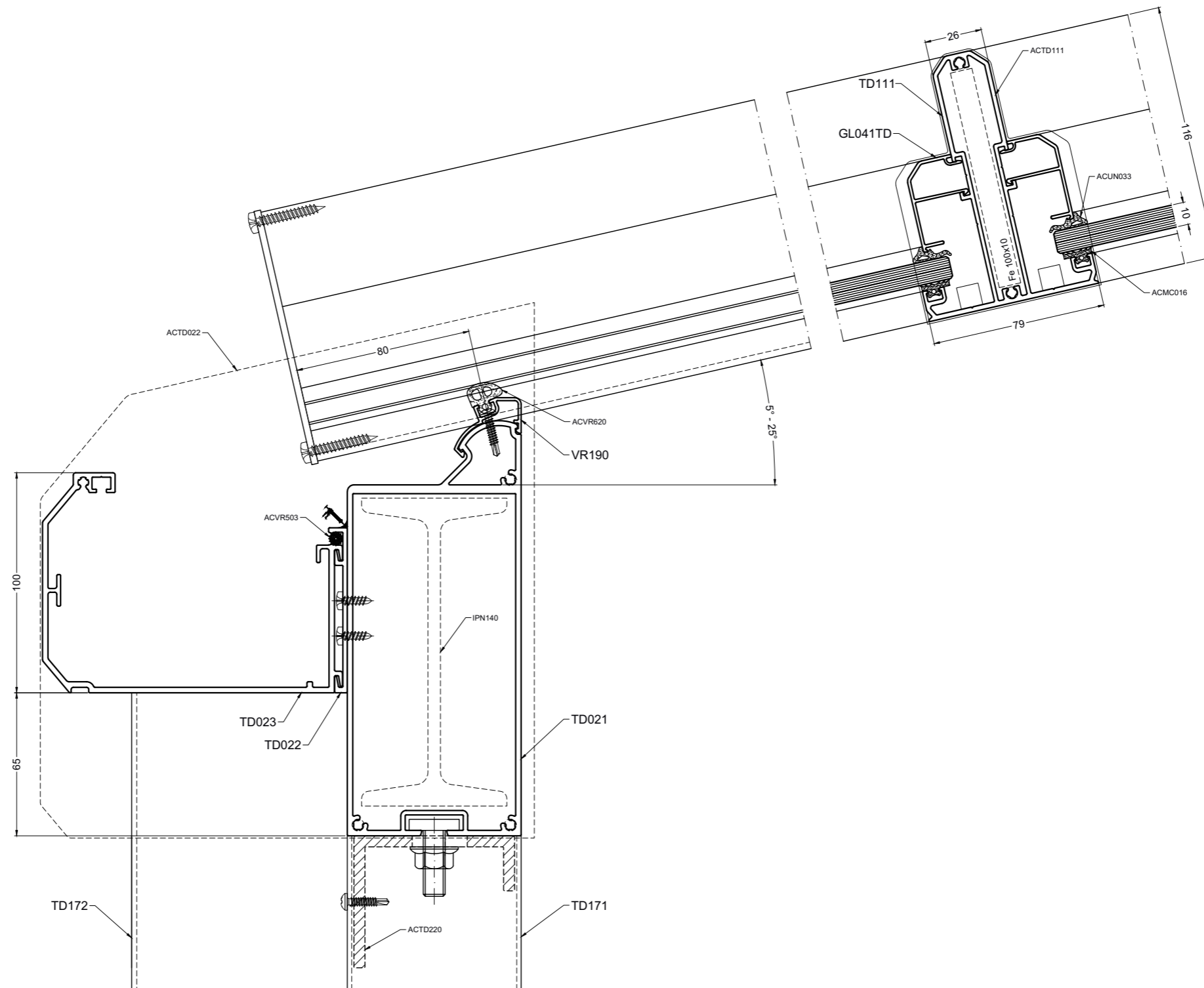

DOORSNEDETEKENINGEN - SECTIONS DE NOEUDS - PROFILKOMBINATIONEN - SECTION DRAWINGS

TD021\_003



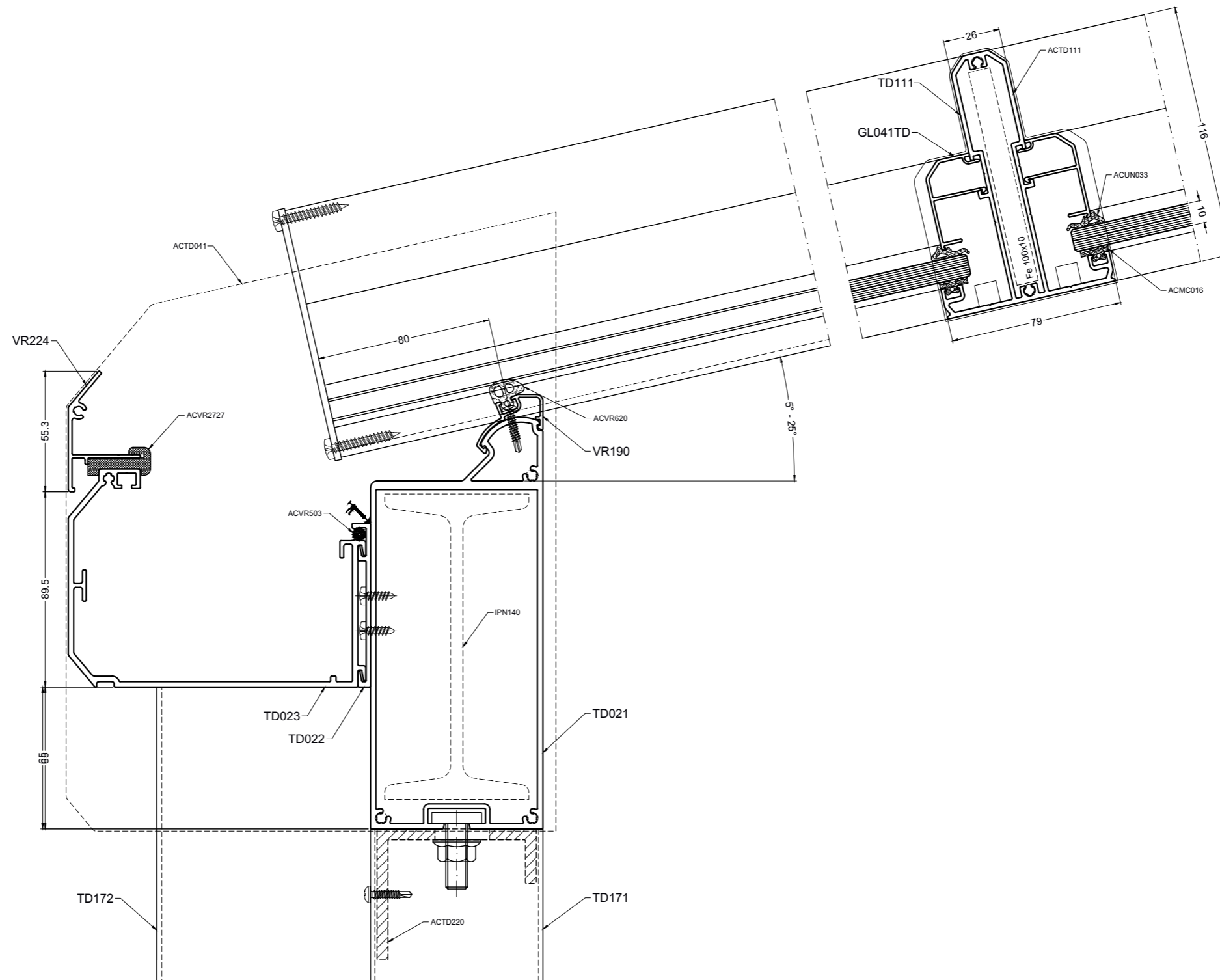

TD021\_004

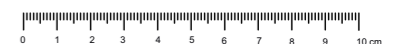

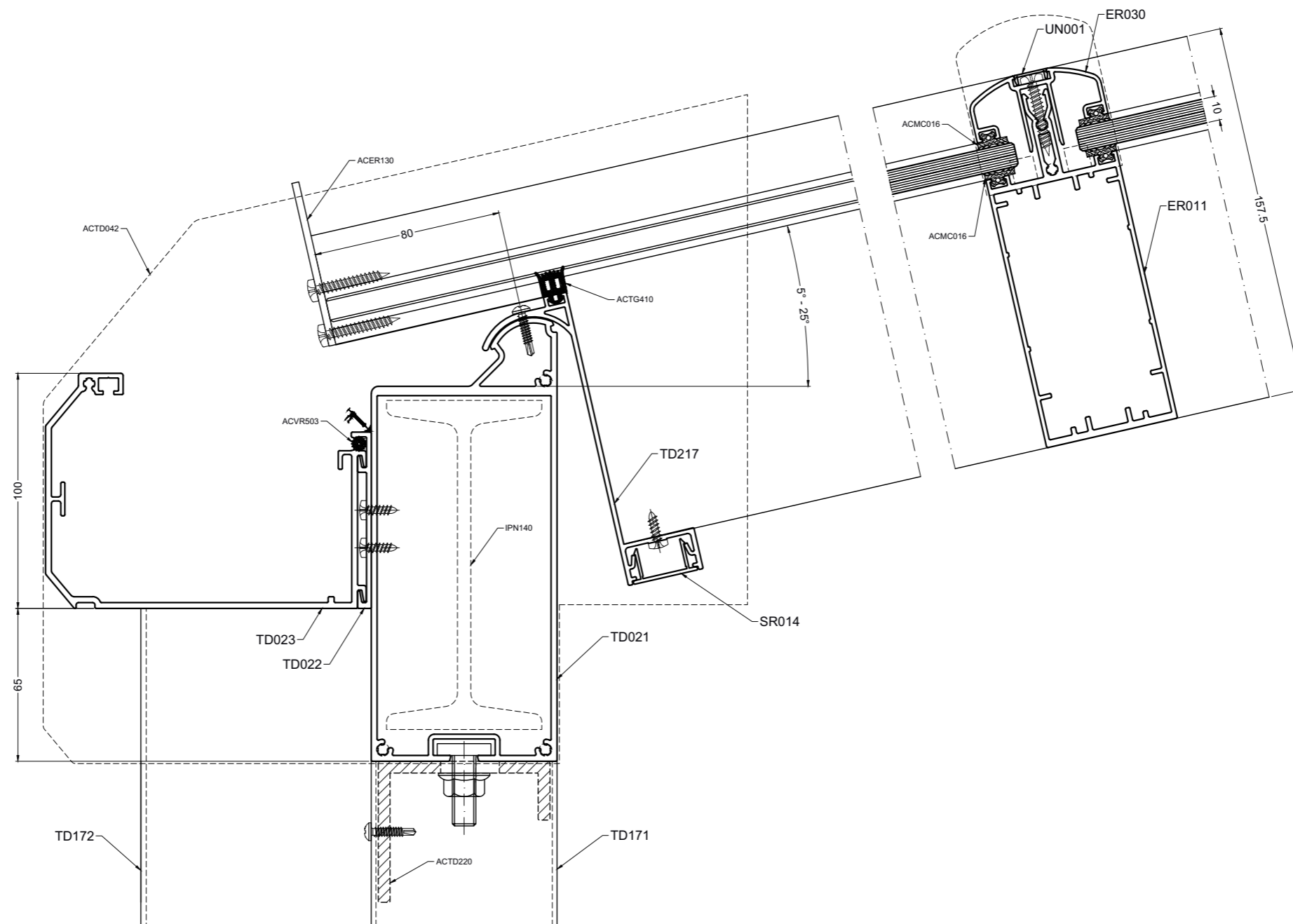

TD021\_005

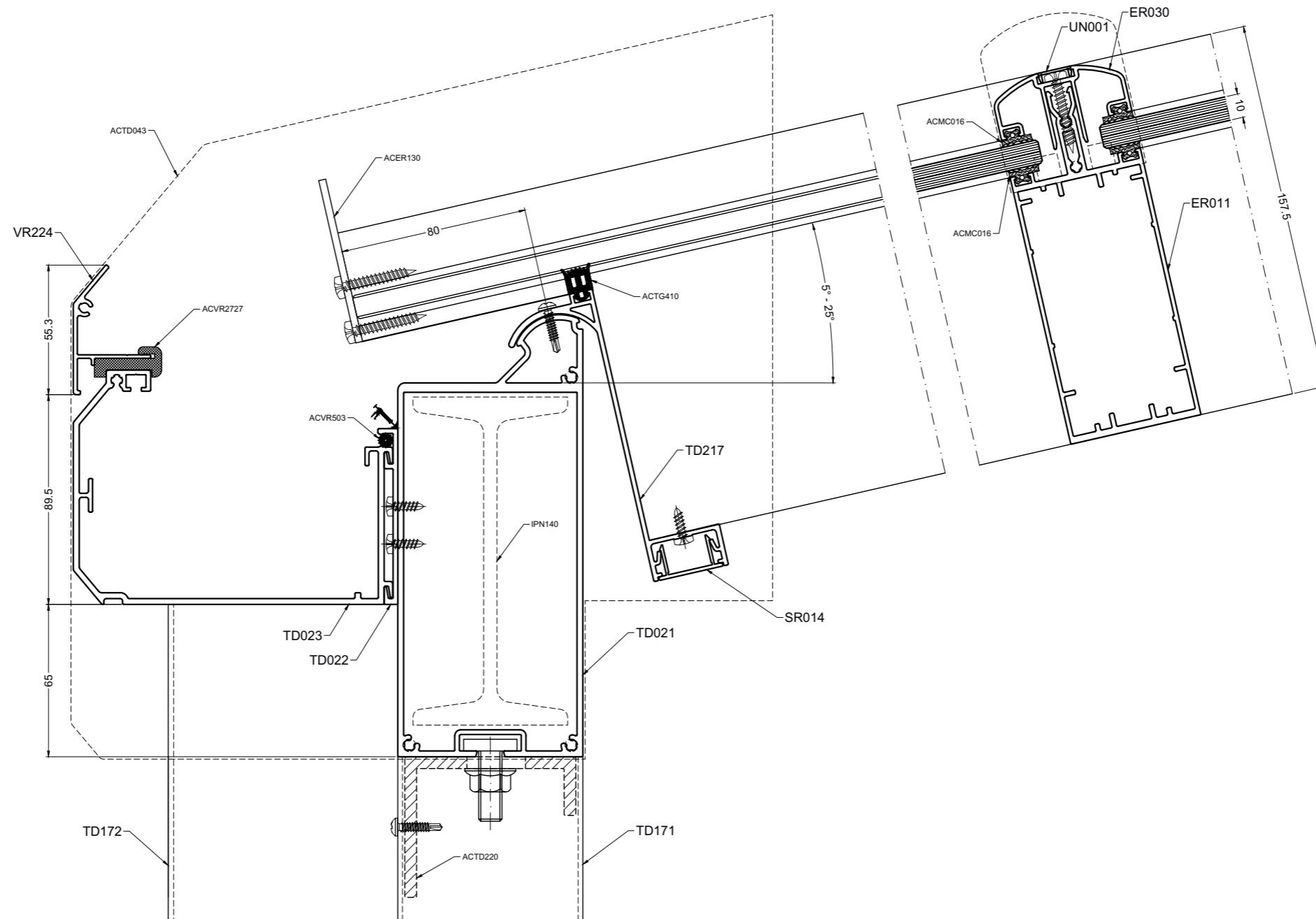

TD021\_006

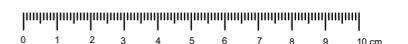



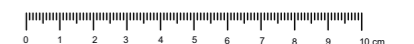
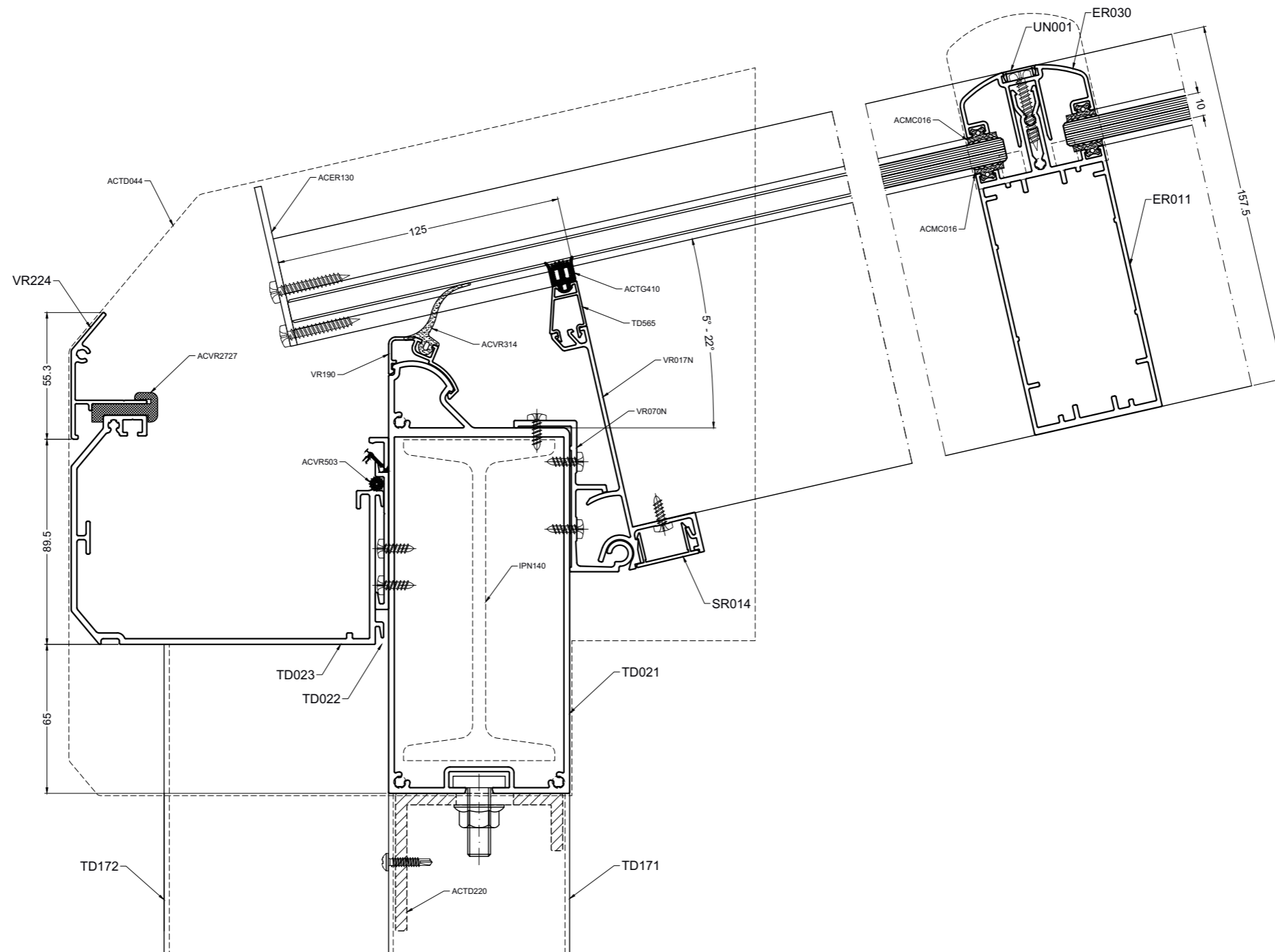

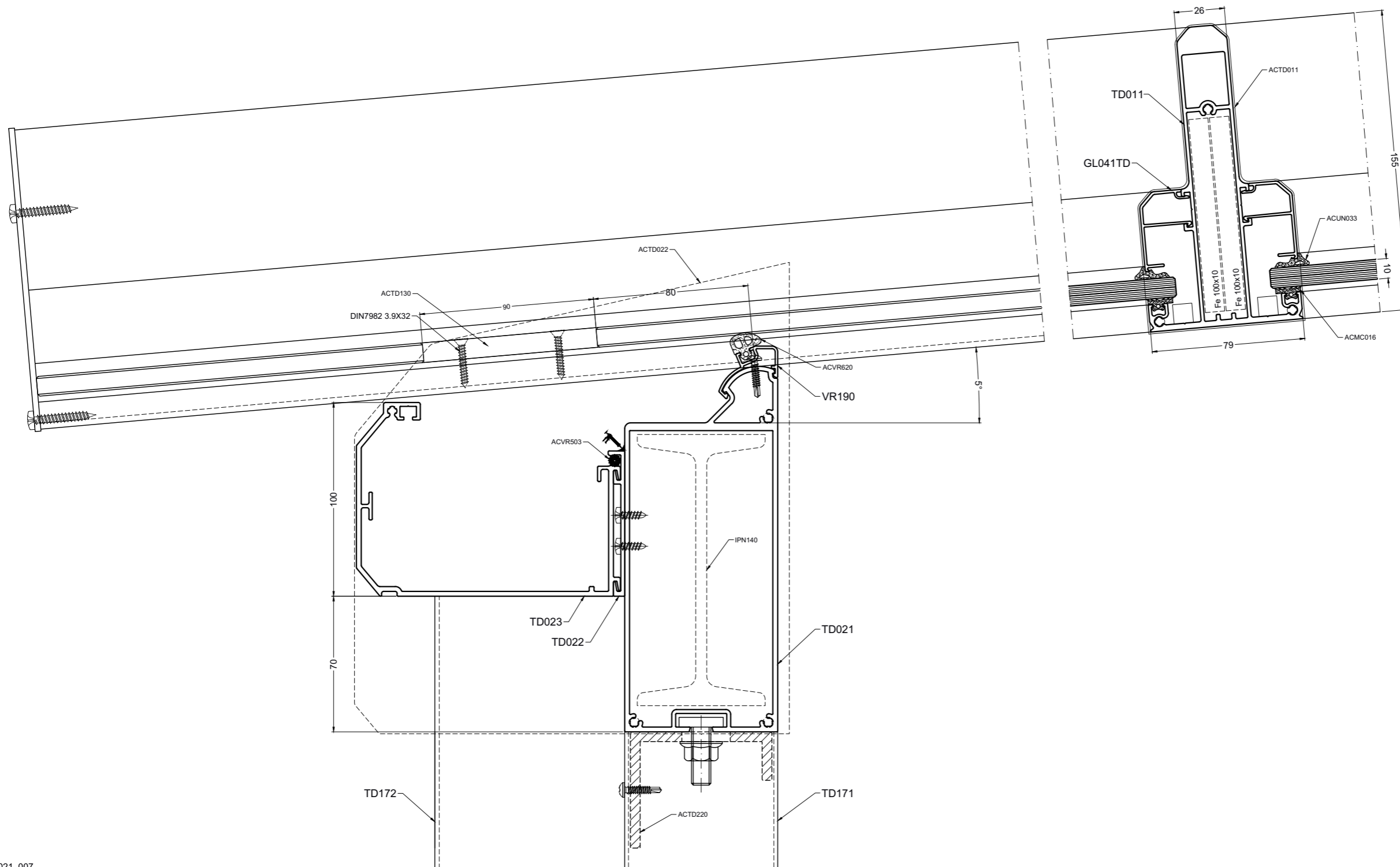

TD021\_007



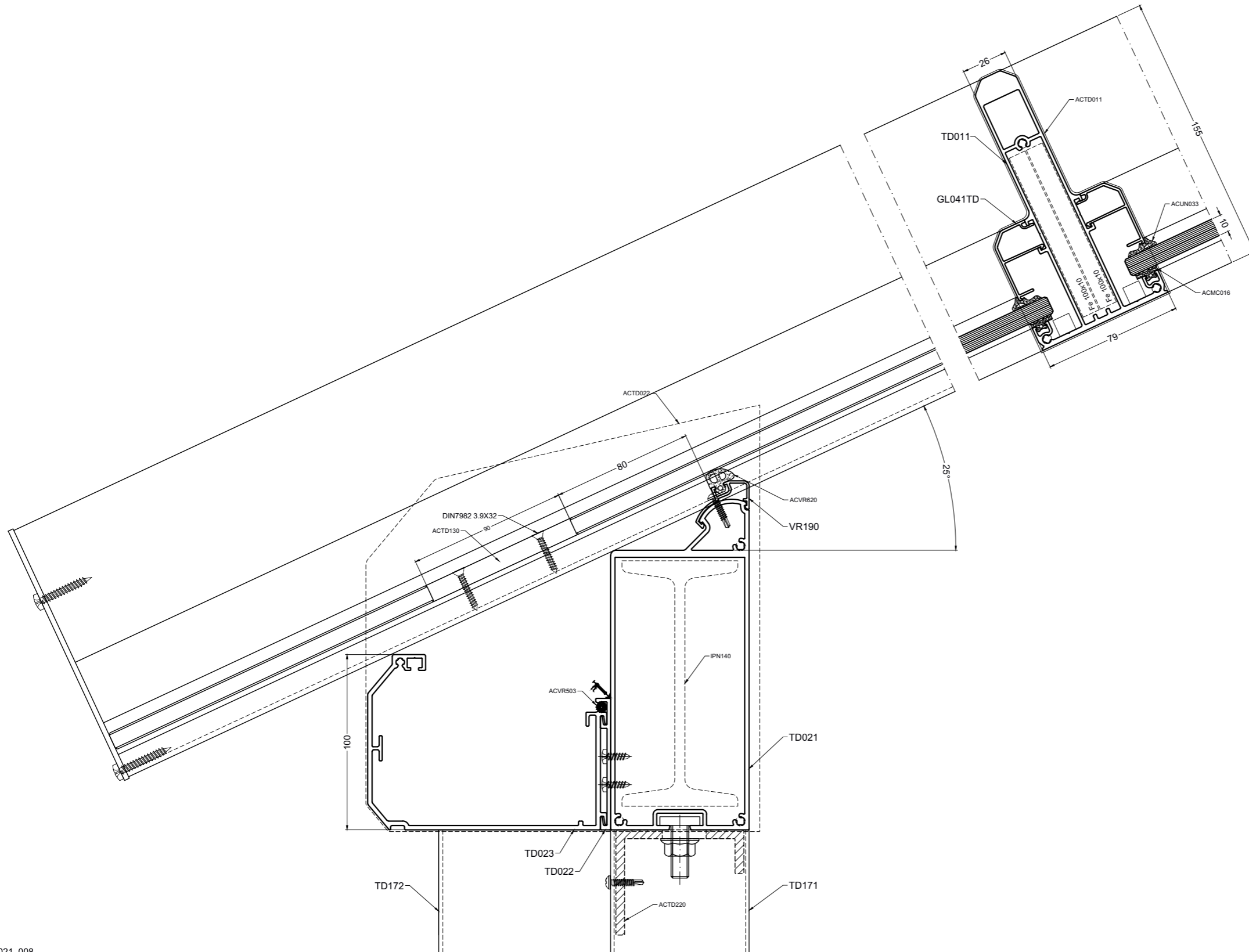

TD021\_008

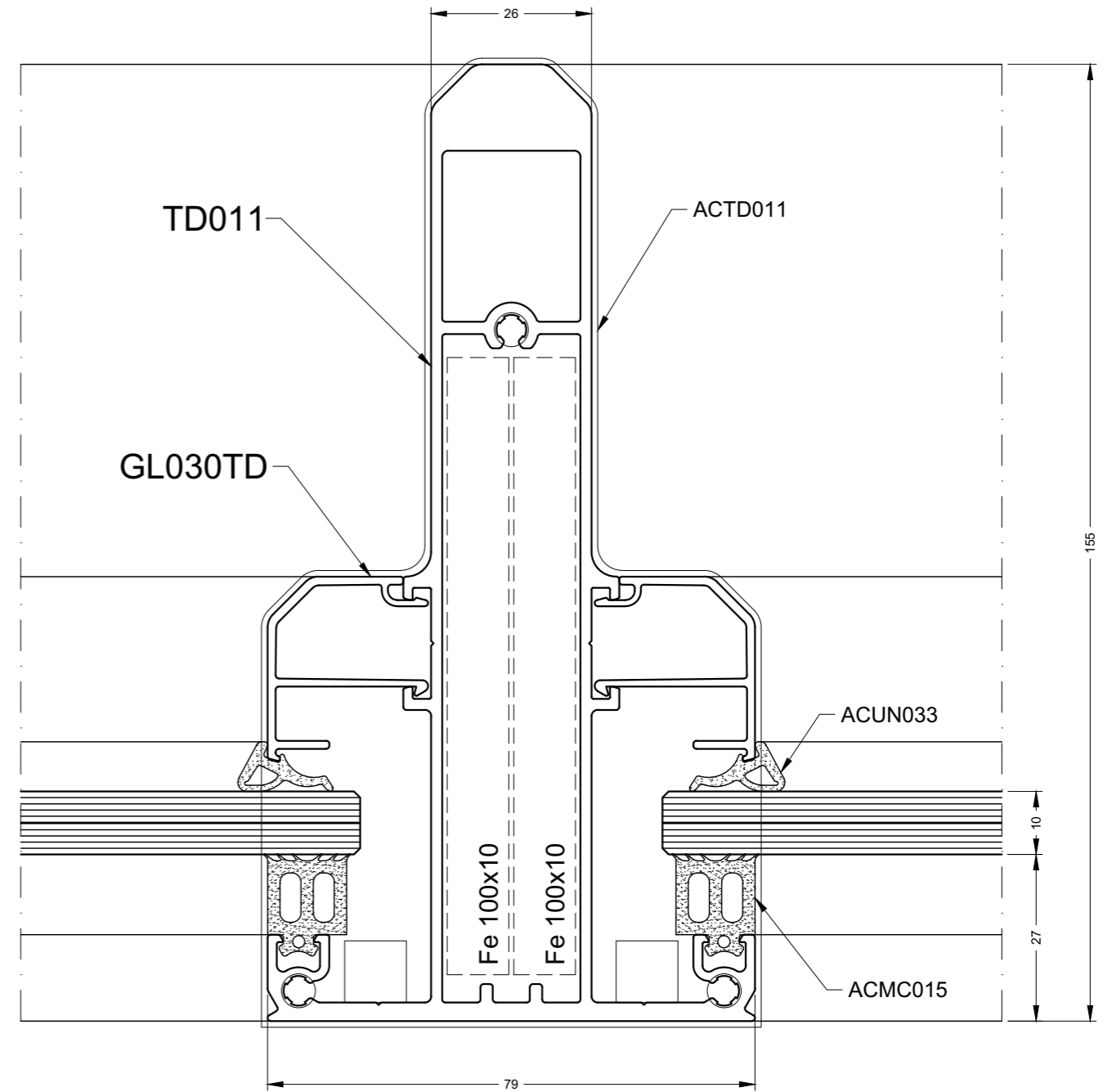
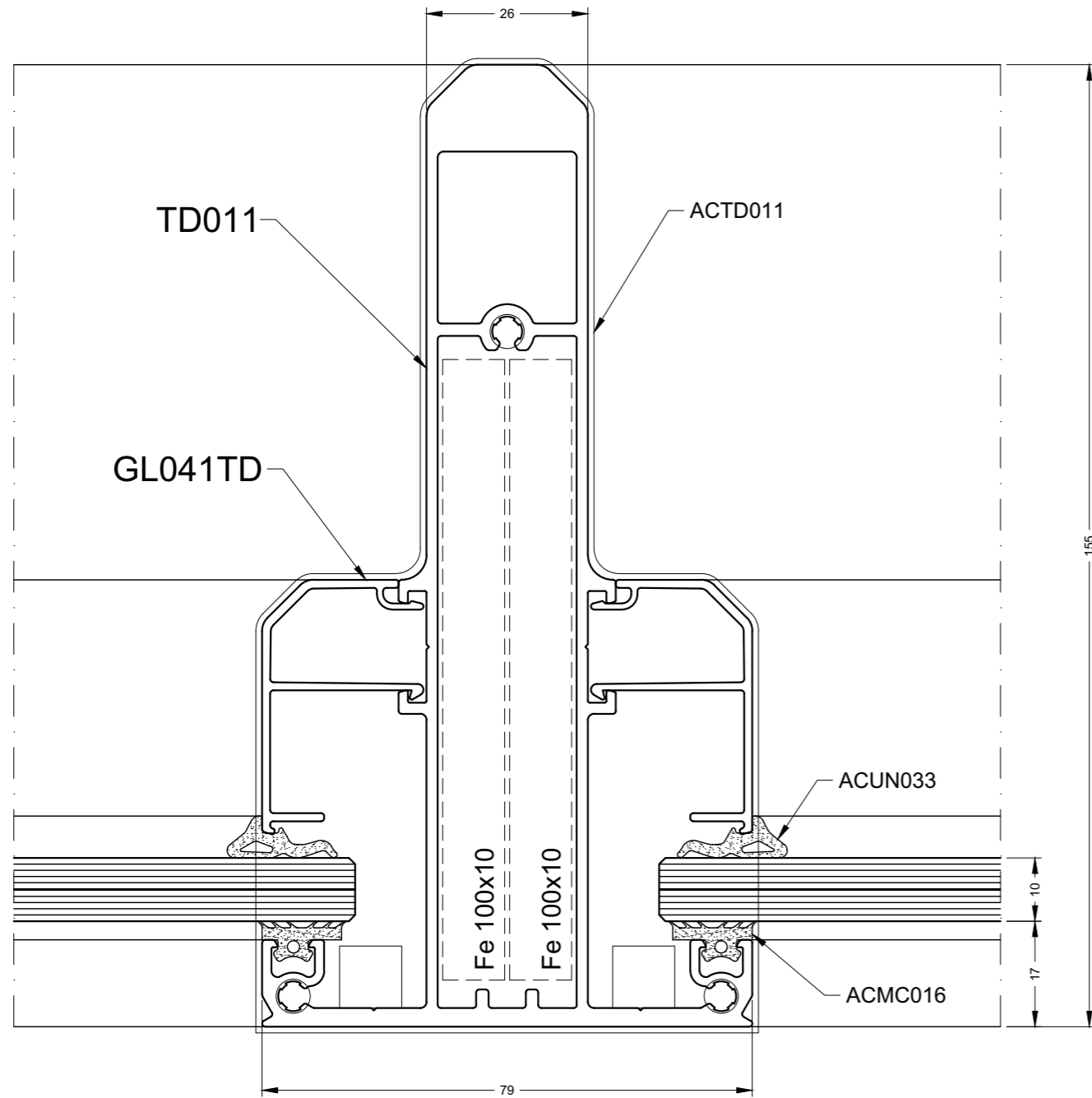

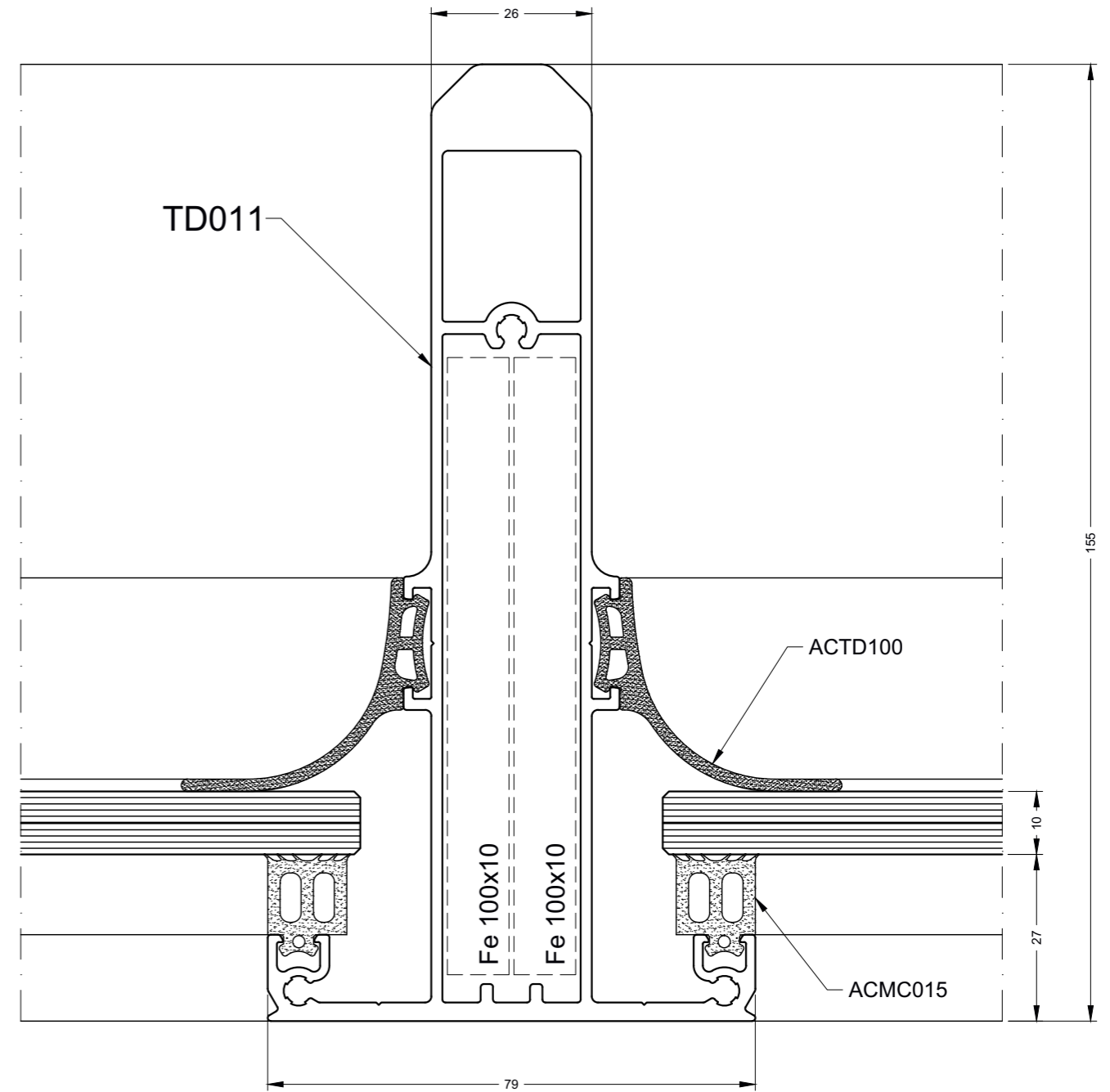
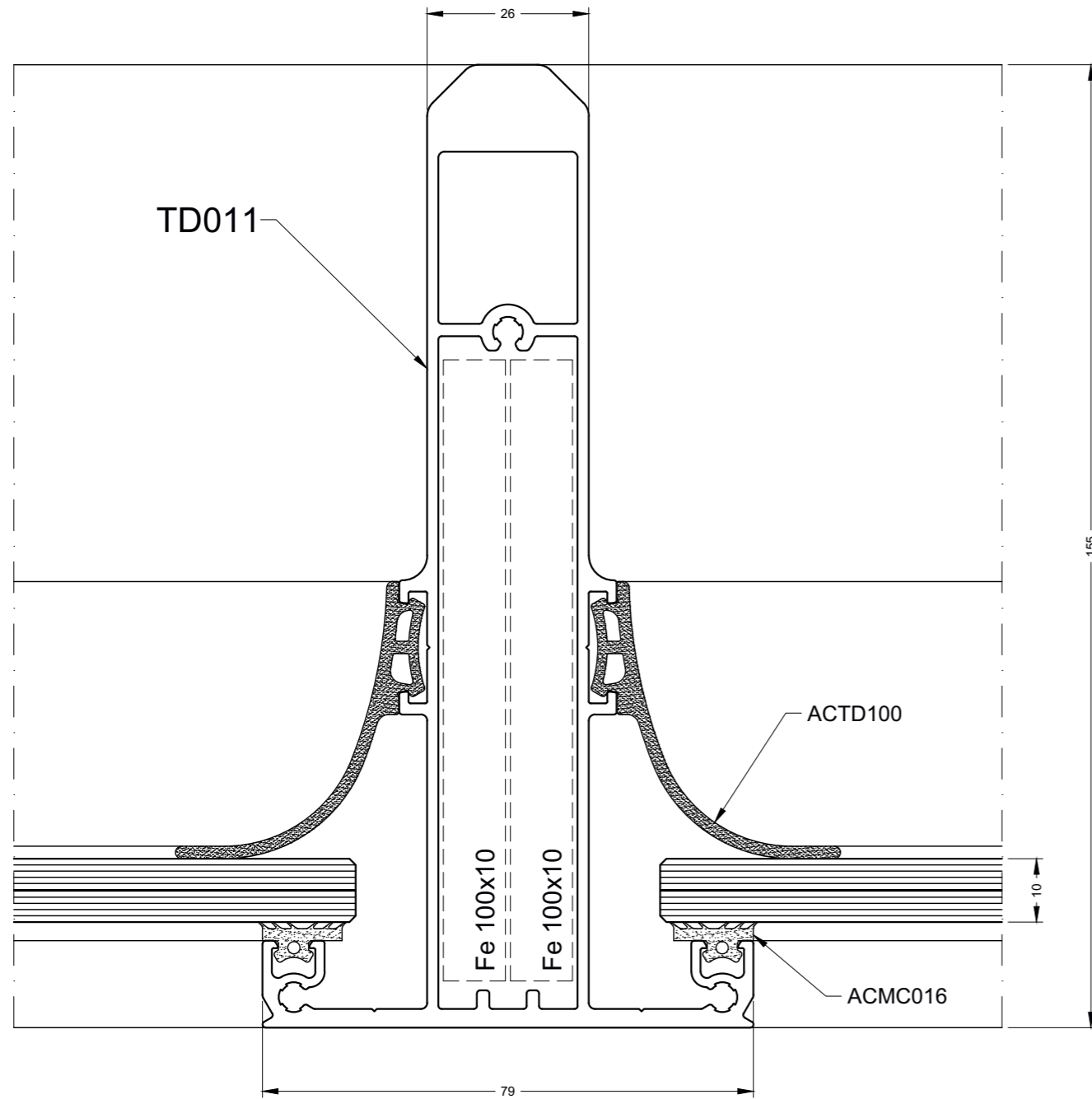

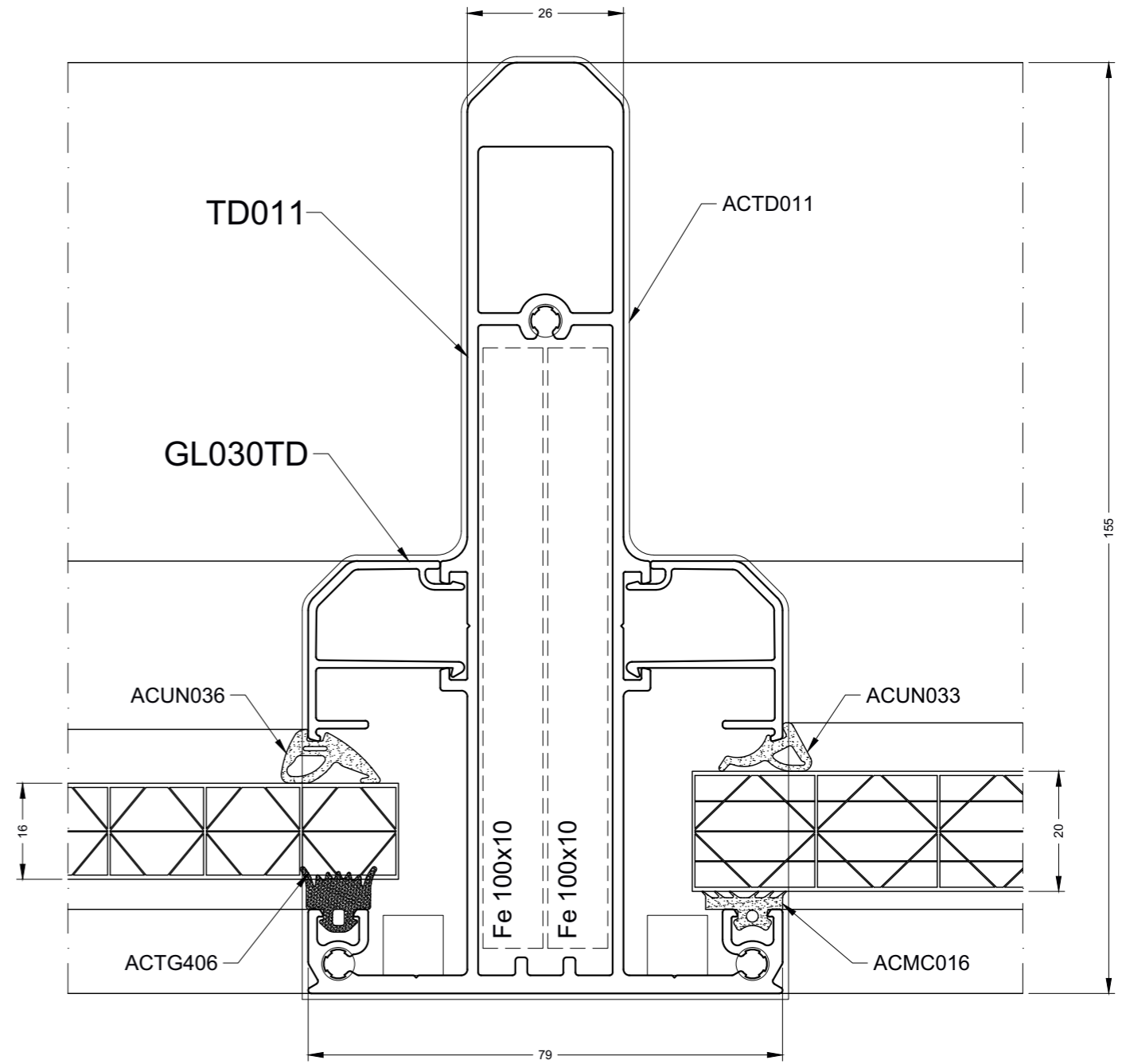
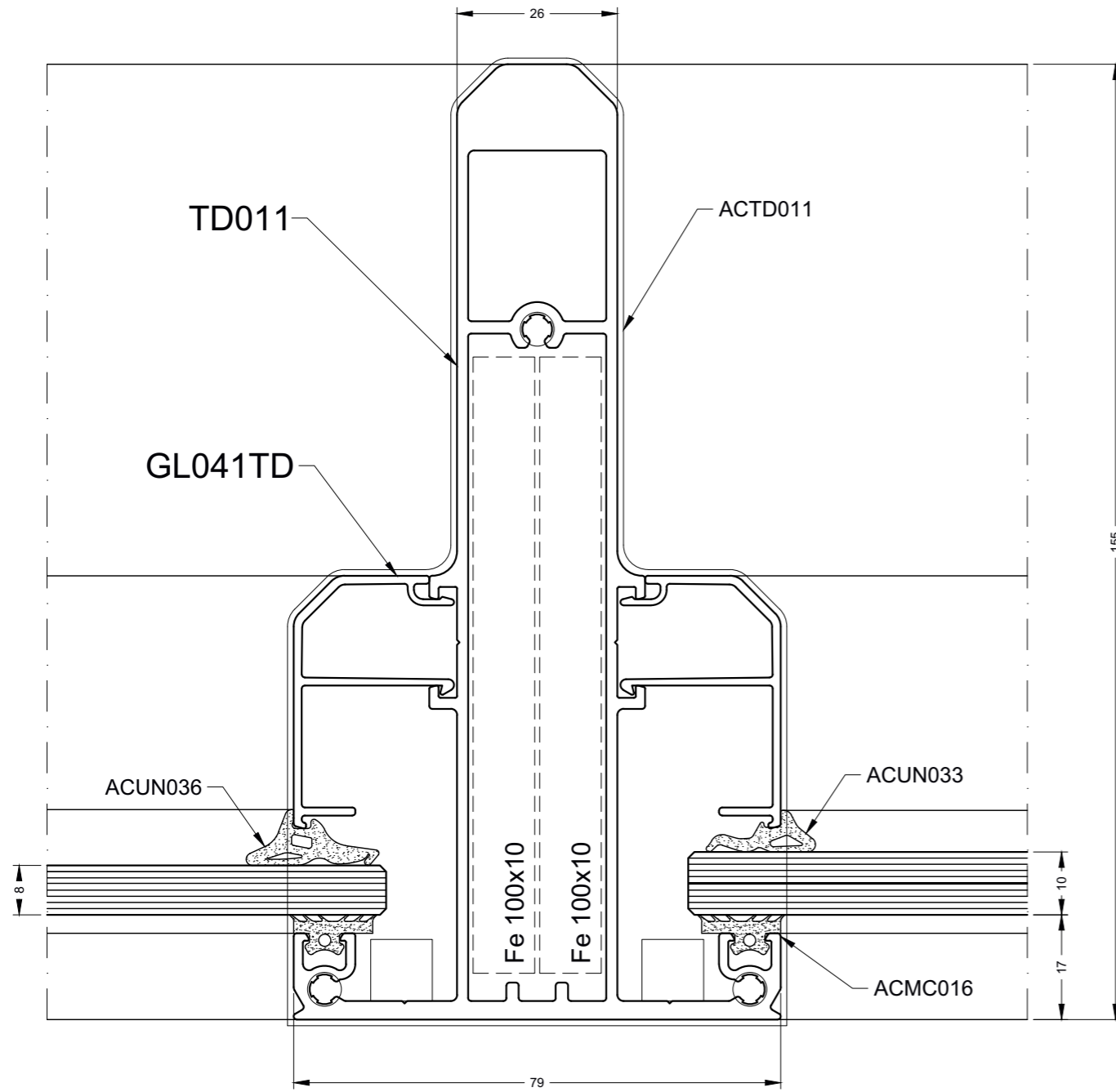

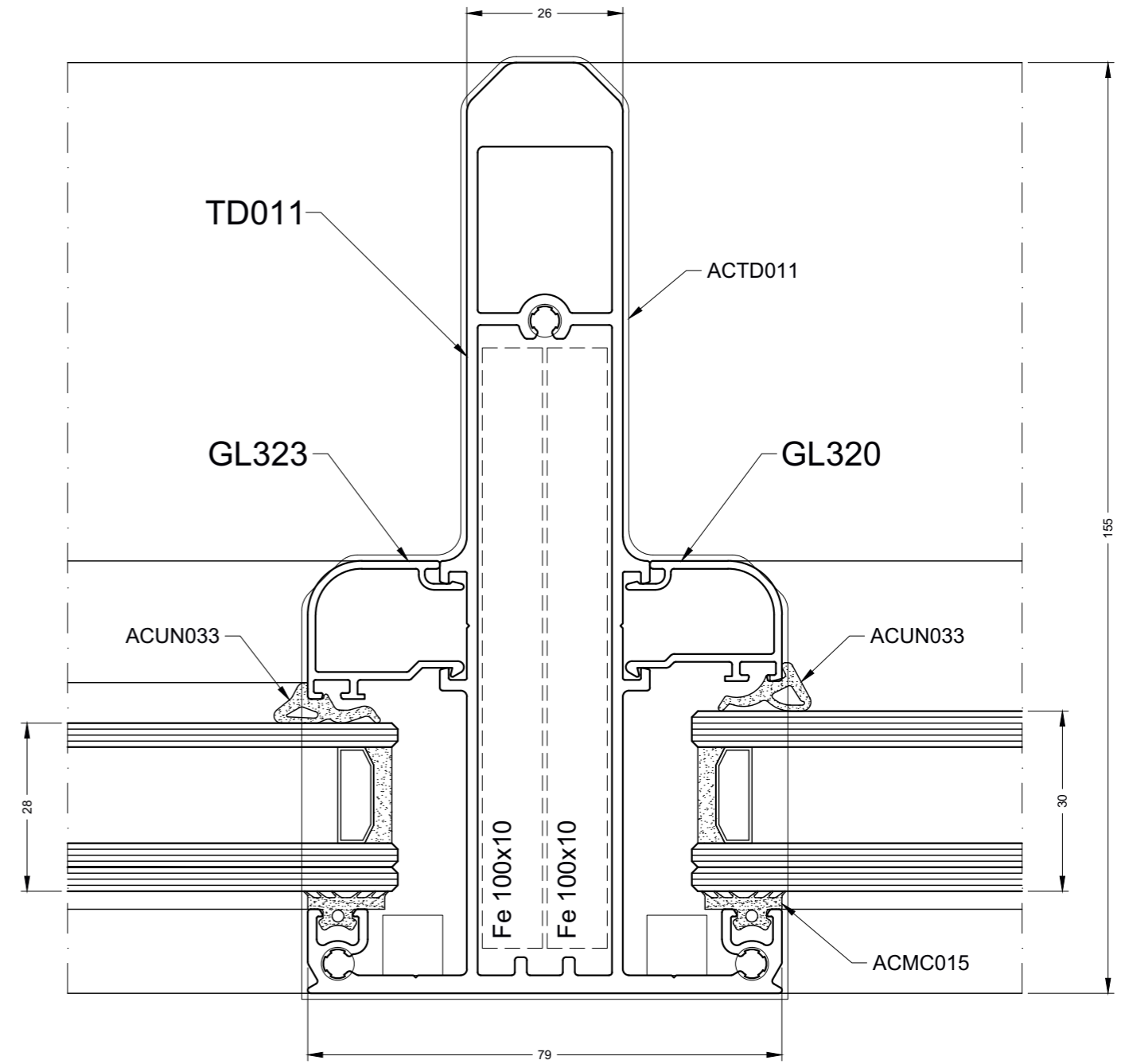
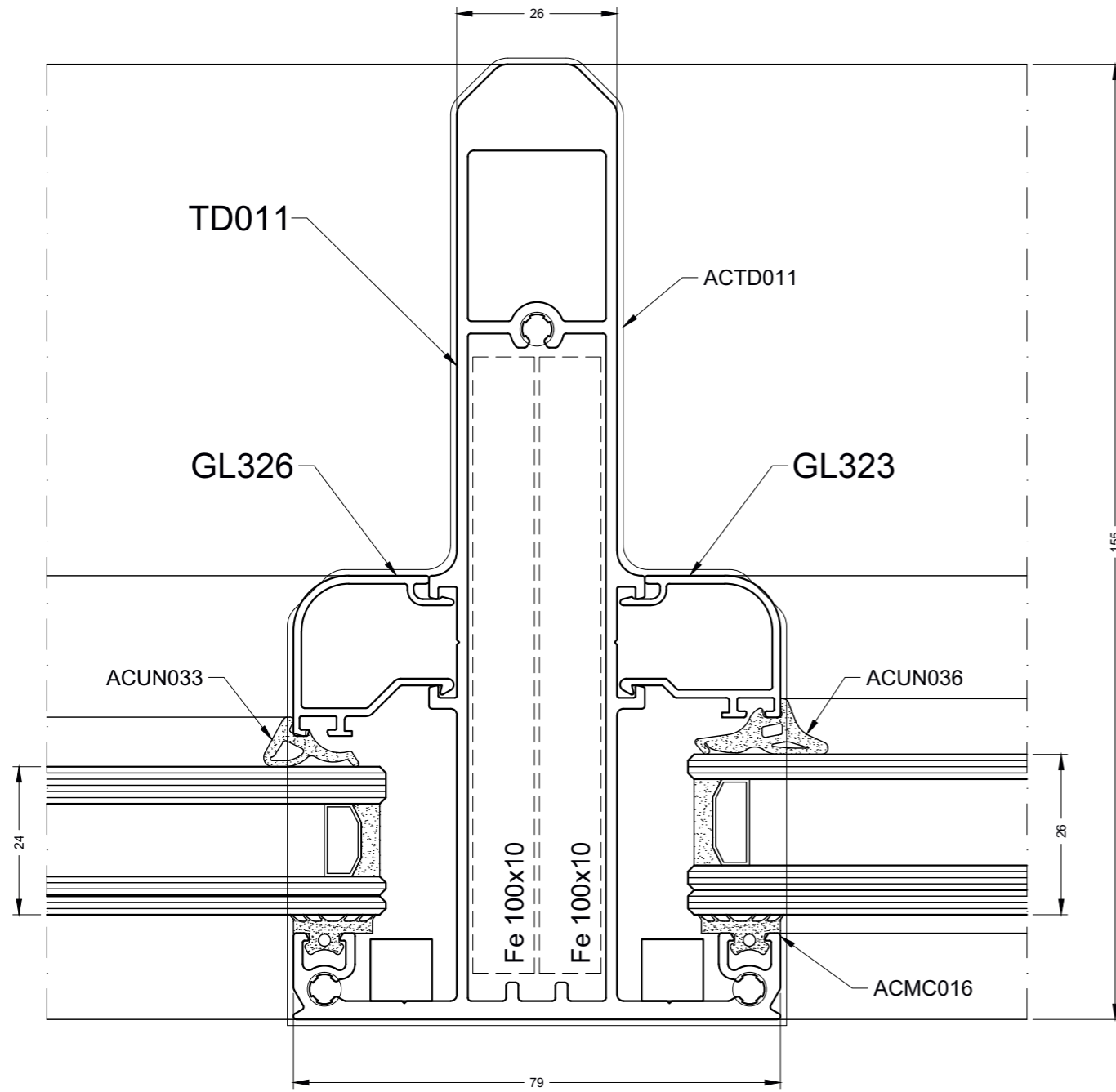

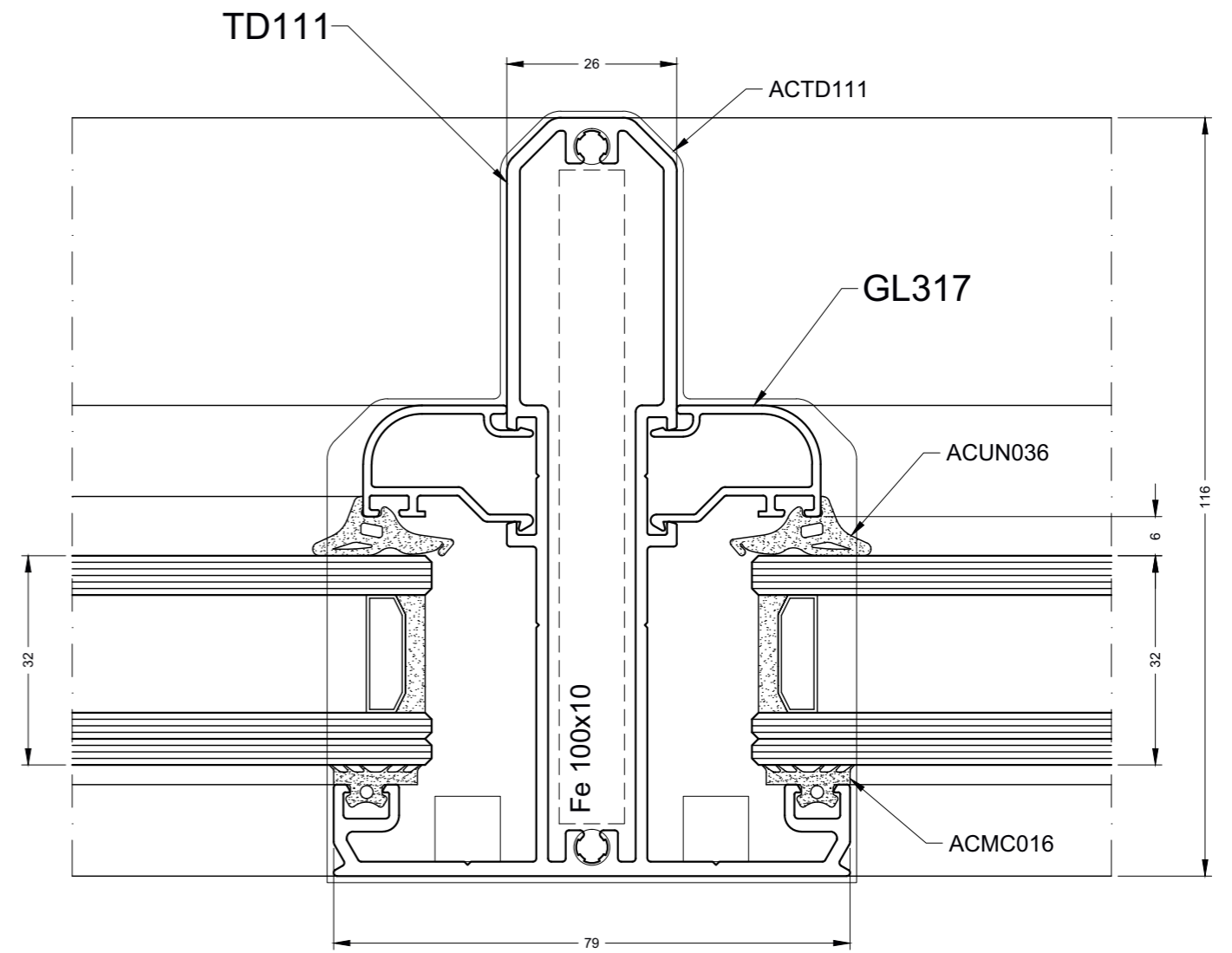
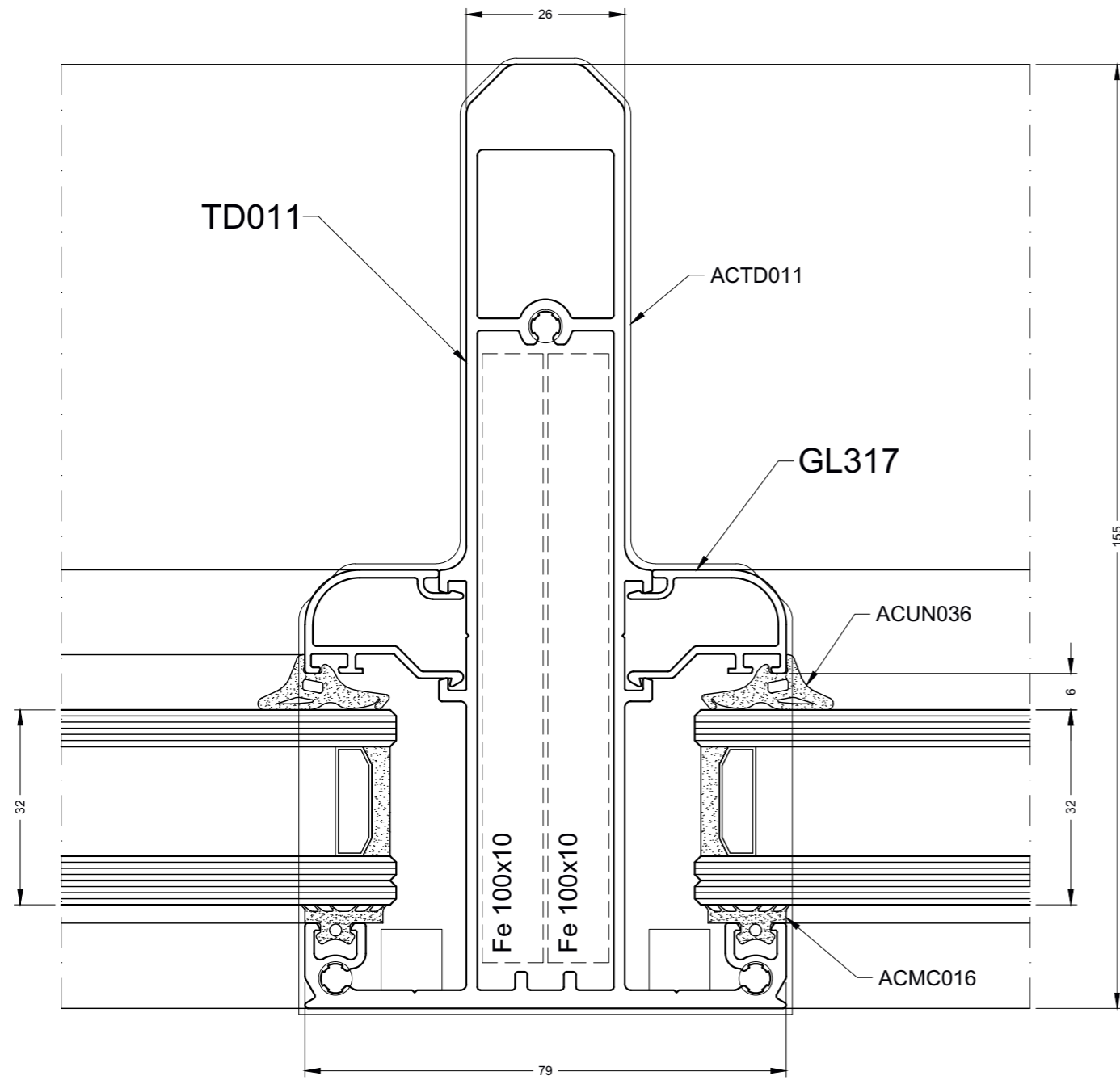

TD011\_007



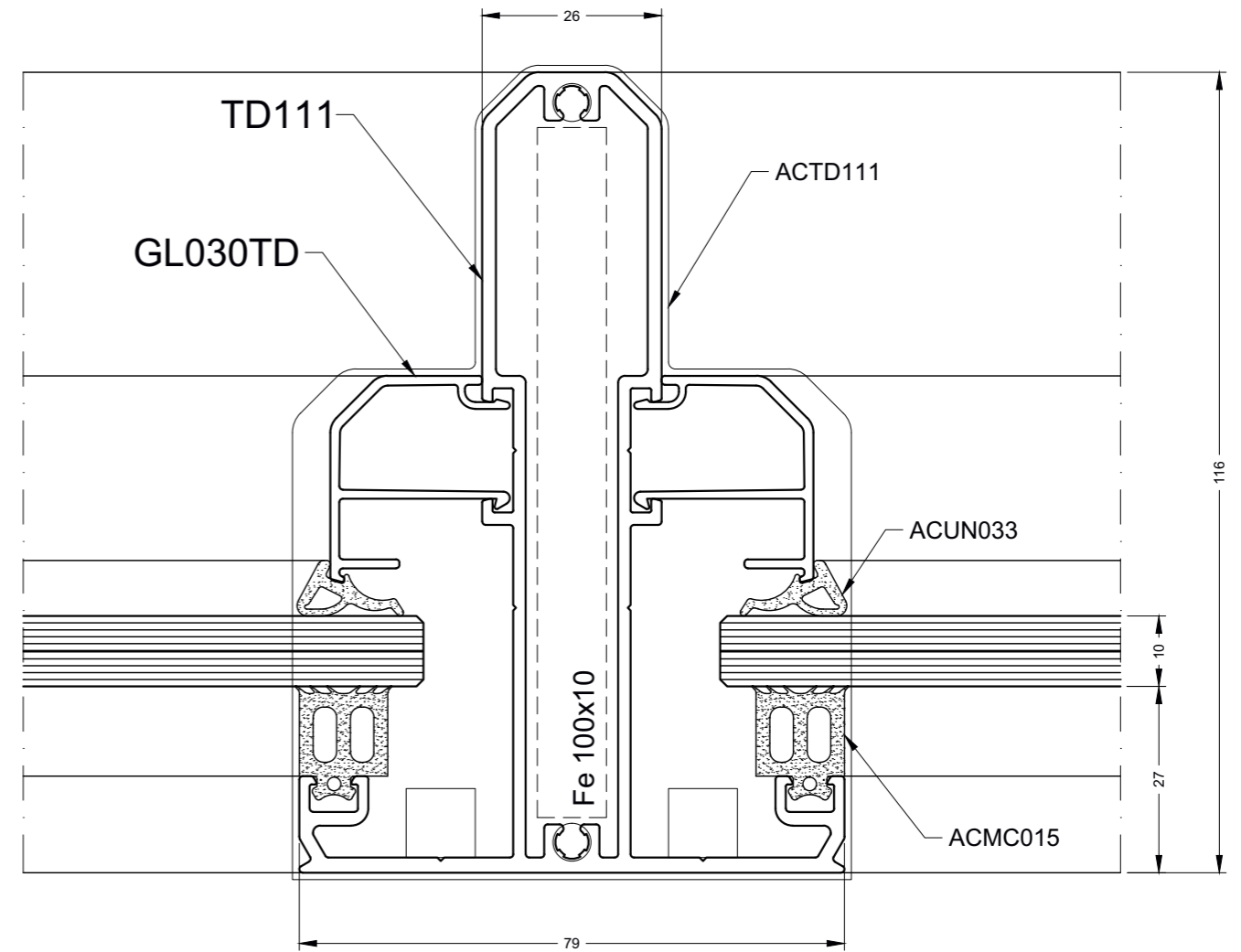
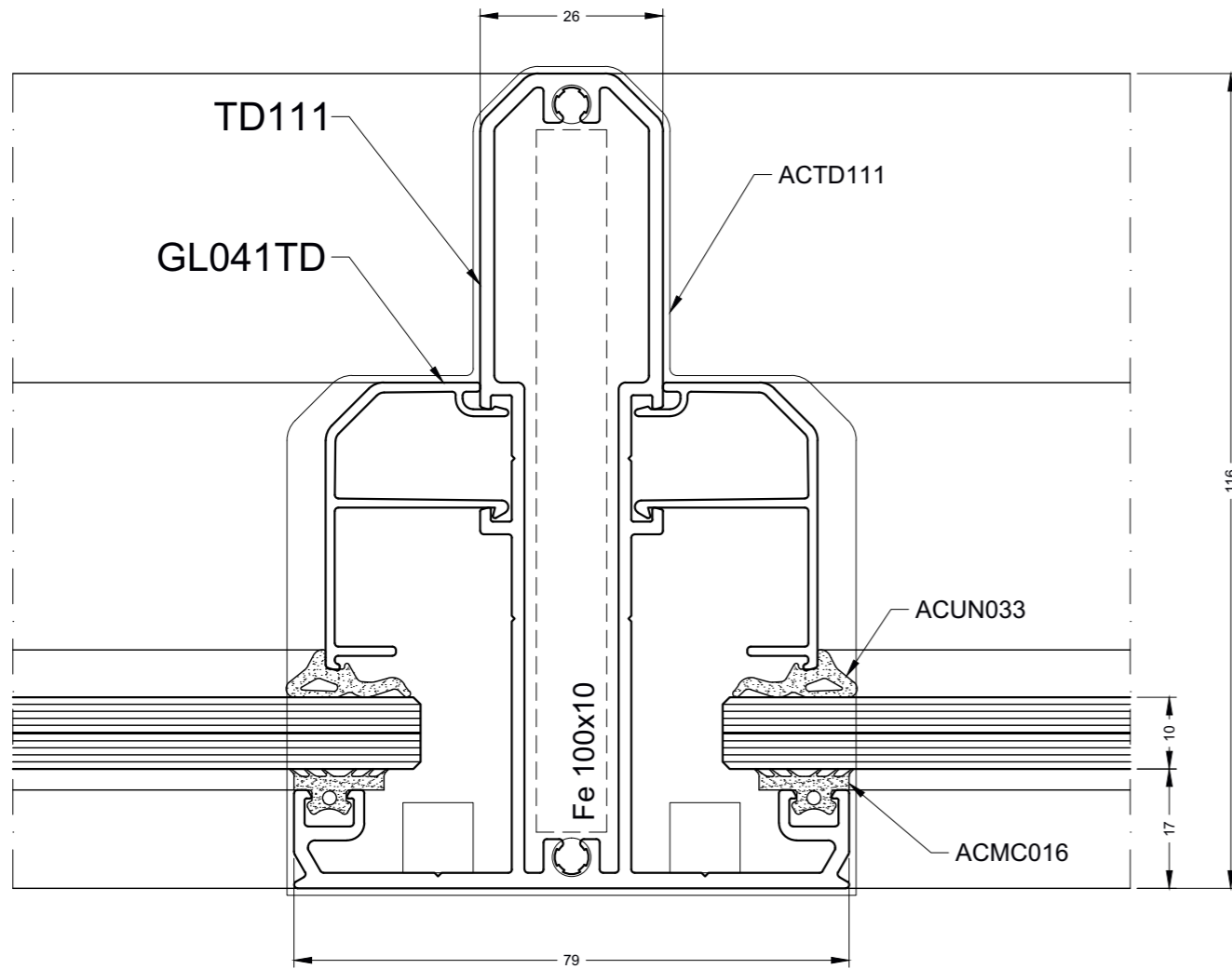

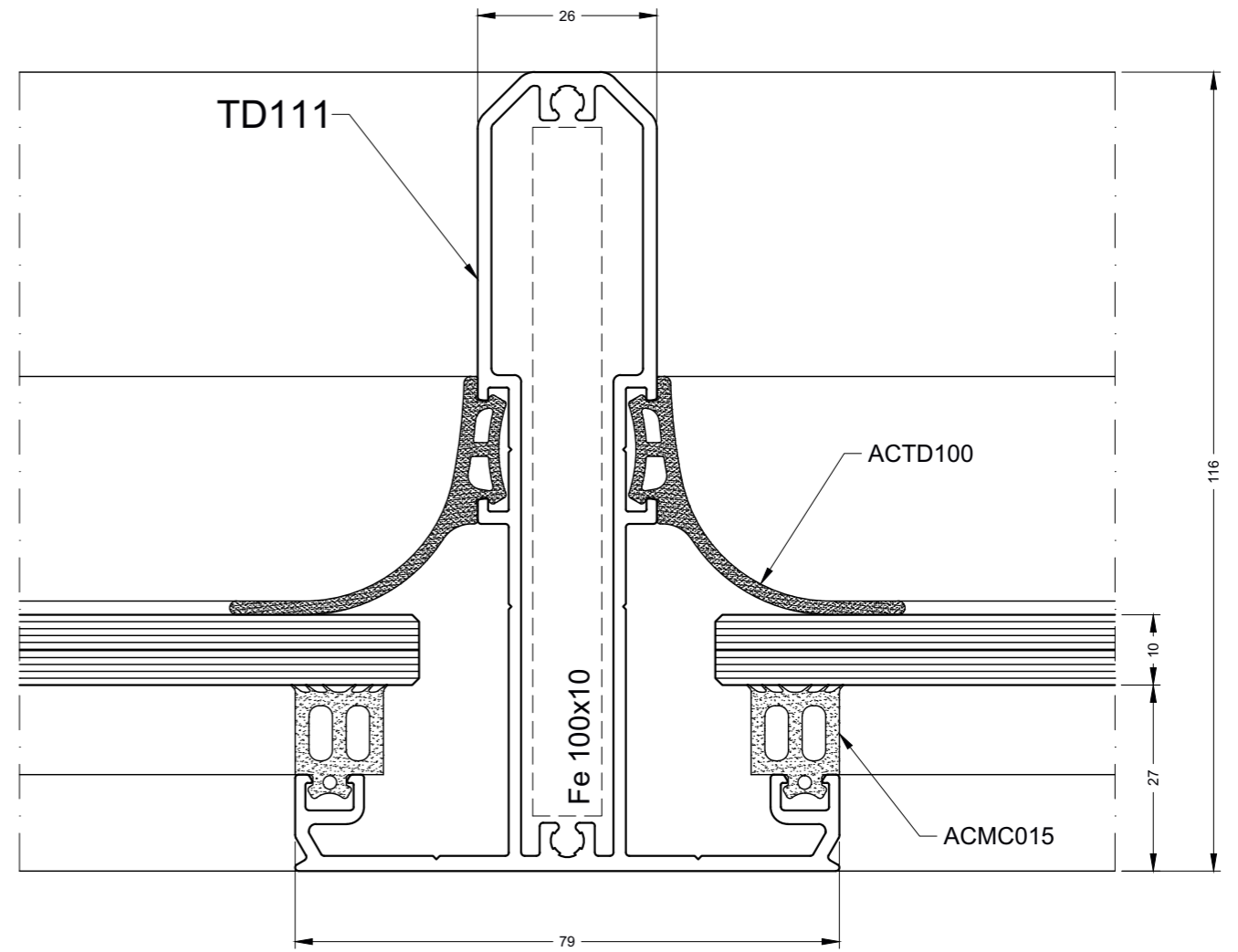
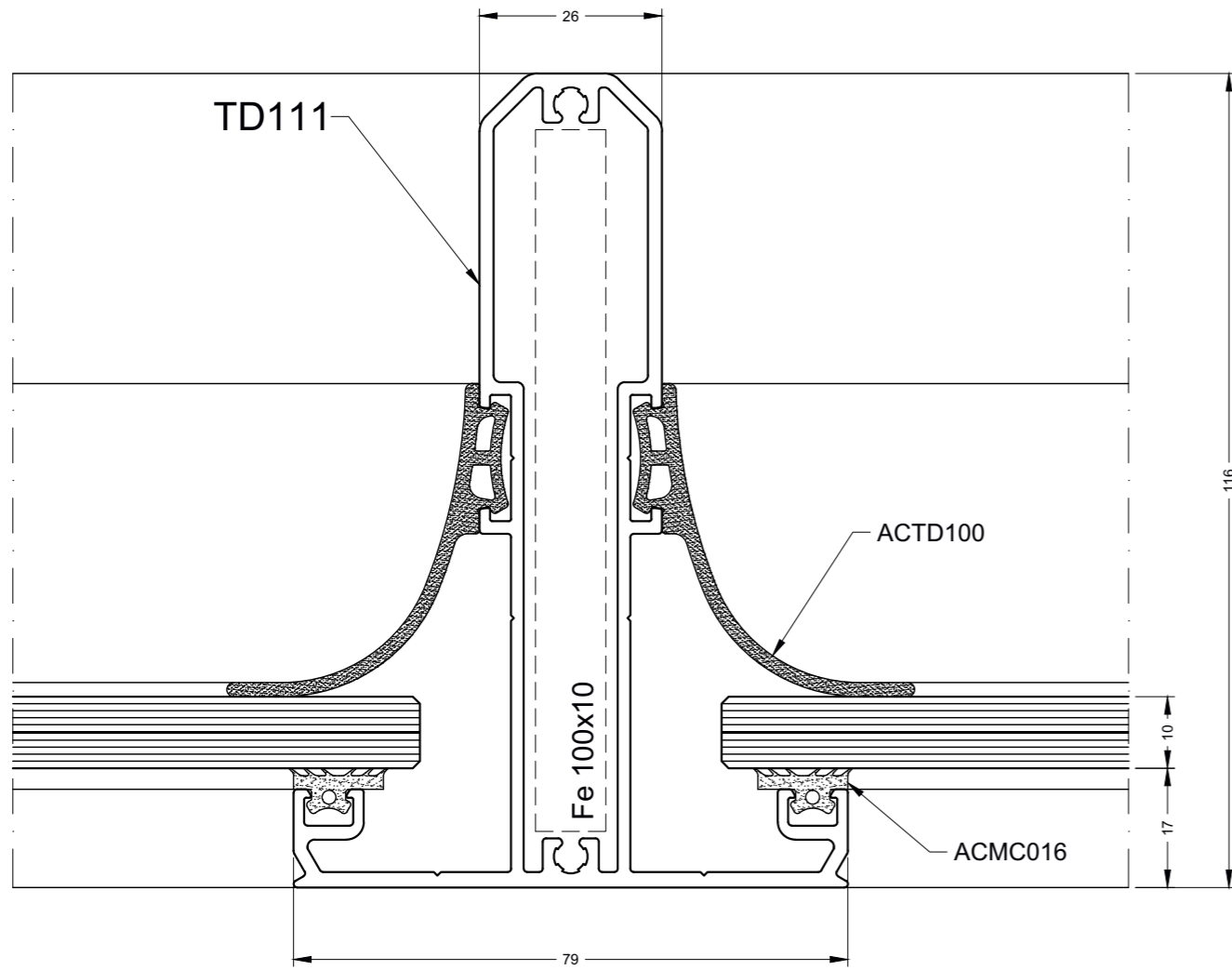

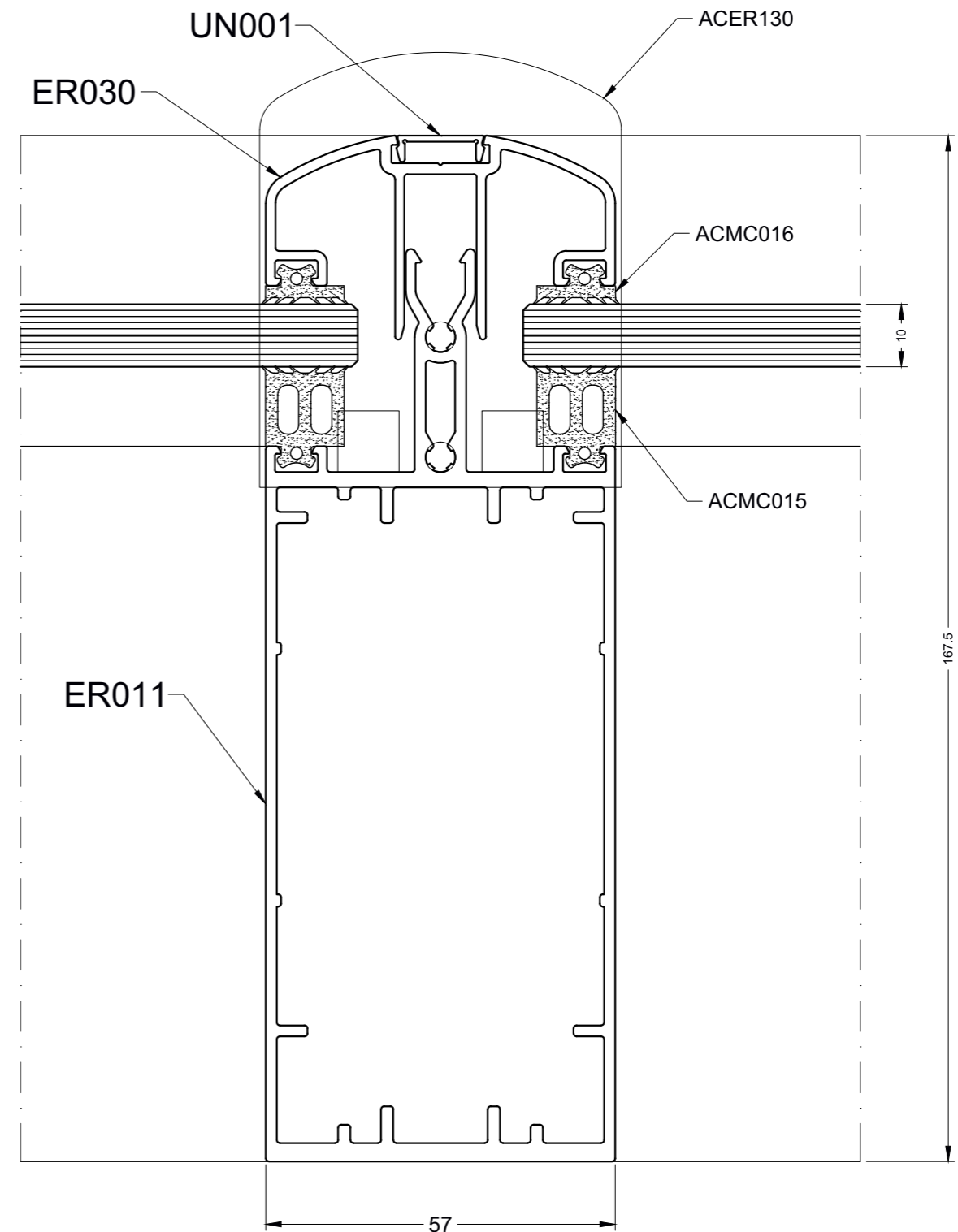
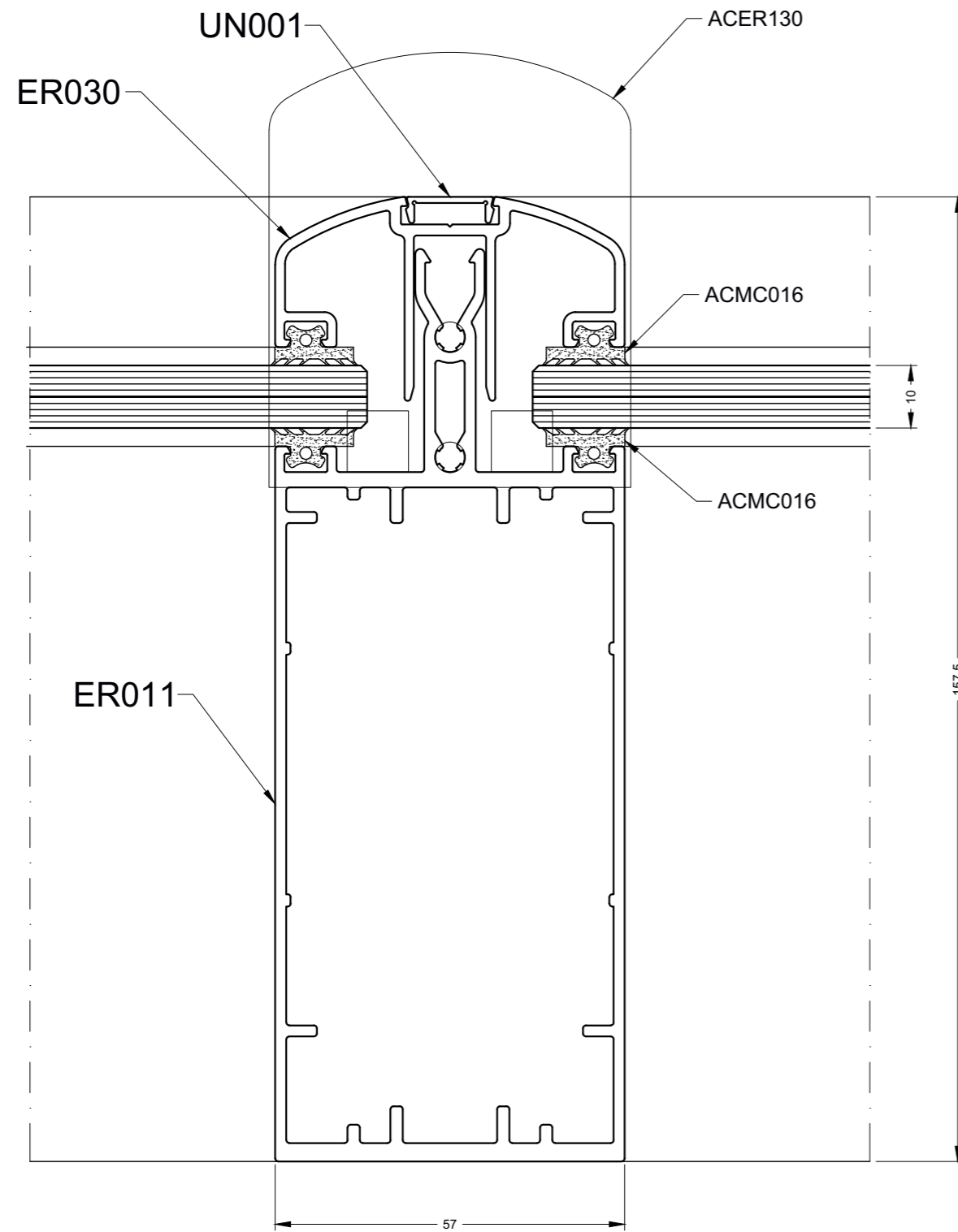

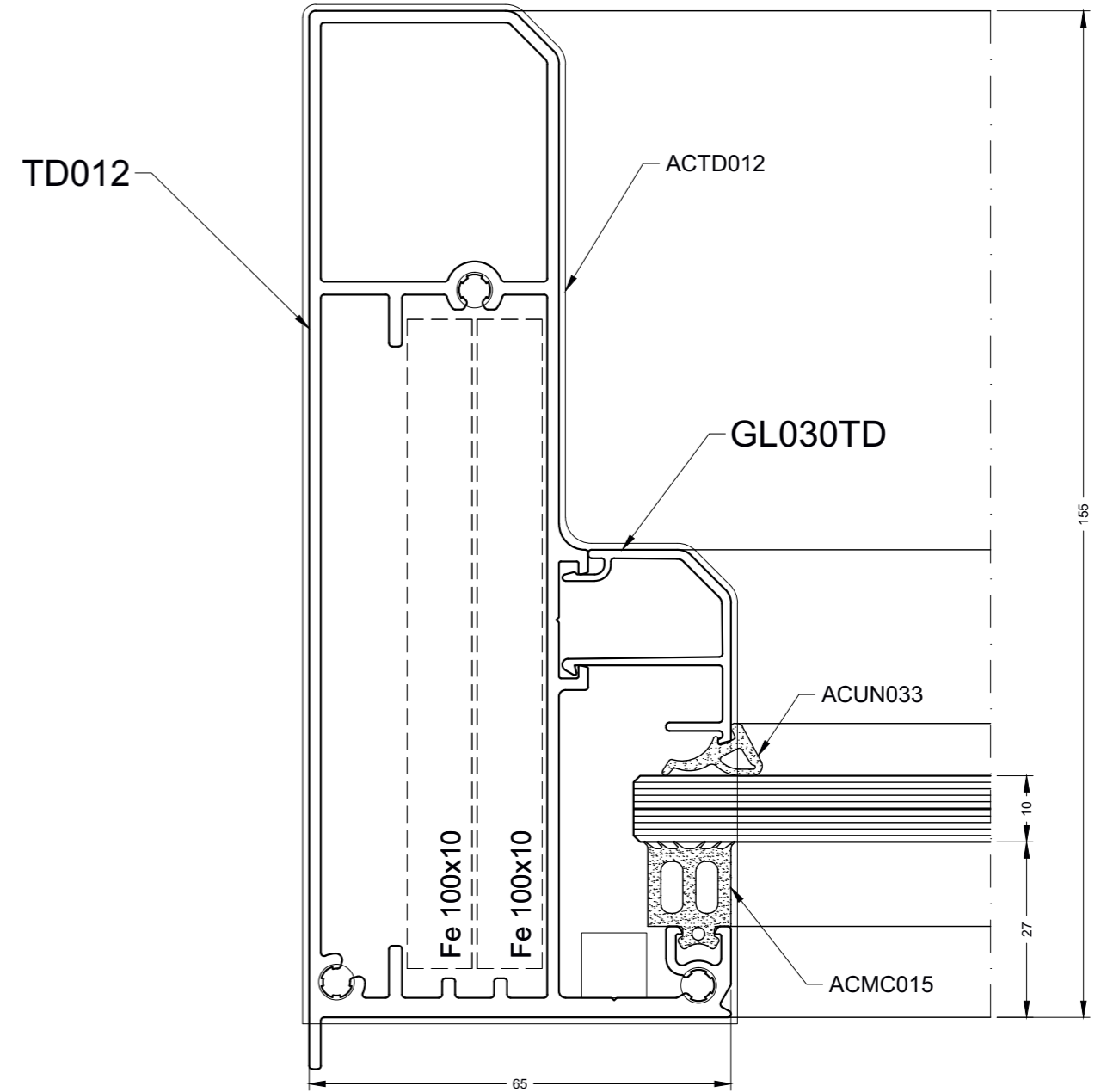
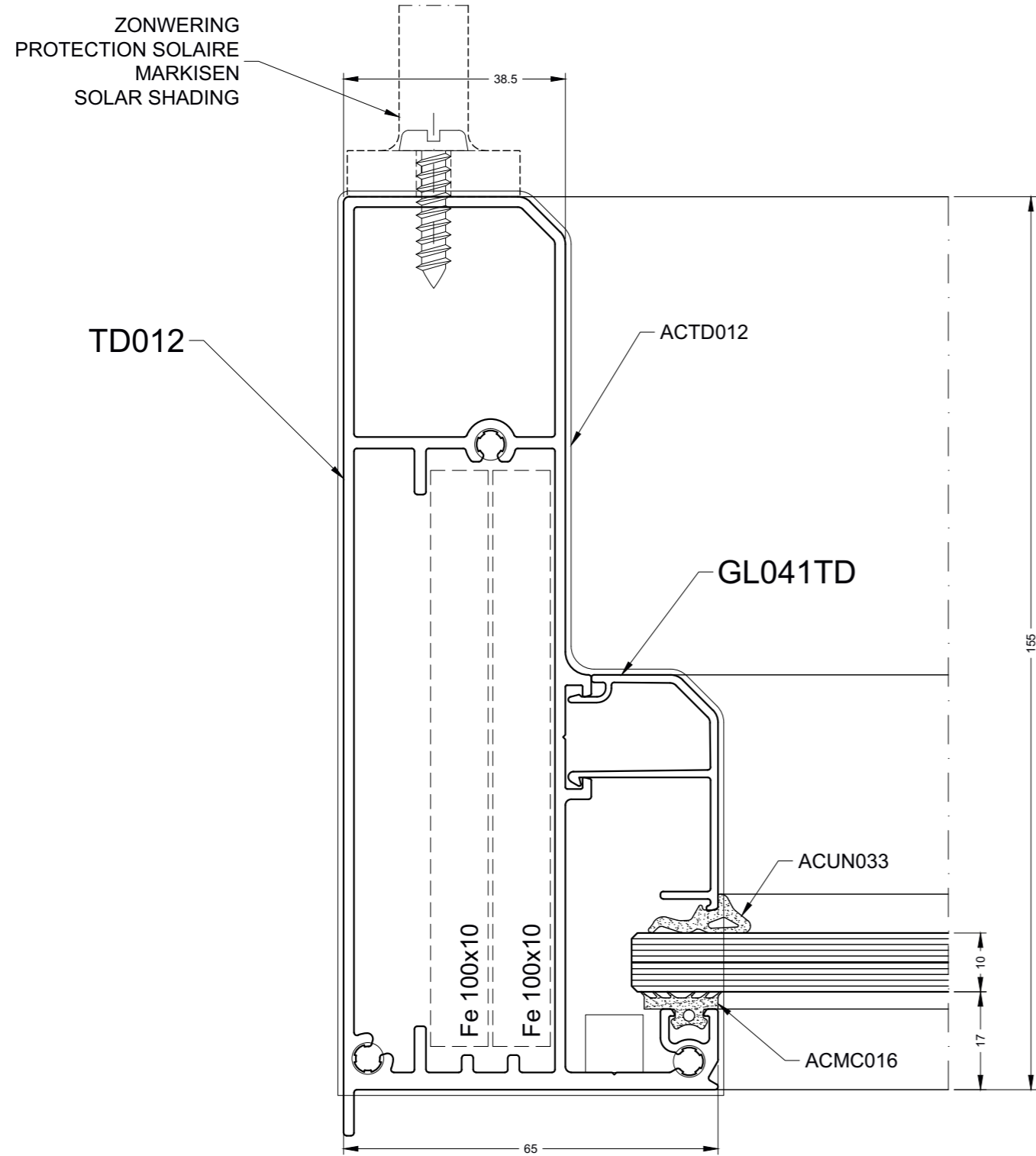

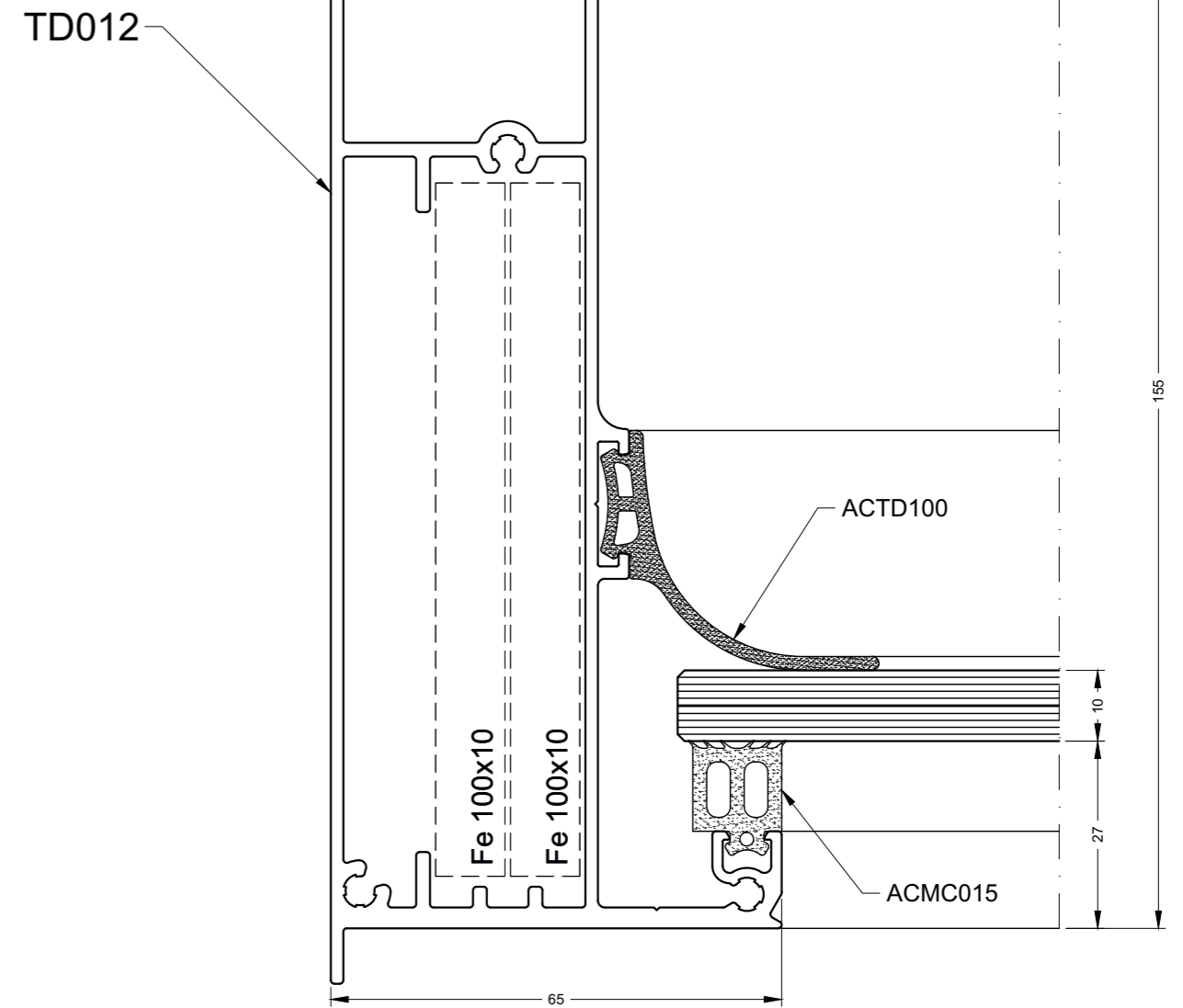
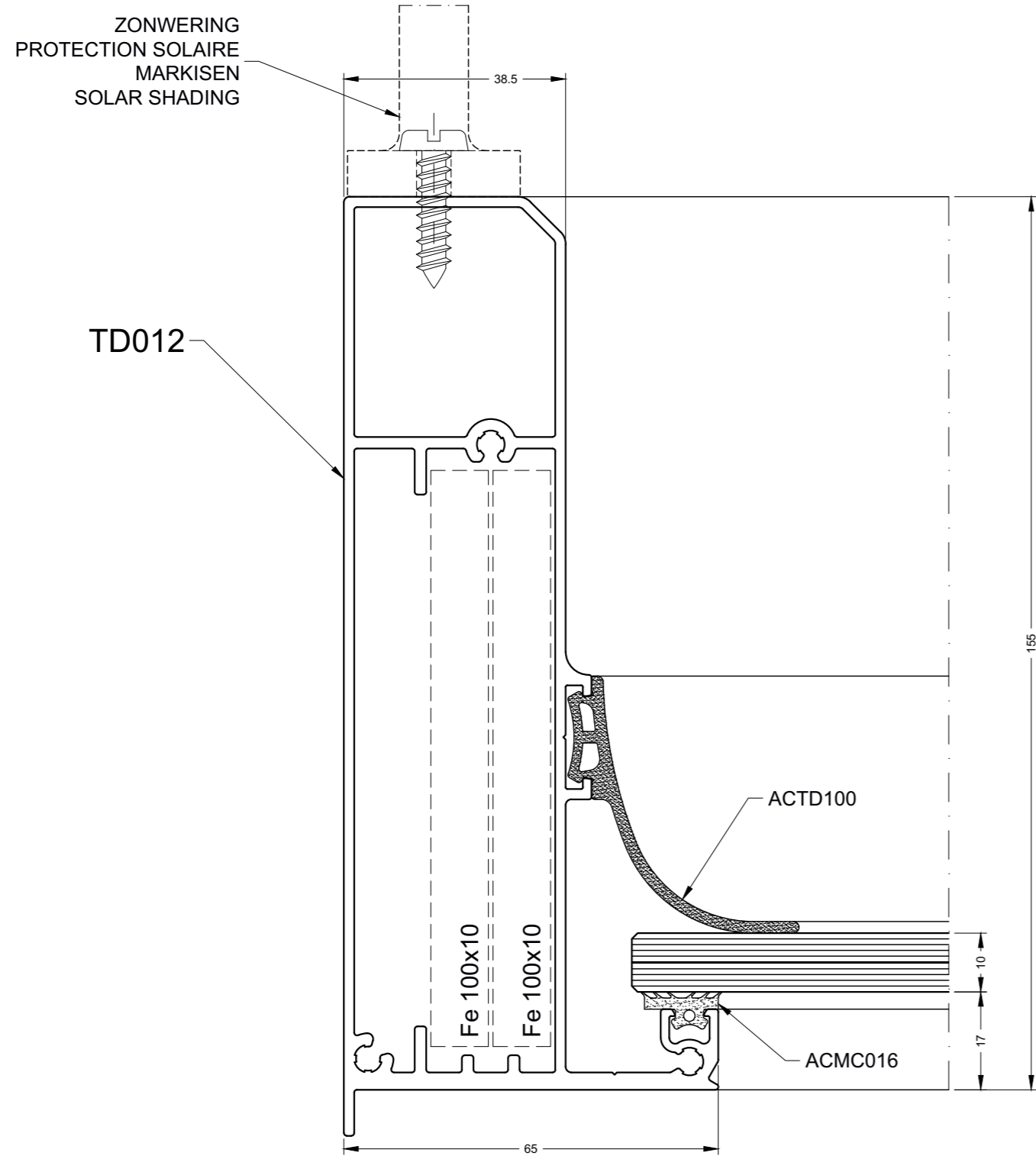

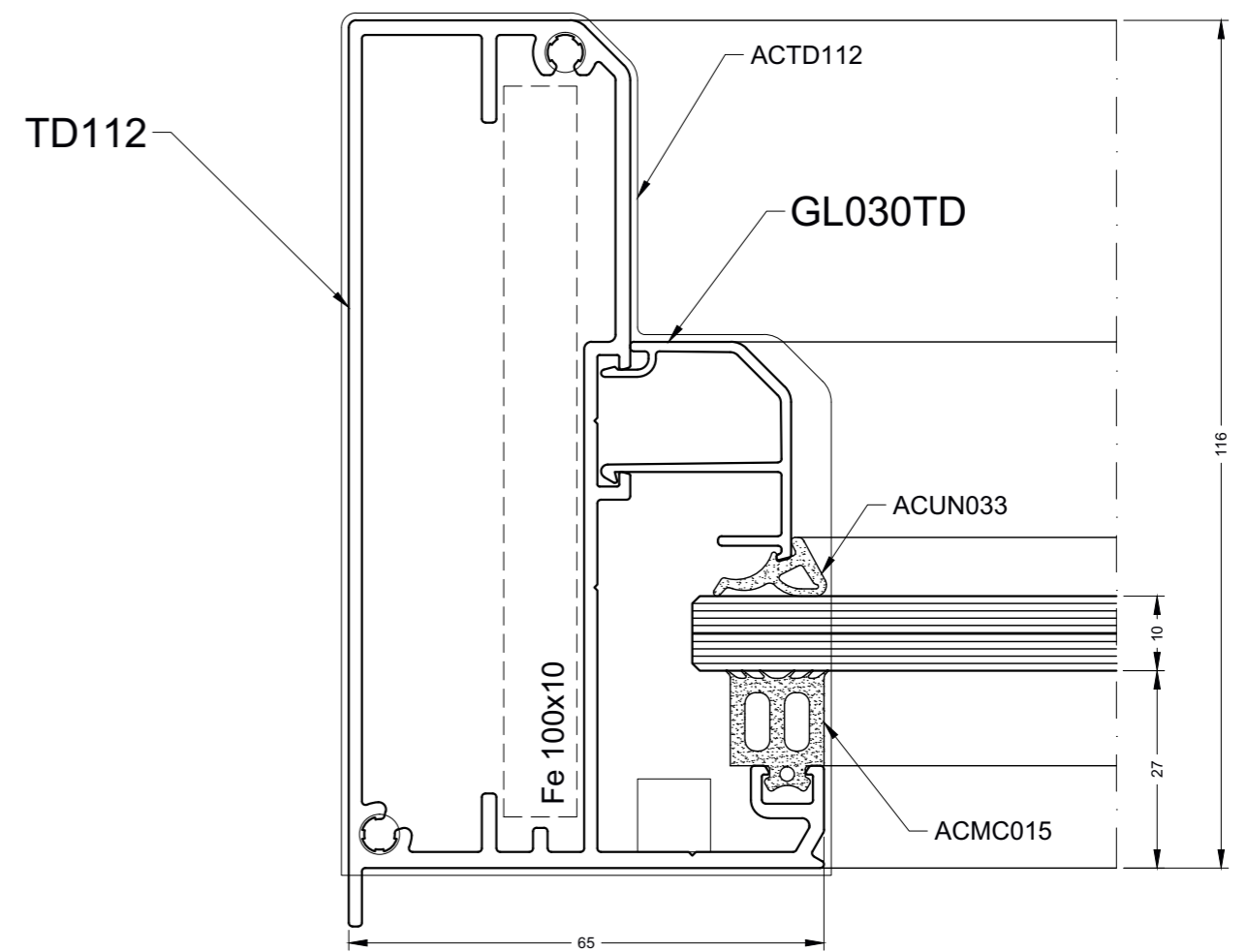
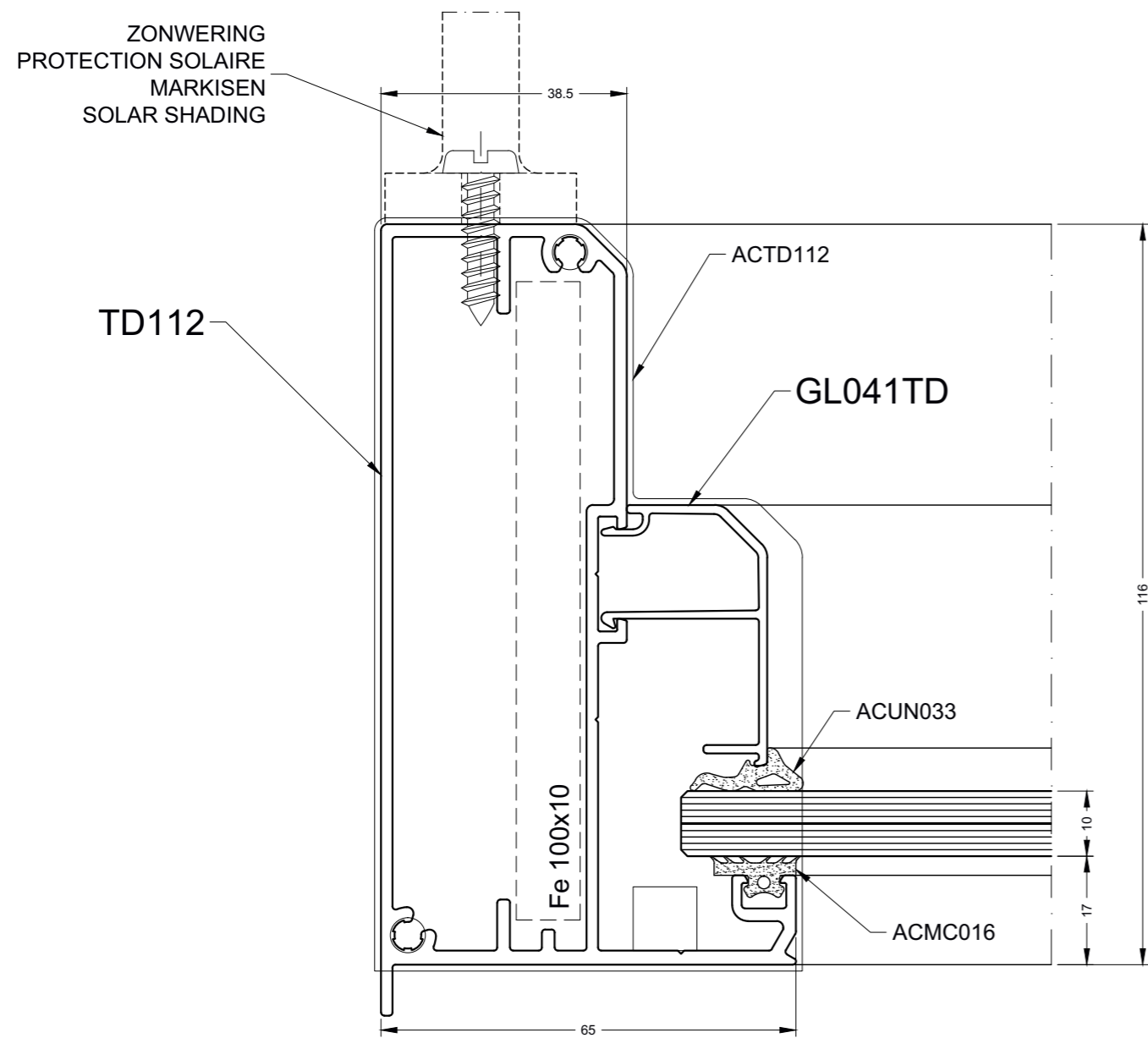

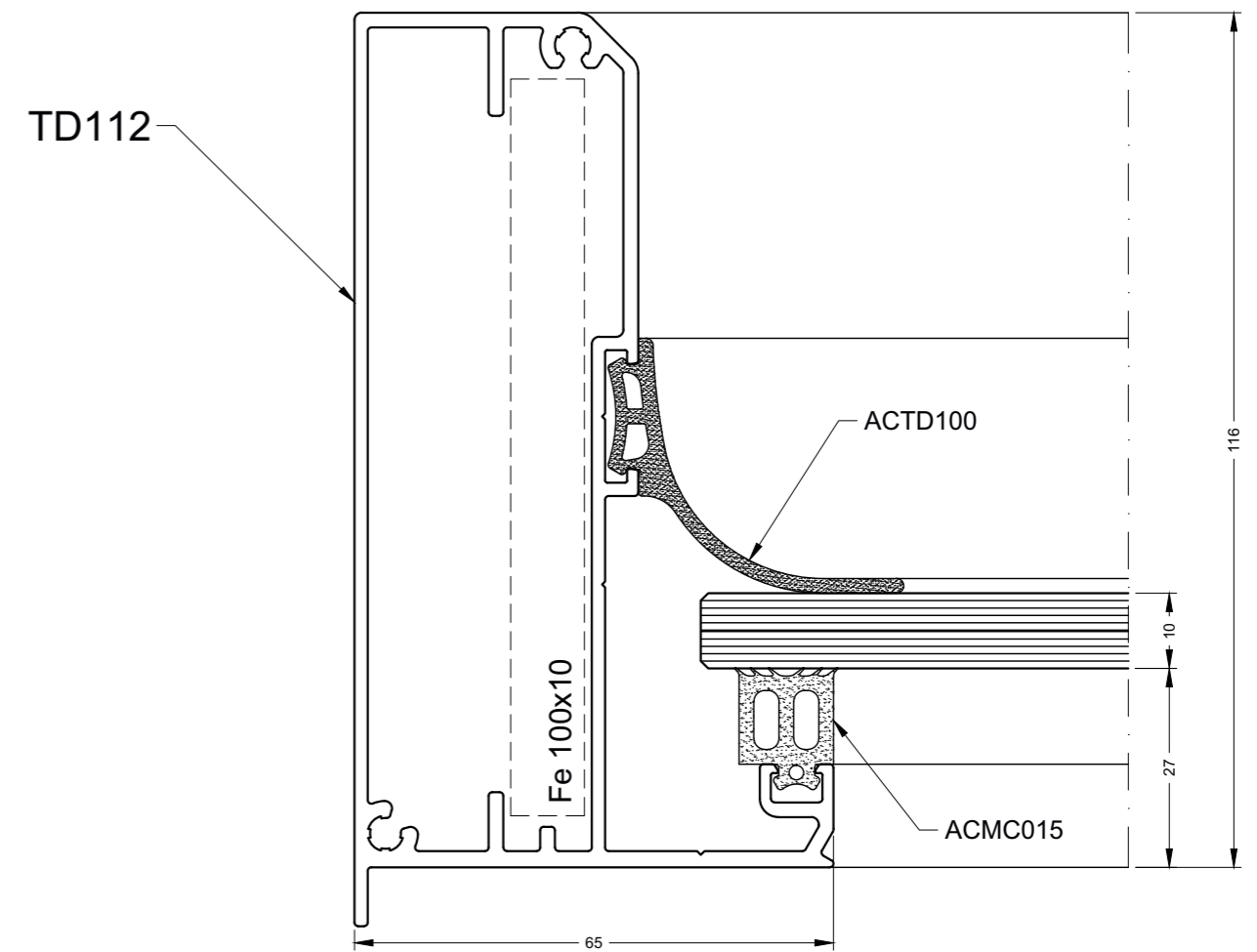
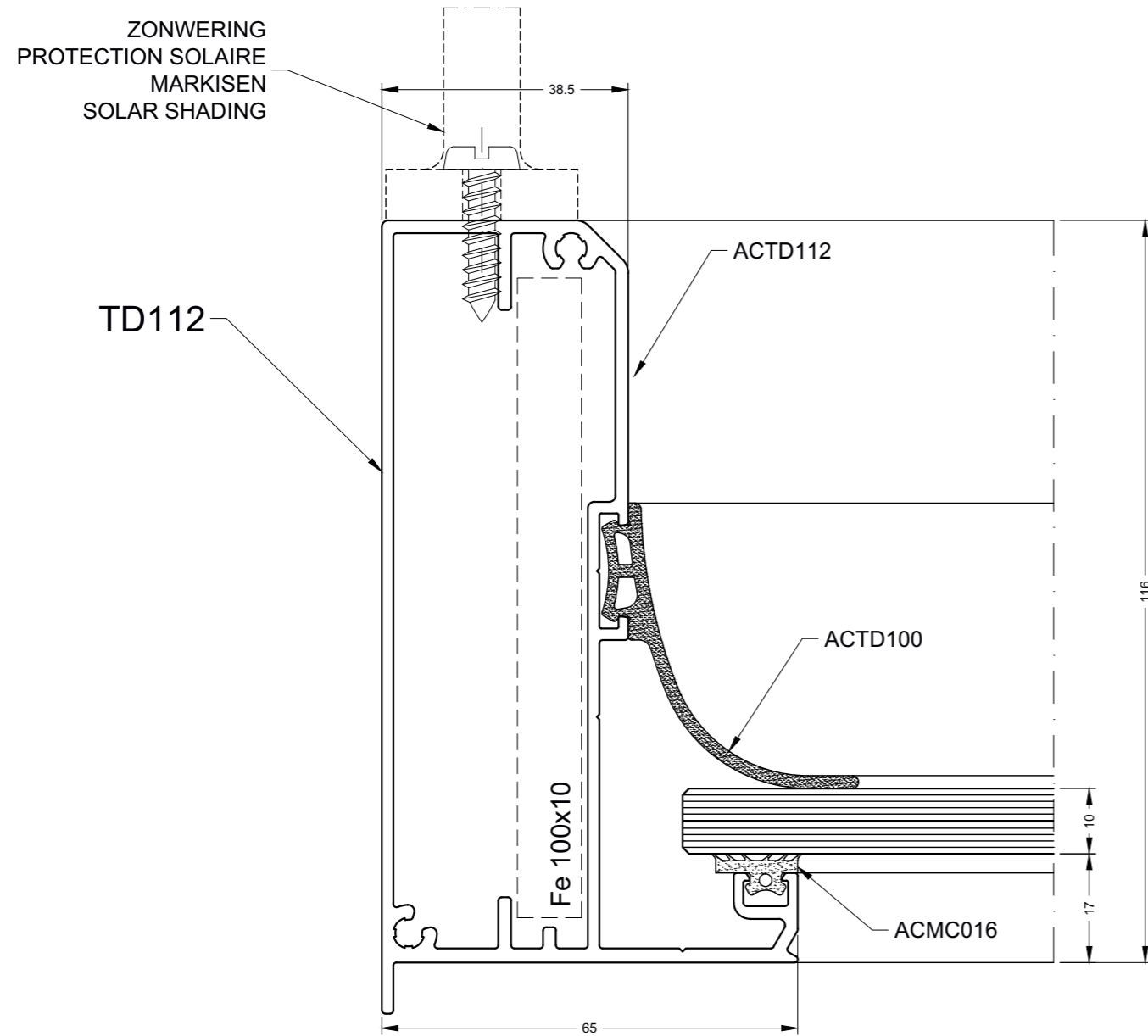

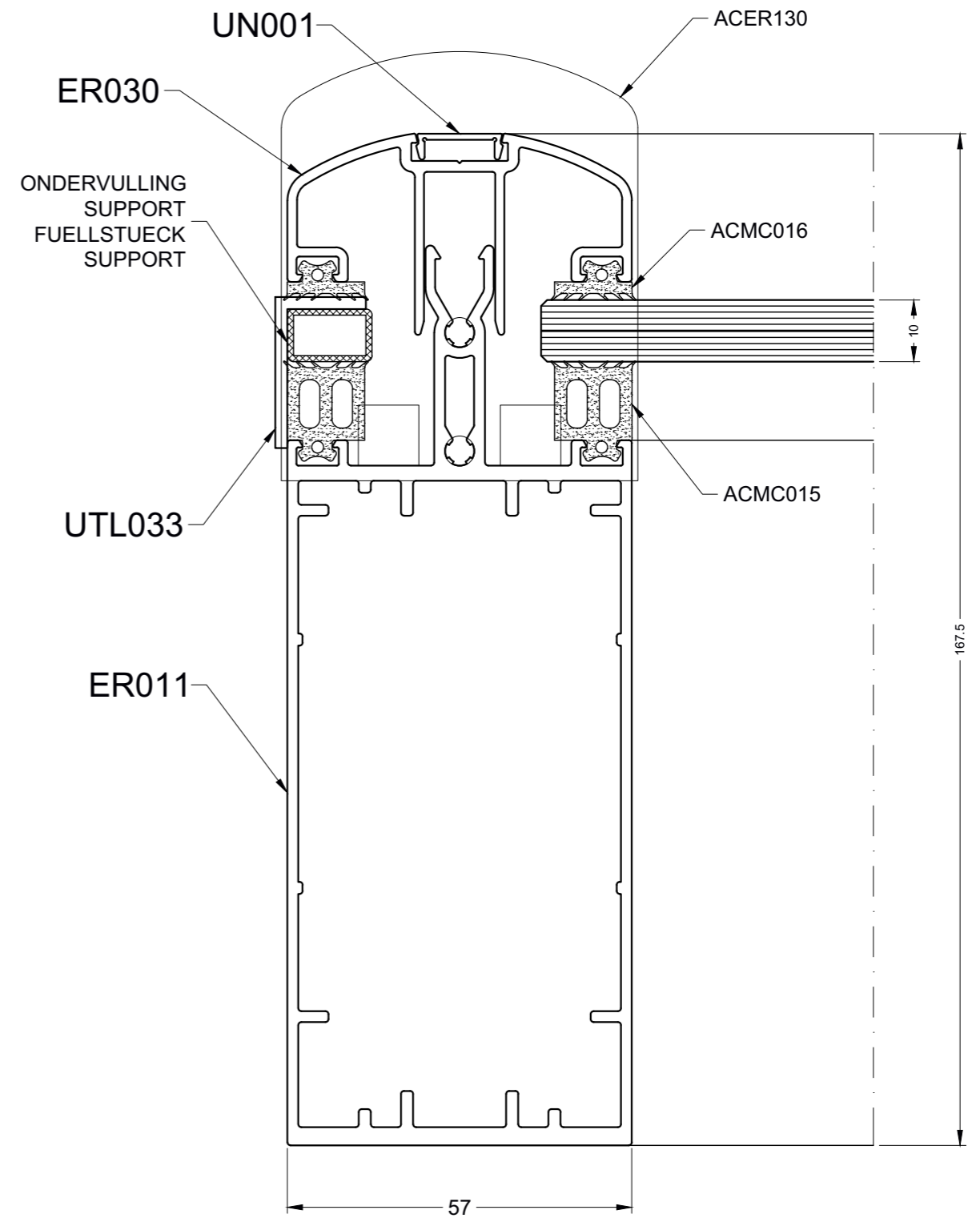
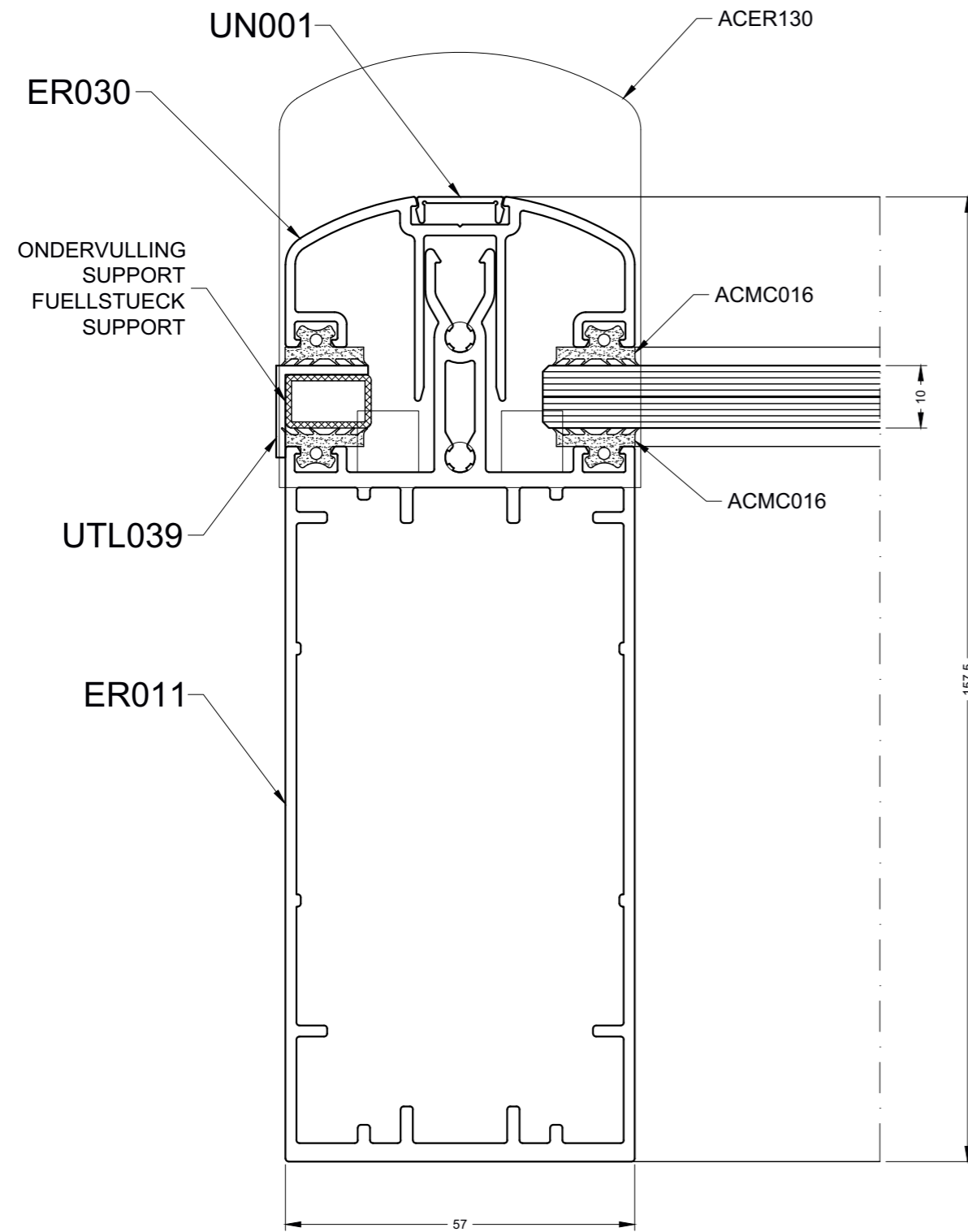



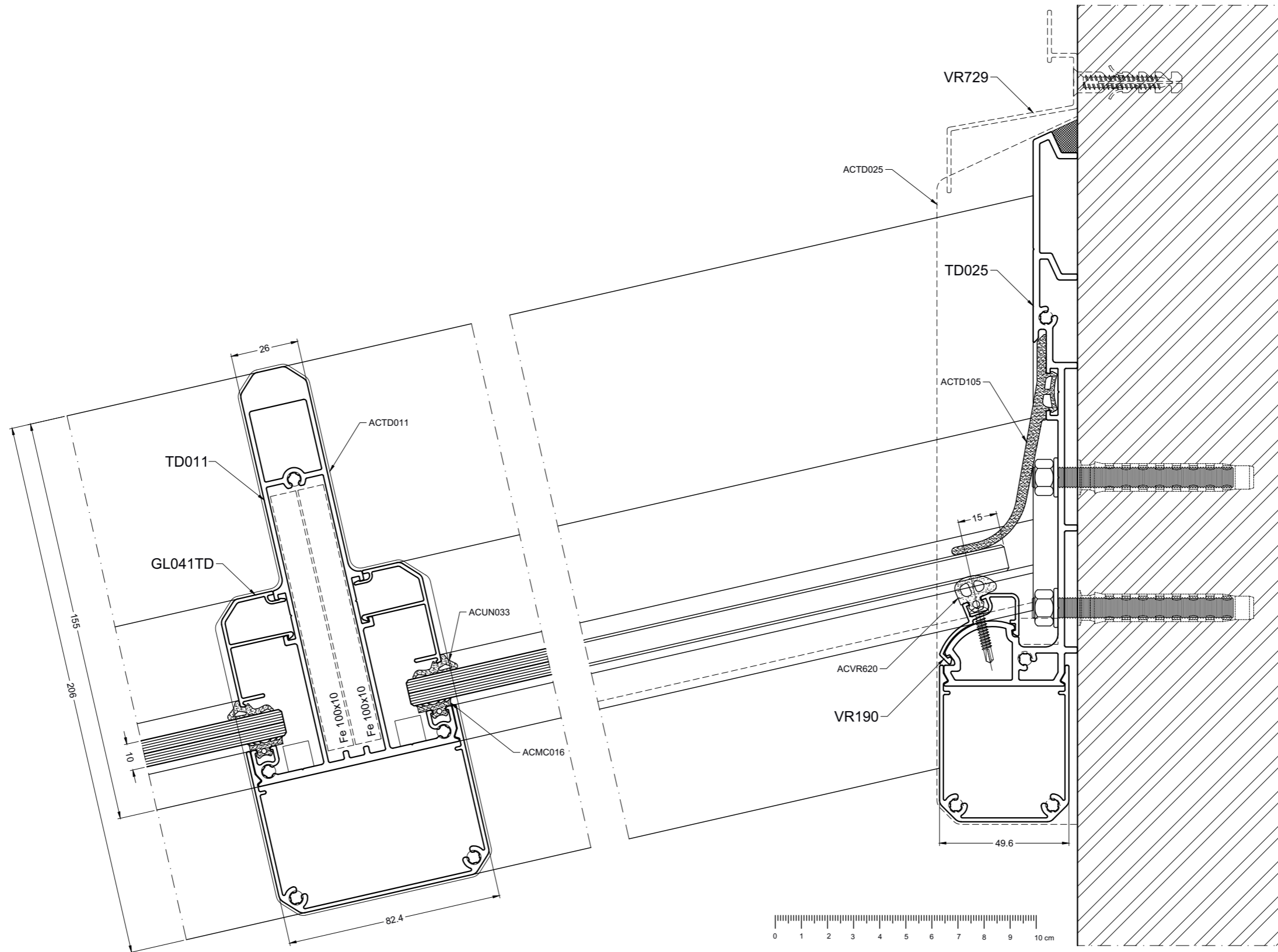

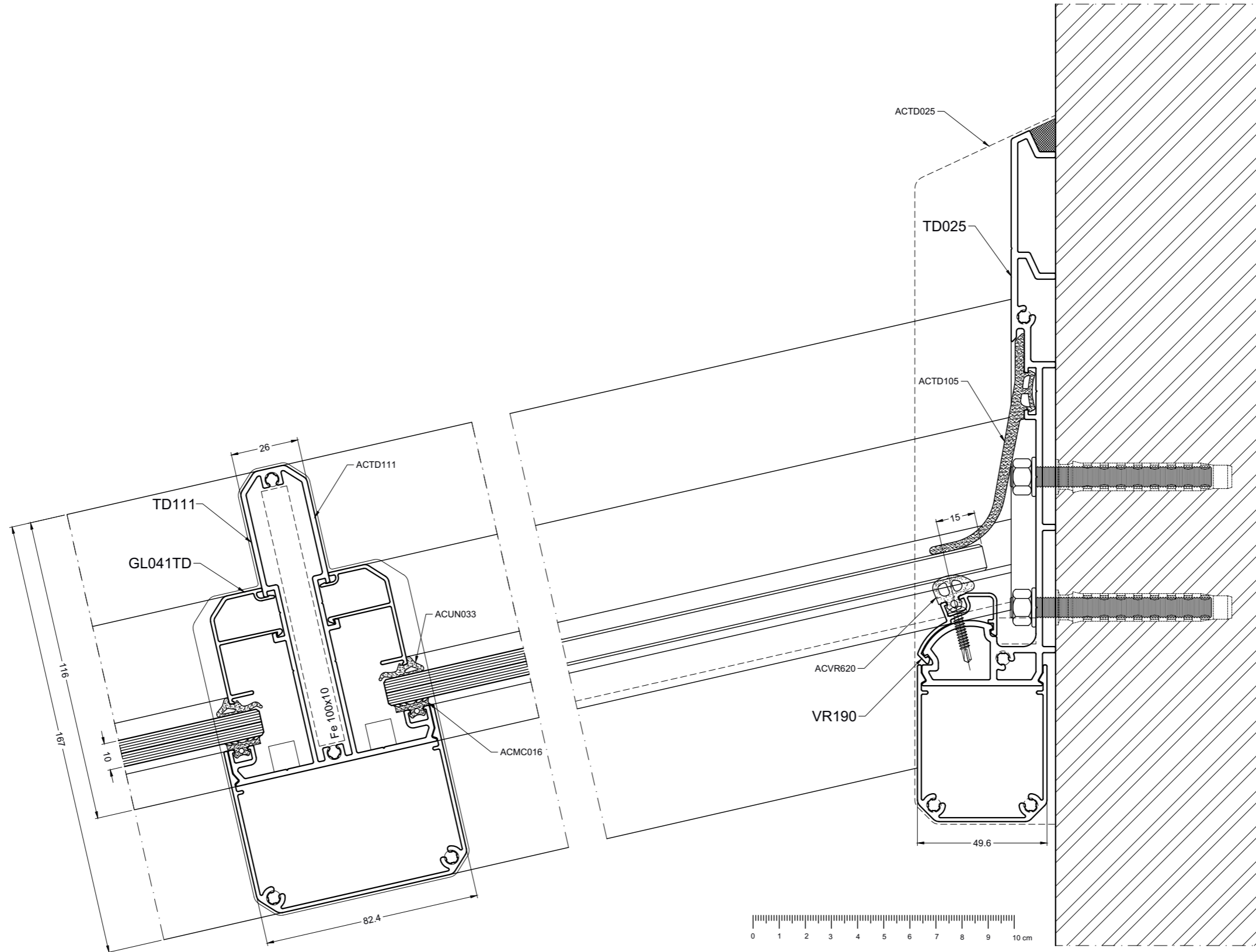

TD025\_002

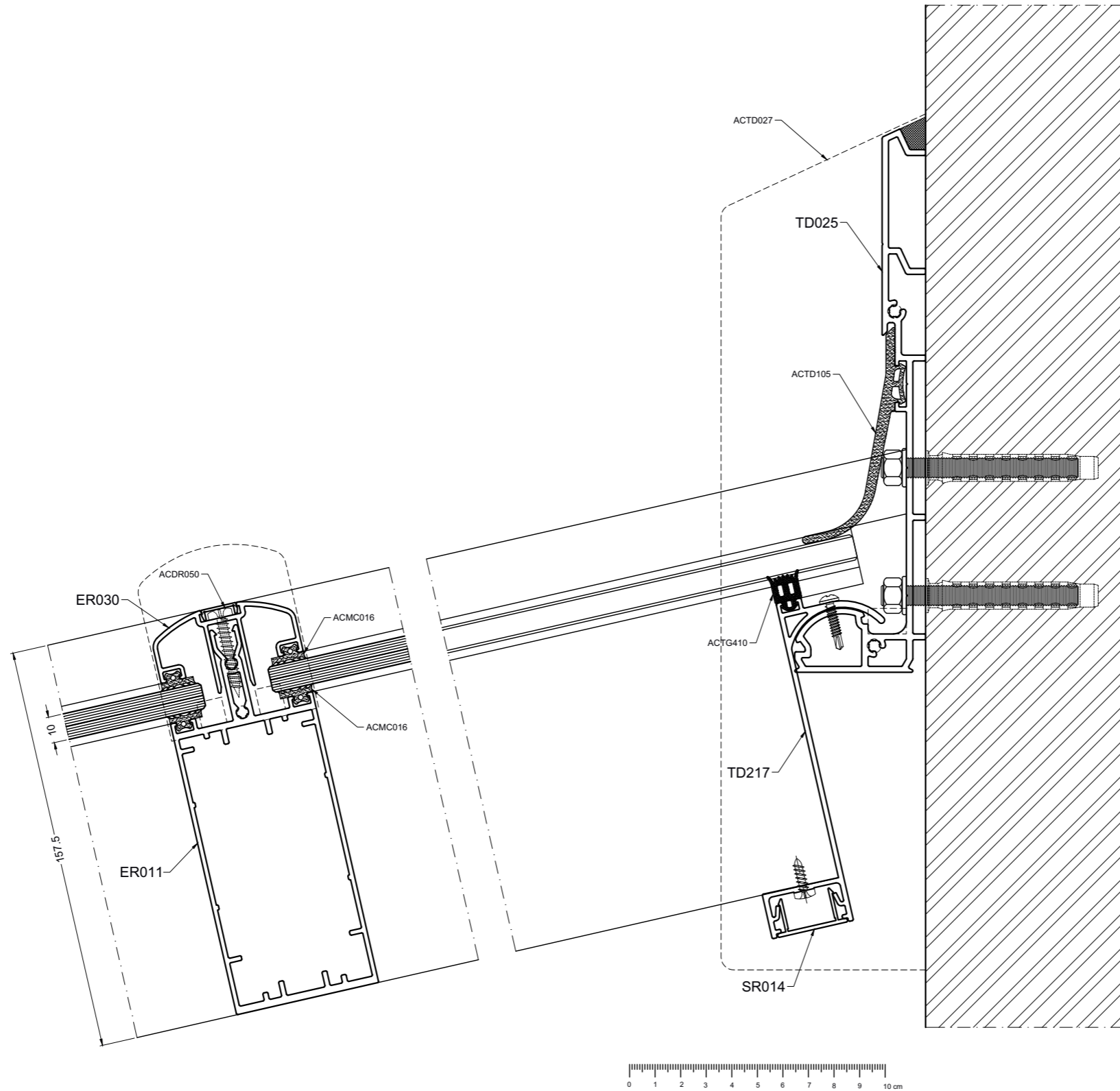

TD025\_003

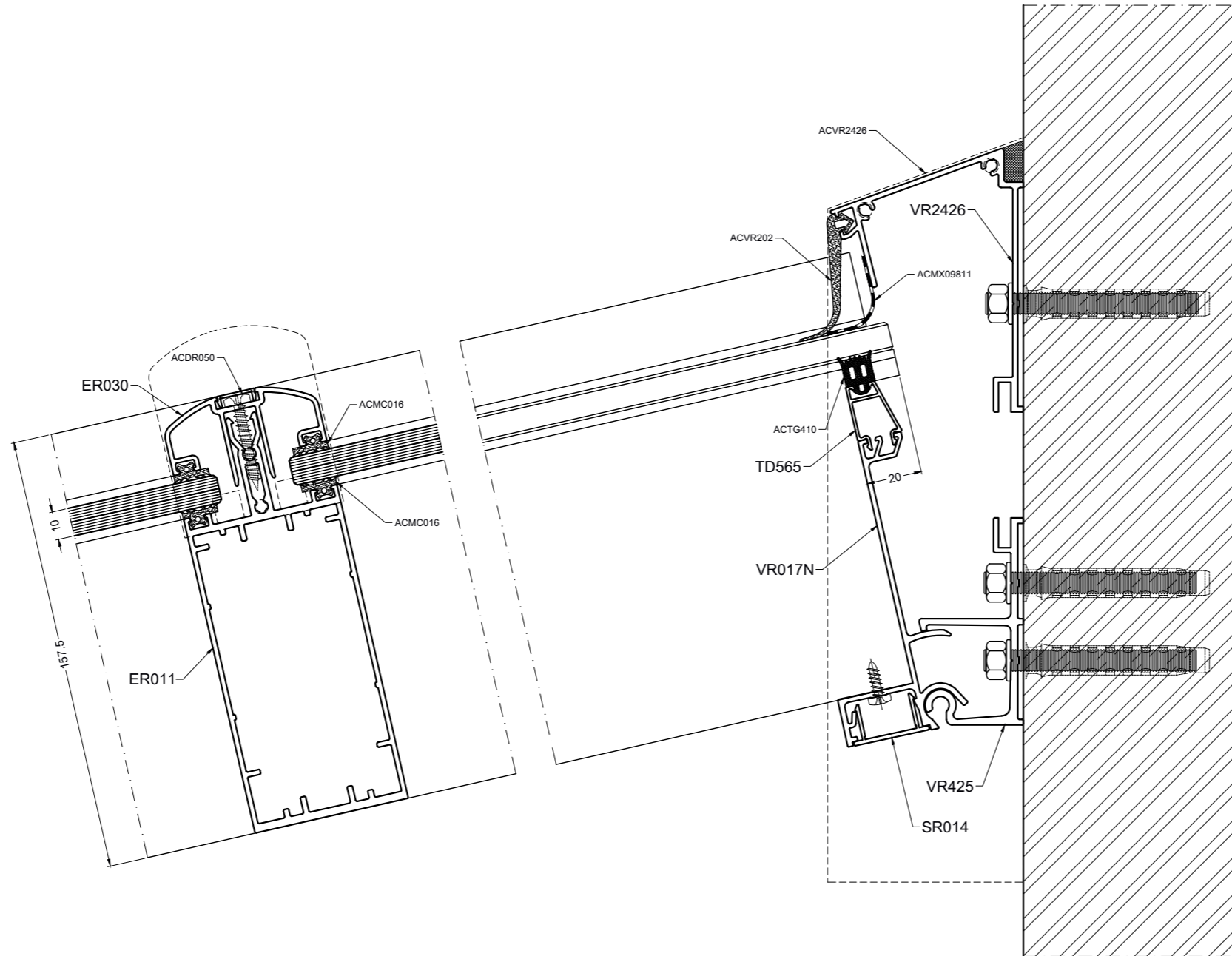

VR425\_001



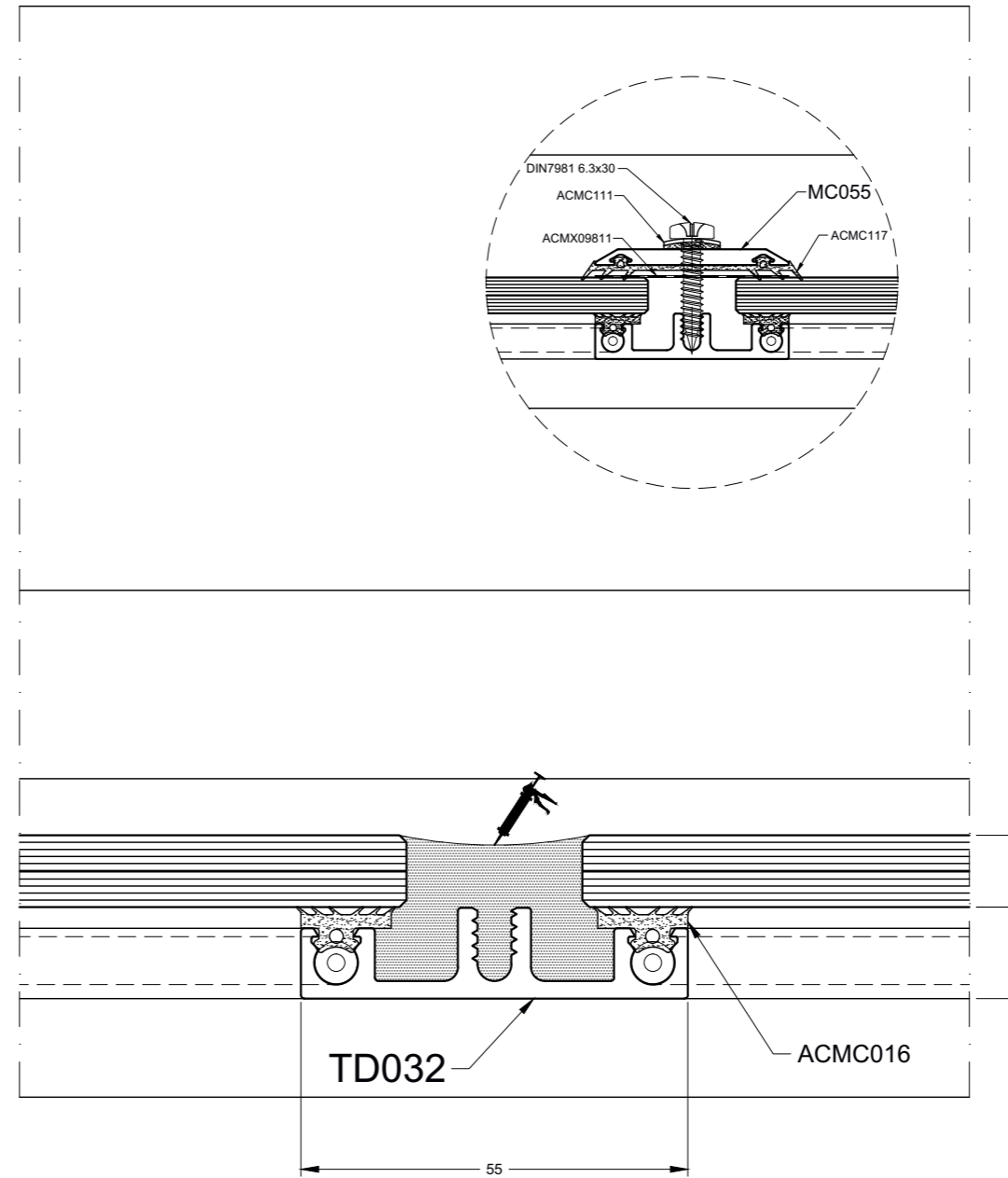
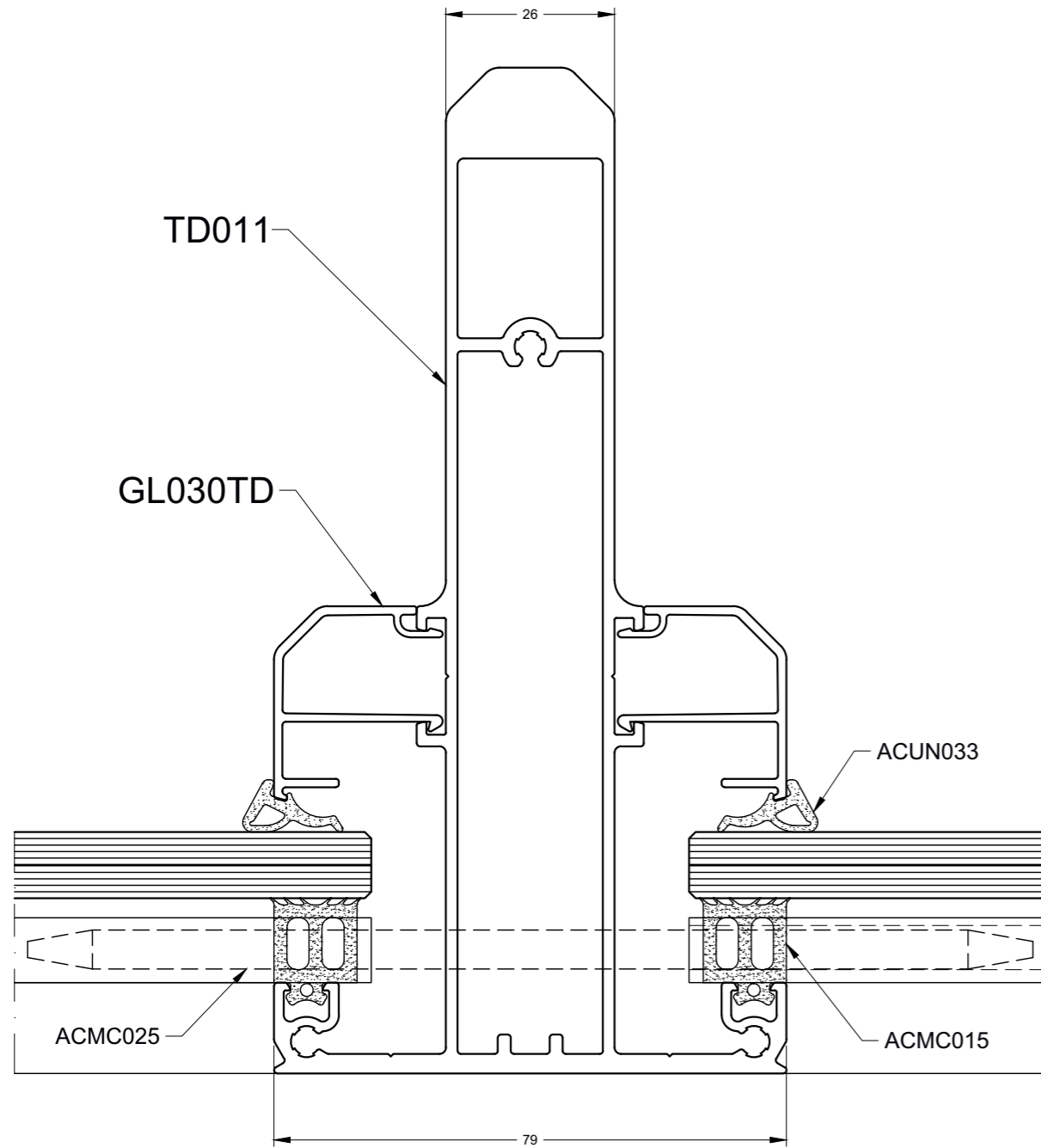

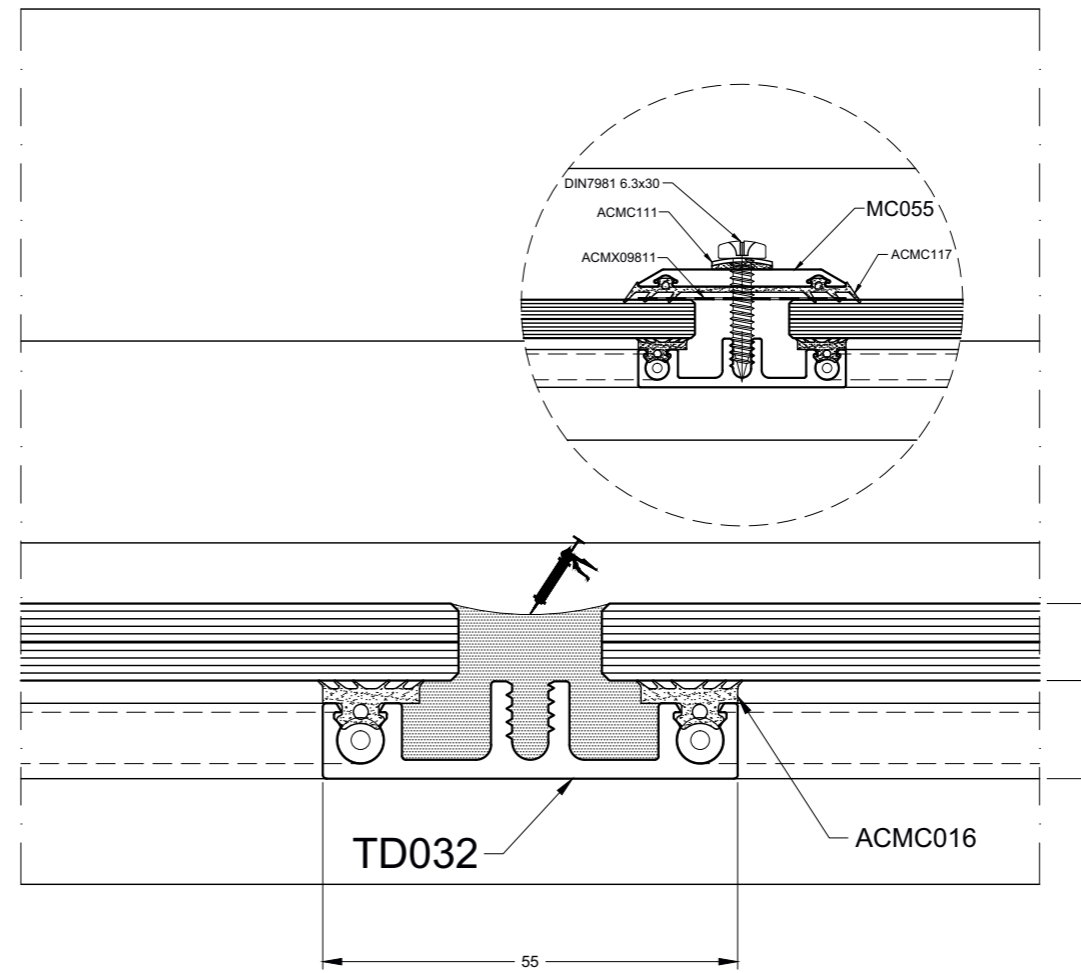
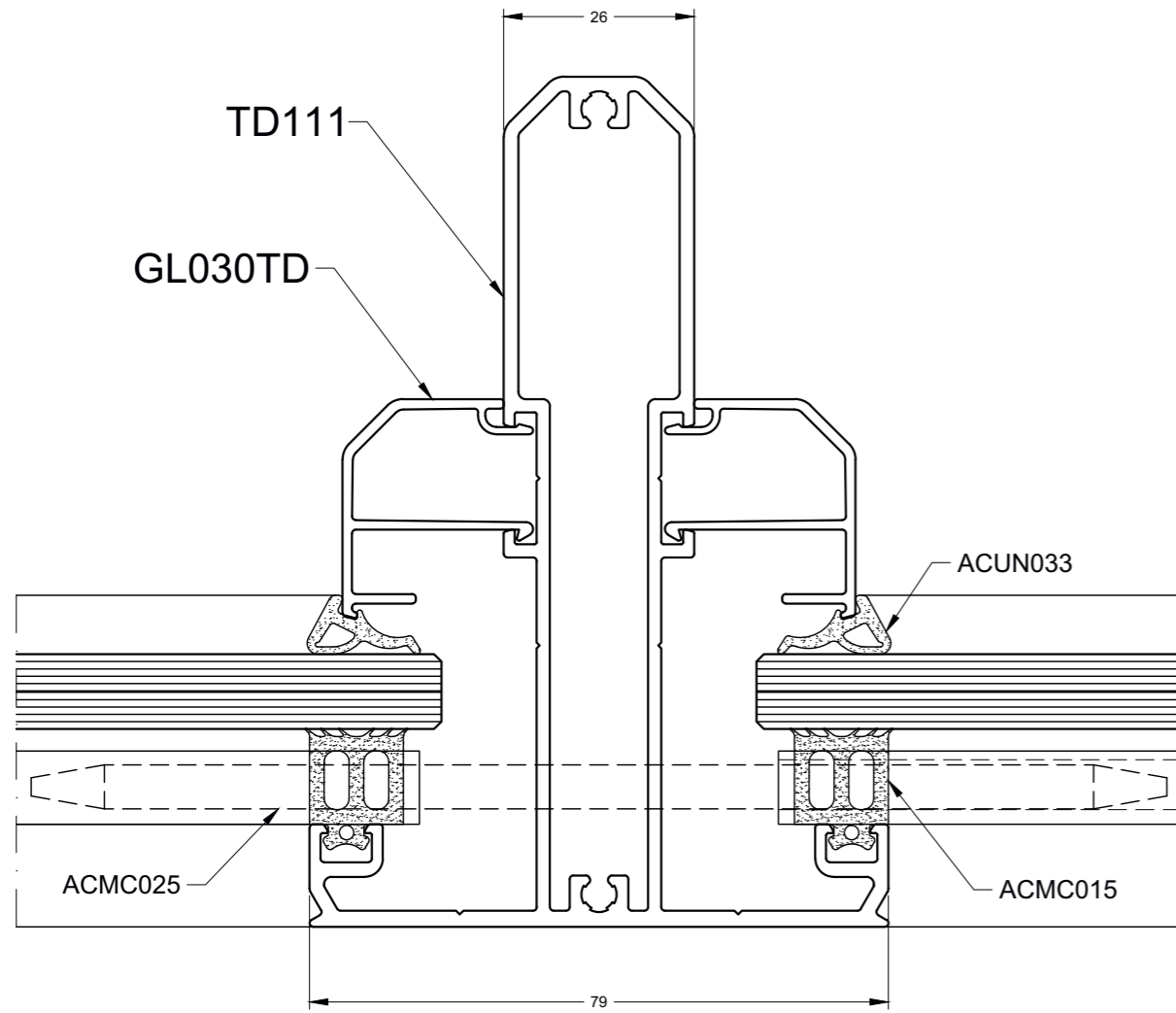

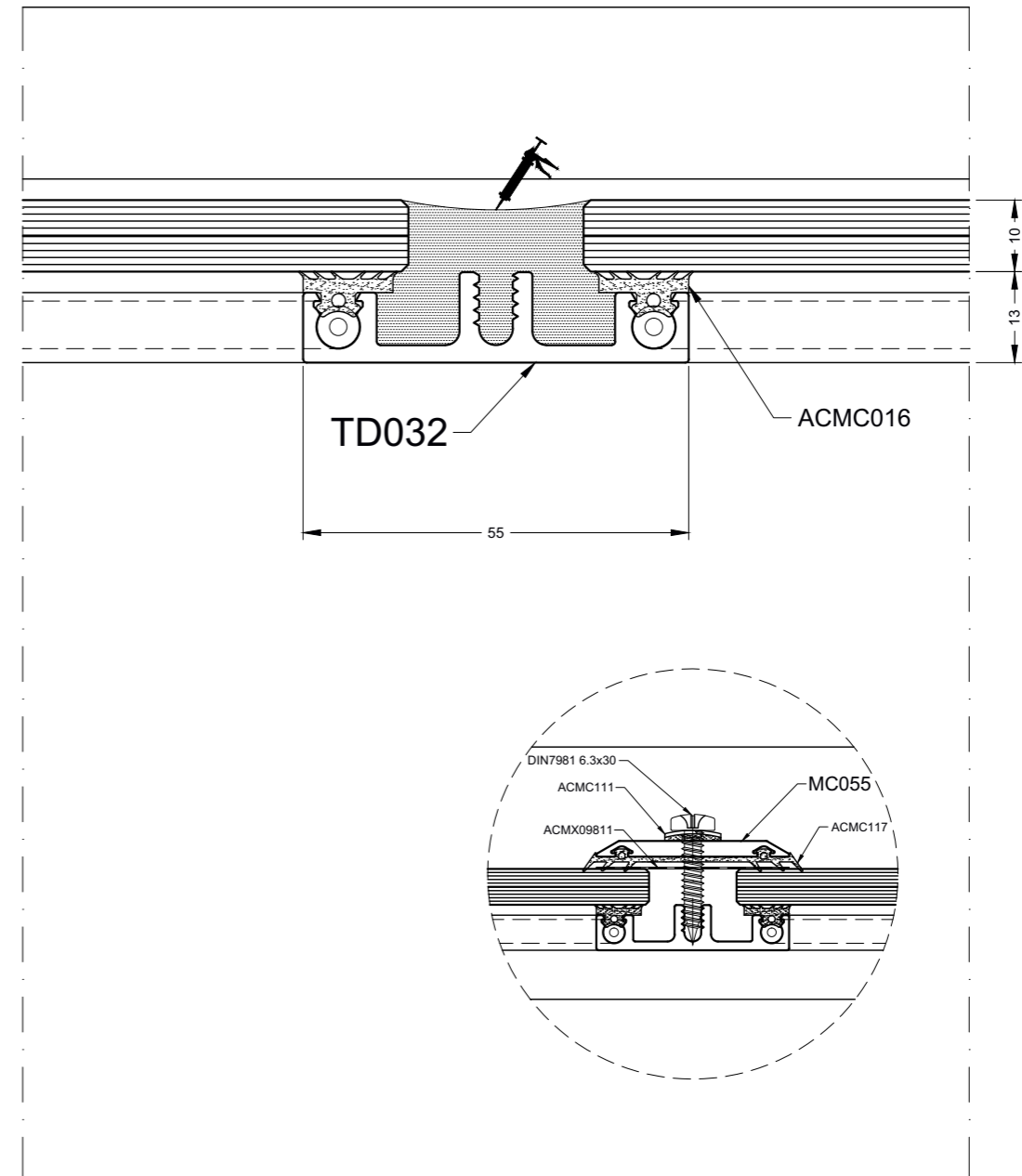
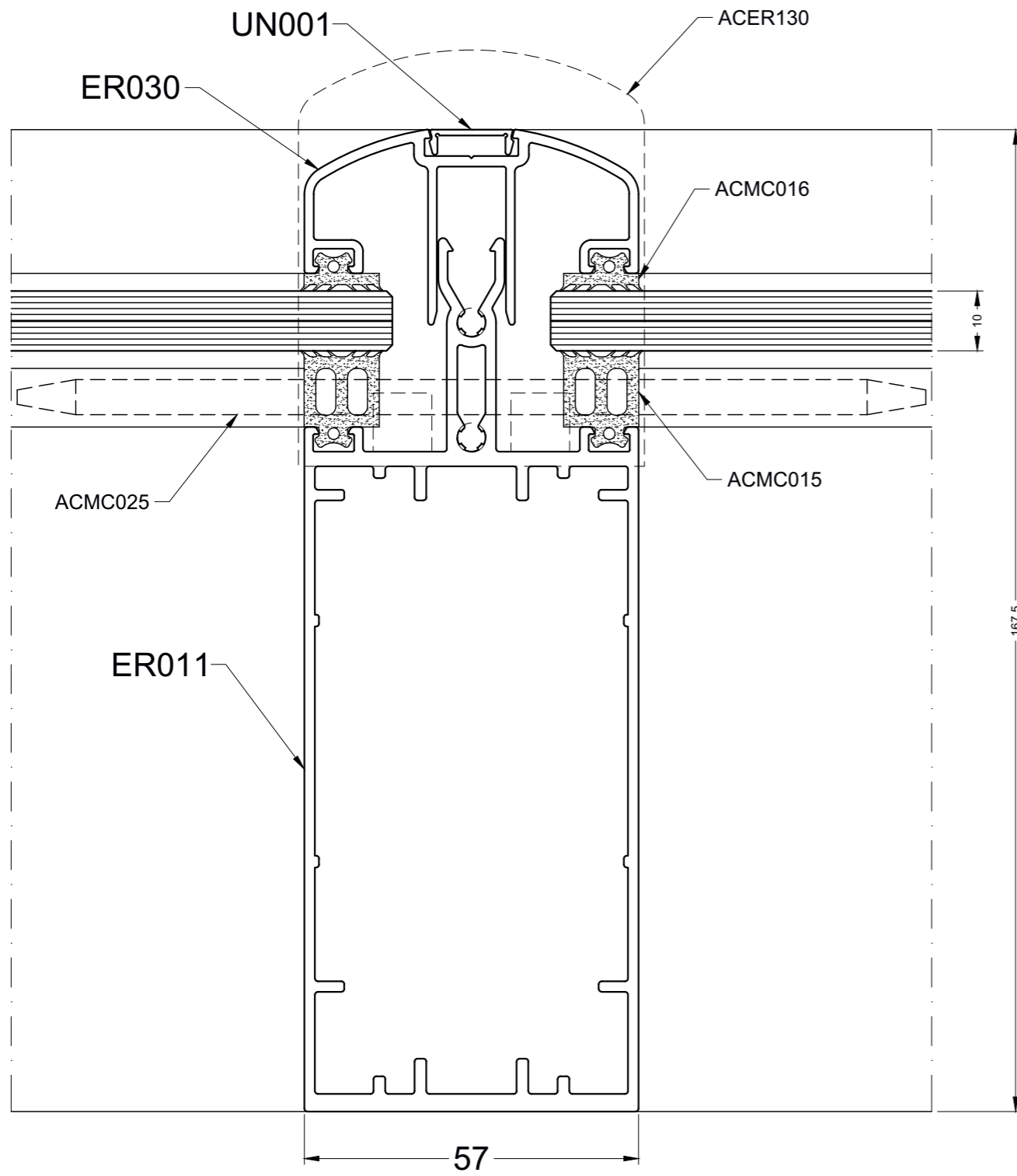

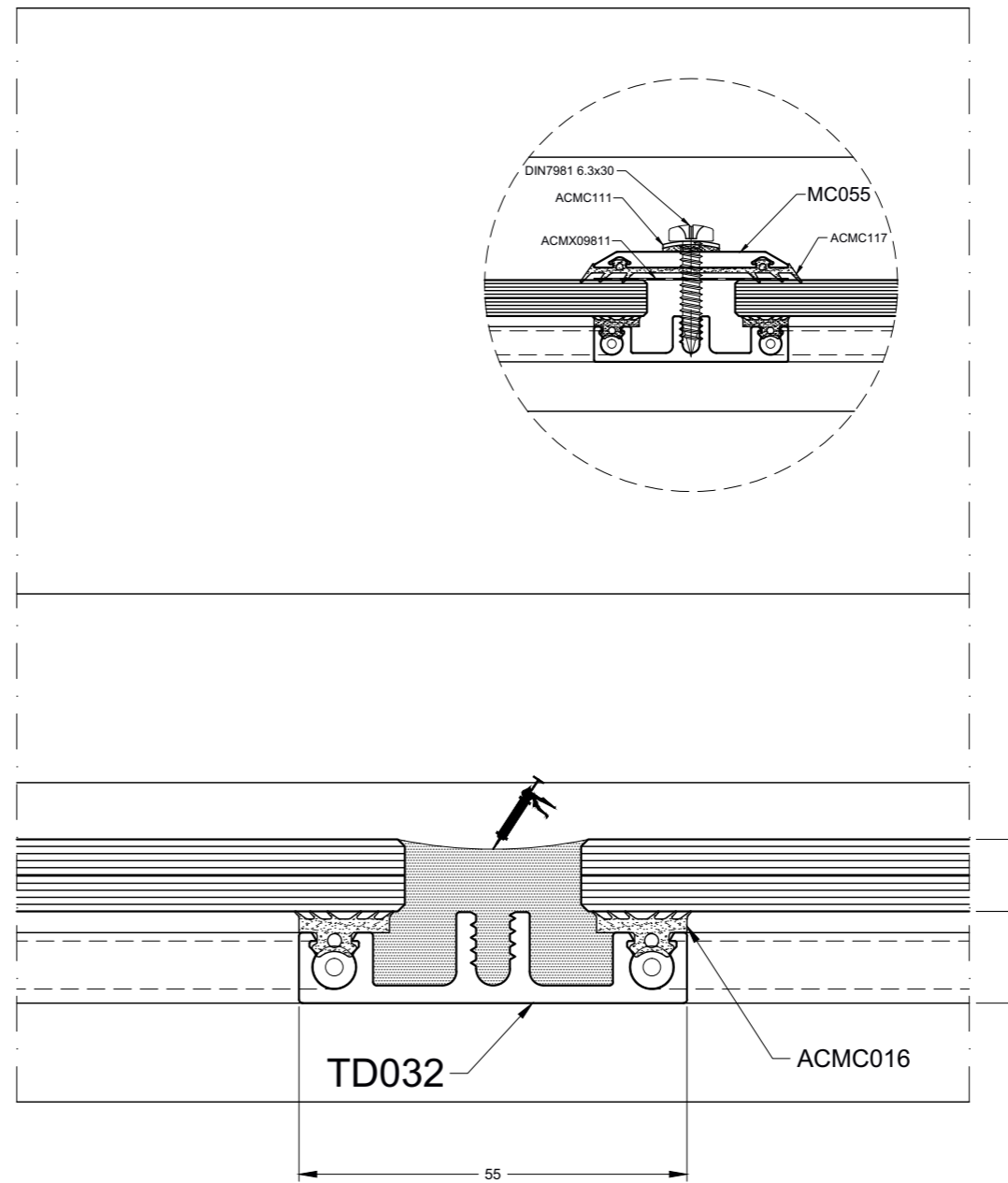
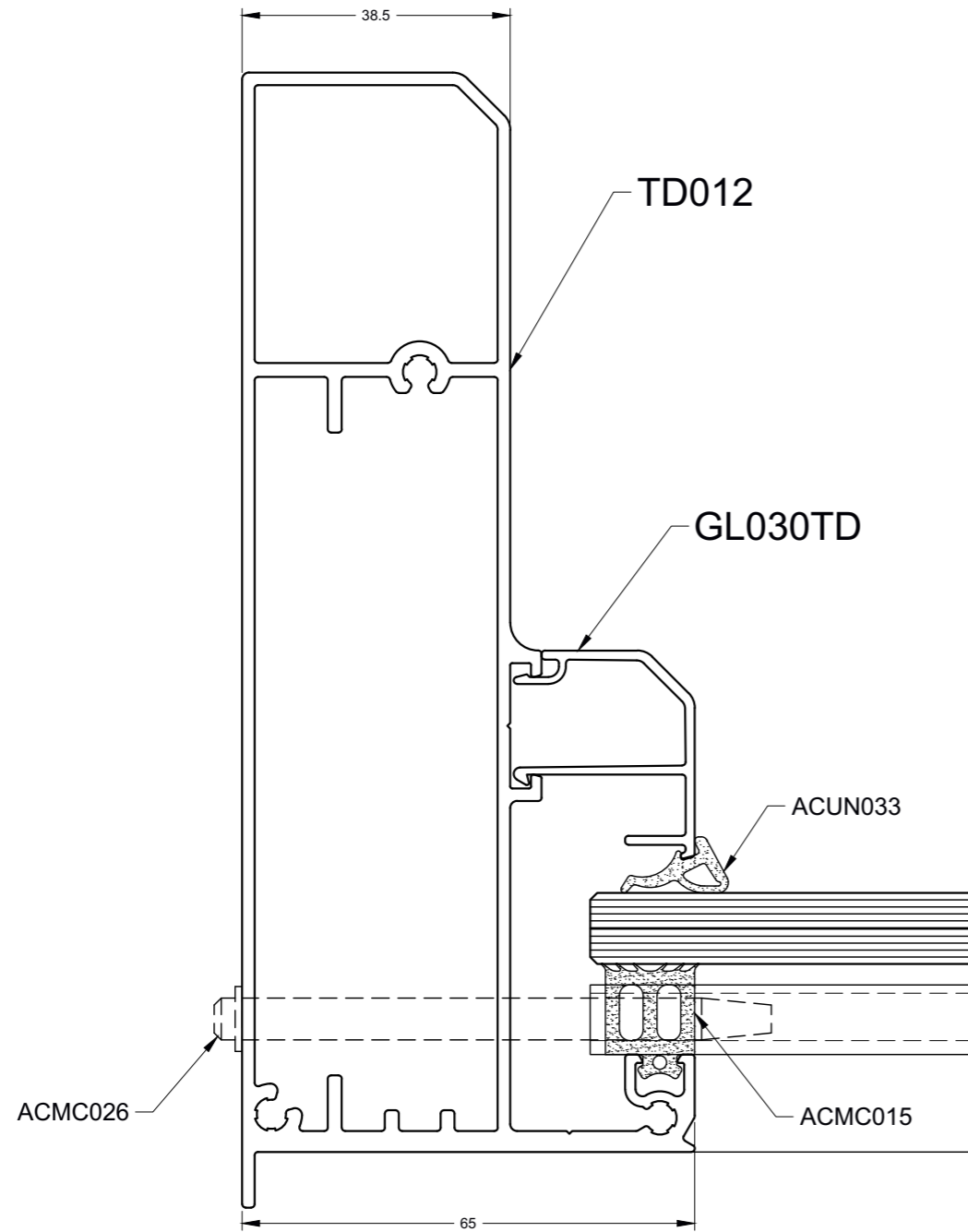



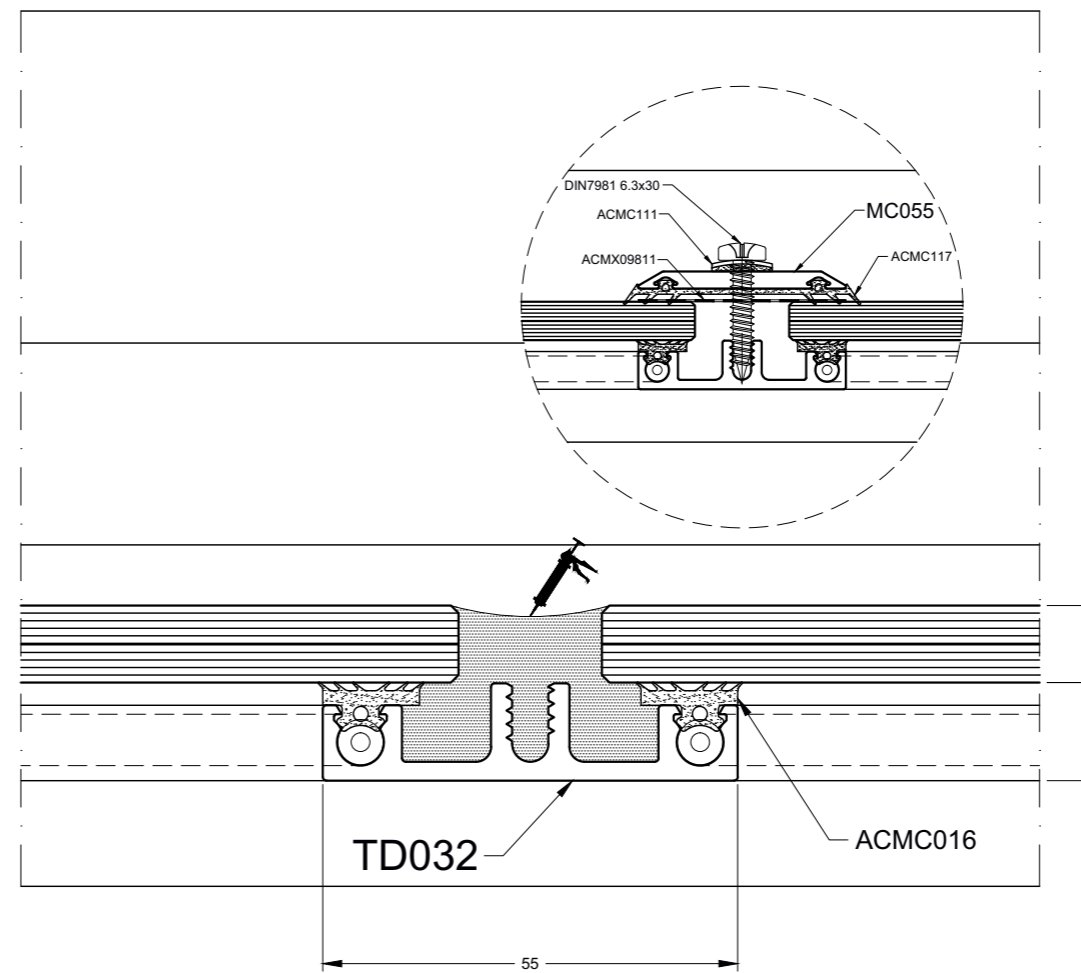
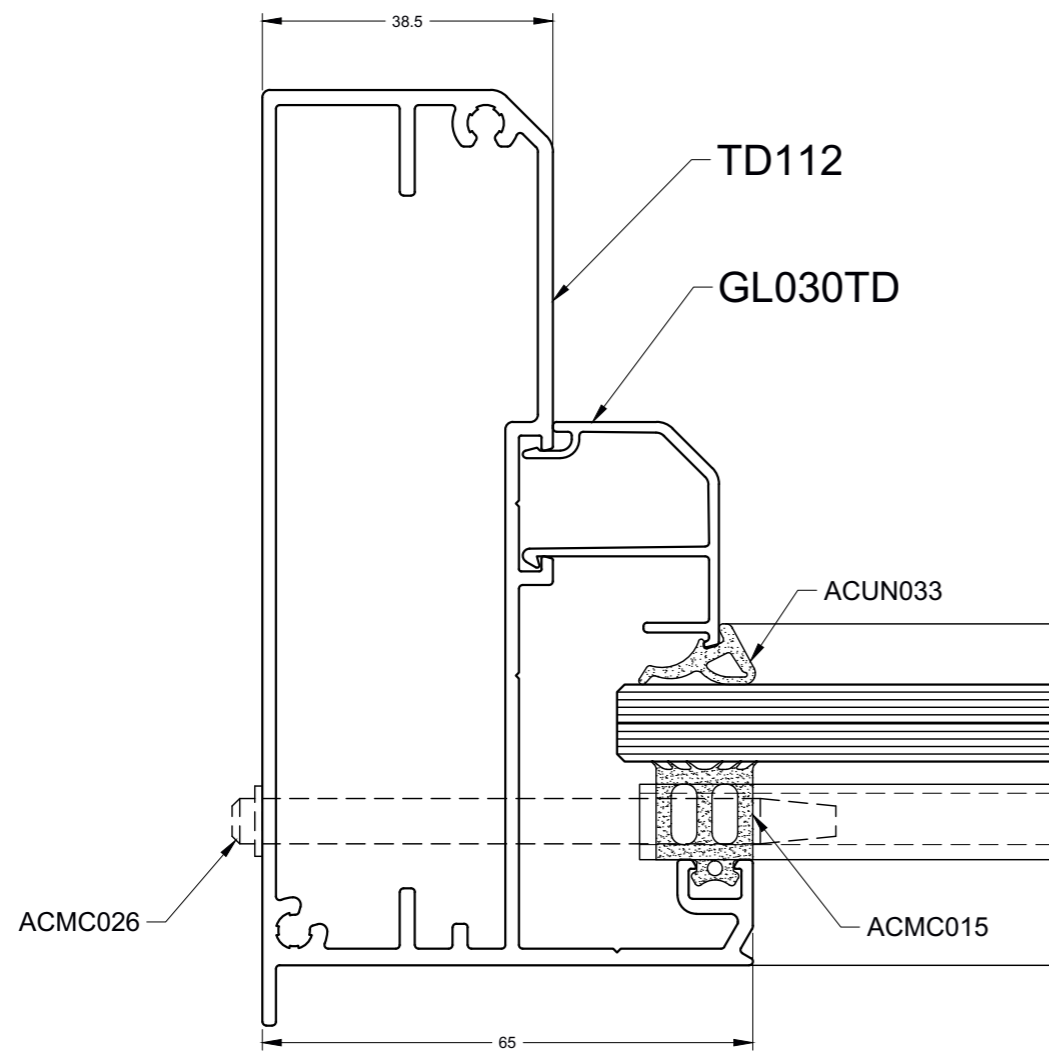

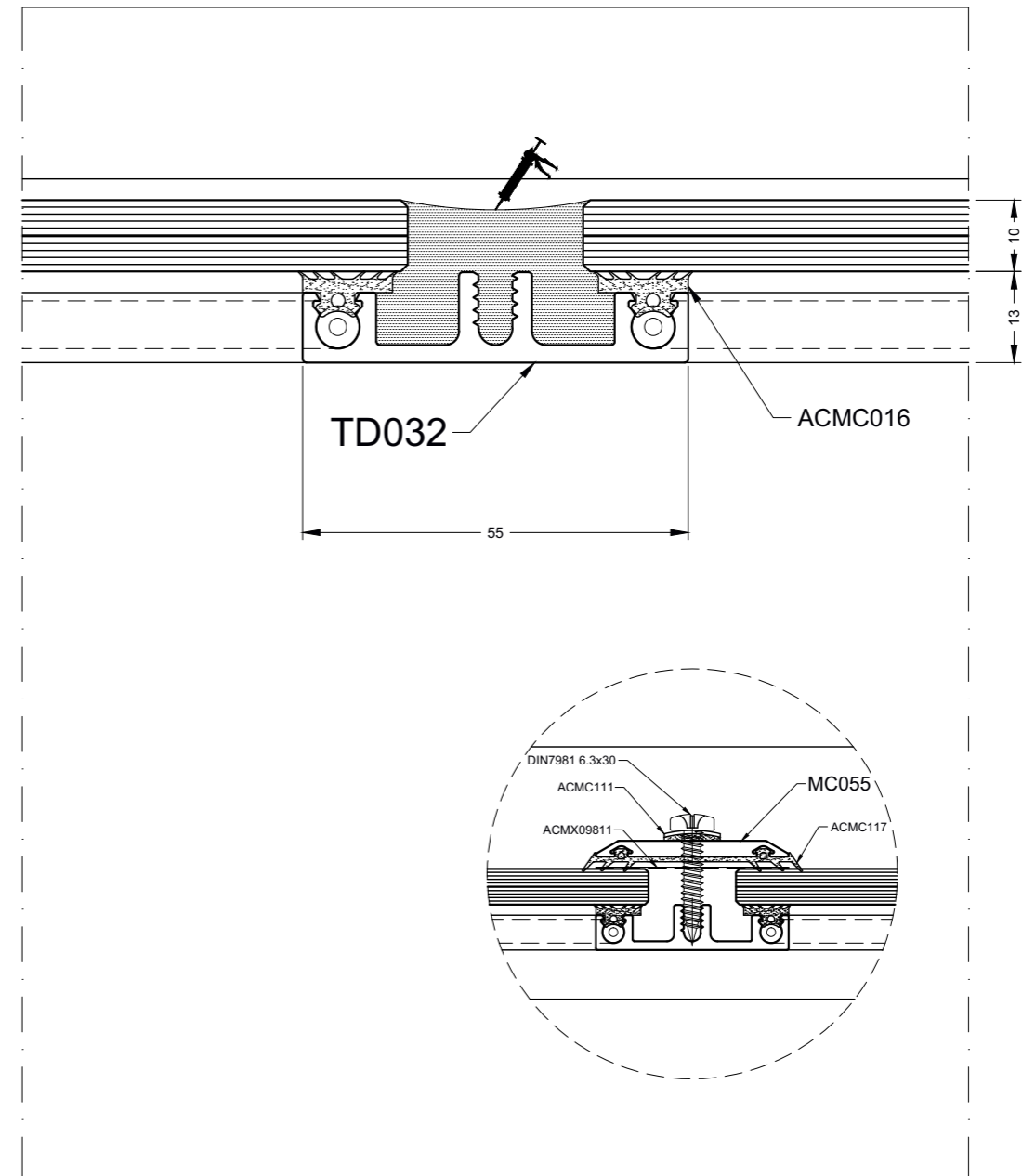
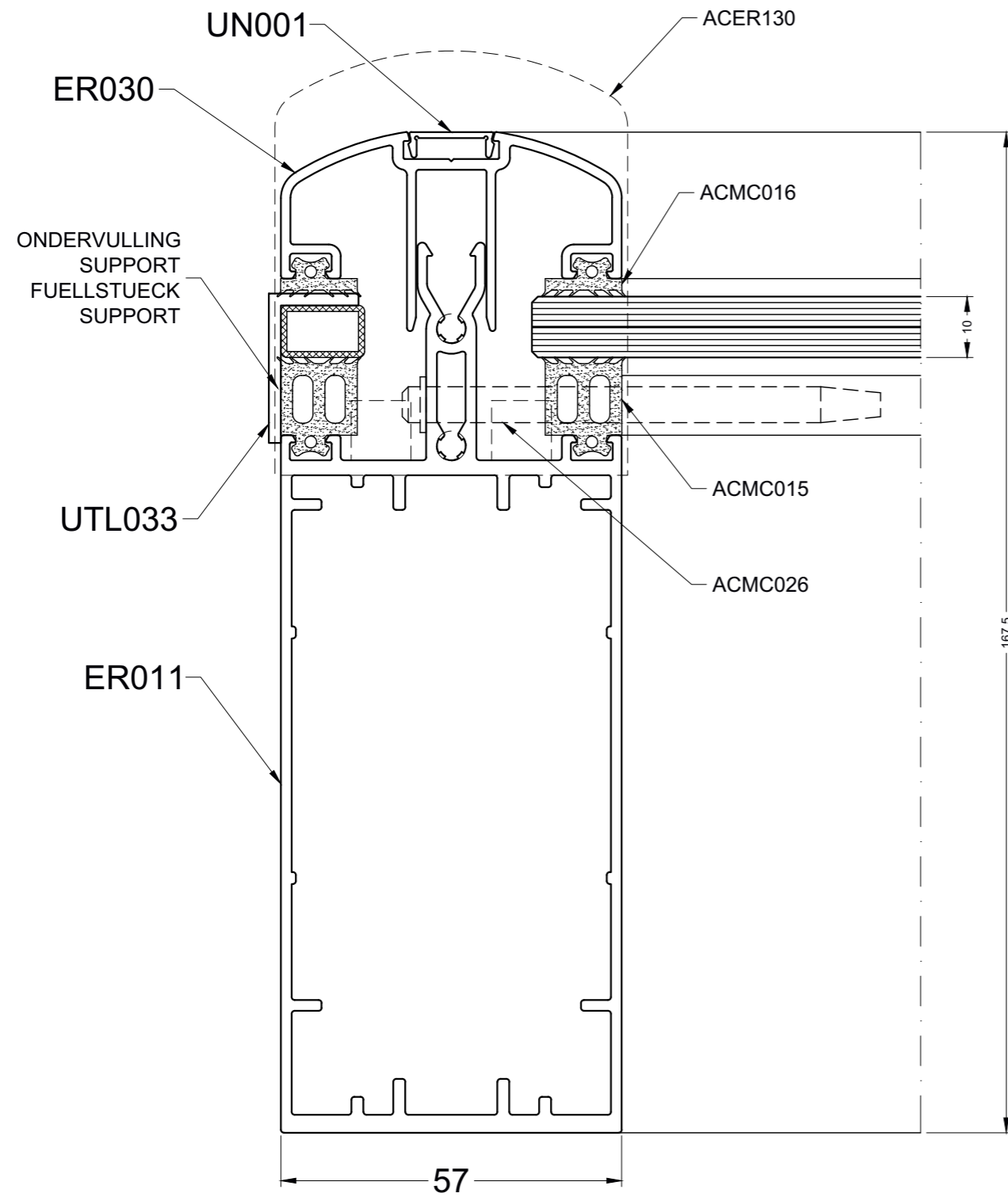

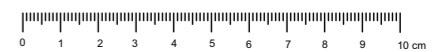
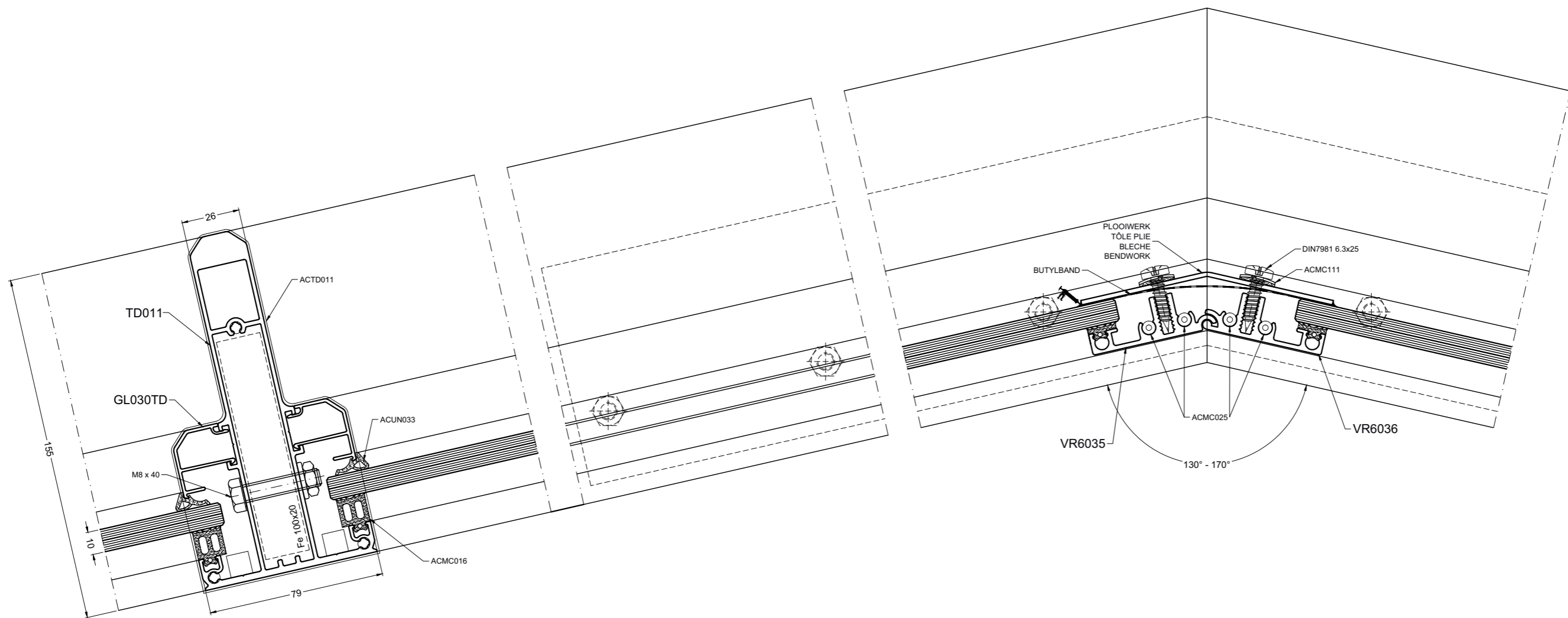

DOORSNEDETEKENINGEN - SECTIONS DE NOEUDS - PROFILKOMBINATIONEN - SECTION DRAWINGS

TD011\_004

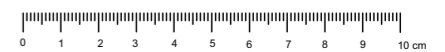

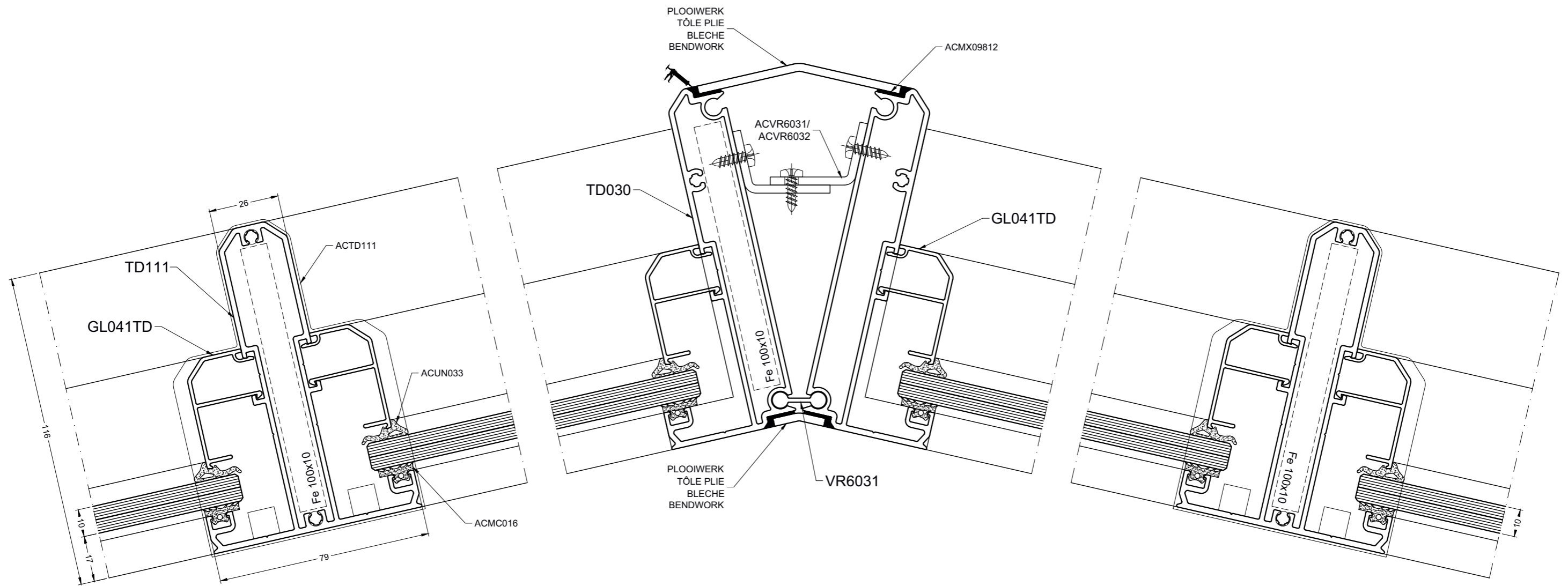

DOORSNEDETEKENINGEN - SECTIONS DE NOEUDS - PROFILKOMBINATIONEN - SECTION DRAWINGS



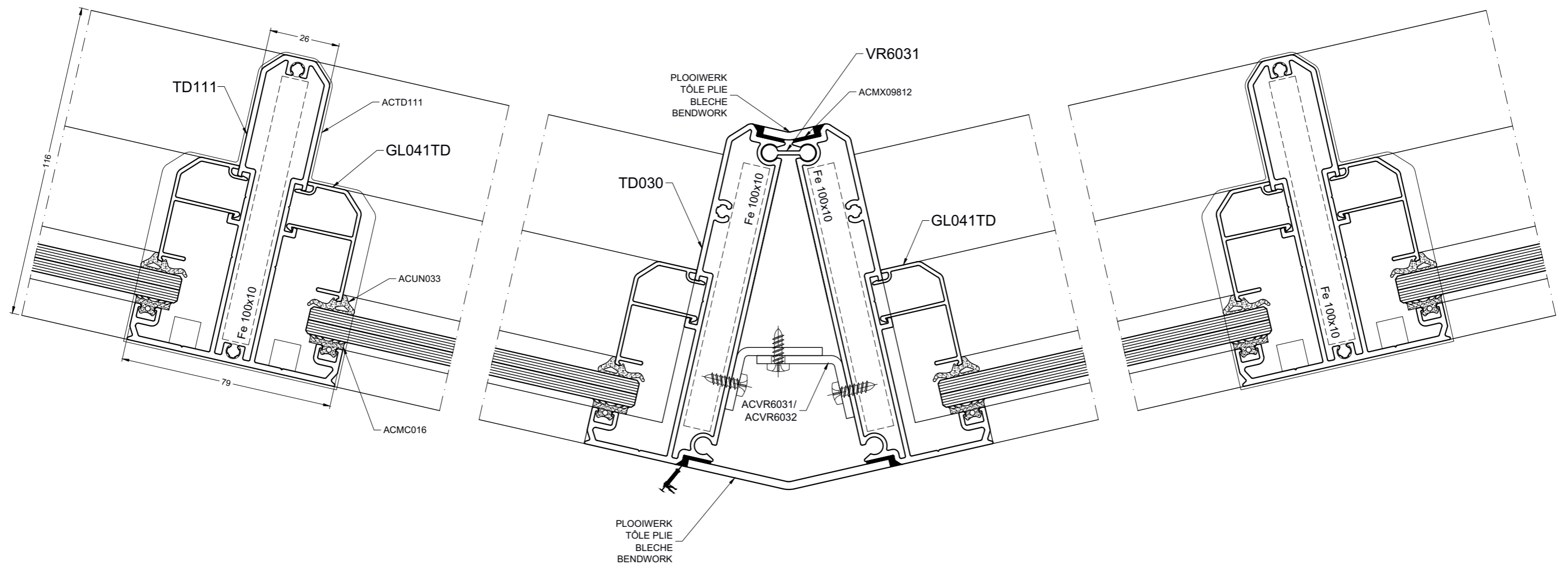

TD030\_002



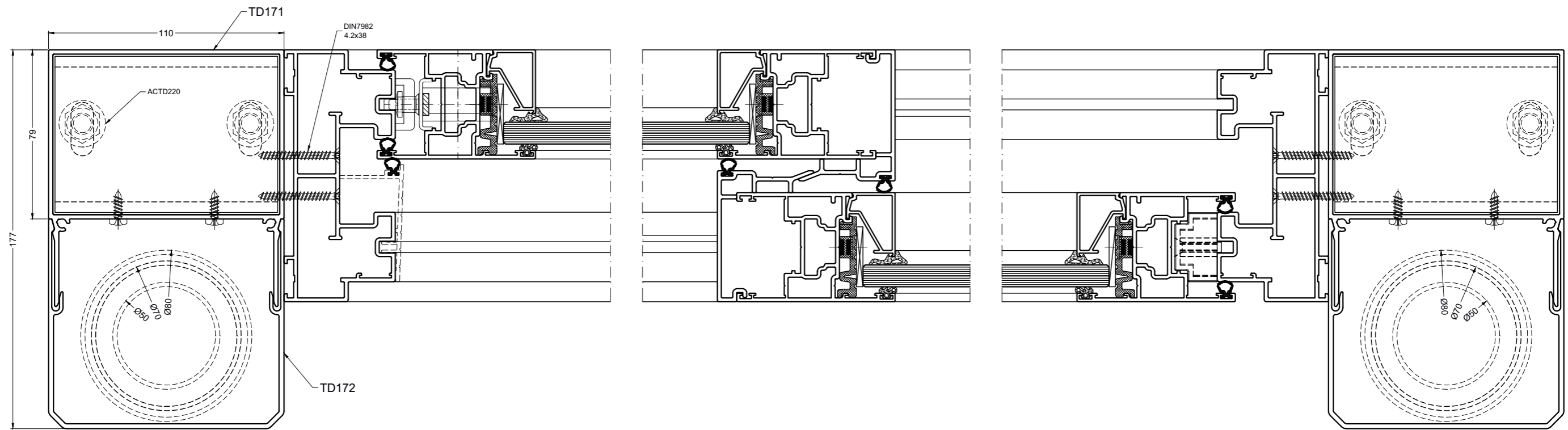





**TD020 - TD011**

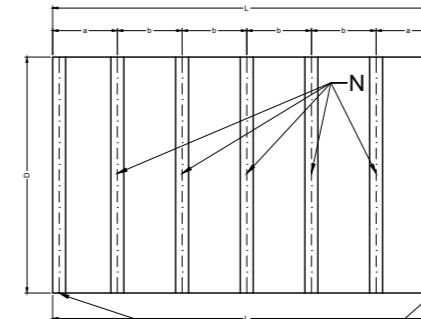
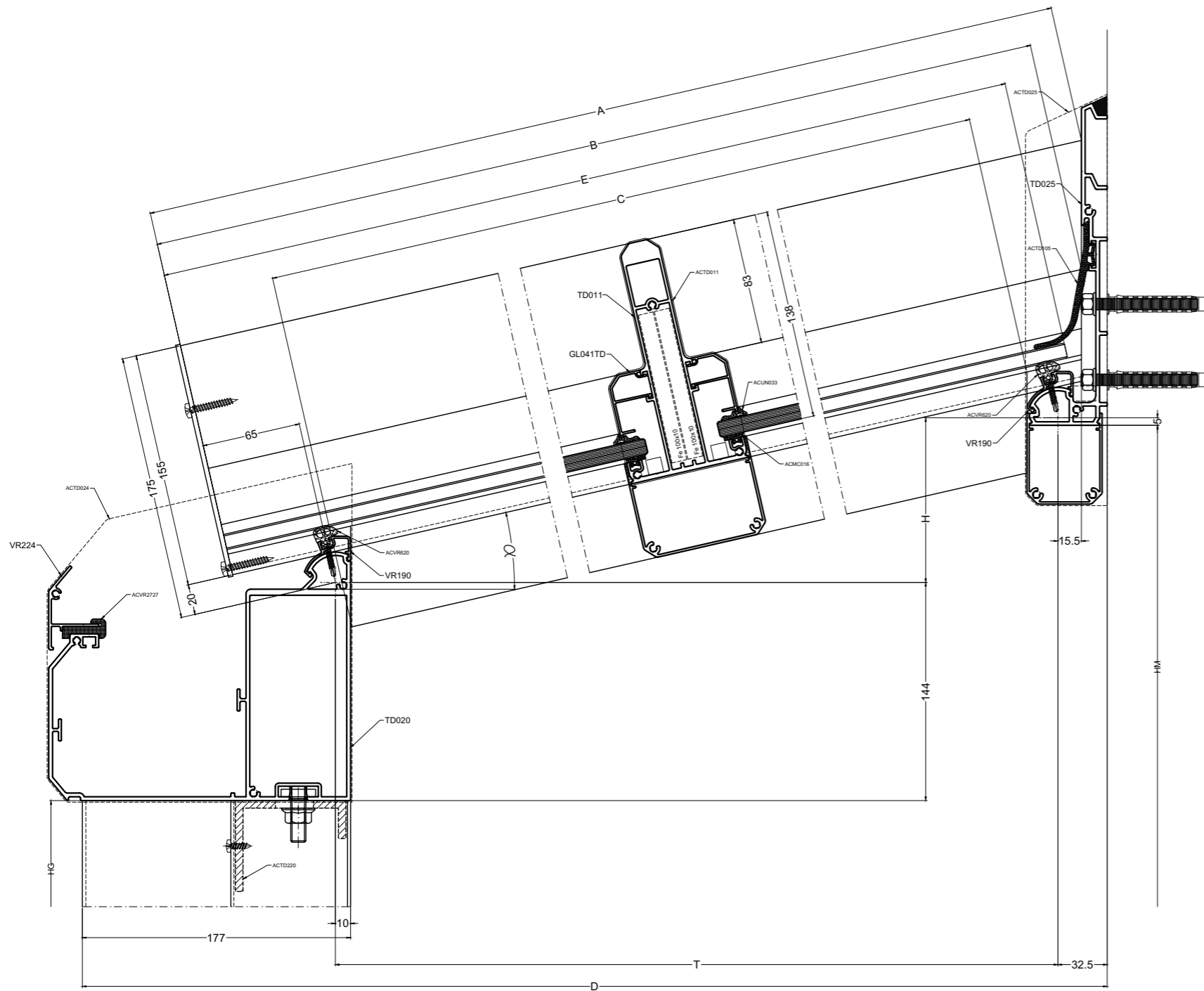

N = Anzahl Dachelemente  
Nombre de éléments  
Acidit beams  
Number of beams  
M = Anzahl Stahlgitter  
Montants de bois  
Acidit subbeams  
Number of subbeams

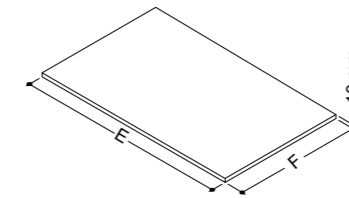

L	
D	
H	HM - (HG + 144) + 5
T	D - (167+32.5)
N	
M	
$\alpha$	ARCTAN (H/T)
A	$(T / (\cos \alpha)) + (175 * (\tan \alpha)) + (15.5 / (\cos \alpha)) + 65$
B	$A - (83 * (\tan \alpha))$
C	$(31 * (\tan \alpha)) + ((T - 30.4) / (\cos \alpha)) + ((34 * (\tan \alpha))$
E	$A - (138 * (\tan \alpha)) - 5$
F	$L - (100 + (N * 49)) / (N + 1)$

PROFILEN / PROFILES / PROFILS / PROFILS				
TD020		1		L
VR190		2 x (N+1)		$L - (100 + (N * 79)) / (N + 1)$
TD025		1		L
TD011		N		A
TD012		M		A
GL041TD		(2xN) + M		B
TD171		2		HG
TD172		2		HG

(*) OPTIONEEL / OPTIONNEL / FAKULTATIV / OPTIONAL				
TD211		N		C
TD225		1		L
TD001		1		L - 220
VR224		1		L
ACVR2727				L/300

TOEBEHOREN / ACCESSOIRES / ZUBEHÖRTEILE / ACCESSORIES				
ACVR620		2 x (N+1)		(F - 30)
ACMC016		(2xN) + M		E
ACUN033		(2xN) + M		E
(*) ACTD100		(2xN) + M		E
ACTD105		1		L
ACTD011		N		
ACTD012		M		
ACTD020		2		
(*) ACTD024		2		
ACTD025		2		
ACTD220		2		
(*) ACTD026		2		

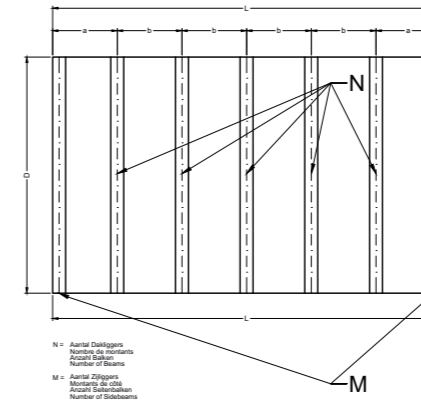
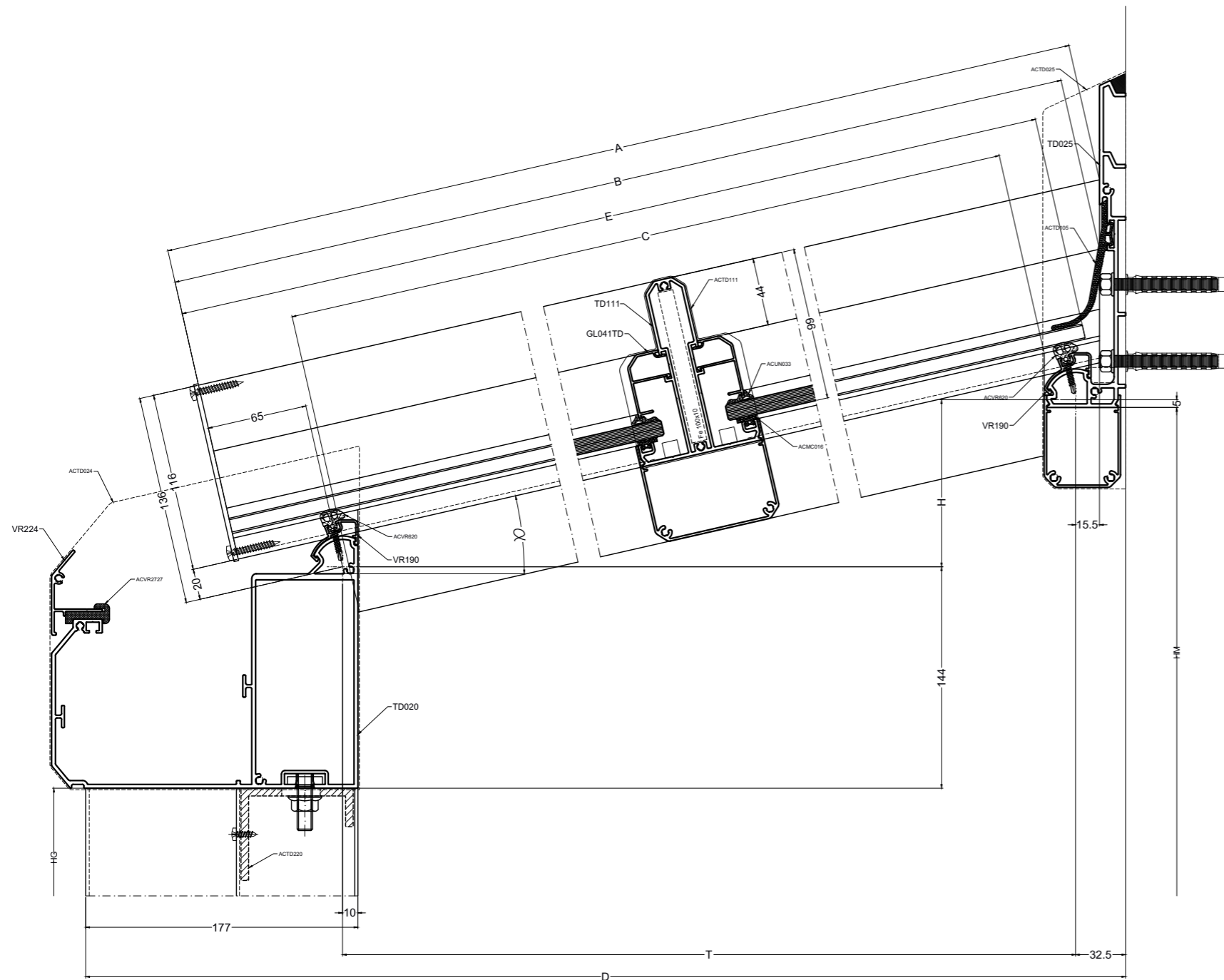

N = Anzahl Stelgen  
Nombre de poutres  
Acidit Stelgen  
Number of Beams

M = Anzahl Stelgen  
Montants de ciel  
Acidit Stelgen  
Number of Slats

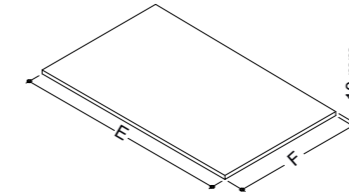

L	
D	
H	HM - (HG + 144) + 5
T	D - (167+32.5)
N	
M	
$\alpha$	ARCTAN (H/T)
A	$(T / (\cos \alpha)) + (136 * (\tan \alpha)) + (15.5 / (\cos \alpha)) + 65$
B	$A - (44 * (\tan \alpha))$
C	$(31 * (\tan \alpha)) + ((T - 30.4) / (\cos \alpha)) + ((34 * (\tan \alpha))$
E	$A - (99 * (\tan \alpha)) - 5$
F	$L - (100 + (N * 43)) / (N + 1)$

### PROFIELEN / PROFILES / PROFILES / PROFILS

TD020		1		L
VR190		2 x (N+1)		$L - (100 + (N * 79)) / (N + 1)$
TD025		1		L
TD111		N		A
TD112		M		A
GL041TD		(2xN) + M		B
TD171		2		HG
TD172		2		HG

### (\*) OPTIONEEL / OPTIONNEL / FAKULTATIV / OPTIONAL

TD211		N		C
TD225		1		L
TD001	-	1		L - 220
VR224		1		L
ACVR2727	-			L/300

### TOEBEHOREN / ACCESSOIRES / ZUBEHÖRTEILE / ACCESSORIES

ACVR620	2 x (N+1)	(F - 36)
ACMC016	(2xN) + M	E
ACUN033	(2xN) + M	E
(*) ACTD100	(2xN) + M	E
ACTD105	1	L
ACTD111	N	
ACTD112	M	
ACTD020	2	
(*) ACTD024	2	
ACTD025	2	
ACTD220	2	
(*) ACTD026	2	

**TD020 - TD217 - ER011**

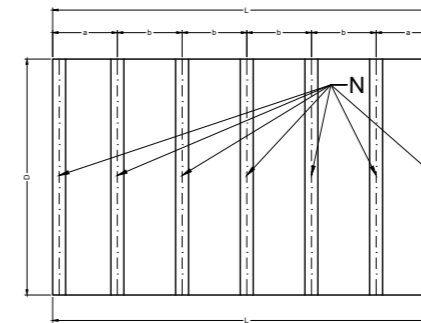
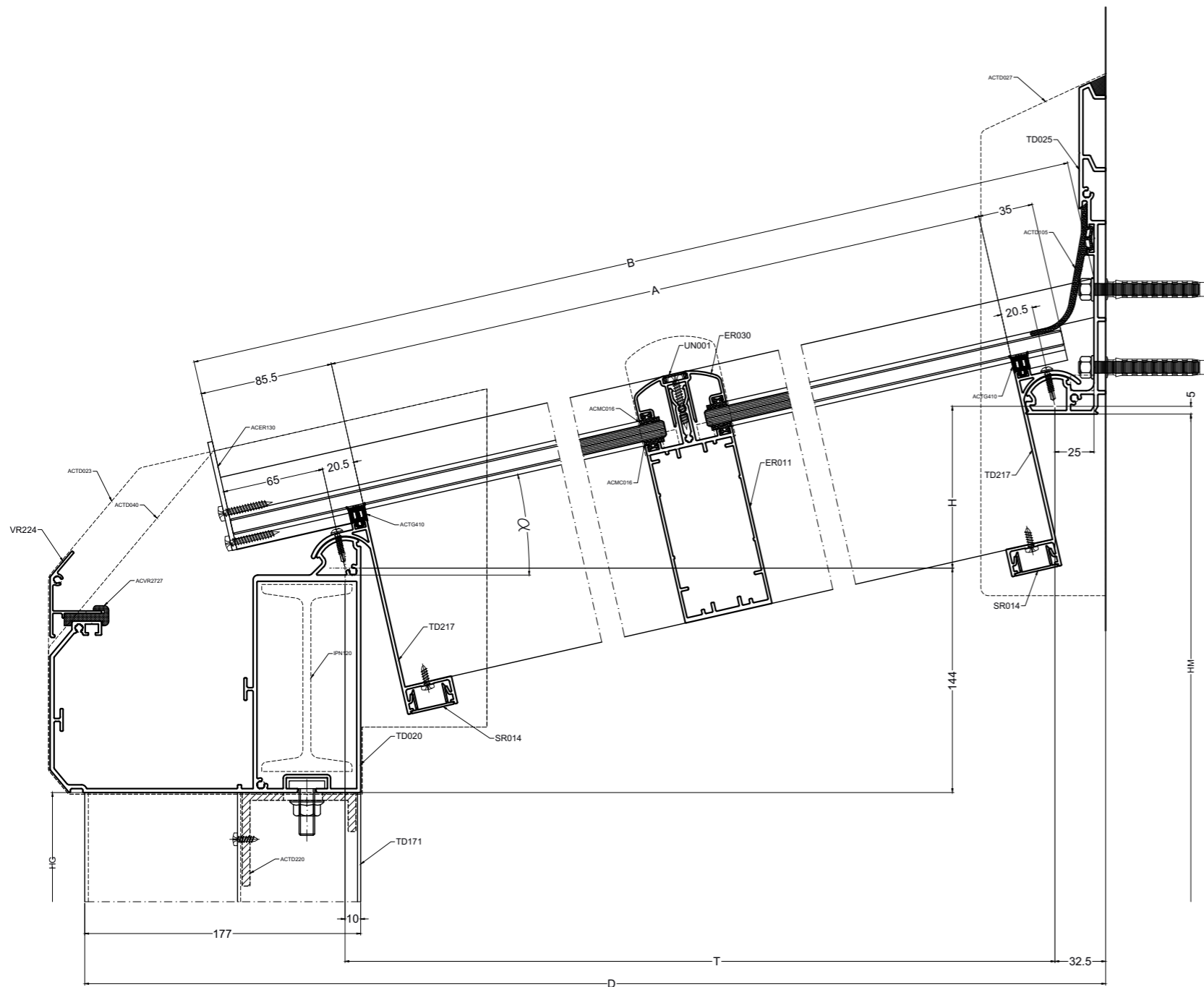

N = Anzahl Decklagen  
Nombre de Ribrants  
Acidit Ribben  
Number of Brims

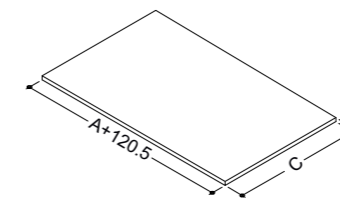

L	
D	
H	HM - (HG + 144) + 5
T	D - (167+32.5)
N	
α	ARCTAN (H/T)
A	$\sqrt{T^2 + H^2} - 41$
B	$A + 106 + (25 / (\cos \alpha)) + (74.5 * \tan \alpha)$
C	$L - (30 + (N * 27)) / (N - 1)$

PROFIELEN / PROFILES / PROFILES / PROFILS				
TD020		1		L
TD217		2		L
SR014		2		L
TD025		1		L
ER011		N		A+120.5
ER030		N		B
UN001	-	N		B
TD171		2		HG
TD172		2		HG
UTL039		2		B

(*) OPTIONEEL / OPTIONNEL / FAKULTATIV / OPTIONAL				
VR224		1		L
ACVR2727	-			L/300

TOEBEHOREN / ACCESSOIRES / ZUBEHÖRTEILE / ACCESSORIES		
ACTG410	2 x (N-1)	(C - 30)
ACMC016	(4xN)	B
ACTD105	1	L
ACER130	N	
ACTD023	2	
(*) ACTD040	2	
ACTD027	2	
ACTD220	2	

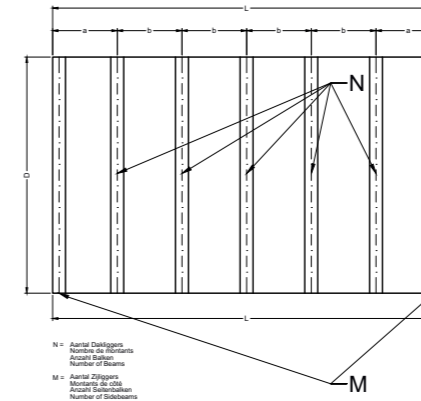
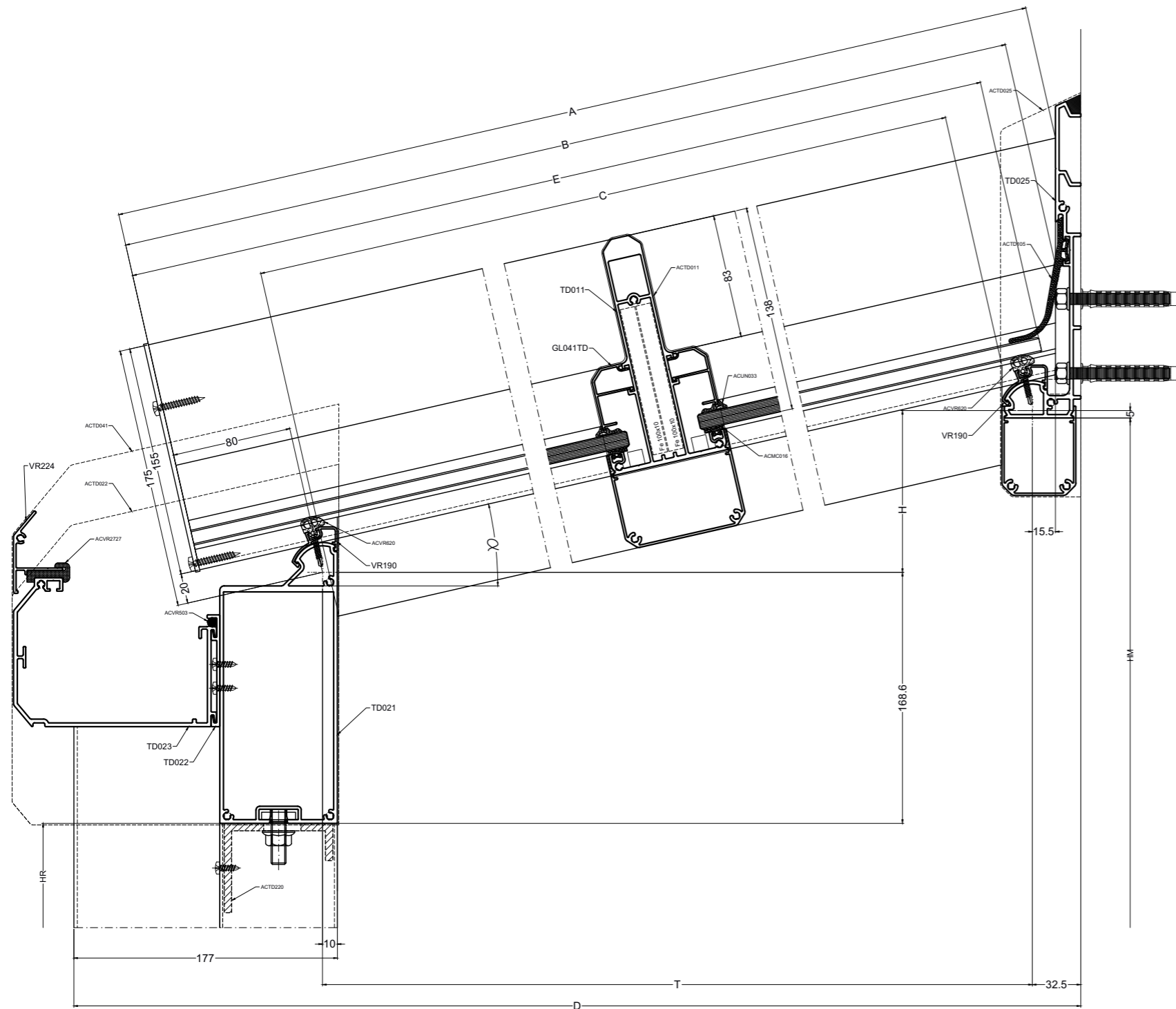

N = Anzahl Stützpunkte  
Number of Brackets  
Nombres de Supports  
Número de Soportes

M = Anzahl Stützpunkte  
Number of Brackets  
Nombres de Supports  
Número de Soportes

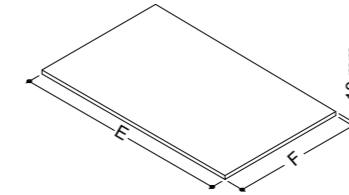

L	
D	
H	$HM - (HR + 168.6) + 5$
T	$D - (167 + 32.5)$
N	
M	
$\alpha$	ARCTAN (H/T)
A	$(T / (\cos \alpha)) + (175 * (\tan \alpha)) + (15.5 / (\cos \alpha)) + 80$
B	$A - (83 * (\tan \alpha))$
C	$(31 * (\tan \alpha)) + ((T - 30.4) / (\cos \alpha)) + ((34 * (\tan \alpha))$
E	$A - (138 * (\tan \alpha)) - 5$
F	$L - (100 + (N * 49)) / (N + 1)$

### PROFIELEN / PROFILES / PROFILES / PROFILS

TD021		1		L
TD022		1		L
TD023		1		L
VR190		$2 \times (N+1)$		$L - (100 + (N * 79)) / (N + 1)$
TD025		1		L
TD011		N		A
TD012		M		A
GL041TD		$(2xN) + M$		B
TD171		2		HG
TD172		2		HG

### (\*) OPTIONEEL / OPTIONNEL / FAKULTATIV / OPTIONAL

TD211		N		C
TD225		1		L
TD001		1		L - 220
VR224		1		L
ACVR2727				L/300

### TOEBEHOREN / ACCESSOIRES / ZUBEHÖRTEILE / ACCESSORIES

ACVR620	$2 \times (N+1)$	(F - 30)
ACVR503	1	L
ACMC016	$(2xN) + M$	E
ACUN033	$(2xN) + M$	E
(*) ACTD100	$(2xN) + M$	E
ACTD105	1	L
ACTD011	N	
ACTD012	M	
ACTD022	2	
(*) ACTD041	2	
ACTD025	2	
ACTD220	2	
(*) ACTD026	2	

**TD021 - TD111**

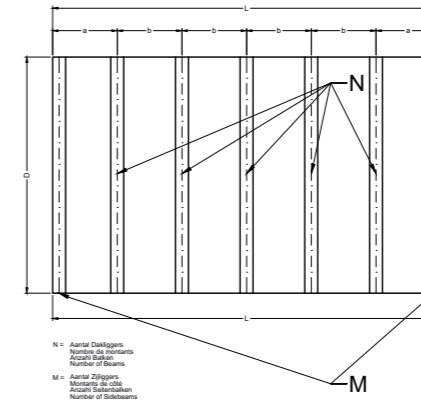
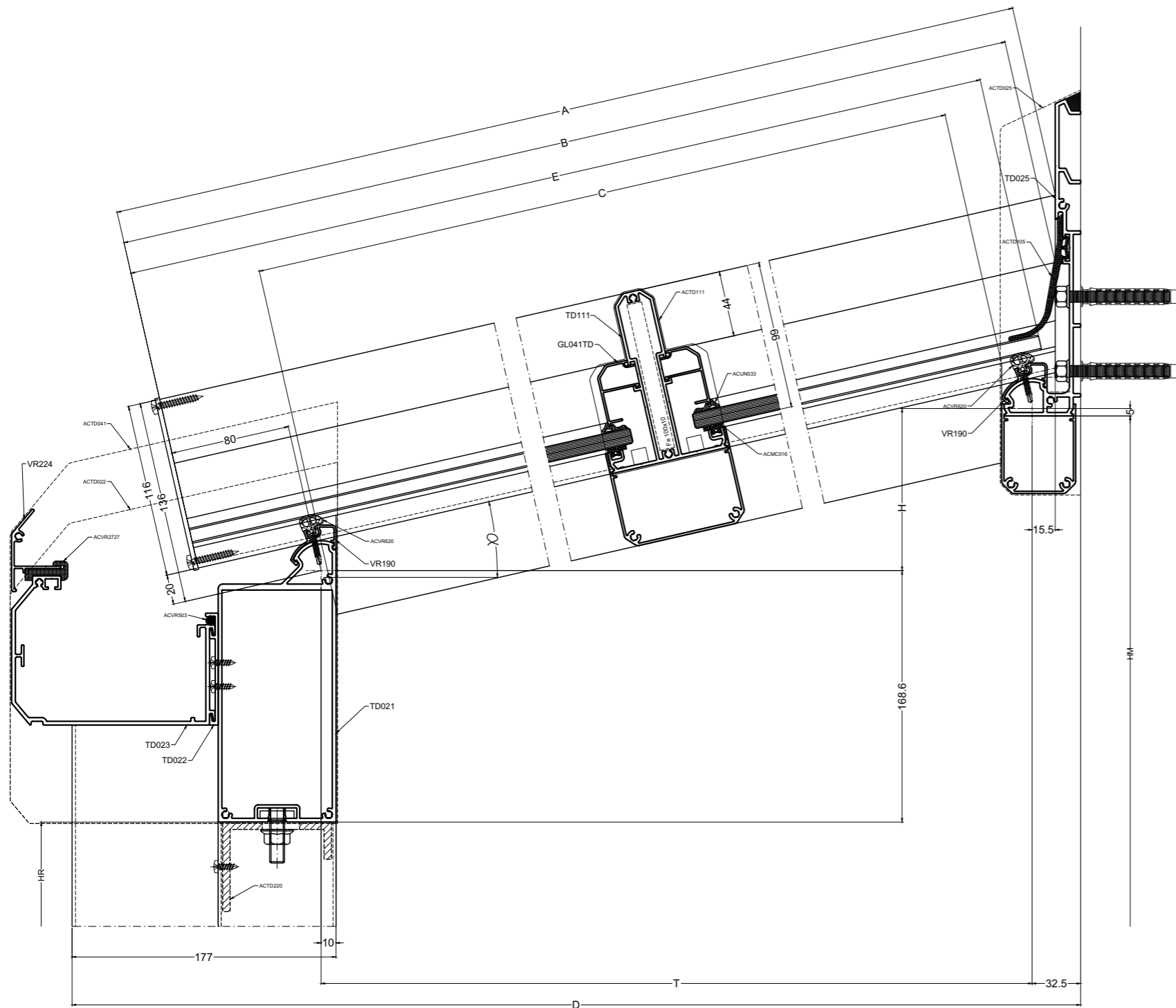

N = Anzahl Decklagen  
Number of floors  
Niveau de planches  
Number of beams  
M = Anzahl Stützen  
Mounts de bois  
Ancres d'acier  
Number of brackets

L	
D	
H	$HM - (HR + 168.6) + 5$
T	$D - (167 + 32.5)$
N	
M	
$\alpha$	ARCTAN (H/T)
A	$(T / (\cos \alpha)) + (136 * (\tan \alpha)) + (15.5 / (\cos \alpha)) + 80$
B	$A - (44 * (\tan \alpha))$
C	$(31 * (\tan \alpha)) + ((T - 30.4) / (\cos \alpha)) + ((34 * (\tan \alpha))$
E	$A - (99 * (\tan \alpha)) - 5$
F	$L - (100 + (N * 43)) / (N + 1)$

PROFILEN / PROFILES / PROFILS / PROFILS

TD021		1		L
TD022		1		L
TD023		1		L
VR190		2 x (N+1)		$L - (100 + (N * 79)) / (N + 1)$
TD025		1		L
TD111		N		A
TD112		M		A
GL041TD		(2xN) + M		B
TD171		2		HG
TD172		2		HG

(\*) OPTIONEEL / OPTIONNEL / FAKULTATIV / OPTIONAL

TD211		N		C
TD225		1		L
TD001		1		L - 220
VR224		1		L
ACVR2727				L/300

TOEBEHOREN / ACCESSOIRES / ZUBEHÖRTEILE / ACCESSORIES

ACVR620	2 x (N+1)	(F - 36)
ACMC016	(2xN) + M	E
ACUN033	(2xN) + M	E
ACVR503	1	L
(*) ACTD100	(2xN) + M	E
ACTD105	1	L
ACTD111	N	
ACTD112	M	
ACTD022	2	
(*) ACTD041	2	
ACTD025	2	
ACTD220	2	
(*) ACTD026	N	

TD021-TD111

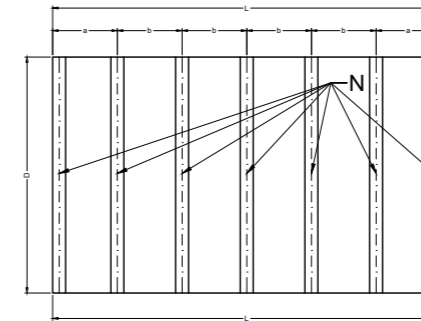
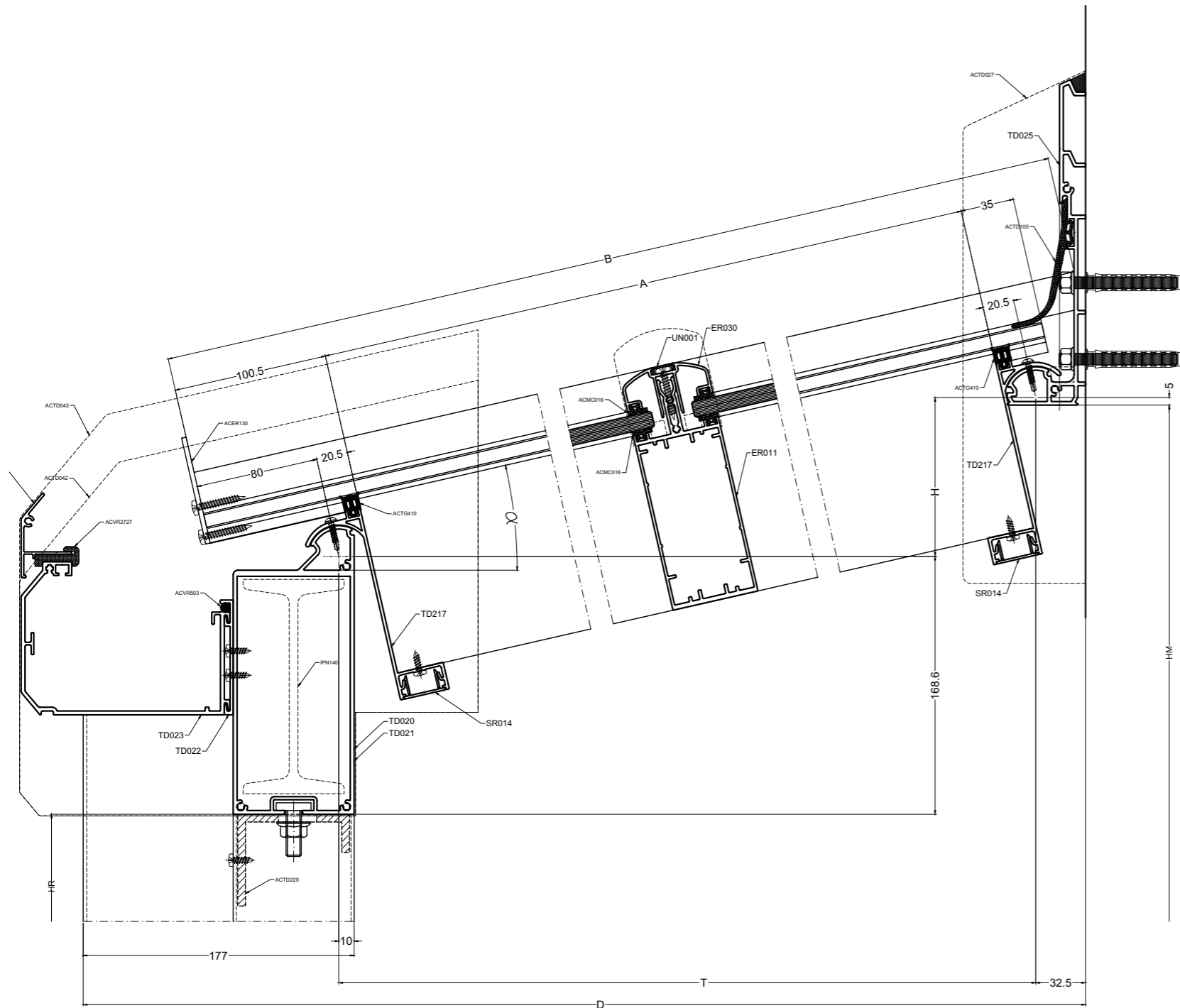

N = Anzahl Dachprofile  
 Nombre de Râblants  
 Anzahl Balken  
 Number of Beams

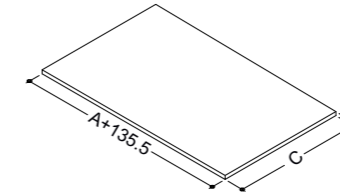

L	
D	
H	$HM - (HR + 168.6) + 5$
T	$D - (167 + 32.5)$
N	
$\alpha$	$\text{ARCTAN}(H/T)$
A	$\sqrt{T^2 + H^2} - 41$
B	$A + 121 + (25 / (\cos \alpha)) + (74.5 * \tan \alpha)$
C	$L - (30 + (N * 27)) / (N - 1)$

### PROFIELEN / PROFILES / PROFILS / PROFILS

TD021		1		L
TD022		1		L
TD023		1		L
TD217		2		L
SR014		2		L
TD025		1		L
ER011		N		A+135.5
ER030		N		B
UN001		N		B
TD171		2		HG
TD172		2		HG
UTL039		2		B

### (\*) OPTIONEEL / OPTIONNEL / FAKULTATIV / OPTIONAL

VR224		1		L
ACVR2727				L/300

### TOEBEHOREN / ACCESSOIRES / ZUBEHÖRTEILE / ACCESSORIES

ACTG410	2 x (N-1)			(C - 30)
ACMC016	(4xN)			B
ACVR503	1			L
ACTD105	1			L
ACER130	N			
ACTD023	2			
ACTD040	2			
ACTD027	2			
ACTD220	2			

**TD021 - TD011**

DAKOVERSTEEK - DÉBORD DE TOIT - DACHÜBERSTAND - ROOF OVERHANG

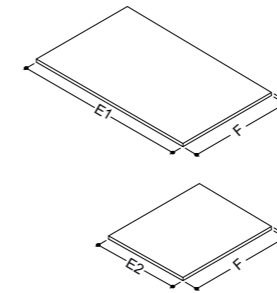
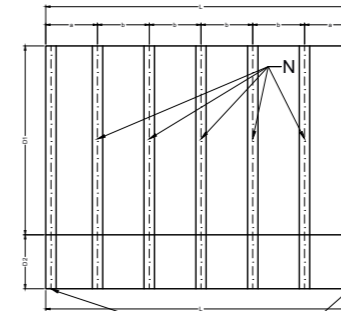
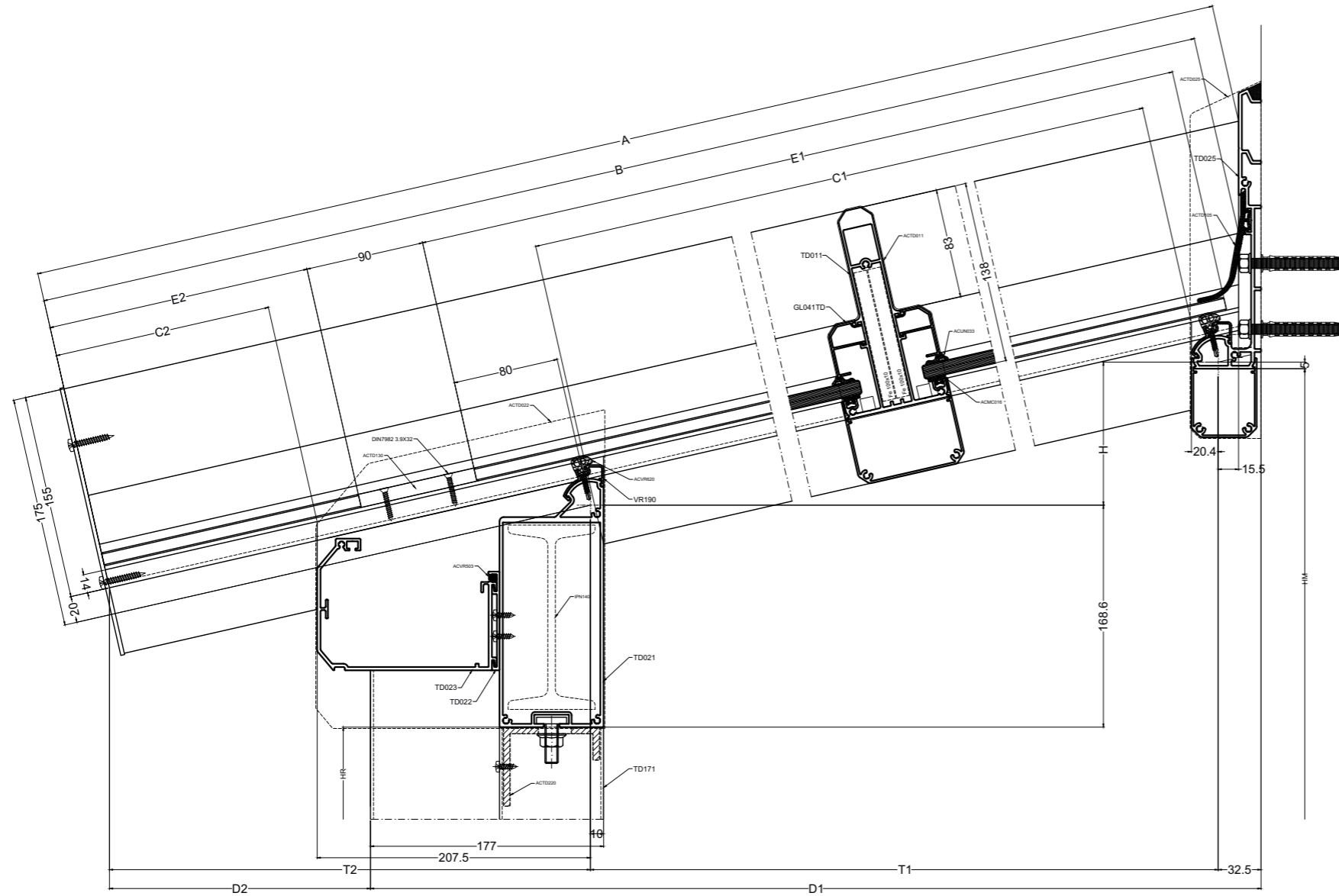

L	
D1	
D2	
H	HM - (HR + 168.6) + 5
T1	D1 - (167 * 32.5)
T2	D2 + 167
N	
M	
α	ARCTAN (H/T)
A	(T1 / (cos α)) + (175 * (tan α)) + (15.5 / (cos α)) + (T2 / (cos α) - (20 * (tan α)))
B	A - (83 * (tan α))
C1	(31 * (tan α)) + (T1 - 30.4) / (cos α) + (34 * (tan α))
C2	(T2 - 207.5) / (cos α) + (14 * (tan α))
E1	(T1 / (cos α)) + 15 + 80
E2	(T2 / (cos α)) - (20 * (tan α)) - (80 + 90)
F	L - (100 + (N * 49)) / (N + 1)

PROFIELEN / PROFILES / PROFILS / PROFILS			
TD021	1		L
TD022	1		L
TD023	1		L
VR190	2 x (N+1)		L - (100 + (N * 79)) / (N + 1)
TD025	1		L
TD011	N		A
TD012	M		A
GL041TD	(2xN) + M		B
TD171	2		HG
TD172	2		HG
TD211	N		C1
TD211	N		C2
TD225	1		L

(*) OPTIONEEL / OPTIONNEL / FAKULTATIV / OPTIONAL			
TD001	1		L - 220
VR224	1		L
ACVR2727			L/300

TOEBEHOREN / ACCESSOIRES / ZUBEHÖRTEILE / ACCESSORIES			
ACVR620	2 x (N+1)		(F - 30)
ACVR503	1		L
ACMC016	(2xN) + M		E
ACUN033	(2xN) + M		E
ACTD130	(2xN) + M		
(*) ACTD100	(2xN) + M		E
ACTD105	1		L
ACTD015	N		
ACTD012	M		
ACTD022	2		
(*) ACTD041	2		
ACTD220	2		
ACTD026	2		



## TD021 - TD111

DAKOVERSTEEK - DÉBORD DE TOIT - DACHÜBERSTAND - ROOF OVERHANG

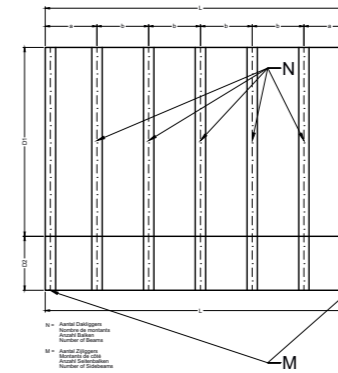
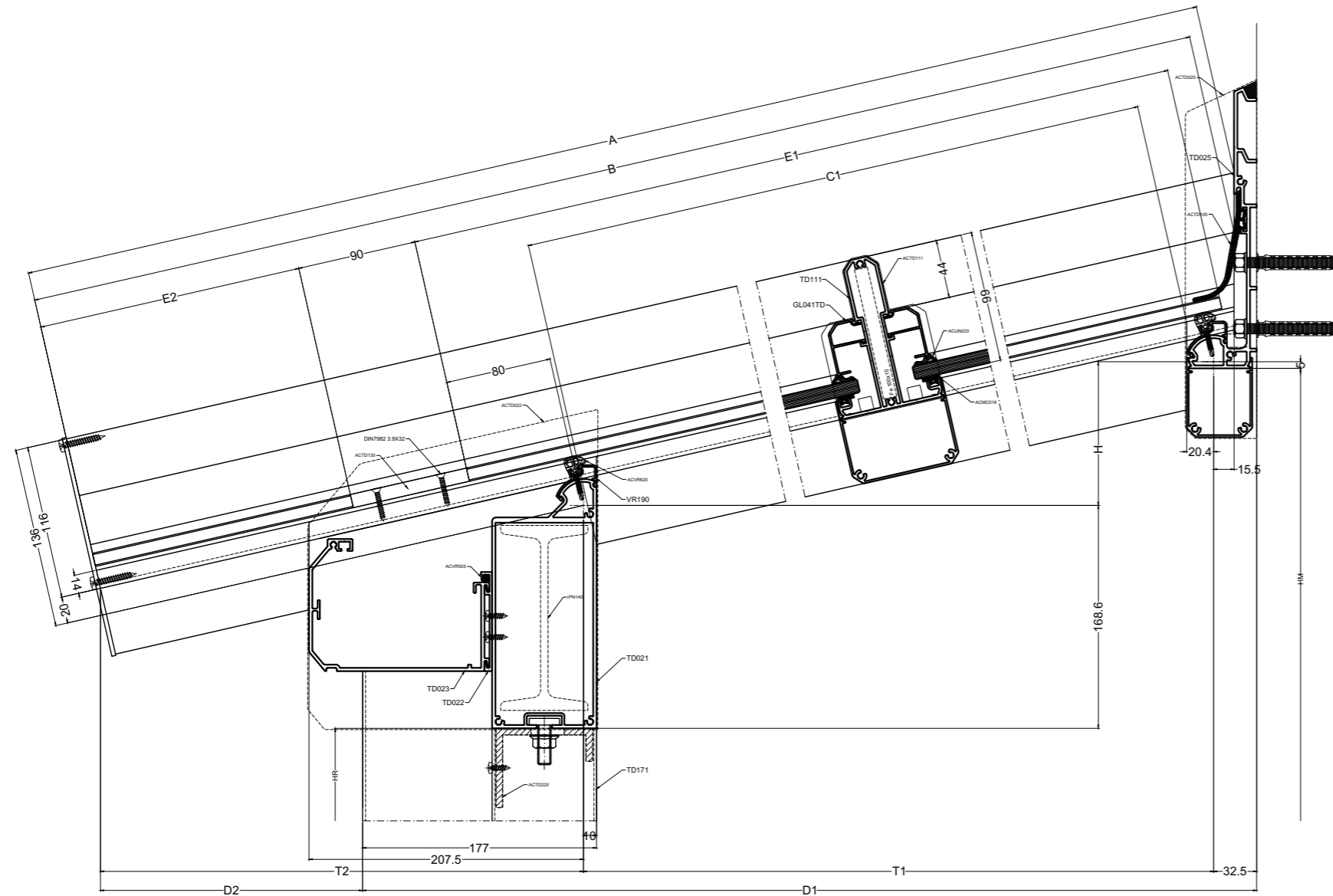

L	
D1	
D2	
H	$HM - (HR + 168.6) + 5$
T1	$D1 - (167 + 32.5)$
T2	$D2 + 167$
N	
M	
$\alpha$	ARCTAN (H/T)
A	$(T1 / (\cos \alpha)) + (136 * (\tan \alpha)) + (15.5 / (\cos \alpha)) + (T2 / (\cos \alpha) - (20 * (\tan \alpha)))$
B	$A - (44 * (\tan \alpha))$
C1	$(31 * (\tan \alpha)) + (T1 - 30.4) / (\cos \alpha) + (34 * (\tan \alpha))$
C2	$(T2 - 207.5) / (\cos \alpha) + (14 * (\tan \alpha))$
E1	$(T1 / (\cos \alpha)) + 15 + 80$
E2	$(T2 / (\cos \alpha)) - (20 * (\tan \alpha)) - (80 + 90)$
F	$L - (100 + (N * 43)) / (N + 1)$

### PROFIELEN / PROFILS / PROFILES / PROFILS

TD021		1		L
TD022		1		L
TD023		1		L
VR190		$2 \times (N+1)$		$L - (100 + (N * 79)) / (N + 1)$
TD025		1		L
TD111		N		A
TD112		M		A
GL041TD		$(2 \times N) + M$		B
TD171		2		HG
TD172		2		HG
TD211		N		C1
TD211		N		C2
TD225		1		L

### (\*) OPTIONEEL / OPTIONNEL / FAKULTATIV / OPTIONAL

TD001		1		L - 220
VR224		1		L
ACVR2727				L/300

### TOEBEHOREN / ACCESSOIRES / ZUBEHÖRTEILE / ACCESSORIES

ACVR620	$2 \times (N+1)$		(F - 36)
ACVR503	1		L
ACMC016	$(2 \times N) + M$		E
ACUN033	$(2 \times N) + M$		E
ACTD130	$(2 \times N) + M$		
(*) ACTD100	$(2 \times N) + M$		E
ACTD105	1		L
ACTD115	N		
ACTD112	M		
ACTD022	2		
(*) ACTD041	2		
ACTD220	2		
ACTD026	2		



**TD020 - TD011**

NOK - TOIT À PIGNON - SATTELDACH - GABLE ROOF

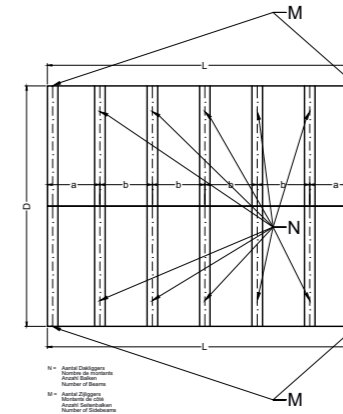
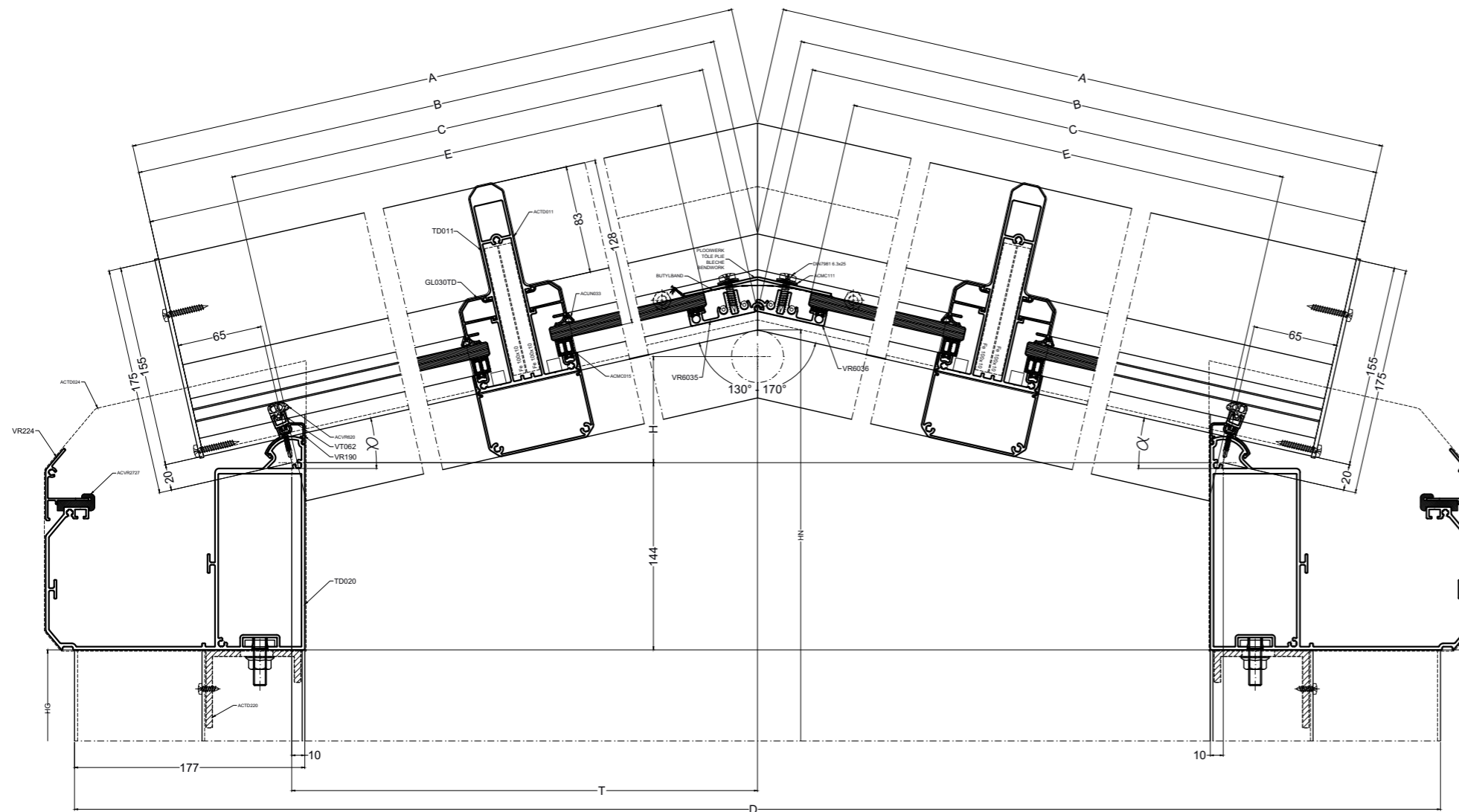

L	
D	
H	$HN - (HG + 144) + (20 / \cos \alpha)$
T	$D / 2 - 167$
N	
M	
$\alpha$	ARCTAN (H/T)
A	$(T / \cos \alpha) + (175 \cdot \tan \alpha) + 65$
B	$A - (83 \cdot \tan \alpha)$
C	$(31 \cdot \tan \alpha) + ((T - 10) / \cos \alpha) + ((34 \cdot \tan \alpha))$
E	$A - (175 \cdot \tan \alpha) - 29.5$
F	$L - (100 + (N \cdot 49)) / (N + 1)$

PROFIELEN / PROFILES / PROFILI / PROFILS

TD020		2	L
VR190		2 x (N+1)	$L - (100 + (N \cdot 79)) / (N + 1)$
VT062		2 x (N+1)	$L - (100 + (N \cdot 79)) / (N + 1)$
VR6035		1	L - 80
VR6036		1	L - 80
TD011		N	A
TD012		M	A
GL030TD		(2xN) + M	B
TD171		4	HG
TD172		4	HG

(\*) OPTIONEEL / OPTIONNEL / FAKULTATIV / OPTIONAL

TD211		N	C
TD001		2	L - 220
VR224		2	L
ACVR2727			L/300

TOEBEHOREN / ACCESSOIRES / ZUBEHOORTEILE / ACCESSORIES

ACVR620	2 x (N+1)	(F - 30)
ACMC015	(2xN) + M	E
ACMC015	2 x (N+1)	(F - 30)
ACUN033	(2xN) + M	E
(*) ACTD100	(2xN) + M	E
ACTD105	1	L
ACTD011	N	
ACTD012	M	
ACTD020	4	
(*) ACTD024	4	
ACTD220	4	

## TD020 - TD011

SOLARDAK - TOITURE SOLAR - SOLARDACH - SOLAR ROOF

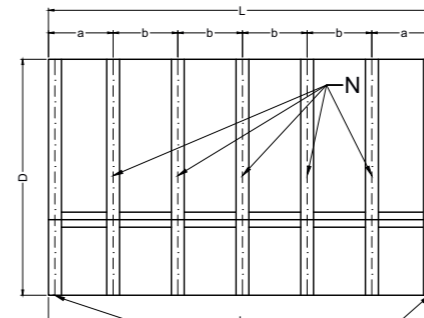
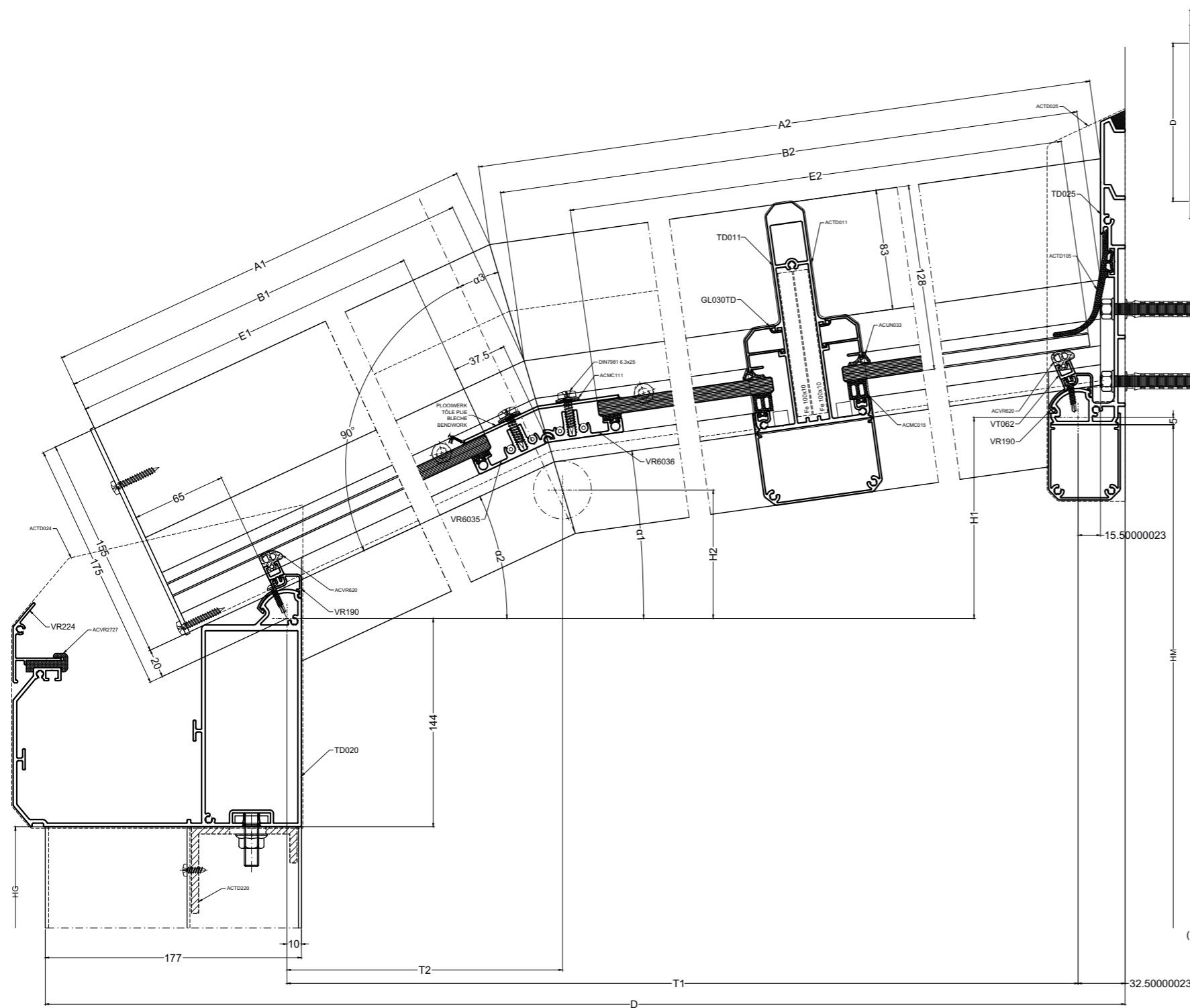

N = Anzahl Zylinder  
Number of cylinders  
Anzahl Zylinder  
M = Anzahl Zylinder  
Number of cylinders  
Anzahl Zylinder

L	
D	
H1	$HM - (HG + 144) + 5$
H2	$(H1 / 3) * 2$
T1	$D - (167 + 32.5)$
T2	$H2 / (\tan \alpha 2)$
N	
M	
$\alpha 1$	$\text{ARCTAN } (H1 - H2) / T1 - T2$
$\alpha 2$	$\text{ARCTAN } (H2 / T2)$
$\alpha 3$	$(\alpha 2 - \alpha 1) / 2$
A1	$(T2 / (\cos \alpha 2)) + (175 * (\tan \alpha 3)) + 65$
A2	$((T1 - T2) / (\cos \alpha 1)) + (175 * (\tan \alpha 1)) + ((15.5 / (\cos \alpha 1)))$
B1	$A1 - (83 * (\tan \alpha 3))$
B2	$A2 - (83 * (\tan \alpha 3)) - (83 * (\tan \alpha 1))$
C1	$((31 * (\tan \alpha 2)) + ((T2 - 10) / (\cos \alpha 2)) + ((34 * (\tan \alpha 3)))$
C2	$((31 * (\tan \alpha 3)) + ((T1 - T2) - 30.4) / (\cos \alpha 1)) + ((34 * (\tan \alpha 1)))$
E1	$((T2 / (\cos \alpha 2)) + ((34 * (\tan \alpha 3)) - 37.5 + 65$
E2	$((T1 - T2) / (\cos \alpha 1)) + (34 * (\tan \alpha 3)) + (34 * (\tan \alpha 1)) + ((15.5 / (\cos \alpha 1)) - 37.5$
F	$L - (100 + (N * 49)) / (N + 1)$

### PROFIELN / PROFILES / PROFILS / PROFILS

TD020		1		L
VR190		2 x (N+1)		$L - (100 + (N * 79)) / (N + 1)$
VT062		2 x (N+1)		$L - (100 + (N * 79)) / (N + 1)$
VR6035		(N+1)		F
VR6036		(N+1)		F
TD025		1		L
TD011		N		A1
TD011		N		A2
TD012		M		A1
TD012		M		A2
GL030TD		(2xN) + M		B1
GL030TD		(2xN) + M		B2
TD171		2		HG
TD172		2		HG

### (\*) OPTIONEEL / OPTIONNEL / FAKULTATIV / OPTIONAL

TD211		N		C1
TD211		N		C2
TD001		1		L - 220
VR224		1		L
ACVR2727				L/300

### TOEBEHOREN / ACCESSOIRES / ZUBEHÖRTEILE / ACCESSORIES

ACVR620	2 x (N+1)		(F - 30)
ACMC015	(2xN) + M		E1 - 15
ACMC015	(2xN) + M		E2 - 15
ACMC015	2 x (N+1)		(F - 30)
ACUN033	(2xN) + M		B1
ACUN033	(2xN) + M		B2
(*) ACTD100	(2xN) + M		E1 + E2
ACTD105	1		L
ACTD011	N		
ACTD012	M		
ACTD020	4		
(*) ACTD024	4		
ACTD220	4		

TD020-TD011-WALM

PAALAANSLUITING AAN GOOT EN RINGBALK  
 CONNEXION ENTRE POTEAU ET GOUTTIÈRE OU POUTRE D'ANNEAU  
 STÜTZENANSCHLUSS AN RINNE UND UNTERZUG  
 CONNEXION BETWEEN POST AND GUTTER OR RINGBEAM

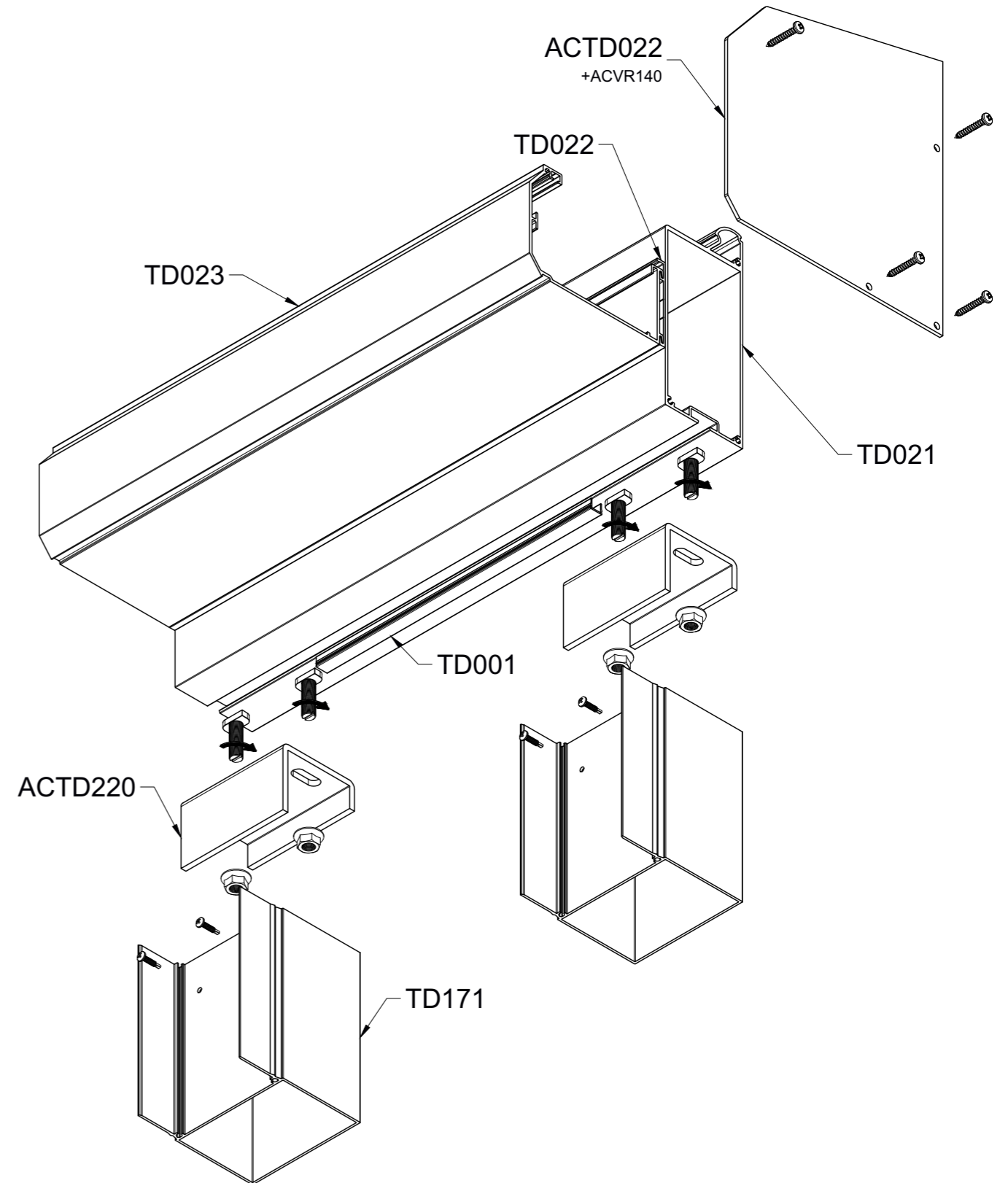
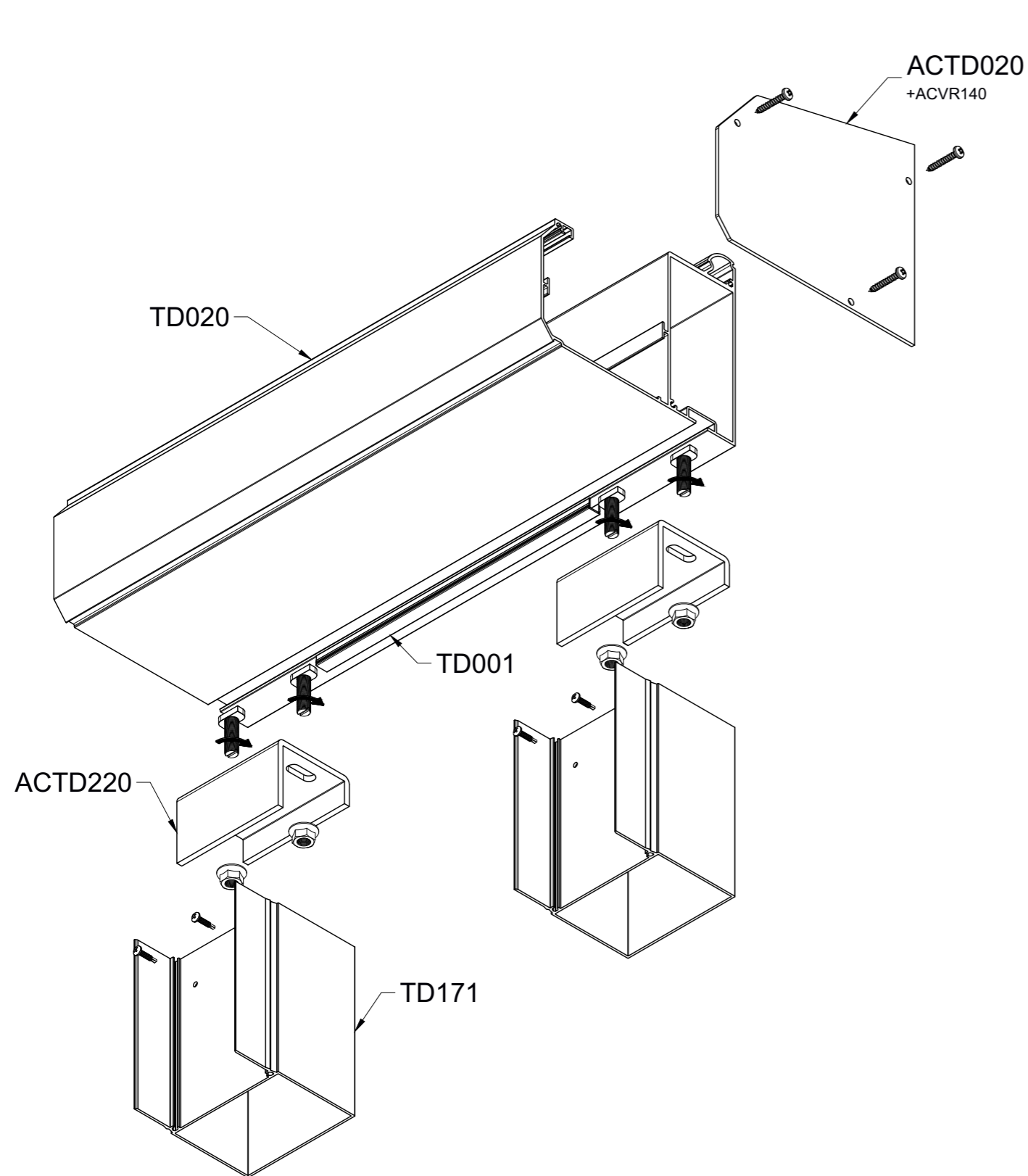

# TD Terrassendach

PAALBEKLEDING  
RECOUVREMENT POTEAU  
STÜTZENVERKLEIDUNG  
COVERING POST

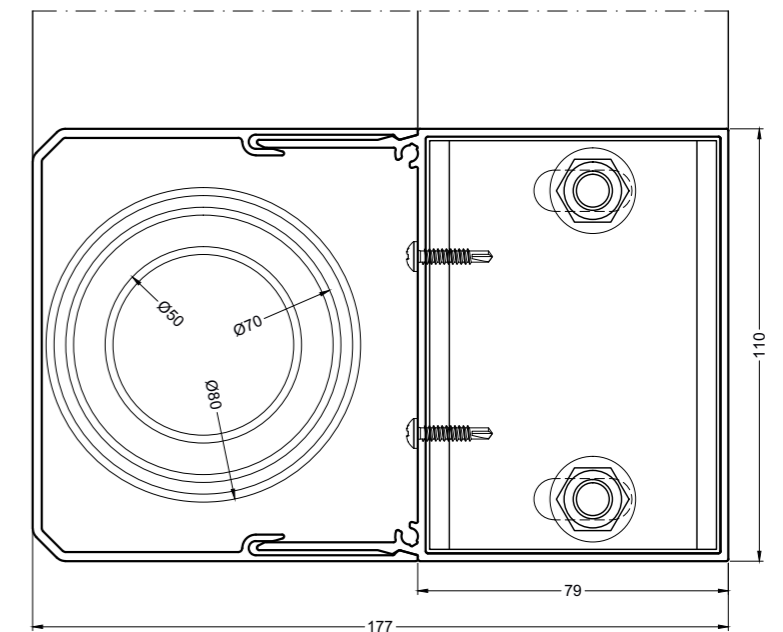
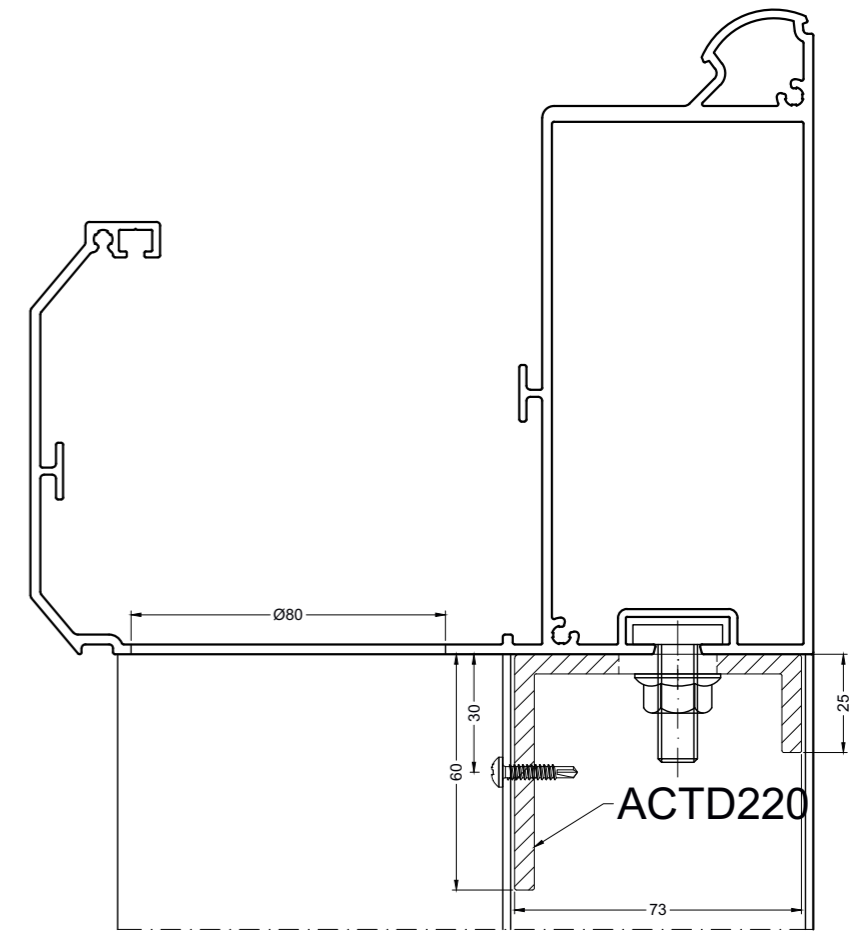
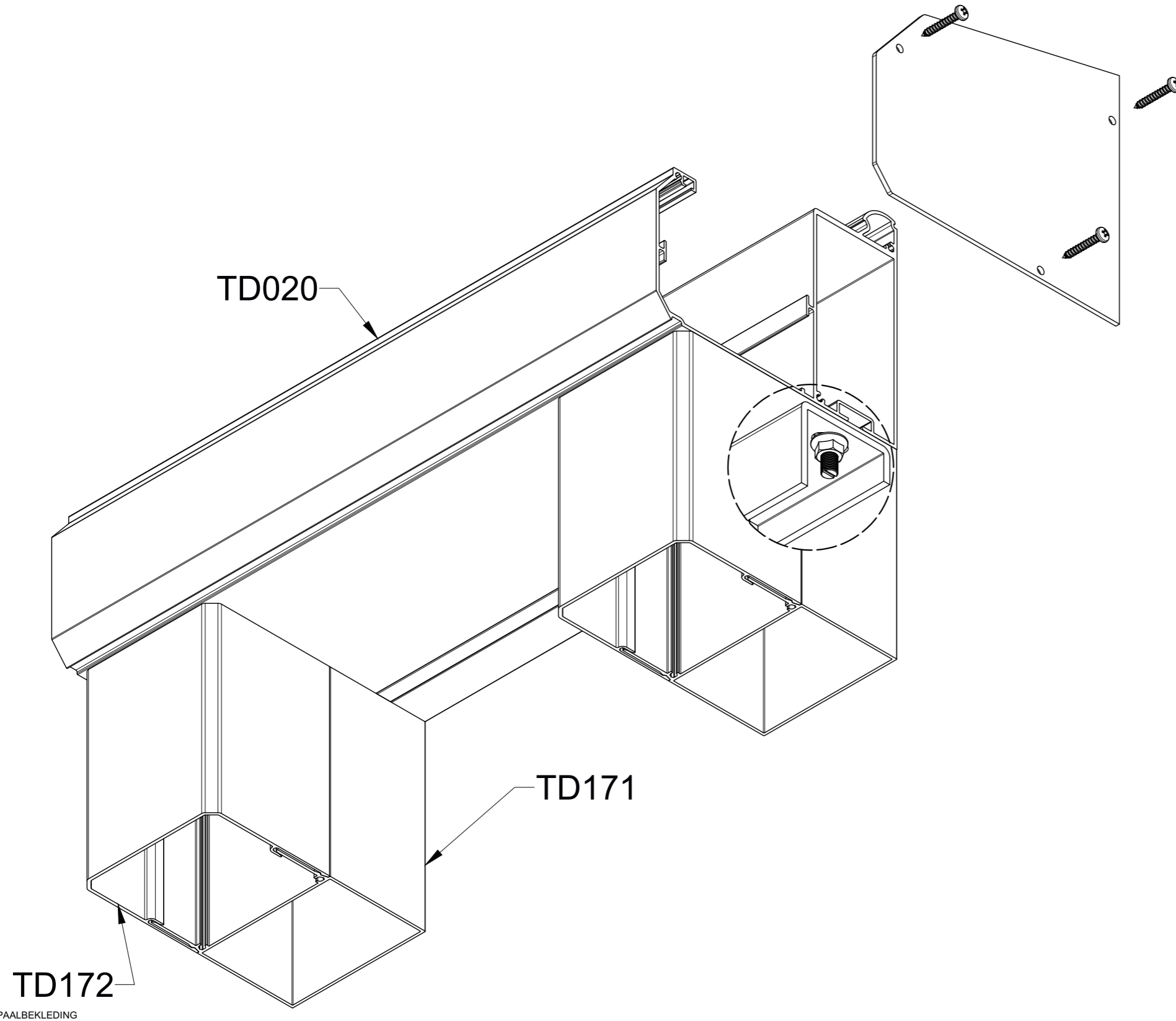

TD172  
PAALBEKLEDING

PAALBEKLEDING  
RECOUVREMENT POTEAU  
STÜTZENVERKLEIDUNG  
COVERING POST

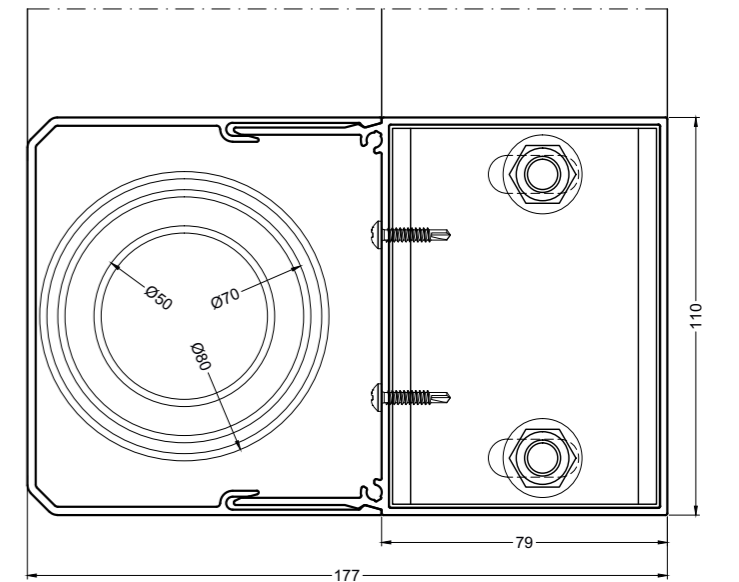
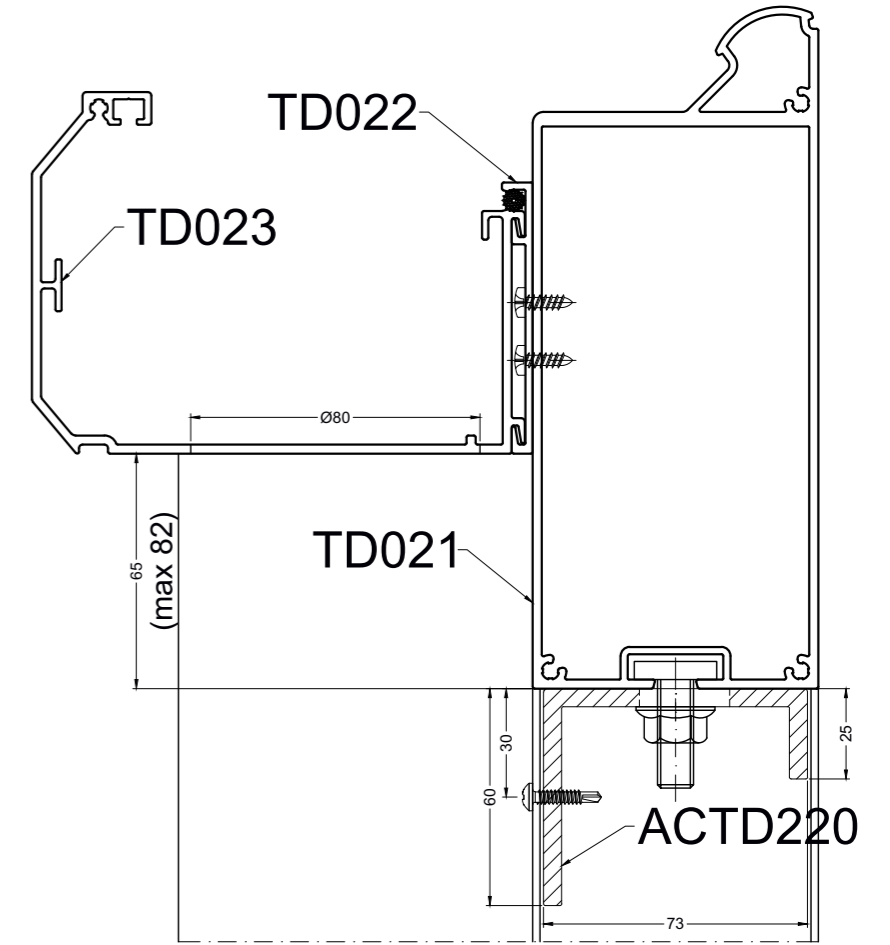
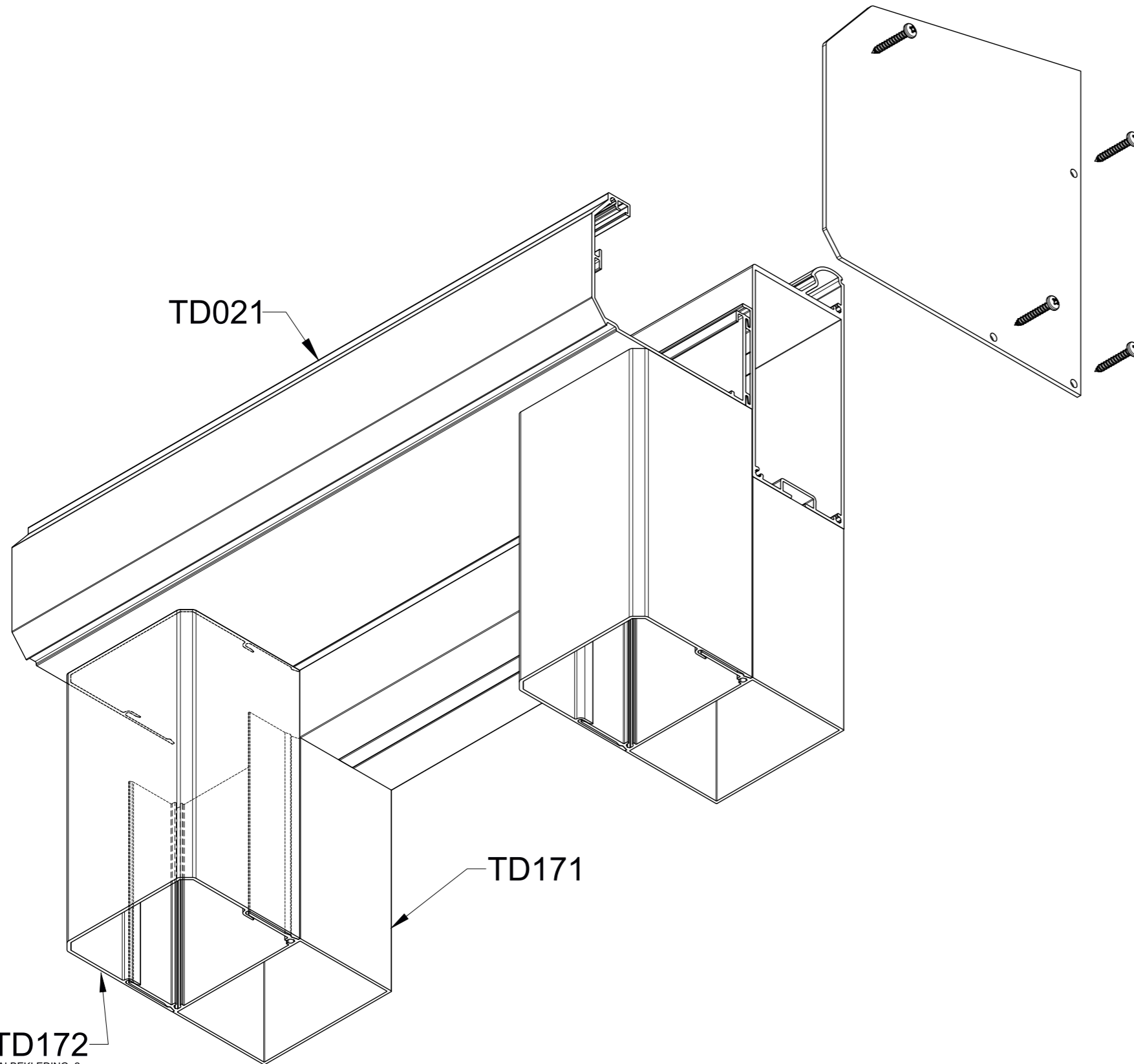

# TD Terrassendach

GOOTVERBINDING - AANTREKSTUK  
 CONNEXION GOUTTIERE - PIÉCE DE SERRAGE  
 RINNENVERBINDUNG - RINNENSPELLER  
 GUTTER CONNECTION - CLAMPING PIECE

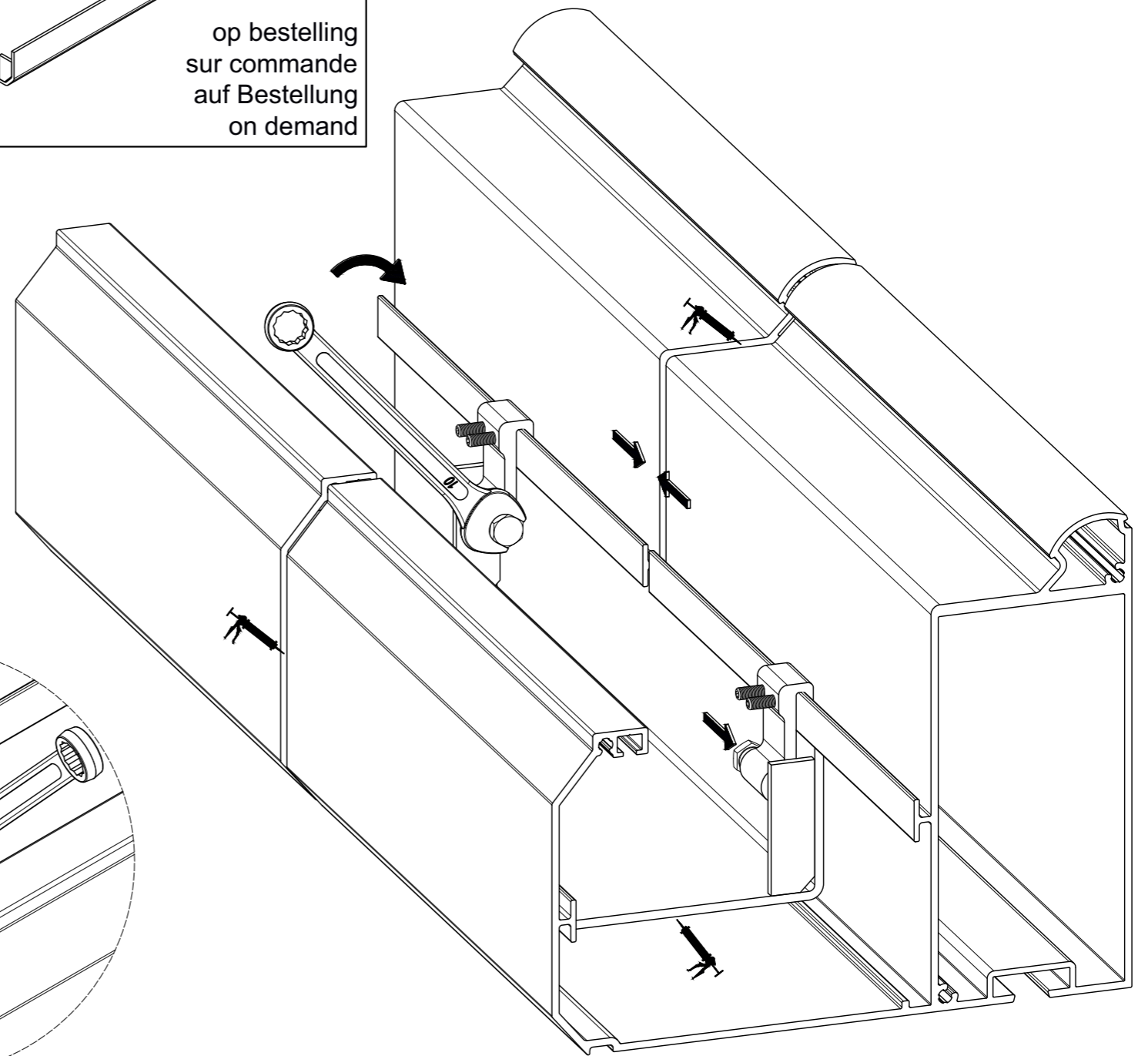
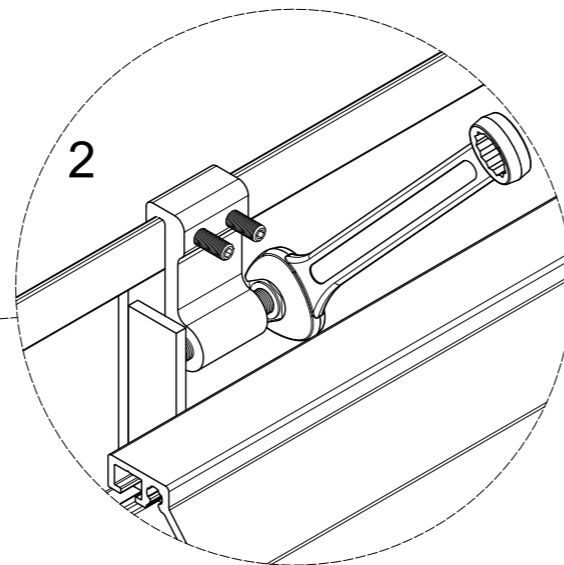
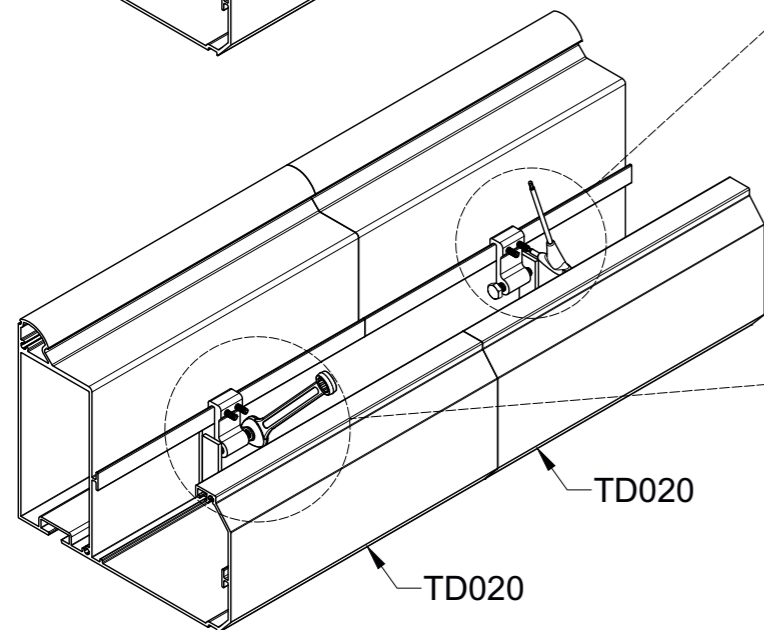
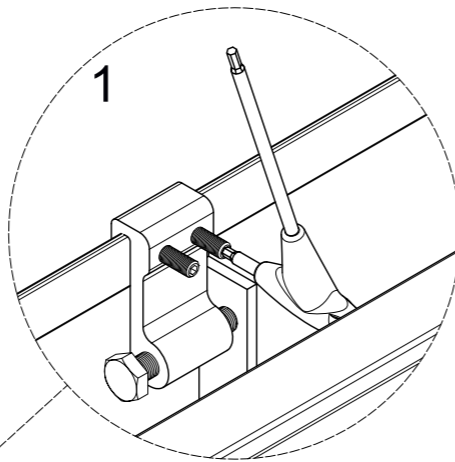
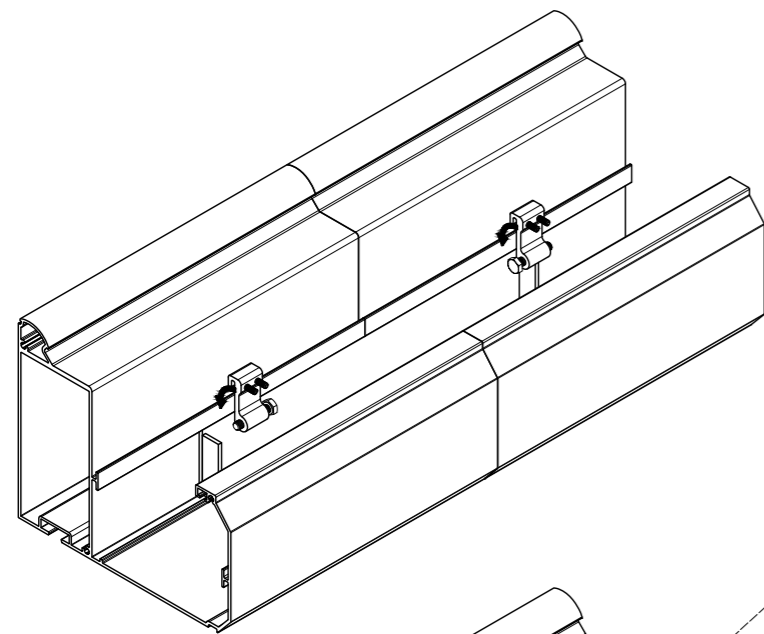
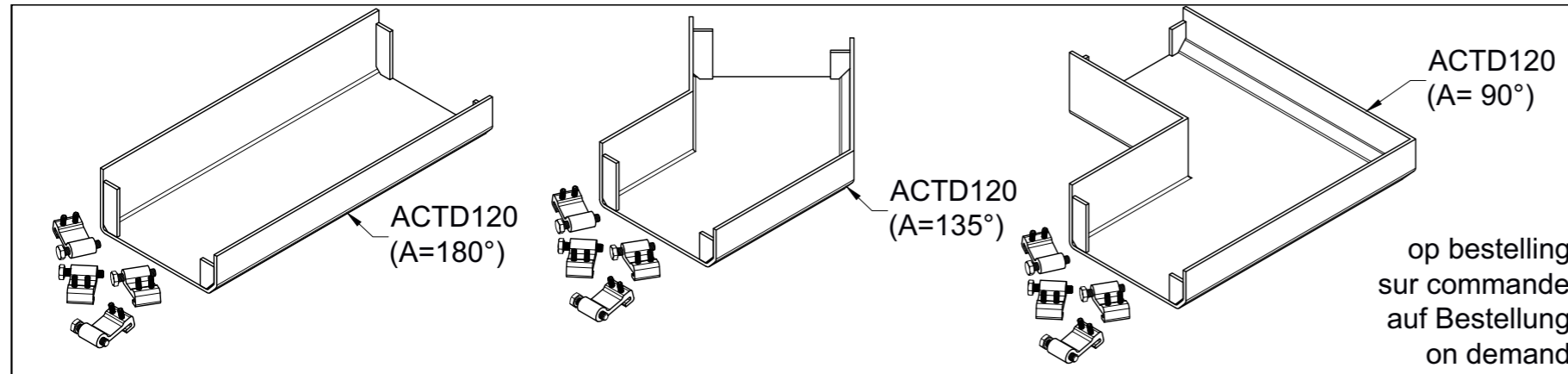

RINNENVERBINDER

GOOTVERBINDING - ACTD125  
 CONNEXION GOUTTIERE - ACTD125  
 RINNENVERBINDUNG - ACTD125  
 GUTTER CONNECTION - ACTD125

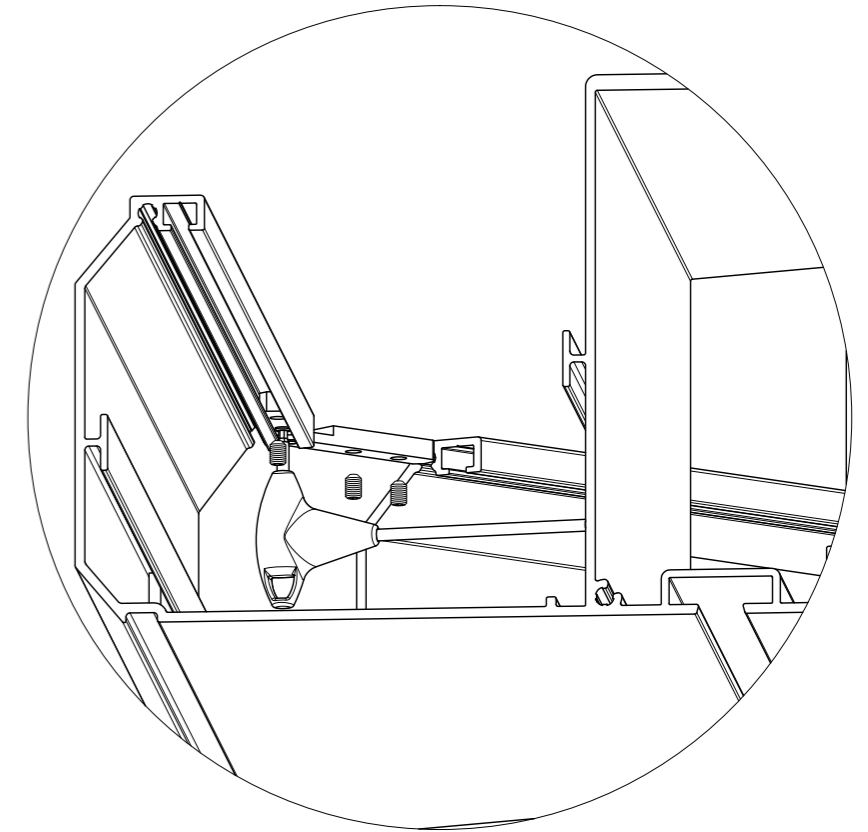
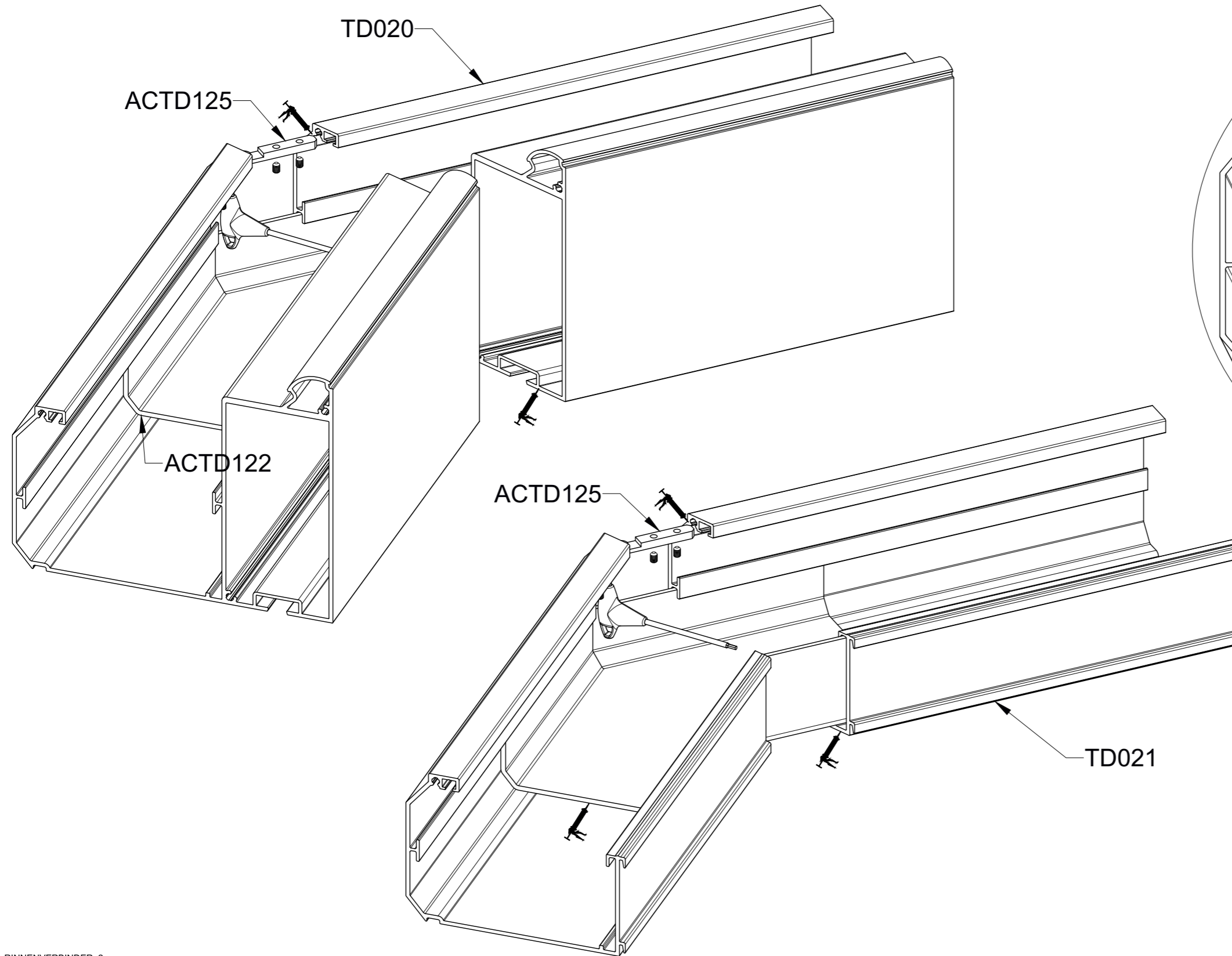

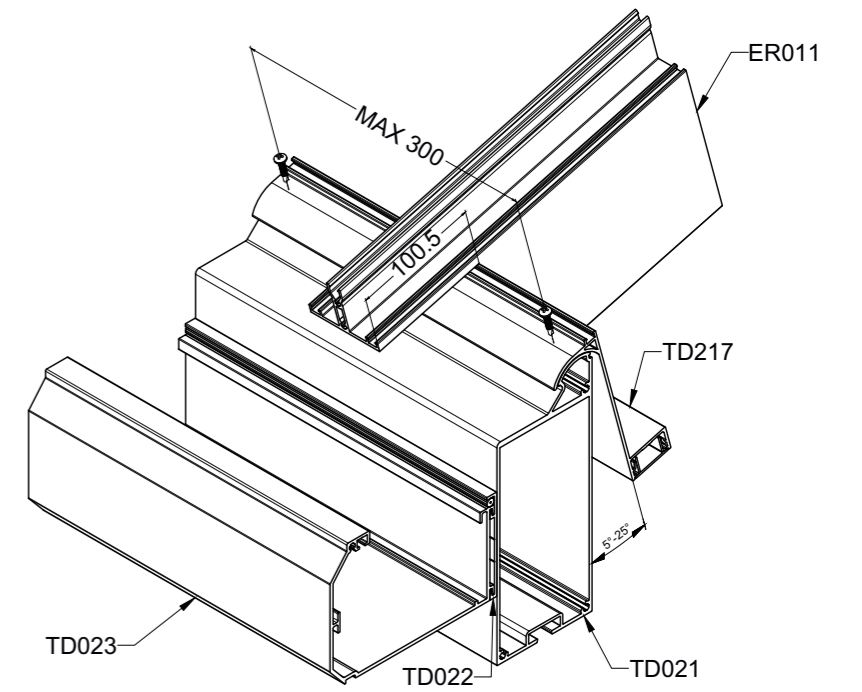
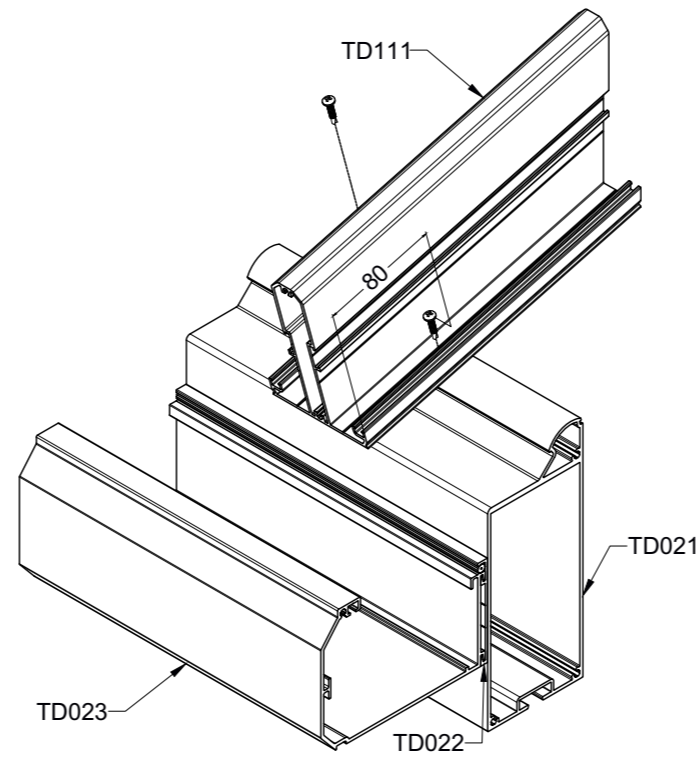
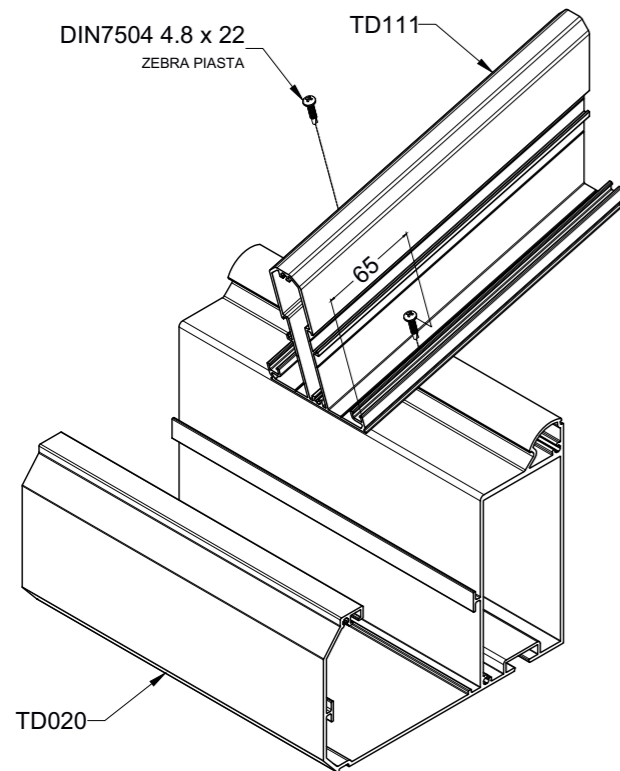
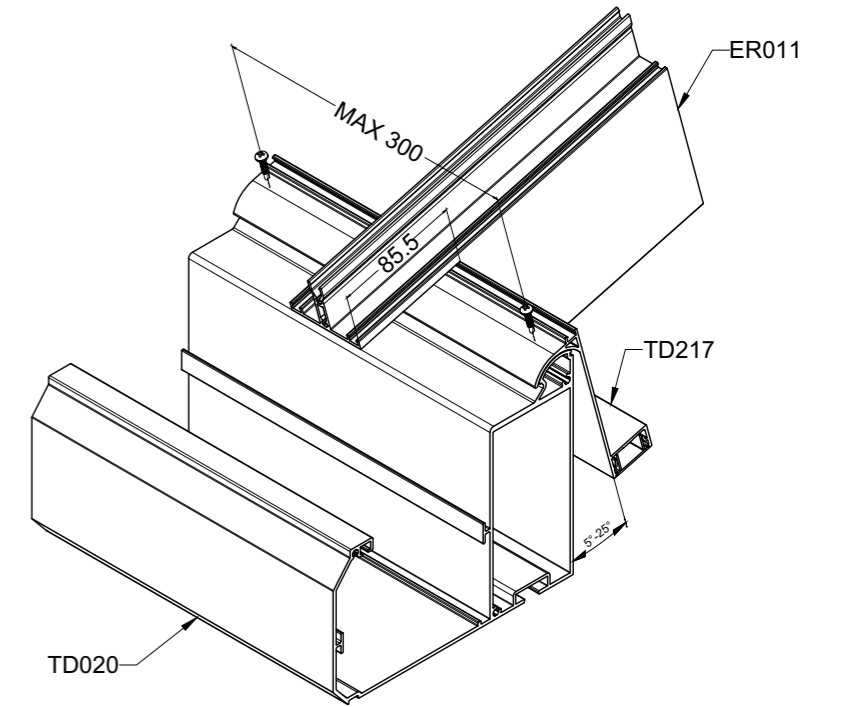
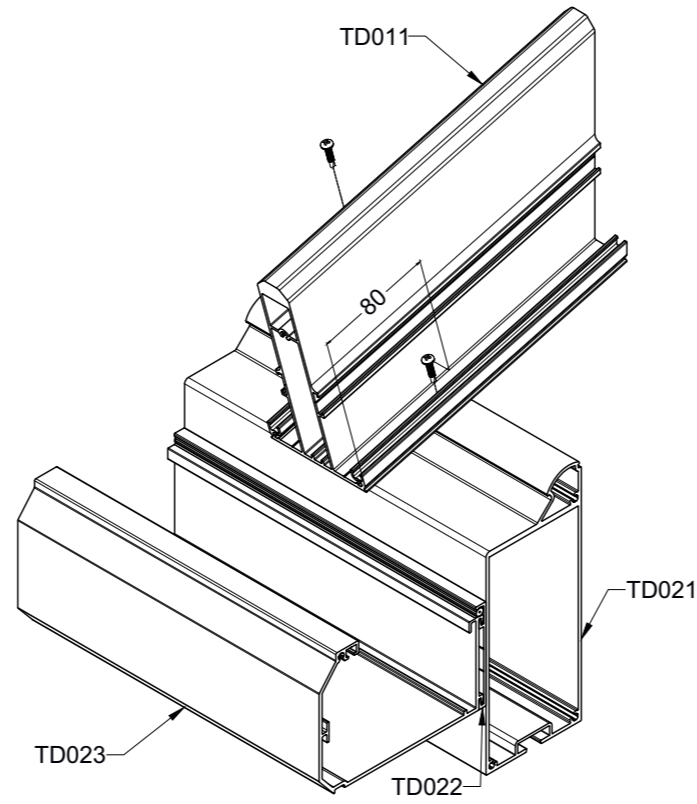
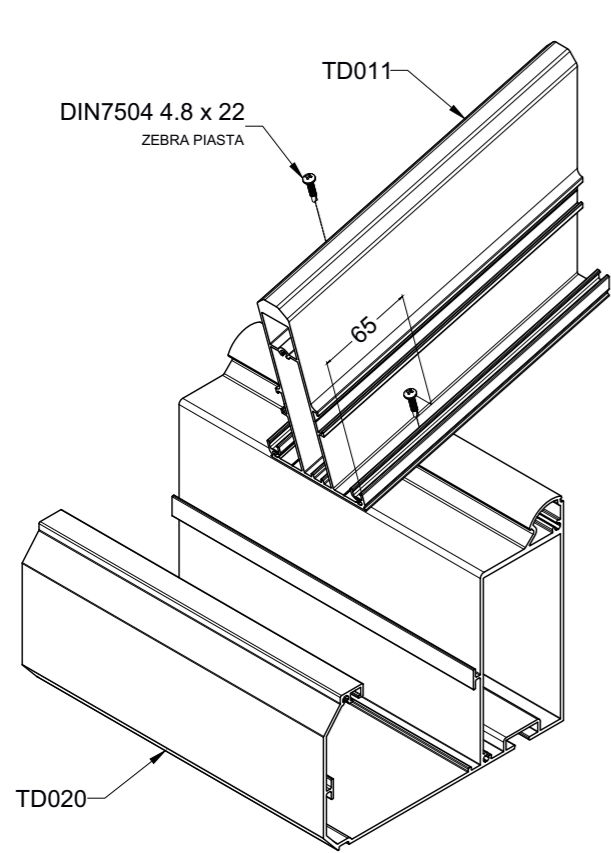

BEVESTIGING\_LIGGERS



BEVESTIGING LIGGERS  
FIXATION CHEVRONS  
BEFESTIGUNG SPARREN  
FIXATION RAFTERS

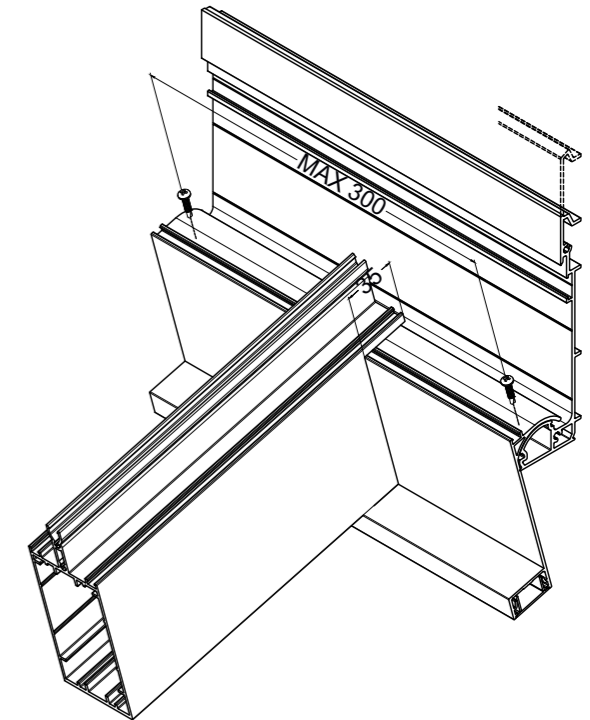
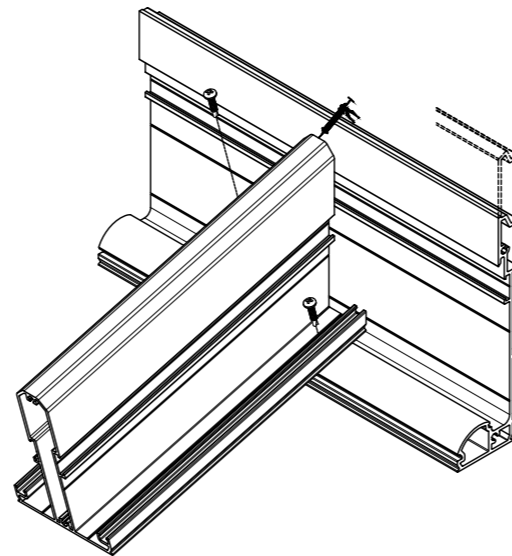
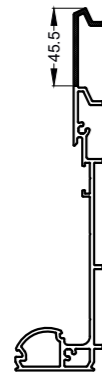
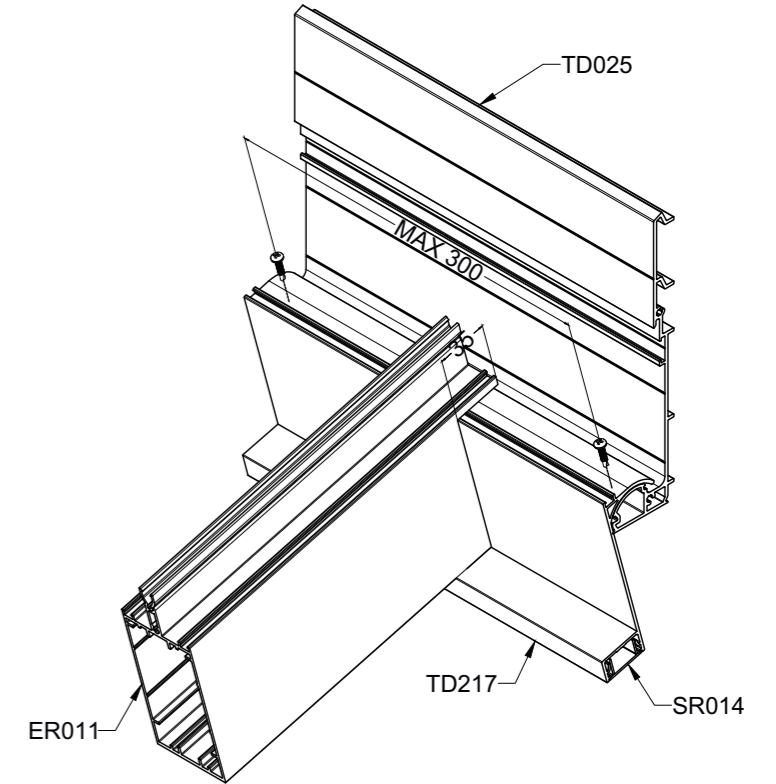
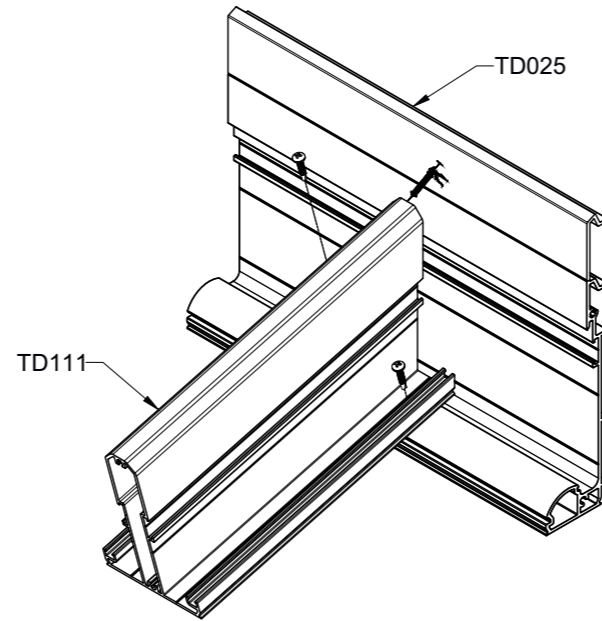
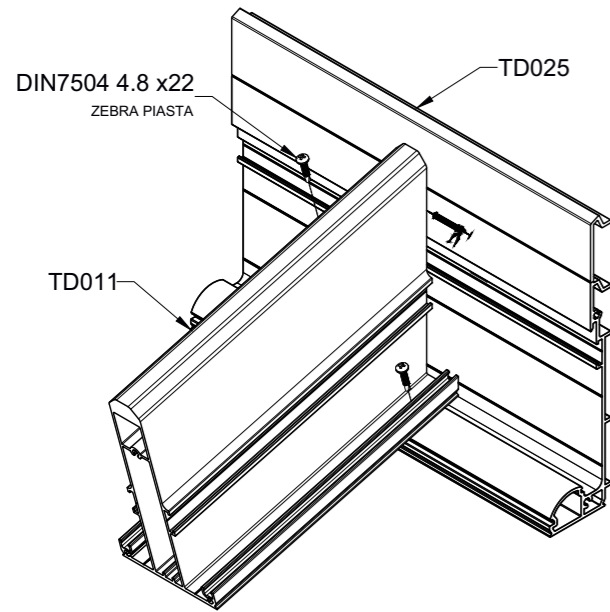

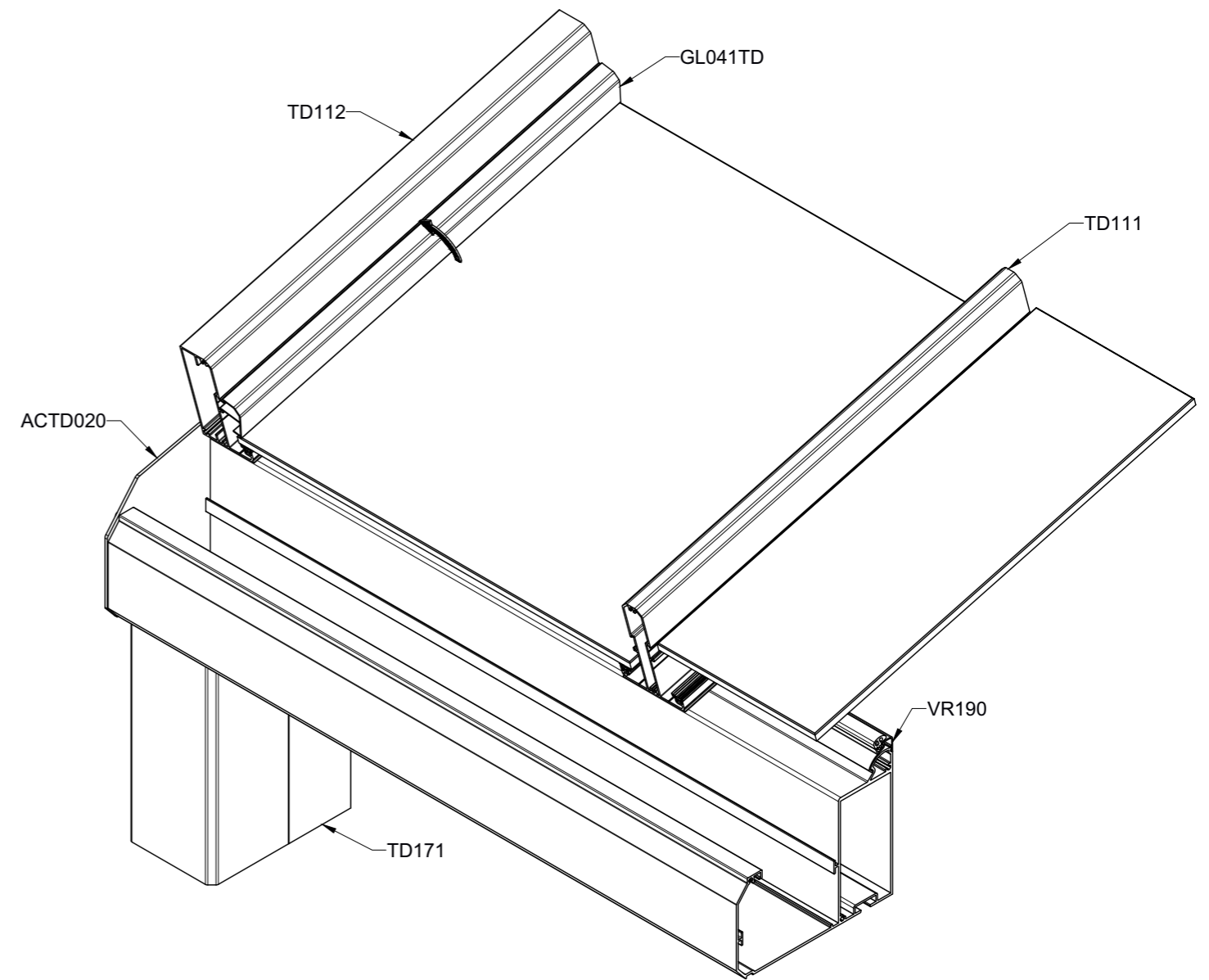
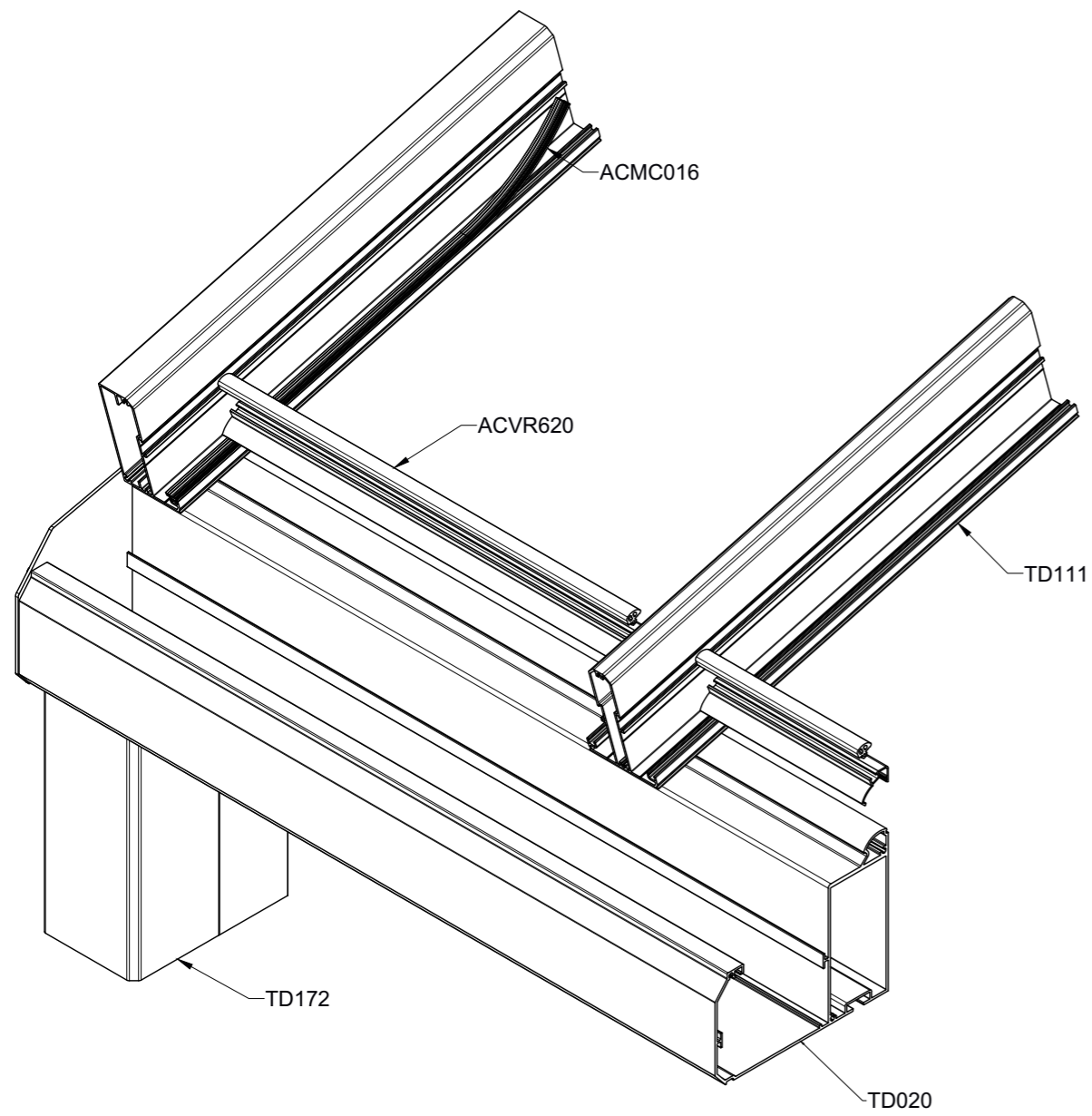

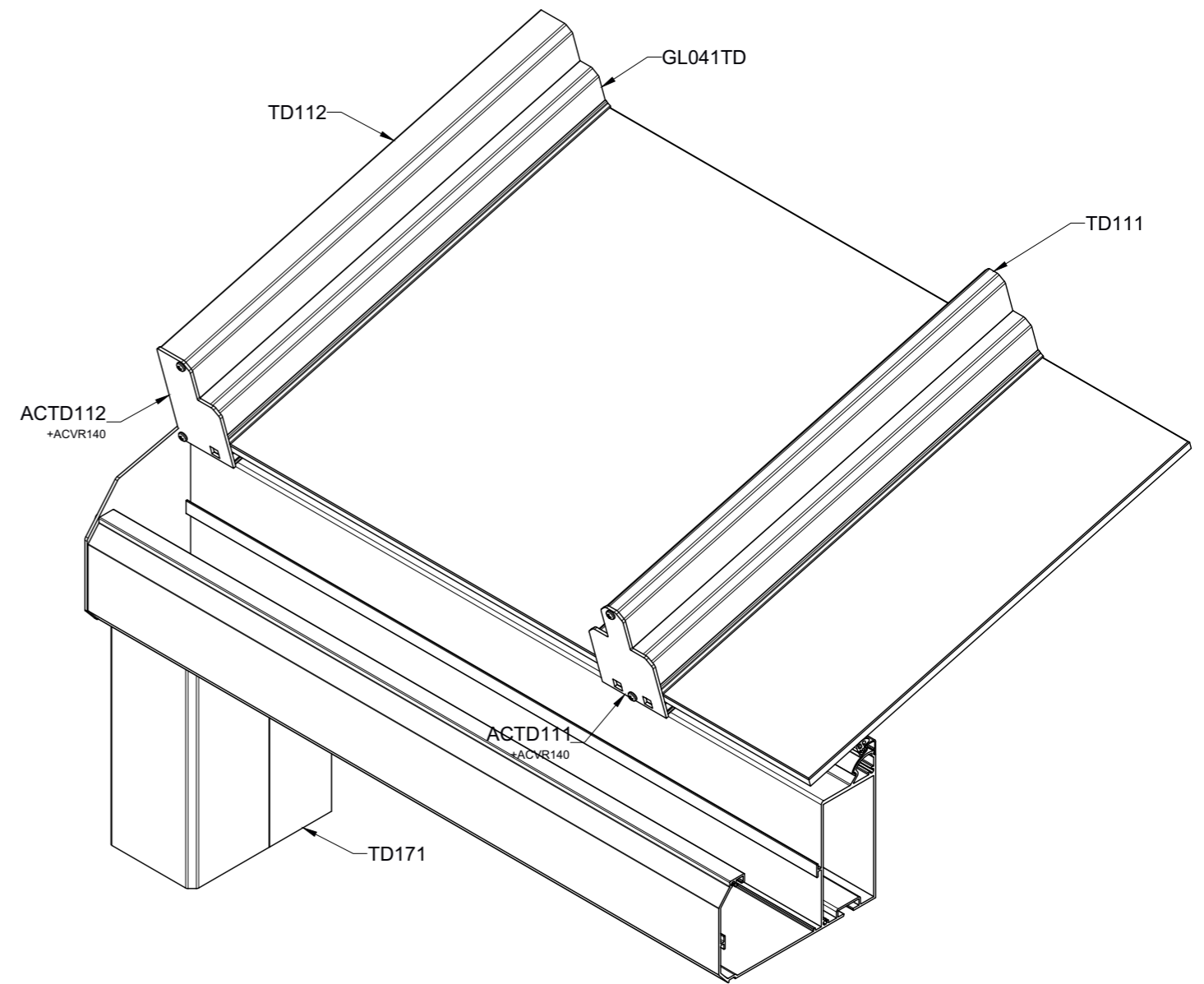
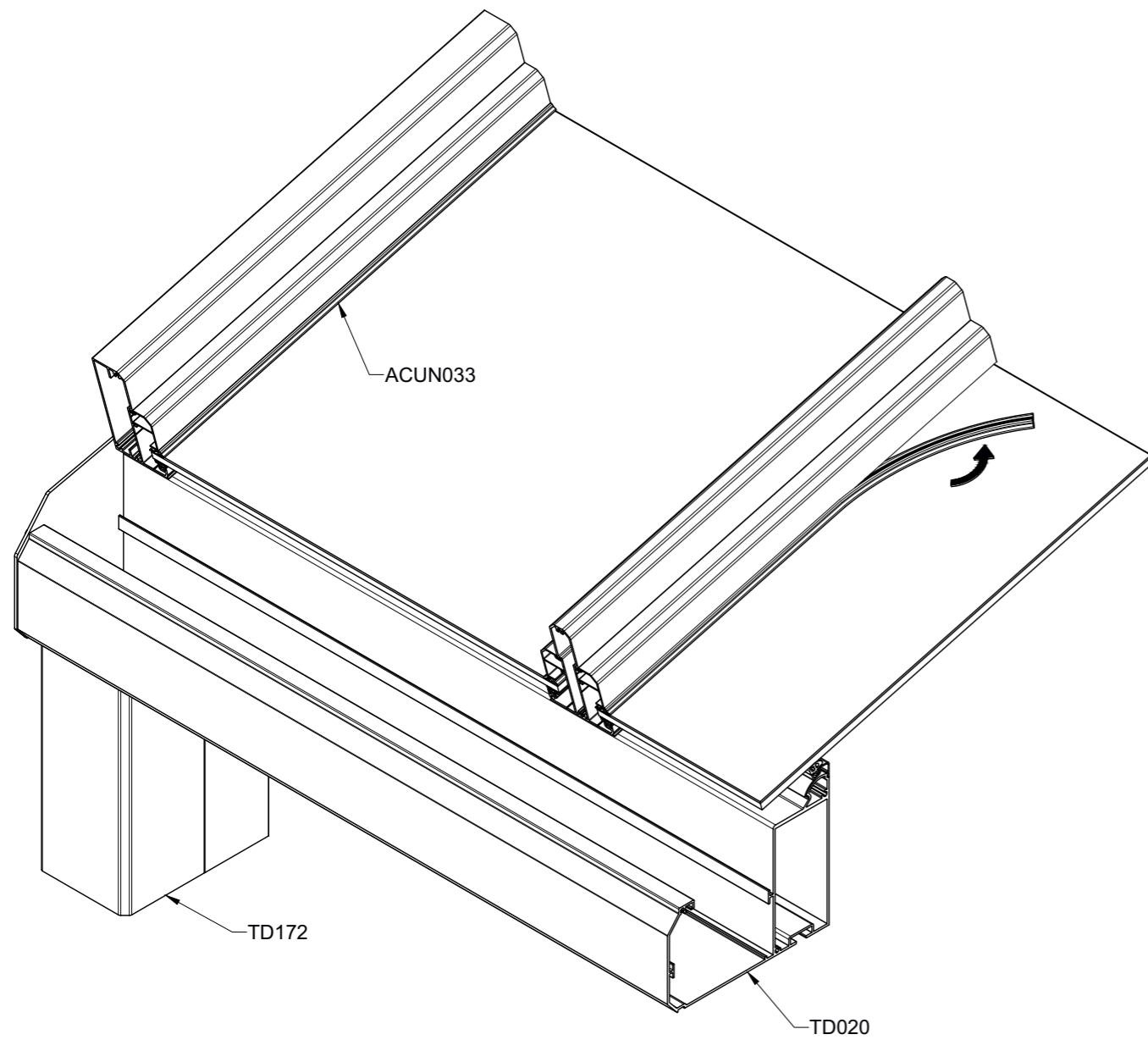

# TD Terrassendach

GELASTE NOKVERBINDING / WALMDAK  
CONNECTION SOUDÉ POUR TOIT À PIGNON / TOPAZE  
GESCHWEISTE VERBINDUNG FÜR SATTELDACH / WALMDACH  
WELDED CONNECTION FOR GABLE ROOF

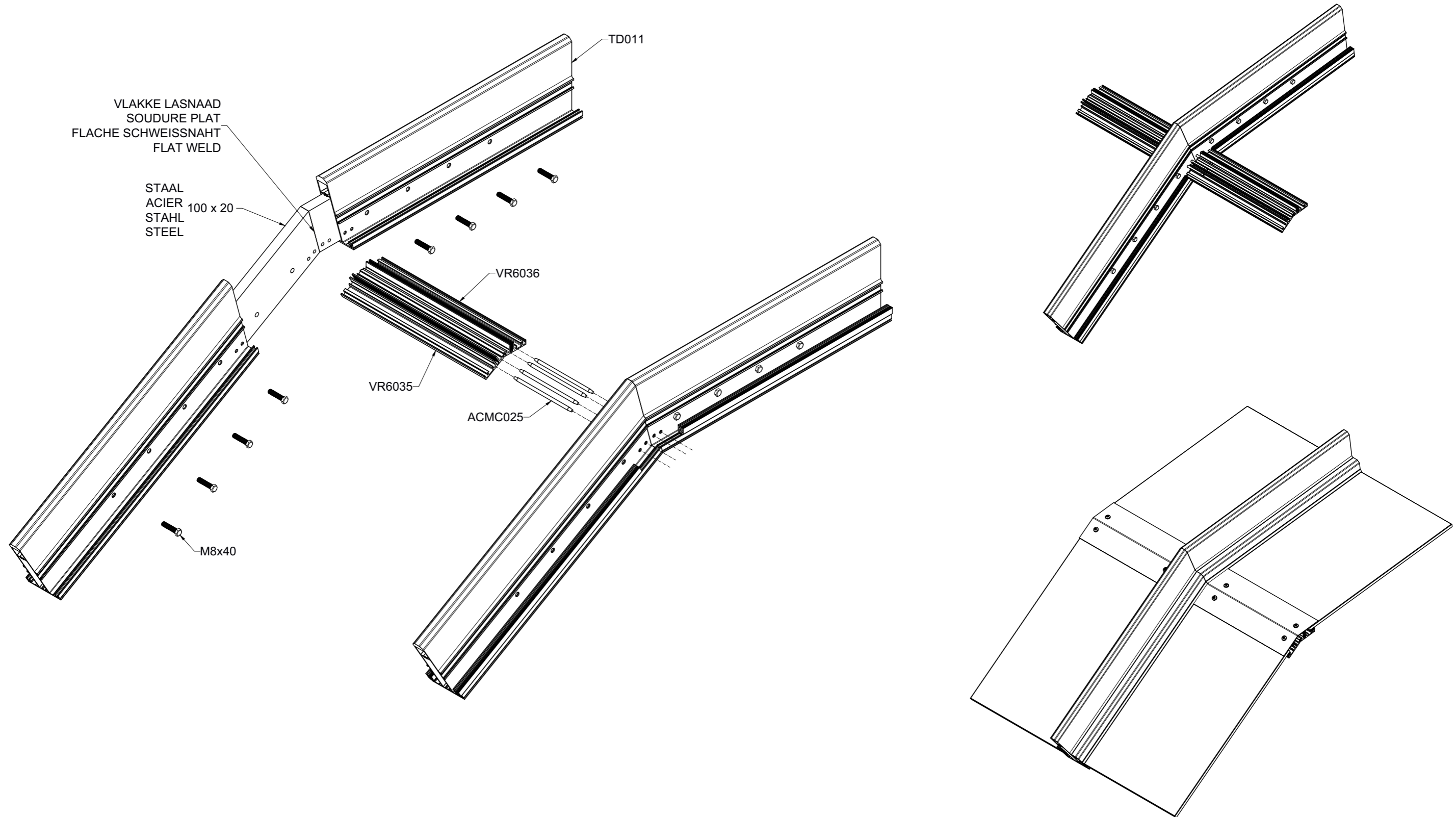

STAHLVERBINDUNG

MONTAGE VAN DE KABELGOTEN  
 MONTAGE DES PROFILS DE RECOUVREMENT  
 MONTAGE DES KABELKANALS  
 ASSEMBLING THE WIREWAY PROFILES

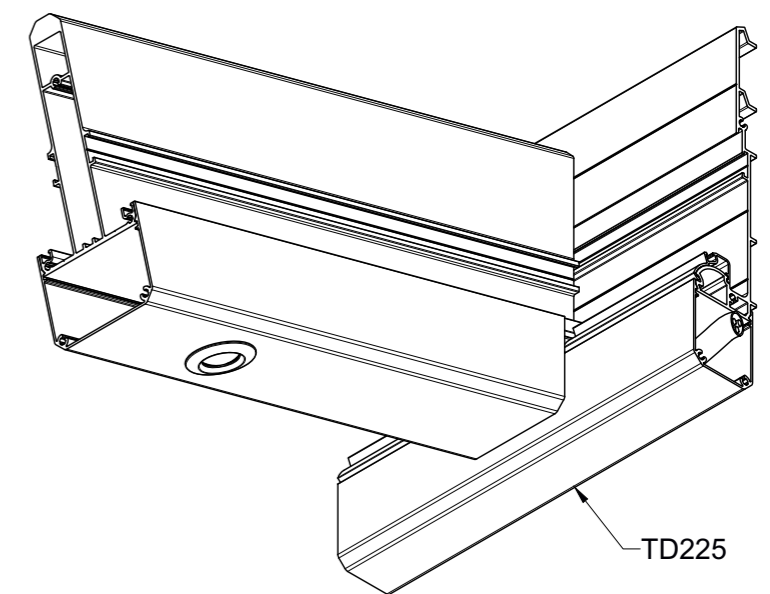
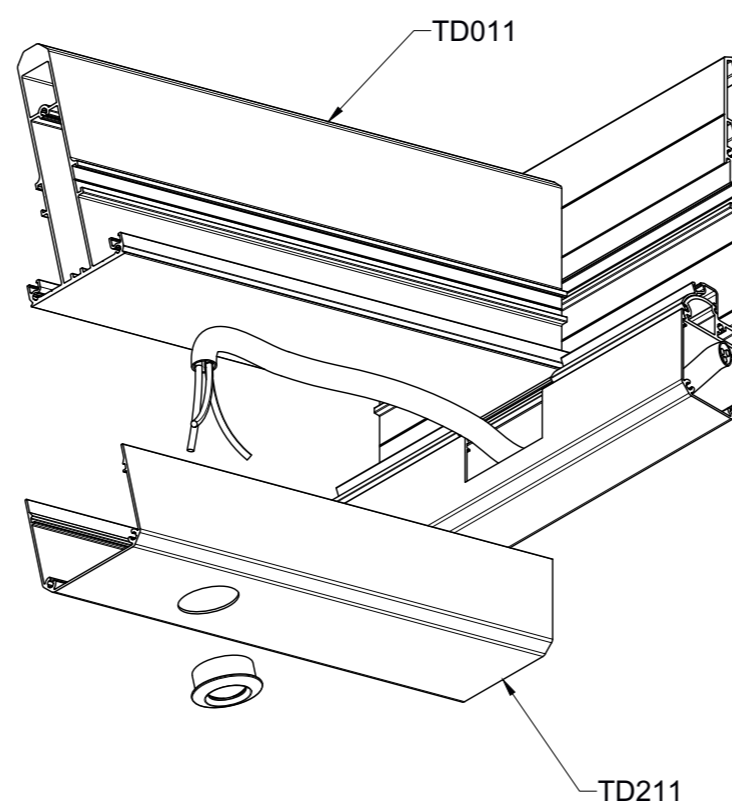
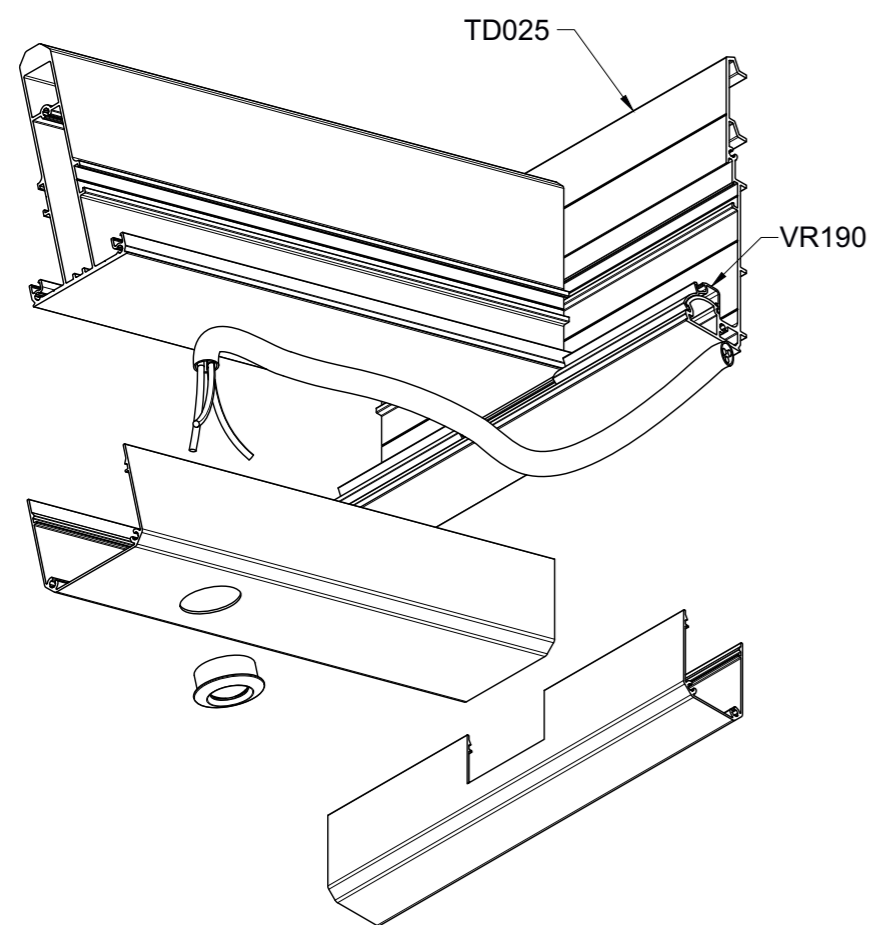

# TD Terrassendach

GLASOVERSTEEK - VARIABLE GOOT  
DÉBORD DE TOIT - GOUTTIERE VARIABLE  
DACHÜBERSTAND - VARIABLE RINNE  
ROOF OVERSTAND - VARIABLE GUTTER

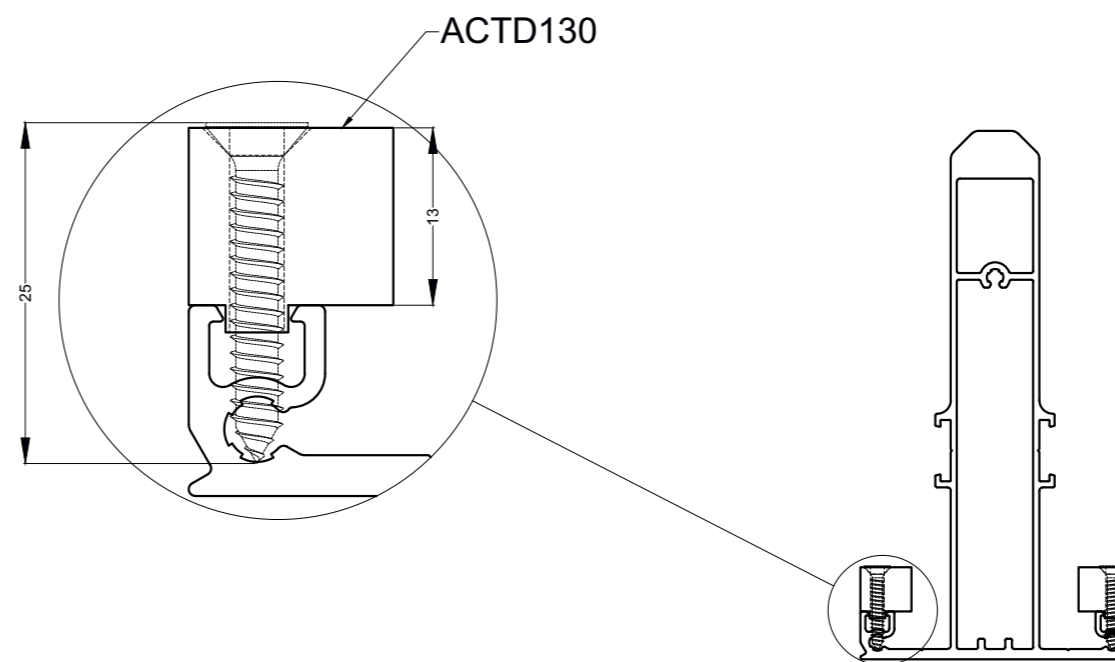
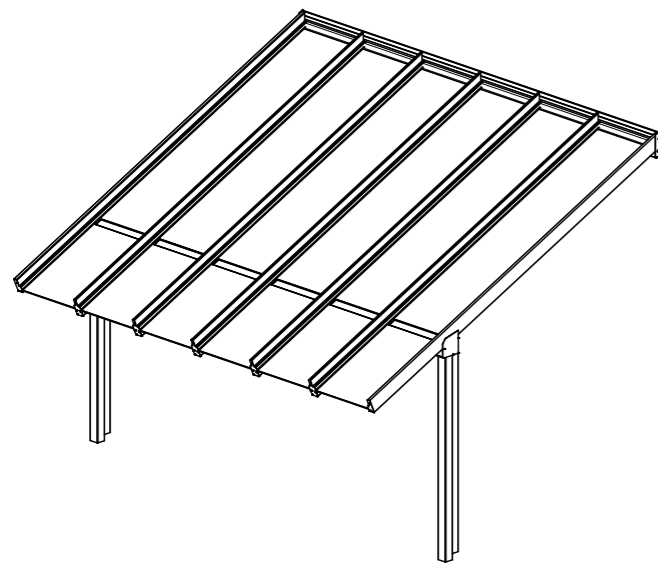
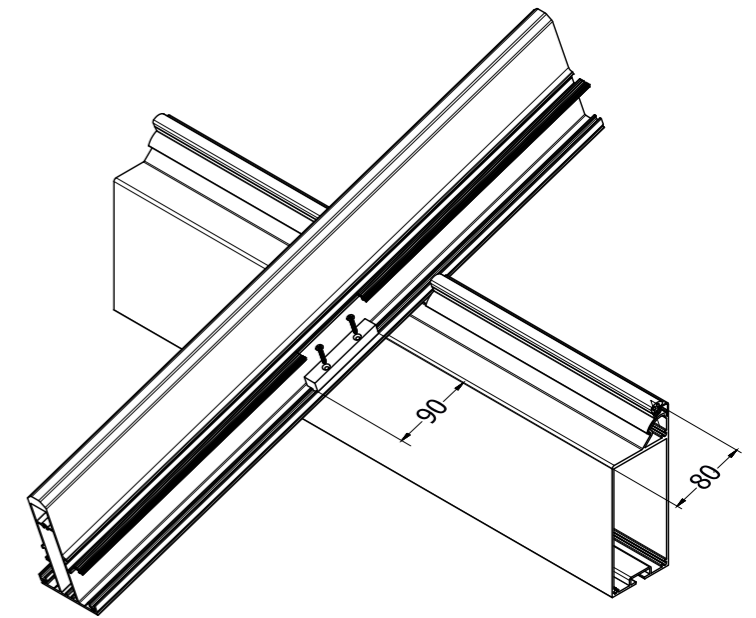
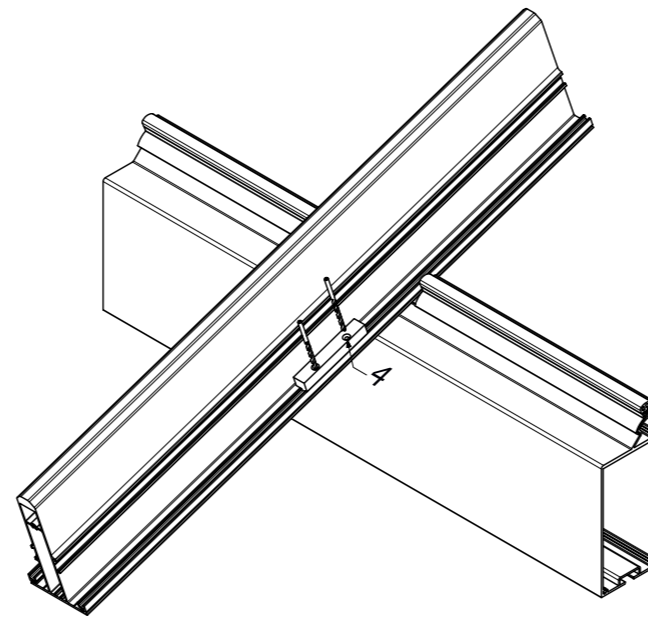
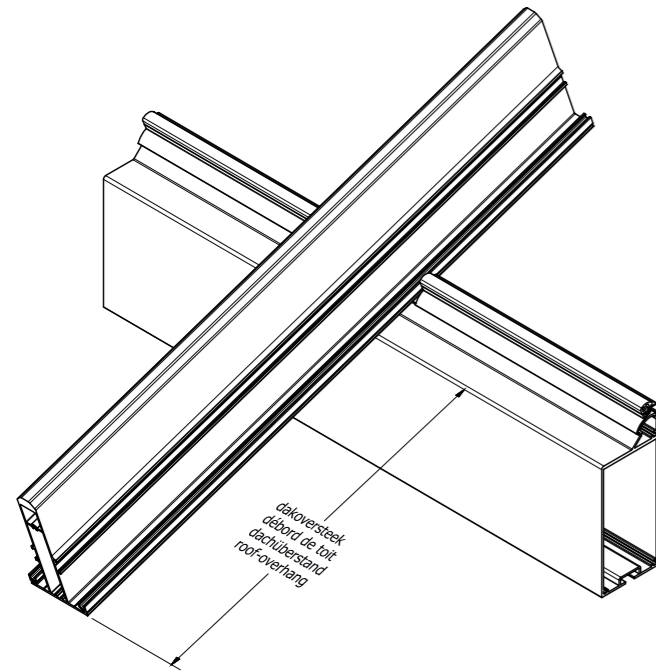

GLASOVERSTEEK

GLASOVERSTEEK - VARIABLE GOOT  
 DÉBORD DE TOIT - GOUTTIÈRE VARIABLE  
 DACHÜBERSTAND - VARIABLE RINNE  
 ROOF OVERSTAND - VARIABLE GUTTER

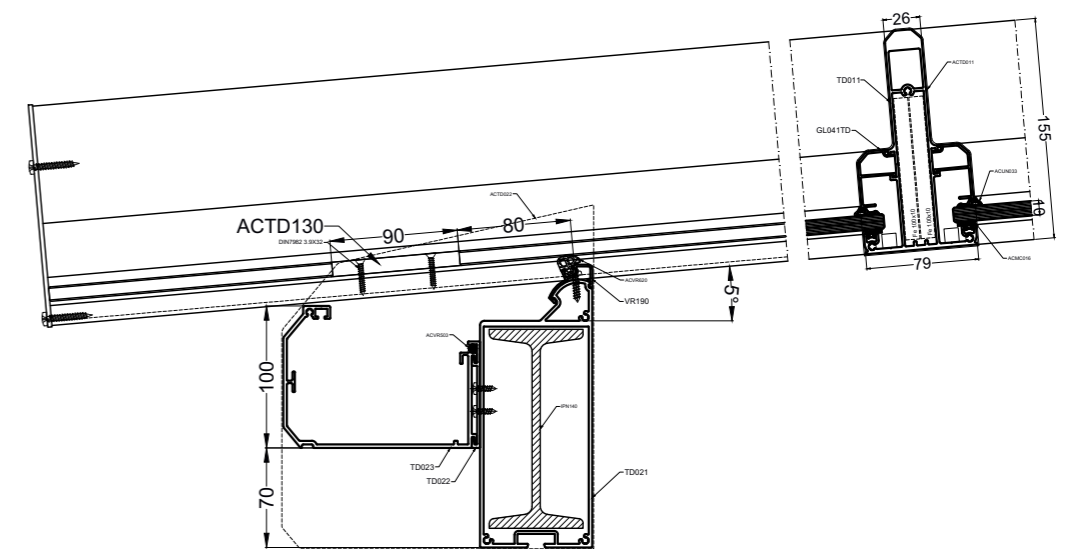
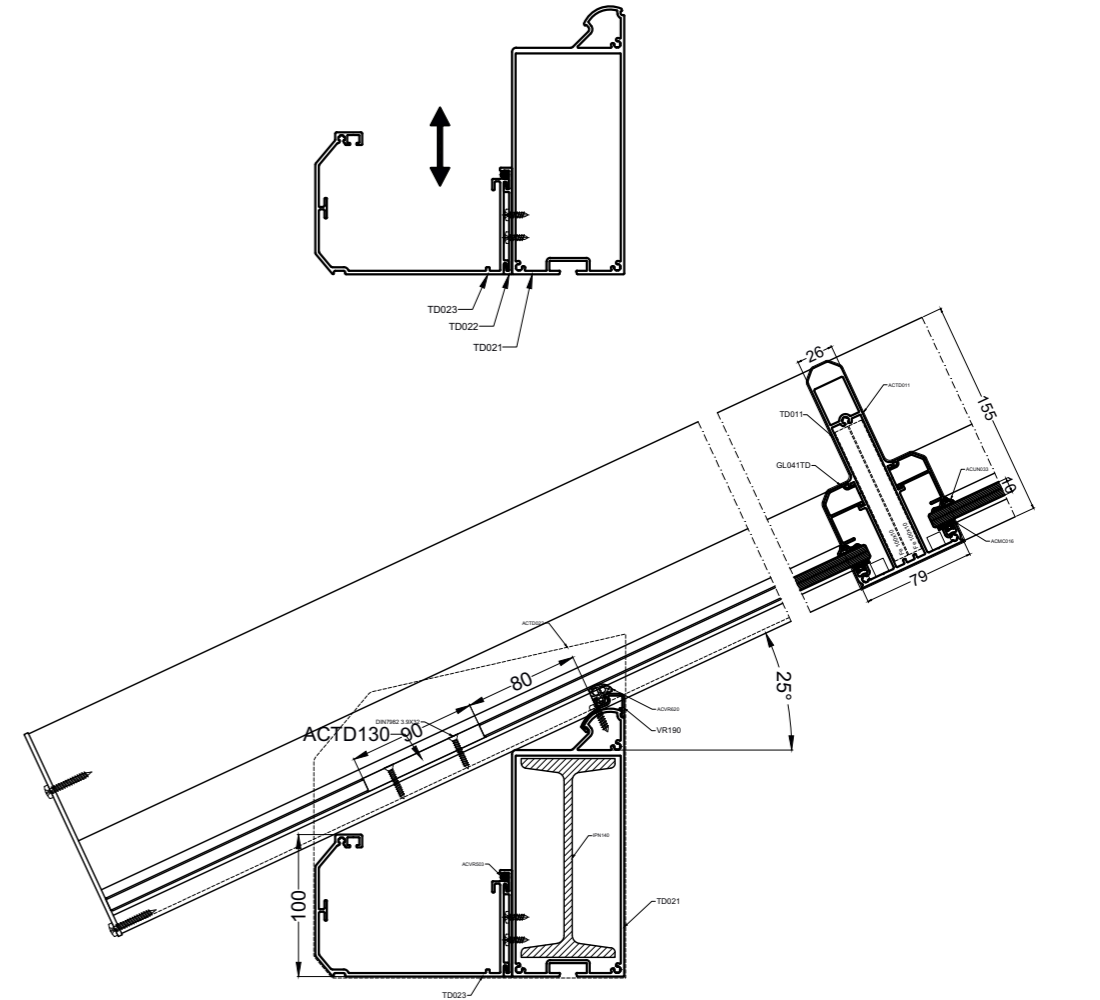
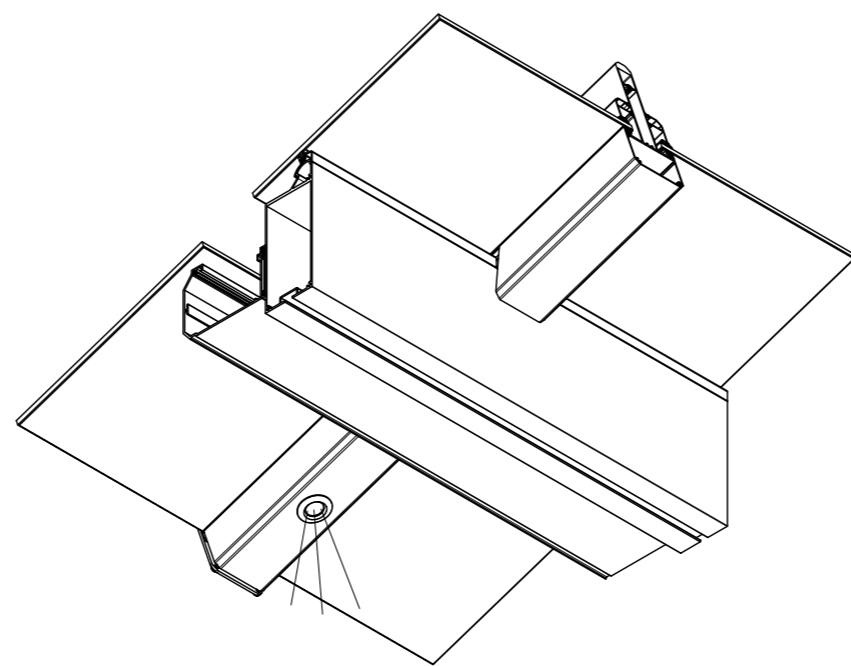
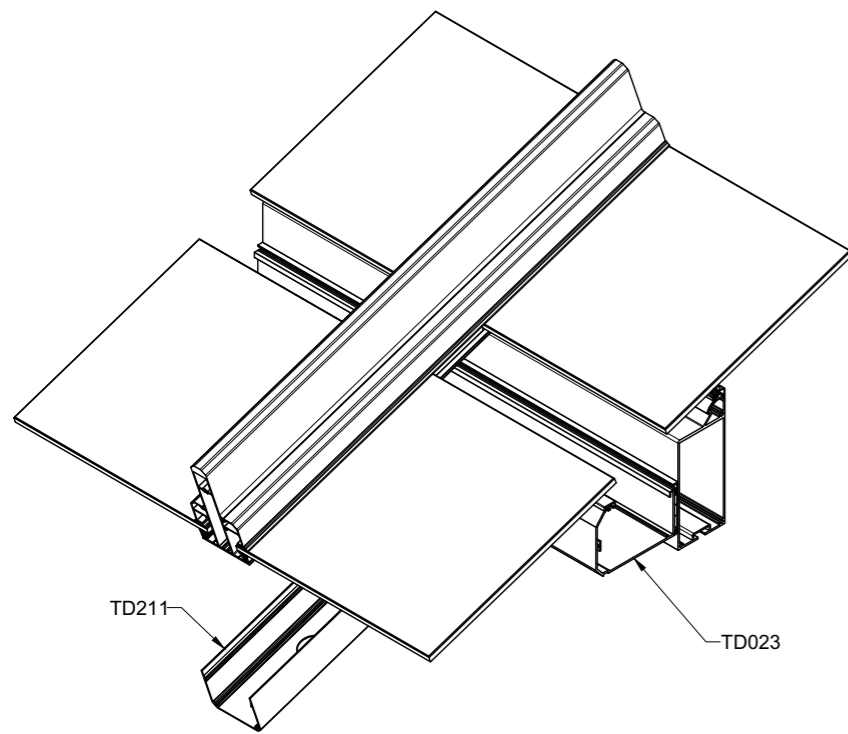
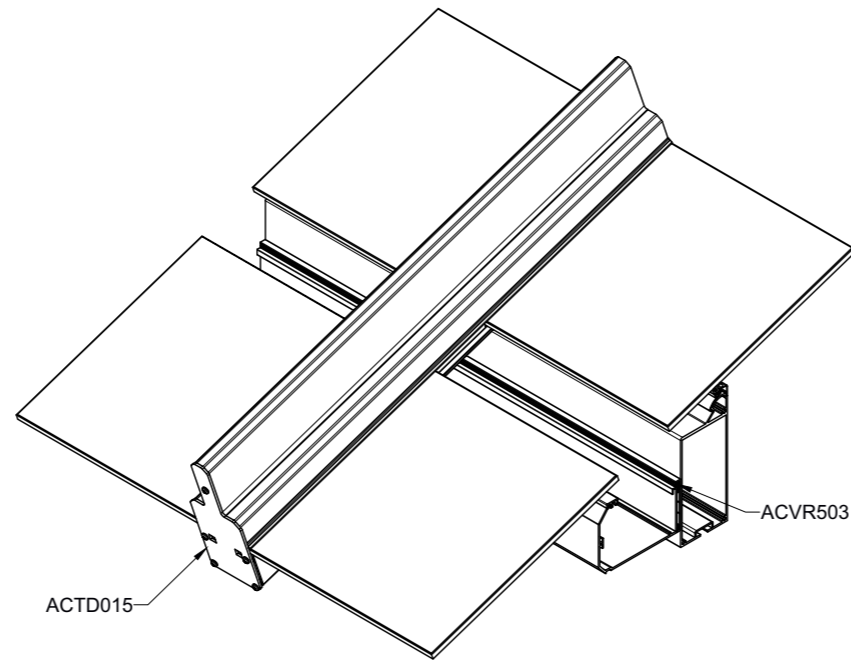
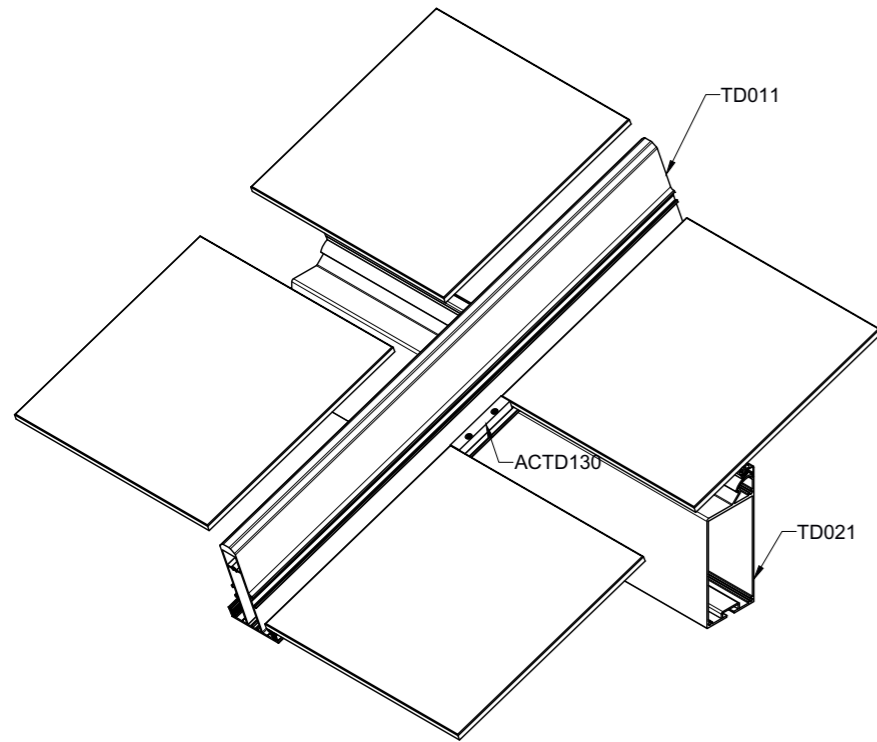

DEMONTAGE VAN DE KABELGOTEN  
DÉMONTAGE DES PROFILS DE RECOUVREMENT  
DEMONTAGE DES KABELKANALS  
DISASSEMBLING THE WIREWAY PROFILES

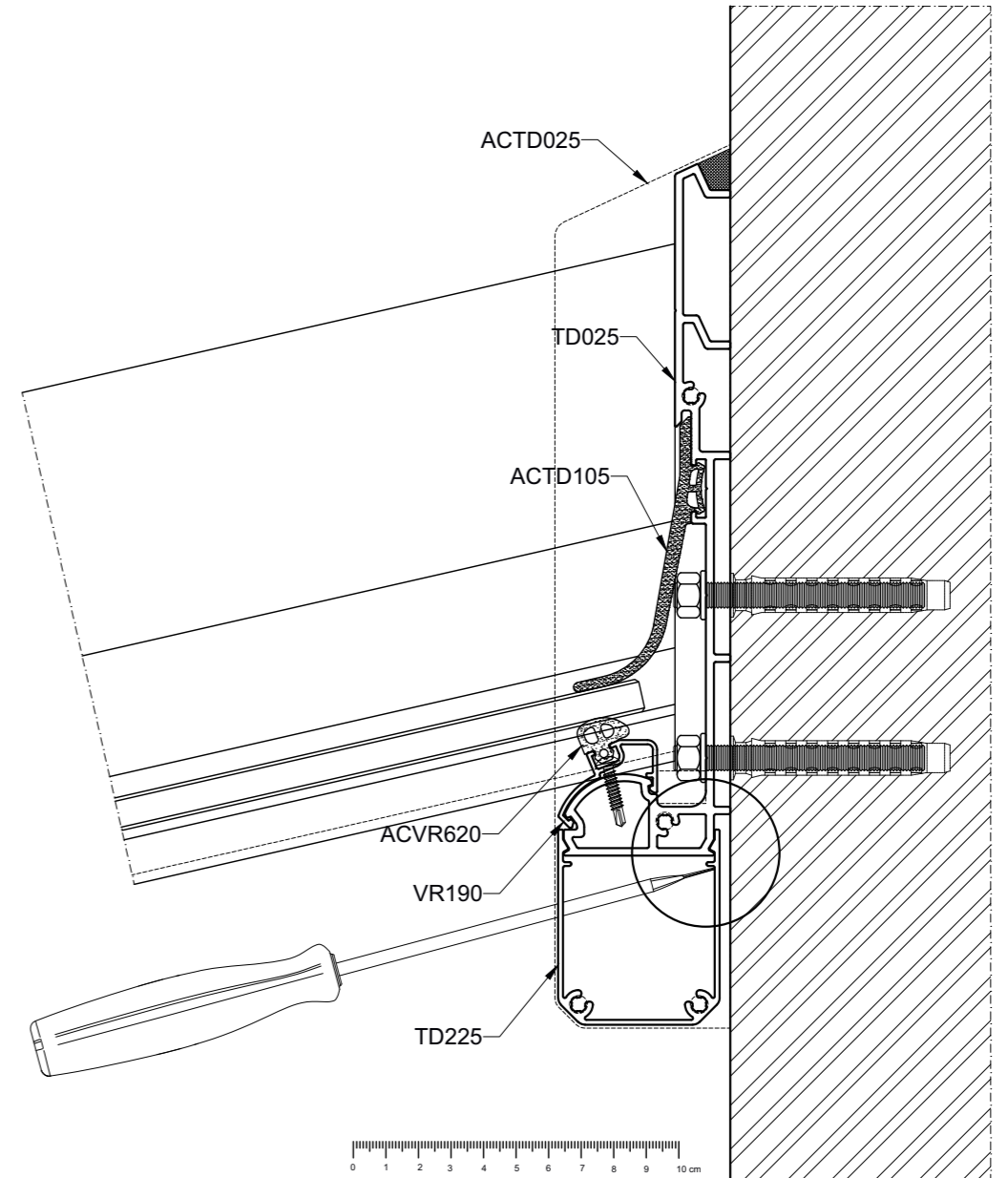
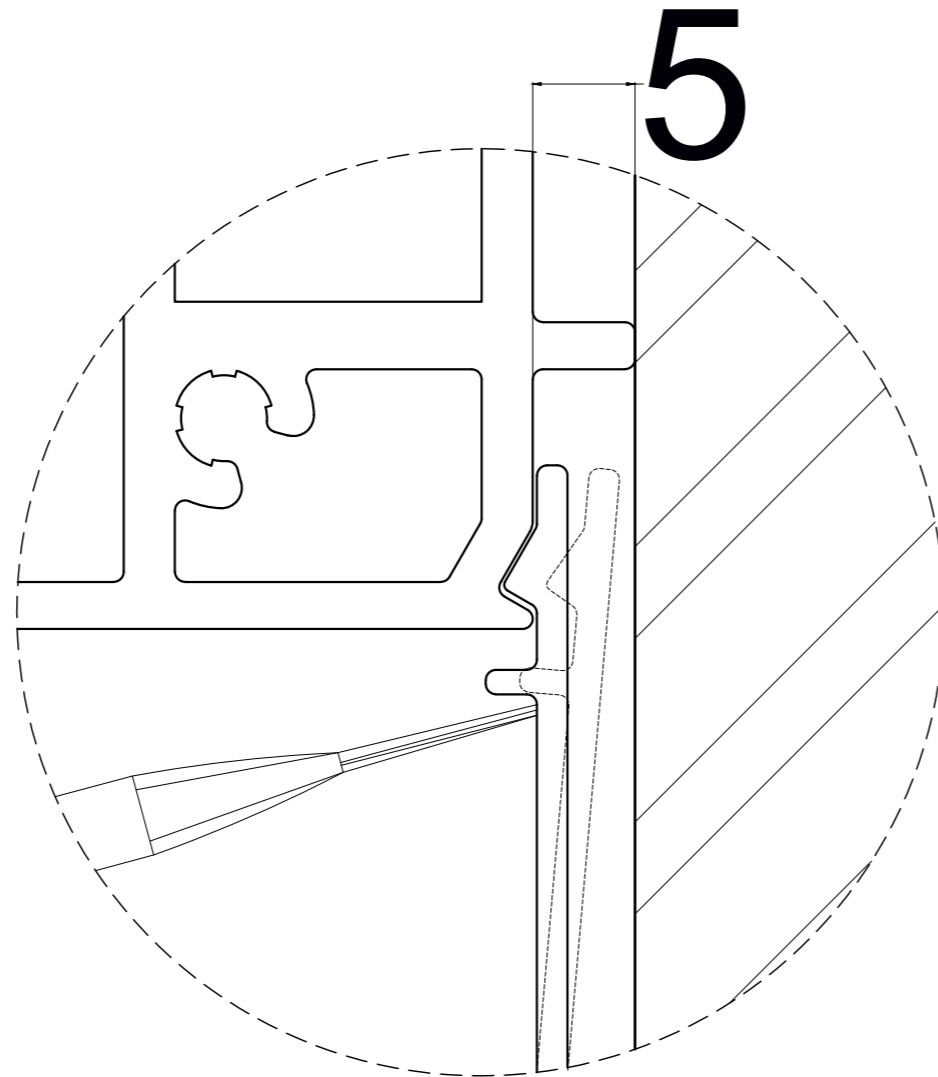
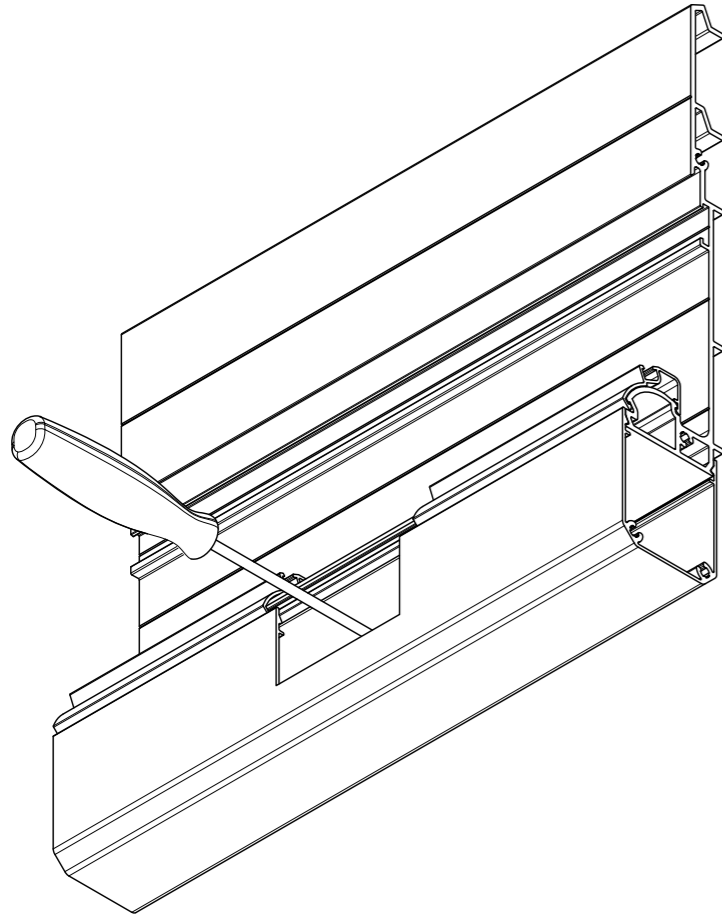



LENGTE VAN TD211  
LONGUEUR TD211  
LÄNGE VON TD211  
LENGTH OF TD211

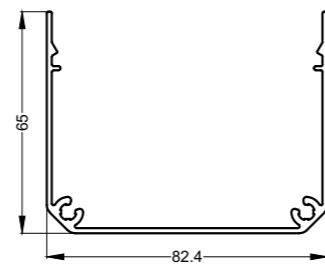
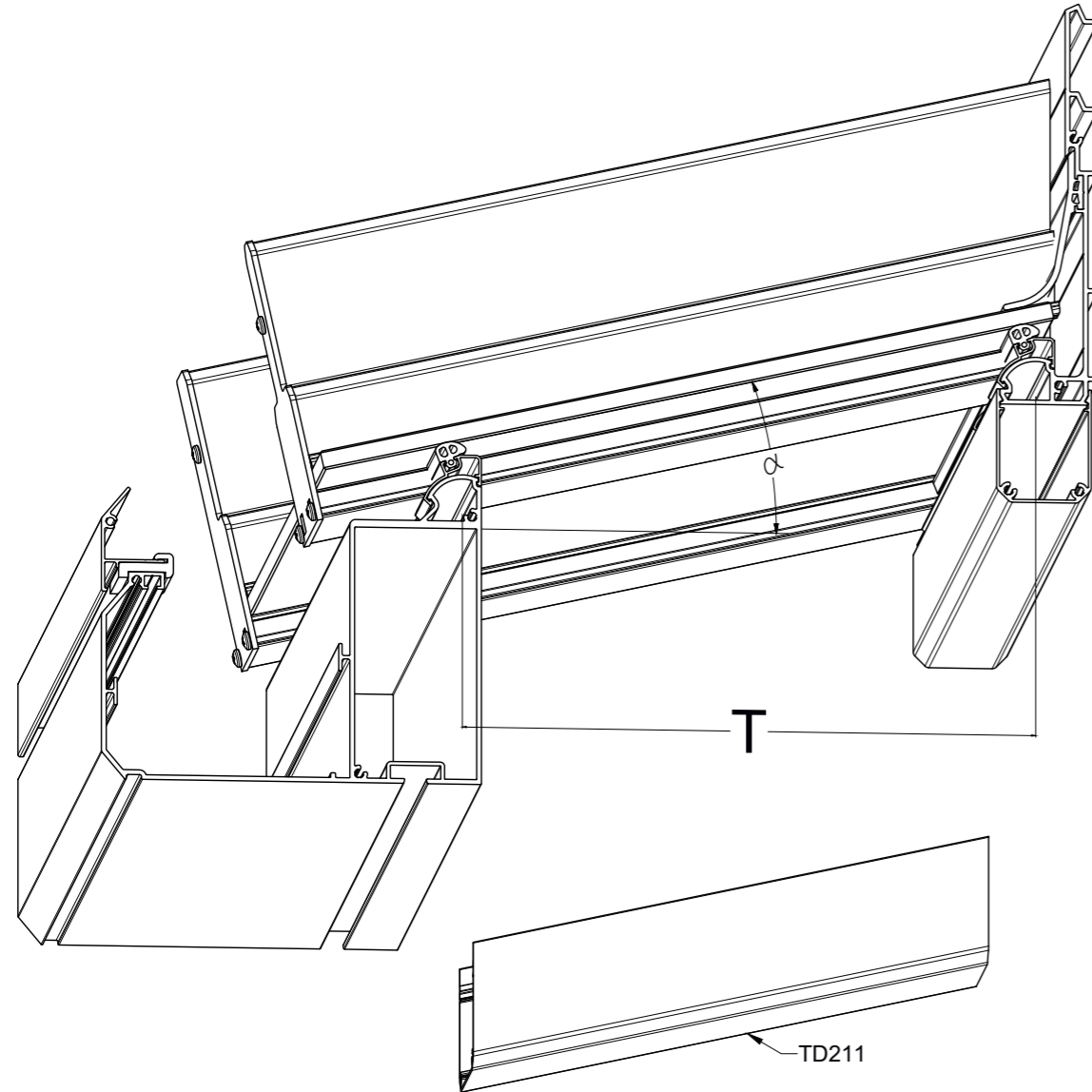

TD211

$$(31 * (\tan \alpha)) + ((T - 30.4) / (\cos \alpha)) + ((34 * (\tan \alpha))$$

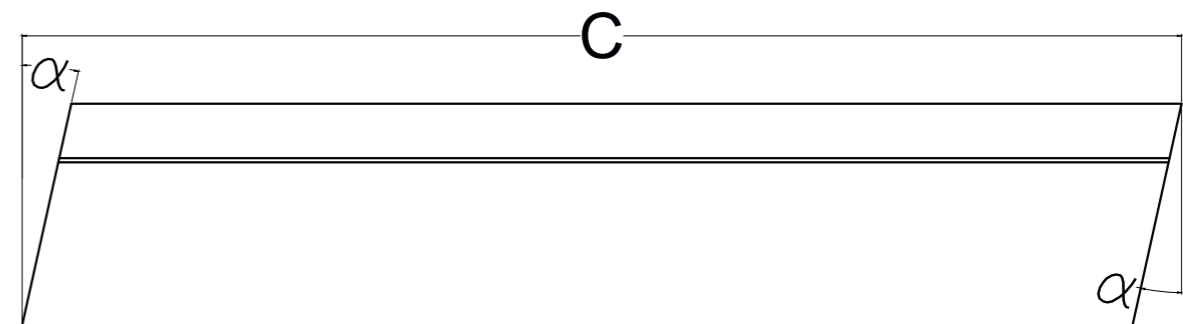

# TD Terrassendach

AFWERKING TUSSEN ONDERBOUW EN MUUR (25mm)  
 FINITION ENTRE ELEMENT SOUS TERRASSENDACH ET MUR (25mm)  
 VERARBEITUNG ZWISCHEN WINDSCHUTZ UND WAND (25mm)  
 FINISHING BETWEEN SIDE ELEMENT AND WALL (25mm)

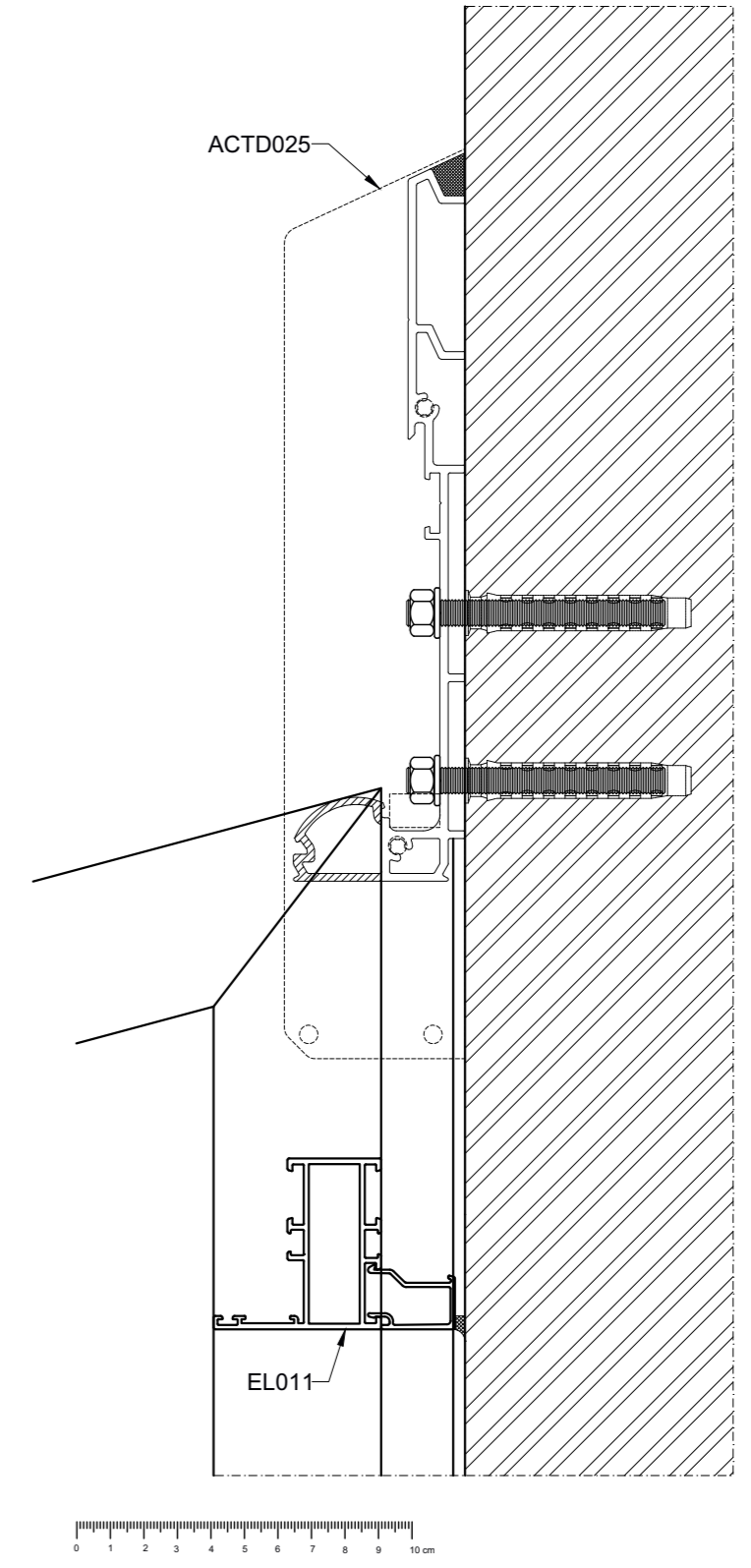
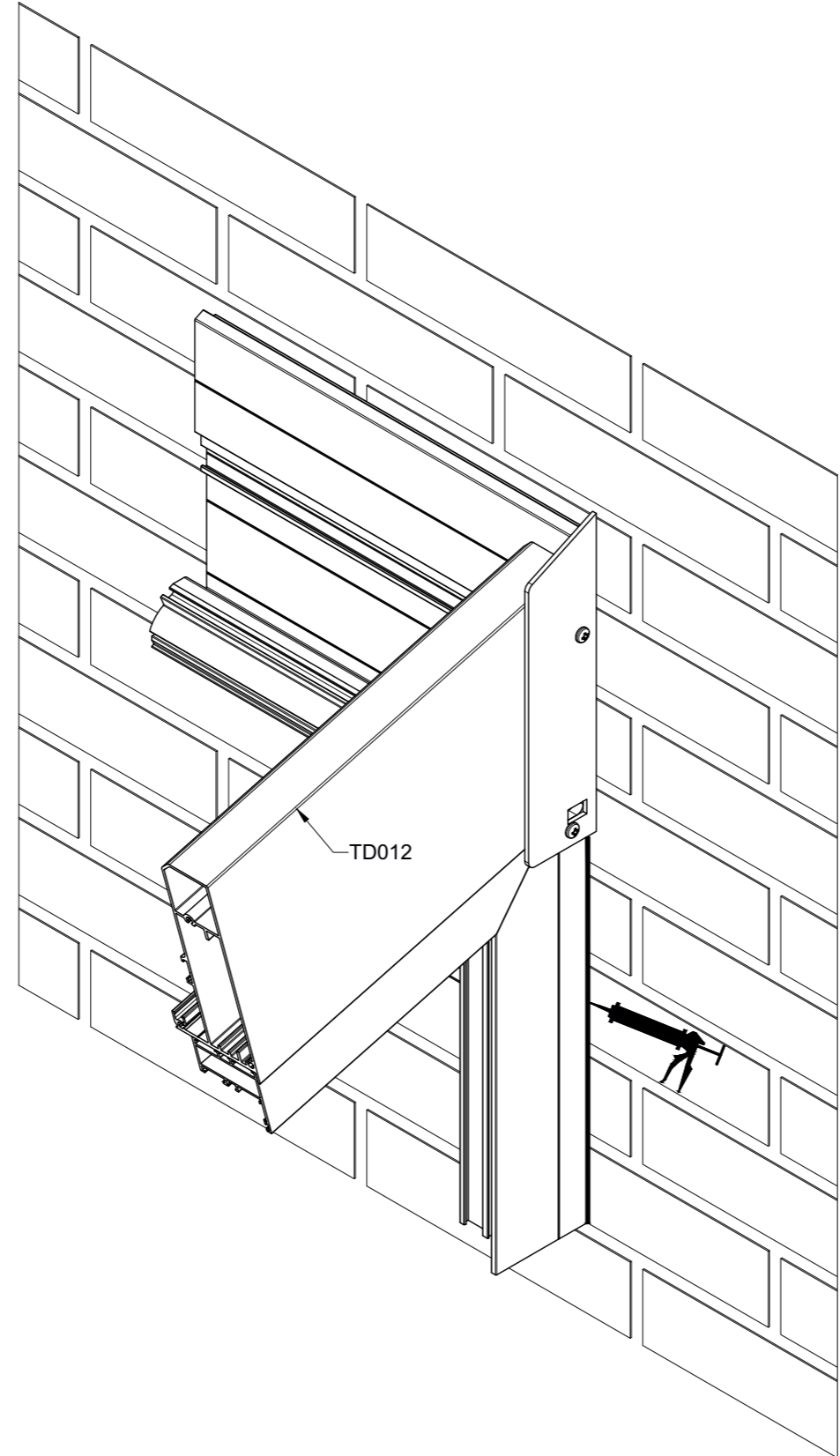
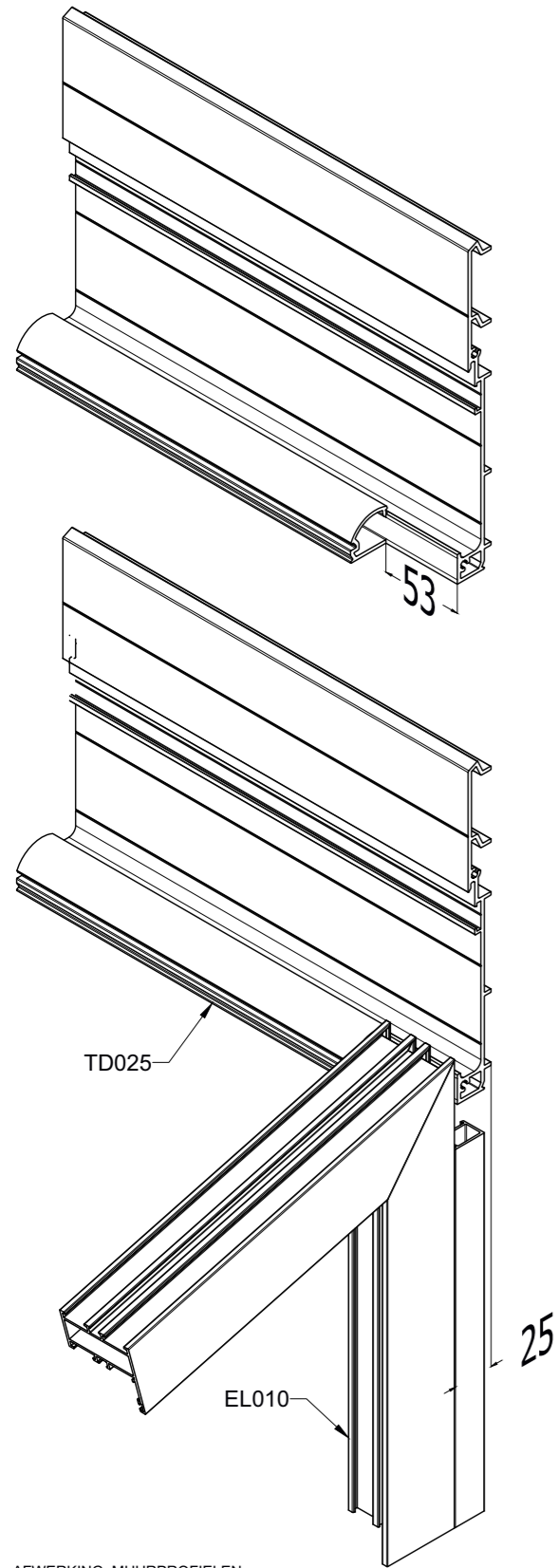

AFWERKING\_MUURPROFIELEN

AFWERKING TUSSEN ONDERBOUW EN MUUR (50mm)  
 FINITION ENTRE ELEMENT SOUS TERRASSENDACH ET MUR (50mm)  
 VERARBEITUNG ZWISCHEN WINDSCHUTZ UND WAND (50mm)  
 FINISHING BETWEEN SIDE ELEMENT AND WALL (50mm)

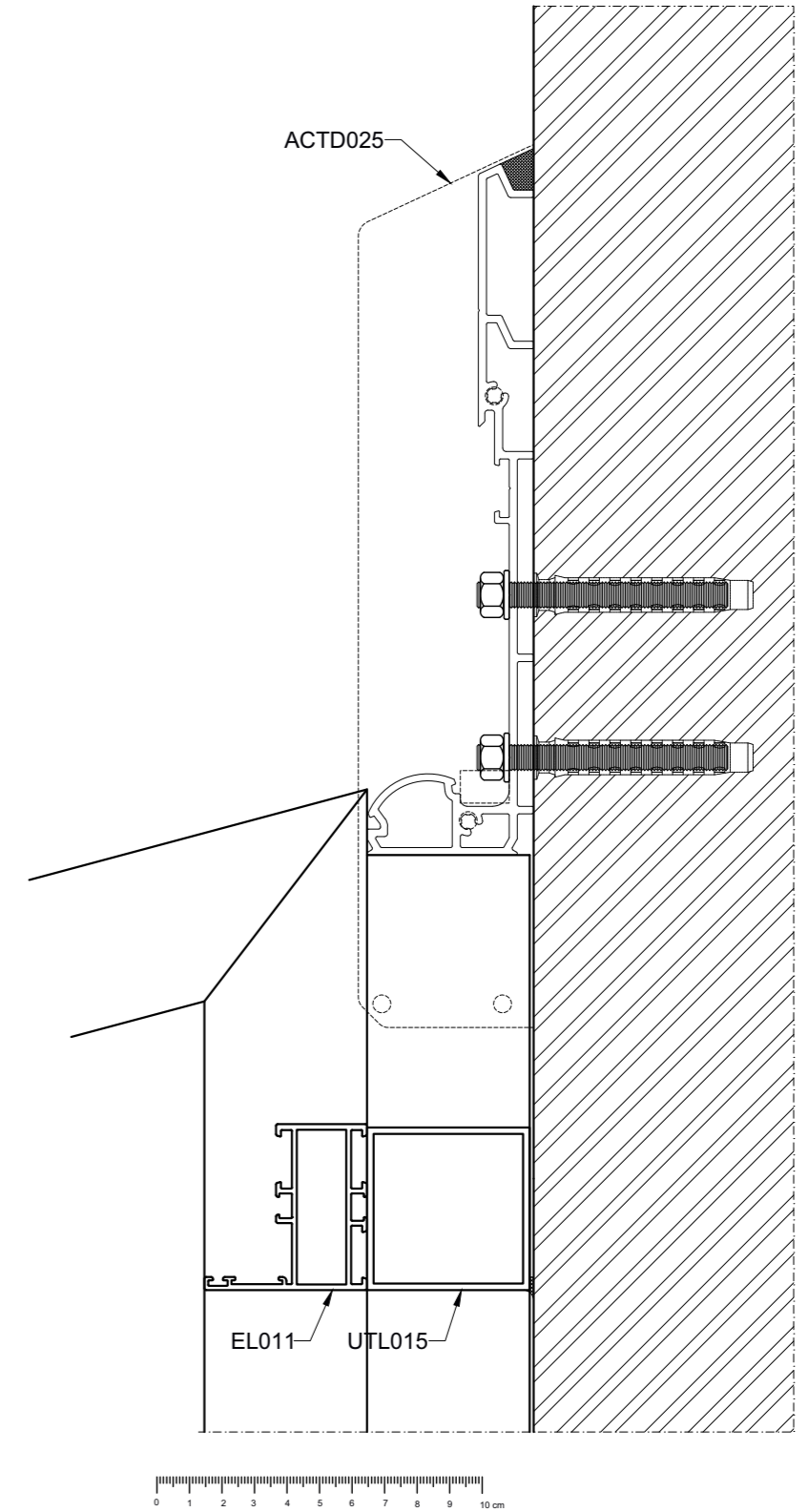
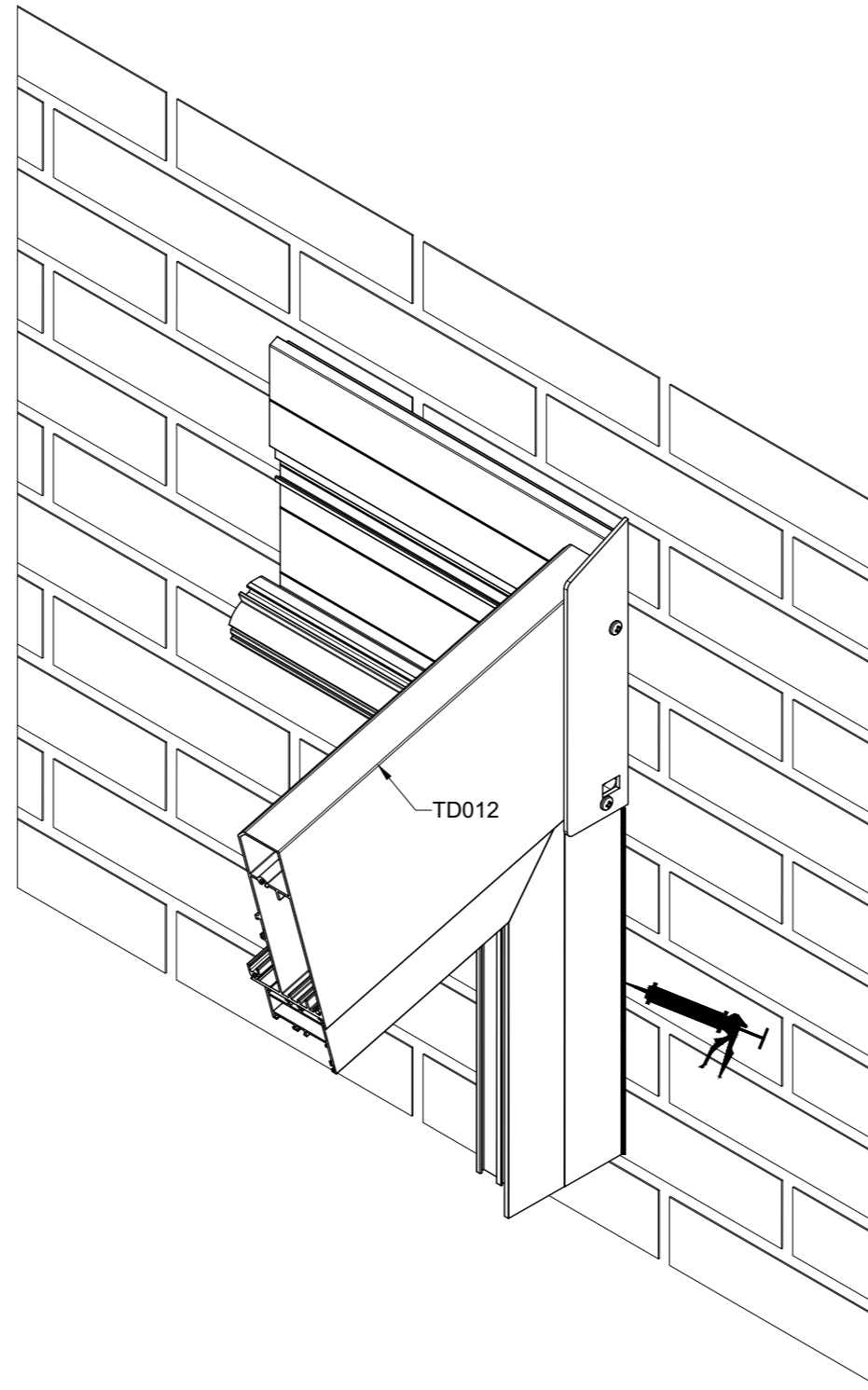
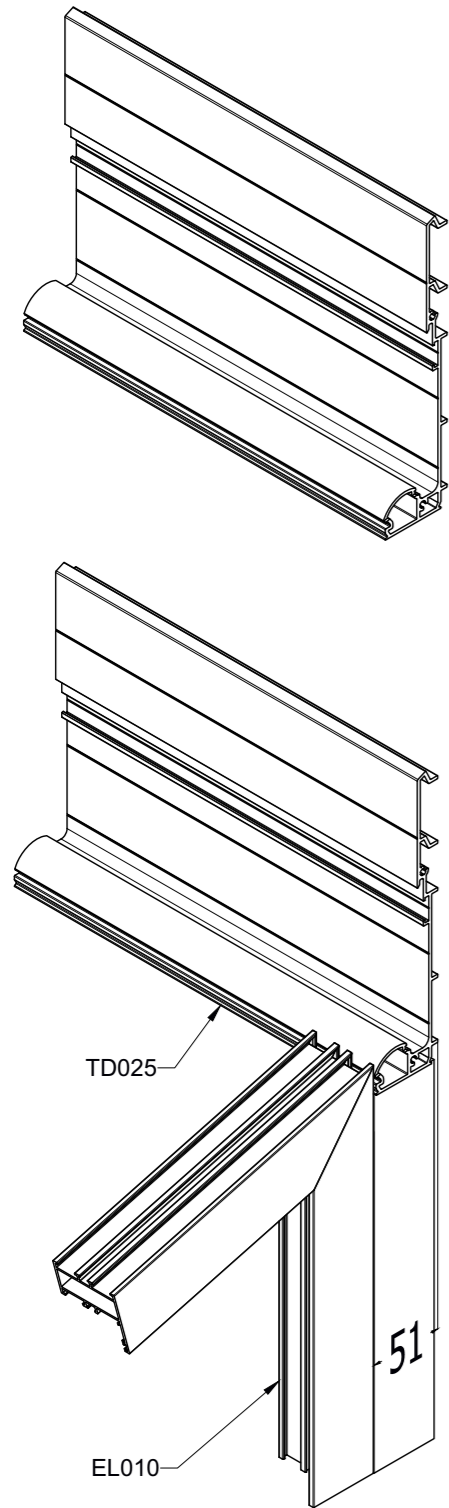

AFWERKING\_MUURPROFIELEN\_2



# TD Terrassendach

INKEPING VOOR ZIJLIGGER  
ENTAILLE POUR CHEVRON LATERAL  
AUSKLINKUNG FÜR RANDSPARREN  
NOTCH FOR SIDE RAFTER

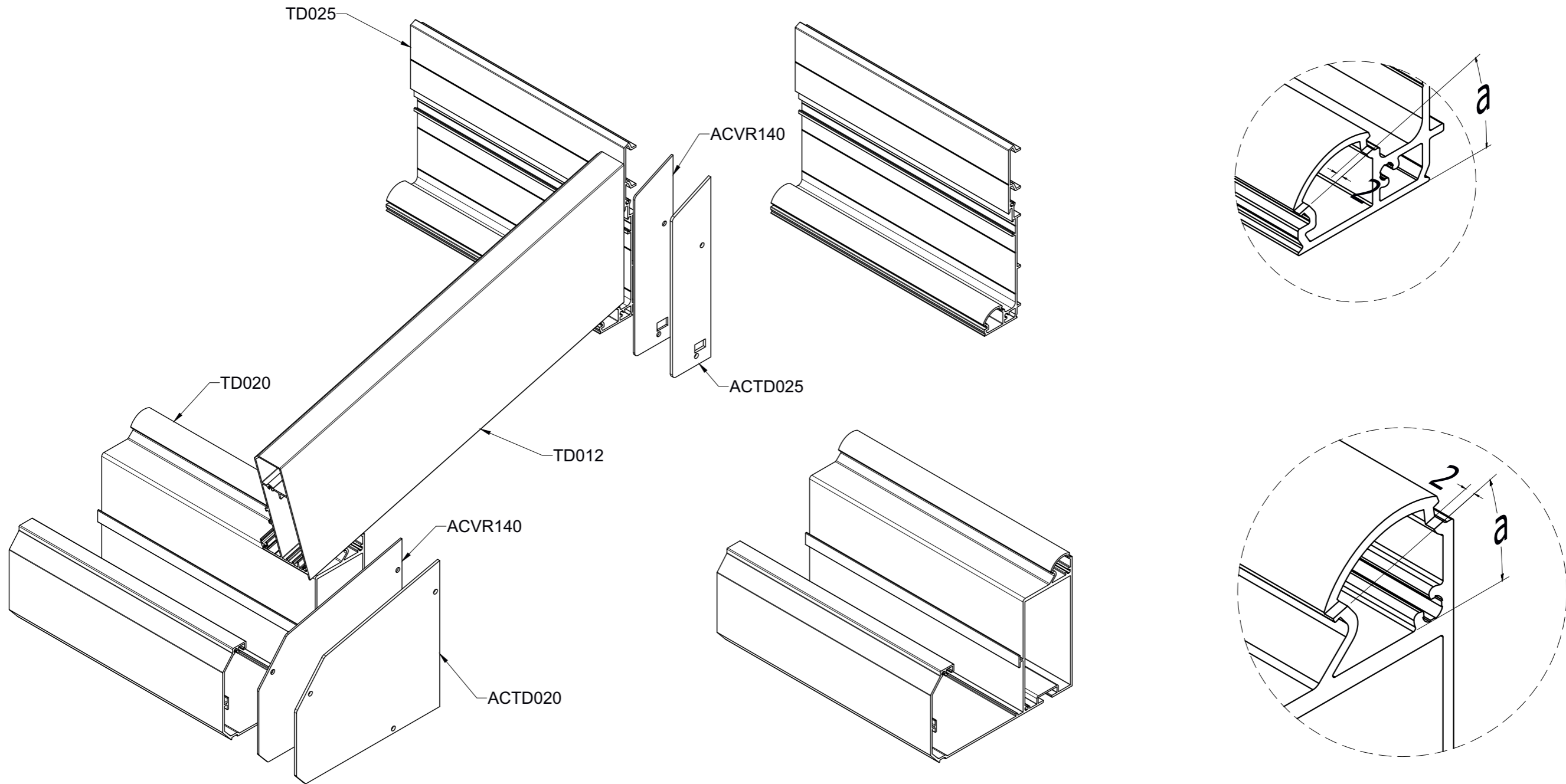

AUSKLINKUNG\_RANDSPARREN

MAATBEPALING HOOGTE TRAPEZIUM  
 CALCULATION DES DIMENSIONS HAUTEUR TRAPEZE  
 MASSBESTIMMUNG HOHE TRAPEZ  
 HEIGHT CALCULATION TRAPEZIUM

H	$HM - (HG + 144) + 5$
T	$D - (167 + 32.5)$
$\alpha$	$\text{ARCTAN}(H/T)$
A	$((T - 2.5) / (\cos \alpha))$
X1	$((20 / (\cos \alpha)) + ((10 * (\tan \alpha)) + 144)$
X2	$((20 / (\cos \alpha)) + ((7.5 * (\tan \alpha)) + 5)$

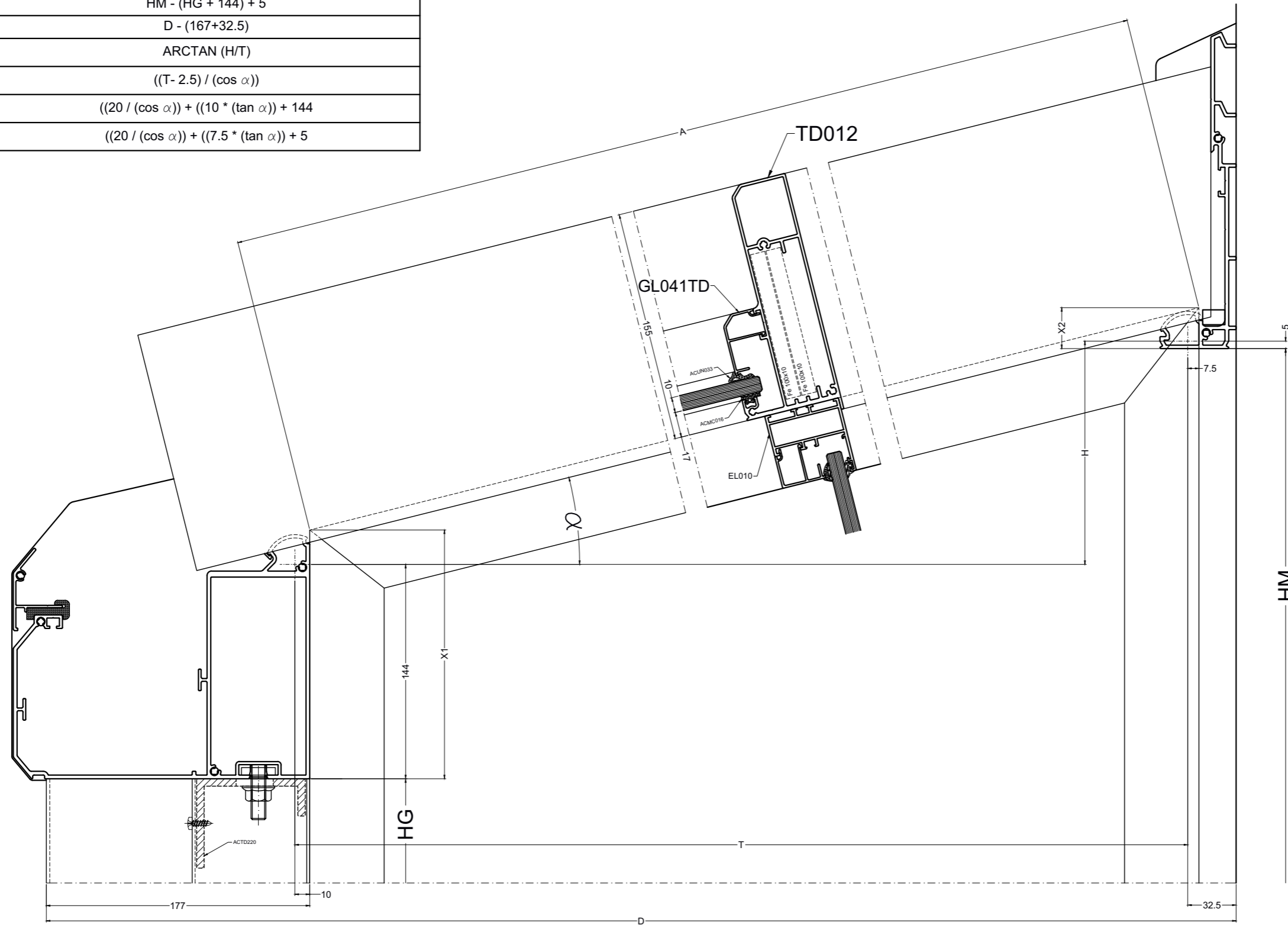

BEREKENING HOEK NOORDBOOM  
 CALCULATION ANGLE ARRETIER  
 BERECHNUNG WINKEL GRATSPARREN  
 ANGLE CALCULATION HIP-RAFTER

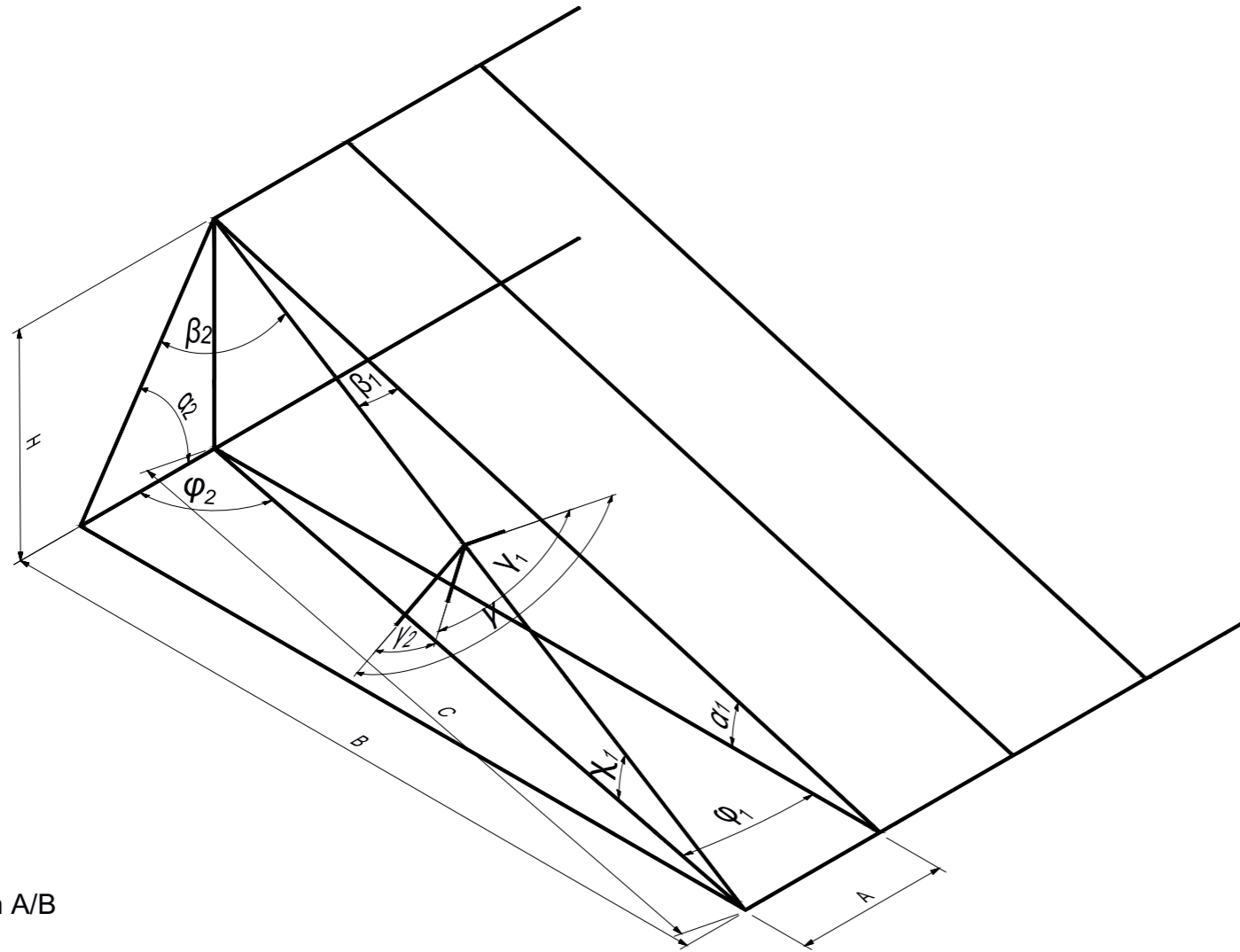

$$\varphi_1 = \arctan A/B$$

$$\gamma_1 = \arccos (\sin\varphi_1 \times \sin\alpha_1)$$

$$\varphi_2 = \arctan B/A$$

$$\gamma_2 = \arccos (\sin\varphi_2 \times \sin\alpha_2)$$

$$\beta_1 = \arctan (\tan\varphi_1 \times \cos\alpha_1)$$

$$\beta_2 = \arctan (\tan\varphi_2 \times \cos\alpha_2)$$

$$\chi_1 = \arctan H/C$$

$$\gamma = \gamma_1 + \gamma_2$$

Voorbeeld - exemple - Beispiel - example

A = 1000     $\alpha_1 = 15^\circ$   
 B = 3000     $\alpha_2 = 38.8^\circ$

- ①  $\varphi_1 = \arctan \frac{1000}{3000} = 18.4^\circ$   
 $\gamma_1 = \arccos (\sin 18.4^\circ \times \sin 15^\circ) = 85.3^\circ$
- ②  $\varphi_2 = \arctan \frac{3000}{1000} = 71.6^\circ$   
 $\gamma_2 = \arccos (\sin 71.6^\circ \times \sin 38.8^\circ) = 53.5^\circ$
- ③  $\gamma = 85.3^\circ + 53.5^\circ = 138.8^\circ$

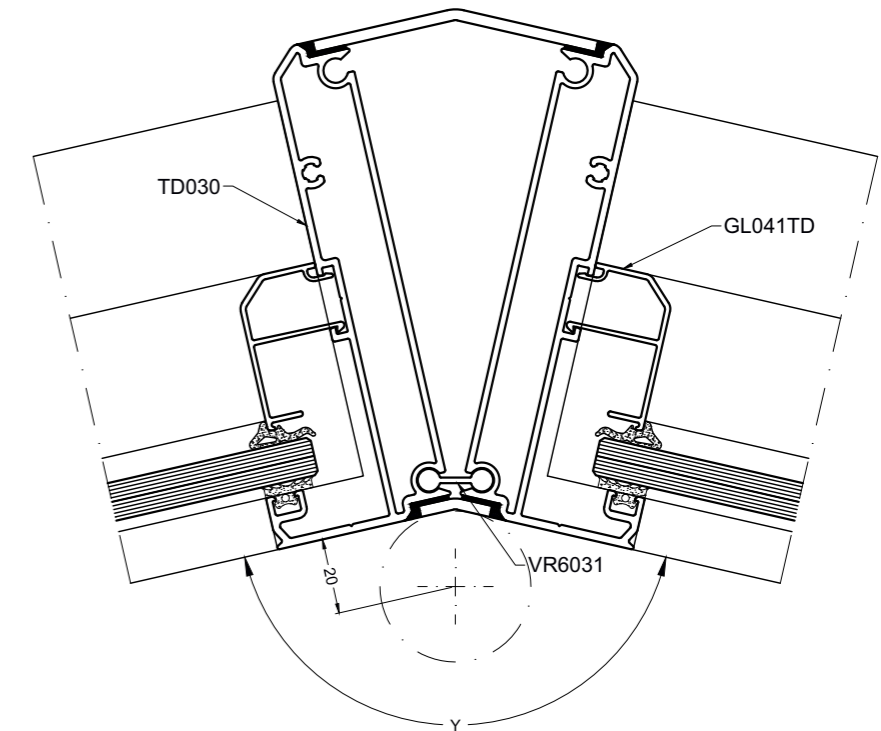

BEREKENING HOEK TD111 (AANSLUITING NOORDBOOM)  
 CALCULATION ANGLE TD111 (MONTAGE EMPANNON)  
 BERECHNUNG WINKEL TD111 (ANSCHLUSS GRATSPARREN)  
 ANGLE CALCULATION TD111 (CONNECTION HIP-RAFTER)

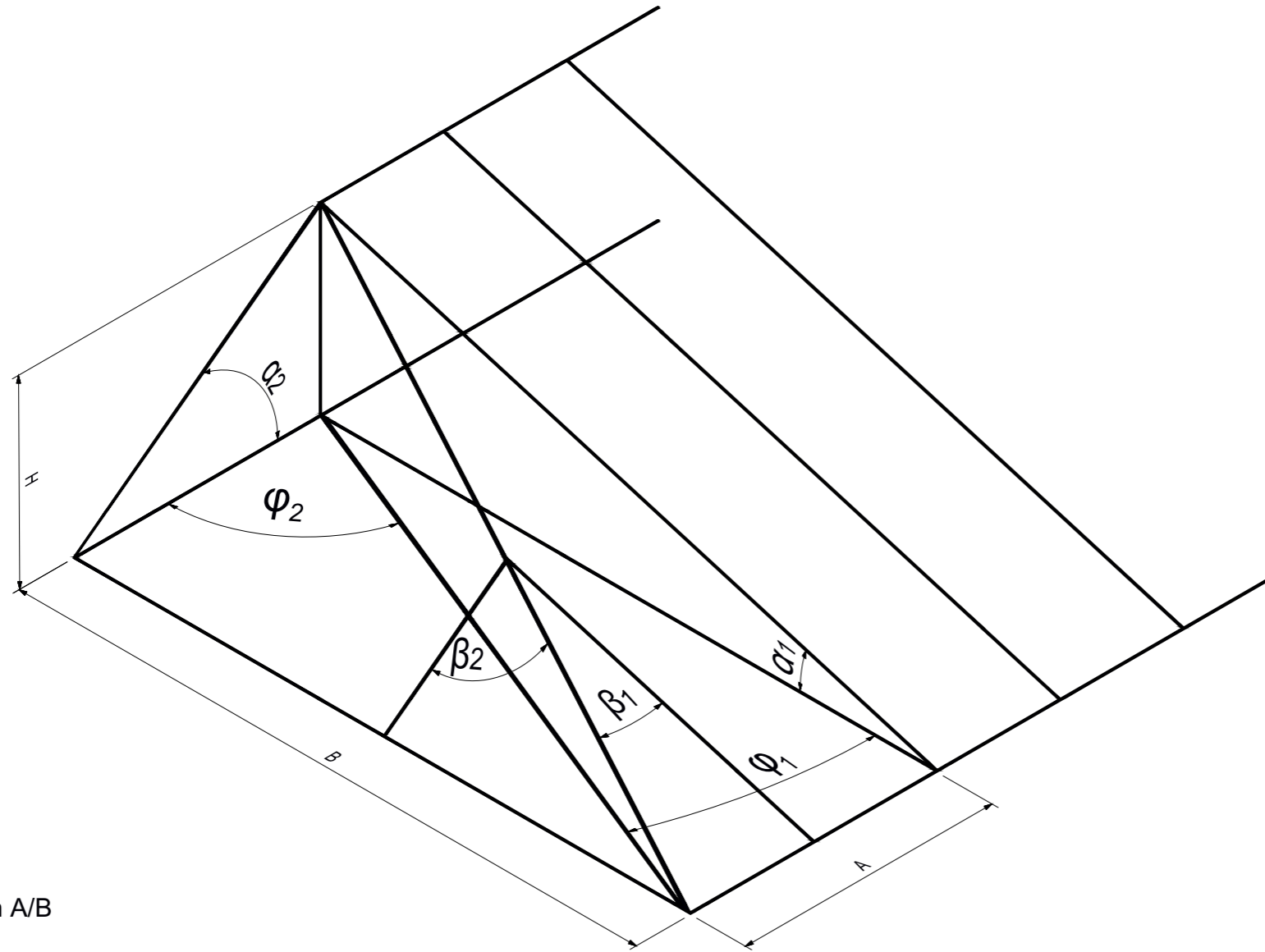

$$\varphi_1 = \arctan A/B$$

$$\gamma_1 = \arccos (\sin\varphi_1 \times \sin\alpha_1)$$

$$\varphi_2 = \arctan B/A$$

$$\gamma_2 = \arccos (\sin\varphi_2 \times \sin\alpha_2)$$

$$\beta_1 = \arctan (\tan\varphi_1 \times \cos\alpha_1)$$

$$\beta_2 = \arctan (\tan\varphi_2 \times \cos\alpha_2)$$

$$\gamma = \gamma_1 + \gamma_2$$

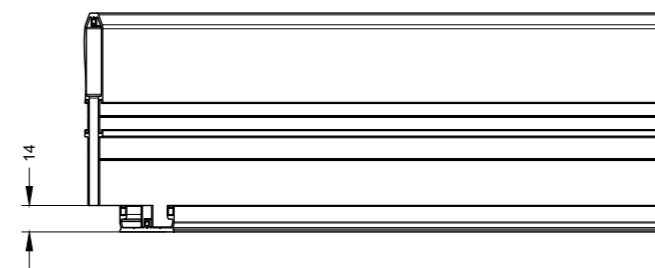
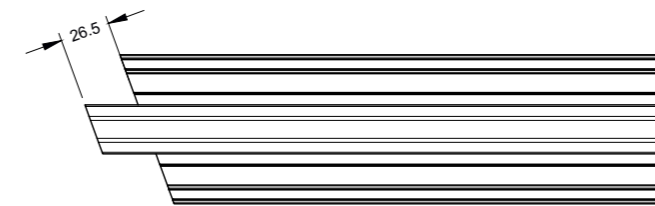
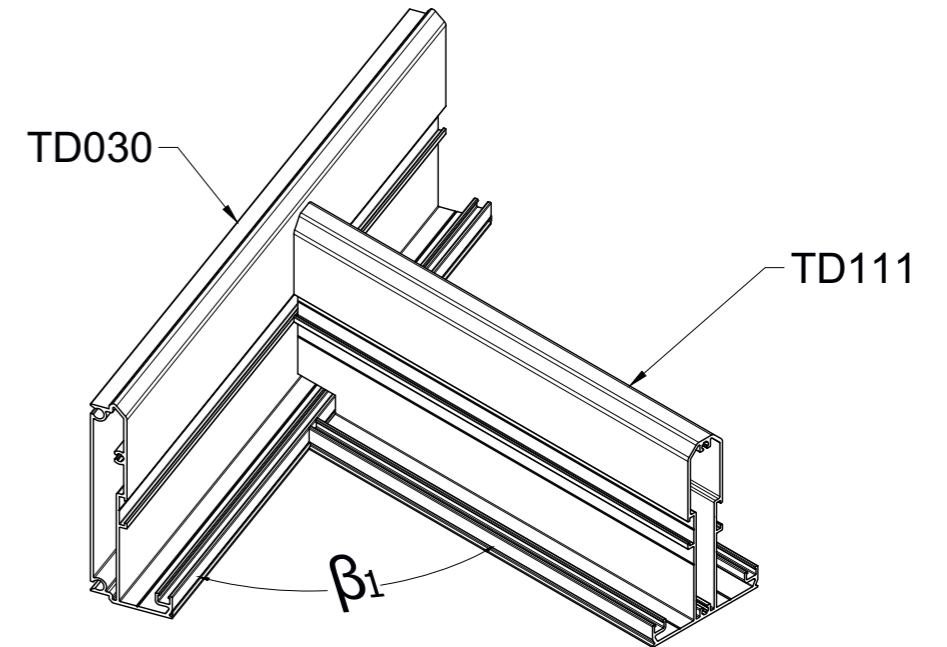

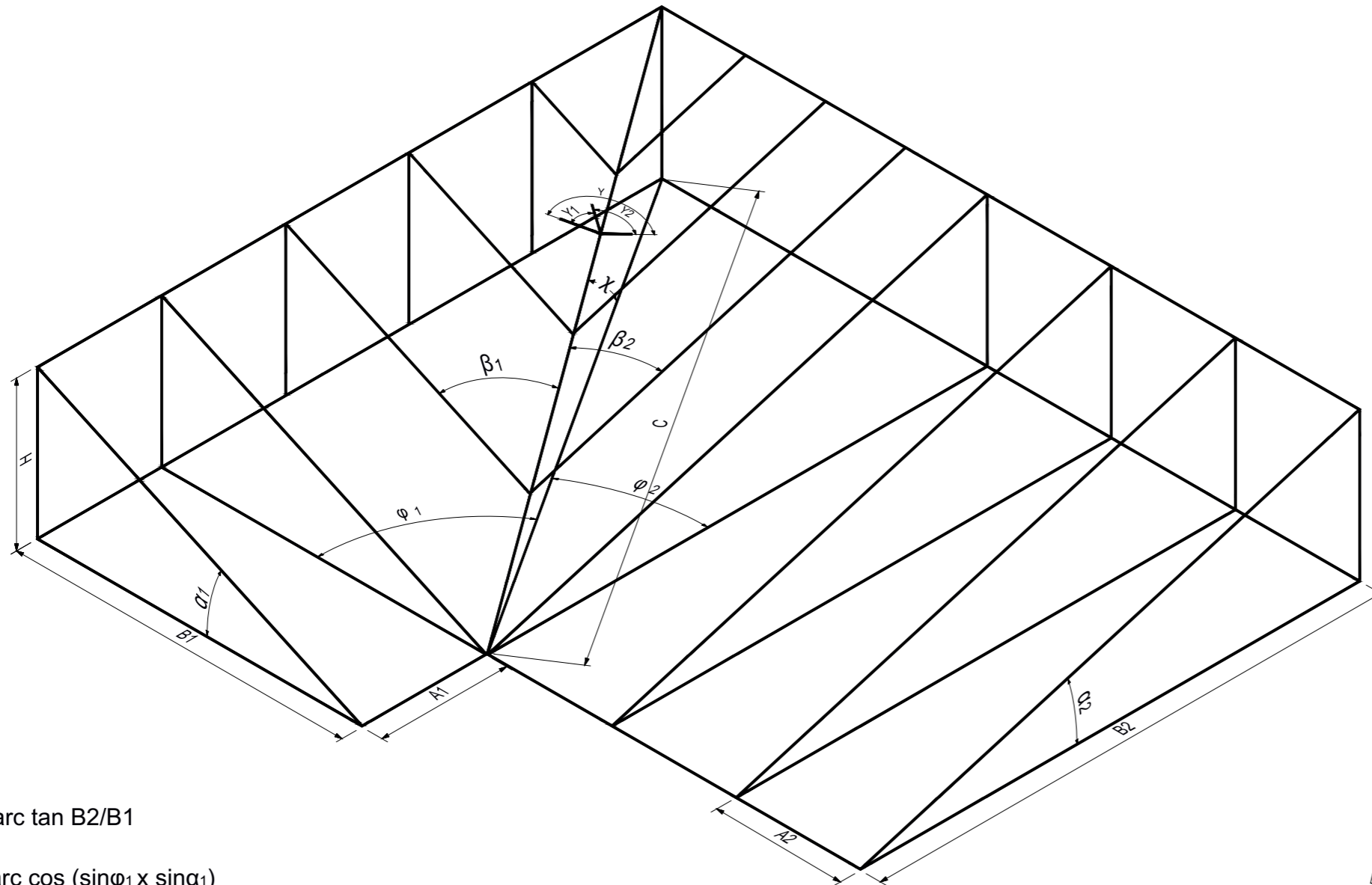

$$\varphi_1 = \arctan B2/B1$$

$$\gamma_1 = \arccos (\sin\varphi_1 \times \sin\alpha_1)$$

$$\varphi_2 = \arctan B1/B2$$

$$\gamma_2 = \arccos (\sin\varphi_2 \times \sin\alpha_2)$$

$$\beta_1 = \arctan (\tan\varphi_1 \times \cos\alpha_1)$$

$$\beta_2 = \arctan (\tan\varphi_2 \times \cos\alpha_2)$$

$$\chi_1 = \arctan H/C$$

$$\gamma = \gamma_1 + \gamma_2$$

