

vision

RAMEN
FENETRES
FENSTER
WINDOWS

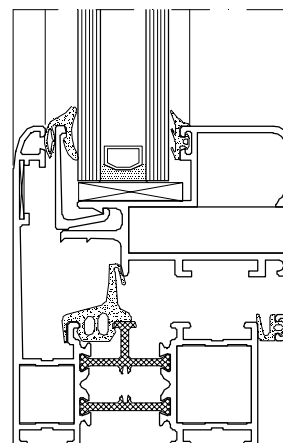

VNa

PROFIELEN _____ P. 9

PROFILS
PROFILE
PROFILES

VNb

TOEBEHOREN _____ P. 15

ACCESSOIRES
ZUBEHORTEILE
ACCESSORIES

VNc

DOORSNEDEN _____ P. 31

COUPES
SCHNITT
SECTIONS

VNd

ZAAGTABELLEN _____ P. 69

TABLES DE SCIAGES
ZUSCHNITT-TABELLEN
SAWING TABLES

VNe

WERKTEKENINGEN _____ P. 73

DESSINS DE CONSTRUCTION
KONSTRUKTIONZEICHNUNGEN
CONSTRUCTION DRAWINGS

AFKORTINGEN / ABBREVIATIONS / ABKURZUNGEN / ABBREVIATIONS

BR = BRUT - BRUT - ROH - BRUT

AN = GEANODISEERD - ANODISE - ELOXIERT - ANODISED

AN (■) = GELAKT - LAQUE - LACKIERT - LACQUERED -- RAL9006M

KL = STANDAARDKLEUREN - COULEURS STANDARDS - BASIS FARBEN - BASIC COLORS

GS = SPECIAAL GEMOFFELD - LAQUE SPECIAL - SPECIALFARBE - SPECIAL COLOR

Z = ZWART - NOIR - SCHWARZ - BLACK

W = WIT - BLANC - WEISS - WHITE

De tekeningen die voorgesteld zijn op schaal 1:1, kunnen kleine maatafwijkingen vertonen, te wijten aan de reproductietechniek van deze catalogoog.

Les dessins représentés à l'échelle 1 peuvent avoir de légères variations dimensionnelles dues aux techniques de reproduction de ce catalogue.

Die Zeichnungen im Maßstab 1:1 können aus technischen Reproduktionsgründen leichte Messungsschwankungen darstellen.

The drawings represented on a scale 1 basis may have light dimensional variations due to the reproduction of the manual.

BUITENKADER _____	P. 9
PROFIL D'ENCADREMENT KADERPROFILE OUTER FRAME	
VLEUGELPROFIELEN _____	P. 10
OUVRANTS FLUGELPROFILE VENT PROFILES	
THERMISCH VLEUGELPROFIEL _____	P. 11
OUVRANT THERMIQUE THERMISCH FLUGELPROFIL THERMIC WINDOW PROFILE	
TUSSENREGELS _____	P. 12
TRAVERS SPROSSENPROFILE TRANSOMS	
GLASLATTEN EN SLUITLATTEN _____	P. 13
LATTES A VITRAGE ET TRINGLES GLASLEISTE UND SCHUBSTANGE GLAZING BEADS AND LINKBARS	

RAMEN P. 31FENETRES
RAHMEN
WINDOWS





GLASTABELLEN P. 62TABLES DE VITRAGE
BEGLAZUNG TABELLEN
GLAZING TABLES

RAMEN _____ P. 69

FENETRES
RAHMEN
WINDOWS

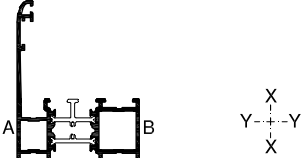
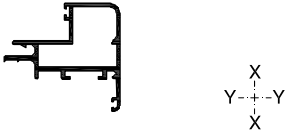
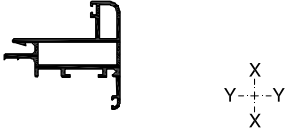
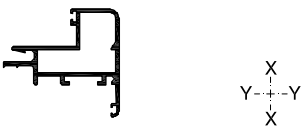

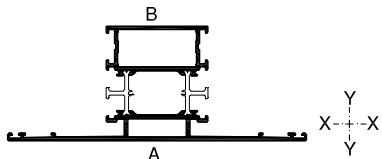
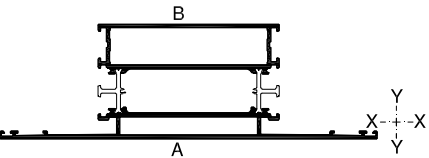



MONTAGE VN010 - VN032 _____ P. 73
MONTAGE VN010 - VN032
ZUSAMMENBAU VN 010 - VN032
ASSEMBLY VN010 - VN032

UITSPARING VN162 _____ P. 74
ENTAILLE VN162
EINBAU VN162
MACHINING VN162

NUMMER NUMERO NUMBER	AFBEELDING IMAGE BILD PICTURE	BLAD PAGE SEITE PAGE	OMTREK PERIM. UMRIB PERIM. mm	MECH. MEC. MECH. MEC. mm	lx (cm4)		ly (cm4)		LENGTE LONG. LANGE LENGTH	VERP. PER EMB. PAR PACK PR.	BR	AN	KL	GS	M1
					Wx (cm3)	Wy (cm3)	Wx (cm3)	Wy (cm3)							
VN010		9	491	134	29.40	26.68	7.37	4.59	6,5	2	X	X	X	X	X
VN020		10	326,1	88	14.81	8.36	3.88	2.6	6,5	2	X	X	X	X	
VN022		10	327	74	15.49	6.81	3.90	2.2	6,5	2	X	X	X	X	
VN023		10	327,3	84	14.91	7.86	3.88	2.49	6,5	2	X	X	X	X	
VN024		10	327	84	15.19	7.64	3.88	2.41	6,5	2	X	X	X	X	
VN032		12	665.4	221	38.78	86.49	9.65	10.94	6,5	1	X	X	X	X	X
VN035		12	750,3	305	55.49	217.13	14.43	21.71	6,5	1	X	X	X	X	X
VN161		13	237,1	93	3.29	6.69	1.37	1.74	6,5	2	X	X	X	X	
VN162		13	87.1	30	-	-	-	-	6,5	6	X	X	X	X	

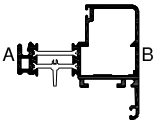
BR = BRUT - BRUT - ROH - BRUT
 AN = ANODISATIE - ANODISE - ELOXIERT - ANODISED
 KL = STANDAARDKLEUREN - COULEUR STANDARD - BASIS FARBEN - BASIC COLORS
 GS = GEMOFFELD SPECIAAL - LAQUE SPECIAL - SPECIALFARBE - SPECIAL COLOR
 M1 = BICOLOR - BICOLOR - BICOLOR - BICOLOR

A = BUITEN - EXTERIEUR - AUSSEN - OUTSIDE
 B = BINNEN - INTERIEUR - INNEN - INSIDE

NUMMER NUMERO NUMBER	AFBEELDING IMAGE BILD PICTURE	BLAD PAGE SEITE PAGE	OMTREK PERIM. UMRIB PERIM. mm	MECH. MEC. MECH. MEC. mm	Ix (cm4)	Iy (cm4)	LENGTE LONG. LANGE LENGTH	VERP. PER EMB. PAR PACK PR. PACK PR.	BR	AN	KL	GS	M1
					Wx (cm3)	Wy (cm3)							
VN164	 	13	205.7	80	1.6	5.64	6,5	2	X	X	X	X	
VN220	 	11	349.6	108	18.55 4.64	9.27 2.77	6,5	2	X	X	X	X	X
VN260		13	58.8	22	-	-	6,5	6	X	X	X	X	
VL59		13	50	-	-	-	6	20		X			

BR = BRUT - BRUT - ROH - BRUT

AN = ANODISATIE - ANODISE - ELOXIERT - ANODISED

KL = STANDAARDKLEUREN - COULEUR STANDARD - BASIS FARBEN - BASIC COLORS

GS = GEMOFFELD SPECIAAL - LAQUE SPECIAL - SPECIALFARBE - SPECIAL COLOR

M1 = BICOLOR - BICOLOR - BICOLOR - BICOLOR

BUITENADER
PROFIL D'ENCADREMENT
KADERPROFILE
OUTER FRAME

PROFIELEN - PROFILS- PROFILE - PROFILES

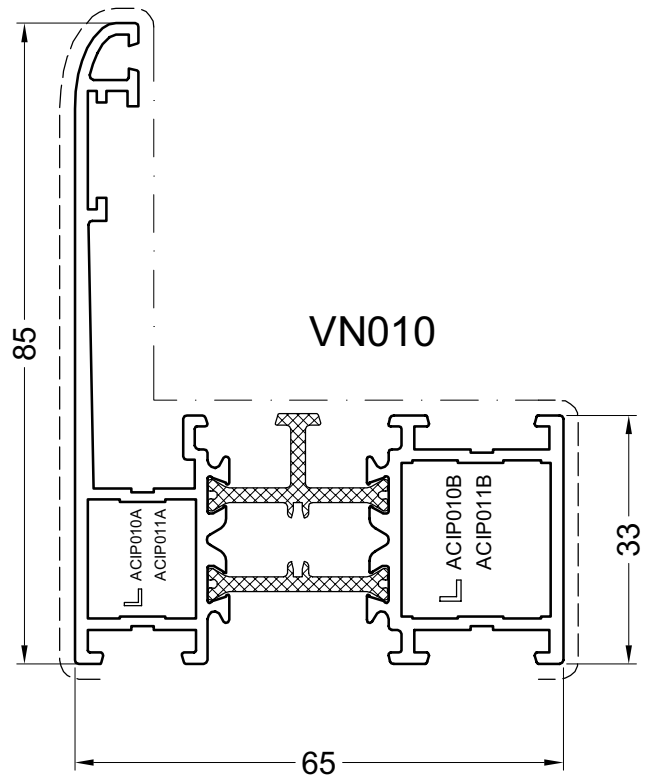

vna01

Primaire zichtbare zijde
Face visible primaire
Primär sichtbare Seite
Primary visible side

Secundaire zichtbare zijde
Face visible secondaire
Secondär sichtbare Seite
Secondary visible side

VLEUGELPROFIELEN
OUVRANTS
FLUGELPROFILE
VENT PROFILES

PROFIELEN - PROFILS - PROFILE - PROFILES

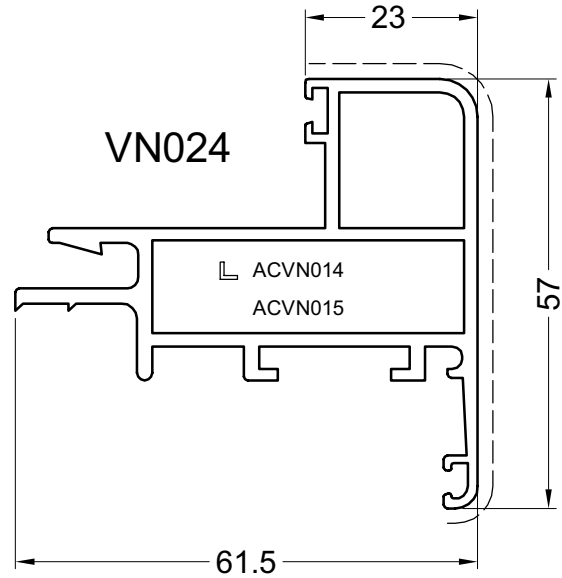
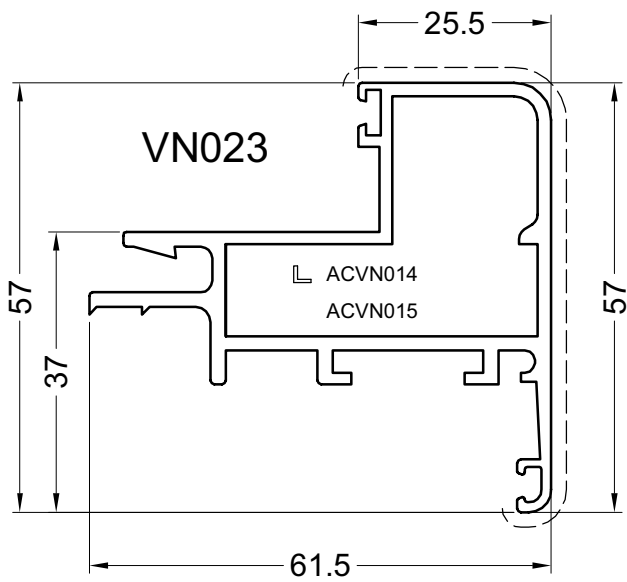
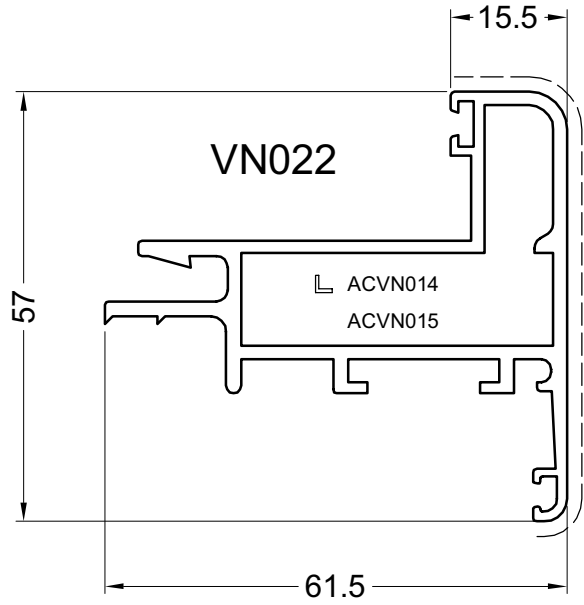
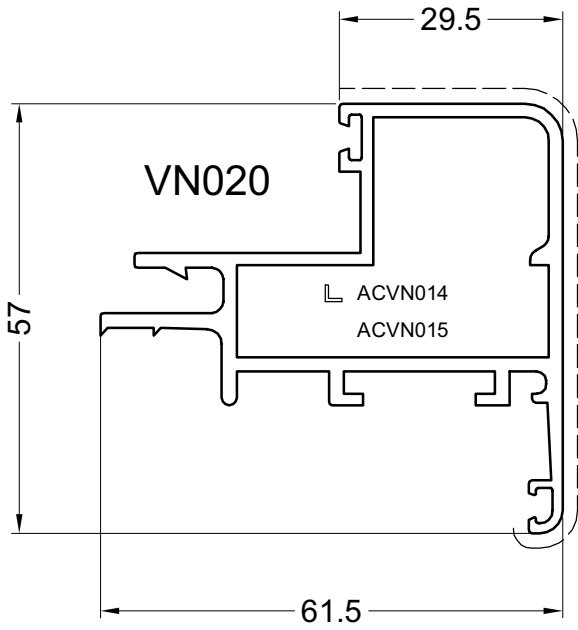

vna01a

THERMISCH VLEUGELPROFIEL
OUVRANT THERMIQUE
THERMISCH FLUGELPROFIL
THERMIC WINDOW PROFILE

PROFIELEN - PROFILS- PROFILE - PROFILES

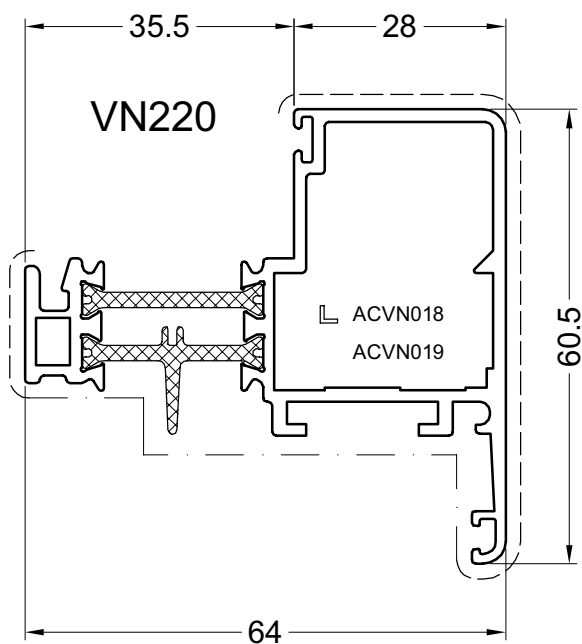

vna03

Primaire zichtbare zijde
Face visible primaire
Primär sichtbare Seite
Primary visible side

Secundaire zichtbare zijde
Face visible secondaire
Secondär sichtbare Seite
Secondary visible side

19/9/06

TUSSENREGELS
TRAVERS
SPROSSENPROFILE
TRANSOMS

PROFIELEN - PROFILS- PROFILE - PROFILES

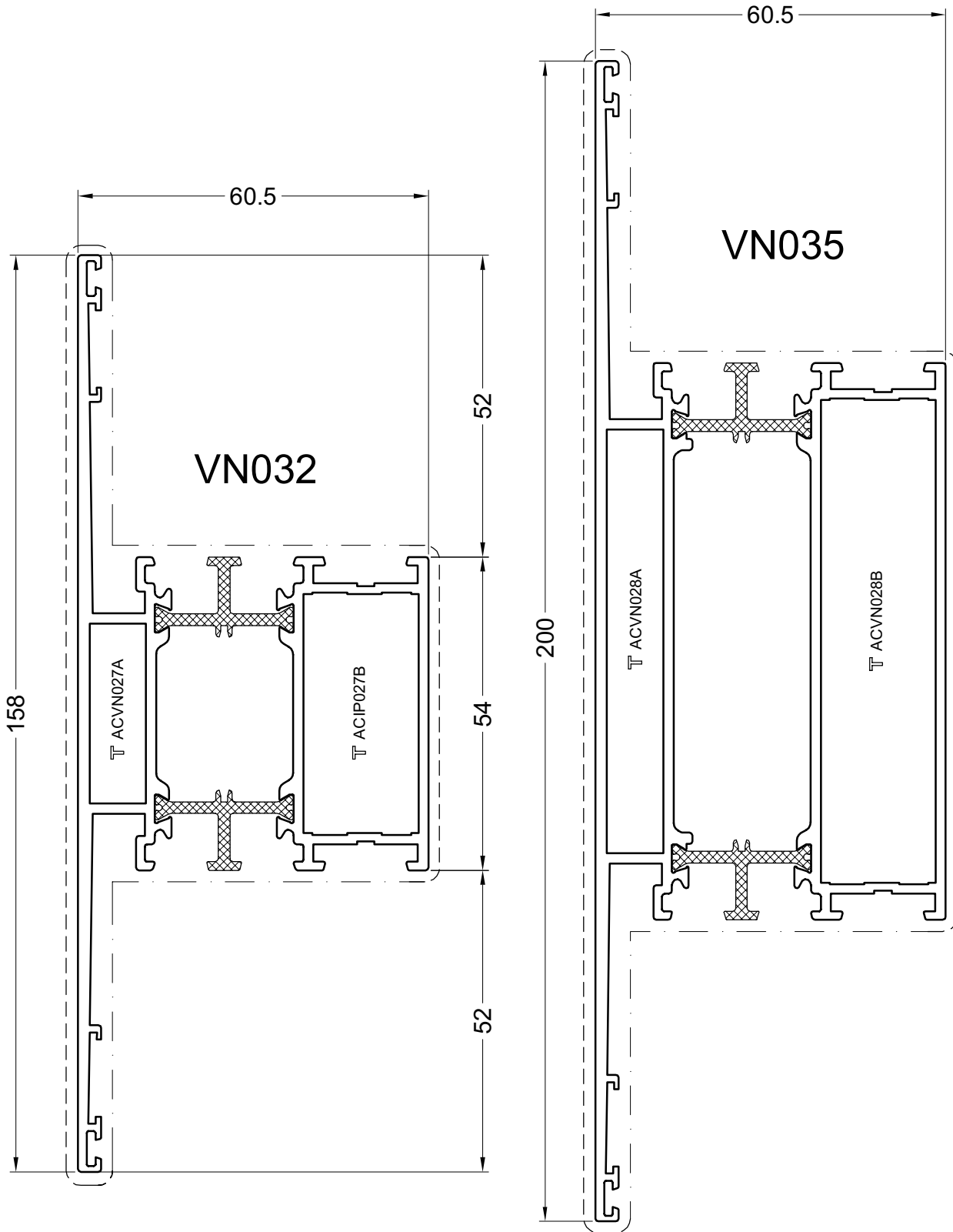

vna04

GLASLATTEN
LATTES A VITRAGE
GLASLEISTE
GLAZING BEADS

PROFIELEN - PROFILS- PROFILE - PROFILES

VL59

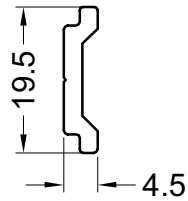

VN161

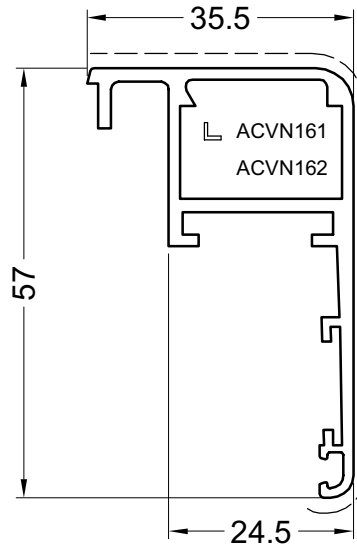

VN164

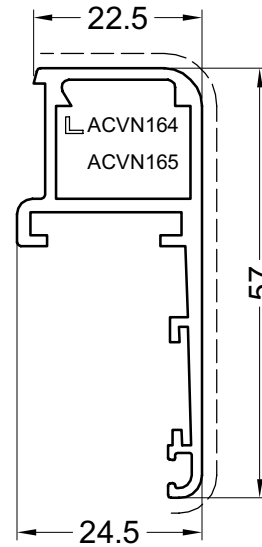

VN260

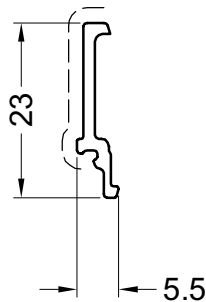



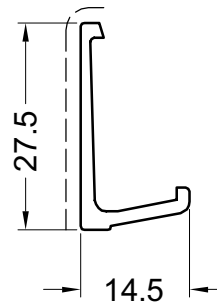



VN162

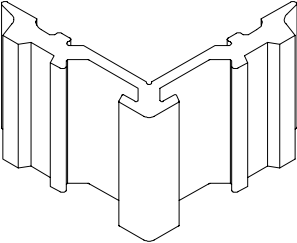
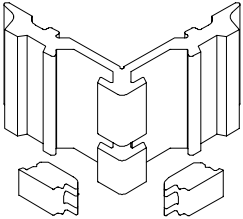

vna02

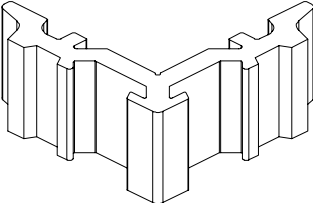
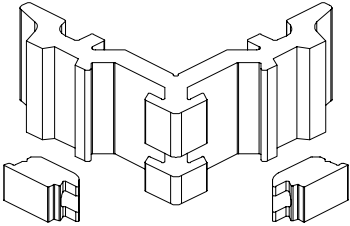
Primaire zichtbare zijde
Face visible primaire
Primär sichtbare Seite
Primary visible side

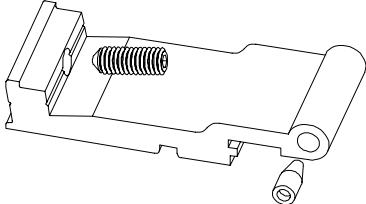
Secundaire zichtbare zijde
Face visible secondaire
Secondär sichtbare Seite
Secondary visible side

	Verp. per Emb. par Pack pr.	Einheid Unit	Toepassing Application	Kleur Couleur												
 <p>ACVN014 -Pershoek -Clame à presser -Eckverbinder Stanzbar -Clamping corner</p> <p>X=12mm Y=41mm</p>	1 24	Stuk Pièce Stück Pièce	VN020	<table border="1"> <tr><td>BR</td><td></td></tr> <tr><td>AN</td><td></td></tr> <tr><td>KL</td><td></td></tr> <tr><td>GS</td><td></td></tr> <tr><td>Z</td><td></td></tr> <tr><td>W</td><td></td></tr> </table>	BR		AN		KL		GS		Z		W	
BR																
AN																
KL																
GS																
Z																
W																
 <p>ACVN015 -Schroefhoek -Clame à visser -Eckverbinder Schraubbar -Square clamping joint</p> <p>X=12mm Y=41mm</p>  ACVG66	1 24	Stuk Pièce Stück Pièce	VN020	<table border="1"> <tr><td>BR</td><td></td></tr> <tr><td>AN</td><td></td></tr> <tr><td>KL</td><td></td></tr> <tr><td>GS</td><td></td></tr> <tr><td>Z</td><td></td></tr> <tr><td>W</td><td></td></tr> </table>	BR		AN		KL		GS		Z		W	
BR																
AN																
KL																
GS																
Z																
W																
 <p>ACVN018 -Pershoek -Clame à presser -Eckverbinder Stanzbar -Clamping corner</p> <p>X=15mm Y=28mm</p>	1	Stuk Pièce Stück Pièce	VN220	<table border="1"> <tr><td>BR</td><td></td></tr> <tr><td>AN</td><td></td></tr> <tr><td>KL</td><td></td></tr> <tr><td>GS</td><td></td></tr> <tr><td>Z</td><td></td></tr> <tr><td>W</td><td></td></tr> </table>	BR		AN		KL		GS		Z		W	
BR																
AN																
KL																
GS																
Z																
W																
 <p>ACVN019 -Schroefhoek -Clame à visser -Eckverbinder Schraubbar -Square clamping joint</p> <p>X=15mm Y=28mm</p>  ACVG66	1	Stuk Pièce Stück Pièce	VN220	<table border="1"> <tr><td>BR</td><td></td></tr> <tr><td>AN</td><td></td></tr> <tr><td>KL</td><td></td></tr> <tr><td>GS</td><td></td></tr> <tr><td>Z</td><td></td></tr> <tr><td>W</td><td></td></tr> </table>	BR		AN		KL		GS		Z		W	
BR																
AN																
KL																
GS																
Z																
W																
 <p>ACVN027A -T-verbinder voor buitenste kamer -Assemblage T pour chambre extérieure -T-verbinder für aussere kamer -Connecting bracket for outside chamber</p> <p>X=31mm Y=14mm</p>  ACVG66	1	Stuk Pièce Stück Pièce	VN032	<table border="1"> <tr><td>BR</td><td></td></tr> <tr><td>AN</td><td></td></tr> <tr><td>KL</td><td></td></tr> <tr><td>GS</td><td></td></tr> <tr><td>Z</td><td></td></tr> <tr><td>W</td><td></td></tr> </table>	BR		AN		KL		GS		Z		W	
BR																
AN																
KL																
GS																
Z																
W																

BR = BRUT - BRUT - ROH - BRUT
 AN (X) = ANODISATIE - ANODISE - ELOXIERT - ANODISED
 AN (■) = GELAKT - LAQUE - LACKIERT - LACQUERED -- RAL9006M
 KL = STANDAARDKLEUREN - COULEUR STANDARD - BASIS FARBEN - BASIC COLORS
 GS = GEMOFFELD SPECIAAL - LAQUE SPECIAL - SPECIALFARBE - SPECIAL COLOR
 Z = ZWART - NOIR - SCHWARZ - BLACK
 W = WIT - BLANC - WEISS - WHITE







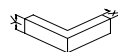

GEREEDSCHAP - OUTILLAGE
WERKZEUG - TOOL



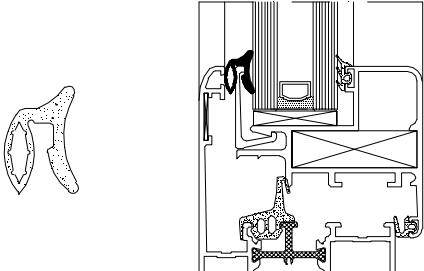
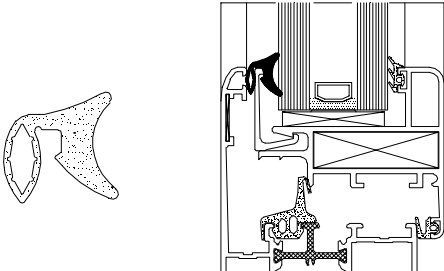
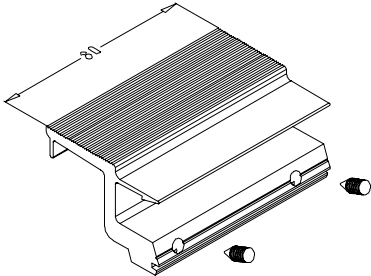

BEVESTIGING - FIXATION
BEFESTIGUNG - FIXATION







		Verp. per Emb. par Pack pr. Pack pr.	Eenheid Unité Einheit Unit	Toepassing Application Anwendung Application	Kleur Couleur Farbe Color												
 <p>X=73mm Y=13mm</p>	<p>ACVN028A</p> <p>-T-verbinder voor buitenste kamer -Assemblage T pour chambre extérieure -T-verbinder für aussere kammer -Connecting bracket for outside chamber</p> <p> ACVG66</p>	1	Stuk Pièce Stück Piece	VN035	<table border="1"> <tr><td>BR</td><td></td></tr> <tr><td>AN</td><td></td></tr> <tr><td>KL</td><td></td></tr> <tr><td>GS</td><td></td></tr> <tr><td>Z</td><td></td></tr> <tr><td>W</td><td></td></tr> </table>	BR		AN		KL		GS		Z		W	
BR																	
AN																	
KL																	
GS																	
Z																	
W																	
 <p>X=83mm Y=20mm</p>	<p>ACVN028B</p> <p>-T-verbinder voor binnenste kamer -Assemblage T pour chambre intérieure -T-verbinder für innere kammer -Connecting bracket for inside chamber</p> <p> ACVG66</p>	1	Stuk Pièce Stück Piece	VN035	<table border="1"> <tr><td>BR</td><td></td></tr> <tr><td>AN</td><td></td></tr> <tr><td>KL</td><td></td></tr> <tr><td>GS</td><td></td></tr> <tr><td>Z</td><td></td></tr> <tr><td>W</td><td></td></tr> </table>	BR		AN		KL		GS		Z		W	
BR																	
AN																	
KL																	
GS																	
Z																	
W																	
	<p>ACVN032</p> <p>-Buitenbeglazingsrubber vleugel 3mm -Joint de vitrage extérieur ouvrant 3mm -Dichtung flügel aussen verglazung 3mm -Gasket for outside glazing 3mm</p>	100	m	VN162	<table border="1"> <tr><td>BR</td><td></td></tr> <tr><td>AN</td><td></td></tr> <tr><td>KL</td><td></td></tr> <tr><td>GS</td><td></td></tr> <tr><td>Z</td><td></td></tr> <tr><td>W</td><td></td></tr> </table>	BR		AN		KL		GS		Z		W	
BR																	
AN																	
KL																	
GS																	
Z																	
W																	
	<p>ACVN034</p> <p>-Buitenbeglazingsrubber vleugel 5mm -Joint de vitrage extérieur ouvrant 5mm -Dichtung flügel aussen verglazung 5mm -Gasket for outside glazing 5mm</p>	100	m	VN162	<table border="1"> <tr><td>BR</td><td></td></tr> <tr><td>AN</td><td></td></tr> <tr><td>KL</td><td></td></tr> <tr><td>GS</td><td></td></tr> <tr><td>Z</td><td></td></tr> <tr><td>W</td><td></td></tr> </table>	BR		AN		KL		GS		Z		W	
BR																	
AN																	
KL																	
GS																	
Z																	
W																	
	<p>ACVN057</p> <p>-Bevestiging voor glaslat + glassteun 80mm -Fixation latte a vitrage + sup. vitrage 80mm -Fixierung für glasteile und verlotzungs auflage 80mm -Fixing for clip glazing and glazing support 80mm</p> <p> ACVG65</p>	1	Stuk Pièce Stück Piece	VN161 VN164	<table border="1"> <tr><td>BR</td><td></td></tr> <tr><td>AN</td><td></td></tr> <tr><td>KL</td><td></td></tr> <tr><td>GS</td><td></td></tr> <tr><td>Z</td><td></td></tr> <tr><td>W</td><td></td></tr> </table>	BR		AN		KL		GS		Z		W	
BR																	
AN																	
KL																	
GS																	
Z																	
W																	



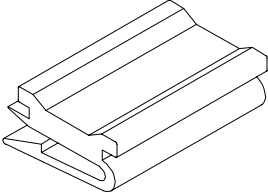
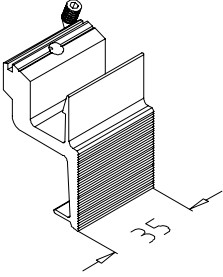

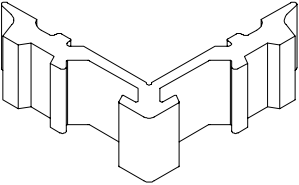
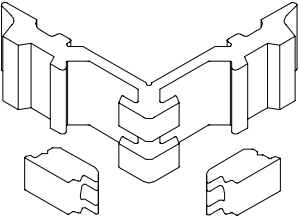

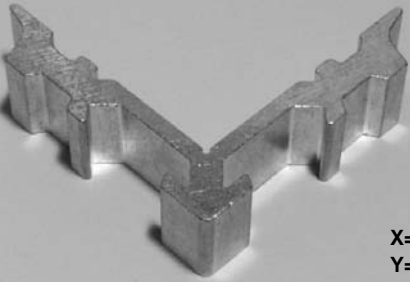

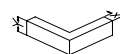
BR = BRUT - BRUT - ROH - BRUT
 AN (X) = ANODISATIE - ANODISE - ELOXIERT - ANODISED
 AN (■) = GELAKT - LAQUE - LACKIERT - LACQUERED -- RAL9006M
 KL = STANDAARDKLEUREN - COULEUR STANDARD - BASIS FARBEN - BASIC COLORS
 GS = GEMOFFELD SPECIAAL - LAQUE SPECIAL - SPECIALFARBE - SPECIAL COLOR
 Z = ZWART - NOIR - SCHWARZ - BLACK
 W = WIT - BLANC - WEISS - WHITE

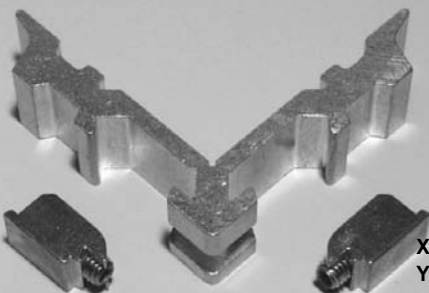
 GEREEDSCHAP - OUTILLAGE
 WERKZEUG - TOOL
 BEVESTIGING - FIXATION
 BEFESTIGUNG - FIXATION



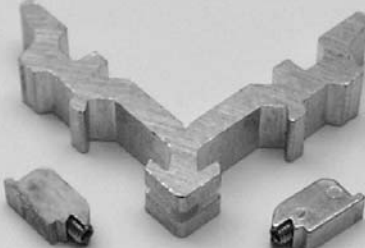

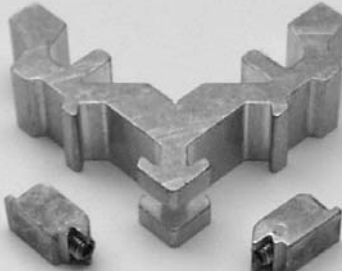
		Verp. per Emb. par Pack pr.	Einheid Unité Einheit Unit	Toepassing Application Anwendung Application	Kleur Couleur Farbe Color												
	ACVN058 -Klemstukje glaslat B=30mm -Clip latte a vitrage pour B=30mm -Befestigungsklotz für glasteile B=30mm -Clip glazing bead B=30mm	1	Stuk Pièce Stück Piece	VN161 VN164	<table border="1"> <tr><td>BR</td><td></td></tr> <tr><td>AN</td><td></td></tr> <tr><td>KL</td><td></td></tr> <tr><td>GS</td><td></td></tr> <tr><td>Z</td><td></td></tr> <tr><td>W</td><td></td></tr> </table>	BR		AN		KL		GS		Z		W	
BR																	
AN																	
KL																	
GS																	
Z																	
W																	
	ACVN059 -Bevestiging voor glaslat + glassteun 35mm -Fixation latte a vitrage + sup. vitrage 35mm -Fixierung für glasteile und verlotzungs auflage 35mm -Fixing for clip glazing and glazing support 35mm  ACVG65	1	Stuk Pièce Stück Piece	VN161 VN164	<table border="1"> <tr><td>BR</td><td></td></tr> <tr><td>AN</td><td></td></tr> <tr><td>KL</td><td></td></tr> <tr><td>GS</td><td></td></tr> <tr><td>Z</td><td></td></tr> <tr><td>W</td><td></td></tr> </table>	BR		AN		KL		GS		Z		W	
BR																	
AN																	
KL																	
GS																	
Z																	
W																	
 X=12mm Y=21mm	ACVN161 -Pershoek -Clame à presser -Eckverbinder Stanzbar -Clamping corner	1 24	Stuk Pièce Stück Piece	VN161	<table border="1"> <tr><td>BR</td><td></td></tr> <tr><td>AN</td><td></td></tr> <tr><td>KL</td><td></td></tr> <tr><td>GS</td><td></td></tr> <tr><td>Z</td><td></td></tr> <tr><td>W</td><td></td></tr> </table>	BR		AN		KL		GS		Z		W	
BR																	
AN																	
KL																	
GS																	
Z																	
W																	
 X=12mm Y=21mm	ACVN162 -Schroefhoek -Clame à visser -Eckverbinder Schraubbar -Square clamping joint  ACVG66	1 24	Stuk Pièce Stück Piece	VN161	<table border="1"> <tr><td>BR</td><td></td></tr> <tr><td>AN</td><td></td></tr> <tr><td>KL</td><td></td></tr> <tr><td>GS</td><td></td></tr> <tr><td>Z</td><td></td></tr> <tr><td>W</td><td></td></tr> </table>	BR		AN		KL		GS		Z		W	
BR																	
AN																	
KL																	
GS																	
Z																	
W																	
 X=12mm Y=17mm	ACVN164 -Pershoek -Clame à presser -Eckverbinder Stanzbar -Clamping corner	1	Stuk Pièce Stück Piece	VN164	<table border="1"> <tr><td>BR</td><td></td></tr> <tr><td>AN</td><td></td></tr> <tr><td>KL</td><td></td></tr> <tr><td>GS</td><td></td></tr> <tr><td>Z</td><td></td></tr> <tr><td>W</td><td></td></tr> </table>	BR		AN		KL		GS		Z		W	
BR																	
AN																	
KL																	
GS																	
Z																	
W																	







		Verp. per Emb. par Pack pr. Pack pr.	Eenheid Unité Einheit Unit	Toepassing Application Anwendung Application	Kleur Couleur Farbe Color												
 <p>X=12mm Y=17mm</p>	<p>ACVN165</p> <p>-Schroefhoek -Clame à visser -Eckverbinder Schraubbar -Square clamping joint</p> <p> ACVG66</p>	1	Stuk Pièce Stück Piece	VN164	<table border="1"> <tr><td>BR</td><td></td></tr> <tr><td>AN</td><td></td></tr> <tr><td>KL</td><td></td></tr> <tr><td>GS</td><td></td></tr> <tr><td>Z</td><td></td></tr> <tr><td>W</td><td></td></tr> </table>	BR		AN		KL		GS		Z		W	
BR																	
AN																	
KL																	
GS																	
Z																	
W																	
 <p>X=15mm Y=14mm</p>	<p>ACIP010A</p> <p>-Pershoek voor buitenste kamer -Clame à presser pour chambre extérieure -Eckverbinder Stanzbar für aussere kammer -Clamping corner for outside chamber</p>	1 48	Stuk Pièce Stück Piece	VN010	<table border="1"> <tr><td>BR</td><td></td></tr> <tr><td>AN</td><td></td></tr> <tr><td>KL</td><td></td></tr> <tr><td>GS</td><td></td></tr> <tr><td>Z</td><td></td></tr> <tr><td>W</td><td></td></tr> </table>	BR		AN		KL		GS		Z		W	
BR																	
AN																	
KL																	
GS																	
Z																	
W																	
 <p>X=20mm Y=20mm</p>	<p>ACIP010B</p> <p>-Pershoek voor binnenste kamer -Clame à presser pour chambre intérieure -Eckverbinder Stanzbar für innere kammer -Clamping corner for inside chamber</p>	1 48	Stuk Pièce Stück Piece	VN010	<table border="1"> <tr><td>BR</td><td></td></tr> <tr><td>AN</td><td></td></tr> <tr><td>KL</td><td></td></tr> <tr><td>GS</td><td></td></tr> <tr><td>Z</td><td></td></tr> <tr><td>W</td><td></td></tr> </table>	BR		AN		KL		GS		Z		W	
BR																	
AN																	
KL																	
GS																	
Z																	
W																	
 <p>X=15mm Y=14mm</p>	<p>ACIP011A</p> <p>-Schroefhoek voor buitenste kamer -Clame à visser pour chambre extérieure -Eckverbinder Schraubbar für aussere kammer -Square coupling joint for outside chamber</p> <p> ACVG65</p>	1 48	Stuk Pièce Stück Piece	VN010	<table border="1"> <tr><td>BR</td><td></td></tr> <tr><td>AN</td><td></td></tr> <tr><td>KL</td><td></td></tr> <tr><td>GS</td><td></td></tr> <tr><td>Z</td><td></td></tr> <tr><td>W</td><td></td></tr> </table>	BR		AN		KL		GS		Z		W	
BR																	
AN																	
KL																	
GS																	
Z																	
W																	
 <p>X=20mm Y=20mm</p>	<p>ACIP011B</p> <p>-Schroefhoek voor binnenste kamer -Clame à visser pour chambre intérieure -Eckverbinder Schraubbar für innere kammer -Square coupling joint for inside chamber</p> <p> ACVG66</p>	1 48	Stuk Pièce Stück Piece	VN010	<table border="1"> <tr><td>BR</td><td></td></tr> <tr><td>AN</td><td></td></tr> <tr><td>KL</td><td></td></tr> <tr><td>GS</td><td></td></tr> <tr><td>Z</td><td></td></tr> <tr><td>W</td><td></td></tr> </table>	BR		AN		KL		GS		Z		W	
BR																	
AN																	
KL																	
GS																	
Z																	
W																	



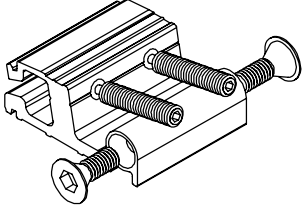

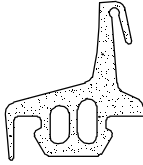
BR = BRUT - BRUT - ROH - BRUT
 AN (X) = ANODISATIE - ANODISE - ELOXIERT - ANODISED
 AN (■) = GELAKT - LAQUE - LACKIERT - LACQUERED -- RAL9006M
 KL = STANDAARDKLEUREN - COULEUR STANDARD - BASIS FARBEN - BASIC COLORS
 GS = GEMOFFELD SPECIAAL - LAQUE SPECIAL - SPECIALFARBE - SPECIAL COLOR
 Z = ZWART - NOIR - SCHWARZ - BLACK
 W = WIT - BLANC - WEISS - WHITE

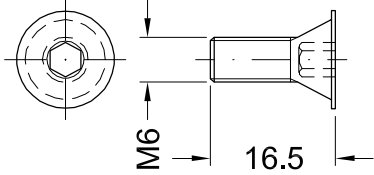
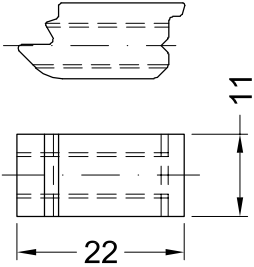
 GEREEDSCHAP - OUTILLAGE
 WERKZEUG - TOOL
 BEVESTIGING - FIXATION
 BEFESTIGUNG - FIXATION

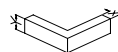

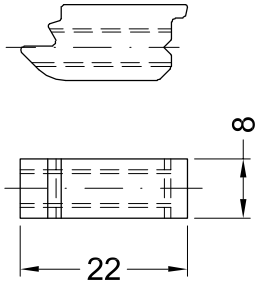
		Verp. per Emb. par Pack pr.	Einheid Unité Einheit Unit	Toepassing Application Anwendung Application	Kleur Couleur Farbe Color											
 <p>ACIP027B -T-verbinding voor binnenste kamer -Assemblage T pour chambre interieure -T-Verbinder für innere kammer -Connecting bracket for inside chamber</p> <p>X=41mm Y=20mm</p>  <p>ACVG66 + ACVL150</p>	1	Stuk Pièce Stück Pièce	VN032	<table border="1"> <tr><td>BR</td><td></td></tr> <tr><td>AN</td><td></td></tr> <tr><td>KL</td><td></td></tr> <tr><td>GS</td><td></td></tr> <tr><td>Z</td><td></td></tr> <tr><td>W</td><td></td></tr> </table>	BR		AN		KL		GS		Z		W	
BR																
AN																
KL																
GS																
Z																
W																
 <p>ACIP030 -Middendichting -Joint central -Mitteldichtung -Central gasket</p>	100	m	VN010 VN032 VN035	<table border="1"> <tr><td>BR</td><td></td></tr> <tr><td>AN</td><td></td></tr> <tr><td>KL</td><td></td></tr> <tr><td>GS</td><td></td></tr> <tr><td>Z</td><td></td></tr> <tr><td>W</td><td></td></tr> </table>	BR		AN		KL		GS		Z		W	
BR																
AN																
KL																
GS																
Z																
W																
 <p>ACMX040 -Scharnier -Paumelle -Band -Hinge</p>	2	Stuk Pièce Stück Pièce	VN020 VN022	<table border="1"> <tr><td>BR</td><td>X</td></tr> <tr><td>AN</td><td>X</td></tr> <tr><td>KL</td><td>X</td></tr> <tr><td>GS</td><td>X</td></tr> <tr><td>Z</td><td>X</td></tr> <tr><td>W</td><td>X</td></tr> </table>	BR	X	AN	X	KL	X	GS	X	Z	X	W	X
BR	X															
AN	X															
KL	X															
GS	X															
Z	X															
W	X															
 <p>ACMX852 -Schroef voor T-verbinders -Vis pour assemblage T -Schraube für T-Verbinder -Screw for connecting bracket</p> <p>M6 16.5</p>	48	Stuk Pièce Stück Pièce		<table border="1"> <tr><td>BR</td><td></td></tr> <tr><td>AN</td><td></td></tr> <tr><td>KL</td><td></td></tr> <tr><td>GS</td><td></td></tr> <tr><td>Z</td><td></td></tr> <tr><td>W</td><td></td></tr> </table>	BR		AN		KL		GS		Z		W	
BR																
AN																
KL																
GS																
Z																
W																
 <p>ACMX853 -Schroefblokje 11mm -Clavet 11mm -Schraubeblock 11mm -Cleat tensioning block 11mm</p> <p>11 22</p>	48	Stuk Pièce Stück Pièce		<table border="1"> <tr><td>BR</td><td></td></tr> <tr><td>AN</td><td></td></tr> <tr><td>KL</td><td></td></tr> <tr><td>GS</td><td></td></tr> <tr><td>Z</td><td></td></tr> <tr><td>W</td><td></td></tr> </table>	BR		AN		KL		GS		Z		W	
BR																
AN																
KL																
GS																
Z																
W																

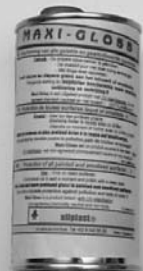

		Verp. per Emb. par Pack pr. Pack pr.	Eenheid Unité Einheit Unit	Toepassing Application Anwendung Application	Kleur Couleur Farbe Color												
	<p>ACMX854</p> <ul style="list-style-type: none"> -Schroefblokje 8mm -Clavet 8mm -Schraubeblock 8mm -Cleat tensioning block 8mm 	48	Stuk Pièce Stück Pièce		<table border="1"> <tr><td>BR</td><td></td></tr> <tr><td>AN</td><td></td></tr> <tr><td>KL</td><td></td></tr> <tr><td>GS</td><td></td></tr> <tr><td>Z</td><td></td></tr> <tr><td>W</td><td></td></tr> </table>	BR		AN		KL		GS		Z		W	
BR																	
AN																	
KL																	
GS																	
Z																	
W																	
	<p>ACMX09700</p> <ul style="list-style-type: none"> -Alu-polish -Alu-polish -Alu-polish -Alu-polish <p>750ml</p>	1	Stuk Pièce Stück Pièce		<table border="1"> <tr><td>BR</td><td></td></tr> <tr><td>AN</td><td></td></tr> <tr><td>KL</td><td></td></tr> <tr><td>GS</td><td></td></tr> <tr><td>Z</td><td></td></tr> <tr><td>W</td><td></td></tr> </table>	BR		AN		KL		GS		Z		W	
BR																	
AN																	
KL																	
GS																	
Z																	
W																	
	<p>ACMX09761</p> <ul style="list-style-type: none"> -Maxi-gloss -Maxi-gloss -Maxi-gloss -Maxi-gloss <p>500ml</p>	1	Stuk Pièce Stück Pièce		<table border="1"> <tr><td>BR</td><td></td></tr> <tr><td>AN</td><td></td></tr> <tr><td>KL</td><td></td></tr> <tr><td>GS</td><td></td></tr> <tr><td>Z</td><td></td></tr> <tr><td>W</td><td></td></tr> </table>	BR		AN		KL		GS		Z		W	
BR																	
AN																	
KL																	
GS																	
Z																	
W																	
	<p>ACMX09762</p> <ul style="list-style-type: none"> -Periodi-clean -Periodi-clean -Periodi-clean -Periodi-clean <p>500ml</p>	1	Stuk Pièce Stück Pièce		<table border="1"> <tr><td>BR</td><td></td></tr> <tr><td>AN</td><td></td></tr> <tr><td>KL</td><td></td></tr> <tr><td>GS</td><td></td></tr> <tr><td>Z</td><td></td></tr> <tr><td>W</td><td></td></tr> </table>	BR		AN		KL		GS		Z		W	
BR																	
AN																	
KL																	
GS																	
Z																	
W																	
	<p>ACMX09763</p> <ul style="list-style-type: none"> -Teflon spray -Teflon spray -Teflon spray -Teflon spray <p>400ml</p>	1	Stuk Pièce Stück Pièce		<table border="1"> <tr><td>BR</td><td></td></tr> <tr><td>AN</td><td></td></tr> <tr><td>KL</td><td></td></tr> <tr><td>GS</td><td></td></tr> <tr><td>Z</td><td></td></tr> <tr><td>W</td><td></td></tr> </table>	BR		AN		KL		GS		Z		W	
BR																	
AN																	
KL																	
GS																	
Z																	
W																	

BR = BRUT - BRUT - ROH - BRUT
 AN (X) = ANODISATIE - ANODISE - ELOXIERT - ANODISED
 AN (■) = GELAKT - LAQUE - LACKIERT - LACQUERED -- RAL9006M
 KL = STANDAARDKLEUREN - COULEUR STANDARD - BASIS FARBEN - BASIC COLORS
 GS = GEMOFFELD SPECIAAL - LAQUE SPECIAL - SPECIALFARBE - SPECIAL COLOR
 Z = ZWART - NOIR - SCHWARZ - BLACK
 W = WIT - BLANC - WEISS - WHITE



GEREEDSCHAP - OUTILLAGE
 WERKZEUG - TOOL



BEVESTIGING - FIXATION
 BEFESTIGUNG - FIXATION

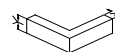

		Verp. per Emb. par Pack pr.	Einheid Unité Einheit Unit	Toepassing Application Anwendung Application	Kleur Couleur Farbe Color												
	ACMX09764 -Maxi-cleaner -Maxi-cleaner -Maxi-cleaner -Maxi-cleaner 500ml	1	Stuk Pièce Stück Pièce		<table border="1"> <tr><td>BR</td><td></td></tr> <tr><td>AN</td><td></td></tr> <tr><td>KL</td><td></td></tr> <tr><td>GS</td><td></td></tr> <tr><td>Z</td><td></td></tr> <tr><td>W</td><td></td></tr> </table>	BR		AN		KL		GS		Z		W	
BR																	
AN																	
KL																	
GS																	
Z																	
W																	
	ACMX09765 -Glue-cleaner -Glue-cleaner -Glue-cleaner -Glue-cleaner 500ml	1	Stuk Pièce Stück Pièce		<table border="1"> <tr><td>BR</td><td></td></tr> <tr><td>AN</td><td></td></tr> <tr><td>KL</td><td></td></tr> <tr><td>GS</td><td></td></tr> <tr><td>Z</td><td></td></tr> <tr><td>W</td><td></td></tr> </table>	BR		AN		KL		GS		Z		W	
BR																	
AN																	
KL																	
GS																	
Z																	
W																	
	ACMX09766 -Surface activator -Surface activator -Surface activator -Surface activator 1l	1	Stuk Pièce Stück Pièce		<table border="1"> <tr><td>BR</td><td></td></tr> <tr><td>AN</td><td></td></tr> <tr><td>KL</td><td></td></tr> <tr><td>GS</td><td></td></tr> <tr><td>Z</td><td></td></tr> <tr><td>W</td><td></td></tr> </table>	BR		AN		KL		GS		Z		W	
BR																	
AN																	
KL																	
GS																	
Z																	
W																	
	ACMX09767 -Anti-stone opgepast voor natuursteen en metselwerk attention pour pierre de taille et maçonnerie achtung für Naturstein und Mauerwerk attention for natural stone and bricklaying 500ml	1	Stuk Pièce Stück Pièce		<table border="1"> <tr><td>BR</td><td></td></tr> <tr><td>AN</td><td></td></tr> <tr><td>KL</td><td></td></tr> <tr><td>GS</td><td></td></tr> <tr><td>Z</td><td></td></tr> <tr><td>W</td><td></td></tr> </table>	BR		AN		KL		GS		Z		W	
BR																	
AN																	
KL																	
GS																	
Z																	
W																	
	ACMX09770 -Rol andywrap 100mm -Rouleau andywrap 100mm -Rolle andywrap 100mm -Roll andywrap 100mm	150	m		<table border="1"> <tr><td>BR</td><td></td></tr> <tr><td>AN</td><td></td></tr> <tr><td>KL</td><td></td></tr> <tr><td>GS</td><td></td></tr> <tr><td>Z</td><td></td></tr> <tr><td>W</td><td></td></tr> </table>	BR		AN		KL		GS		Z		W	
BR																	
AN																	
KL																	
GS																	
Z																	
W																	

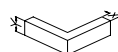

		Verp. per Emb. par Pack pr. Pack pr.	Eenheid Unité Einheit Unit	Toepassing Application Anwendung Application	Kleur Couleur Farbe Color												
	ACMX09775 -Houder andywrap -Manche andywrap -Halter andywrap -Grip andywrap	1	Stuk Pièce Stück Pièce		<table border="1"> <tr><td>BR</td><td></td></tr> <tr><td>AN</td><td></td></tr> <tr><td>KL</td><td></td></tr> <tr><td>GS</td><td></td></tr> <tr><td>Z</td><td></td></tr> <tr><td>W</td><td></td></tr> </table>	BR		AN		KL		GS		Z		W	
BR																	
AN																	
KL																	
GS																	
Z																	
W																	
	ACMX09801 -Beschermtape 50mm (500m) -Tape de protection 50mm (500m) -Schutz klebeband 50mm (500m) -Protective tape 50mm (500m)	1	Stuk Pièce Stück Pièce		<table border="1"> <tr><td>BR</td><td></td></tr> <tr><td>AN</td><td></td></tr> <tr><td>KL</td><td></td></tr> <tr><td>GS</td><td></td></tr> <tr><td>Z</td><td></td></tr> <tr><td>W</td><td></td></tr> </table>	BR		AN		KL		GS		Z		W	
BR																	
AN																	
KL																	
GS																	
Z																	
W																	
	ACMX09802 -Beschermtape 70mm (500m) -Tape de protection 70mm (500m) -Schutz klebeband 70mm (500m) -Protective tape 70mm (500m)	1	Stuk Pièce Stück Pièce		<table border="1"> <tr><td>BR</td><td></td></tr> <tr><td>AN</td><td></td></tr> <tr><td>KL</td><td></td></tr> <tr><td>GS</td><td></td></tr> <tr><td>Z</td><td></td></tr> <tr><td>W</td><td></td></tr> </table>	BR		AN		KL		GS		Z		W	
BR																	
AN																	
KL																	
GS																	
Z																	
W																	
	ACMX09803 -Beschermtape 100mm (500m) -Tape de protection 100mm (500m) -Schutz klebeband 100mm (500m) -Protective tape 100mm (500m)	1	Stuk Pièce Stück Pièce		<table border="1"> <tr><td>BR</td><td></td></tr> <tr><td>AN</td><td></td></tr> <tr><td>KL</td><td></td></tr> <tr><td>GS</td><td></td></tr> <tr><td>Z</td><td></td></tr> <tr><td>W</td><td></td></tr> </table>	BR		AN		KL		GS		Z		W	
BR																	
AN																	
KL																	
GS																	
Z																	
W																	
	ACMX09804 -Beschermtape 35mm (500m) -Tape de protection 35mm (500m) -Schutz klebeband 35mm (500m) -Protective tape 35mm (500m)	1	Stuk Pièce Stück Pièce		<table border="1"> <tr><td>BR</td><td></td></tr> <tr><td>AN</td><td></td></tr> <tr><td>KL</td><td></td></tr> <tr><td>GS</td><td></td></tr> <tr><td>Z</td><td></td></tr> <tr><td>W</td><td></td></tr> </table>	BR		AN		KL		GS		Z		W	
BR																	
AN																	
KL																	
GS																	
Z																	
W																	

BR = BRUT - BRUT - ROH - BRUT
AN (X) = ANODISATIE - ANODISE - ELOXIERT - ANODISED
AN (■) = GELAKT - LAQUE - LACKIERT - LACQUERED -- RAL9006M
KL = STANDAARDKLEUREN - COULEUR STANDARD - BASIS FARBEN - BASIC COLORS
GS = GEMOFFELD SPECIAAL - LAQUE SPECIAL - SPECIALFARBE - SPECIAL COLOR
Z = ZWART - NOIR - SCHWARZ - BLACK
W = WIT - BLANC - WEISS - WHITE



GEREEDSCHAP - OUTILLAGE
WERKZEUG - TOOL



BEVESTIGING - FIXATION
BEFESTIGUNG - FIXATION

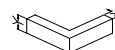



	Verp. per Emb. par Pack pr.	Einheid Unit	Toepassing Application	Kleur Couleur												
 <p>ACMX09830</p> <ul style="list-style-type: none"> -Kleefstof voor EPDM-rubbers -Colle pour EPDM-caoutchouc -Dichtmasse + klebestoff EPDM gummi -Gum for EPDM-rubber 	1	Stuk Pièce Stück Pièce	ACIP030 ACVG31	<table border="1"> <tr><td>BR</td><td></td></tr> <tr><td>AN</td><td></td></tr> <tr><td>KL</td><td></td></tr> <tr><td>GS</td><td></td></tr> <tr><td>Z</td><td>X</td></tr> <tr><td>W</td><td></td></tr> </table>	BR		AN		KL		GS		Z	X	W	
BR																
AN																
KL																
GS																
Z	X															
W																
 <p>ACSB049</p> <ul style="list-style-type: none"> -Sluitstuk -Gache -Schliesstück -Adjusting lock plate 	1	Stuk Pièce Stück Pièce		<table border="1"> <tr><td>BR</td><td></td></tr> <tr><td>AN</td><td></td></tr> <tr><td>KL</td><td></td></tr> <tr><td>GS</td><td></td></tr> <tr><td>Z</td><td></td></tr> <tr><td>W</td><td></td></tr> </table>	BR		AN		KL		GS		Z		W	
BR																
AN																
KL																
GS																
Z																
W																
 <p>ACSB050</p> <ul style="list-style-type: none"> -Set sluitpunten onder + boven OR -Points de verrouillage sup. + inf. OF -Riegelstücke zum einklemmen DF -Adjusting lock plates CW 	1	Stuk Pièce Stück Pièce		<table border="1"> <tr><td>BR</td><td></td></tr> <tr><td>AN</td><td></td></tr> <tr><td>KL</td><td></td></tr> <tr><td>GS</td><td></td></tr> <tr><td>Z</td><td></td></tr> <tr><td>W</td><td></td></tr> </table>	BR		AN		KL		GS		Z		W	
BR																
AN																
KL																
GS																
Z																
W																
 <p>ACSB051</p> <ul style="list-style-type: none"> -Oplooblokje -Patin -Auflaufstück -Sloped block 	1	Stuk Pièce Stück Pièce		<table border="1"> <tr><td>BR</td><td></td></tr> <tr><td>AN</td><td></td></tr> <tr><td>KL</td><td></td></tr> <tr><td>GS</td><td></td></tr> <tr><td>Z</td><td></td></tr> <tr><td>W</td><td></td></tr> </table>	BR		AN		KL		GS		Z		W	
BR																
AN																
KL																
GS																
Z																
W																
 <p>ACSB081</p> <ul style="list-style-type: none"> -Kruk DK -Poignee OB -Umschaltgetriebe DK -Handle TT 	1	Stuk Pièce Stück Pièce		<table border="1"> <tr><td>BR</td><td>X</td></tr> <tr><td>AN</td><td>X</td></tr> <tr><td>KL</td><td>X</td></tr> <tr><td>GS</td><td>X</td></tr> <tr><td>Z</td><td>X</td></tr> <tr><td>W</td><td>X</td></tr> </table>	BR	X	AN	X	KL	X	GS	X	Z	X	W	X
BR	X															
AN	X															
KL	X															
GS	X															
Z	X															
W	X															







		Verp. per Emb. par Pack pr. Pack pr.	Eenheid Unité Einheit Unit	Toepassing Application Anwendung Application	Kleur Couleur Farbe Color												
	<p>ACSB083</p> <p>-Meeneemstuk voor kruk DK -Pièce d'entraînement OB -Kupplungsflasche für DK -Connection piece for TT</p>	1	Stuk Pièce Stück Piece		<table border="1"> <tr><td>BR</td><td></td></tr> <tr><td>AN</td><td></td></tr> <tr><td>KL</td><td></td></tr> <tr><td>GS</td><td></td></tr> <tr><td>Z</td><td></td></tr> <tr><td>W</td><td></td></tr> </table>	BR		AN		KL		GS		Z		W	
BR																	
AN																	
KL																	
GS																	
Z																	
W																	
	<p>ACSIL04</p> <p>-Afdichtingslijmkit voor versteknaden -Joint d'étanchéité pour onglets -Leim für abdichtung -Sealingglue</p>	1	Stuk Pièce Stück Piece		<table border="1"> <tr><td>BR</td><td></td></tr> <tr><td>AN</td><td></td></tr> <tr><td>KL</td><td></td></tr> <tr><td>GS</td><td></td></tr> <tr><td>Z</td><td>X</td></tr> <tr><td>W</td><td>X</td></tr> </table>	BR		AN		KL		GS		Z	X	W	X
BR																	
AN																	
KL																	
GS																	
Z	X																
W	X																
	<p>ACSIL08</p> <p>-Siliconenpomp -Pistolet doseur pour les tubes silicones -Handkartuschenpistole für die verarbeitung von silikonen und leime -Silicone gun</p>	1	Stuk Pièce Stück Piece		<table border="1"> <tr><td>BR</td><td></td></tr> <tr><td>AN</td><td></td></tr> <tr><td>KL</td><td></td></tr> <tr><td>GS</td><td></td></tr> <tr><td>Z</td><td></td></tr> <tr><td>W</td><td></td></tr> </table>	BR		AN		KL		GS		Z		W	
BR																	
AN																	
KL																	
GS																	
Z																	
W																	
	<p>ACSIL013</p> <p>-Lijm voor verstekhoek -Colle pour onglet -Kleber für gehrung -Glue for mitre</p>	1	Stuk Pièce Stück Piece		<table border="1"> <tr><td>BR</td><td></td></tr> <tr><td>AN</td><td></td></tr> <tr><td>KL</td><td></td></tr> <tr><td>GS</td><td></td></tr> <tr><td>Z</td><td></td></tr> <tr><td>W</td><td></td></tr> </table>	BR		AN		KL		GS		Z		W	
BR																	
AN																	
KL																	
GS																	
Z																	
W																	
	<p>ACSIL014</p> <p>-Anti-corro beschermingsproduct -Anti-corro produit de protection -Anti-corro schutzprodukt -Anti-corro protection product</p> <p>500ml</p>	1	Stuk Pièce Stück Piece		<table border="1"> <tr><td>BR</td><td></td></tr> <tr><td>AN</td><td></td></tr> <tr><td>KL</td><td></td></tr> <tr><td>GS</td><td></td></tr> <tr><td>Z</td><td></td></tr> <tr><td>W</td><td></td></tr> </table>	BR		AN		KL		GS		Z		W	
BR																	
AN																	
KL																	
GS																	
Z																	
W																	





BR = BRUT - BRUT - ROH - BRUT
 AN (X) = ANODISATIE - ANODISE - ELOXIERT - ANODISED
 AN (■) = GELAKT - LAQUE - LACKIERT - LACQUERED -- RAL9006M
 KL = STANDAARDKLEUREN - COULEUR STANDARD - BASIS FARBEN - BASIC COLORS
 GS = GEMOFFELD SPECIAAL - LAQUE SPECIAL - SPECIALFARBE - SPECIAL COLOR
 Z = ZWART - NOIR - SCHWARZ - BLACK
 W = WIT - BLANC - WEISS - WHITE

 GEREEDSCHAP - OUTILLAGE
 WERKZEUG - TOOL
 BEVESTIGING - FIXATION
 BEFESTIGUNG - FIXATION

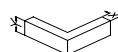



		Verp. per Emb. par Pack pr. Pack pr.	Einheid Unité Einheit Unit	Toepassing Application Anwendung Application	Kleur Couleur Farbe Color												
	<p>ACVG31</p> <p>-Beglazingsrubber buiten 3mm -Joint de vitrage extérieur 3mm -Glasanlage-Dichtung 3mm -Glazing gasket outside 3mm</p>	200	m	VN010 VN020 VN022 VN032 VN035	<table border="1"> <tr><td>BR</td><td></td></tr> <tr><td>AN</td><td></td></tr> <tr><td>KL</td><td></td></tr> <tr><td>GS</td><td></td></tr> <tr><td>Z</td><td></td></tr> <tr><td>W</td><td></td></tr> </table>	BR		AN		KL		GS		Z		W	
BR																	
AN																	
KL																	
GS																	
Z																	
W																	
	<p>ACUN020</p> <p>-Klembaar verstekhoekje -Equerre avec fonction -Eckverbindung mit sperrfunktion -Alignement corner with locking function</p>	10	Stuk Pièce Stück Pièce	VN010 VN161 VN164	<table border="1"> <tr><td>BR</td><td></td></tr> <tr><td>AN</td><td></td></tr> <tr><td>KL</td><td></td></tr> <tr><td>GS</td><td></td></tr> <tr><td>Z</td><td></td></tr> <tr><td>W</td><td></td></tr> </table>	BR		AN		KL		GS		Z		W	
BR																	
AN																	
KL																	
GS																	
Z																	
W																	
	<p>ACVG31N</p> <p>-Beglazingsrubber buiten 3mm ronddraaiend -Joint de vitrage extérieur 3mm tournant -Glasanlage-Dichtung 3mm herumdrehend -Glazing gasket outside 3mm rotated</p>	100	m	VN010 VN020 VN022 VN032 VN035	<table border="1"> <tr><td>BR</td><td></td></tr> <tr><td>AN</td><td></td></tr> <tr><td>KL</td><td></td></tr> <tr><td>GS</td><td></td></tr> <tr><td>Z</td><td></td></tr> <tr><td>W</td><td></td></tr> </table>	BR		AN		KL		GS		Z		W	
BR																	
AN																	
KL																	
GS																	
Z																	
W																	
	<p>ACVG32</p> <p>-Beglazingsrubber 3mm -Joint de vitrage 3mm -Glasdichtung 3mm -Glazing gasket 3mm</p>	100	m	VN161 VN162 VN164	<table border="1"> <tr><td>BR</td><td></td></tr> <tr><td>AN</td><td></td></tr> <tr><td>KL</td><td></td></tr> <tr><td>GS</td><td></td></tr> <tr><td>Z</td><td></td></tr> <tr><td>W</td><td></td></tr> </table>	BR		AN		KL		GS		Z		W	
BR																	
AN																	
KL																	
GS																	
Z																	
W																	
	<p>ACVG32N</p> <p>-Beglazingsrubber 3mm ronddraaiend -Joint de vitrage 3mm tournant -Glasdichtung 3mm herumdrehend -Glazing gasket 3mm rotated</p>	100	m	VN161 VN162 VN164	<table border="1"> <tr><td>BR</td><td></td></tr> <tr><td>AN</td><td></td></tr> <tr><td>KL</td><td></td></tr> <tr><td>GS</td><td></td></tr> <tr><td>Z</td><td></td></tr> <tr><td>W</td><td></td></tr> </table>	BR		AN		KL		GS		Z		W	
BR																	
AN																	
KL																	
GS																	
Z																	
W																	







		Verp. per Emb. par Pack pr. Pack pr.	Eenheid Unité Einheit Unit	Toepassing Application Anwendung Application	Kleur Couleur Farbe Color												
	ACVG33 -Beglazingsrubber 4mm -Joint de vitrage 4mm -Glasdichtung 4mm -Glazing gasket 4mm	100	m	VN161 VN162 VN164	<table border="1"> <tr><td>BR</td><td></td></tr> <tr><td>AN</td><td></td></tr> <tr><td>KL</td><td></td></tr> <tr><td>GS</td><td></td></tr> <tr><td>Z</td><td></td></tr> <tr><td>W</td><td></td></tr> </table>	BR		AN		KL		GS		Z		W	
BR																	
AN																	
KL																	
GS																	
Z																	
W																	
	ACVG33N -Beglazingsrubber 4mm ronddraaiend -Joint de vitrage 4mm tournant -Glasdichtung 4mm herumdrehend -Glazing gasket 4mm rotated	100	m	VN161 VN162 VN164	<table border="1"> <tr><td>BR</td><td></td></tr> <tr><td>AN</td><td></td></tr> <tr><td>KL</td><td></td></tr> <tr><td>GS</td><td></td></tr> <tr><td>Z</td><td></td></tr> <tr><td>W</td><td></td></tr> </table>	BR		AN		KL		GS		Z		W	
BR																	
AN																	
KL																	
GS																	
Z																	
W																	
	ACVG34 -Beglazingsrubber 5mm -Joint de vitrage 5mm -Glasdichtung 5mm -Glazing gasket 5mm	200	m	VN161 VN162 VN164	<table border="1"> <tr><td>BR</td><td></td></tr> <tr><td>AN</td><td></td></tr> <tr><td>KL</td><td></td></tr> <tr><td>GS</td><td></td></tr> <tr><td>Z</td><td></td></tr> <tr><td>W</td><td></td></tr> </table>	BR		AN		KL		GS		Z		W	
BR																	
AN																	
KL																	
GS																	
Z																	
W																	
	ACVG34N -Beglazingsrubber 5mm ronddraaiend -Joint de vitrage 5mm tournant -Glasdichtung 5mm herumdrehend -Glazing gasket 5mm rotated	100	m	VN161 VN162 VN164	<table border="1"> <tr><td>BR</td><td></td></tr> <tr><td>AN</td><td></td></tr> <tr><td>KL</td><td></td></tr> <tr><td>GS</td><td></td></tr> <tr><td>Z</td><td></td></tr> <tr><td>W</td><td></td></tr> </table>	BR		AN		KL		GS		Z		W	
BR																	
AN																	
KL																	
GS																	
Z																	
W																	
	ACVG45 -Afdekkapje waterafvoer -Capuchon écoulement d'eau -Abdeckkappe entwässerung -Drain hole cover	1	Stuk Pièce Stück Piece	VN010	<table border="1"> <tr><td>BR</td><td></td></tr> <tr><td>AN</td><td></td></tr> <tr><td>KL</td><td>X</td></tr> <tr><td>GS</td><td></td></tr> <tr><td>Z</td><td>X</td></tr> <tr><td>W</td><td>X</td></tr> </table>	BR		AN		KL	X	GS		Z	X	W	X
BR																	
AN																	
KL	X																
GS																	
Z	X																
W	X																

BR = BRUT - BRUT - ROH - BRUT
 AN (X) = ANODISATIE - ANODISE - ELOXIERT - ANODISED
 AN (■) = GELAKT - LAQUE - LACKIERT - LACQUERED -- RAL9006M
 KL = STANDAARDKLEUREN - COULEUR STANDARD - BASIS FARBEN - BASIC COLORS
 GS = GEMOFFELD SPECIAAL - LAQUE SPECIAL - SPECIALFARBE - SPECIAL COLOR
 Z = ZWART - NOIR - SCHWARZ - BLACK
 W = WIT - BLANC - WEISS - WHITE

 GEREEDSCHAP - OUTILLAGE
 WERKZEUG - TOOL
 BEVESTIGING - FIXATION
 BEFESTIGUNG - FIXATION



		Verp. per Emb. par Pack pr.	Einheid Unité Einheit Unit	Toepassing Application Anwendung Application	Kleur Couleur Farbe Color												
	ACVG65 -Zeskantsleutel 2.5mm -Clé à six pans 2.5mm -Sechskantschlüssel 2.5mm -T-handle hexagon-key 2.5mm	1	Stuk Pièce Stück Piece		<table border="1"> <tr><td>BR</td><td></td></tr> <tr><td>AN</td><td></td></tr> <tr><td>KL</td><td></td></tr> <tr><td>GS</td><td></td></tr> <tr><td>Z</td><td></td></tr> <tr><td>W</td><td></td></tr> </table>	BR		AN		KL		GS		Z		W	
BR																	
AN																	
KL																	
GS																	
Z																	
W																	
	ACVG66 -Zeskantsleutel 3mm -Clé à six pans 3mm -Sechskantschlüssel 3mm -T-handle hexagon-key 3mm	1	Stuk Pièce Stück Piece		<table border="1"> <tr><td>BR</td><td></td></tr> <tr><td>AN</td><td></td></tr> <tr><td>KL</td><td></td></tr> <tr><td>GS</td><td></td></tr> <tr><td>Z</td><td></td></tr> <tr><td>W</td><td></td></tr> </table>	BR		AN		KL		GS		Z		W	
BR																	
AN																	
KL																	
GS																	
Z																	
W																	
	ACVG131 -Beglazingsrubber buiten 4mm -Joint de vitrage extérieur 4mm -Glasanlage-Dichtung 4mm -Glazing gasket outside 4mm	100	m	VN010 VN020 VN022 VN032 VN035	<table border="1"> <tr><td>BR</td><td></td></tr> <tr><td>AN</td><td></td></tr> <tr><td>KL</td><td></td></tr> <tr><td>GS</td><td></td></tr> <tr><td>Z</td><td></td></tr> <tr><td>W</td><td></td></tr> </table>	BR		AN		KL		GS		Z		W	
BR																	
AN																	
KL																	
GS																	
Z																	
W																	
	ACVG131N -Beglazingsrubber buiten 4mm ronddraaiend -Joint de vitrage extérieur 4mm tournant -Glasanlage-Dichtung 4mm herumdrehend -Glazing gasket outside 4mm rotated	100	m	VN010 VN020 VN022 VN032 VN035	<table border="1"> <tr><td>BR</td><td></td></tr> <tr><td>AN</td><td></td></tr> <tr><td>KL</td><td></td></tr> <tr><td>GS</td><td></td></tr> <tr><td>Z</td><td></td></tr> <tr><td>W</td><td></td></tr> </table>	BR		AN		KL		GS		Z		W	
BR																	
AN																	
KL																	
GS																	
Z																	
W																	
	ACVG231 -Beglazingsrubber buiten 2mm -Joint de vitrage extérieur 2mm -Glasanlage-Dichtung 2mm -Glazing gasket outside 2mm	200	m	VN010 VN020 VN022 VN032 VN035	<table border="1"> <tr><td>BR</td><td></td></tr> <tr><td>AN</td><td></td></tr> <tr><td>KL</td><td></td></tr> <tr><td>GS</td><td></td></tr> <tr><td>Z</td><td></td></tr> <tr><td>W</td><td></td></tr> </table>	BR		AN		KL		GS		Z		W	
BR																	
AN																	
KL																	
GS																	
Z																	
W																	

BR = BRUT - BRUT - ROH - BRUT
 AN (X) = ANODISATIE - ANODISE - ELOXIERT - ANODISED
 AN (■) = GELAKT - LAQUE - LACKIERT - LACQUERED -- RAL9006M
 KL = STANDAARDKLEUREN - COULEUR STANDARD - BASIS FARBEN - BASIC COLORS
 GS = GEMOFFELD SPECIAAL - LAQUE SPECIAL - SPECIALFARBE - SPECIAL COLOR
 Z = ZWART - NOIR - SCHWARZ - BLACK
 W = WIT - BLANC - WEISS - WHITE







GEREEDSCHAP - OUTILLAGE
WERKZEUG - TOOL

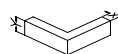

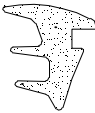

BEVESTIGING - FIXATION
BEFESTIGUNG - FIXATION





		Verp. per Emb. par Pack pr. Pack pr.	Eenheid Unité Einheit Unit	Toepassing Application Anwendung Application	Kleur Couleur Farbe Color
	ACVG231N -Beglazingsrubber buiten 2mm ronddraaiend -Joint de vitrage extérieur 2mm tournant -Glasanlage-Dichtung 2mm herumdrehend -Glazing gasket outside 2mm rotated	100	m	VN010 VN020 VN022 VN032 VN035	BR AN KL GS Z W
	ACVG340 -Beglazingsrubber 6mm -Joint de vitrage 6mm -Glasdichtung 6mm -Glazing gasket 6mm	200	m	VN161 VN162 VN164	BR AN KL GS Z W
	ACVG340N -Beglazingsrubber 6mm ronddraaiend -Joint de vitrage 6mm tournant -Glasdichtung 6mm herumdrehend -Glazing gasket 6mm rotated	100	m	VN161 VN162 VN164	BR AN KL GS Z W
	ACVL020 -Verstekhoekje in inox -Equerre de jonction -Eckverstärkung -Framing square	1	Stuk Pièce Stück Piece	VN010 VN161 VN164	BR AN KL GS Z W
	ACVL020B -Verstekhoekje in kunststof -Equerre de jonction en plastique -Eckverstärkung in plastik -Framing square in plastic	1	Stuk Pièce Stück Piece	VN010 VN161 VN164	BR AN KL GS Z W

BR = BRUT - BRUT - ROH - BRUT
 AN (X) = ANODISATIE - ANODISE - ELOXIERT - ANODISED
 AN (■) = GELAKT - LAQUE - LACKIERT - LACQUERED -- RAL9006M
 KL = STANDAARDKLEUREN - COULEUR STANDARD - BASIS FARBEN - BASIC COLORS
 GS = GEMOFFELD SPECIAAL - LAQUE SPECIAL - SPECIALFARBE - SPECIAL COLOR
 Z = ZWART - NOIR - SCHWARZ - BLACK
 W = WIT - BLANC - WEISS - WHITE

 GEREEDSCHAP - OUTILLAGE
 WERKZEUG - TOOL
 BEVESTIGING - FIXATION
 BEFESTIGUNG - FIXATION



		Verp. per Emb. par Pack pr.	Einheid Unité Einheit Unit	Toepassing Application Anwendung Application	Kleur Couleur Farbe Color												
	ACVL029 -Verstevigingsstukje -Pièce de renforcement -Verstärkungsstück -Renforcement piece	1	Stuk Pièce Stück Piece	VN032 VN035	<table border="1"> <tr><td>BR</td><td></td></tr> <tr><td>AN</td><td></td></tr> <tr><td>KL</td><td></td></tr> <tr><td>GS</td><td></td></tr> <tr><td>Z</td><td></td></tr> <tr><td>W</td><td></td></tr> </table>	BR		AN		KL		GS		Z		W	
BR																	
AN																	
KL																	
GS																	
Z																	
W																	
	ACVL031 -Aanslagdichting ramen -Joint pour fenêtres -Flügeldichtung Rahmen -Gasket for windows	100	m	VN020 VN022 VN161 VN164	<table border="1"> <tr><td>BR</td><td></td></tr> <tr><td>AN</td><td></td></tr> <tr><td>KL</td><td></td></tr> <tr><td>GS</td><td></td></tr> <tr><td>Z</td><td></td></tr> <tr><td>W</td><td></td></tr> </table>	BR		AN		KL		GS		Z		W	
BR																	
AN																	
KL																	
GS																	
Z																	
W																	
	ACVL031N -Aanslagdichting ramen ronddraaiend -Joint pour fenêtres tournant -Flügeldichtung Rahmen herumdrehend -Gasket for windows rotated	100	m	VN020 VN022 VN161 VN164	<table border="1"> <tr><td>BR</td><td></td></tr> <tr><td>AN</td><td></td></tr> <tr><td>KL</td><td></td></tr> <tr><td>GS</td><td></td></tr> <tr><td>Z</td><td></td></tr> <tr><td>W</td><td></td></tr> </table>	BR		AN		KL		GS		Z		W	
BR																	
AN																	
KL																	
GS																	
Z																	
W																	

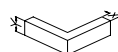

RAMEN
FENETRES
RAHMEN
WINDOWS

DOORSNEDE - COUPE - SCHNITT - SECTION

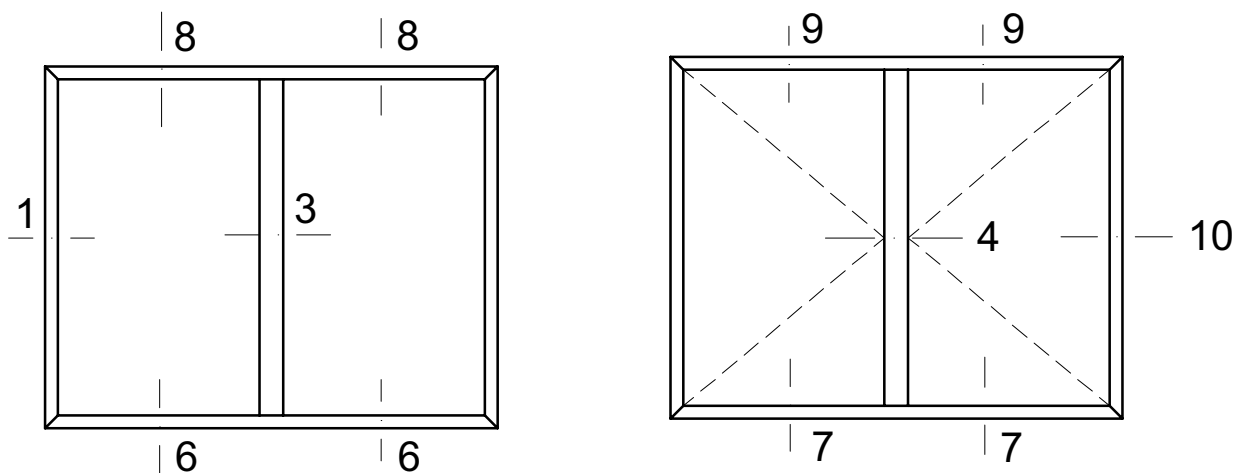
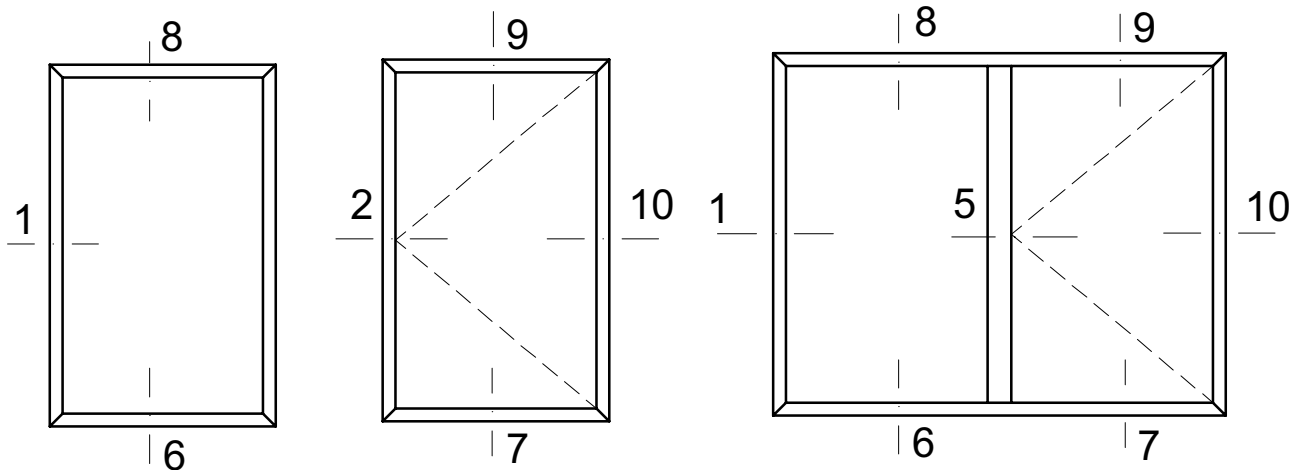

MAX VLEUGELAFMETING B = 1200mm
 MAX DIMENSIONS DU VANTAIL H = 1650mm
 MAX AUSDEHNUNG DER FLÜGEL
 MAX DIMENSION OF THE CASEMENT

overzicht

1A

DOORSNEDE - COUPE - SCHNITT - SECTION

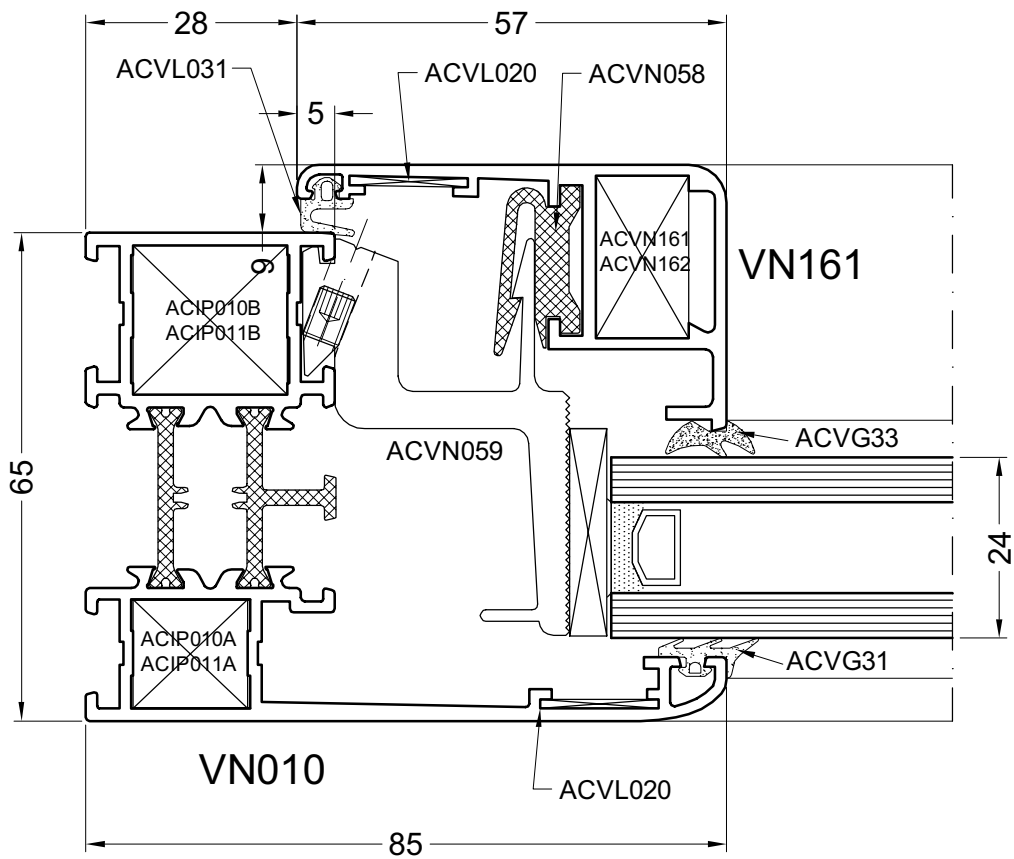
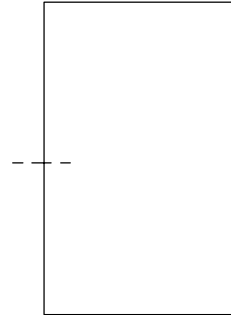

doorvn1a

1B

DOORSNEDE - COUPE - SCHNITT - SECTION

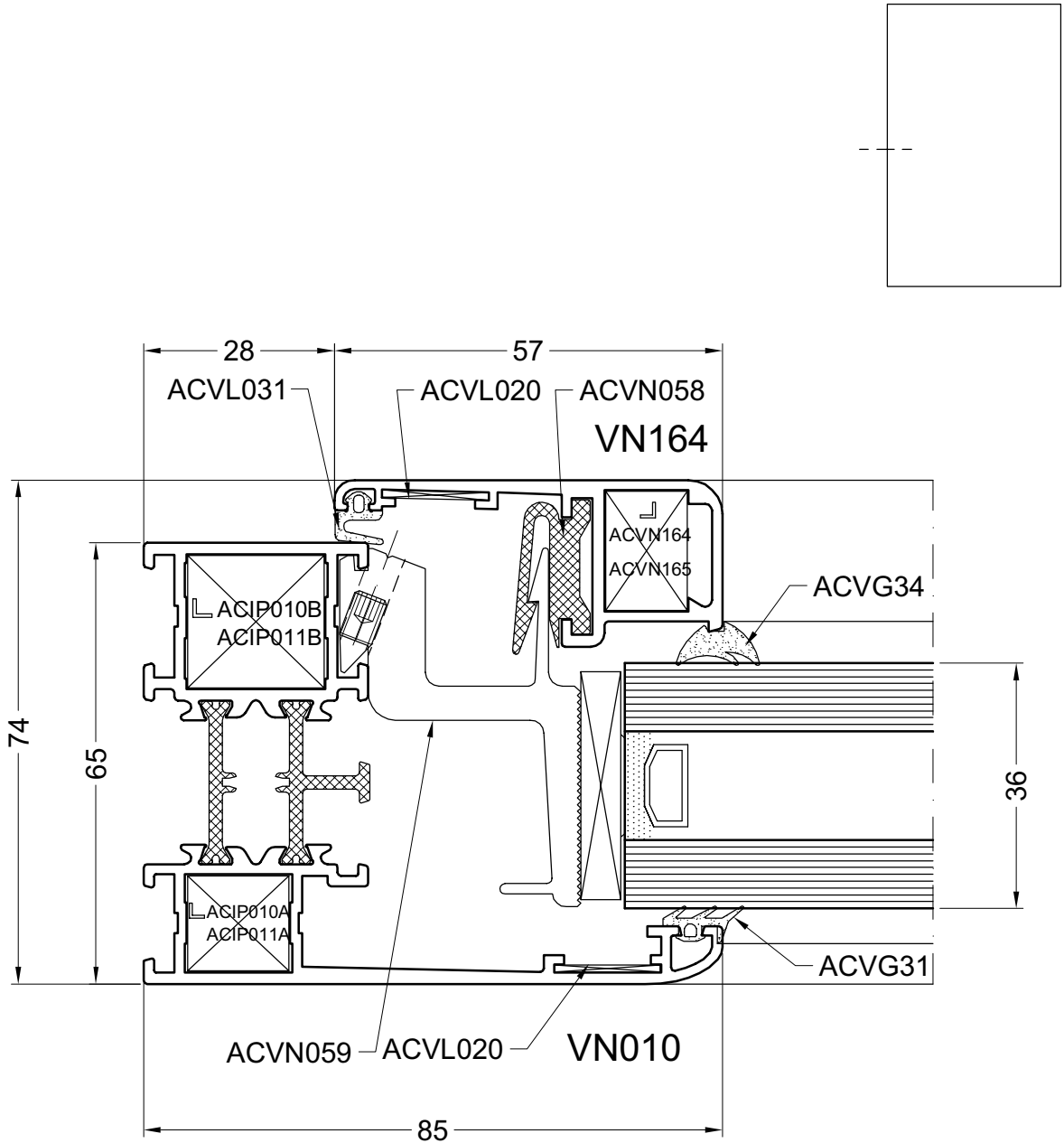

doorvn1b

2A

DOORSNEDE - COUPE - SCHNITT - SECTION

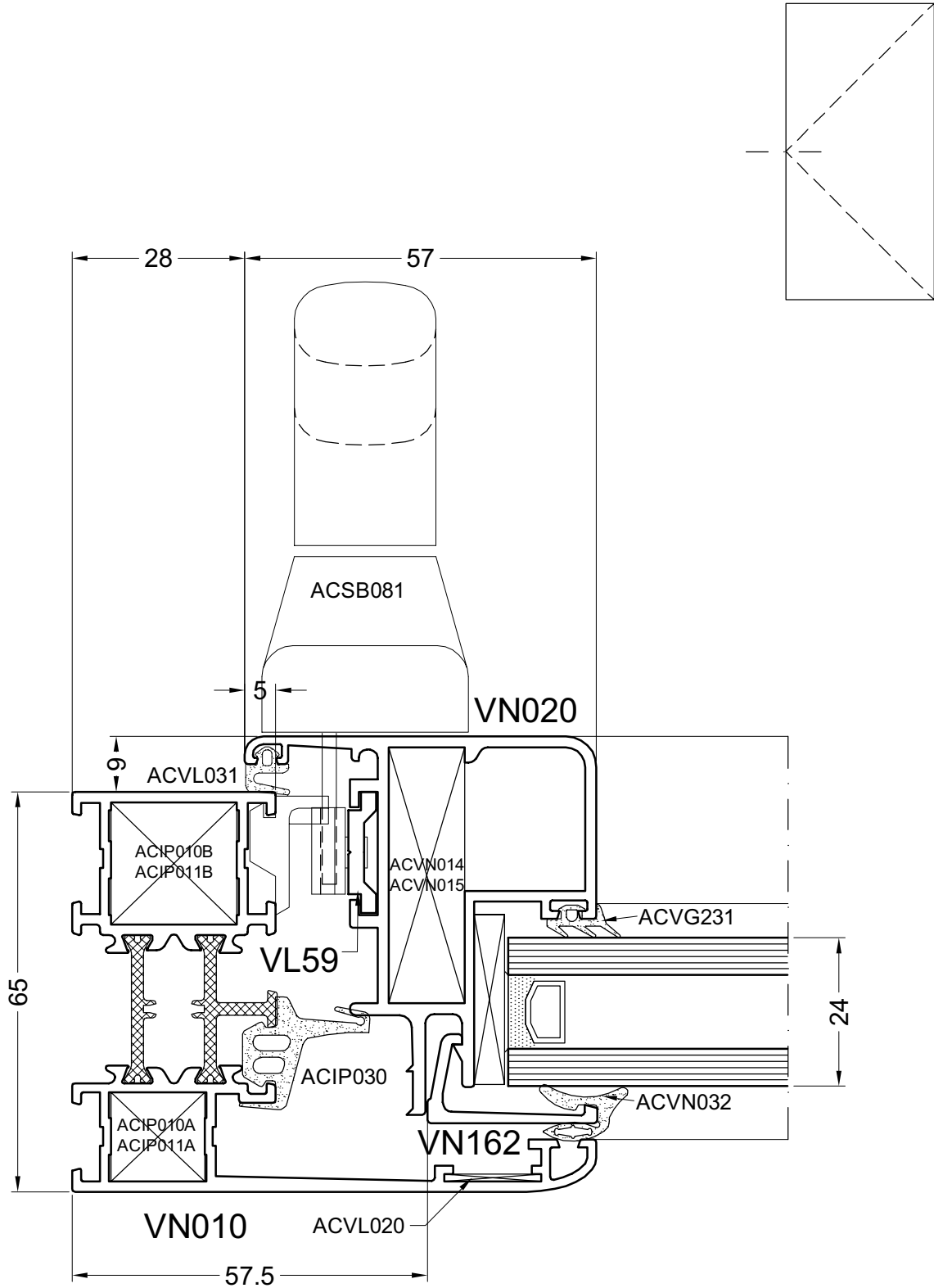

doorvn2a

2B

DOORSNEDE - COUPE - SCHNITT - SECTION

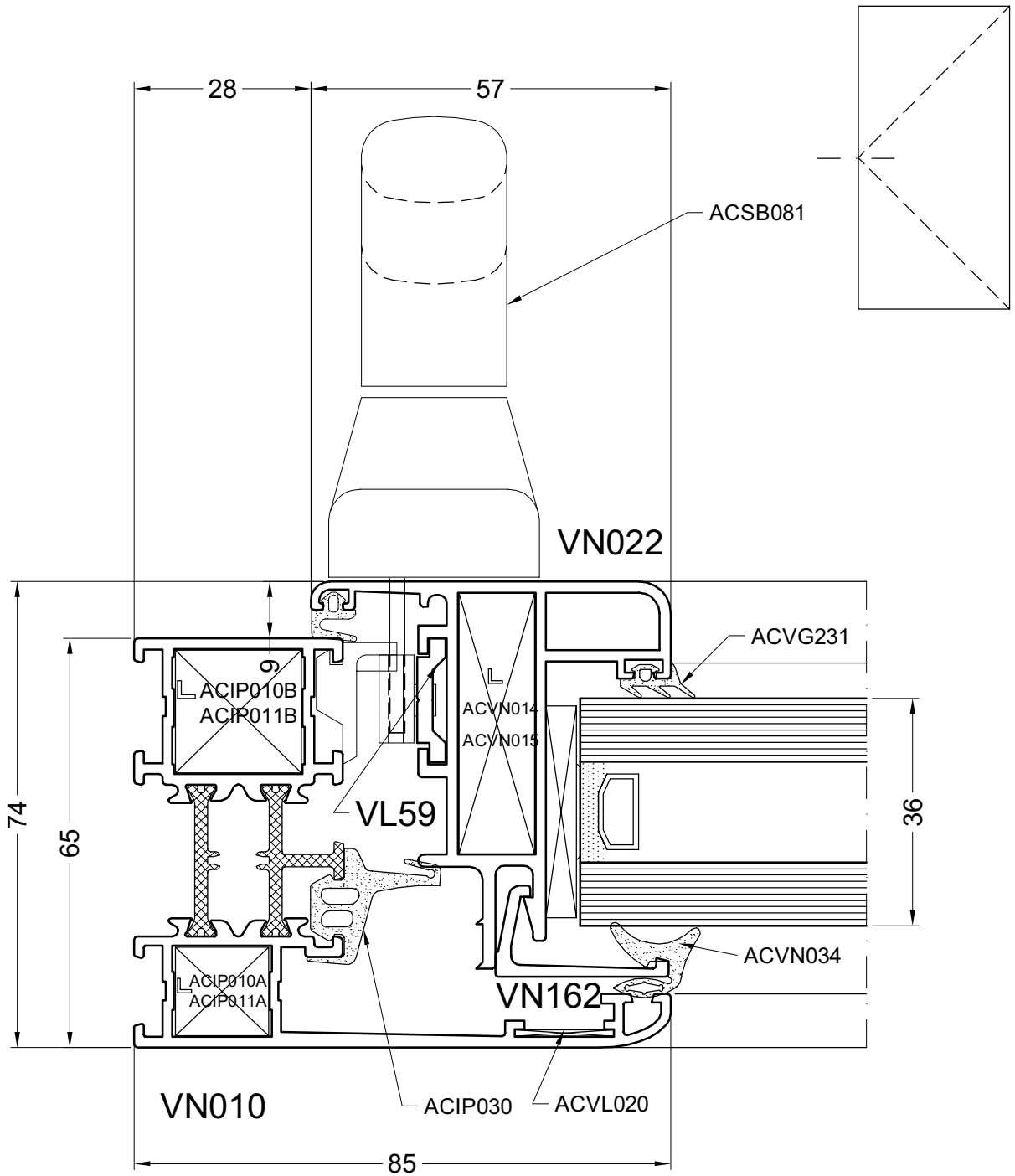

doorvn2c

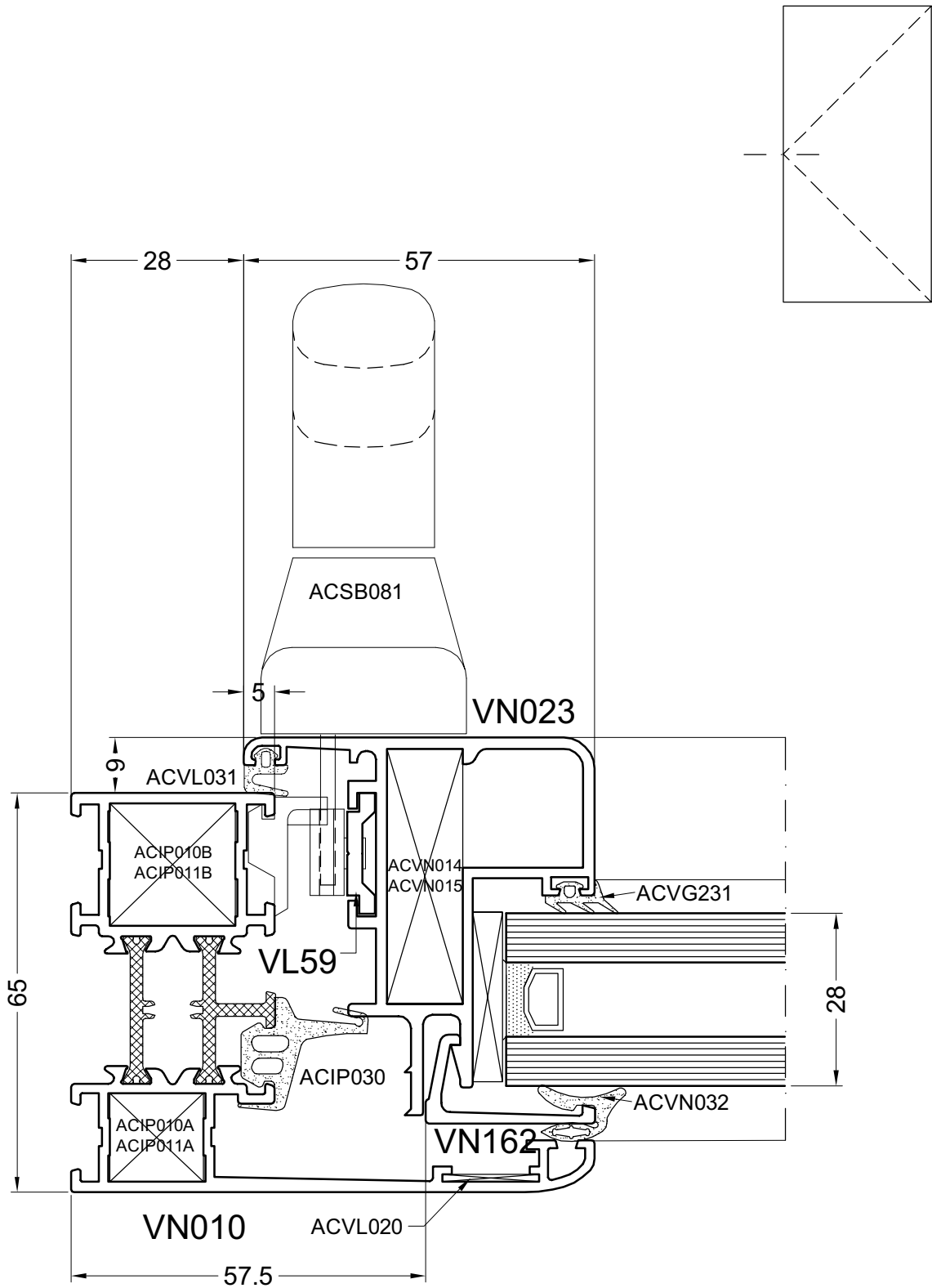

doorvn2d

2D

DOORSNEDE - COUPE - SCHNITT - SECTION

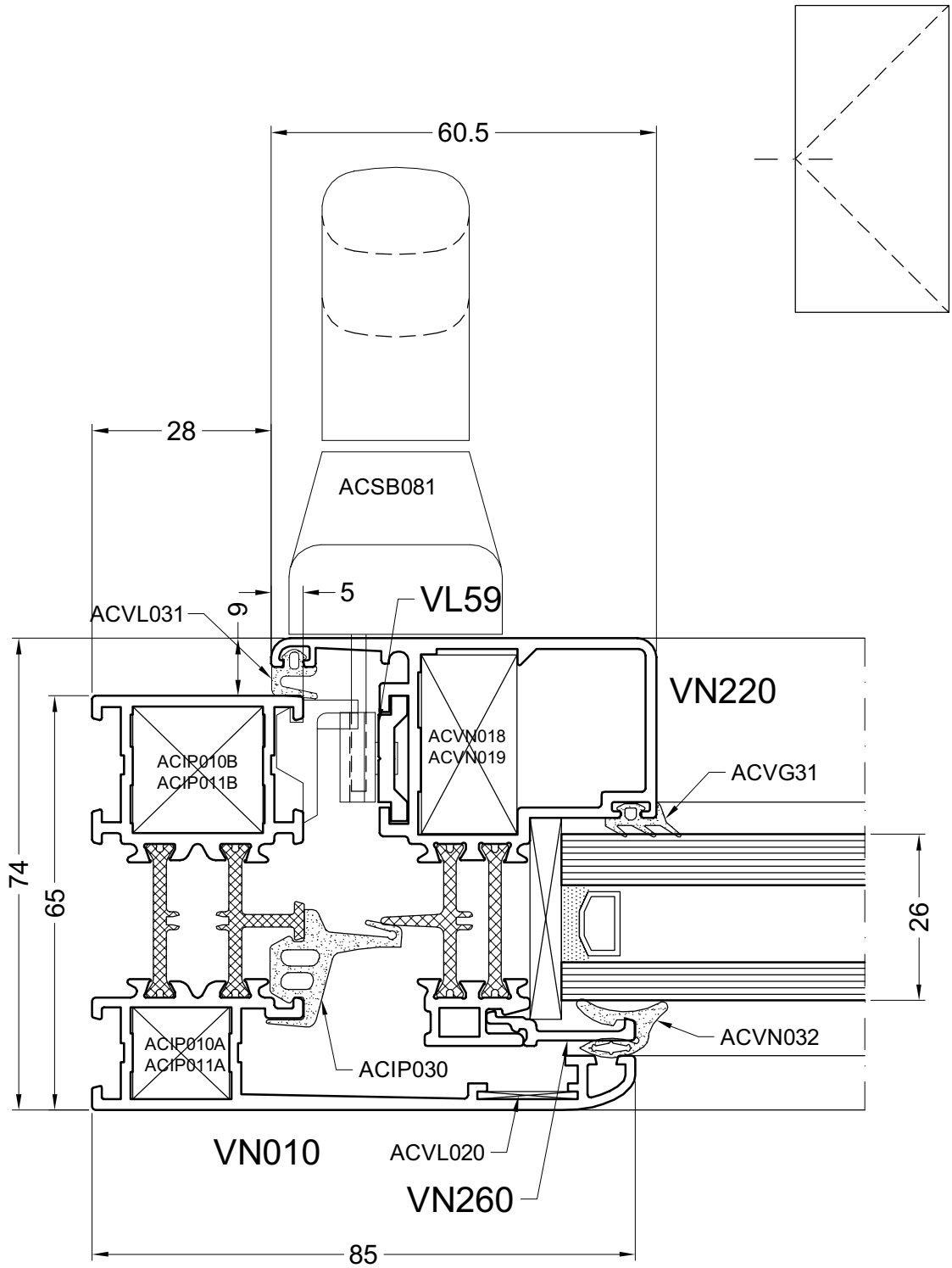

doorvn2e

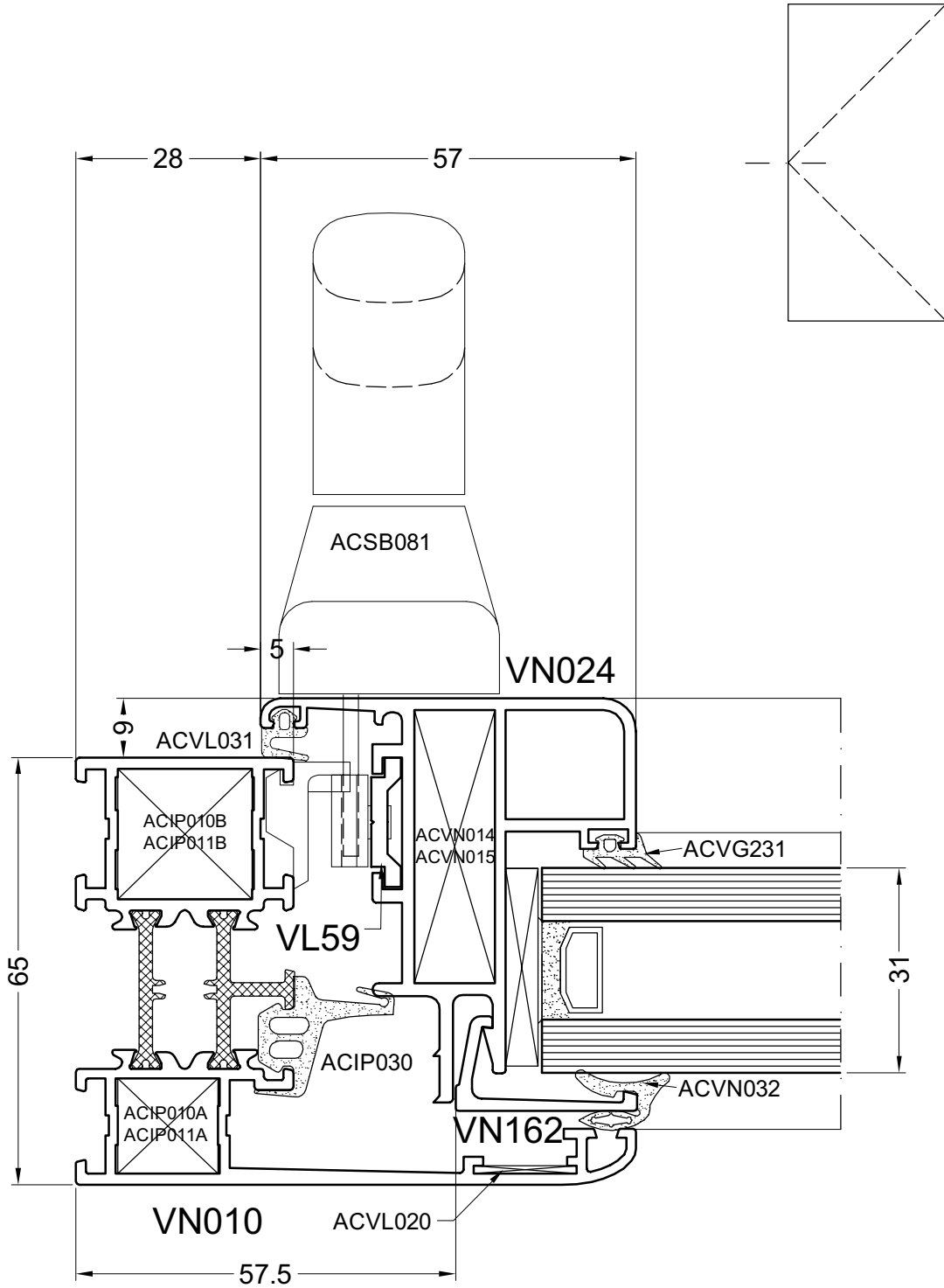

doorvn2f

3A

DOORSNEDE - COUPE - SCHNITT - SECTION

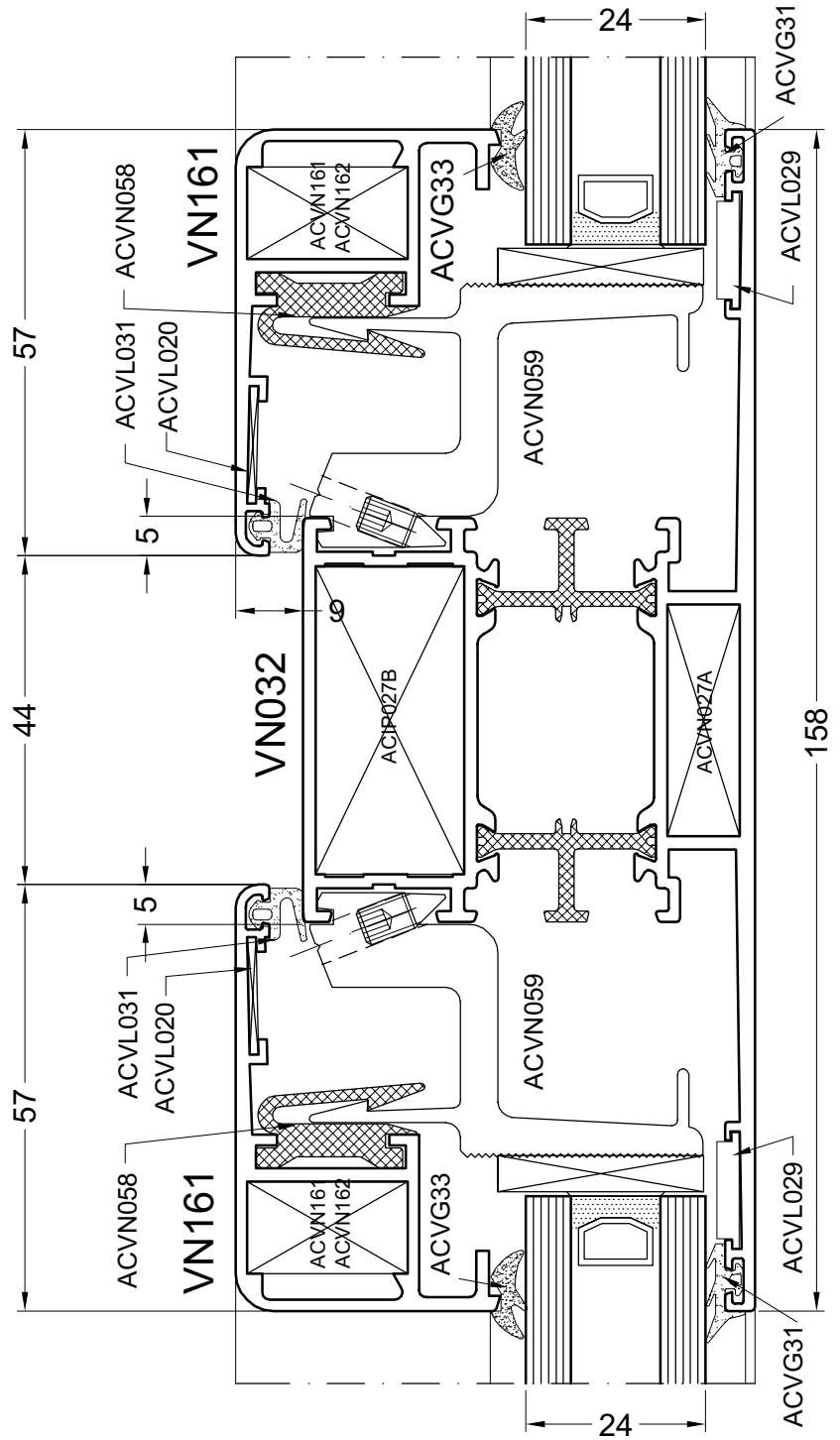
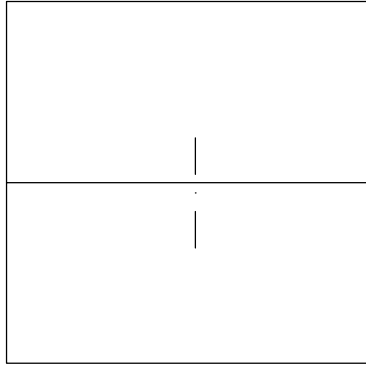

doorvn3a

3B

DOORSNEDE - COUPE - SCHNITT - SECTION

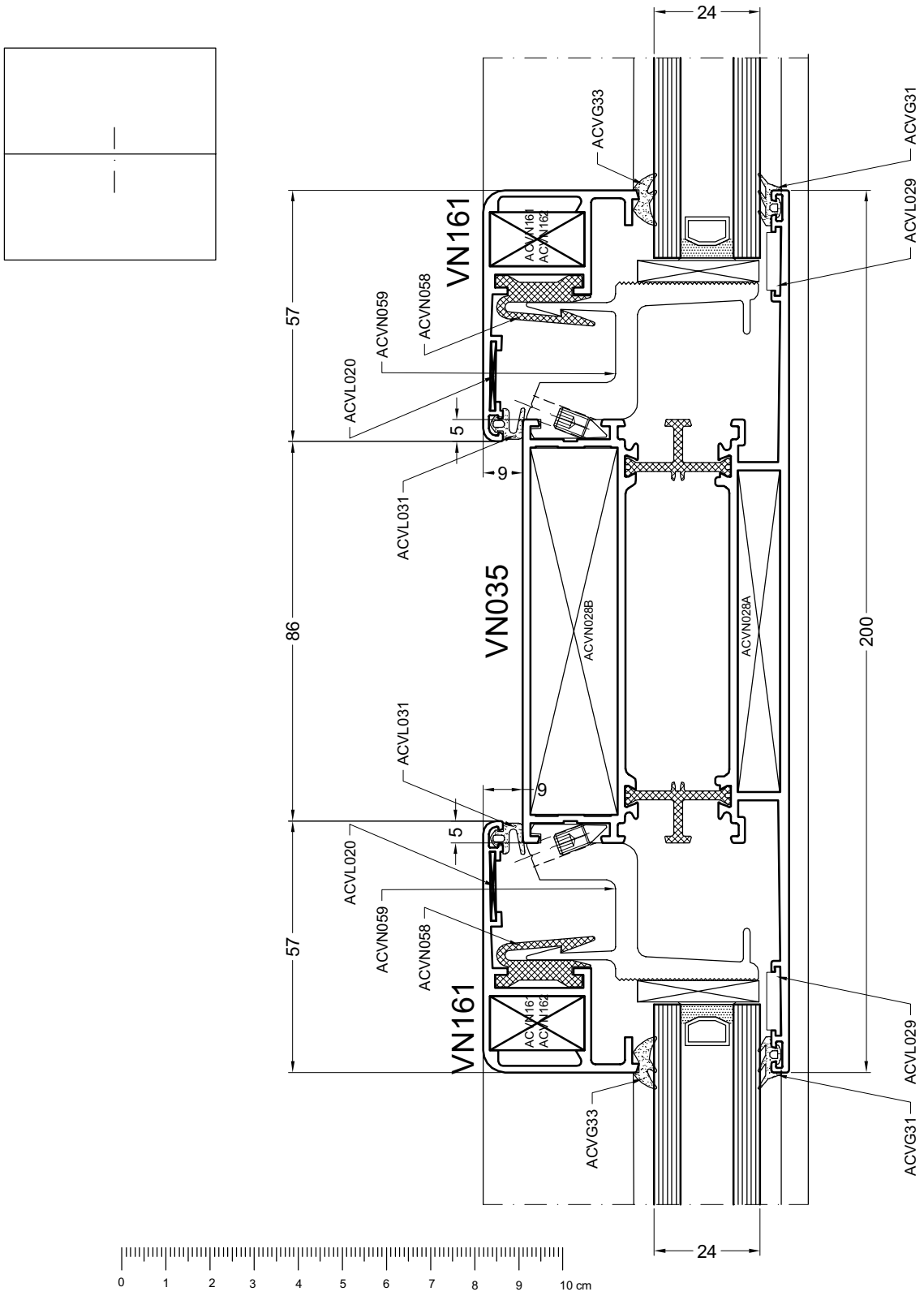

doorvn3b

3C

DOORSNEDE - COUPE - SCHNITT - SECTION

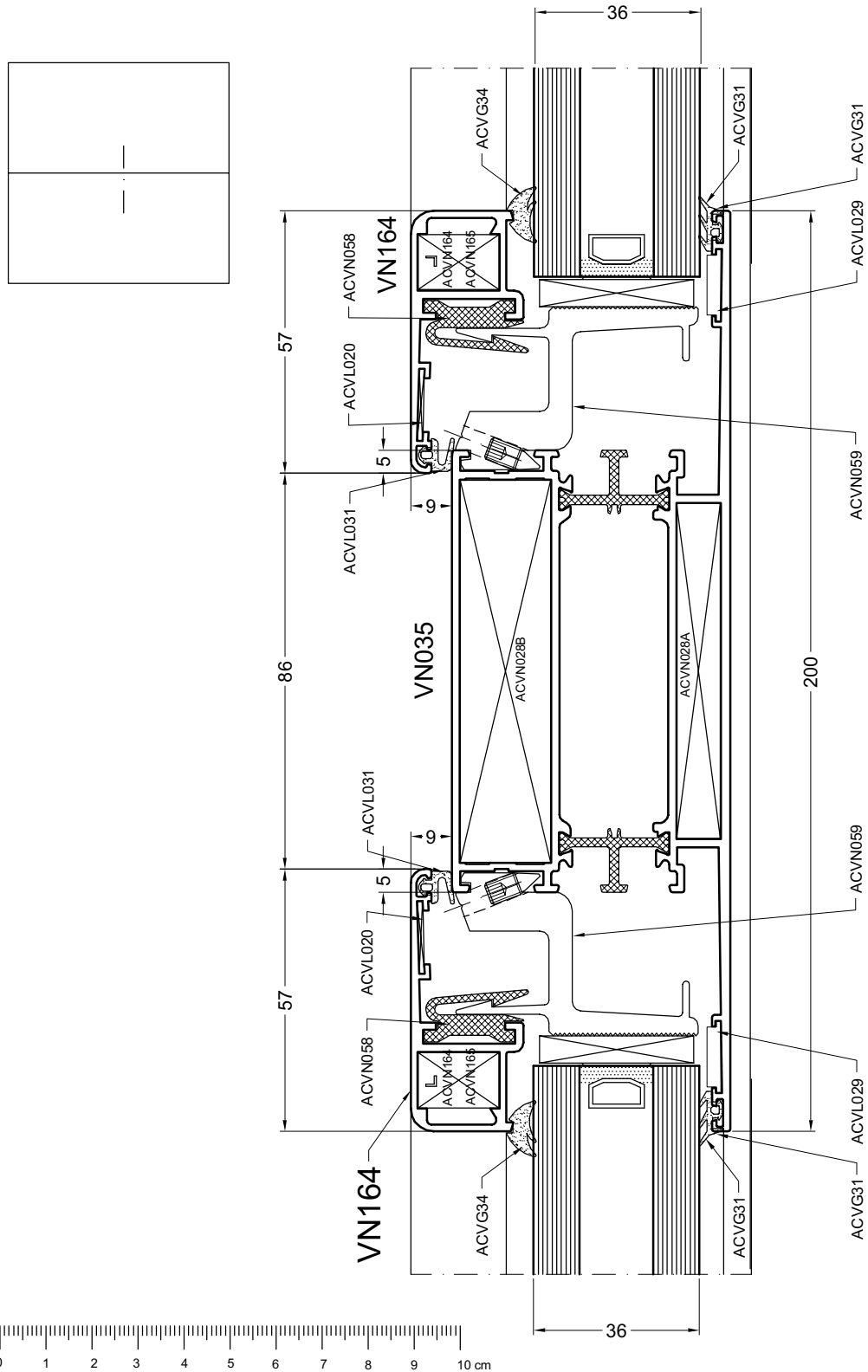

doorvn3c

4A

DOORSNEDE - COUPE - SCHNITT - SECTION

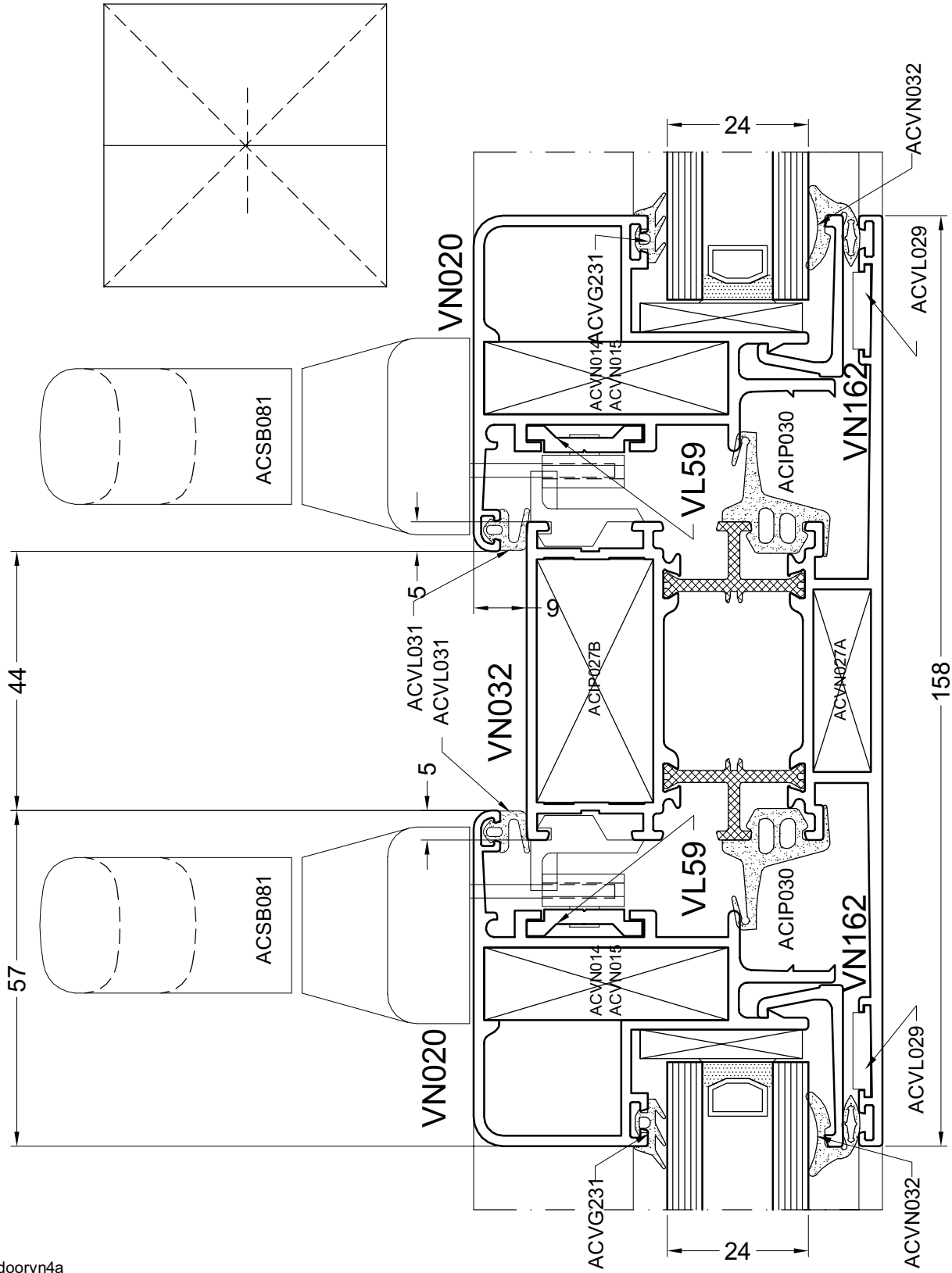

doorvn4a

4B

DOORSNEDE - COUPE - SCHNITT - SECTION

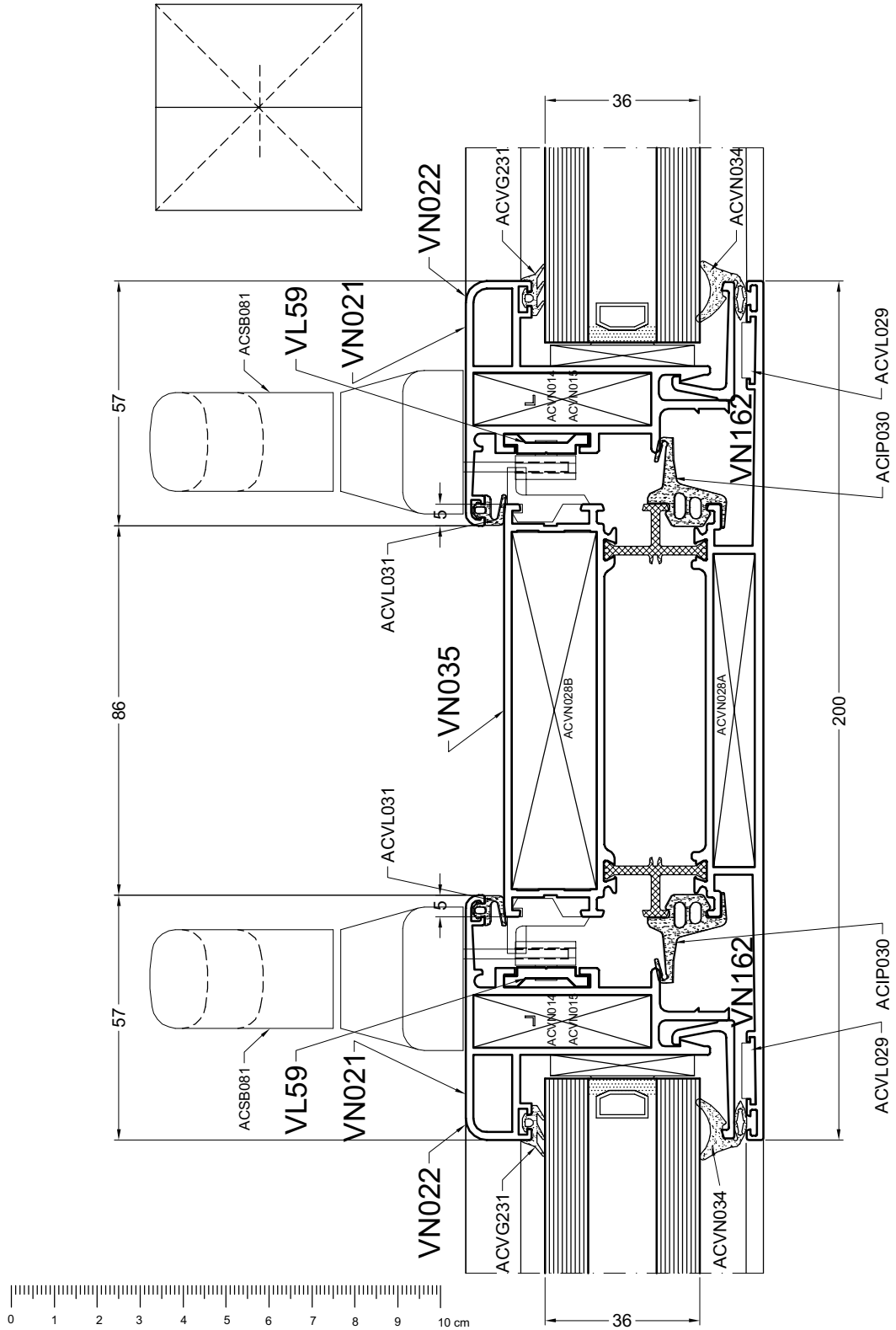

doorvn4c

5A

DOORSNEDE - COUPE - SCHNITT - SECTION

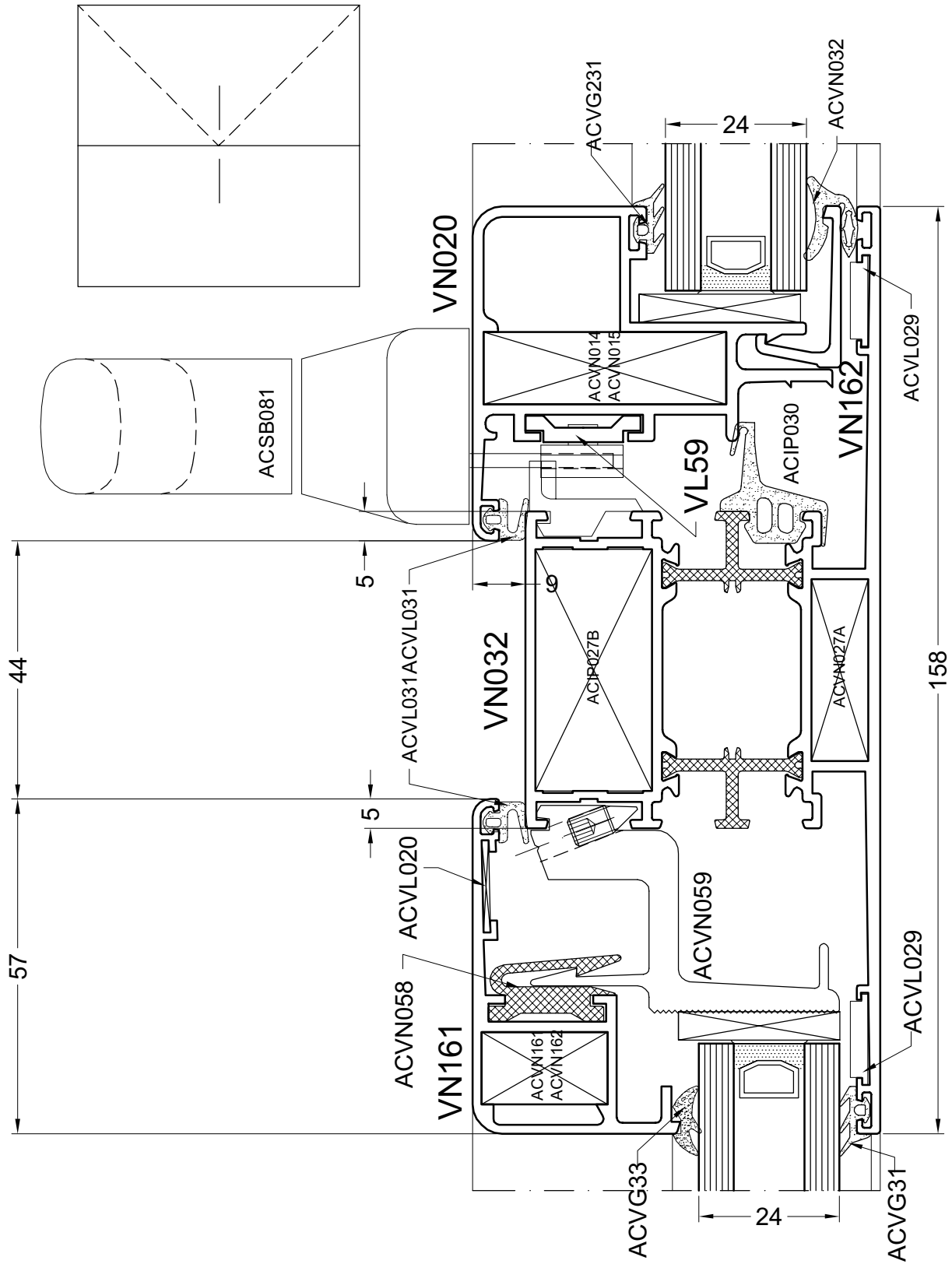

doorvn5a

6A

DOORSNEDE - COUPE - SCHNITT - SECTION

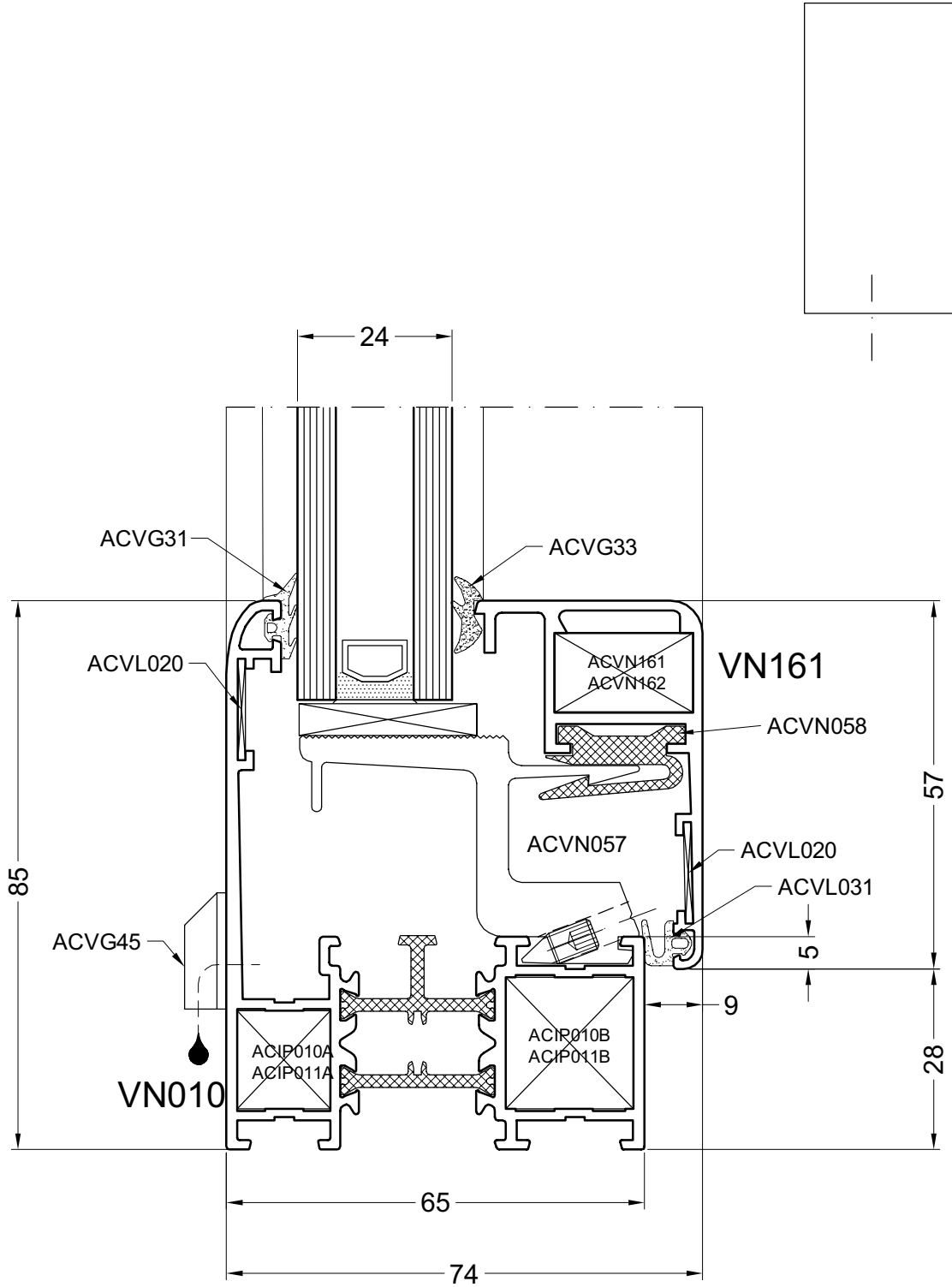

doorvn6a

6B

DOORSNEDE - COUPE - SCHNITT - SECTION

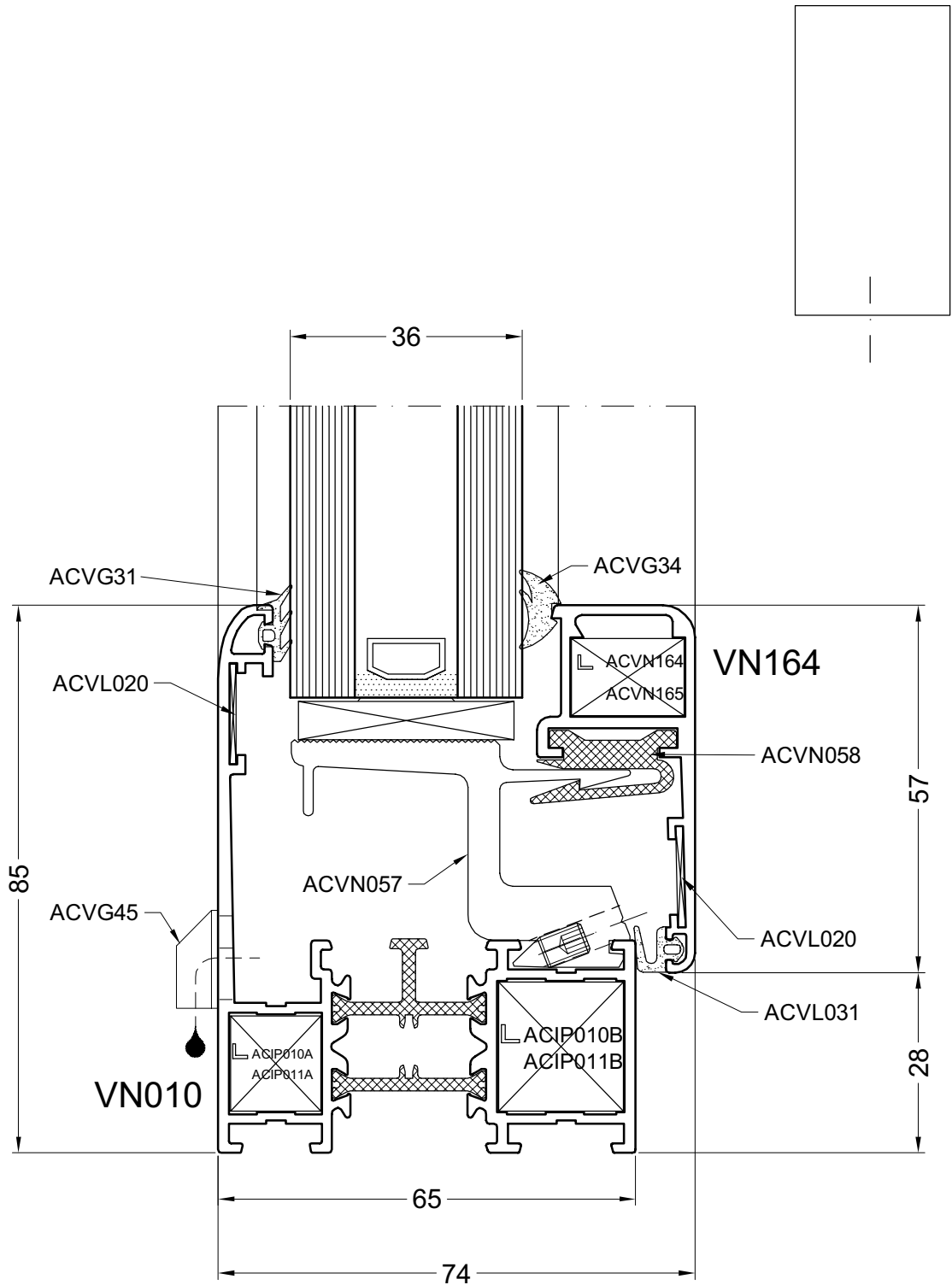

doorvn6b

7A

DOORSNEDE - COUPE - SCHNITT - SECTION

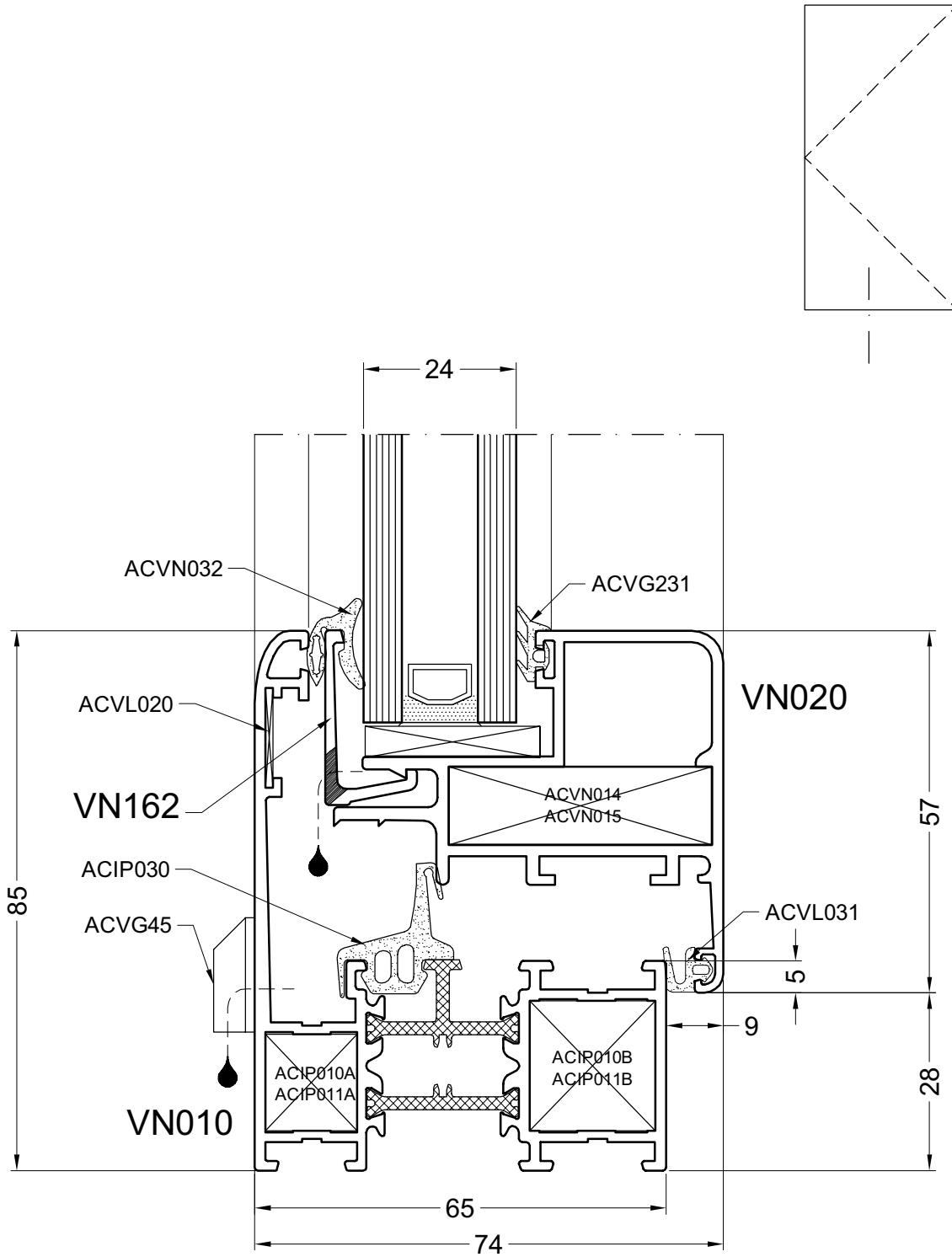

doorvn7a

7B

DOORSNEDE - COUPE - SCHNITT - SECTION

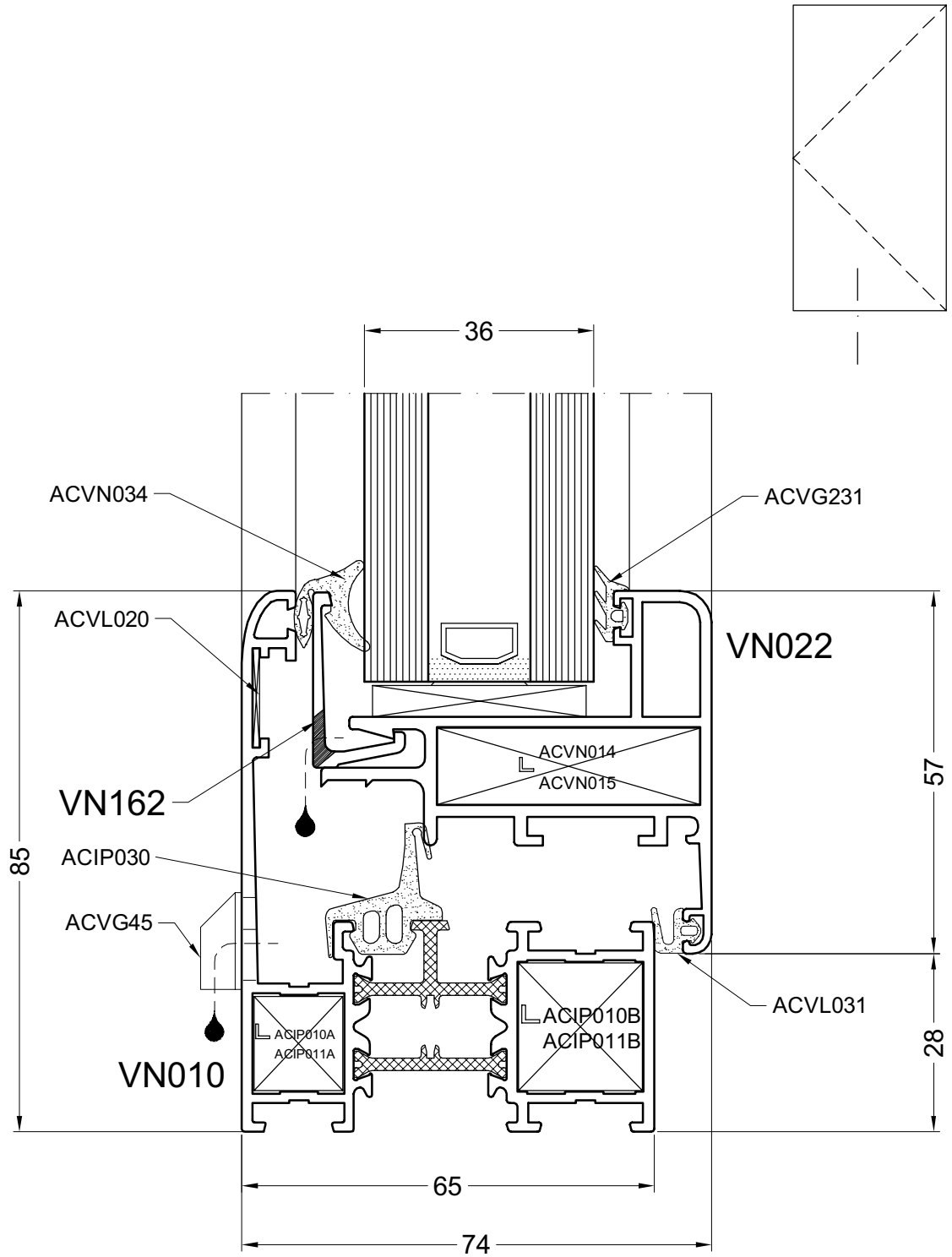

doorvn7c

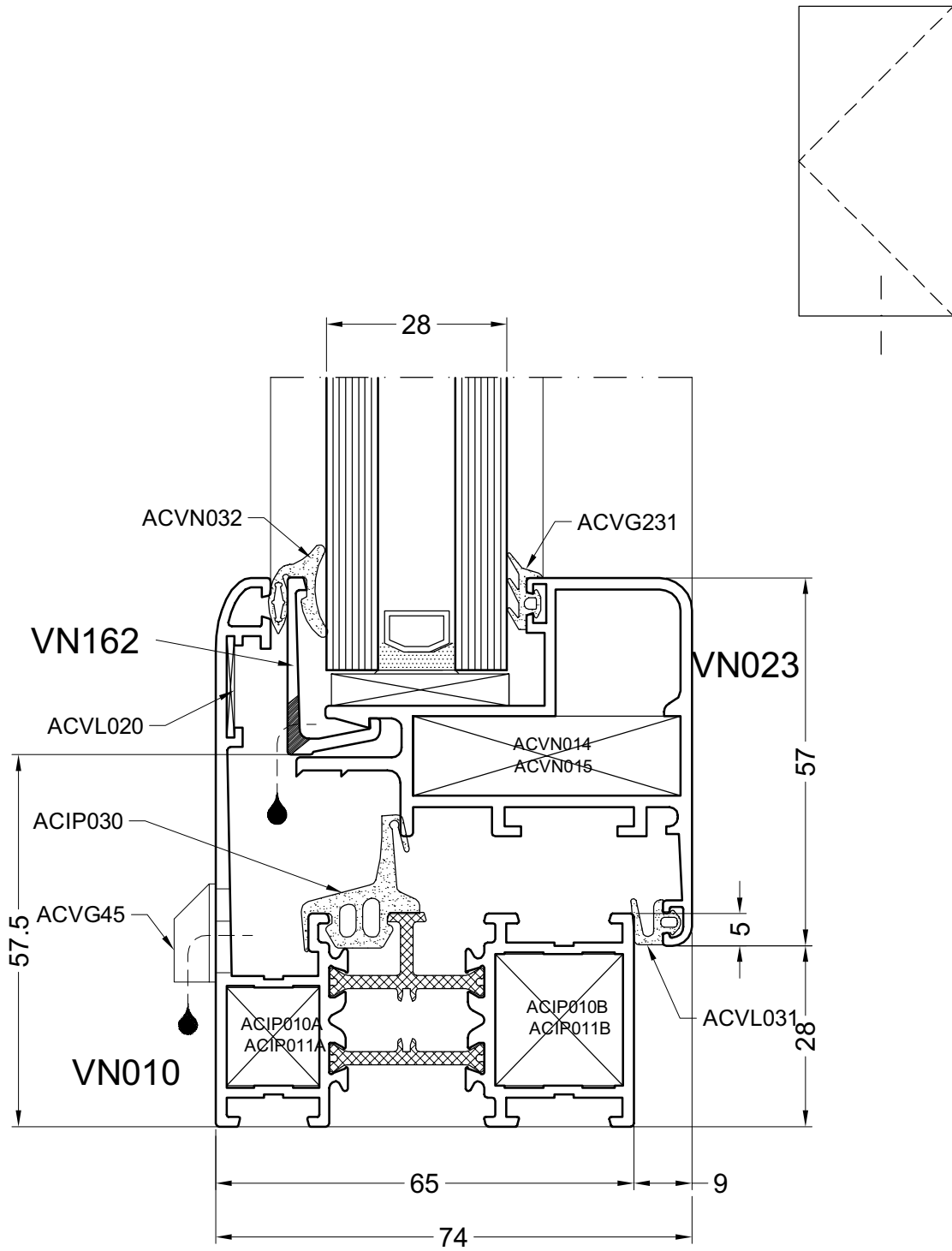

doorvn7d

7D

DOORSNEDE - COUPE - SCHNITT - SECTION

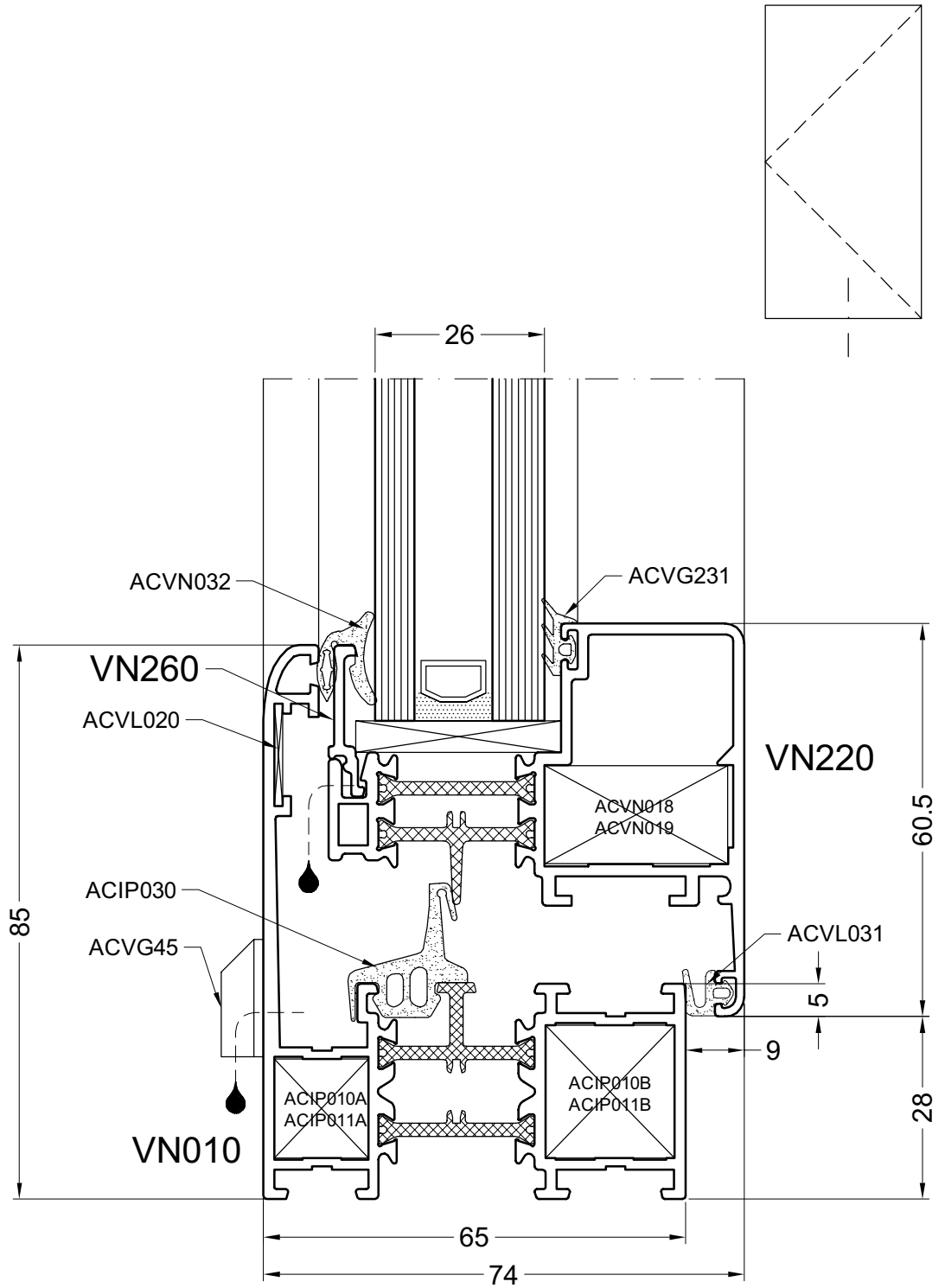

doorvn7e

8A

DOORSNEDE - COUPE - SCHNITT - SECTION

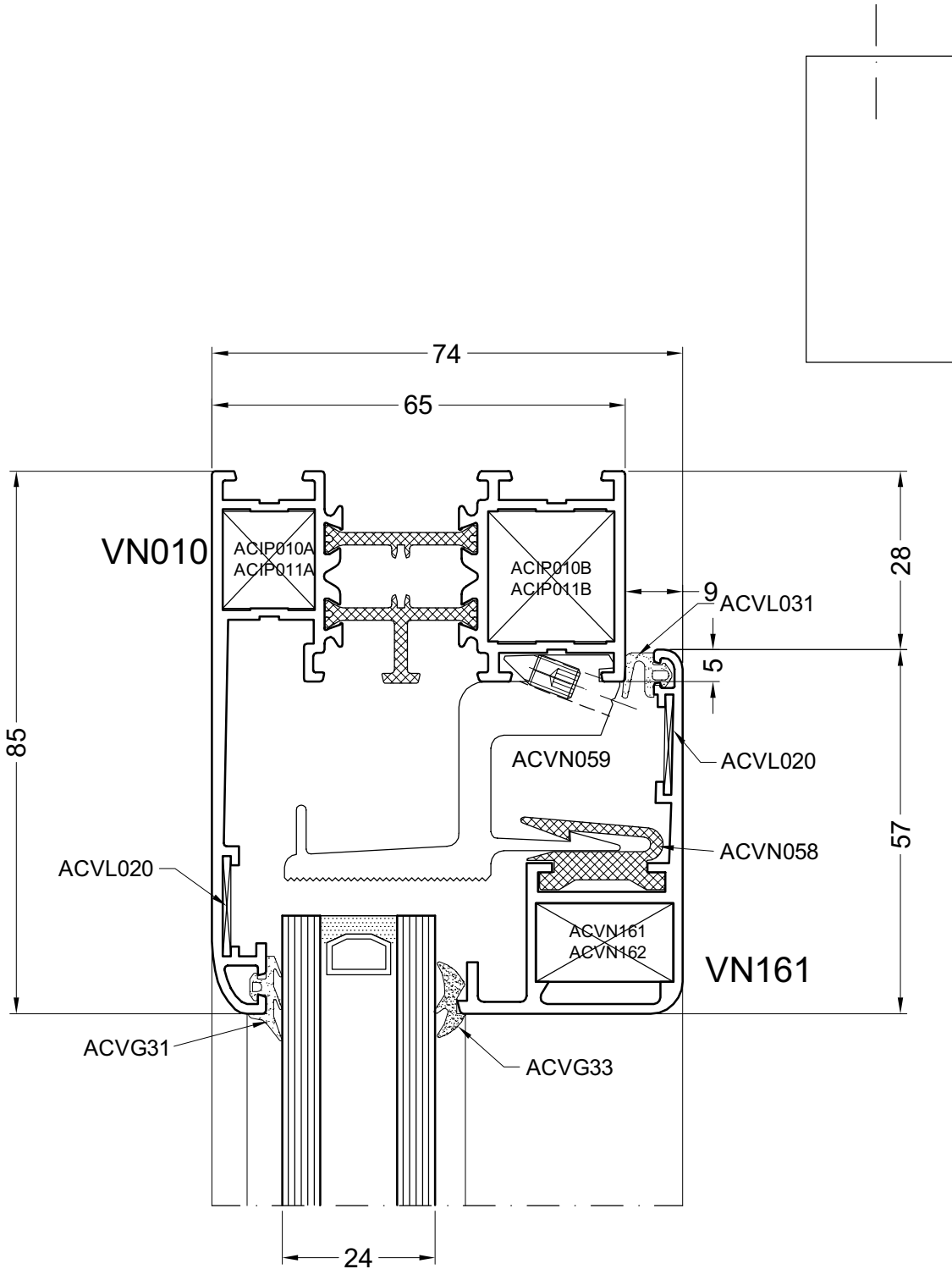

doorvn8a

8B

DOORSNEDE - COUPE - SCHNITT - SECTION

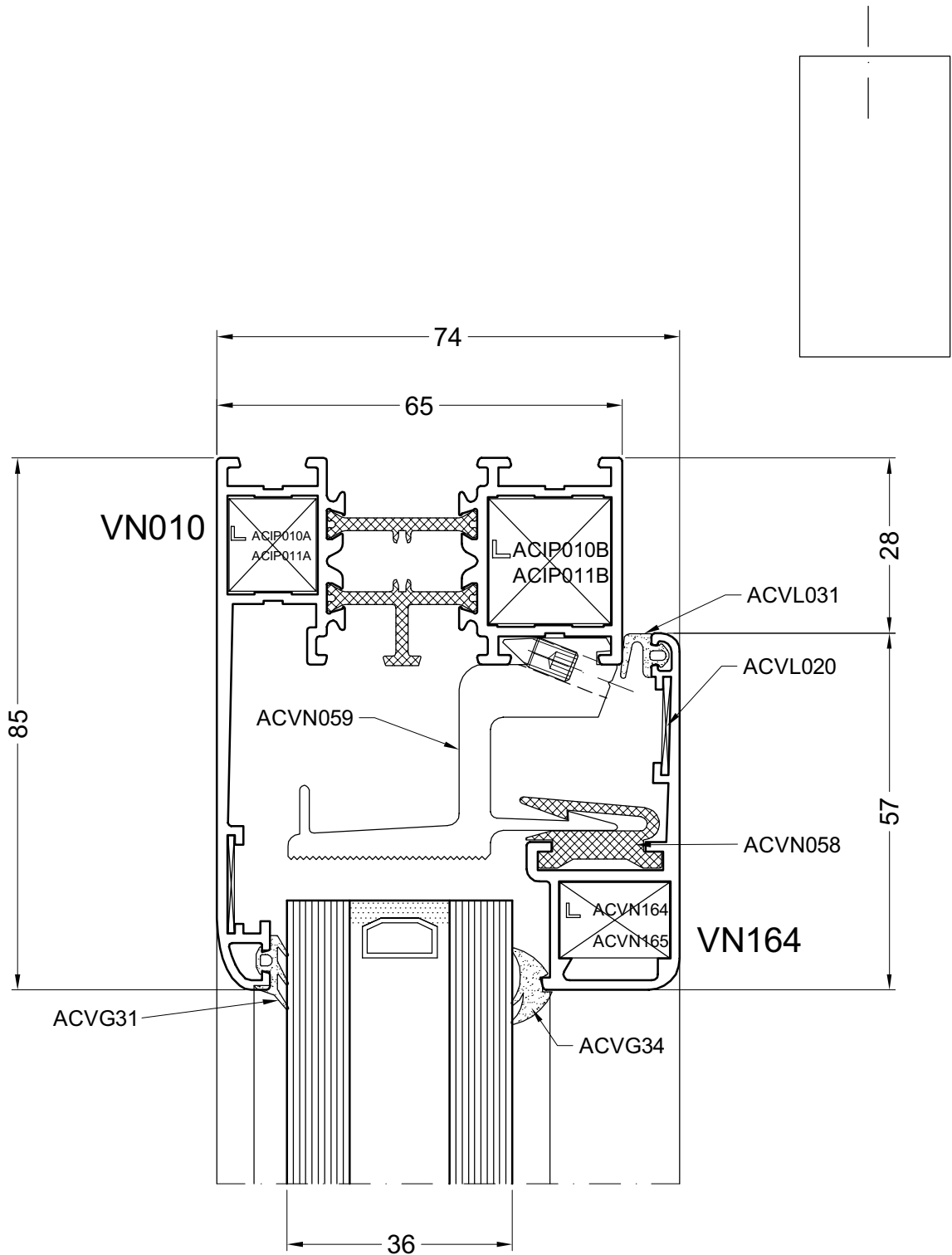

doorvn8b

9A

DOORSNEDE - COUPE - SCHNITT - SECTION

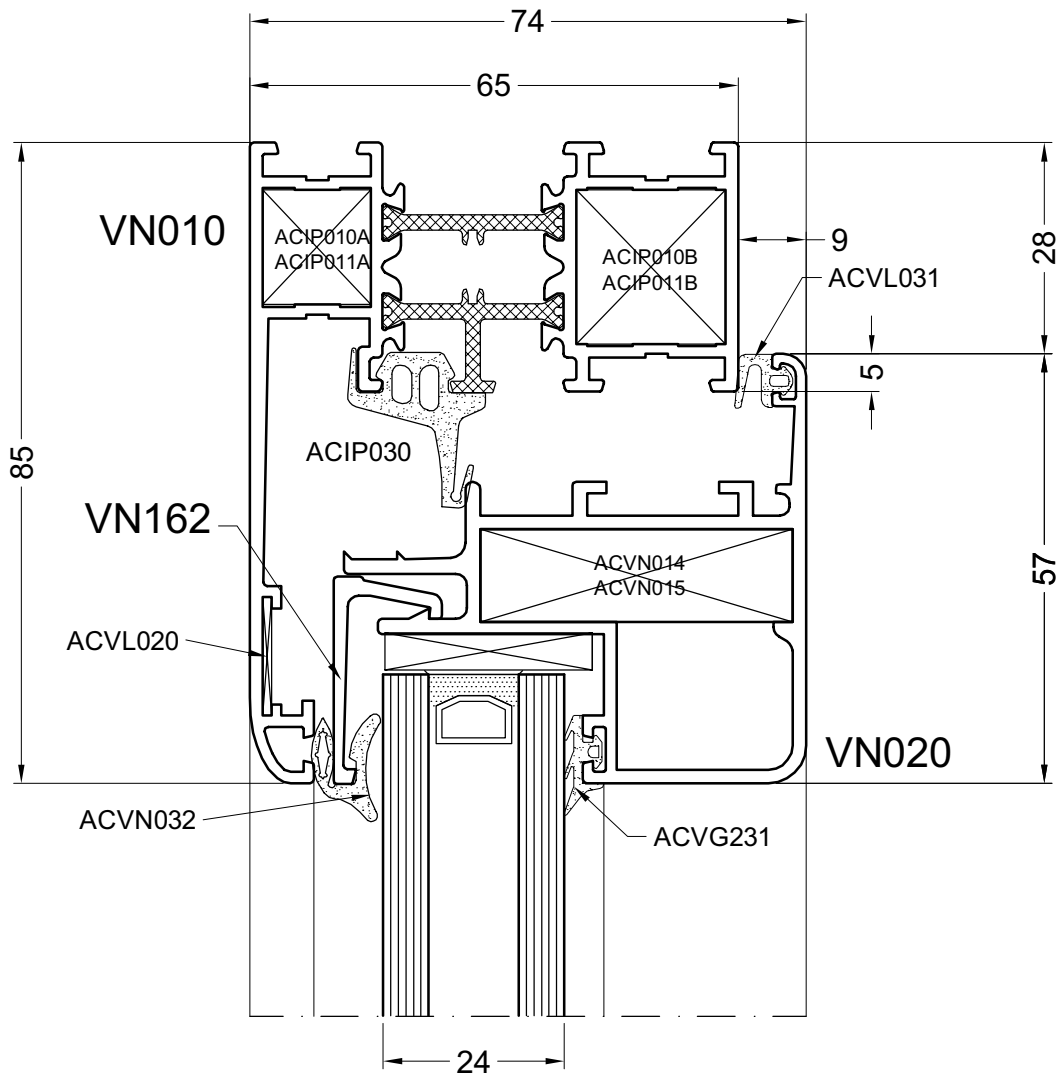
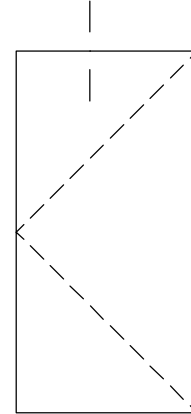

doorvn9a

9B

DOORSNEDE - COUPE - SCHNITT - SECTION

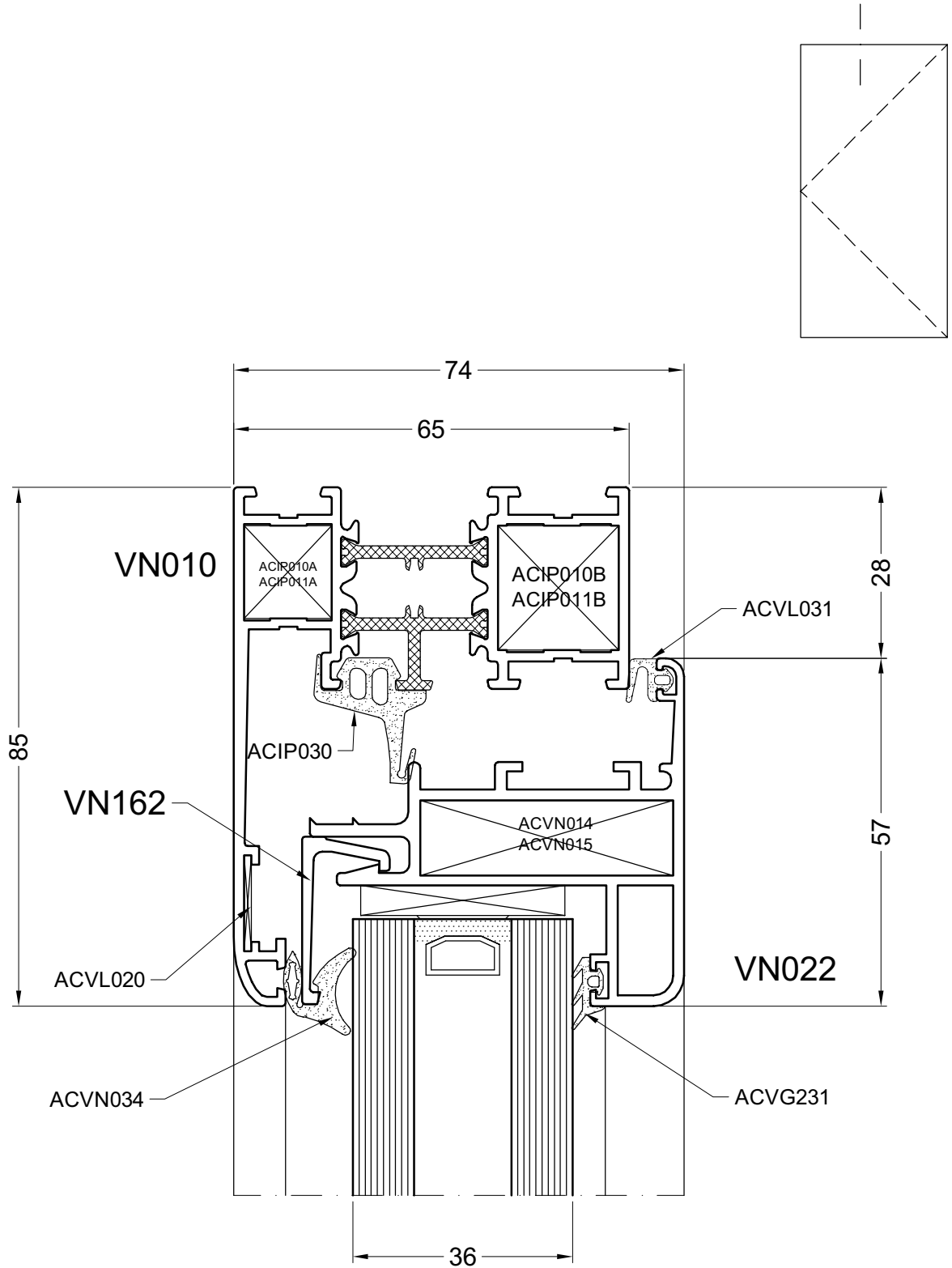

doorvn9c

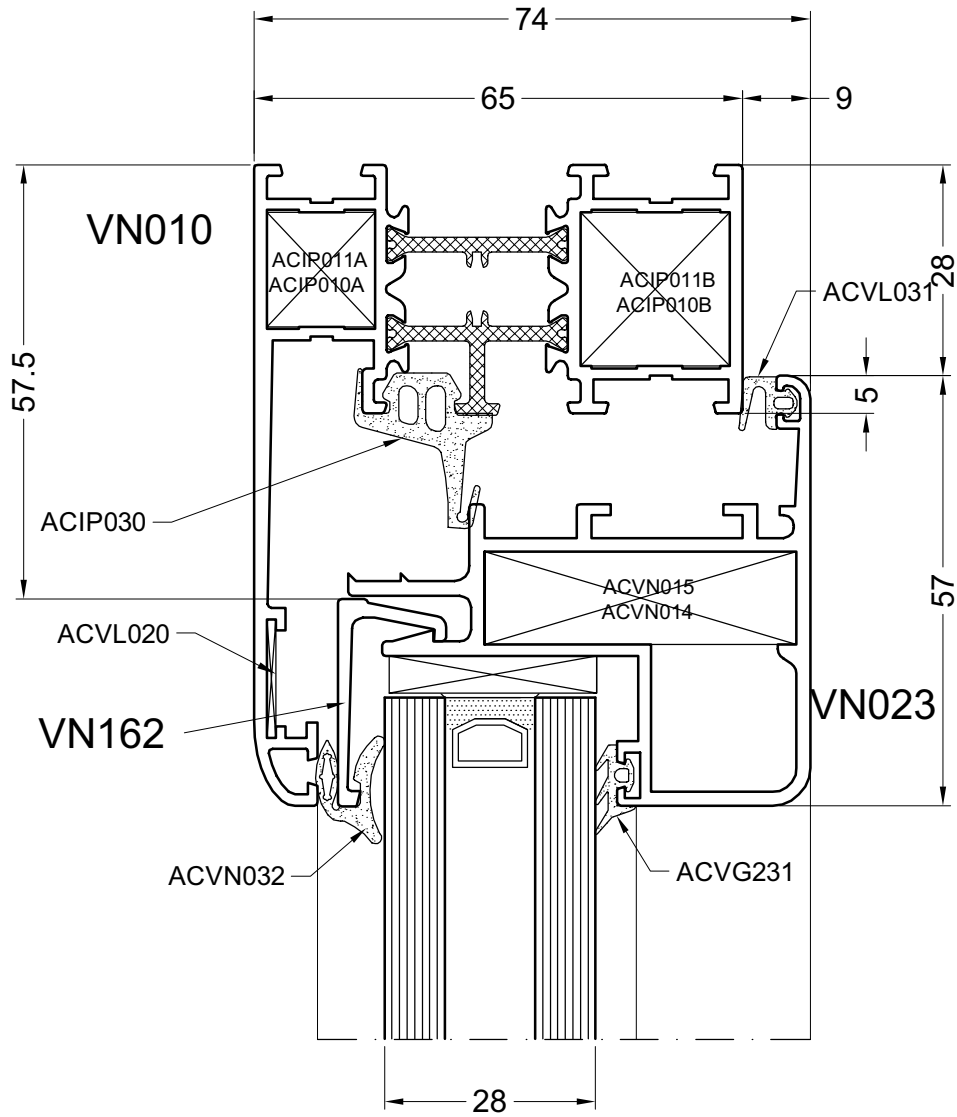
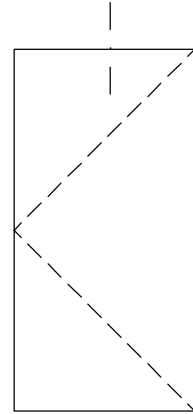

doorvn9d

9D

DOORSNEDE - COUPE - SCHNITT - SECTION

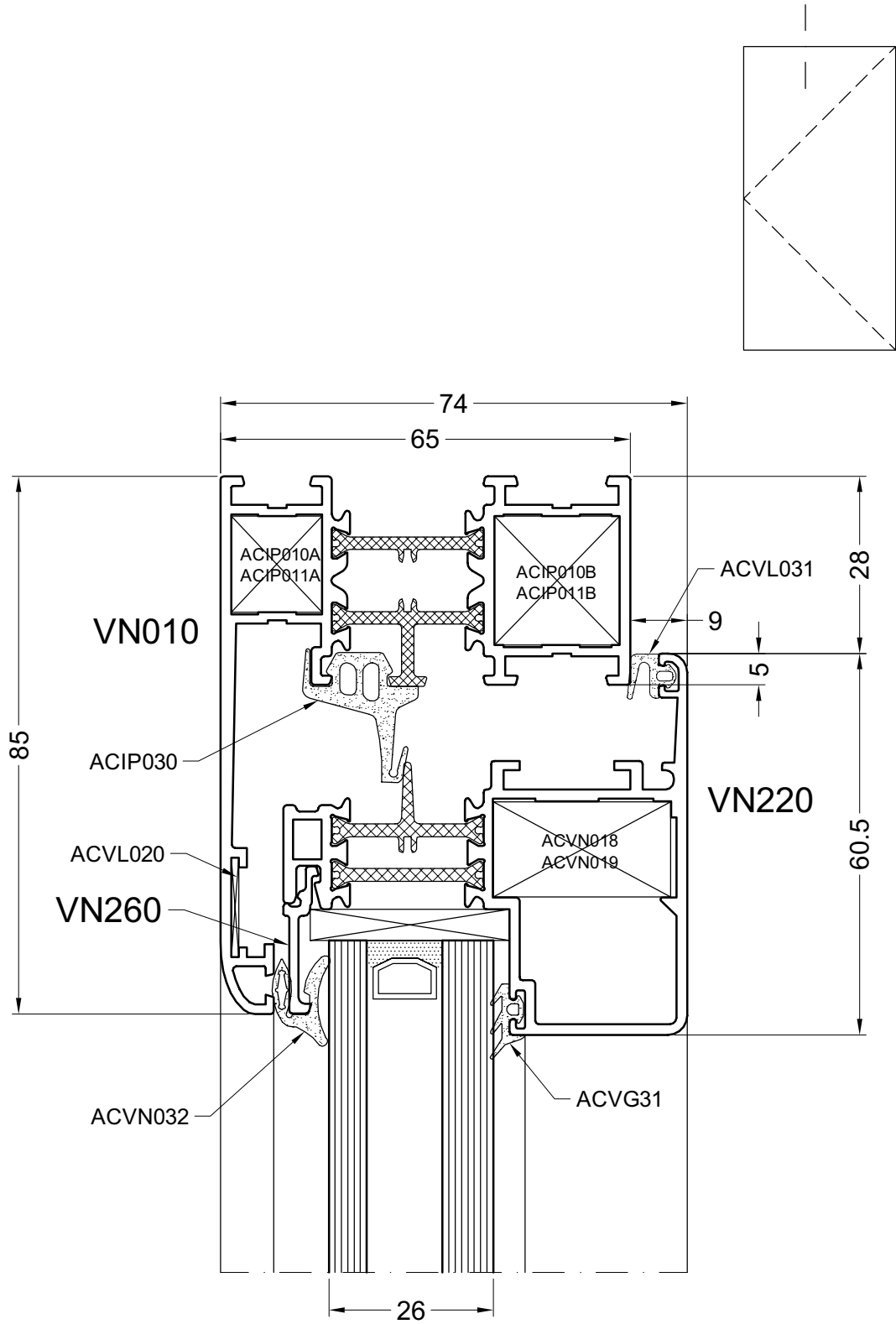

doorvn9e

10A

DOORSNEDE - COUPE - SCHNITT - SECTION

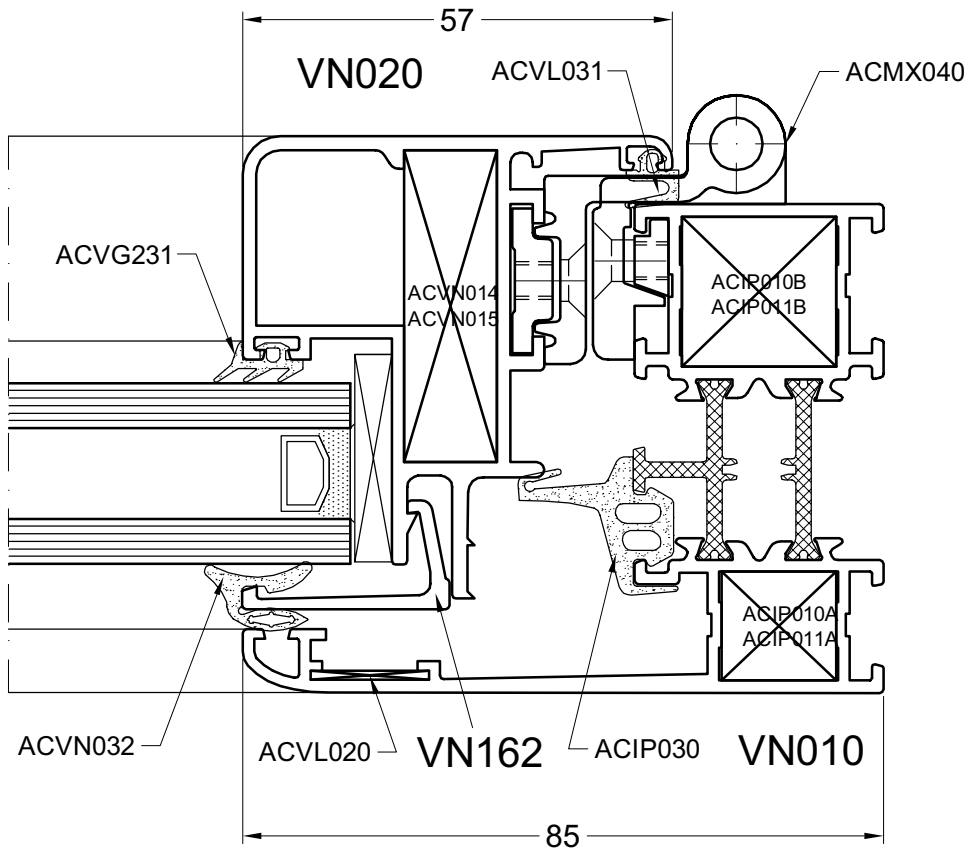
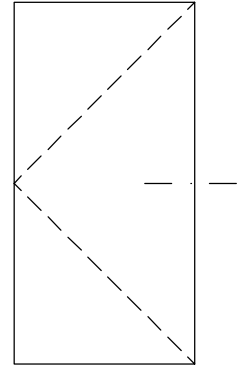

door10a

10B

DOORSNEDE - COUPE - SCHNITT - SECTION

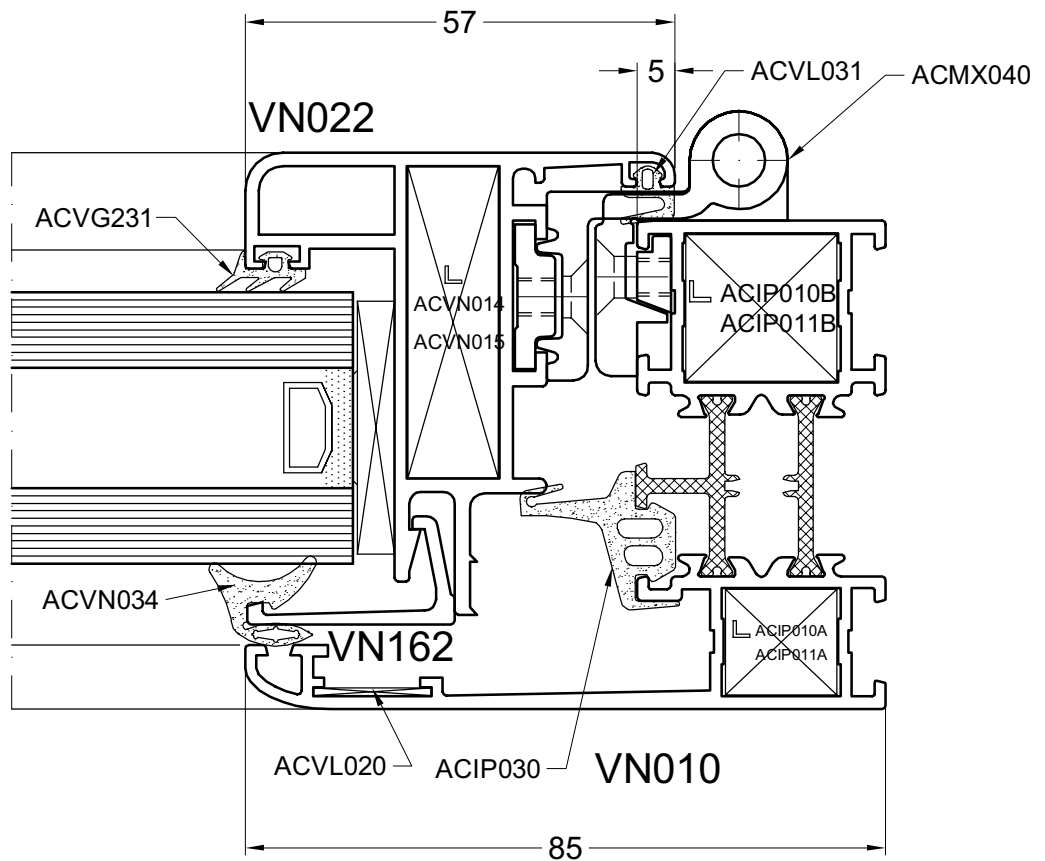
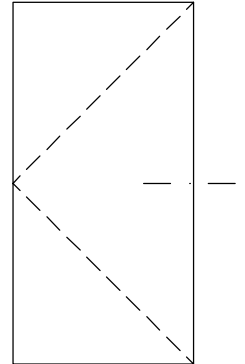

door10c

10C

DOORSNEDE - COUPE - SCHNITT - SECTION

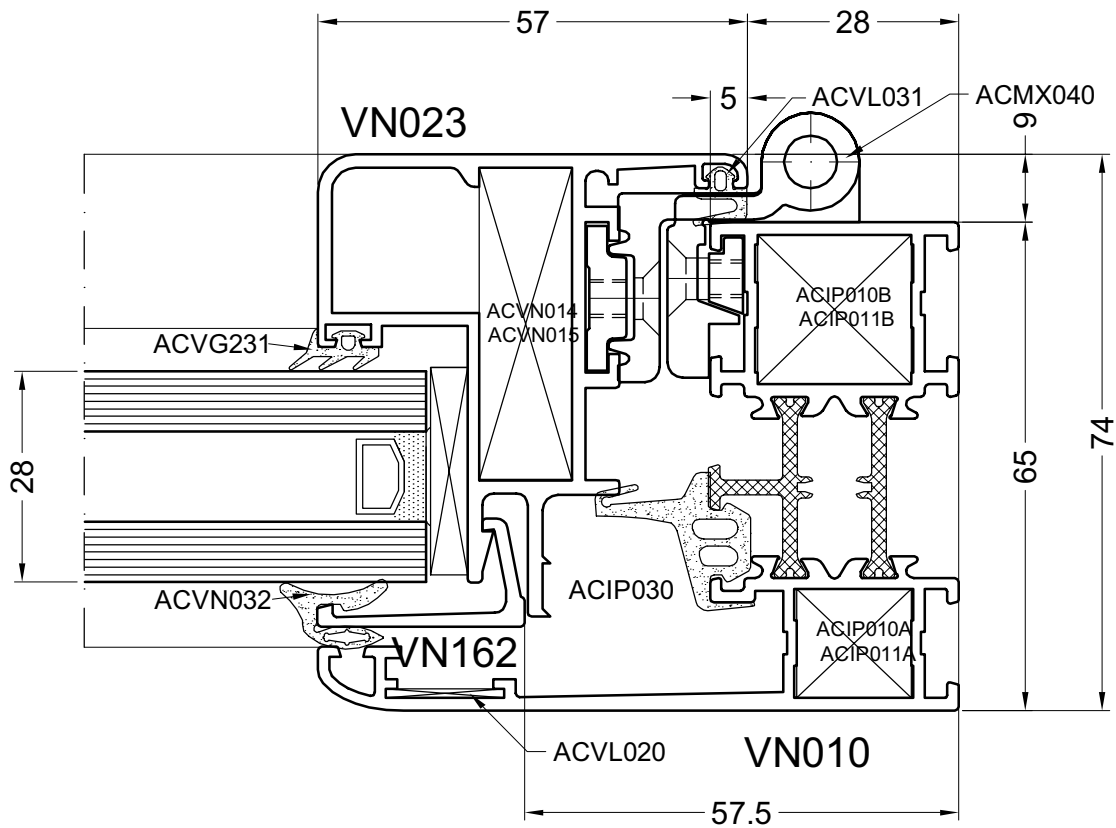
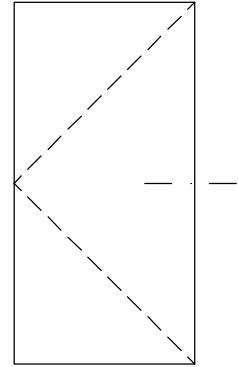

door10d

10D

DOORSNEDE - COUPE - SCHNITT - SECTION

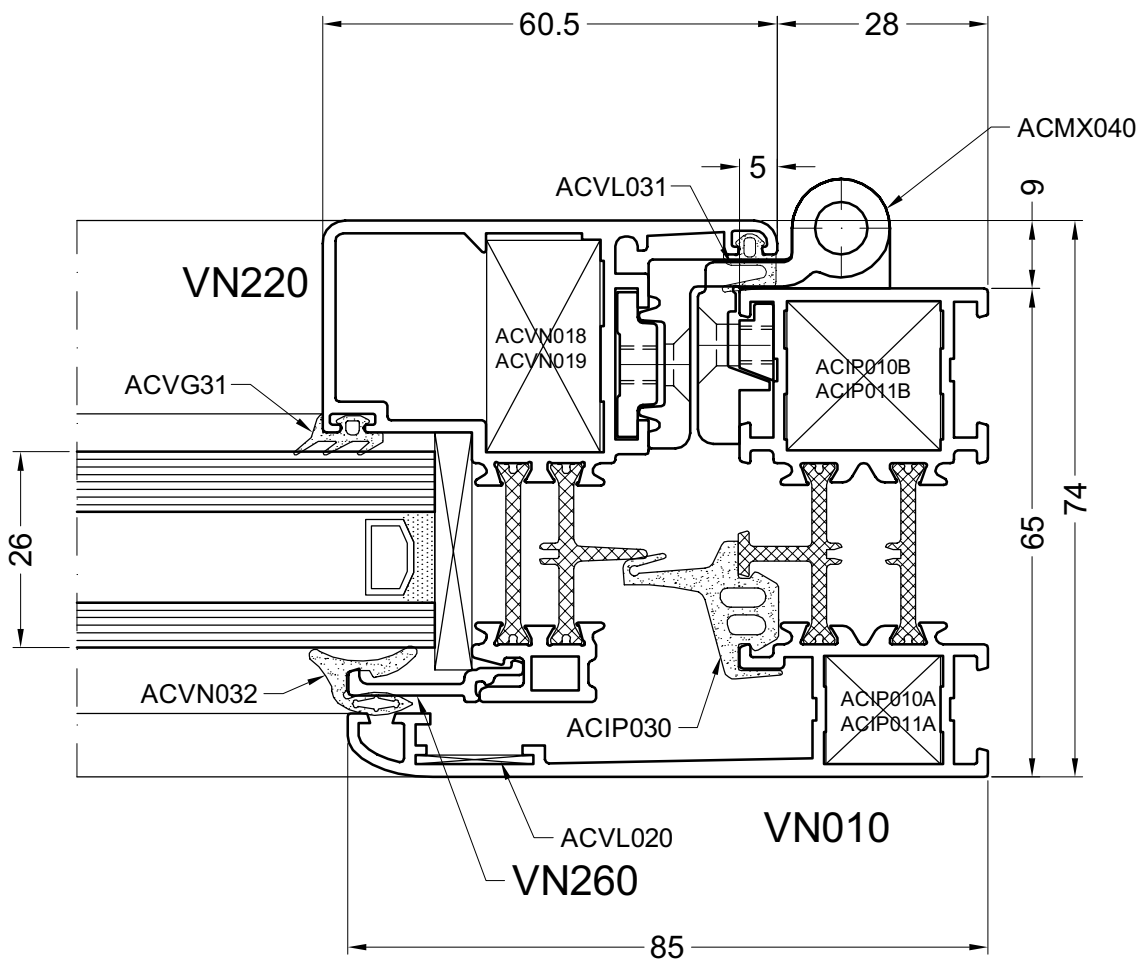
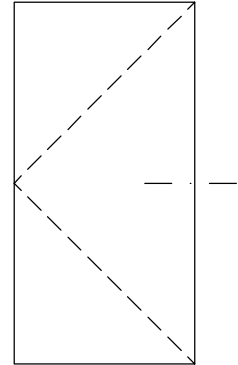

door10e

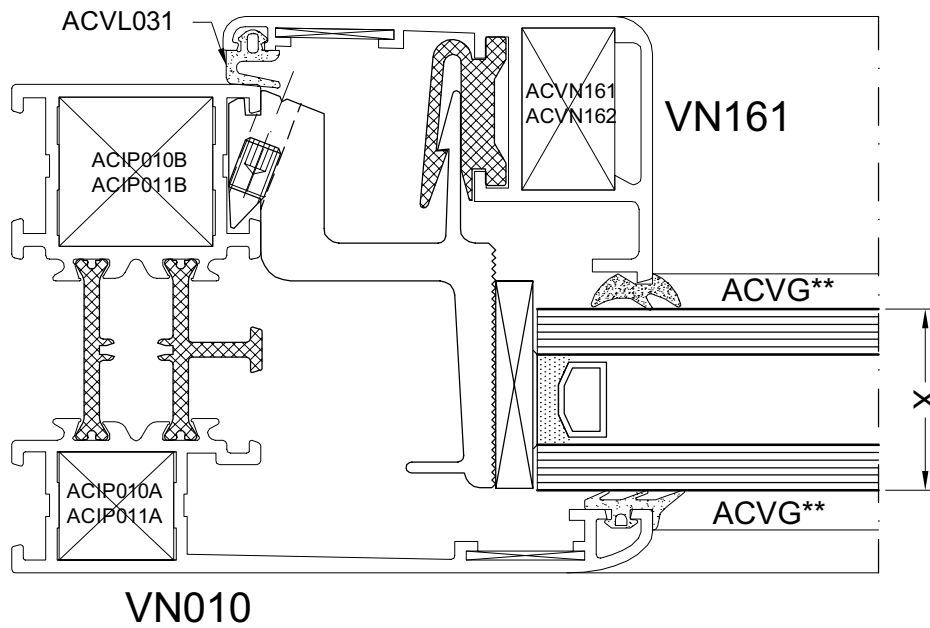

Glasdikte (X) Epaisseur de vitrage Glas dicke Glazing thickness	Rubber Buiten Joint de vitrage exterieur glasanlage dichtung glazing gasket outside	Rubber Binnen joint de vitrage glas dichtung glazing gasket	Glaslat latte a vitrage glasleitte glazing bead
20 mm	ACVG131	ACVG340	VN161
21 mm	ACVG131	ACVG34	VN161
22 mm	ACVG31	ACVG340	VN161
23 mm	ACVG31	ACVG34	VN161
24 mm	ACVG31	ACVG33	VN161
25 mm	ACVG31	ACVG32	VN161
26 mm	ACVG231	ACVG32	VN161

glast1a

GLASTABELLEN
TABLES DE VITRAGE
BEGLAZUNG TABELLEN
GLAZING TABLES

DOORSNEDE - COUPE - SCHNITT - SECTION

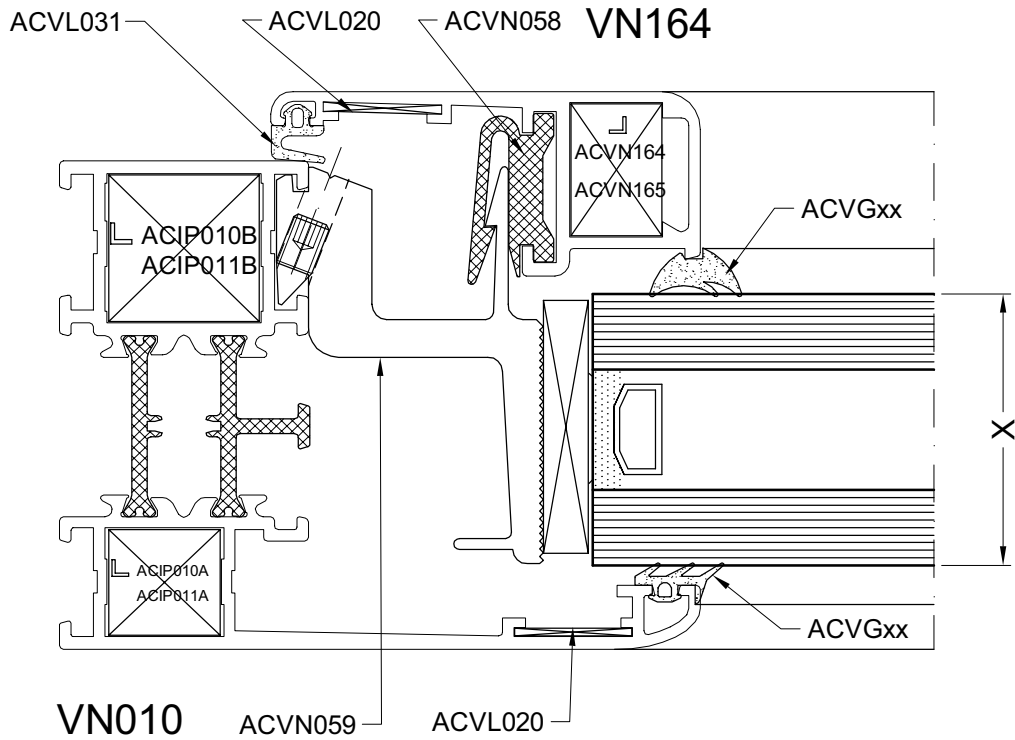

Glasdikte (X) Epaisseur de vitrage Glas dicke Glazing thickness	Rubber Buiten Joint de vitrage exterieur glasanlage dichtung glazing gasket outside	Rubber Binnen joint de vitrage glas dichtung glazing gasket	Glaslat latte a vitrage glasleitte glazing bead
33 mm	ACVG131	ACVG340	VN164
34 mm	ACVG131	ACVG34	VN164
35 mm	ACVG31	ACVG340	VN164
36 mm	ACVG31	ACVG34	VN164
37 mm	ACVG31	ACVG33	VN164
38 mm	ACVG31	ACVG32	VN164
39 mm	ACVG231	ACVG32	VN164

glast1b

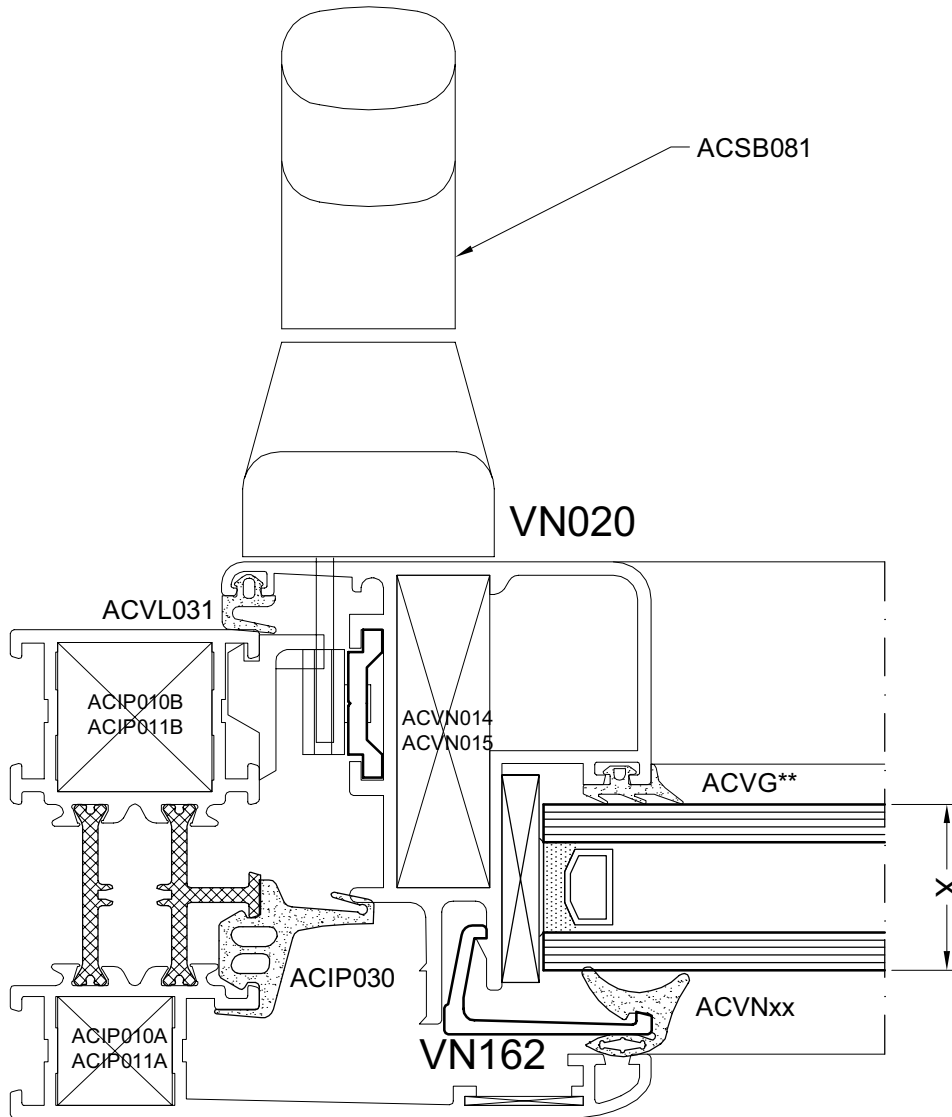

VN010

Glasdikte (X) Epaisseur de vitrage Glas dicke Glazing thickness	Rubber Buiten Joint de vitrage exterieur glasanlage dichtung glazing gasket outside	Rubber Binnen joint de vitrage glas dichtung glazing gasket	Glaslat latte a vitrage glasleitte glazing bead
19 mm	ACVN034	ACVG131	VN162
20 mm	ACVN034	ACVG131	VN162
21 mm	ACVN034	ACVG31	VN162
22 mm	ACVN034	ACVG231	VN162
23 mm	ACVN032	ACVG31	VN162
24 mm	ACVN032	ACVG231	VN162
25 mm	ACVN032	ACVG231	VN162

glast2a

GLASTABELLEN
TABLES DE VITRAGE
BEGLAZUNG TABELLEN
GLAZING TABLES

DOORSNEDE - COUPE - SCHNITT - SECTION

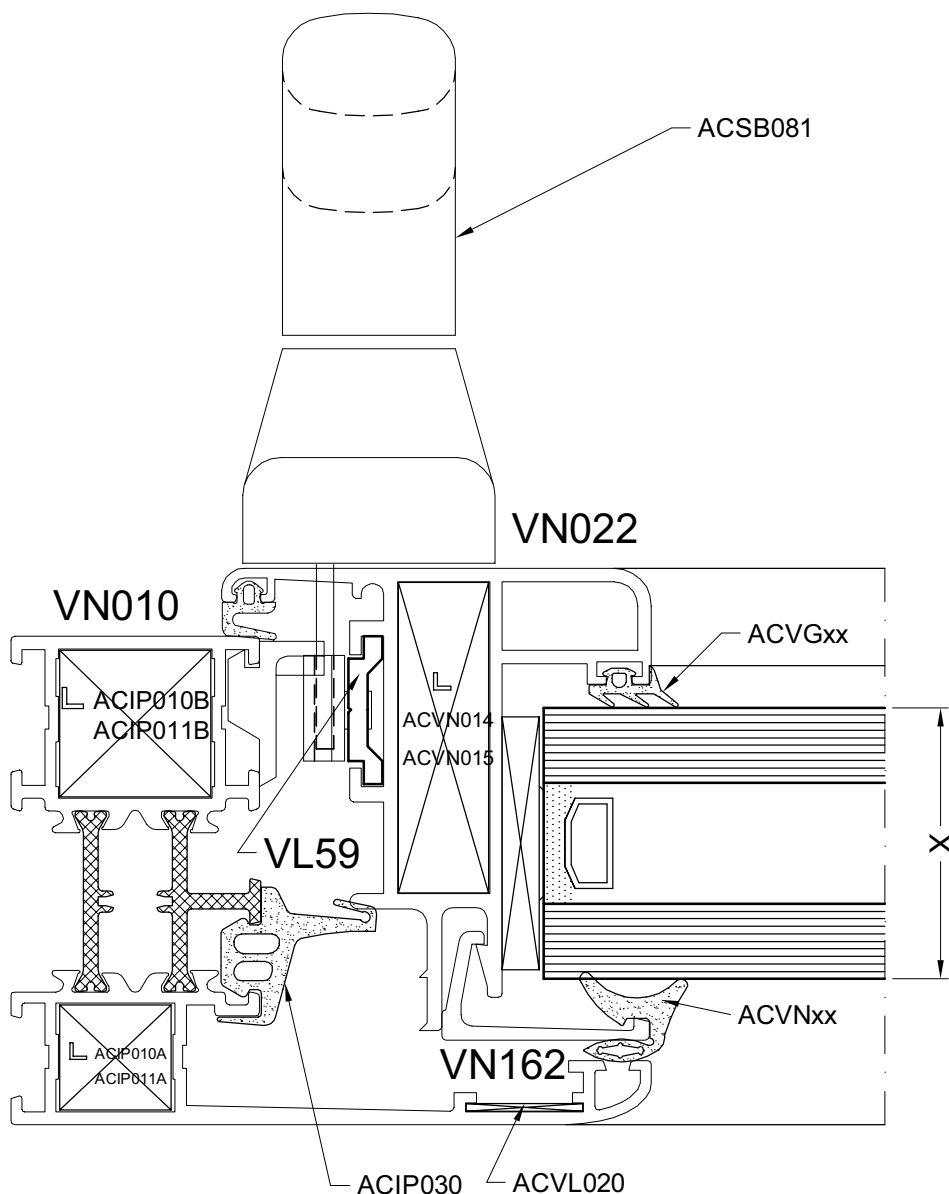

Glasdikte (X) Epaisseur de vitrage Glas dicke Glazing thickness	Rubber Buiten Joint de vitrage exterieur glasanlage dichtung glazing gasket outside	Rubber Binnen joint de vitrage glas dichtung glazing gasket	Glaslat latte a vitrage glasleitte glazing bead
33 mm	ACVN034	ACVG131	VN162
34 mm	ACVN034	ACVG131	VN162
35 mm	ACVN034	ACVG31	VN162
36 mm	ACVN034	ACVG231	VN162
37 mm	ACVN032	ACVG31	VN162
38 mm	ACVN032	ACVG231	VN162
39 mm	ACVN032	ACVG231	VN162

glast2b

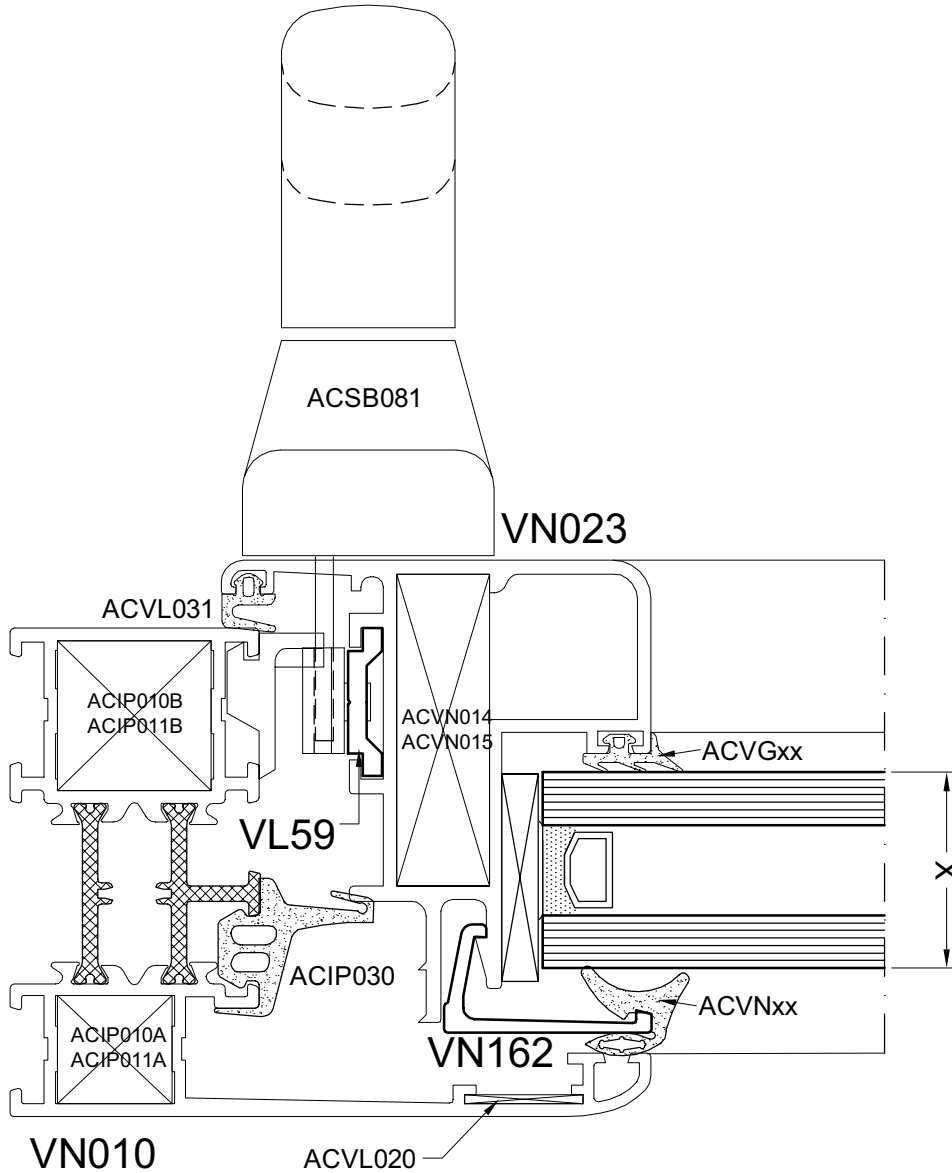

Glasdikte (X) Epaisseur de vitrage Glas dicke Glazing thickness	Rubber Buiten Joint de vitrage exterieur glasanlage dichtung glazing gasket outside	Rubber Binnen joint de vitrage glas dichtung glazing gasket	Glaslat latte a vitrage glasleite glazing bead
23 mm	ACVN034	ACVG131	VN162
24 mm	ACVN034	ACVG131	VN162
25 mm	ACVN034	ACVG31	VN162
26 mm	ACVN034	ACVG231	VN162
27 mm	ACVN032	ACVG31	VN162
28 mm	ACVN032	ACVG231	VN162
29 mm	ACVN032	ACVG231	VN162

glast2c

GLASTABELLEN
TABLES DE VITRAGE
BEGLAZUNG TABELLEN
GLAZING TABLES

DOORSNEDE - COUPE - SCHNITT - SECTION

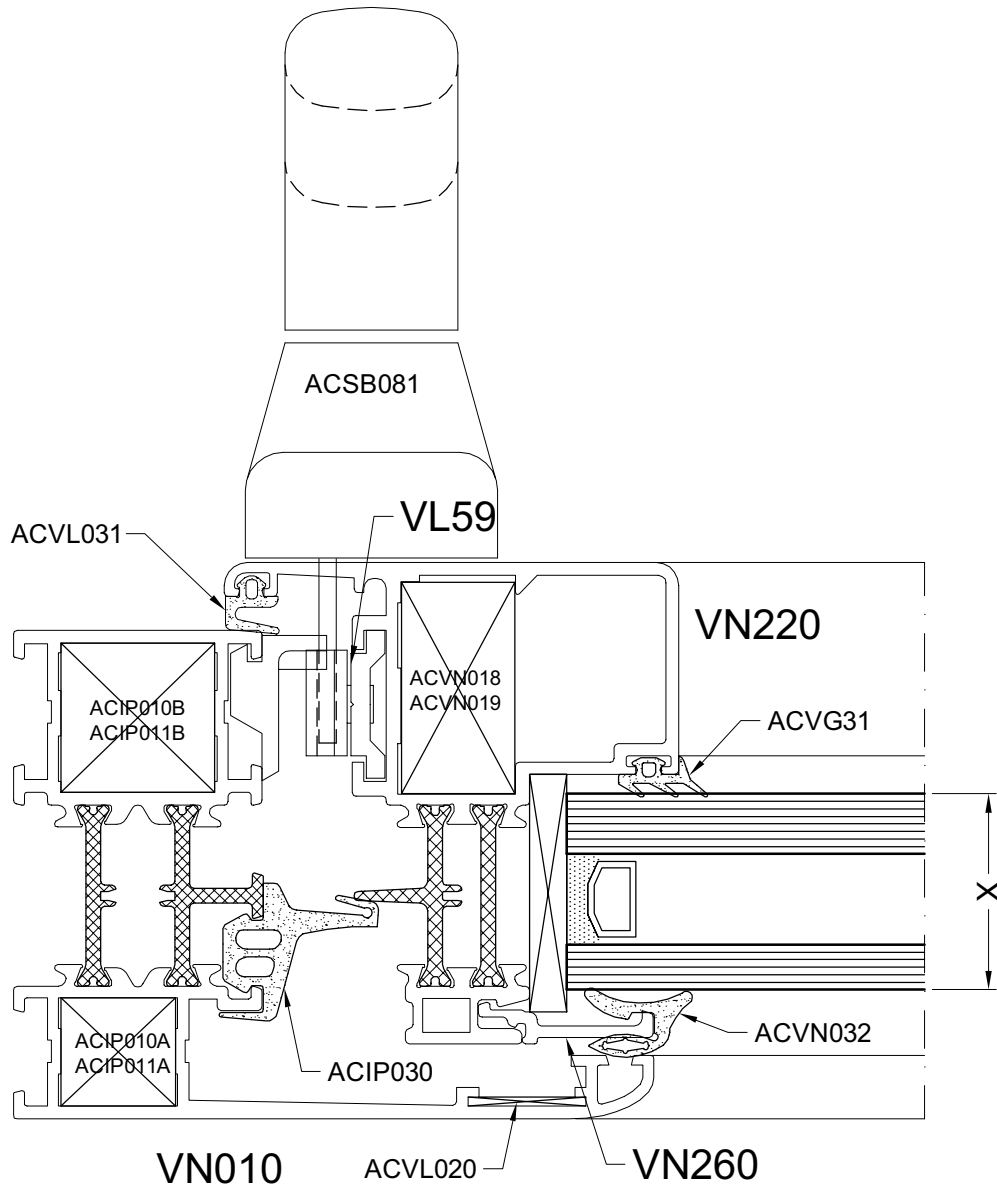

Glasdikte (X) Epaisseur de vitrage Glas dicke Glazing thickness	Rubber Buiten Joint de vitrage exterieur glasanlage dichtung glazing gasket outside	Rubber Binnen joint de vitrage glas dichtung glazing gasket	Glaslat latte a vitrage glasleitte glazing bead
20 mm	ACVN034	ACVG131	VN260
21 mm	ACVN034	ACVG131	VN260
22 mm	ACVN034	ACVG31	VN260
23 mm	ACVN034	ACVG231	VN260
24 mm	ACVN032	ACVG31	VN260
25 mm	ACVN032	ACVG231	VN260
26 mm	ACVN032	ACVG231	VN260

glast3a

VAST RAAM
CHASSIS FIXE
FEST FELD
FIXED WINDOW

ZAAGTABELLEN - TABLES DE SCIAGES - ZUSCHNITT-TABELLEN - SAWING TABLES

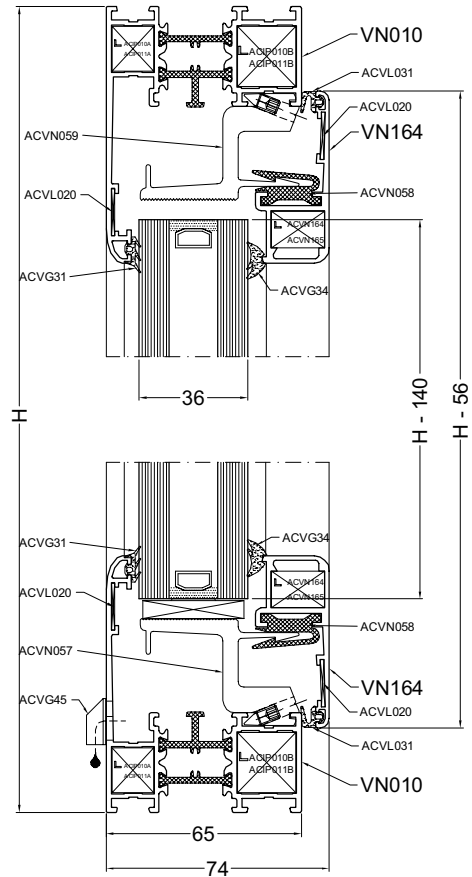
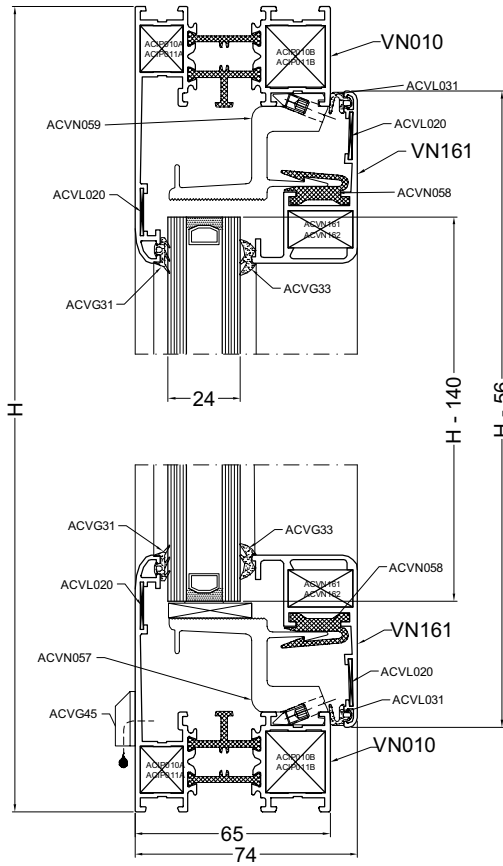

PROFIELEN PROFILES PROFILE PROFILS

VN010		2		B
VN010		2		H
VN16*		2		B - 56
VN16*		2		H - 56

TOEBEHOREN ACCESSOIRES
ZUBEHÖRTEILE ACCESSORIES

ACVL031	(B + H)x2 - 200
ACVL020	8
ACVG45	2
ACVG3x	(B + H)x2 - 550
ACVG3x	(B + H)x2 - 550
ACIP010A/11A	4
ACIP010B/11B	4
ACVN16*/16*	4
ACVN057	2
ACVN058	ACVN059 + 2

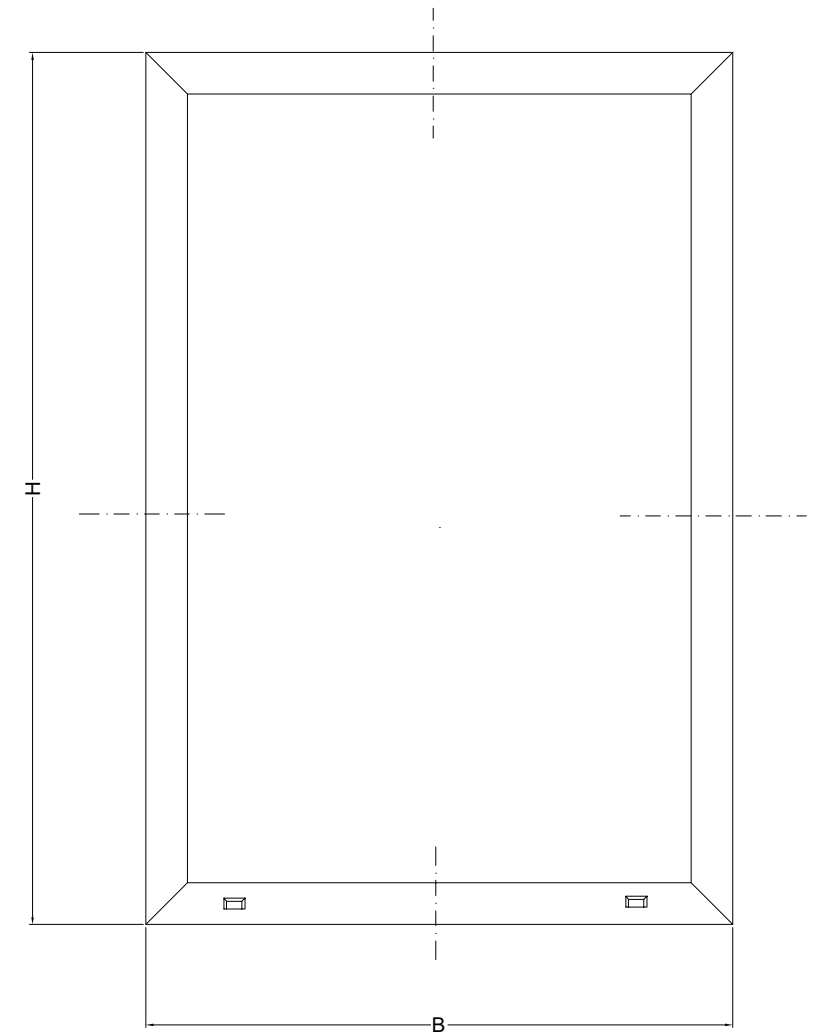
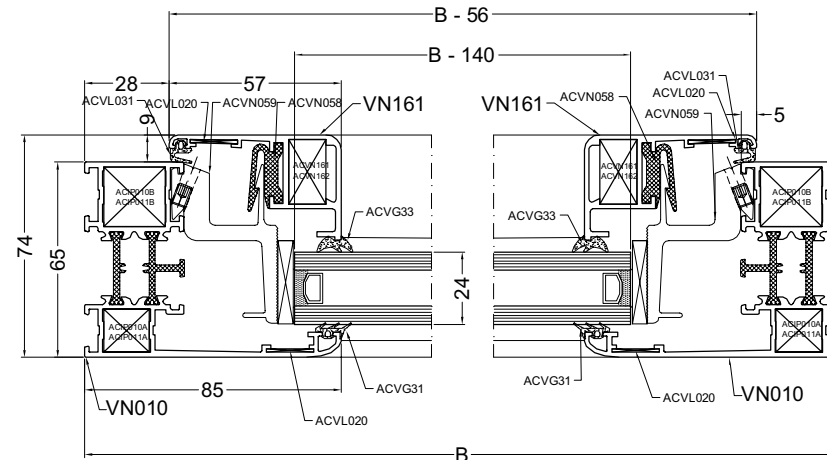

ACVN059
BEVESTIGINGSBLOKJE VOOR GLASLAT
SUPPORT POUR LATTE A VITRAGE
KLOTZ FÜR GLASLEISTE
SUPPORT FOR GLAZING BEAD

B1, H (mm)	B1 (st)	H (st)
< 800	2	4
900 - 1300	4	6
1400 - 1800	6	8
1900 - 2300	8	10
2400 - 2800	10	
2900 - 3300	12	
3400 - 3800	14	

GLASMATEN
DIMENSIONS DES VITRAGES H - 140
GLASSMASSE
GLASS SIZES B - 140

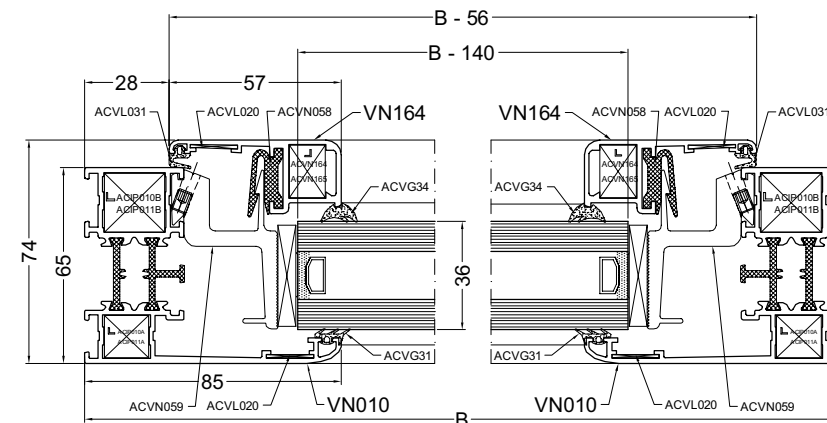

ENKEL OPENDRAAIEND RAAM
OUVRANT A LA FRANCAISE
DREHFLUGEL
CASEMENT WINDOW

ZAAGTABELLEN - TABLES DE SCIAGES - ZUSCHNITT-TABELLEN - SAWING TABLES

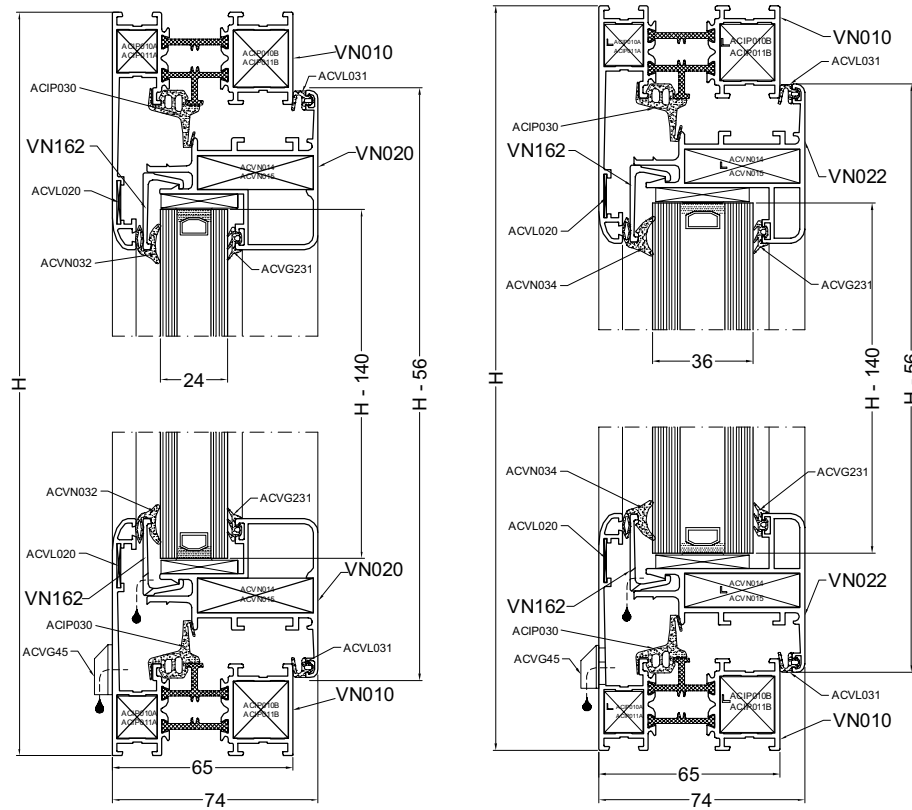

PROFIELN PROFILES PROFILE PROFILS

VN010		2		B
VN010		2		H
VN02*		2		B - 56
VN02*		2		H - 56
VN162		2		B - 115
VN162		2		H - 168
VL59		1		H1 - 135
VL59		1		H - H1 - 194

TOEBEHOREN ACCESSOIRES

ZUBEHÖRTEILE ACCESSORIES

ACVL031	(B + H)x2 - 200
ACVL020	4
ACIP030	(B + H)x2 - 200
ACVG45	2
ACVG*31	(B + H)x2 - 550
ACVN032/034	2B + 2H - 500
ACMX040	2
ACSB081	1
ACIP010A/11A	4
ACIP010B/11B	4
ACVN01*/1*	4
ACSB050	1
ACSB051	1
ACSB083	1
ACSB049	1

GLASMATEN
DIMENSIONS DES VITRAGES H - 140
GLASSMASSE
GLASS SIZES B - 140

MAX VLEUGELAFMETING B = 1200mm
MAX DIMENSIONS DU VANTAIL H = 1650mm
MAX AUSDEHNUNG DER FLÜGEL
MAX DIMENSION OF THE CASEMENT

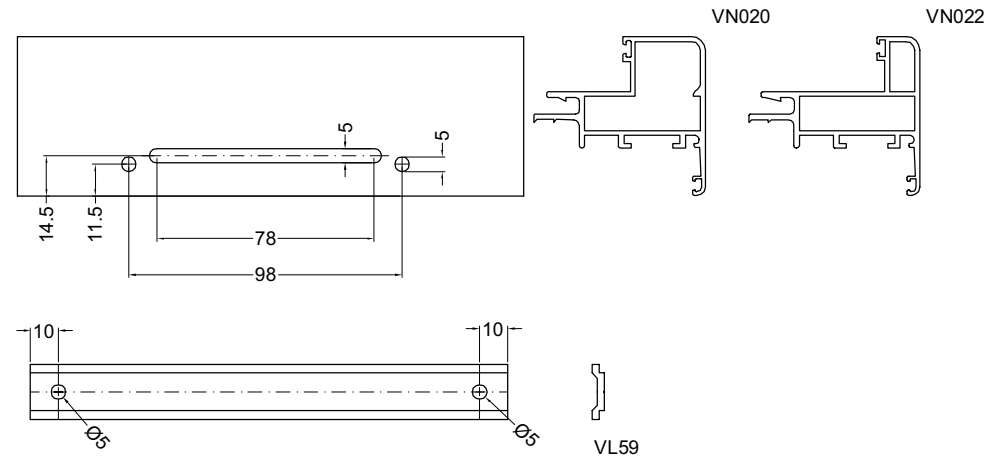
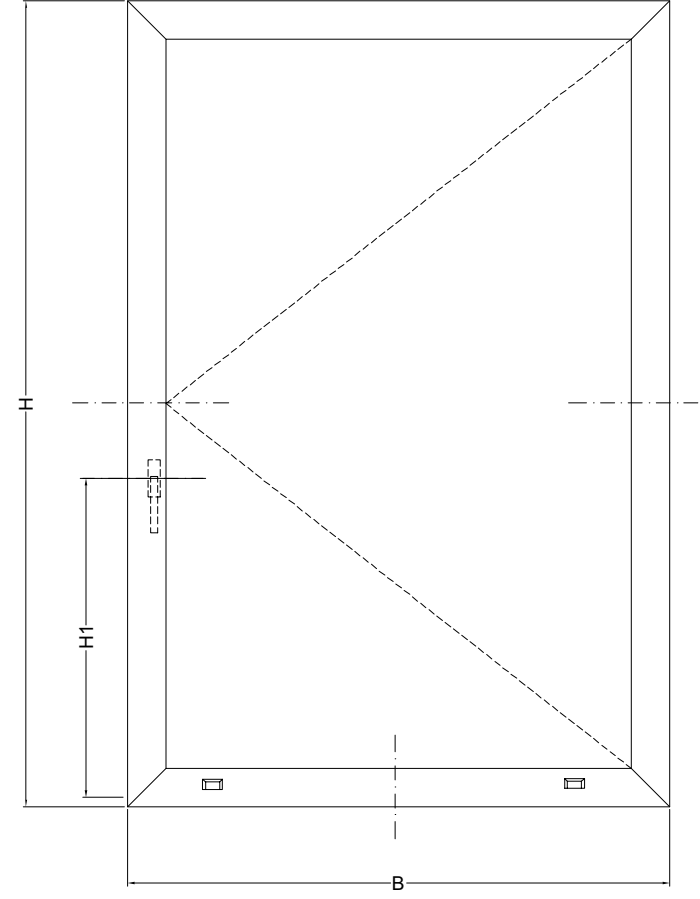
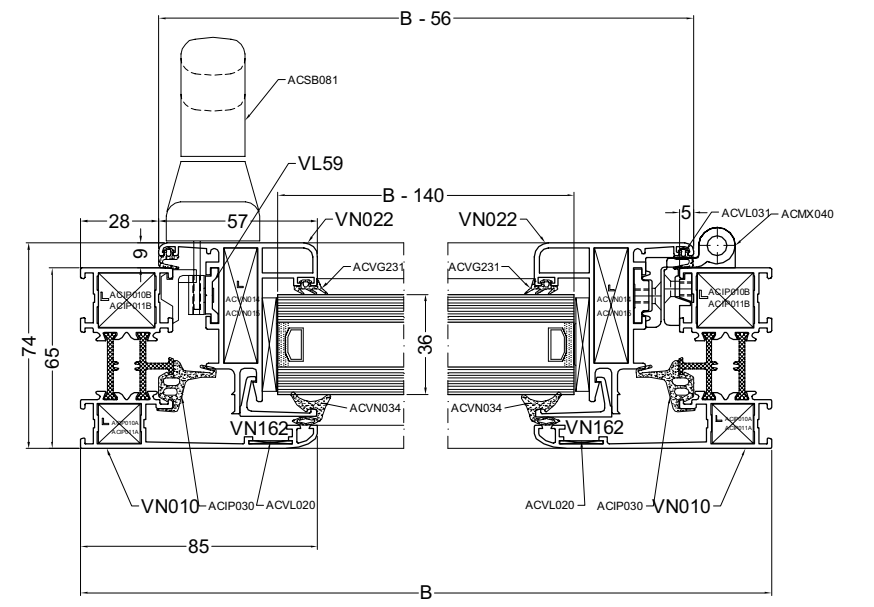
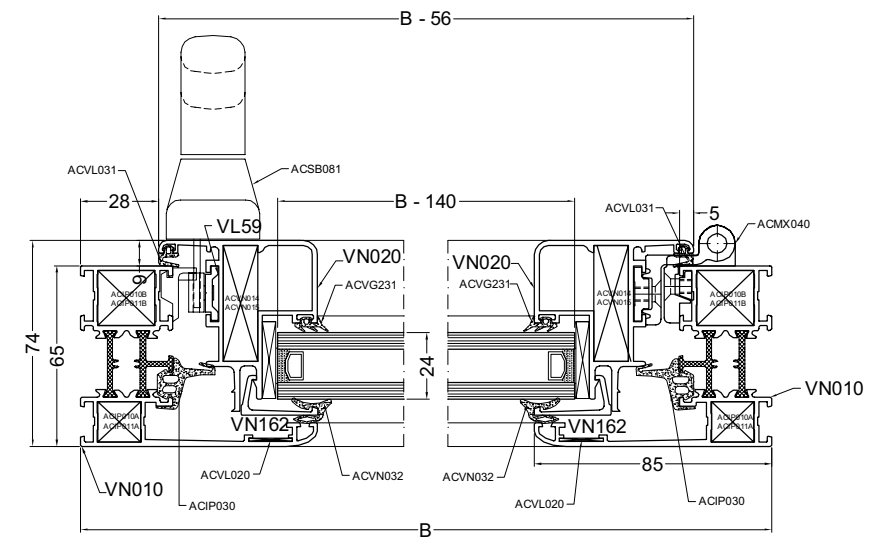

zaagb4

ENKEL OPENDRAAIEND RAAM
OUVRANT A LA FRANCAISE
DREHFLUGEL
CASEMENT WINDOW

ZAAGTABELLEN - TABLES DE SCIAGES - ZUSCHNITT-TABELLEN - SAWING TABLES

PROFIELEN PROFILES PROFILE PROFILS

VN010		2		B
VN010		2		H
VN220		2		B - 56
VN220		2		H - 56
VN260		2		B - 135
VN260		2		H - 170
VL59		1		H1 - 135
VL59		1		H - H1 - 194

TOEBEHOREN ACCESSOIRES
ZUBEHÖRTEILE ACCESSORIES

ACVL020	4
ACVL031	2x(B + H) - 200
ACIP030	2x(B + H) - 200
ACVG45	2
ACVG*31	2x(B + H) - 600
ACVN032	2x(B + H) - 500
ACMX040	3
ACSB081	1
ACIP010A/11A	4
ACIP010B/11B	4
ACVN018/19	4
ACSB050	1
ACSB051	1
ACSB083	1
ACSB049	1

MAX VLEUGELAFMETING
MAX DIMENSIONS DU VANTAIL
MAX AUSDEHNUNG DER FLÜGEL
MAX DIMENSION OF THE CASEMENT

B = 1200mm
H = 1650mm

BUITENZICHT/VUE EXTERIEUR
SICHT AUSSEN/VIEW OUTSIDE

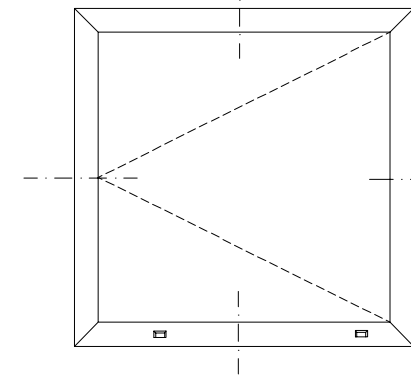

BINNENZICHT/VUE INTERIEUR
SICHT INNEN/VIEW INSIDE

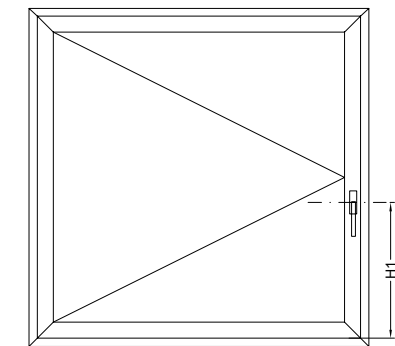

GLASMATEN
DIMENSIONS DES VITRAGES
GLASMASSE
GLASS SIZES

H - 146.5
B - 146.5

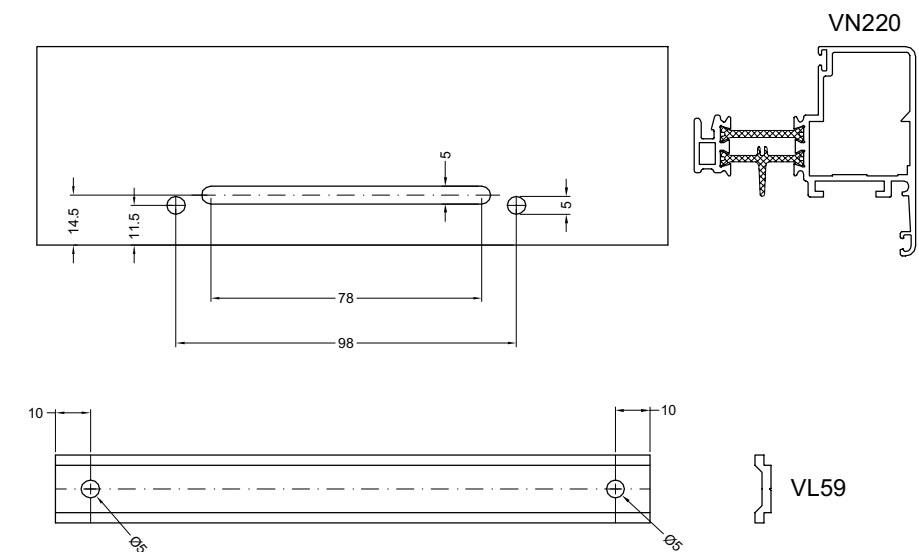
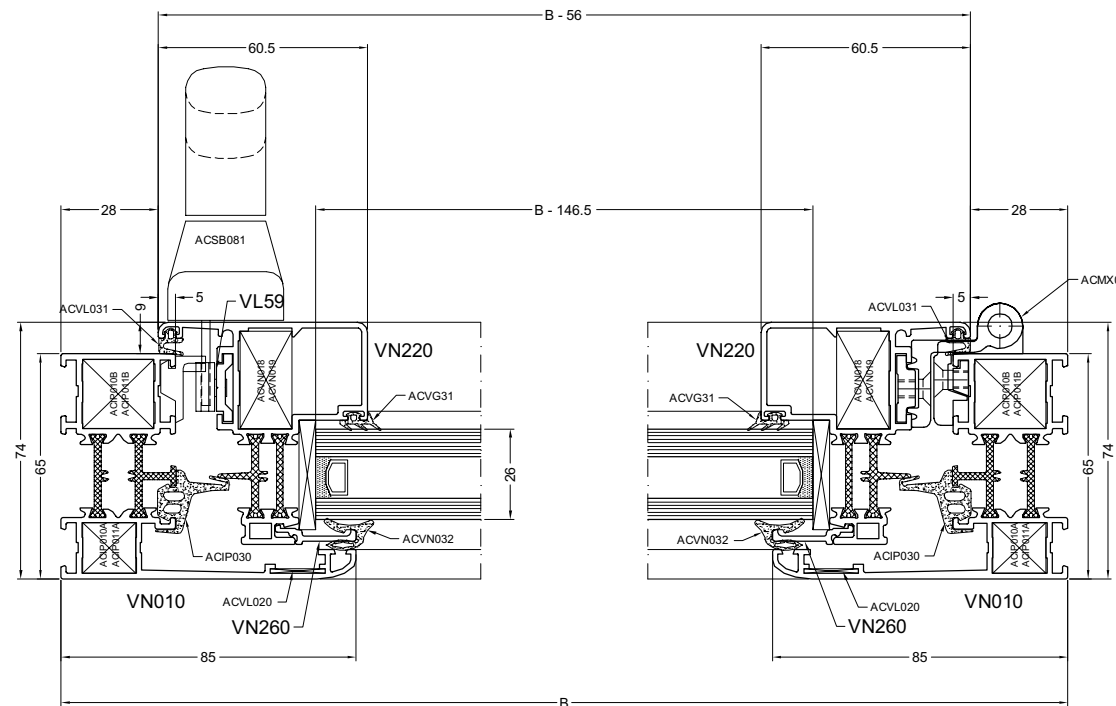
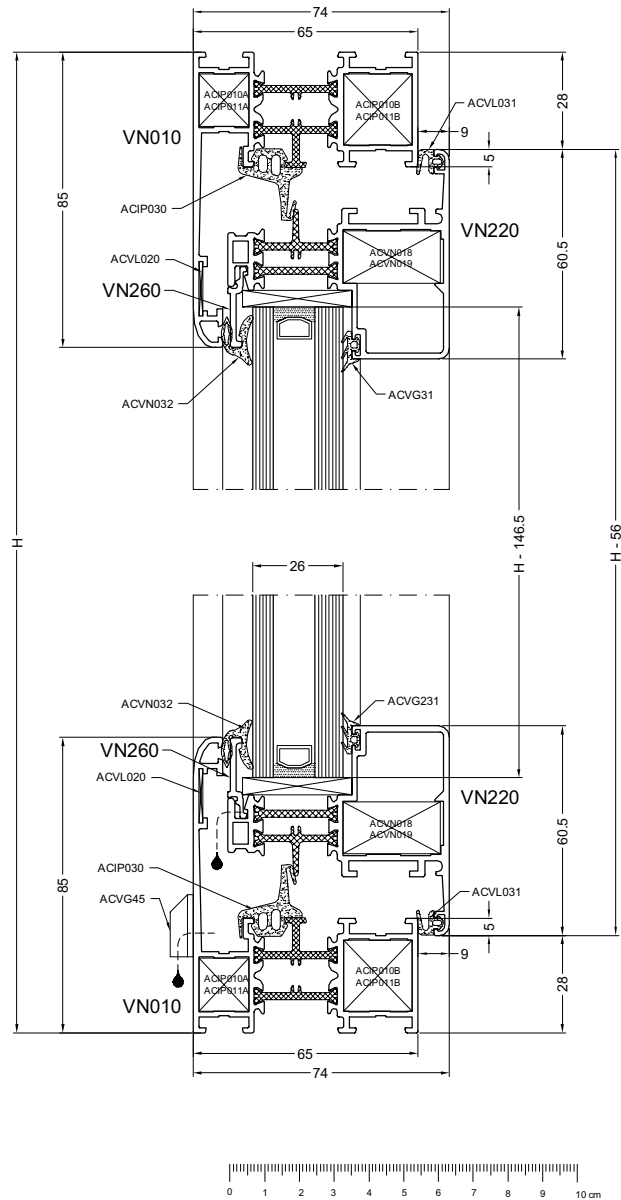

MONTAGE VN010 - VN032
MONTAGE VN010 - VN032
ZUSAMMENBAU VN010 - VN032
ASSEMBLY VN010 - VN032

ZAAGTABELLEN - TABLES DE SCIAGES - ZUSCHNITT-TABELLEN - SAWING TABLES

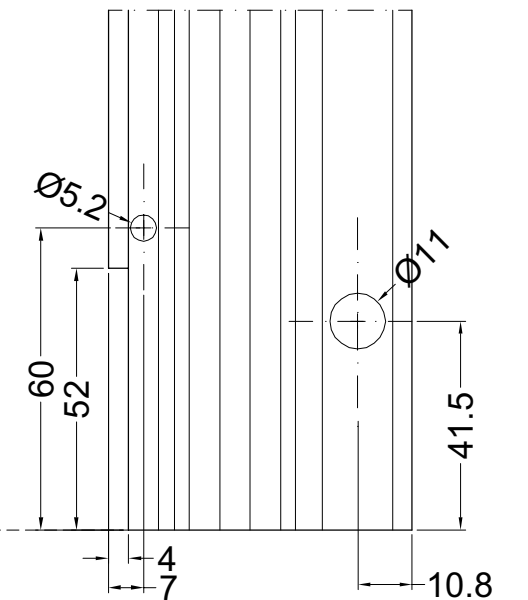
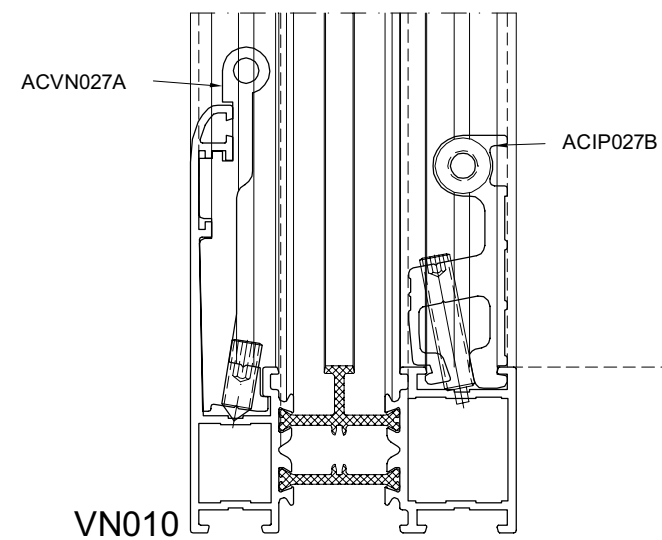
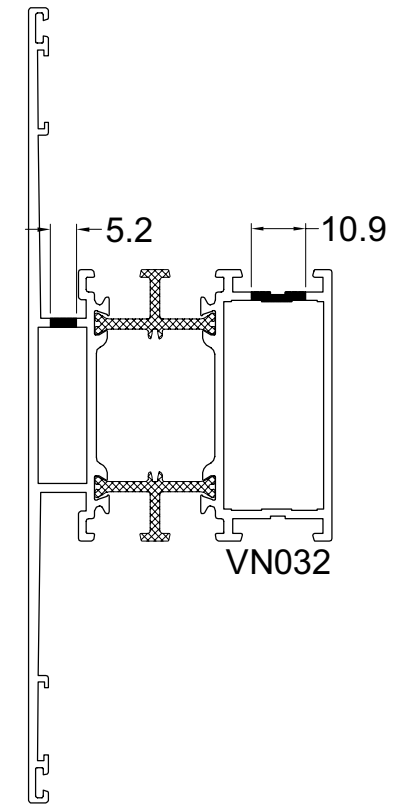
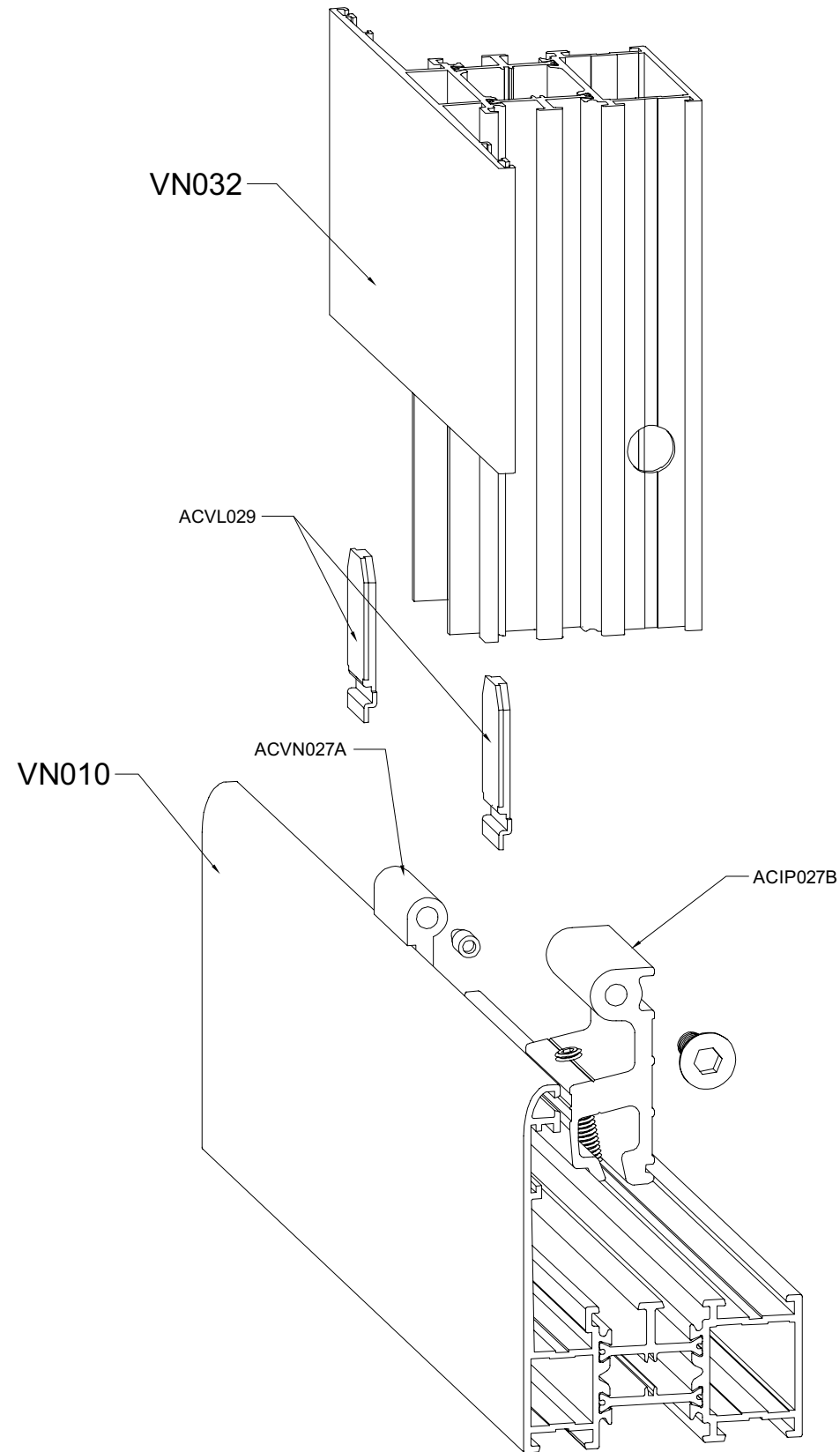

mont1

UITSPARING VN162
ENTAILLE VN162
EINBAU VN162
MACHINING VN162

ZAAGTABELLEN - TABLES DE SCIAGES - ZUSCHNITT-TABELLEN - SAWING TABLES

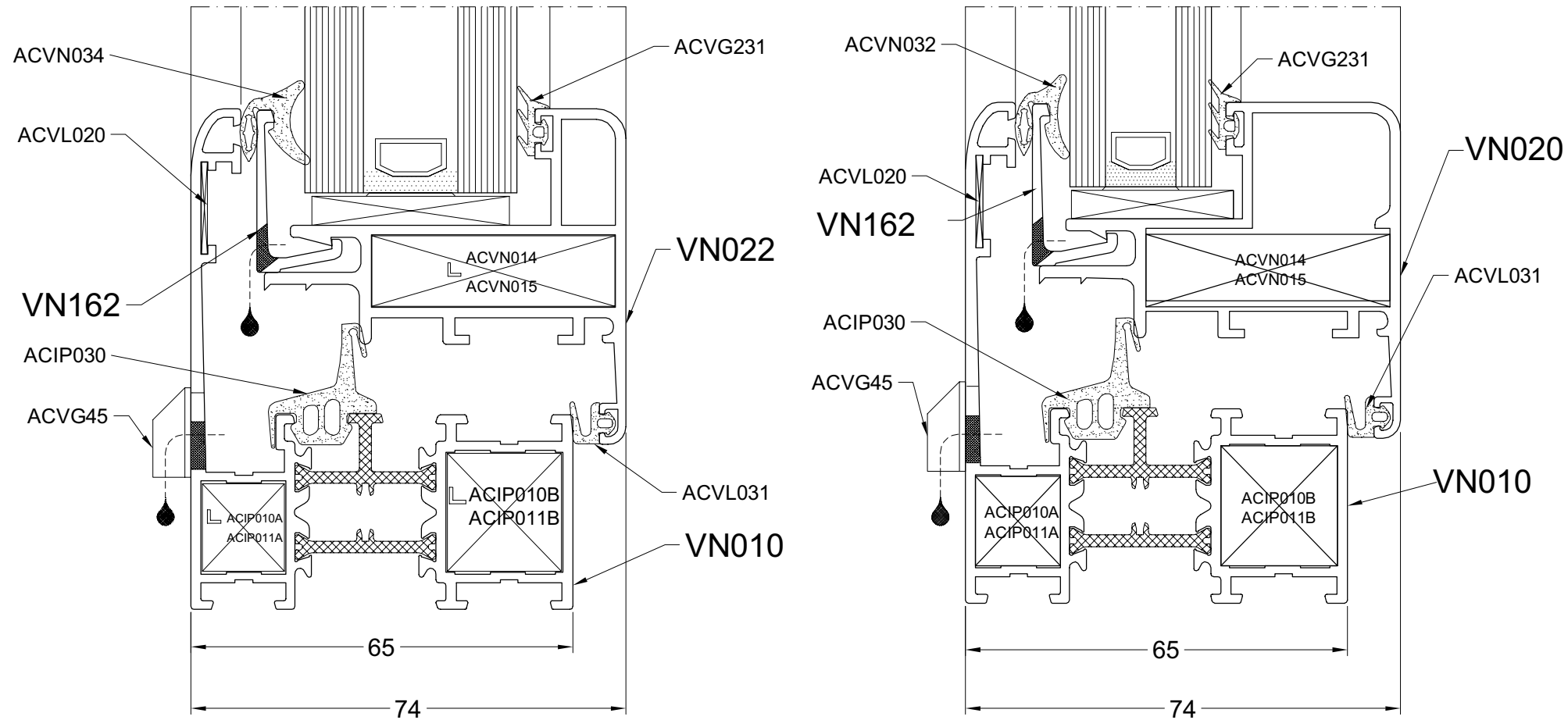

BUITENZICHT/VUE EXTERIEUR
SICHT AUSSEN/VIEW OUTSIDE

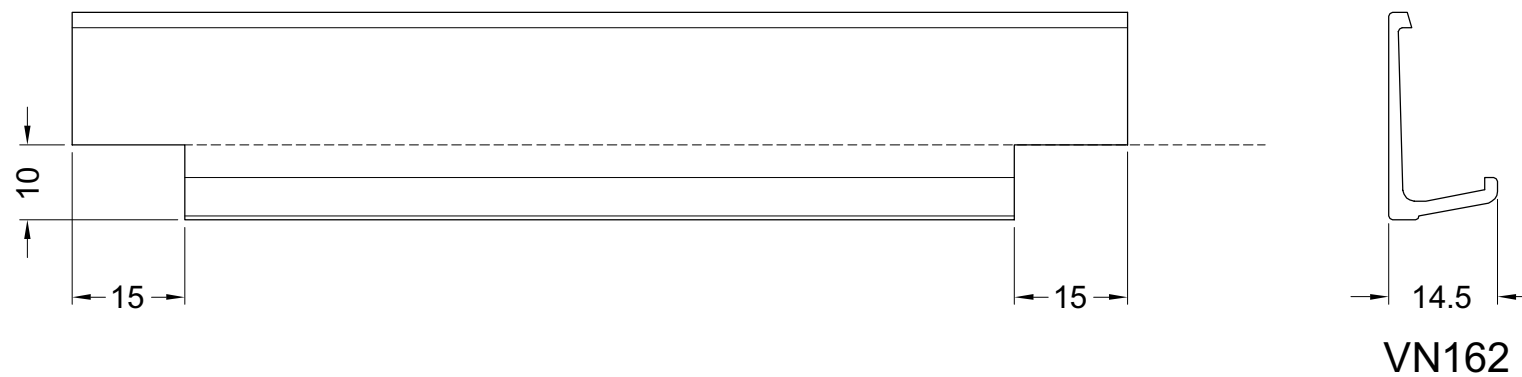
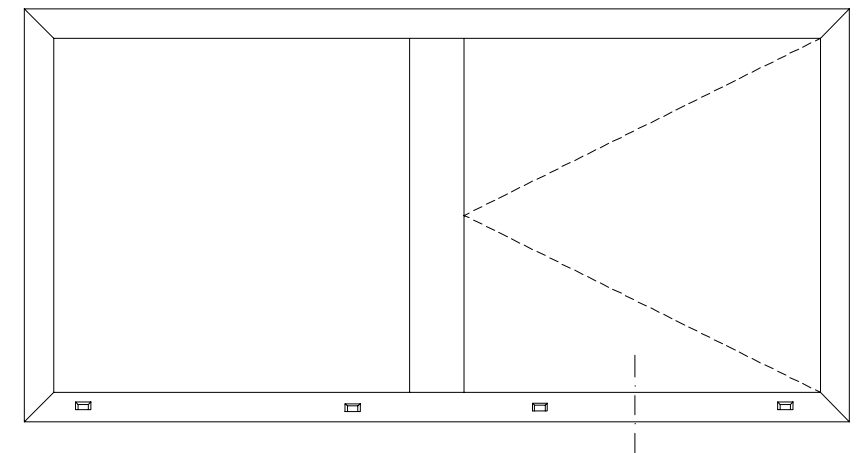

VN162