

alidoor

BINNENDEUREN
PORTES INTERIEURES
INNER TUR
INSIDE DOORS

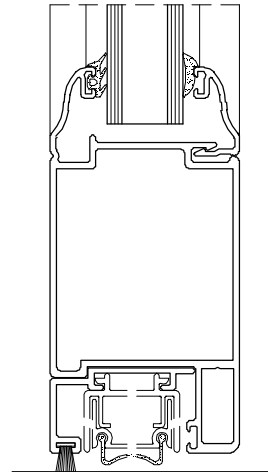

ADa

PROFIELEN _____ P. 5

PROFILS
PROFILE
PROFILES

ADb

TOEBEHOREN _____ P. 9

ACCESSOIRES
ZUBEHORTEILE
ACCESSORIES

ADc

DOORSNEDEN _____ P. 19

COUPES
SCHNITT
SECTIONS

ADd

ZAAGTABELLEN _____ P. 35

TABLES DE SCIAGES
ZUSCHNITT-TABELLEN
SAWING TABLES

ADe

WERKTEKENINGEN _____ P. 41

DESSINS DE CONSTRUCTION
KONSTRUKTIONZEICHNUNGEN
CONSTRUCTION DRAWINGS

AFKORTINGEN / ABBREVIATIONS / ABKURZUNGEN / ABBREVIATIONS

BR = BRUT - BRUT - ROH - BRUT

AN = GEANODISEERD - ANODISE - ELOXIERT - ANODISED

AN (■) = GELAKT - LAQUE - LACKIERT - LACQUERED -- RAL9006M

KL = STANDAARDKLEUREN - COULEURS STANDARDS - BASIS FARBEN - BASIC COLORS

GS = SPECIAAL GEMOFFELD - LAQUE SPECIAL - SPECIALFARBE - SPECIAL COLOR

Z = ZWART - NOIR - SCHWARZ - BLACK











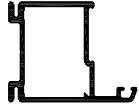

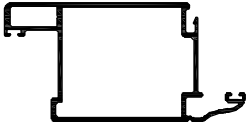

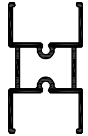
W = WIT - BLANC - WEISS - WHITE

De tekeningen die voorgesteld zijn op schaal 1:1, kunnen kleine maatafwijkingen vertonen, te wijten aan de reproductietechniek van deze catalogoog.

Les dessins représentés à l'échelle 1 peuvent avoir de légères variations dimensionnelles dues aux techniques de reproduction de ce catalogue.

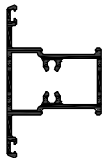
Die Zeichnungen im Maßstab 1:1 können aus technischen Reproduktionsgründen leichte Messungsschwankungen darstellen.

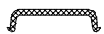
The drawings represented on a scale 1 basis may have light dimensional variations due to the reproduction of the manual.

NUMMER NUMERO NUMBER	AFBEELDING IMAGE BILD PICTURE	BLAD PAGE SEITE PAGE	OMTREK PERIM. UMRIB PERIM. mm	MECH. MEC. MEC. mm	lx (cm4)		ly (cm4)		LENGTE LONG. LANGE LENGTH	VERP. PER EMB. PAR PACK PR.	BR	AN	KL	GS	M1
					Wx (cm3)	Wy (cm3)	Wx (cm3)	Wy (cm3)							
AD010	 	5	246.9	119	8.84	8.28	3.74	2.49	6	2	X	X	X	X	
AD020	 	5	385.2	182	20.80	48.34	7.90	9.05	6	2	X	X	X	X	
AD030	 	6	277.7	130	4.03	5.54	2.58	2.01	6	2	X	X	X	X	
AD040	 	7	248.4	94	8.68	9.81	3.47	2.75	6	2	X	X	X	X	
AD060		6	103.3	31	-	-	-	-	6	6	X	X	X	X	
AD090		6	163.3	38	-	-	-	-	6	6	X	X	X	X	
AD130	 	8	241.7	99.1	7.22	7.16	2.93	2.22	6	2	X	X	X	X	
IP422		6	-	-	-	-	-	-	6,5	-	X				
UTL049		8	80	80	-	-	-	-	6	5	X	X	X	X	

BR = BRUT - BRUT - ROH - BRUT
 AN = ANODISATIE - ANODISE - ELOXIERT - ANODISED
 KL = STANDAARDKLEUREN - COULEUR STANDARD - BASIS FARBEN - BASIC COLORS
 GS = GEMOFFELD SPECIAAL - LAQUE SPECIAL - SPECIALFARBE - SPECIAL COLOR
 M1 = BICOLOR - BICOLOR - BICOLOR - BICOLOR

A = BUITEN - EXTERIEUR - AUSSEN - OUTSIDE
 B = BINNEN - INTERIEUR - INNEN - INSIDE

AD010

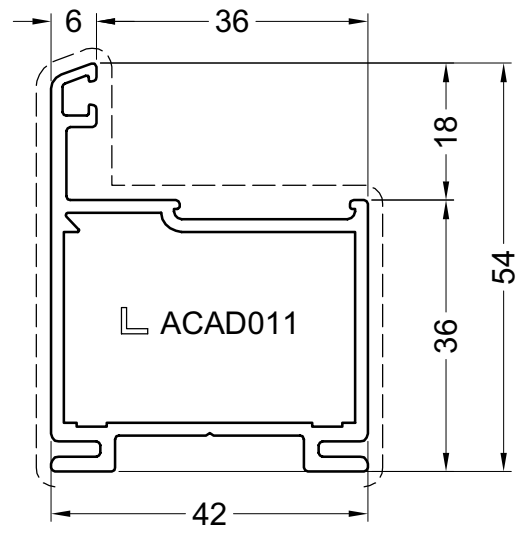

AD020

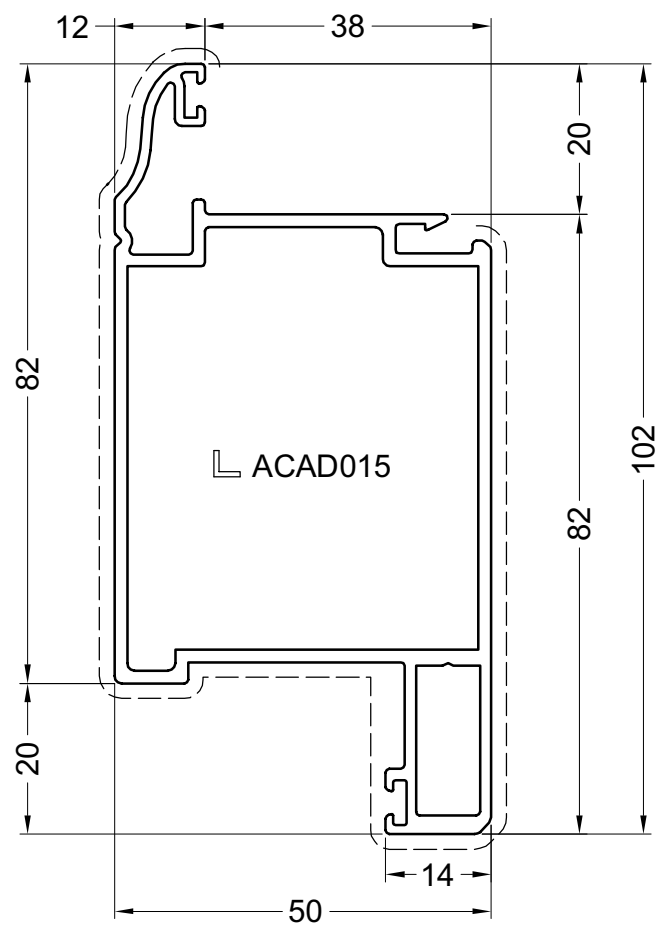

ada01

Primaire zichtbare zijde
Face visible primaire
Primär sichtbare Seite
Primary visible side

Secundaire zichtbare zijde
Face visible secondaire
Secondär sichtbare Seite
Secondary visible side

AD030

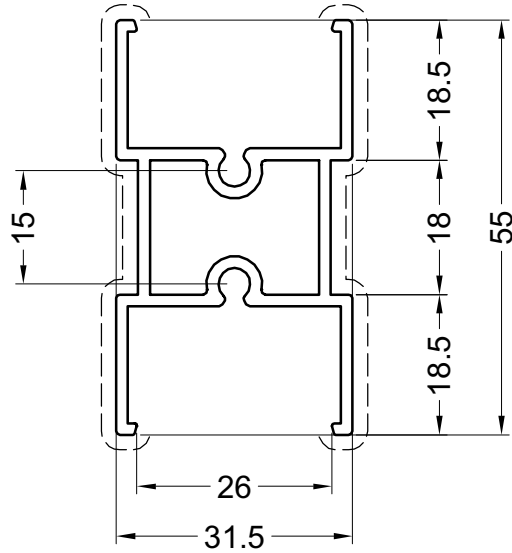

AD060

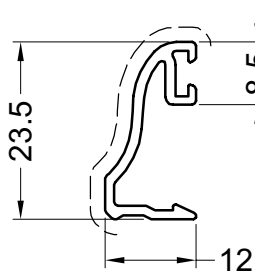

AD090

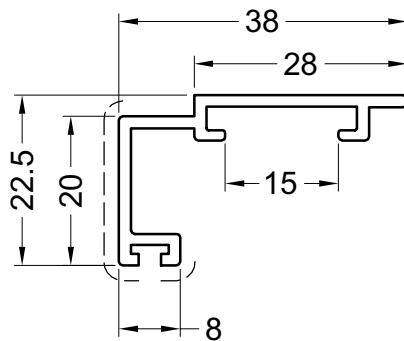

IP422

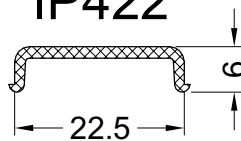

ada02

Primaire zichtbare zijde
Face visible primaire
Primär sichtbare Seite
Primary visible side

Secundaire zichtbare zijde
Face visible secondaire
Secondär sichtbare Seite
Secondary visible side

AD040

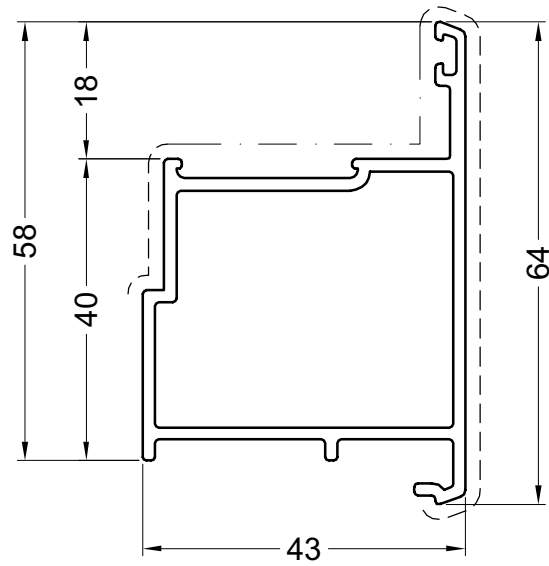

ada03

Primaire zichtbare zijde
Face visible primaire
Primär sichtbare Seite
Primary visible side

Secundaire zichtbare zijde
Face visible secondaire
Secondär sichtbare Seite
Secondary visible side



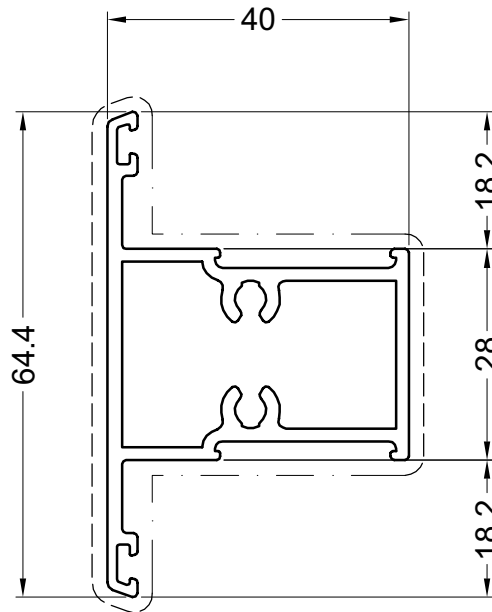

AD130

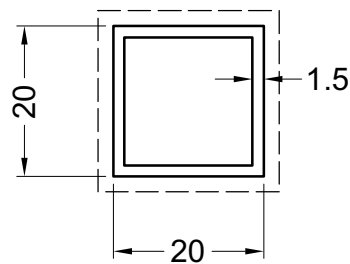

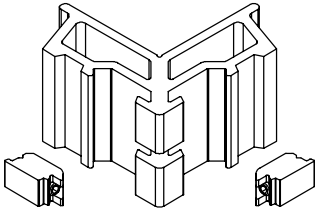

UTL049

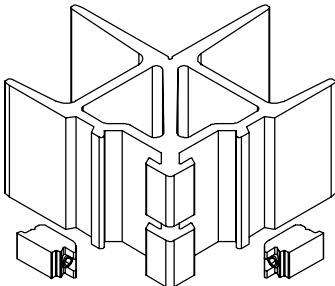

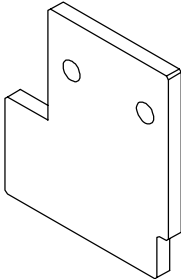
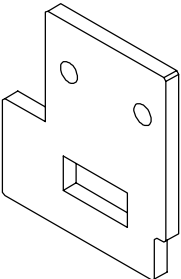
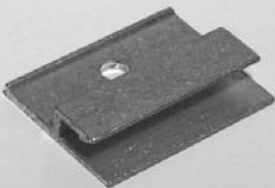

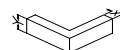
ada04

	Verp. per Emb. par Pack pr.	Einheid Unit	Toepassing Application	Kleur Couleur												
 <p>ACAD011 -Schroefhoek -Clame à visser -Eckverbinder Schraubbar -Square coupling joint</p> <p>X=25mm Y=38mm</p>  ACVG66	1	Stuk Pièce Stück Piece	AD010	<table border="1"> <tr><td>BR</td><td></td></tr> <tr><td>AN</td><td></td></tr> <tr><td>KL</td><td></td></tr> <tr><td>GS</td><td></td></tr> <tr><td>Z</td><td></td></tr> <tr><td>W</td><td></td></tr> </table>	BR		AN		KL		GS		Z		W	
BR																
AN																
KL																
GS																
Z																
W																
 <p>ACAD015 -Schroefhoek -Clame à visser -Eckverbinder Schraubbar -Square coupling joint</p> <p>X=50mm Y=46mm</p>  ACVG66	1	Stuk Pièce Stück Piece	AD020	<table border="1"> <tr><td>BR</td><td></td></tr> <tr><td>AN</td><td></td></tr> <tr><td>KL</td><td></td></tr> <tr><td>GS</td><td></td></tr> <tr><td>Z</td><td></td></tr> <tr><td>W</td><td></td></tr> </table>	BR		AN		KL		GS		Z		W	
BR																
AN																
KL																
GS																
Z																
W																
 <p>ACAD043 -Sluitstukje -Pièce d'étanchéité -Abschluss -Closer section</p>	1	Stuk Pièce Stück Piece	AD090	<table border="1"> <tr><td>BR</td><td></td></tr> <tr><td>AN</td><td></td></tr> <tr><td>KL</td><td></td></tr> <tr><td>GS</td><td></td></tr> <tr><td>Z</td><td></td></tr> <tr><td>W</td><td></td></tr> </table>	BR		AN		KL		GS		Z		W	
BR																
AN																
KL																
GS																
Z																
W																
 <p>ACAD044 -Sluitstukje -Pièce d'étanchéité -Abschluss -Closer section</p>	1	Stuk Pièce Stück Piece	AD090 ACIP146 ACIP147 ACIP148 ACIP149	<table border="1"> <tr><td>BR</td><td></td></tr> <tr><td>AN</td><td></td></tr> <tr><td>KL</td><td></td></tr> <tr><td>GS</td><td></td></tr> <tr><td>Z</td><td></td></tr> <tr><td>W</td><td></td></tr> </table>	BR		AN		KL		GS		Z		W	
BR																
AN																
KL																
GS																
Z																
W																
 <p>ACAD060 -Klemstuk glaslat -Clips pour latte a vitrage -Befestigungsklotz für glasleiste -Clip for glazing bead</p>	1	Stuk Pièce Stück Piece	AD060	<table border="1"> <tr><td>BR</td><td></td></tr> <tr><td>AN</td><td></td></tr> <tr><td>KL</td><td></td></tr> <tr><td>GS</td><td></td></tr> <tr><td>Z</td><td></td></tr> <tr><td>W</td><td></td></tr> </table>	BR		AN		KL		GS		Z		W	
BR																
AN																
KL																
GS																
Z																
W																









		Verp. per Emb. par Pack pr. Pack pr.	Eenheid Unité Einheit Unit	Toepassing Application Anwendung Application	Kleur Couleur Farbe Color												
	ACAD100 -Scharnier -Charnière -Scharnier -Hinge	1	Stuk Pièce Stück Pièce		<table border="1"> <tr><td>BR</td><td></td></tr> <tr><td>AN</td><td></td></tr> <tr><td>KL</td><td></td></tr> <tr><td>GS</td><td></td></tr> <tr><td>Z</td><td></td></tr> <tr><td>W</td><td></td></tr> </table>	BR		AN		KL		GS		Z		W	
BR																	
AN																	
KL																	
GS																	
Z																	
W																	
	ACAD101 -Afdekkap PVC voor scharnier -Capuchon PVC pour charnière -Abdeckkappe PVC für Scharnier -PVC cap for hinge	1	Stuk Pièce Stück Pièce		<table border="1"> <tr><td>BR</td><td></td></tr> <tr><td>AN</td><td>X</td></tr> <tr><td>KL</td><td></td></tr> <tr><td>GS</td><td></td></tr> <tr><td>Z</td><td>X</td></tr> <tr><td>W</td><td>X</td></tr> </table>	BR		AN	X	KL		GS		Z	X	W	X
BR																	
AN	X																
KL																	
GS																	
Z	X																
W	X																
	ACAD102 -Messing afdekkap met sierknop voor scharnier -Capuchon laiton pour charnière -Messing abdeckkappe für Scharnier -Cap brass for hinge	1	Stuk Pièce Stück Pièce		<table border="1"> <tr><td>BR</td><td></td></tr> <tr><td>AN</td><td></td></tr> <tr><td>KL</td><td></td></tr> <tr><td>GS</td><td></td></tr> <tr><td>Z</td><td></td></tr> <tr><td>W</td><td></td></tr> </table>	BR		AN		KL		GS		Z		W	
BR																	
AN																	
KL																	
GS																	
Z																	
W																	
	ACAD105 -Slot -Serrure -Schloss -Lock	1	Stuk Pièce Stück Pièce	AD020	<table border="1"> <tr><td>BR</td><td></td></tr> <tr><td>AN</td><td></td></tr> <tr><td>KL</td><td></td></tr> <tr><td>GS</td><td></td></tr> <tr><td>Z</td><td></td></tr> <tr><td>W</td><td></td></tr> </table>	BR		AN		KL		GS		Z		W	
BR																	
AN																	
KL																	
GS																	
Z																	
W																	
	ACAD110 -Slotplaat -Gache -Schliessplatte -Lock plate	1	Stuk Pièce Stück Pièce	AD010 ACAD105	<table border="1"> <tr><td>BR</td><td></td></tr> <tr><td>AN</td><td></td></tr> <tr><td>KL</td><td></td></tr> <tr><td>GS</td><td></td></tr> <tr><td>Z</td><td></td></tr> <tr><td>W</td><td></td></tr> </table>	BR		AN		KL		GS		Z		W	
BR																	
AN																	
KL																	
GS																	
Z																	
W																	

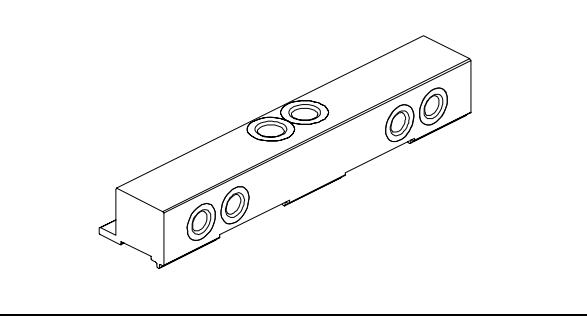



BR = BRUT - BRUT - ROH - BRUT
 AN (X) = ANODISATIE - ANODISE - ELOXIERT - ANODISED
 AN (■) = GELAKT - LAQUE - LACKIERT - LACQUERED -- RAL9006M
 KL = STANDAARDKLEUREN - COULEUR STANDARD - BASIS FARBEN - BASIC COLORS
 GS = GEMOFFELD SPECIAAL - LAQUE SPECIAL - SPECIALFARBE - SPECIAL COLOR
 Z = ZWART - NOIR - SCHWARZ - BLACK
 W = WIT - BLANC - WEISS - WHITE

 GEREEDSCHAP - OUTILLAGE
 WERKZEUG - TOOL
 BEVESTIGING - FIXATION
 BEFESTIGUNG - FIXATION

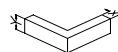

		Verp. per Emb. par Pack pr.	Einheid Unité Einheit Unit	Toepassing Application Anwendung Application	Kleur Couleur Farbe Color												
	<p>ACAD430</p> <ul style="list-style-type: none"> -Deurgrendel -Verrou porte -Tür Kantriegel -Extended bolt 	1	Stuk Pièce Stück Piece	AD040	<table border="1"> <tr><td>BR</td><td></td></tr> <tr><td>AN</td><td></td></tr> <tr><td>KL</td><td></td></tr> <tr><td>GS</td><td></td></tr> <tr><td>Z</td><td>X</td></tr> <tr><td>W</td><td></td></tr> </table>	BR		AN		KL		GS		Z	X	W	
BR																	
AN																	
KL																	
GS																	
Z	X																
W																	
	<p>ACAD902</p> <ul style="list-style-type: none"> -Boormal -Calibre -Bohrschablone -Boring jig set <p> Ø6.7 + Ø10</p>	1	Stuk Pièce Stück Piece	ACAD100	<table border="1"> <tr><td>BR</td><td></td></tr> <tr><td>AN</td><td></td></tr> <tr><td>KL</td><td></td></tr> <tr><td>GS</td><td></td></tr> <tr><td>Z</td><td></td></tr> <tr><td>W</td><td></td></tr> </table>	BR		AN		KL		GS		Z		W	
BR																	
AN																	
KL																	
GS																	
Z																	
W																	
	<p>ACAD903</p> <ul style="list-style-type: none"> -Boormal voor T-verbinding -Calibre pour assemblage T -Bohrschablone für T-Verbindung -Boring jig set for connection T <p> Ø5 + Ø10</p>	1	Stuk Pièce Stück Piece	AD020 AD030	<table border="1"> <tr><td>BR</td><td></td></tr> <tr><td>AN</td><td></td></tr> <tr><td>KL</td><td></td></tr> <tr><td>GS</td><td></td></tr> <tr><td>Z</td><td></td></tr> <tr><td>W</td><td></td></tr> </table>	BR		AN		KL		GS		Z		W	
BR																	
AN																	
KL																	
GS																	
Z																	
W																	
	<p>ACDR050</p> <ul style="list-style-type: none"> -Inox schroef DIN7981 4.8x32 -Vis en inox DIN7981 4.8x32 -Inox Schraube DIN7981 4.8x32 -Stainless steel screw DIN7981 4.8x32 	200	Stuks Pièces Stücke Pieces	AD130	<table border="1"> <tr><td>BR</td><td></td></tr> <tr><td>AN</td><td></td></tr> <tr><td>KL</td><td></td></tr> <tr><td>GS</td><td></td></tr> <tr><td>Z</td><td></td></tr> <tr><td>W</td><td></td></tr> </table>	BR		AN		KL		GS		Z		W	
BR																	
AN																	
KL																	
GS																	
Z																	
W																	
	<p>ACIP146</p> <ul style="list-style-type: none"> -Automatische tochtfluiser 710mm -Joint bas de porte automatique 710mm -Automatische türdichtung 710mm -Self operating threshold 710mm 	1	Stuk Pièce Stück Piece	AD090	<table border="1"> <tr><td>BR</td><td></td></tr> <tr><td>AN</td><td></td></tr> <tr><td>KL</td><td></td></tr> <tr><td>GS</td><td></td></tr> <tr><td>Z</td><td></td></tr> <tr><td>W</td><td></td></tr> </table>	BR		AN		KL		GS		Z		W	
BR																	
AN																	
KL																	
GS																	
Z																	
W																	

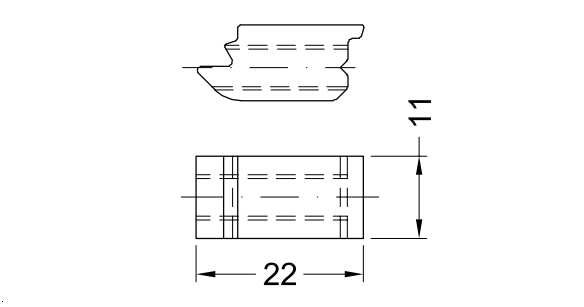

	Verp. per Emb. par Pack pr. Pack pr.	Eenheid Unité Einheit Unit	Toepassing Application Anwendung Application	Kleur Couleur Farbe Color												
 <p>ACIP147 -Automatische tochttafsluiter 835mm -Joint bas de porte automatique 835mm -Automatische türdichtung 835mm -Self operating threshold 835mm</p>	1	Stuk Pièce Stück Pièce	AD090	<table border="1"> <tr><td>BR</td><td></td></tr> <tr><td>AN</td><td></td></tr> <tr><td>KL</td><td></td></tr> <tr><td>GS</td><td></td></tr> <tr><td>Z</td><td></td></tr> <tr><td>W</td><td></td></tr> </table>	BR		AN		KL		GS		Z		W	
BR																
AN																
KL																
GS																
Z																
W																
 <p>ACIP148 -Automatische tochttafsluiter 960mm -Joint bas de porte automatique 960mm -Automatische türdichtung 960mm -Self operating threshold 960mm</p>	1	Stuk Pièce Stück Pièce	AD090	<table border="1"> <tr><td>BR</td><td></td></tr> <tr><td>AN</td><td></td></tr> <tr><td>KL</td><td></td></tr> <tr><td>GS</td><td></td></tr> <tr><td>Z</td><td></td></tr> <tr><td>W</td><td></td></tr> </table>	BR		AN		KL		GS		Z		W	
BR																
AN																
KL																
GS																
Z																
W																
 <p>ACIP149 -Automatische tochttafsluiter 1085mm -Joint bas de porte automatique 1085mm -Automatische türdichtung 1085mm -Self operating threshold 1085mm</p>	1	Stuk Pièce Stück Pièce	AD090	<table border="1"> <tr><td>BR</td><td></td></tr> <tr><td>AN</td><td></td></tr> <tr><td>KL</td><td></td></tr> <tr><td>GS</td><td></td></tr> <tr><td>Z</td><td></td></tr> <tr><td>W</td><td></td></tr> </table>	BR		AN		KL		GS		Z		W	
BR																
AN																
KL																
GS																
Z																
W																
 <p>ACIP427 -Bodemhuls verzinkt -Boîte de sol -Bodenbushese verzinkt -Grondsleeve zinc-plate</p>	1	Stuk Pièce Stück Pièce		<table border="1"> <tr><td>BR</td><td></td></tr> <tr><td>AN</td><td></td></tr> <tr><td>KL</td><td></td></tr> <tr><td>GS</td><td></td></tr> <tr><td>Z</td><td></td></tr> <tr><td>W</td><td></td></tr> </table>	BR		AN		KL		GS		Z		W	
BR																
AN																
KL																
GS																
Z																
W																
 <p>ACMX853 -Schroefblokje 11mm -Clavet 11mm -Schraubeblock 11mm -Cleat tensioning block 11mm</p>	48	Stuk Pièce Stück Pièce		<table border="1"> <tr><td>BR</td><td></td></tr> <tr><td>AN</td><td></td></tr> <tr><td>KL</td><td></td></tr> <tr><td>GS</td><td></td></tr> <tr><td>Z</td><td></td></tr> <tr><td>W</td><td></td></tr> </table>	BR		AN		KL		GS		Z		W	
BR																
AN																
KL																
GS																
Z																
W																

BR = BRUT - BRUT - ROH - BRUT
AN (X) = ANODISATIE - ANODISE - ELOXIERT - ANODISED
AN (■) = GELAKT - LAQUE - LACKIERT - LACQUERED -- RAL9006M
KL = STANDAARDKLEUREN - COULEUR STANDARD - BASIS FARBEN - BASIC COLORS
GS = GEMOFFELD SPECIAAL - LAQUE SPECIAL - SPECIALFARBE - SPECIAL COLOR
Z = ZWART - NOIR - SCHWARZ - BLACK
W = WIT - BLANC - WEISS - WHITE



GEREEDSCHAP - OUTILLAGE
WERKZEUG - TOOL





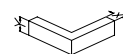

BEVESTIGING - FIXATION
BEFESTIGUNG - FIXATION



		Verp. per Emb. par Pack pr.	Einheid Unité Einheit Unit	Toepassing Application Anwendung Application	Kleur Couleur Farbe Color												
	<p>ACSH033</p> <ul style="list-style-type: none"> -Borsteldichting deur -Brosse pour porte -Burstendichtung für Türen -Brush fitting for doors 	50	m	AD090	<table border="1"> <tr><td>BR</td><td></td></tr> <tr><td>AN</td><td></td></tr> <tr><td>KL</td><td></td></tr> <tr><td>GS</td><td></td></tr> <tr><td>Z</td><td></td></tr> <tr><td>W</td><td></td></tr> </table>	BR		AN		KL		GS		Z		W	
BR																	
AN																	
KL																	
GS																	
Z																	
W																	
	<p>ACSIL04</p> <ul style="list-style-type: none"> -Afdichtingslijmkit voor versteknaden -Joint d'étanchéité pour onglets -Leim für abdichtung -Sealingglue 	1	Stuk Pièce Stück Pièce	AD010 AD020	<table border="1"> <tr><td>BR</td><td></td></tr> <tr><td>AN</td><td></td></tr> <tr><td>KL</td><td></td></tr> <tr><td>GS</td><td></td></tr> <tr><td>Z</td><td>X</td></tr> <tr><td>W</td><td>X</td></tr> </table>	BR		AN		KL		GS		Z	X	W	X
BR																	
AN																	
KL																	
GS																	
Z	X																
W	X																
	<p>ACSIL08</p> <ul style="list-style-type: none"> -Siliconenpomp -Pistolet doseur pour les tubes silicones -Handkartuschenpistole für die verarbeitung von silikone und leime -Silicone gun 	1	Stuk Pièce Stück Pièce	AD010 AD020	<table border="1"> <tr><td>BR</td><td></td></tr> <tr><td>AN</td><td></td></tr> <tr><td>KL</td><td></td></tr> <tr><td>GS</td><td></td></tr> <tr><td>Z</td><td></td></tr> <tr><td>W</td><td></td></tr> </table>	BR		AN		KL		GS		Z		W	
BR																	
AN																	
KL																	
GS																	
Z																	
W																	
	<p>ACSIL013</p> <ul style="list-style-type: none"> -Lijm voor verstekhoek -Colle pour onglet -Kleber für gehrung -Glue for mitre 	1	Stuk Pièce Stück Pièce	AD010 AD020	<table border="1"> <tr><td>BR</td><td></td></tr> <tr><td>AN</td><td></td></tr> <tr><td>KL</td><td></td></tr> <tr><td>GS</td><td></td></tr> <tr><td>Z</td><td></td></tr> <tr><td>W</td><td></td></tr> </table>	BR		AN		KL		GS		Z		W	
BR																	
AN																	
KL																	
GS																	
Z																	
W																	
	<p>ACVG31</p> <ul style="list-style-type: none"> -Beglazingsrubber buiten 3mm -Joint de vitrage extérieure 3mm -Glasanlage-dichtung 3mm -Glazing gasket outside 3mm 	200	m	AD020	<table border="1"> <tr><td>BR</td><td></td></tr> <tr><td>AN</td><td></td></tr> <tr><td>KL</td><td></td></tr> <tr><td>GS</td><td></td></tr> <tr><td>Z</td><td></td></tr> <tr><td>W</td><td></td></tr> </table>	BR		AN		KL		GS		Z		W	
BR																	
AN																	
KL																	
GS																	
Z																	
W																	



		Verp. per Emb. par Pack pr. Pack pr.	Eenheid Unité Einheit Unit	Toepassing Application Anwendung Application	Kleur Couleur Farbe Color												
	ACVG31N -Beglazingsrubber buiten 3mm buitendraaiend -Joint de vitrage extérieur 3mm tournant -Glasanlage-dichtung 3mm herumdrehend -Glazing gasket outside 3mm rotated	200	m	AD020	<table border="1"> <tr><td>BR</td><td></td></tr> <tr><td>AN</td><td></td></tr> <tr><td>KL</td><td></td></tr> <tr><td>GS</td><td></td></tr> <tr><td>Z</td><td></td></tr> <tr><td>W</td><td></td></tr> </table>	BR		AN		KL		GS		Z		W	
BR																	
AN																	
KL																	
GS																	
Z																	
W																	
	ACVG32 -Beglazingsrubber 3mm -Joint de vitrage 3mm -Glasdichtung 3mm -Glazing gasket 3mm	100	m	AD060	<table border="1"> <tr><td>BR</td><td></td></tr> <tr><td>AN</td><td></td></tr> <tr><td>KL</td><td></td></tr> <tr><td>GS</td><td></td></tr> <tr><td>Z</td><td></td></tr> <tr><td>W</td><td></td></tr> </table>	BR		AN		KL		GS		Z		W	
BR																	
AN																	
KL																	
GS																	
Z																	
W																	
	ACVG32N -Beglazingsrubber 3mm ronddraaiend -Joint de vitrage 3mm tournant -Glasdichtung 3mm herumdrehend -Glazing gasket 3mm rotated	100	m	AD060	<table border="1"> <tr><td>BR</td><td></td></tr> <tr><td>AN</td><td></td></tr> <tr><td>KL</td><td></td></tr> <tr><td>GS</td><td></td></tr> <tr><td>Z</td><td></td></tr> <tr><td>W</td><td></td></tr> </table>	BR		AN		KL		GS		Z		W	
BR																	
AN																	
KL																	
GS																	
Z																	
W																	
	ACVG33 -Beglazingsrubber 4mm -Joint de vitrage 4mm -Glasdichtung 4mm -Glazing gasket 4mm	100	m	AD060	<table border="1"> <tr><td>BR</td><td></td></tr> <tr><td>AN</td><td></td></tr> <tr><td>KL</td><td></td></tr> <tr><td>GS</td><td></td></tr> <tr><td>Z</td><td></td></tr> <tr><td>W</td><td></td></tr> </table>	BR		AN		KL		GS		Z		W	
BR																	
AN																	
KL																	
GS																	
Z																	
W																	
	ACVG33N -Beglazingsrubber 4mm ronddraaiend -Joint de vitrage 4mm tournant -Glasdichtung 4mm herumdrehend -Glazing gasket 4mm rotated	100	m	AD060	<table border="1"> <tr><td>BR</td><td></td></tr> <tr><td>AN</td><td></td></tr> <tr><td>KL</td><td></td></tr> <tr><td>GS</td><td></td></tr> <tr><td>Z</td><td></td></tr> <tr><td>W</td><td></td></tr> </table>	BR		AN		KL		GS		Z		W	
BR																	
AN																	
KL																	
GS																	
Z																	
W																	

BR = BRUT - BRUT - ROH - BRUT
 AN (X) = ANODISATIE - ANODISE - ELOXIERT - ANODISED
 AN (■) = GELAKT - LAQUE - LACKIERT - LACQUERED -- RAL9006M
 KL = STANDAARDKLEUREN - COULEUR STANDARD - BASIS FARBEN - BASIC COLORS
 GS = GEMOFFELD SPECIAAL - LAQUE SPECIAL - SPECIALFARBE - SPECIAL COLOR
 Z = ZWART - NOIR - SCHWARZ - BLACK
 W = WIT - BLANC - WEISS - WHITE



GEREEDSCHAP - OUTILLAGE
WERKZEUG - TOOL



BEVESTIGING - FIXATION
BEFESTIGUNG - FIXATION

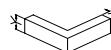

		Verp. per Emb. par Pack pr.	Einheid Unité Einheit Unit	Toepassing Application Anwendung Application	Kleur Couleur Farbe Color												
	ACVG34 -Beglazingsrubber 5mm -Joint de vitrage 5mm -Glasdichtung 5mm -Glazing gasket 5mm	100	m	AD060	<table border="1"> <tr><td>BR</td><td></td></tr> <tr><td>AN</td><td></td></tr> <tr><td>KL</td><td></td></tr> <tr><td>GS</td><td></td></tr> <tr><td>Z</td><td></td></tr> <tr><td>W</td><td></td></tr> </table>	BR		AN		KL		GS		Z		W	
BR																	
AN																	
KL																	
GS																	
Z																	
W																	
	ACVG34N -Beglazingsrubber 5mm ronddraaiend -Joint de vitrage 5mm tournant -Glasdichtung 5mm herumdrehend -Glazing gasket 5mm rotated	100	m	AD060	<table border="1"> <tr><td>BR</td><td></td></tr> <tr><td>AN</td><td></td></tr> <tr><td>KL</td><td></td></tr> <tr><td>GS</td><td></td></tr> <tr><td>Z</td><td></td></tr> <tr><td>W</td><td></td></tr> </table>	BR		AN		KL		GS		Z		W	
BR																	
AN																	
KL																	
GS																	
Z																	
W																	
	ACVG66 -Zeskantsleutel 3mm -Clé à six pans 3mm -Sechskantschlüssel 3mm -T-handle hexagon-key 3mm	1	Stuk Pièce Stück Piece	ACAD011 ACAD015	<table border="1"> <tr><td>BR</td><td></td></tr> <tr><td>AN</td><td></td></tr> <tr><td>KL</td><td></td></tr> <tr><td>GS</td><td></td></tr> <tr><td>Z</td><td></td></tr> <tr><td>W</td><td></td></tr> </table>	BR		AN		KL		GS		Z		W	
BR																	
AN																	
KL																	
GS																	
Z																	
W																	
	ACVG131 -Beglazingsrubber buiten 4mm -Joint de vitrage extérieur 4mm -Glasanlage-dichtung 4mm -Glazing gasket outside 4mm	100	m	AD020	<table border="1"> <tr><td>BR</td><td></td></tr> <tr><td>AN</td><td></td></tr> <tr><td>KL</td><td></td></tr> <tr><td>GS</td><td></td></tr> <tr><td>Z</td><td></td></tr> <tr><td>W</td><td></td></tr> </table>	BR		AN		KL		GS		Z		W	
BR																	
AN																	
KL																	
GS																	
Z																	
W																	
	ACVG131N -Beglazingsrubber buiten 4mm ronddraaiend -Joint de vitrage extérieur 4mm tournant -Glasanlage-dichtung 4mm herumdrehend -Glazing gasket outside 4mm rotated	100	m	AD020	<table border="1"> <tr><td>BR</td><td></td></tr> <tr><td>AN</td><td></td></tr> <tr><td>KL</td><td></td></tr> <tr><td>GS</td><td></td></tr> <tr><td>Z</td><td></td></tr> <tr><td>W</td><td></td></tr> </table>	BR		AN		KL		GS		Z		W	
BR																	
AN																	
KL																	
GS																	
Z																	
W																	

BR = BRUT - BRUT - ROH - BRUT
 AN (X) = ANODISATIE - ANODISE - ELOXIERT - ANODISED
 AN (■) = GELAKT - LAQUE - LACKIERT - LACQUERED -- RAL9006M
 KL = STANDAARDKLEUREN - COULEUR STANDARD - BASIS FARBEN - BASIC COLORS
 GS = GEMOFFELD SPECIAAL - LAQUE SPECIAL - SPECIALFARBE - SPECIAL COLOR
 Z = ZWART - NOIR - SCHWARZ - BLACK
 W = WIT - BLANC - WEISS - WHITE







GEREEDSCHAP - OUTILLAGE
WERKZEUG - TOOL

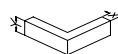

BEVESTIGING - FIXATION
BEFESTIGUNG - FIXATION

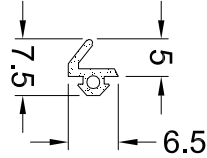

		Verp. per Emb. par Pack pr. Pack pr.	Eenheid Unité Einheit Unit	Toepassing Application Anwendung Application	Kleur Couleur Farbe Color												
	ACVG231 -Beglazingsrubber buiten 2mm -Joint de vitrage extérieur 2mm -Glasanlage-dichtung 2mm -Glazing gasket outside 2mm	200	m	AD020	<table border="1"> <tr><td>BR</td><td></td></tr> <tr><td>AN</td><td></td></tr> <tr><td>KL</td><td></td></tr> <tr><td>GS</td><td></td></tr> <tr><td>Z</td><td></td></tr> <tr><td>W</td><td></td></tr> </table>	BR		AN		KL		GS		Z		W	
BR																	
AN																	
KL																	
GS																	
Z																	
W																	
	ACVG231N -Beglazingsrubber buiten 2mm ronddraaiend -Joint de vitrage extérieur 2mm tournant -Glasanlage-dichtung 2mm herumdrehend -Glazing gasket outside 2mm rotated	200	m	AD020	<table border="1"> <tr><td>BR</td><td></td></tr> <tr><td>AN</td><td></td></tr> <tr><td>KL</td><td></td></tr> <tr><td>GS</td><td></td></tr> <tr><td>Z</td><td></td></tr> <tr><td>W</td><td></td></tr> </table>	BR		AN		KL		GS		Z		W	
BR																	
AN																	
KL																	
GS																	
Z																	
W																	
	ACVG340 -Beglazingsrubber 6mm -Joint de vitrage 6mm -Glasdichtung 6mm -Glazing gasket 6mm	200	m	AD060	<table border="1"> <tr><td>BR</td><td></td></tr> <tr><td>AN</td><td></td></tr> <tr><td>KL</td><td></td></tr> <tr><td>GS</td><td></td></tr> <tr><td>Z</td><td></td></tr> <tr><td>W</td><td></td></tr> </table>	BR		AN		KL		GS		Z		W	
BR																	
AN																	
KL																	
GS																	
Z																	
W																	
	ACVG340N -Beglazingsrubber 6mm ronddraaiend -Joint de vitrage 6mm tournant -Glasdichtung 6mm herumdrehend -Glazing gasket 6mm rotated	100	m	AD060	<table border="1"> <tr><td>BR</td><td></td></tr> <tr><td>AN</td><td></td></tr> <tr><td>KL</td><td></td></tr> <tr><td>GS</td><td></td></tr> <tr><td>Z</td><td></td></tr> <tr><td>W</td><td></td></tr> </table>	BR		AN		KL		GS		Z		W	
BR																	
AN																	
KL																	
GS																	
Z																	
W																	
	ACVL032 -Aanslagdichting deuren -Joint pour portes -Flügeldichtung Türen -Gasket for doors	100	m	AD010 AD020	<table border="1"> <tr><td>BR</td><td></td></tr> <tr><td>AN</td><td></td></tr> <tr><td>KL</td><td></td></tr> <tr><td>GS</td><td></td></tr> <tr><td>Z</td><td></td></tr> <tr><td>W</td><td></td></tr> </table>	BR		AN		KL		GS		Z		W	
BR																	
AN																	
KL																	
GS																	
Z																	
W																	

BR = BRUT - BRUT - ROH - BRUT
AN (X) = ANODISATIE - ANODISE - ELOXIERT - ANODISED
AN (■) = GELAKT - LAQUE - LACKIERT - LACQUERED -- RAL9006M
KL = STANDAARDKLEUREN - COULEUR STANDARD - BASIS FARBEN - BASIC COLORS
GS = GEMOFFELD SPECIAAL - LAQUE SPECIAL - SPECIALFARBEN - SPECIAL COLOR
Z = ZWART - NOIR - SCHWARZ - BLACK
W = WIT - BLANC - WEISS - WHITE



GEREEDSCHAP - OUTILLAGE
WERKZEUG - TOOL



BEVESTIGING - FIXATION
BEFESTIGUNG - FIXATION

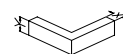

	Verp. per Emb. par Pack pr.	Einheid Unité Einheit Unit	Toepassing Application Anwendung Application	Kleur Couleur Farbe Color												
 <p>ACVL032N -Aanslagdichting deuren ronddraaiend -Joint pour portes tournant -Flügelichtung Türen herumdrehend -Gasket for doors rotated</p>	100	m	AD010 AD020	<table border="1"> <tr><td>BR</td><td></td></tr> <tr><td>AN</td><td></td></tr> <tr><td>KL</td><td></td></tr> <tr><td>GS</td><td></td></tr> <tr><td>Z</td><td></td></tr> <tr><td>W</td><td></td></tr> </table>	BR		AN		KL		GS		Z		W	
BR																
AN																
KL																
GS																
Z																
W																

BR = BRUT - BRUT - ROH - BRUT
 AN (X) = ANODISATIE - ANODISE - ELOXIERT - ANODISED
 AN (■) = GELAKT - LAQUE - LACKIERT - LACQUERED -- RAL9006M
 KL = STANDAARDKLEUREN - COULEUR STANDARD - BASIS FARBEN - BASIC COLORS
 GS = GEMOFFELD SPECIAAL - LAQUE SPECIAL - SPECIALFARBE - SPECIAL COLOR
 Z = ZWART - NOIR - SCHWARZ - BLACK
 W = WIT - BLANC - WEISS - WHITE



GEREEDSCHAP - OUTILLAGE
 WERKZEUG - TOOL



BEVESTIGING - FIXATION
 BEFESTIGUNG - FIXATION

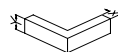

DOORSNEDE - COUPE - SCHNITT - SECTION

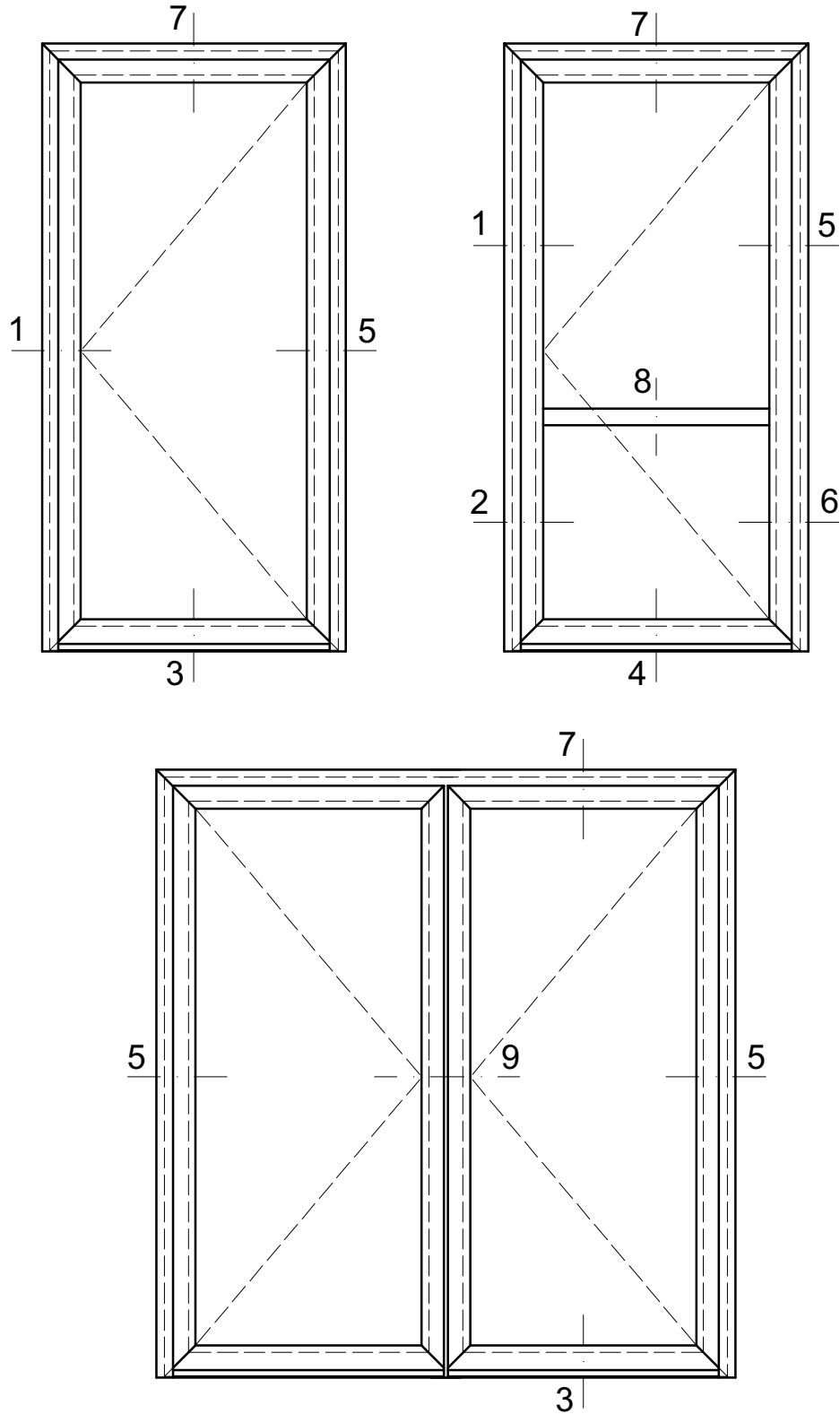

overz

DOORSNEDE - COUPE - SCHNITT - SECTION

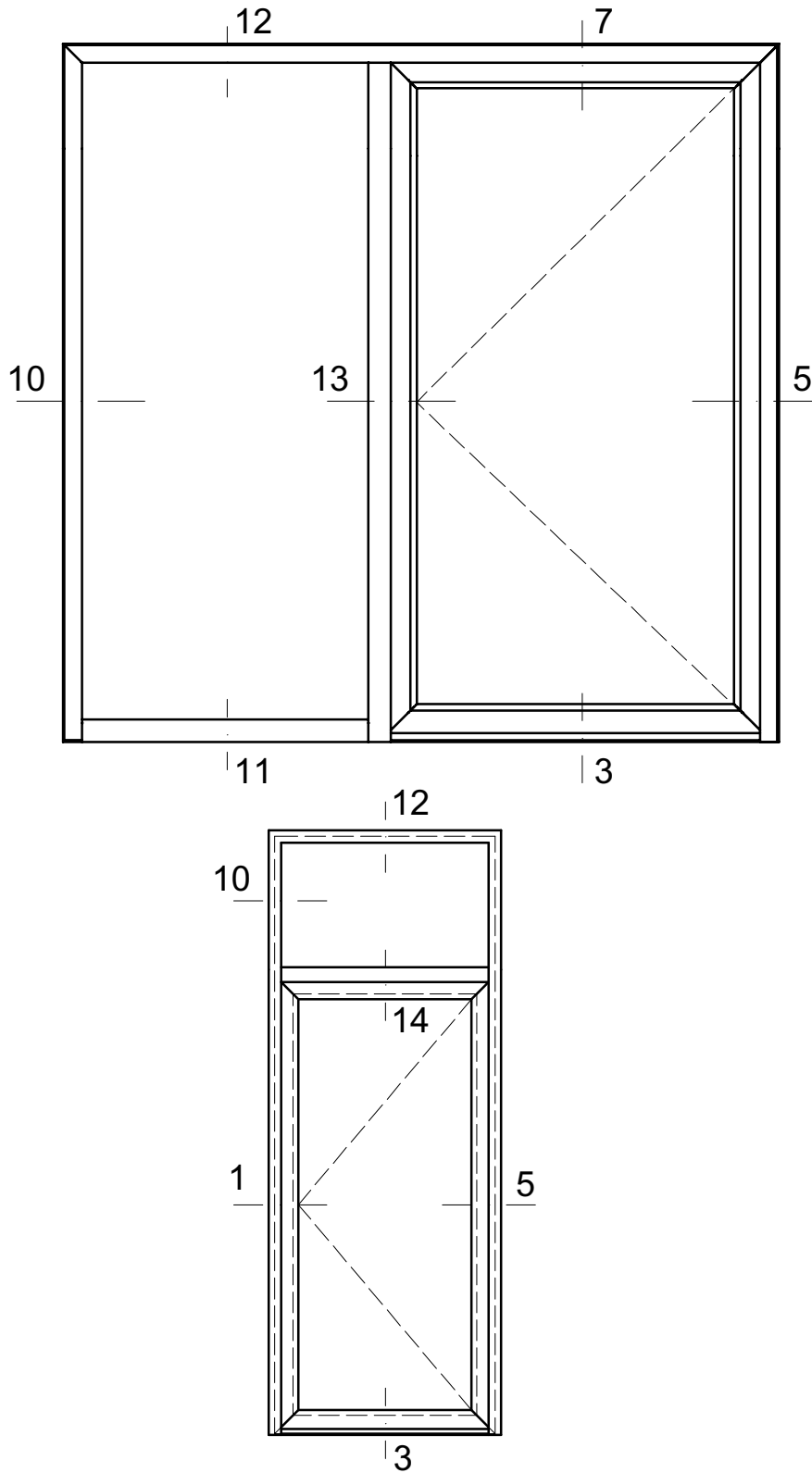

OVERZ1

1

DOORSNEDE - COUPE - SCHNITT - SECTION

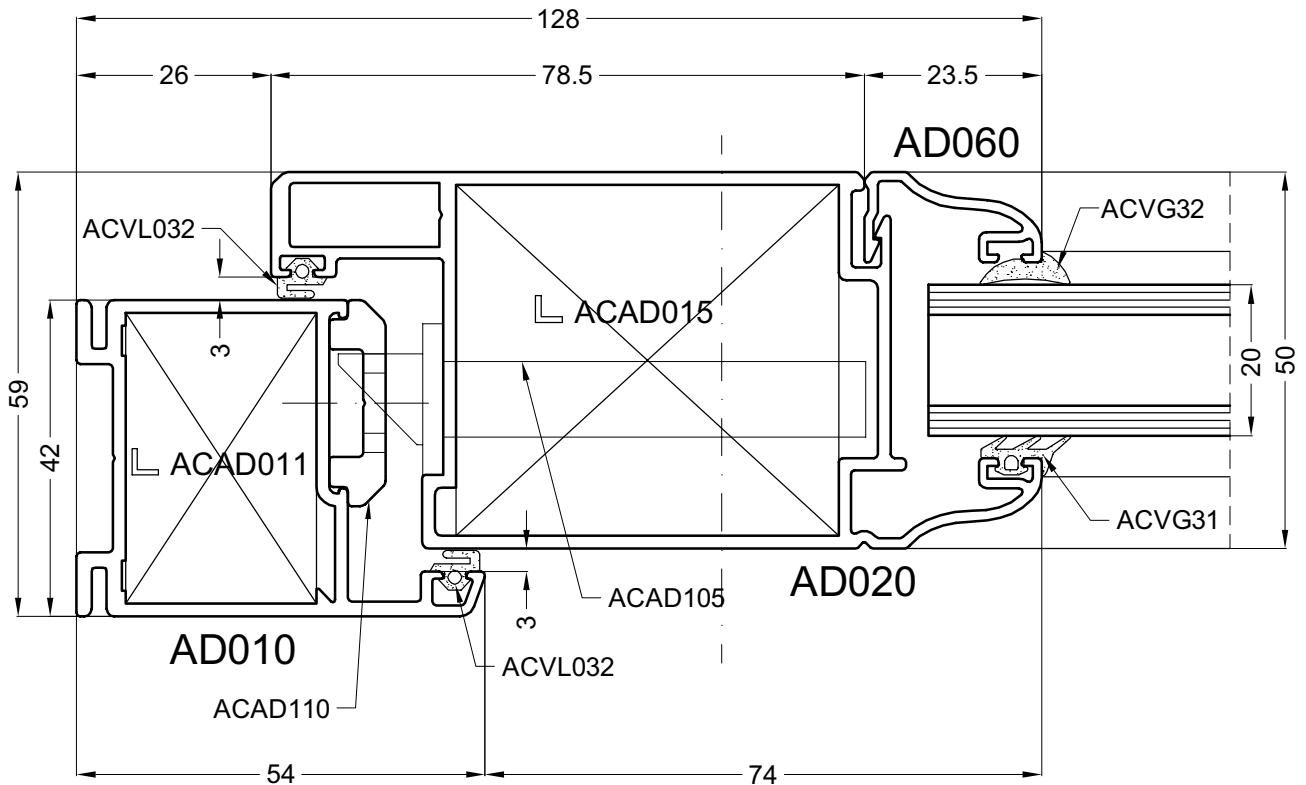
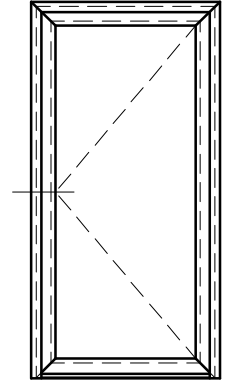

door1

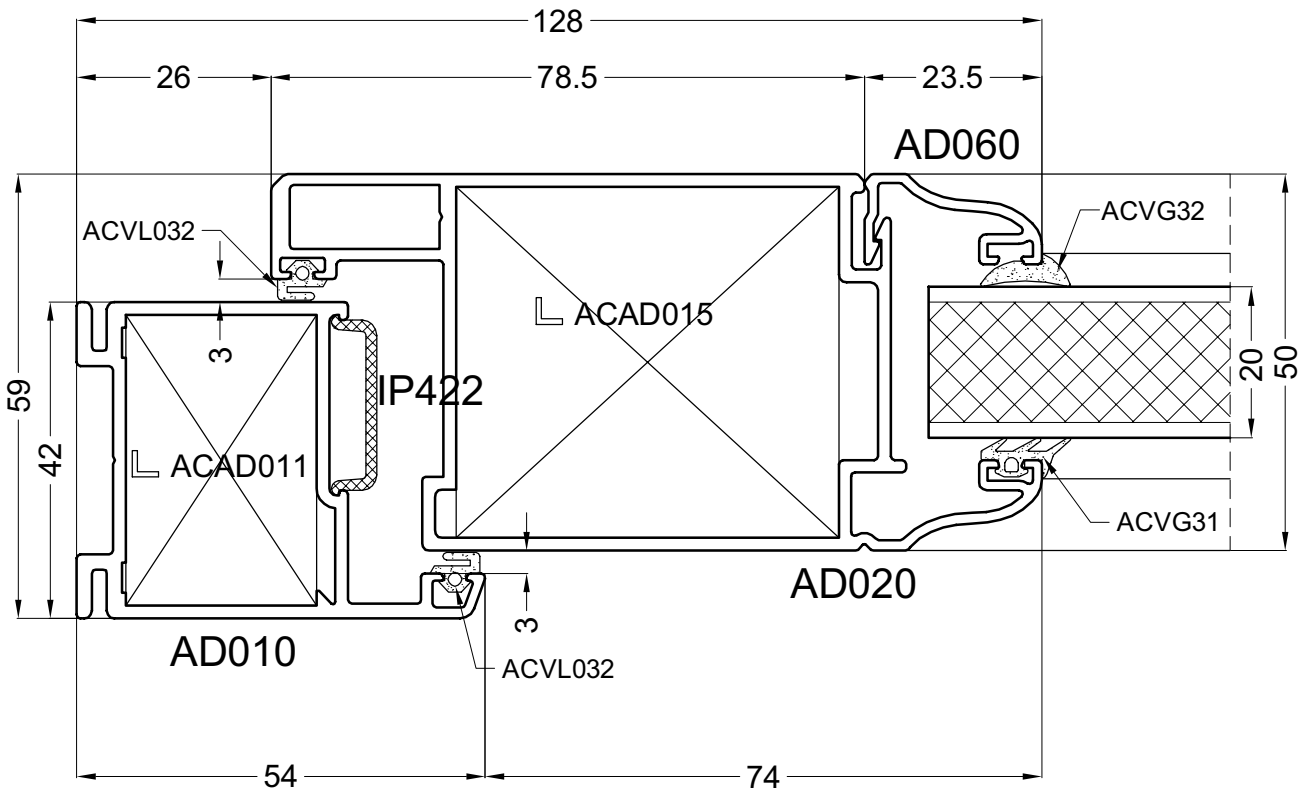
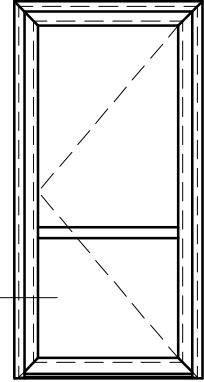

door2

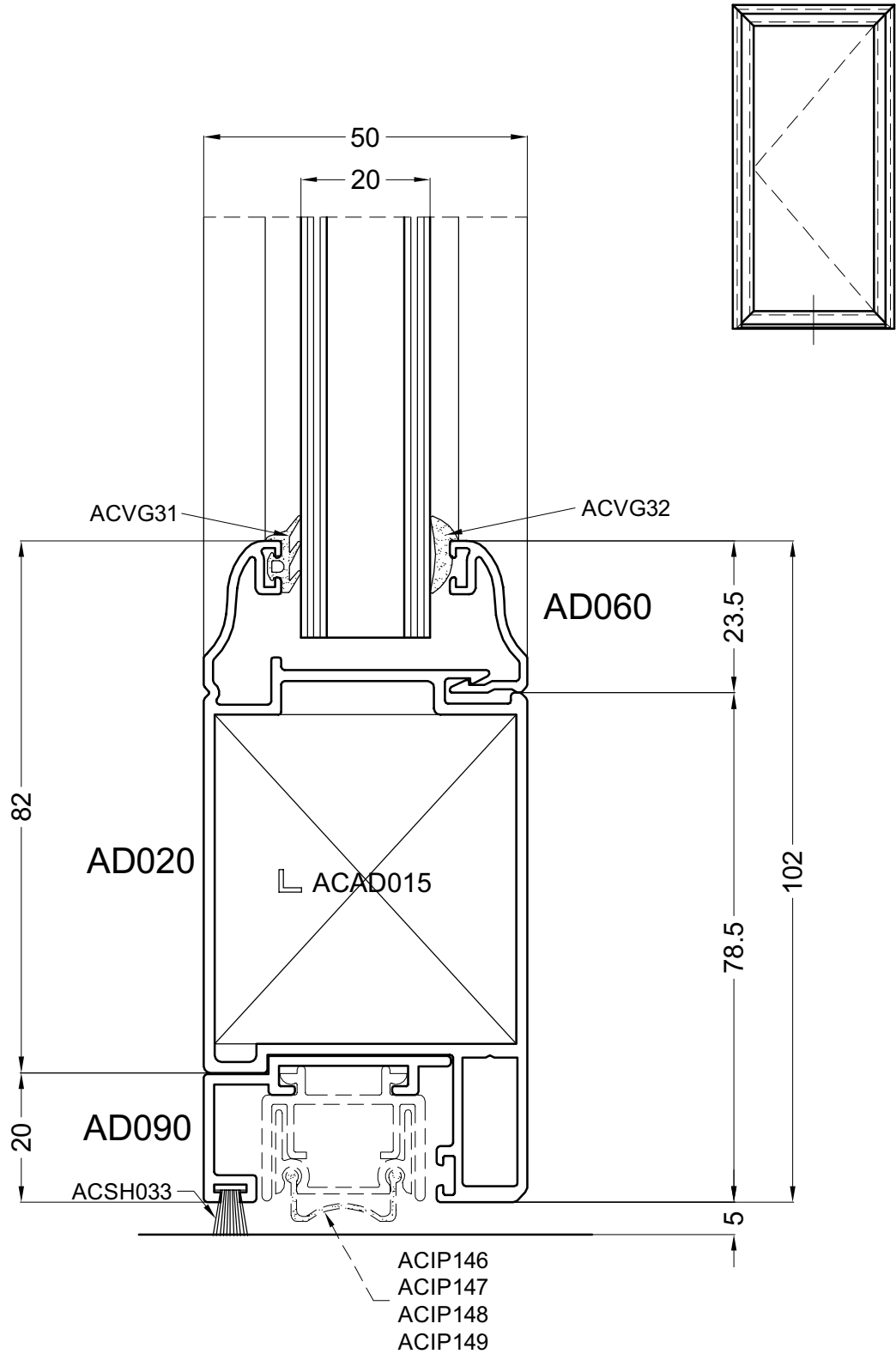

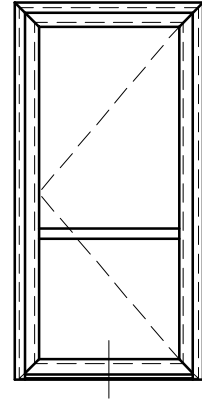
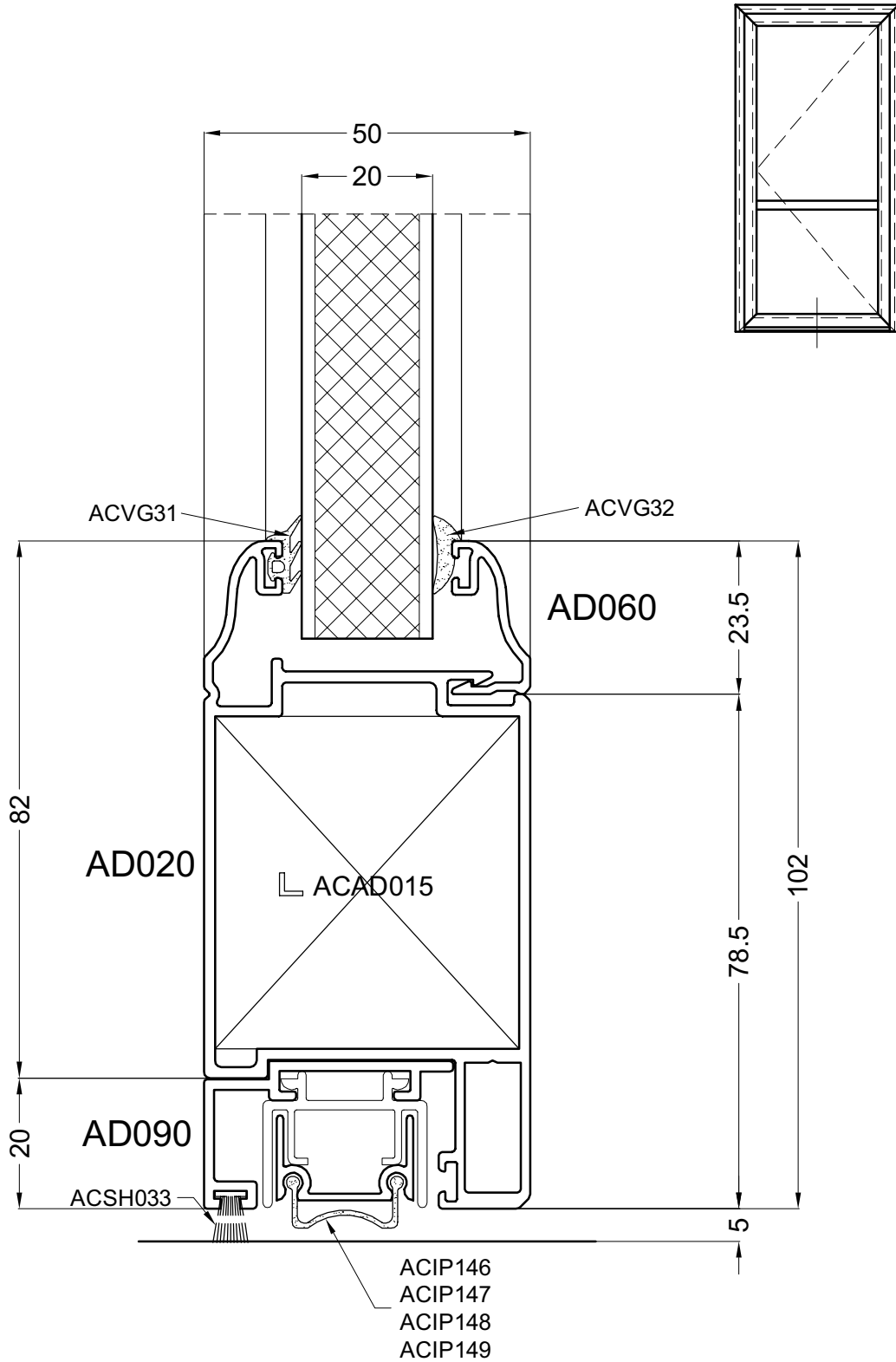

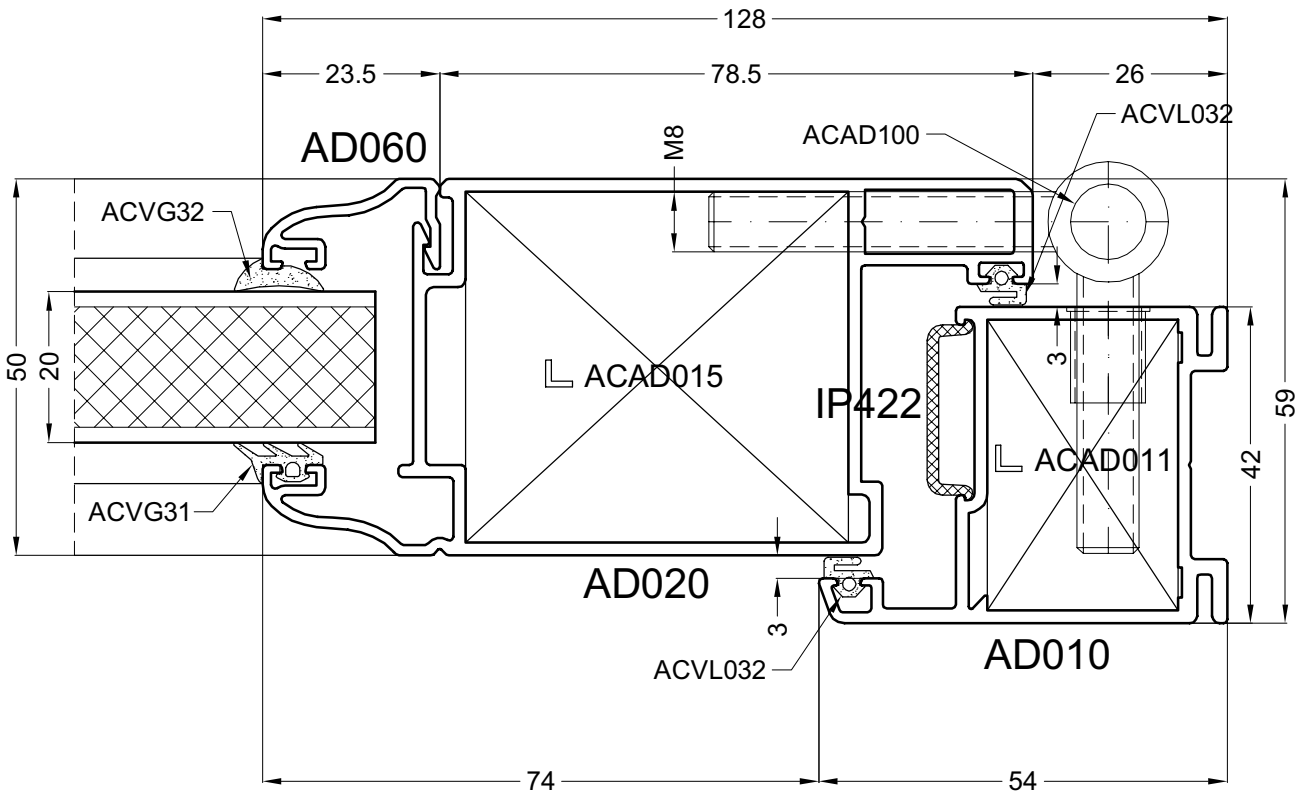
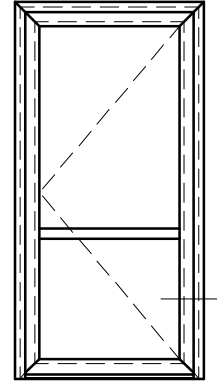

door6

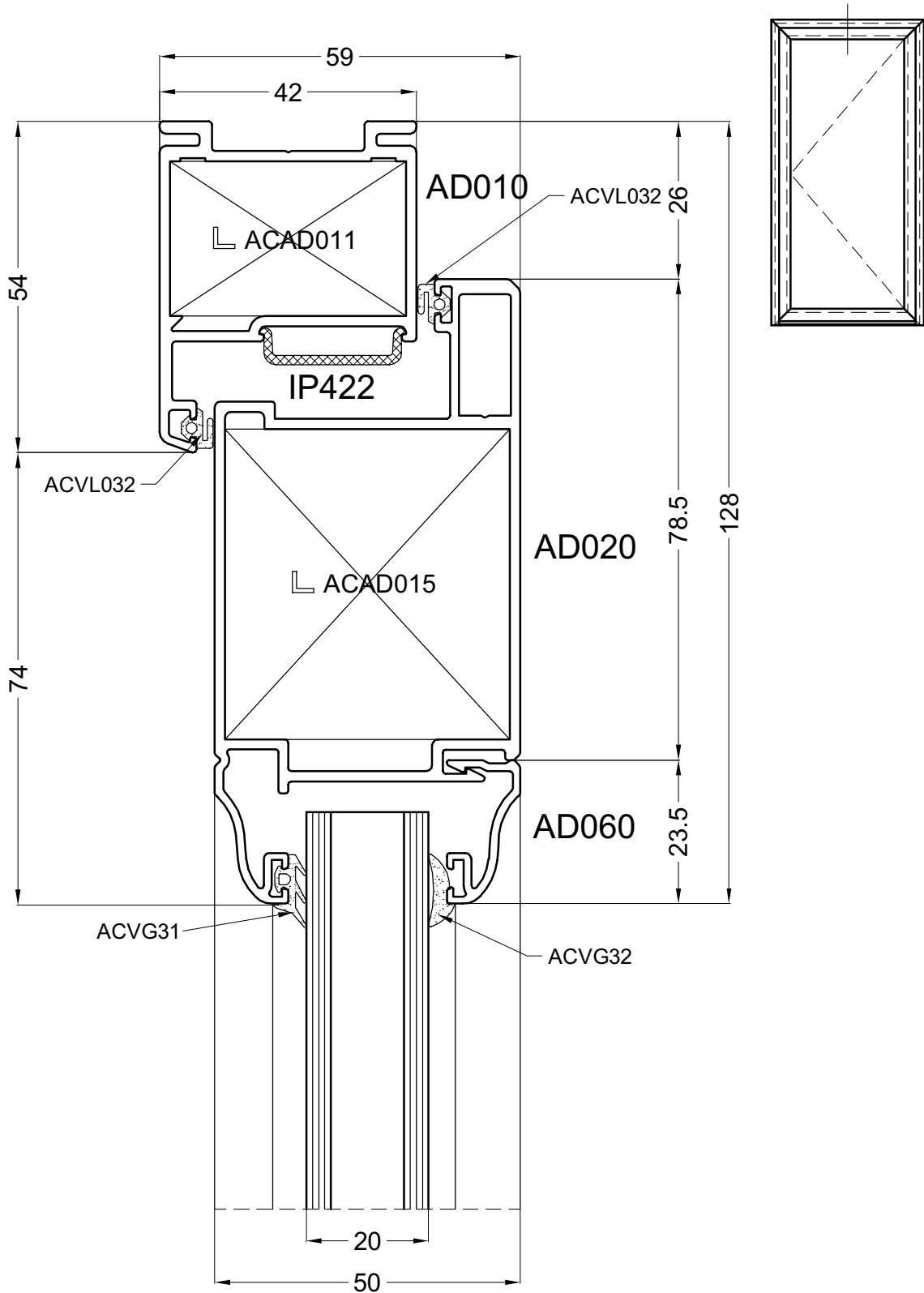

door7

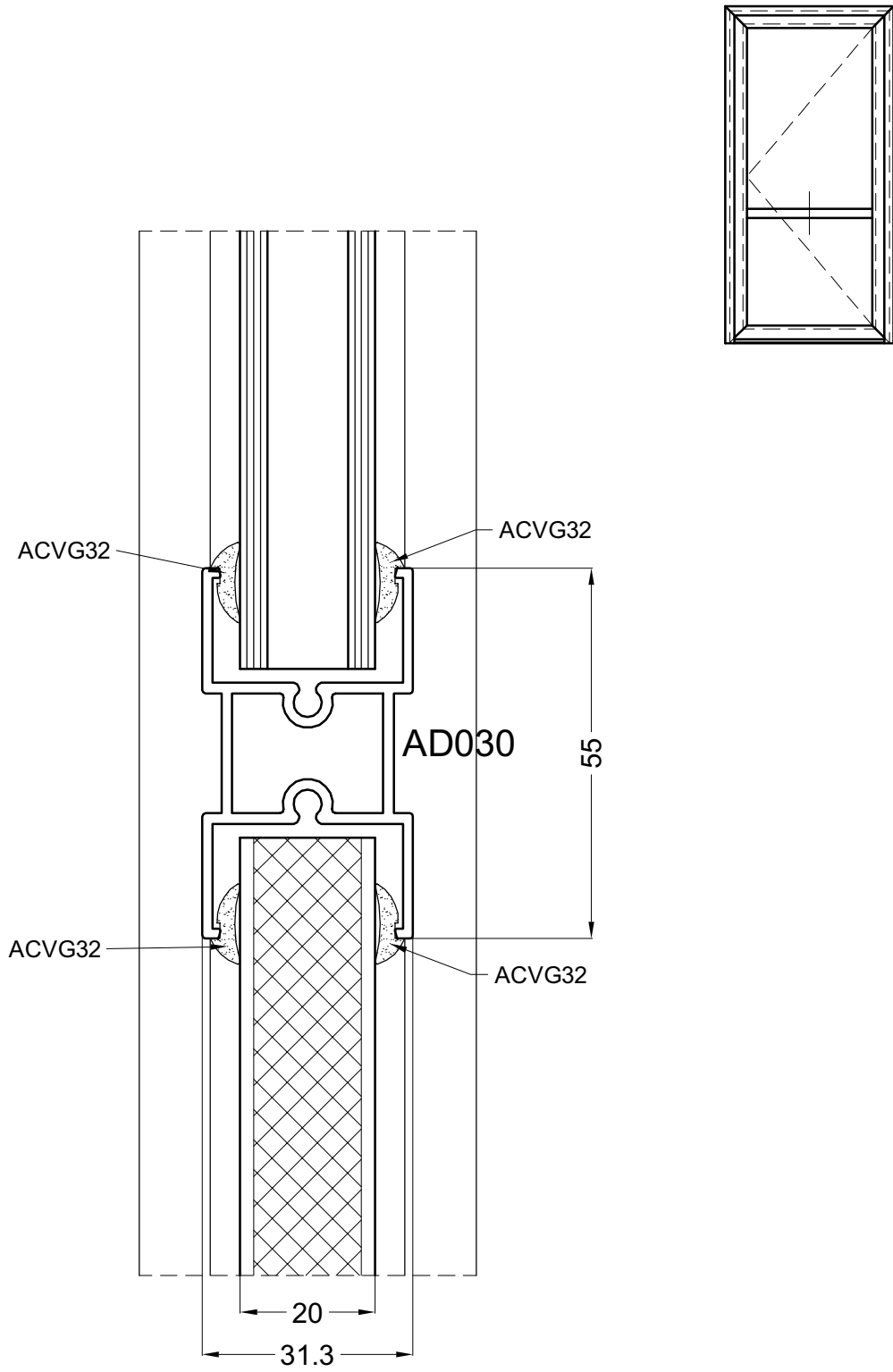

door8

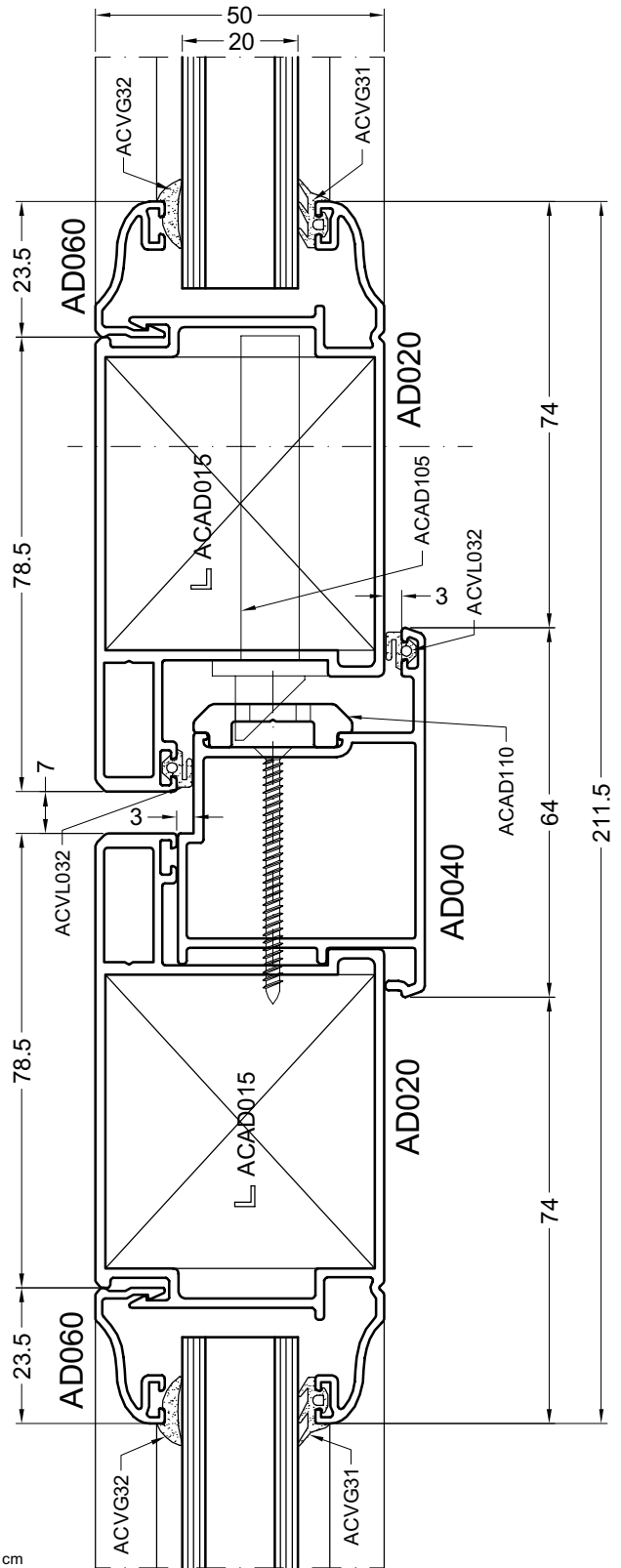
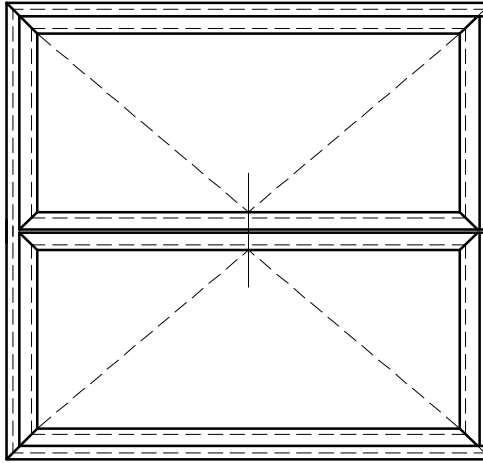

door9

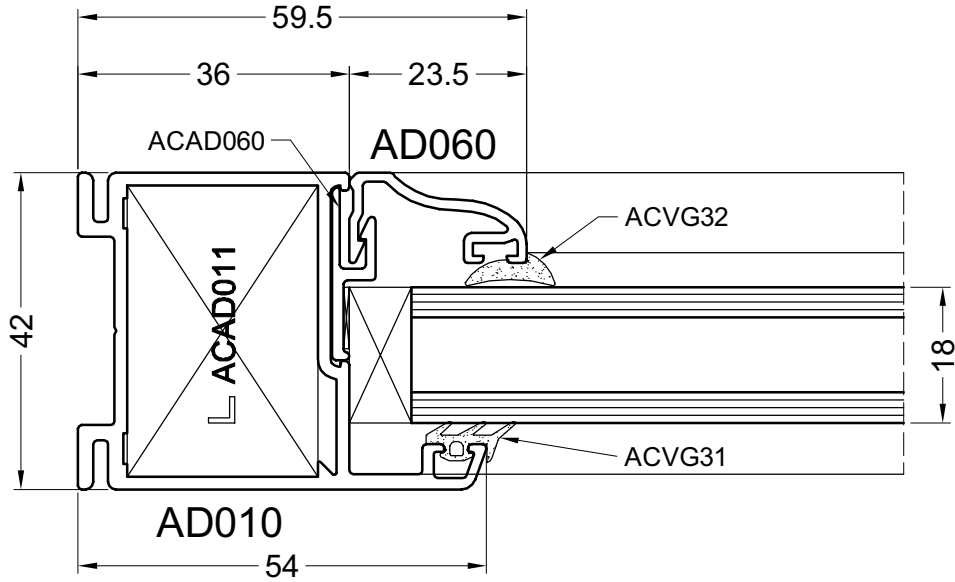
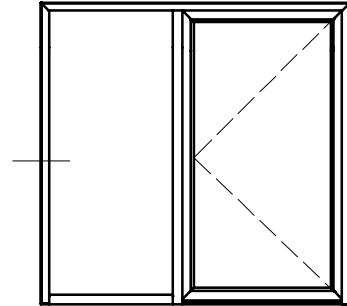

door10

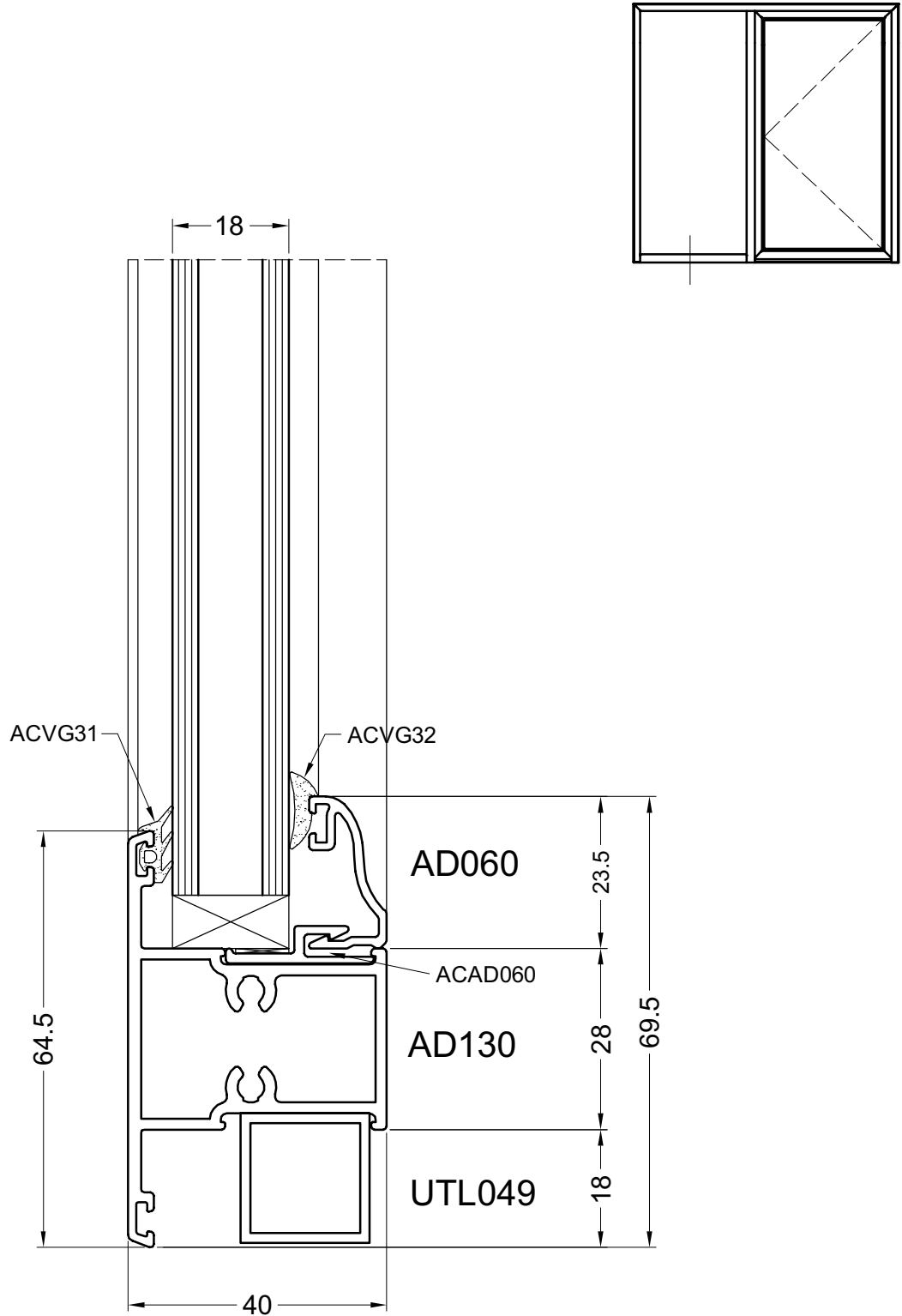

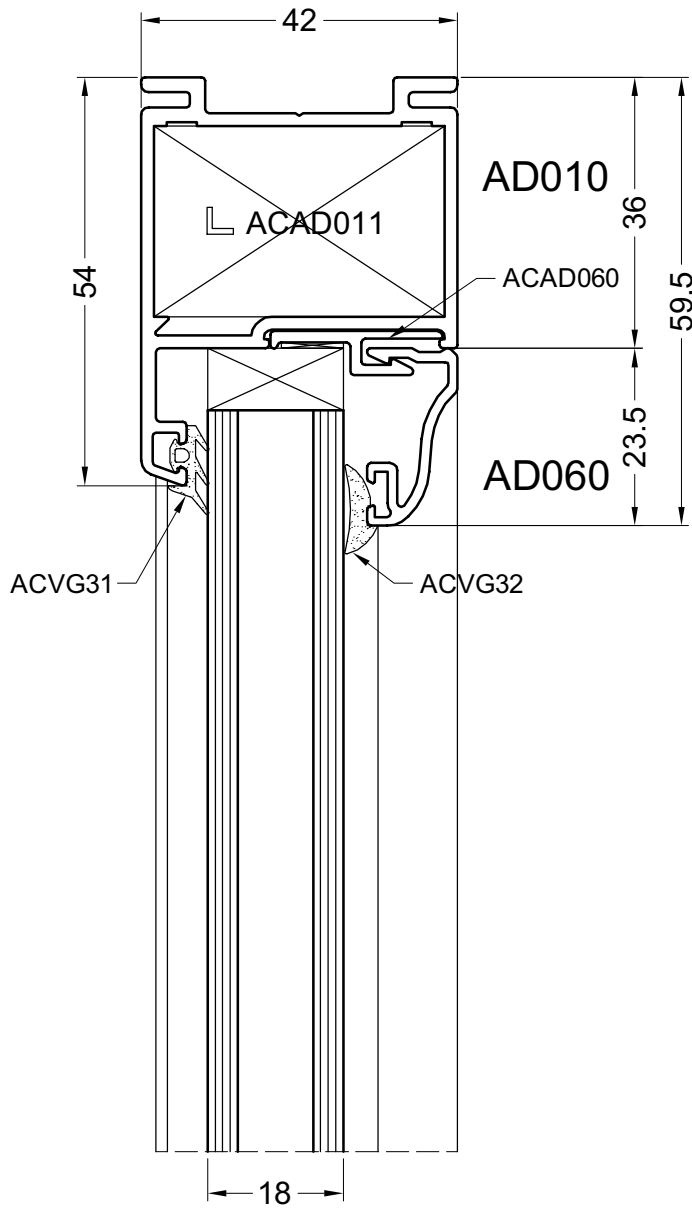
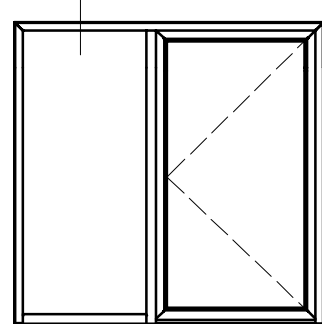

door12

13

DOORSNEDE - COUPE - SCHNITT - SECTION

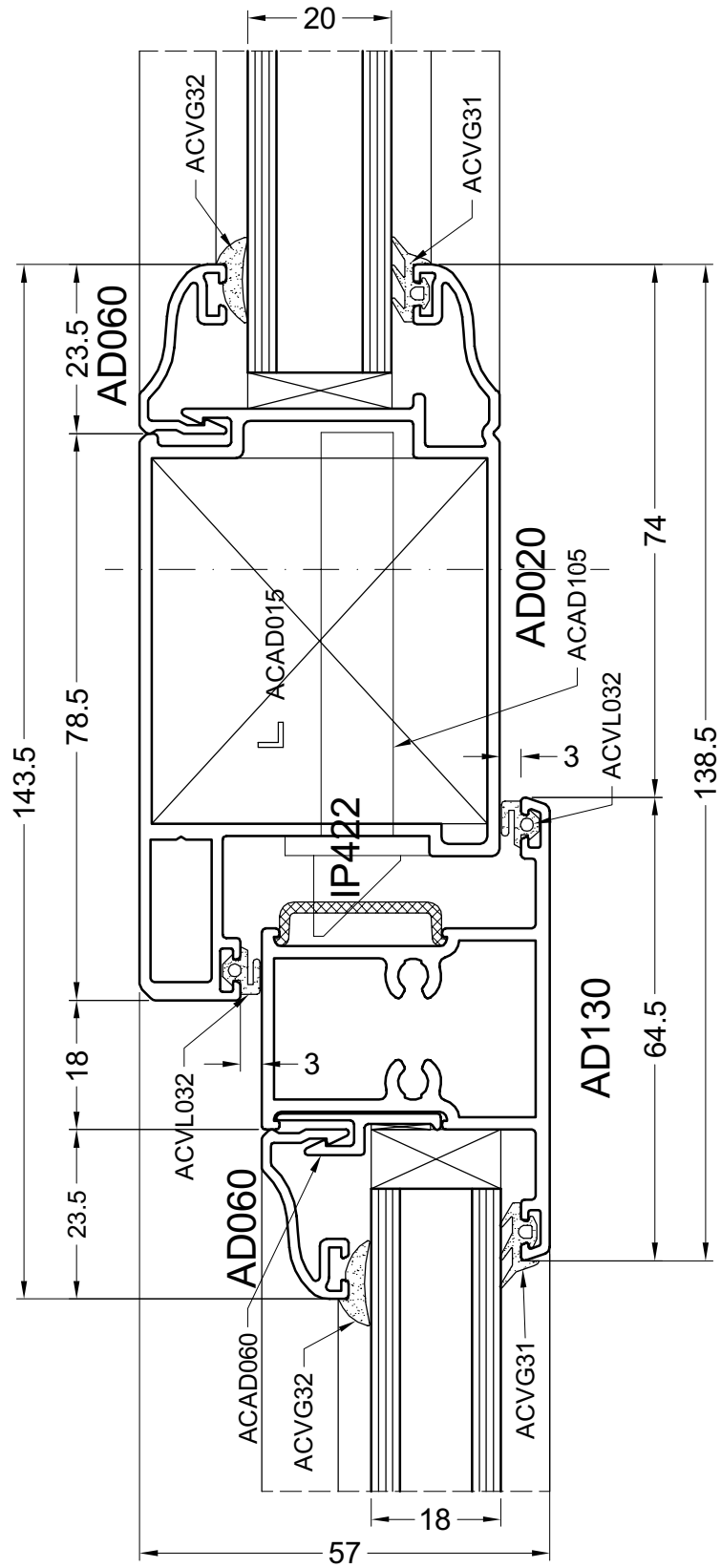
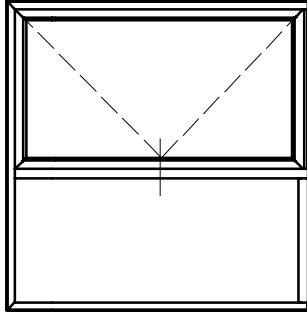

door13

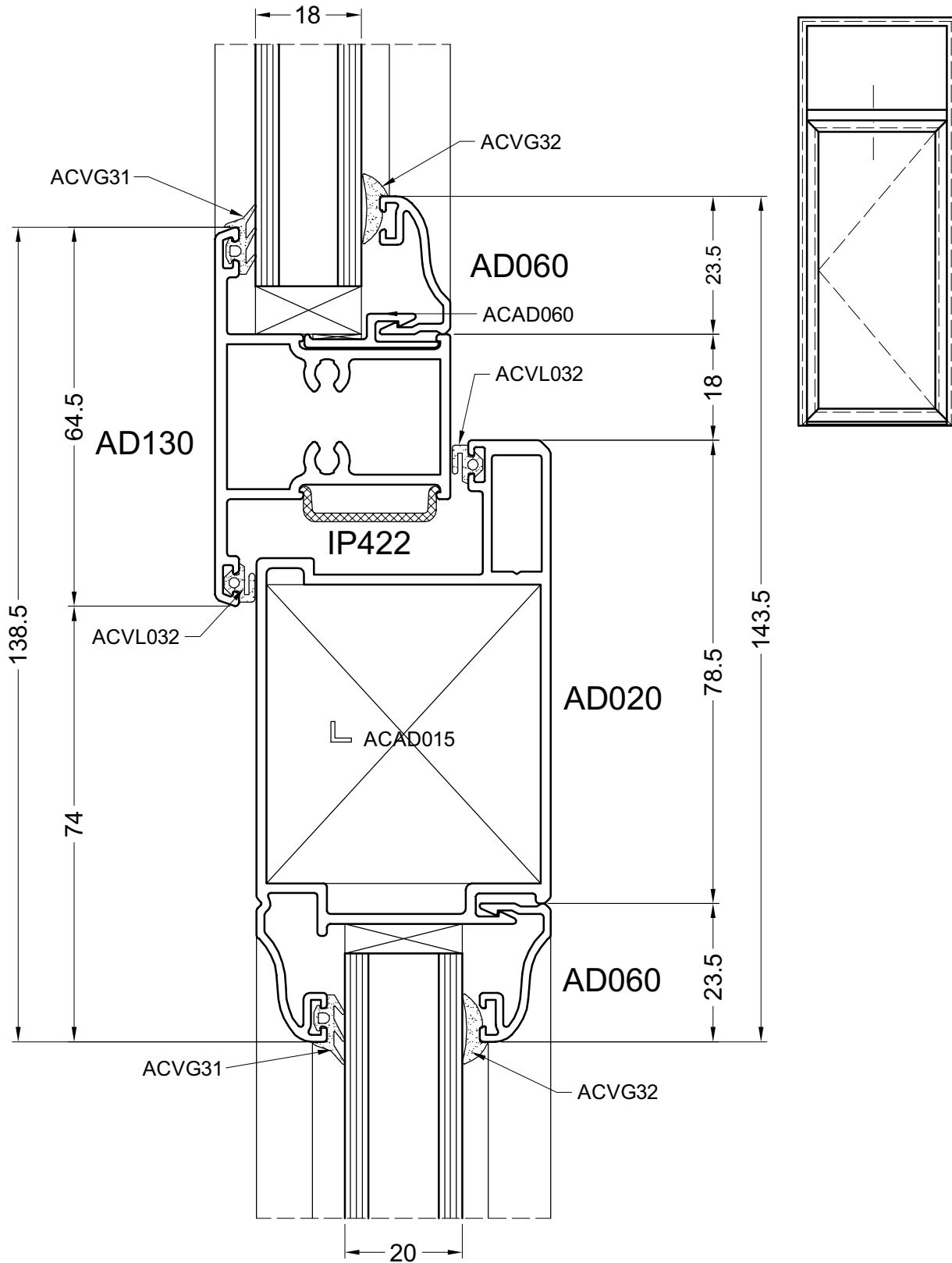

door14

BINNEDEUR
PORTE INTERIEURE
INNER TUR
INSIDE DOOR

ZAAGTABELLEN - TABLES DE SCIAGES - ZUSCHNITT-TABELLEN - SAWING TABLES

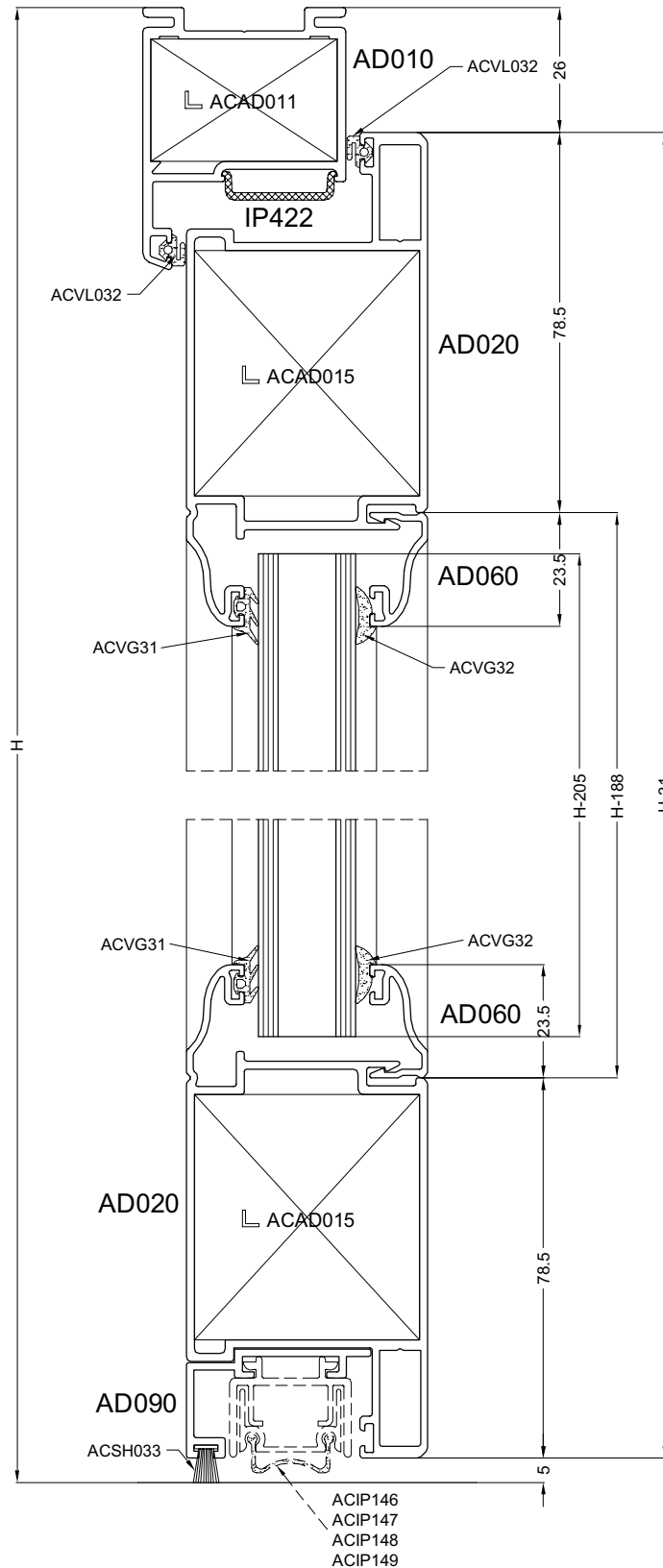

PROFIELEN PROFILES PROFILE PROFILS

AD010		1		B
AD010		1		H
AD010		1		H
AD020		2		B - 52
AD020		2		H - 31
AD060		2		B - 209
AD060		2		H - 188
AD090		1		B - 98
IP422		1		B - 67
IP422		2		H - 40

**TOEBEHOREN ACCESSOIRES
ZUBEHORTEILE ACCESSORIES**

ACAD011	2
ACAD015	4
ACAD043/044	2
ACAD100	2
ACAD101/102	2
ACAD105	1
ACAD110	1
ACVL032	2B + 4H - 300
ACVG31	2B + 2H - 850
ACVG3*	2B + 2H - 850
ACSH033	B - 98
ACIP146,147,148,149	B - 98

BORSTELDICHTING BRUSSE DESSOUS
BURSTENDICHTUNG BRUSH FITTING

ACSH033	1	B-98
---------	---	------

ACIP146/147/148/149	1	L = B - 98
ACIP146	Lmin=560mm	Lmax=710mm
ACIP147	Lmin=685mm	Lmax=835mm
ACIP148	Lmin=810mm	Lmax=960mm
ACIP149	Lmin=935mm	Lmax=1085mm

GLASMATEN
DIMENSIONS DES VITRAGES
GLASMASSE
GLASS SIZES

B - 226
H - 205

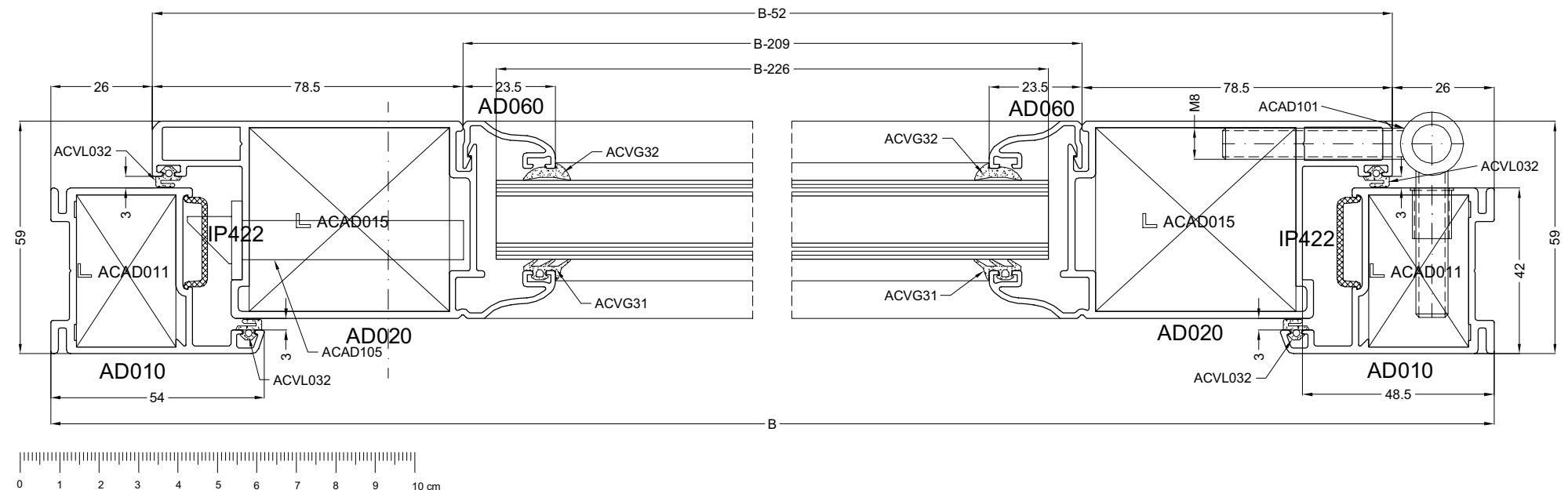
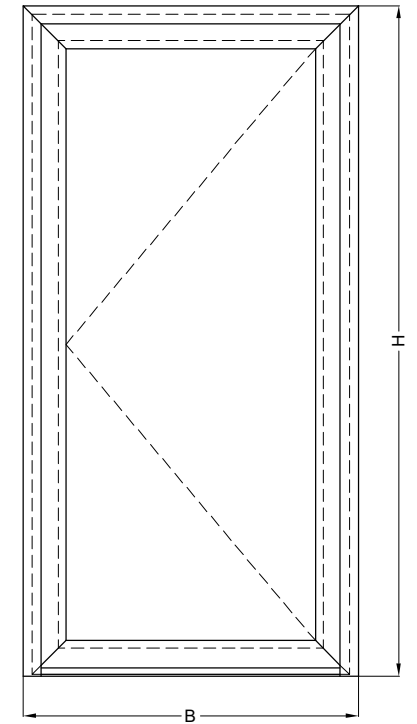

zaagad01

BINNENDEUR MET ZIJLICHT
PORTE INTERIEURE AVEC CONTRE-JOUR
INNER TUR MIT SEITENLICHT
INSIDE DOOR WITH SIDELIGHT

ZAAGTABELLEN - TABLES DE SCIAGES - ZUSCHNITT-TABELLEN - SAWING TABLES

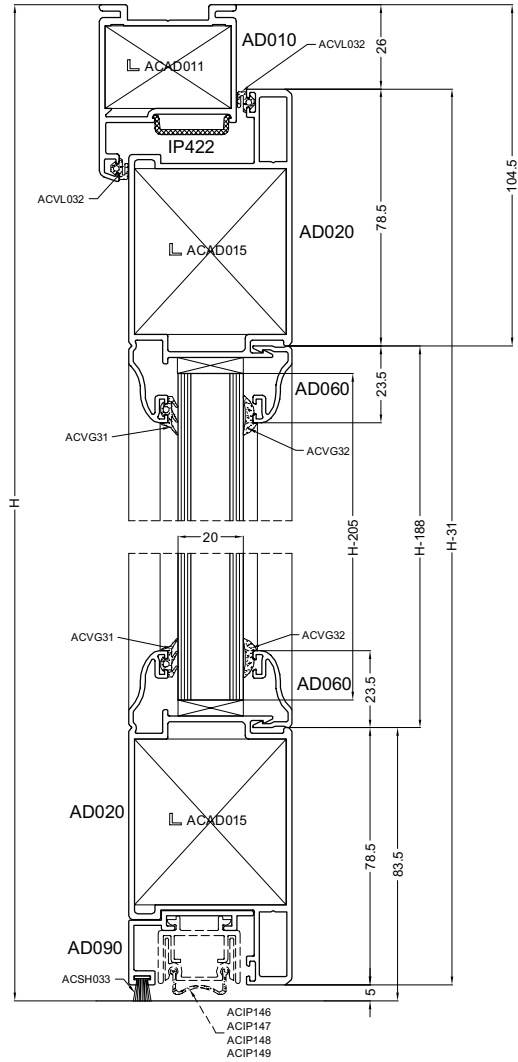
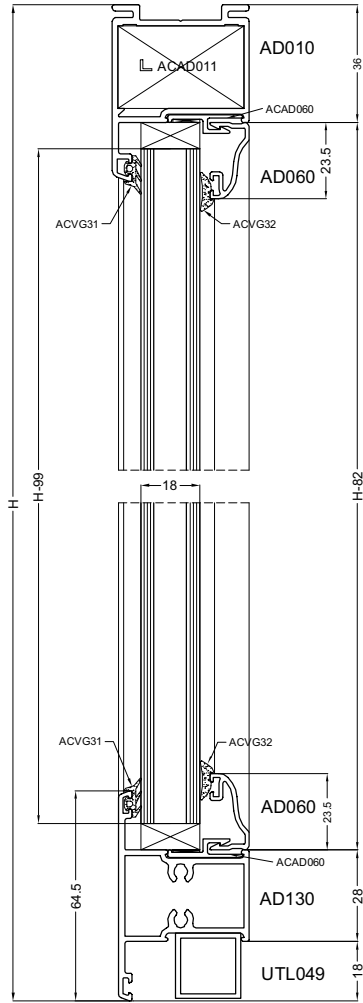

PROFIEN PROFILES PROFILE PROFILS

AD010	□	1	□	B
AD010	□	1	□	H
AD010	□	1	□	H
AD020	□	2	□	B1 - 30
AD020	□	2	□	H - 31
AD060	□	2	□	B1 - 204
AD060	□	2	□	H - 188
AD060	□	2	□	B2 - 50
AD060	□	2	□	H - 82
AD090	□	1	□	B - 75
AD130	□	1	□	H - 36
AD130	□	1	□	B2 - 50
IP422	□	1	□	B1 - 45
IP422	□	2	□	H - 40
UTL049	□	1	□	B2 - 50

TOEBEHOREN ACCESSOIRES
ZUBEHORTEILE ACCESSORIES

ACAD011	2
ACAD015	4
ACAD043/044	2
ACAD060	5st/m
ACAD100	2
ACAD101/102	2
ACAD105	1
ACAD110	1
ACVL032	2B1 + 4H - 200
ACVG31	2B1+2B2+4H-900
ACVG3*	2B1+2B2+4H-900
ACSH033	B1 - 70
ACIP146,147,148,149	B1 - 70
ACDR050	2

GLASMATEN DIMENSIONS DES VITRAGES 1= B1-204/H-205 (20mm)
GLASMASSE GLASS SIZES 2= B2-66/H-99 (18mm)

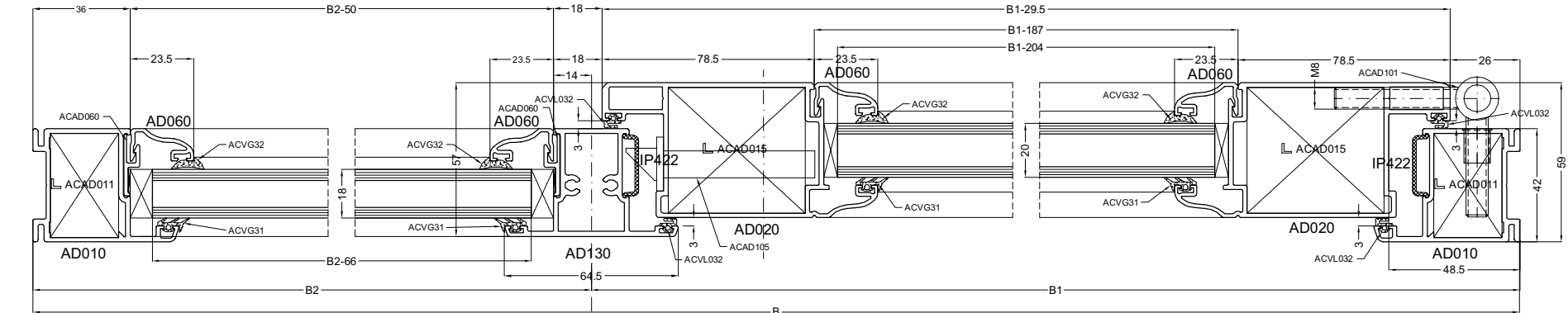
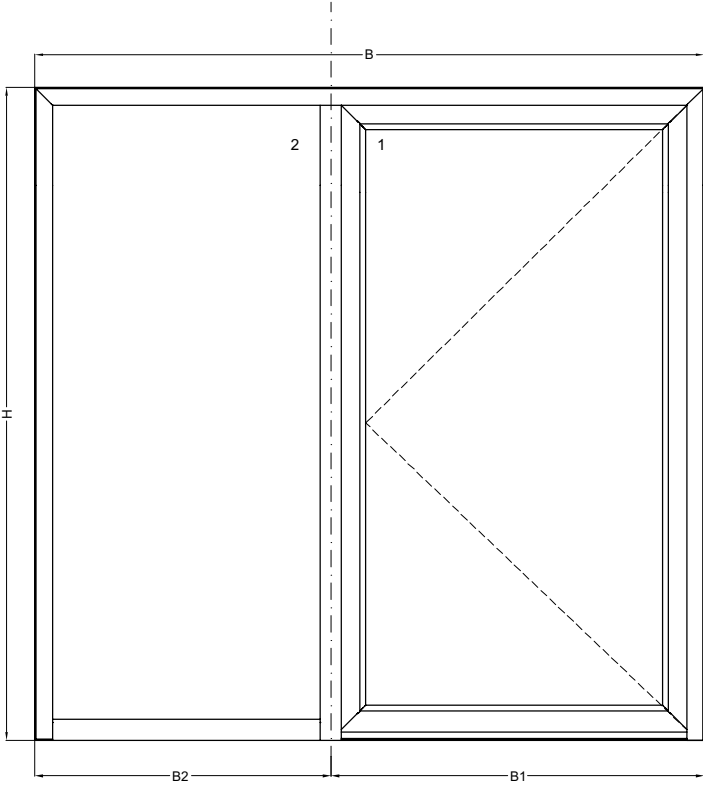

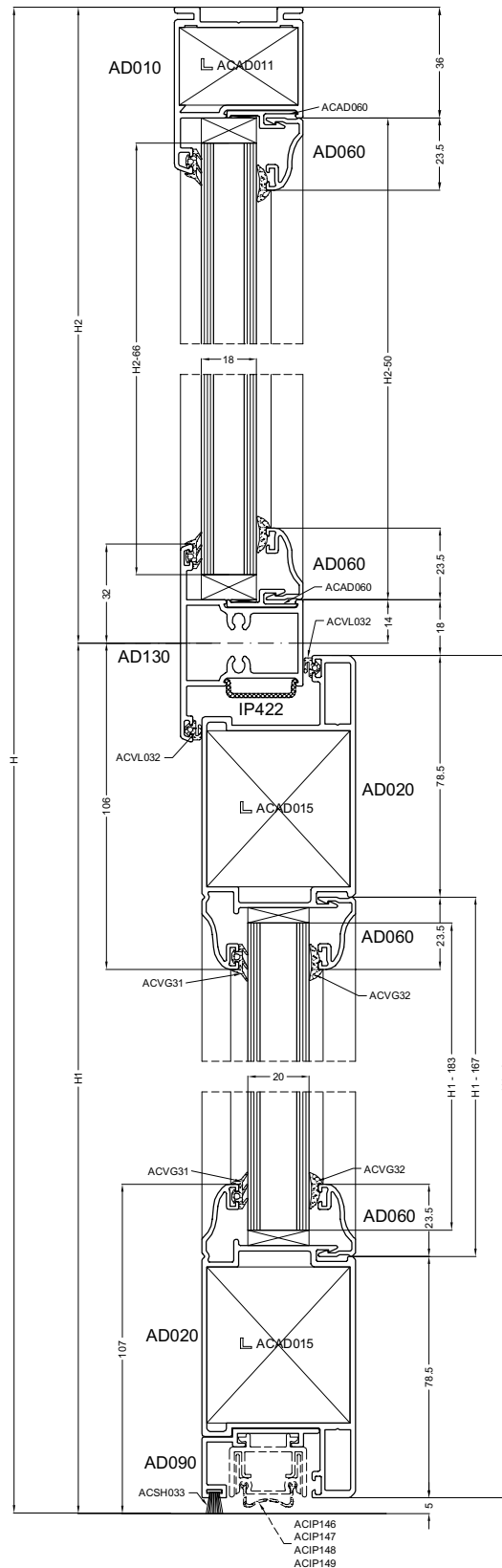

PROFIELEN PROFILES PROFILE PROFILS

AD010	□	1	▬	B
AD010	□	1	▬	H
AD010	□	1	▬	H
AD020	□	2	▬	B-52
AD020	□	2	▬	H1-9
AD060	▵	2	▬	B-72
AD060	▵	2	▬	H2-50
AD130	▬	1	▬	B - 72
AD060	▵	2	▬	B - 209
AD060	▵	2	▬	H1 - 166
AD090	▬	1	▬	B - 98
IP422	▵	1	▬	B - 67
IP422	▵	2	▬	H - 12

TOEBEHOREN ACCESSOIRES
ZUBEHÖRTEILE ACCESSORIES

ACAD011	2
ACAD015	4
ACAD043/044	2
ACAD060	5st/m
ACAD100	2
ACAD101/102	2
ACAD105	1
ACAD110	1
ACVL032	2B + 4H1 - 250
ACVG31	2H+2H2+4B-1100
ACVG3*	2H+2H2+4B-1100
ACSH033	B - 98
ACIP146,147,148,149	B - 98

GLASMATEN DIMENSIONS DES VITRAGES
GLASMASSE GLASS SIZES
1= H1-183/B-226 (20mm)
2= H2-66/B-88 (18mm)

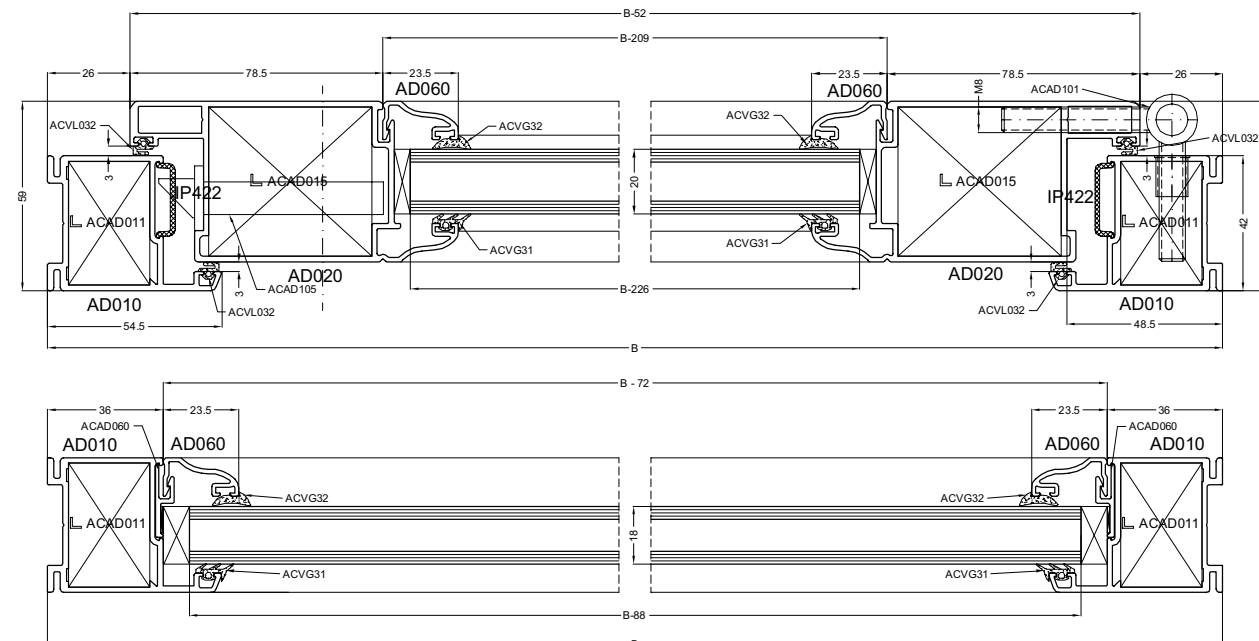
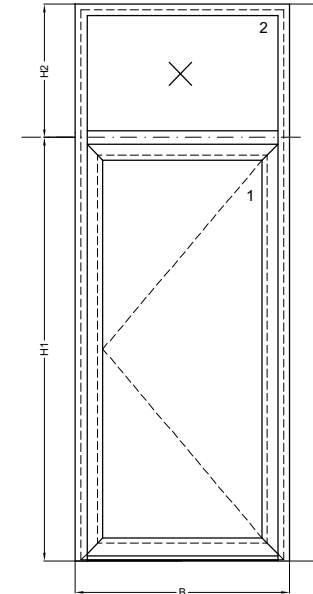

zaagad05

MONTAGE SCHROEFHOEK VOOR AD020
MONTAGE CLAME A VISSER POUR AD020
MONTAGE ECKVERBINDER SCHRAUBBAR FUR AD020
MONTAGE SQUARE COUPLING JOINT FOR AD020

WERKTEKENINGEN - DESSINS DE CONSTRUCTION - KONSTRUKTIONZEICHNUNGEN - CONSTRUCTION DRAWINGS

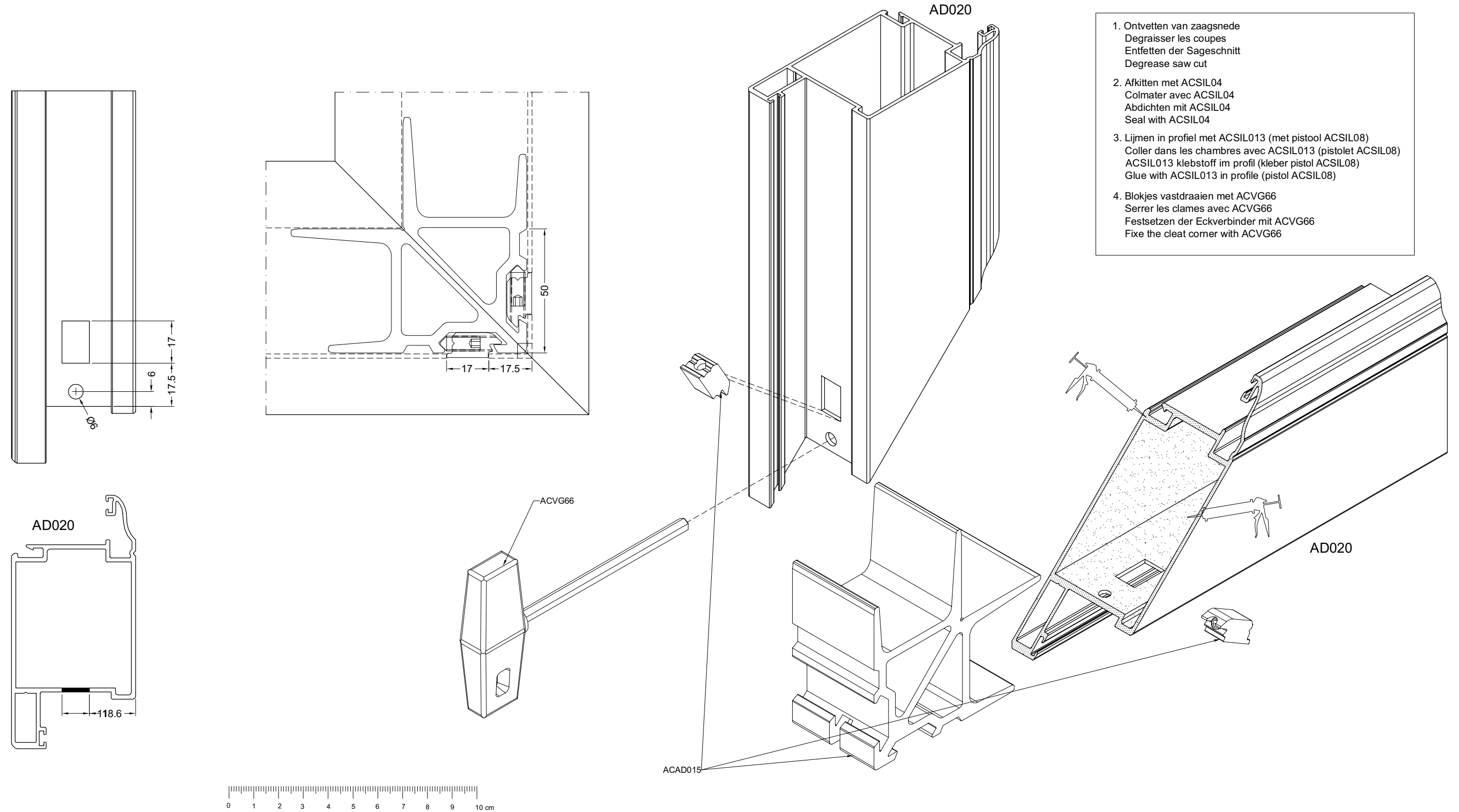

MONTAGE AD020/AD030
MONTAGE AD020/AD030
MONTAGE AD020/AD030
MONTAGE AD020/AD030

WERKTEKENINGEN - DESSINS DE CONSTRUCTION - KONSTRUKTIONZEICHNUNGEN - CONSTRUCTION DRAWINGS

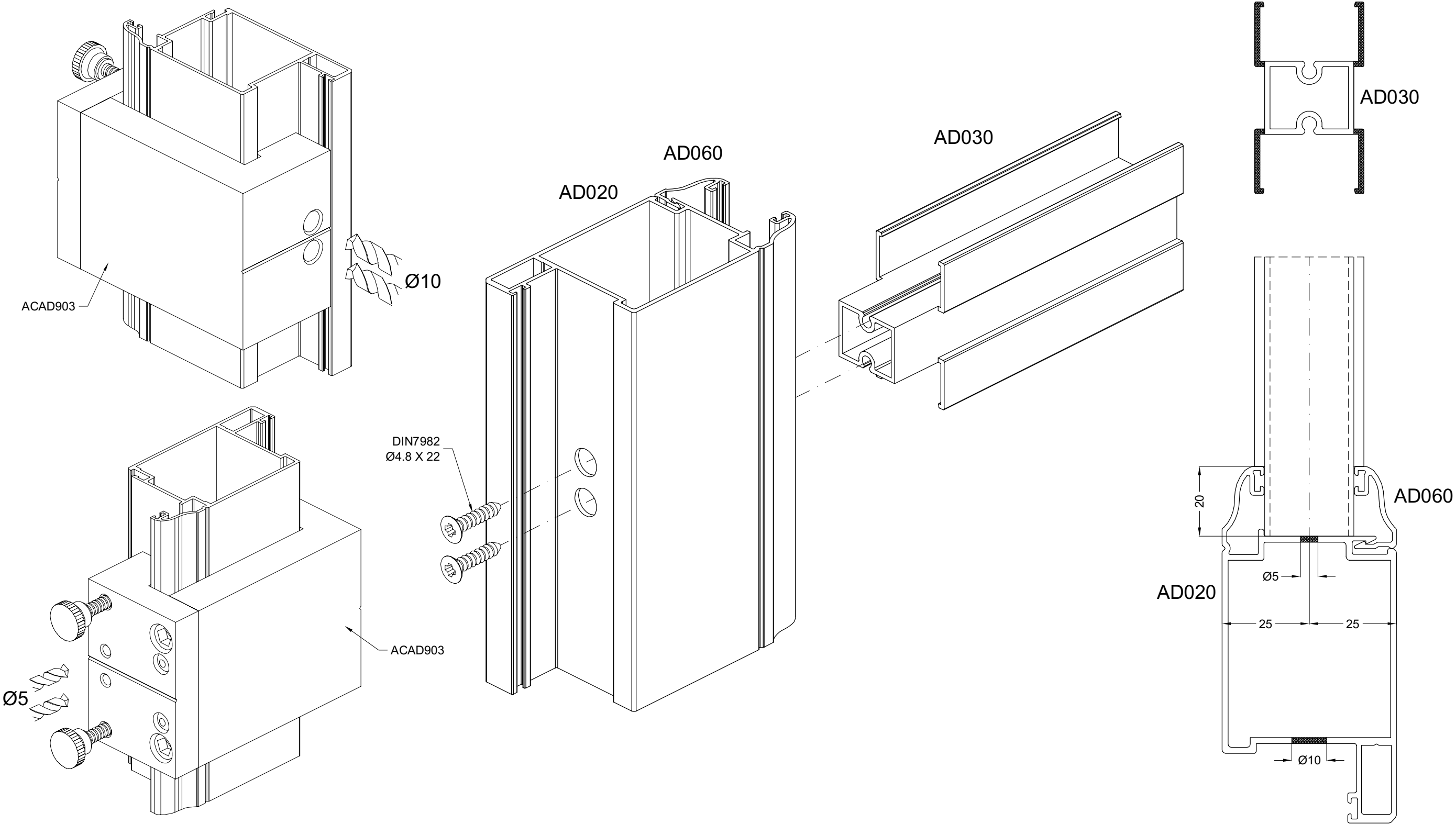

tverb

UITSPARING VOOR SLOT
ENTAILLE POUR SERRURE
EINBAU FÜR SCHLOSSER
EMBEDDING FOR LOCK

WERKTEKENINGEN - DESSINS DE CONSTRUCTION - KONSTRUKTIONZEICHNUNGEN - CONSTRUCTION DRAWINGS

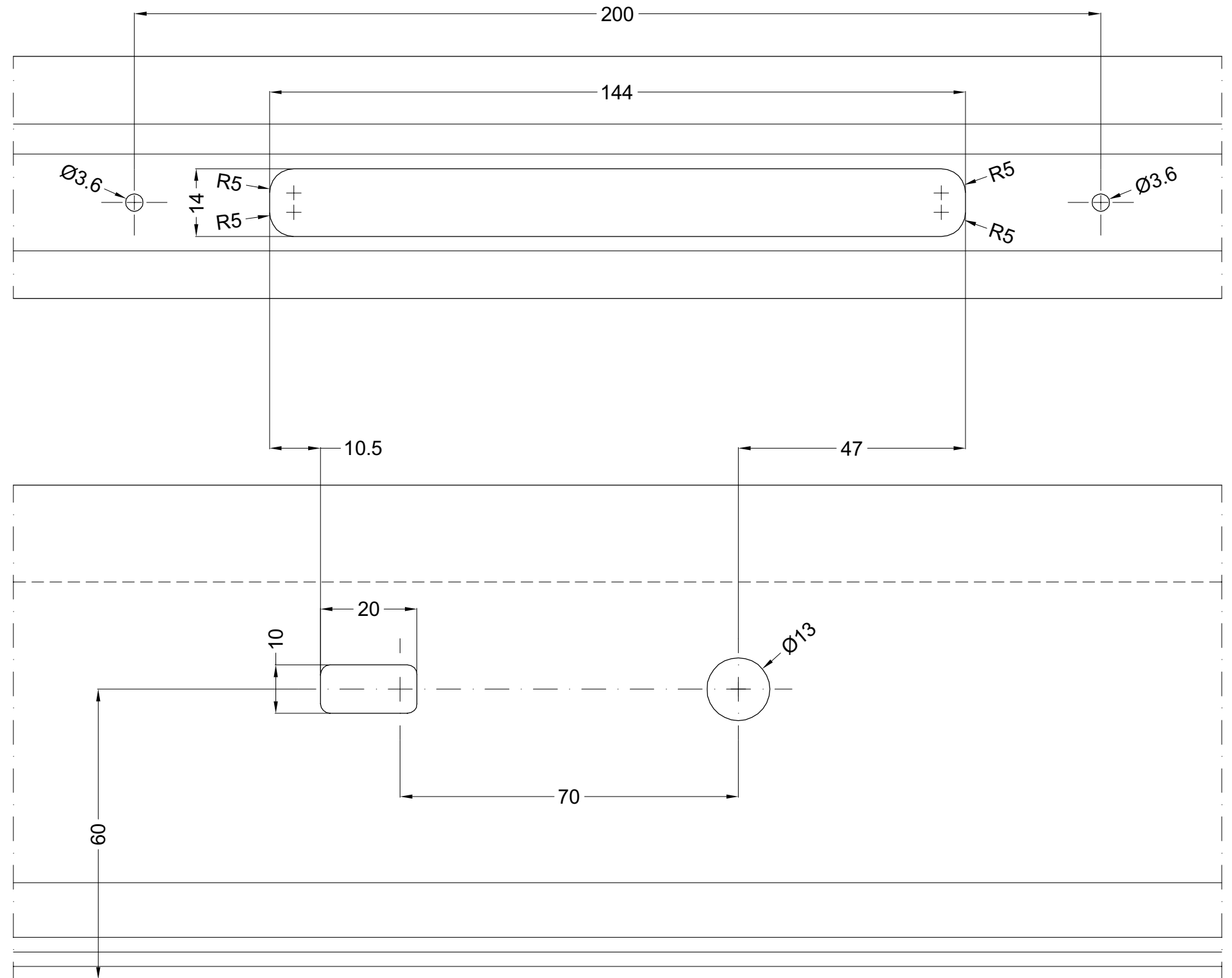
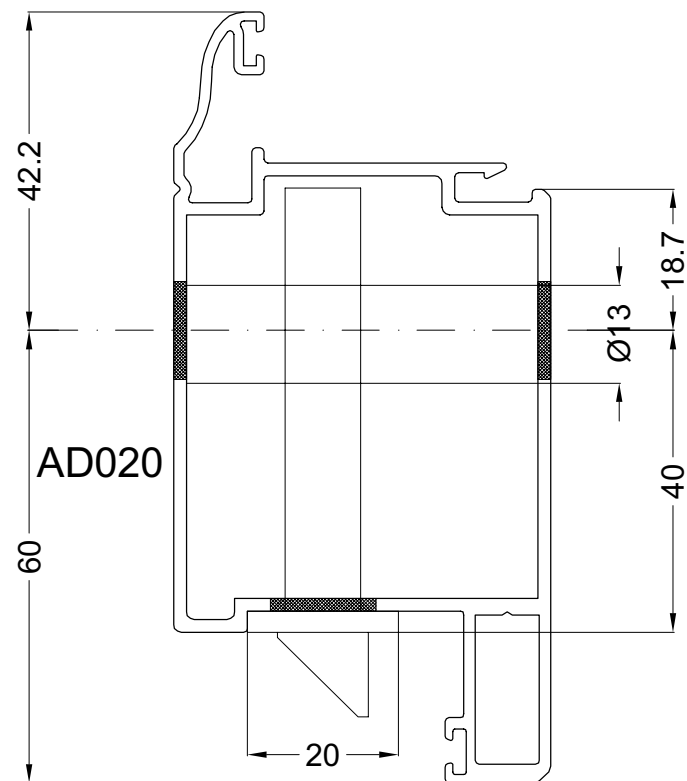
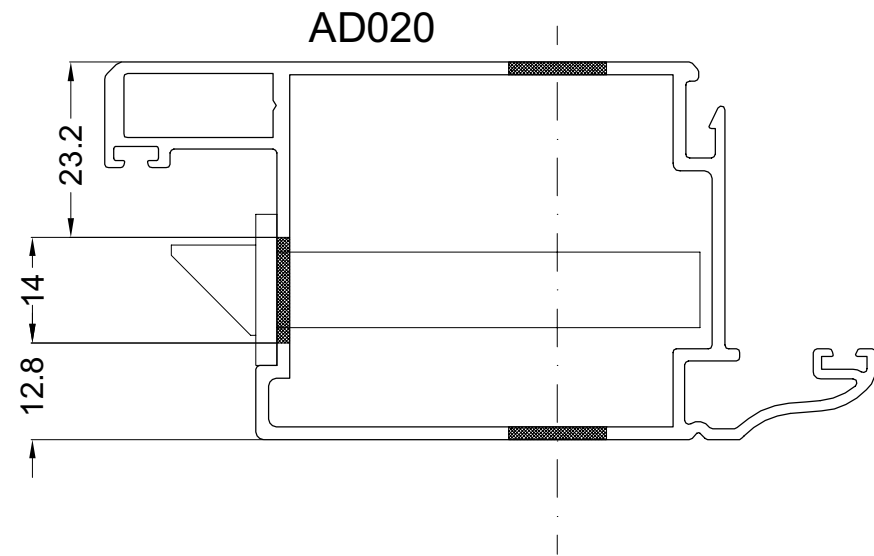

uitslot

MONTAGE ACAD100 + ACAD101
MONTAGE ACAD100 + ACAD101
MONTAGE ACAD100 + ACAD101
MONTAGE ACAD100 + ACAD101

WERKTEKENINGEN - DESSINS DE CONSTRUCTION - KONSTRUKTIONZEICHNUNGEN - CONSTRUCTION DRAWINGS

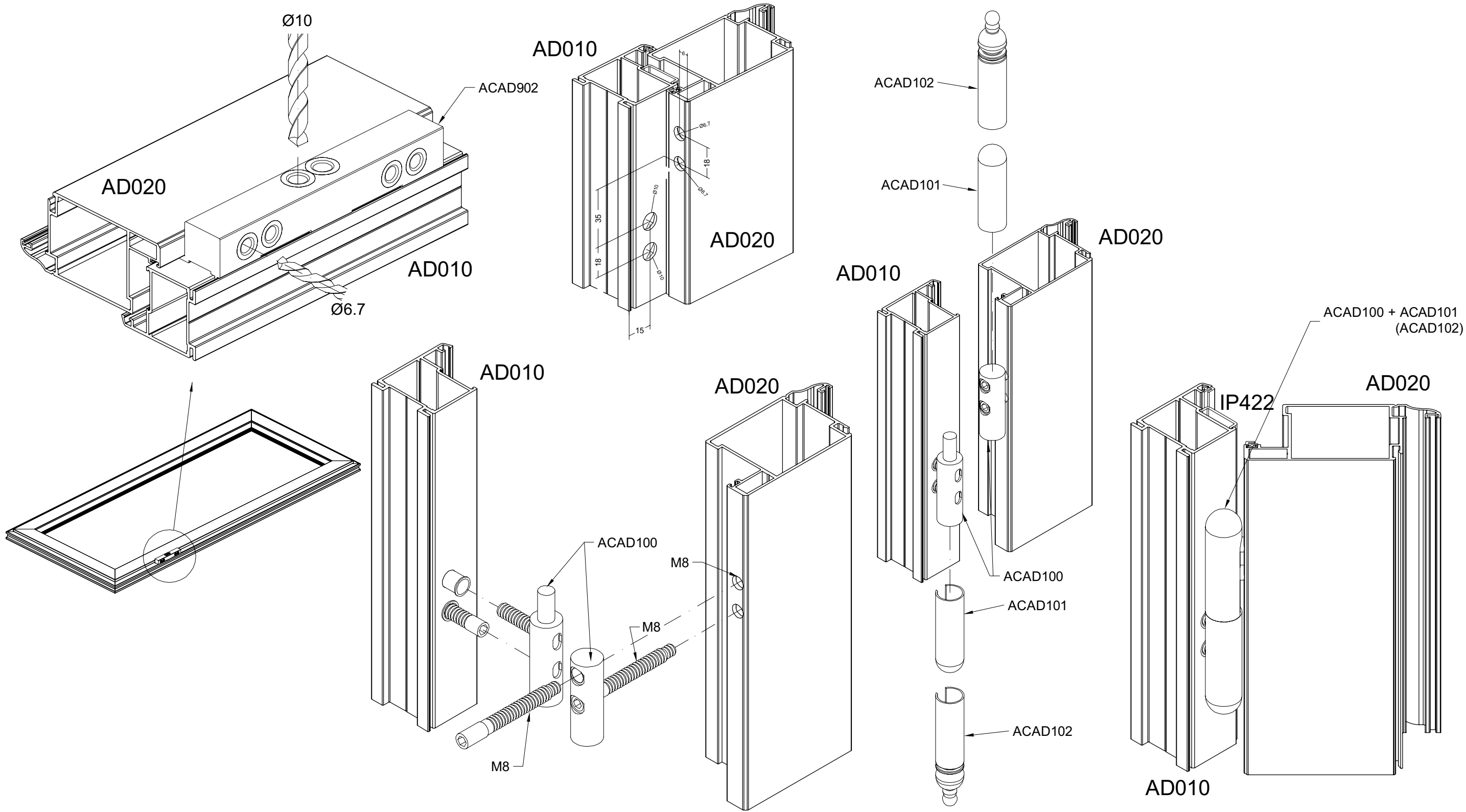

MONTAGE AD040
MONTAGE AD040
MONTAGE AD040
MONTAGE AD040

WERKTEKENINGEN - DESSINS DE CONSTRUCTION - KONSTRUKTIONZEICHNUNGEN - CONSTRUCTION DRAWINGS

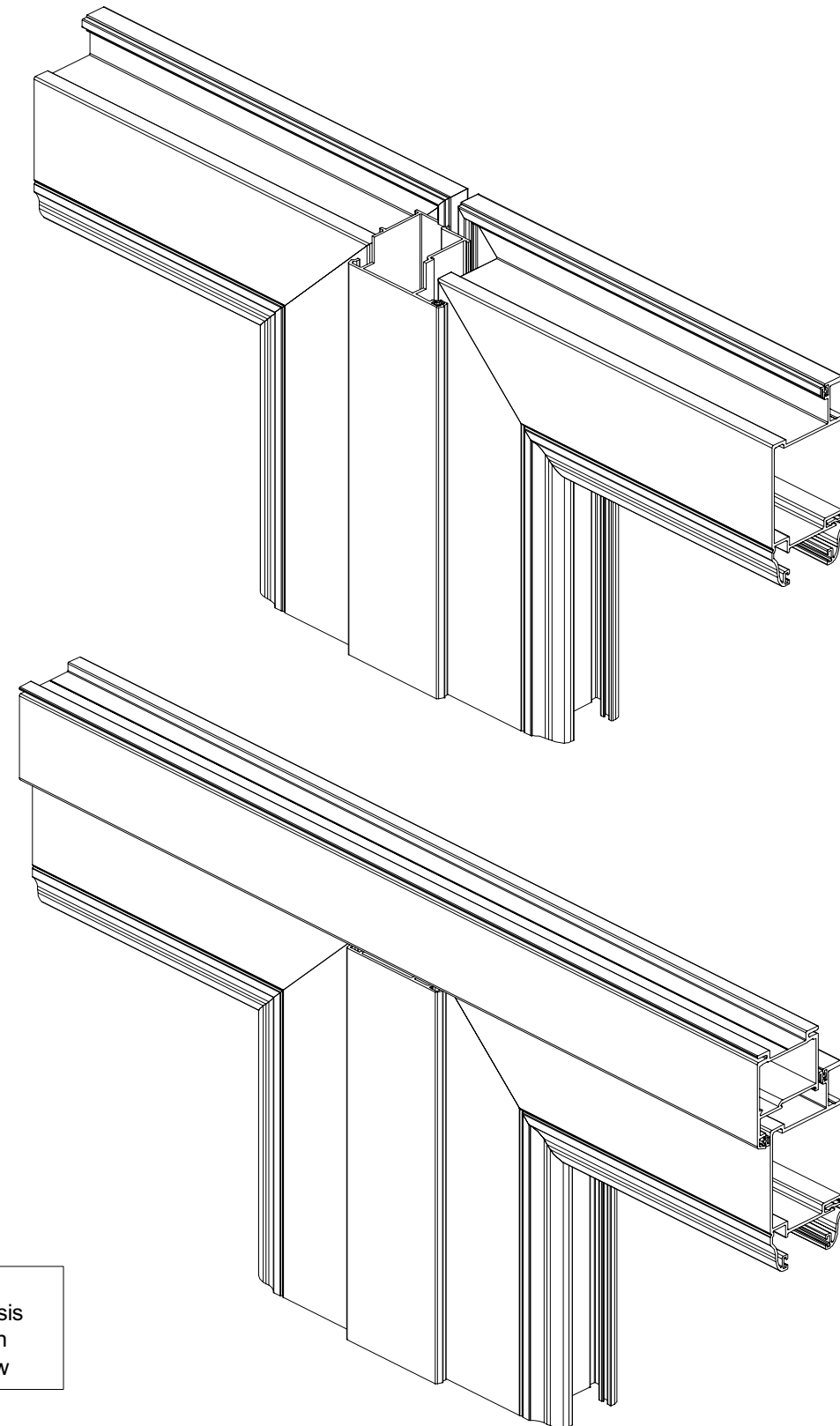
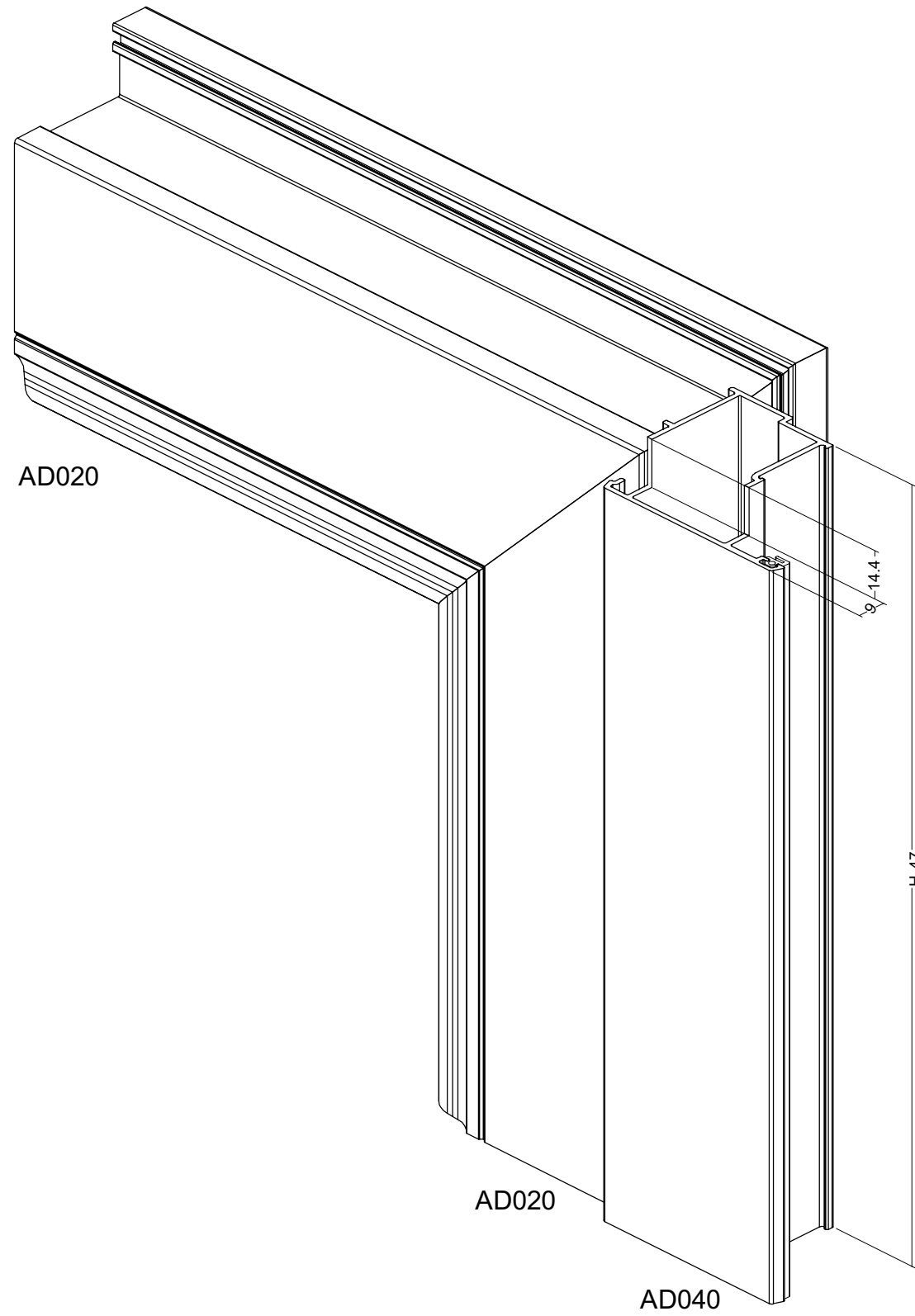

H = Hoogte raam
Hauteur chassis
Hohe Rahmen
Height window

MONTAGE AD130
MONTAGE AD130
MONTAGE AD130
MONTAGE AD130

WERKTEKENINGEN - DESSINS DE CONSTRUCTION - KONSTRUKTIONZEICHNUNGEN - CONSTRUCTION DRAWINGS

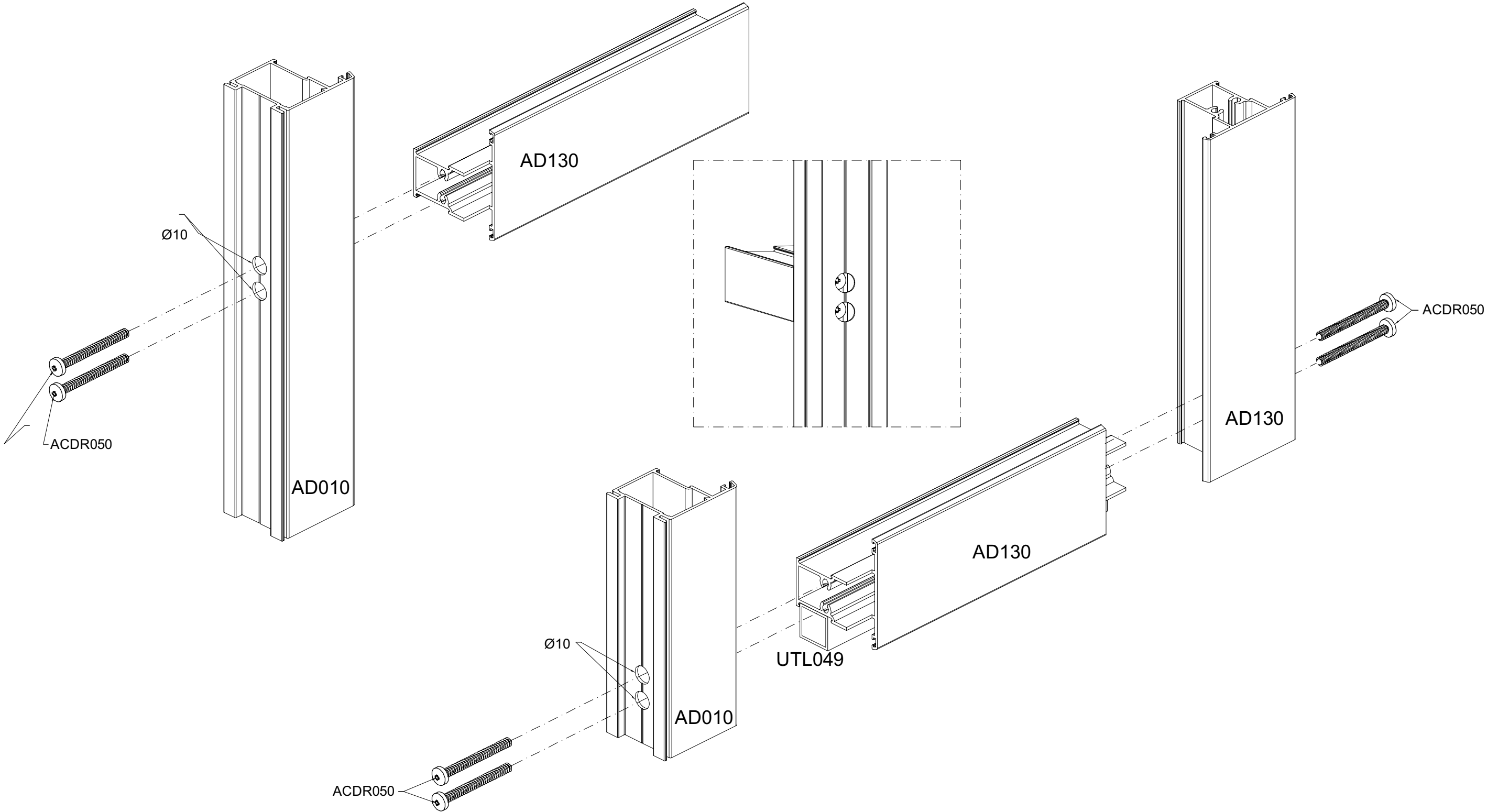

montage