

slide cold

5/2/2008

SCHUIFRAMEN EN -DEUREN
FENETRES ET PORTES COULISSANTES
SCHIEBEFENSTER UND SCHIEBETUREN
SLIDING WINDOWS AND SLIDING DOORS

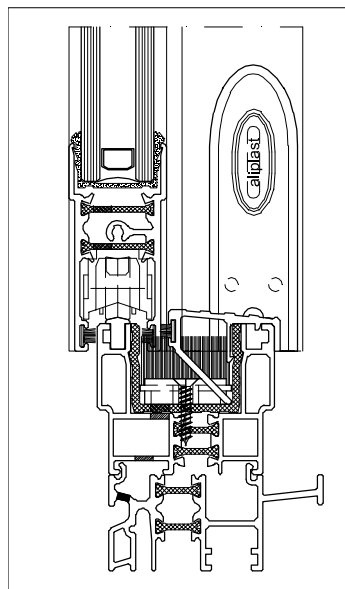

SLa

PROFIELEN _____ P. 13

PROFILS
PROFILE
PROFILES

SLb

TOEBEHOREN _____ P. 23

ACCESSOIRES
ZUBEHORTEILE
ACCESSORIES

SLc

DOORSNEDEN _____ P. 39

COUPES
SCHNITT
SECTIONS

SLd

STATICA _____ P. 69

STATIQUE
STATIK
STATICS

SLe

ZAAGTABELLEN _____ P. 79

TABLES DE SCIAGES
ZUSCHNITT-TABELLEN
SAWING TABLES

SLf

WERKTEKENINGEN _____ P. 89

DESSINS DE CONSTRUCTION
KONSTRUKTIONZEICHNUNGEN
CONSTRUCTION DRAWINGS

AFKORTINGEN / ABBREVIATIONS / ABKURZUNGEN / ABBREVIATIONS

BR = BRUT - BRUT - ROH - BRUT

AN = GEANODISEERD - ANODISE - ELOXIERT - ANODISED

AN (■) = GELAKT - LAQUE - LACKIERT - LACQUERED -- RAL9006M

KL = STANDAARDKLEUREN - COULEURS STANDARDS - BASIS FARBEN - BASIC COLORS

GS = SPECIAAL GEMOFFELD - LAQUE SPECIAL - SPECIALFARBE - SPECIAL COLOR

Z = ZWART - NOIR - SCHWARZ - BLACK

W = WIT - BLANC - WEISS - WHITE

De tekeningen die voorgesteld zijn op schaal 1:1, kunnen kleine maatafwijkingen vertonen, te wijten aan de reproductietechniek van deze catalogoog.

Les dessins représentés à l'échelle 1 peuvent avoir de légères variations dimensionnelles dues aux techniques de reproduction de ce catalogue.

Die Zeichnungen im Maßstab 1:1 können aus technischen Reproduktionsgründen leichte Messungsschwankungen darstellen.

The drawings represented on a scale 1 basis may have light dimensional variations due to the reproduction of the manual.

BUITENKADERS	P. 13
PROFILS D'ENCADREMENT KADERPROFILE OUTER FRAMES	
VLEUGELREGELS	P. 15
TRAVERSE FLUGELPRIEGEL VENT TRANSOMS	
VLEUGELSTIJLEN	P. 16
MONTANTS GLUGELPFOSTEN VENTPOST	
MIDDENSTIJLEN	P. 17
PROFILS CHICANES WECHSELPROFIL CHICANES	
TUSSENREGELS	P. 18
TRAVERSES SPROSSENPROFIELEN TRANSOMS	
DORPELS	P. 19
SEUILS SOLL-PROFIELEN SILL MEMBERS	
DIVERSE PROFIELEN	P. 20
PROFILS DIVERS DIVERS PROFIELEN VARIED PROFILES	

SCHUIFRAMEN _____ P. 39

FENETRES COULISSANTES
SCHIEBEFENSTER
SLIDING WINDOWS

SCHUIFDEUREN _____ P. 59

PORTES COULISSANTES
SCHIEBETUREN
SLIDING DOORS

GLASTABEL _____ P. 67

TABLE DE VITRAGE
BEGLAZUNG TABEL
GLAZING TABLE

- 1 VLEUGELIG SCHUIFRAAM _____ P. 79
FENETRE COULISSANTE 1 VANTAUX
SCHIEBEFENSTER 1 FLUGEL
SLIDING WINDOW WITH ONE PANEL
- 2 VLEUGELIG SCHUIFRAAM _____ P. 81
FENETRE COULISSANTE DEUX VANTAUX
SCHIEBEFENSTER 2 FLUGEL
DOUBLE SLIDING WINDOW
- 3 VLEUGELIG SCHUIFRAAM _____ P. 85
FENETRE COULISSANTE TROIS VANTAUX
SCHIEBEFENSTER 2 FLUGEL
DOUBLE SLIDING WINDOW
- 4 VLEUGELIG SCHUIFRAAM _____ P. 86
FENETRE COULISSANTE QUATRE VANTAUX
SCHIEBEFENSTER 2 FLUGEL
DOUBLE SLIDING WINDOW
- 6 VLEUGELIG SCHUIFRAAM _____ P. 87
FENETRE COULISSANTE SIX VANTAUX
SCHIEBEFENSTER 2 FLUGEL
DOUBLE SLIDING WINDOW













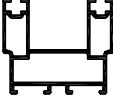

KOPPELINGEN	P. 89
COUPLAGES KUPPLUNGEN COUPLINGS	
UITSPARING VOOR RAILDOORGANG	P. 91
ENTAILLE POUR PASAGE RAIL EINBAU FÜR GLEISDURCHGANG EMBEDDING FOR RAILPASSAGE	
UITSPARING VOOR RAILDOORGANG / 3-DELIG	P. 94
ENTAILLE POUR PASAGE RAIL / 3 VANTAUX EINBAU FÜR GLEISDURCHGANG / 3 FLUGEL EMBEDDING FOR RAILPASSAGE / 3 PANELS	
UITSPARING VOOR ACSL010	P. 95
ENTAILLE POUR ACSL010 EINBAU FÜR ACSL010 EMBEDDING FOR ACSL010	
UITSPARING VOOR KOMGREEP	P. 96
ENTAILLE POUR CUVETTE EINBAU FÜR GRIFF EMBEDDING FOR GRIP	
UITSPARING VOOR DUBBELE HANDGREEP	P. 97
ENTAILLE POUR POIGNEE DOUBLE EINBAU FÜR DOPPELT HANDGRIFF EMBEDDING FOR DOUBLE HANDLE	
UITSPARING SL835	P. 98
ENTAILLES L835 EINBAU SL835 EMBEDDING SL835	
AFWATERING	P. 99
DRAINAGE ENTWASSERUNG DRAINAGE	
MONTAGE SCHROEFHOEK VOOR SL810	P. 100
MONTAGE CLAMES A VISSER POUR SL810 AUFSTELLEN ECKVERBINDERS SCHR SAUBBAR FÜR SL810 ASSEMBLY SQUARE COUPLING JOINTS FOR SL810	
MONTAGE ACSL047	P. 102
MONTAGE ACSL047 AUFSTELLEN ACSL047 ASSEMBLY ACSL047	
MONTAGE VLEUGEL	P. 103
MONTAGE OUVRANT AUFSTELLEN FLUGEL ASSEMBLY CASEMENT	

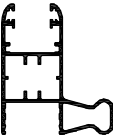
MONTAGE DUBBELE KOMGREEP _____	P. 104
MONTAGE CUVETTE DOUBLE AUFSTELLEN DOPPELT GRIFF ASSEMBLY DOUBLE GRIP	
MONTAGE KOMGREEP BINNEN _____	P. 105
MONTAGE CUVETTE INTERIEUR AUFSTELLEN GRIFT INNER ASSEMBLY GRIP INSIDE	
MONTAGE ACSL022 _____	P. 106
MONTAGE ACSL022 AUFSTELLEN ACSL022 ASSEMBLY ACSL022	
MONTAGE ACSL140 _____	P. 107
MONTAGE ACSL140 AUFSTELLEN ACSL140 ASSEMBLY ACSL140	
MONTAGE BUITENKADER _____	P. 108
MONTAGE DORMANT AUFSTELLEN RAHMEN ASSEMBLY OUTER FRAMES	

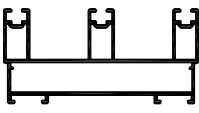





NUMMER NUMERO NUMBER	AFBEELDING IMAGE BILD PICTURE	BLAD PAGE SEITE PAGE	OMTREK PERIM. UMRIB PERIM. mm	MECH. MEC. MEC. mm	lx(cm4)	ly(cm4)	LENGTE LONG. LANGE LENGTH	VERP. PER EMB. PAR PACK PR.	BR	AN	KL	GS	M1
					Wx(cm3)	Wy(cm3)							
SL076		20	157.3	56	-	-	6,5	6	X	X	X	X	
SL810		13	315	168	20.44 6.95	12.8 5.16	6.5	2	X	X	X	X	
SL815		14	324	238	8.99 3.54	8.19 3.22	6.5	2	X	X	X	X	
SL820		16	348	149	6.45 4	13.52 3.73	4.5	2	X	X	X	X	
SL821		15	355	153	5.03 3.18	12.25 3.64	6.5	2	X	X	X	X	
SL830		17	234	121	5.95 2.78	4.18 2.32	4.5	2	X	X	X	X	
SL831		17	268	158	17.84 5.49	6.67 3.43	4.5	2	X	X	X	X	
SL833		18	257	126	4.34 2.75	6.75 2.24	6.5	2	X	X	X	X	
SL835		20	304	110	6.08 2.04	7.14 2.36	6.5	2	X	X	X	X	

BR = BRUT - BRUT - ROH - BRUT
 AN = ANODISATIE - ANODISE - ELOXIERT - ANODISED
 KL = STANDAARDKLEUREN - COULEUR STANDARD - BASIS FARBEN - BASIC COLORS
 GS = GEMOFFELD SPECIAAL - LAQUE SPECIAL - SPECIALFARBE - SPECIAL COLOR
 M1 = BICOLOR - BICOLOR - BICOLOR - BICOLOR

A = BUITEN - EXTERIEUR - AUSSEN - OUTSIDE
 B = BINNEN - INTERIEUR - INNEN - INSIDE

NUMMER NUMERO NUMBER	AFBEELDING IMAGE BILD PICTURE	BLAD PAGE SEITE PAGE	OMTREK PERIM. UMRIB PERIM. mm	MECH. MEC. MECH. MEC. mm	Ix(cm4)	Iy(cm4)	LENGTE LONG. LANGE LENGTH	VERP. PER EMB. PAR PACK PR.	BR	AN	KL	GS	M1
					Wx(cm3)	Wy(cm3)							
SL840	 	17	178	65	1.71 1.21	4.40 2.18	4.5	2	X	X	X	X	
SL870	 	20	215	157	6.20 2.17	0.47 0.45	6.5	6	X	X	X	X	
SL8110	 	13	359	213	20.78 7.07	11.48 4.72	6.5	2	X	X	X	X	
SL8120	 	16	401	202	15.48 4.29	19.96 6.54	4.5	2	X	X	X	X	
SL8311	 	14	527.5	390	91.67 17.69	16.96 6.68	6.5	2	X	X	X	X	
EL857	 	21	411.7	76	27.60 5.62	2.75 1.48	6.5	2	X	X	X	X	
SH071		20	84	23	-	-	6.5		X	X	X	X	
VG12		21	110	26	-	-	6.5	6	X	X	X	X	
VG52	 PVC	21	-	-	-	-	6.5	-					

BR = BRUT - BRUT - ROH - BRUT
AN = ANODISATIE - ANODISE - ELOXIERT - ANODISED
KL = STANDAARDKLEUREN - COULEUR STANDARD - BASIS FARBEN - BASIC COLORS
GS = GEMOFFELD SPECIAAL - LAQUE SPECIAL - SPECIALFARBE - SPECIAL COLOR
M1 = BICOLOR - BICOLOR - BICOLOR - BICOLOR

NUMMER NUMERO NUMMER NUMBER	AFBEELDING IMAGE BILD PICTURE	BLAD PAGE SEITE PAGE	OMTREK PERIM. UMRIB PERIM. mm	MECH. MEC. MEC. MEC. mm	lx(cm4)		LENGTE LONG. LANGE LENGTH	VERP. PER EMB. PAR PACK PR. PACK PR.	BR	AN	KL	GS	M1
					Wx(cm3)	Wy(cm3)							
VG53A		21	31.3	-	-	-	6.5	-		X			
VL479		19	162.9	83	-	-	6.5	2	X	X	X	X	
VL480		19	251.5	115	-	-	6.5	2	X	X	X	X	
VL481		19	311	147	-	-	6.5	2	X	X	X	X	
VL482		19	365.3	180.1	-	-	6.5	2	X	X	X	X	
VL483		19	425.5	209.7	-	-	6.5	2	X	X	X	X	
VL484		19	492.5	243	-	-	6.5	2	X	X	X	X	

SL810

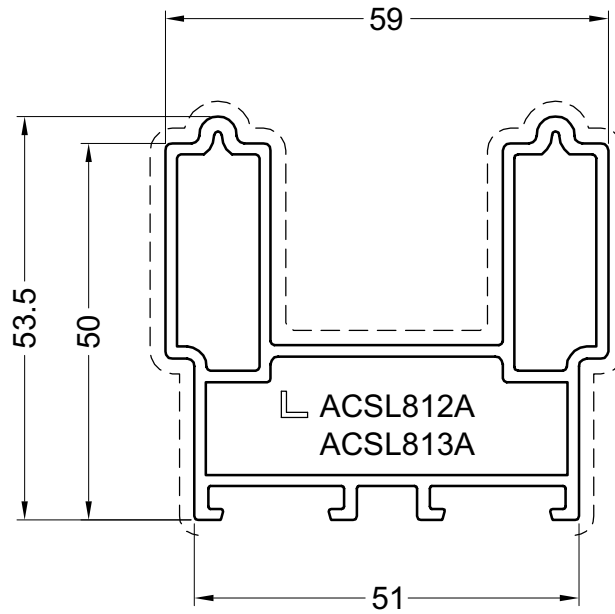

SL8110

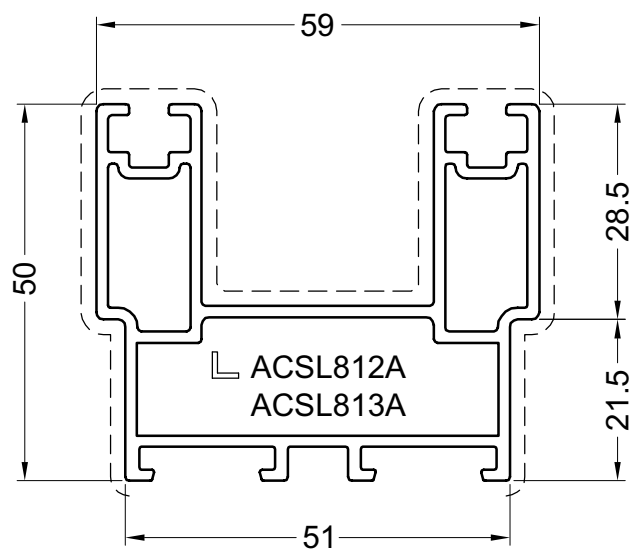

sla01

Primaire zichtbare zijde
Face visible primaire
Primär sichtbare Seite
Primary visible side

Secundaire zichtbare zijde
Face visible secondaire
Secondär sichtbare Seite
Secondary visible side

BUITENKADERS
PROFILS D'ENCADREMENT
KADERPRFOFILE
OUTER FRAMES

PROFIELEN - PROFILS- PROFILE - PROFILES

SL815

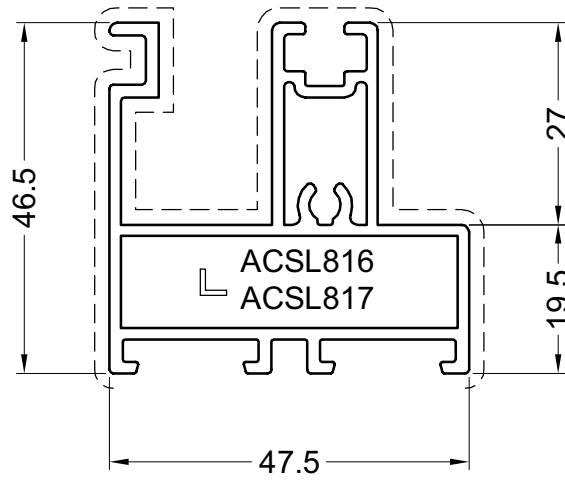

SL8311

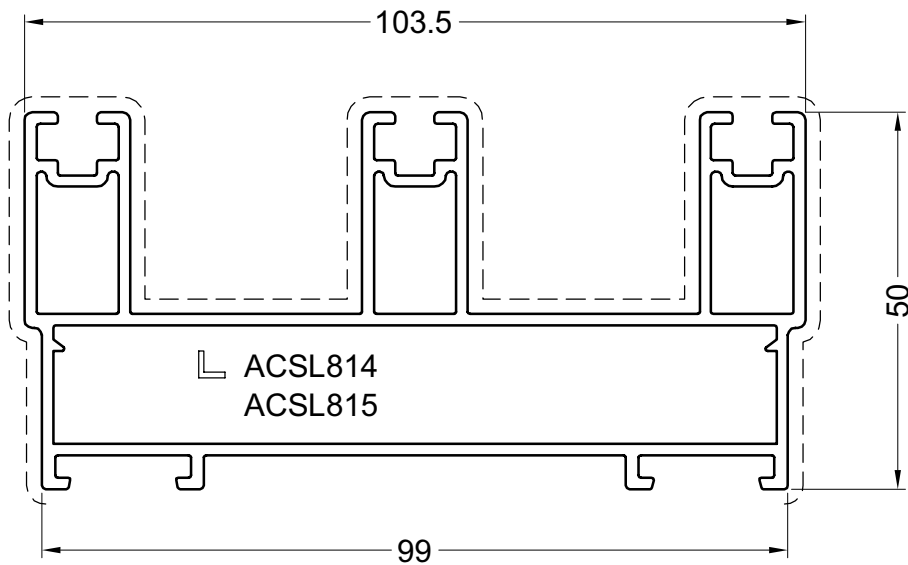

sla02

SL821

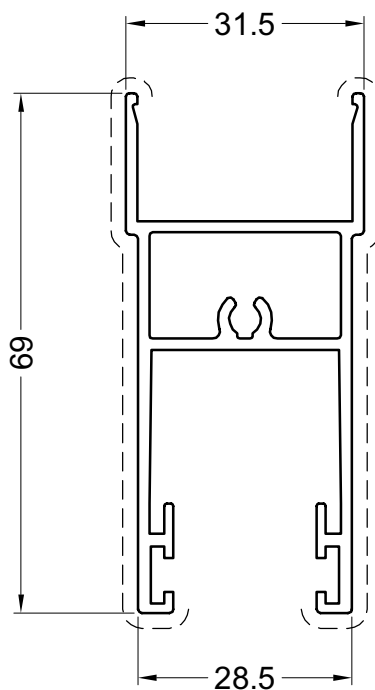

sla03

Primaire zichtbare zijde
Face visible primaire
Primär sichtbare Seite
Primary visible side

Secundaire zichtbare zijde
Face visible secondaire
Secondär sichtbare Seite
Secondary visible side

SL820

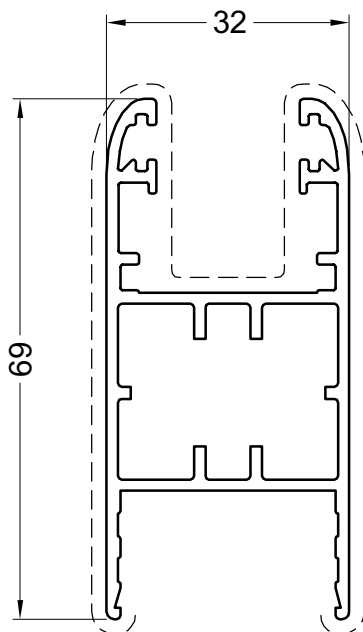

SL8120

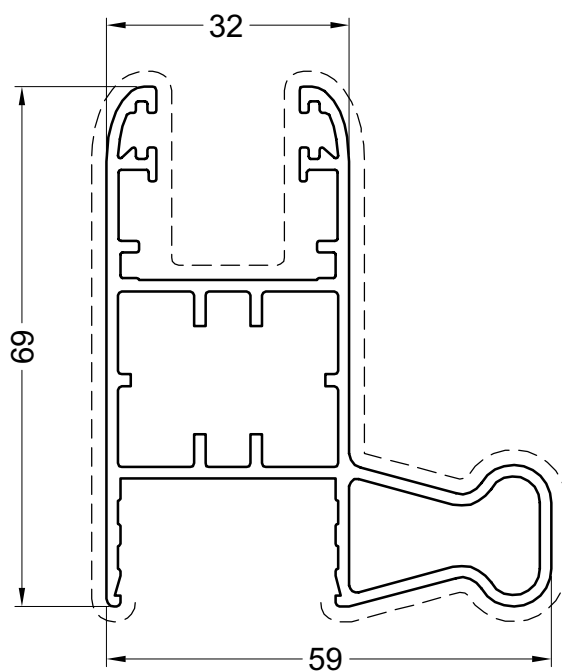

sla04

Primaire zichtbare zijde
Face visible primaire
Primär sichtbare Seite
Primary visible side

Secundaire zichtbare zijde
Face visible secondaire
Secondär sichtbare Seite
Secondary visible side

SL830

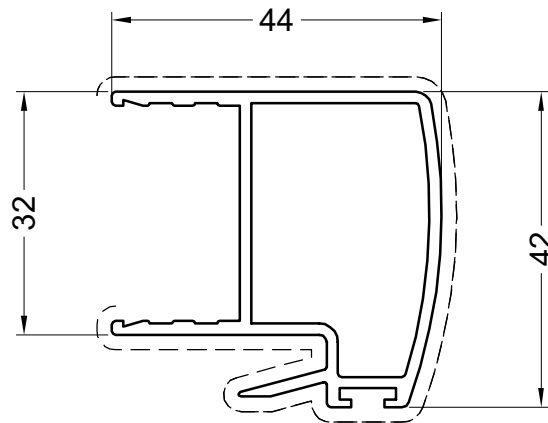

SL831

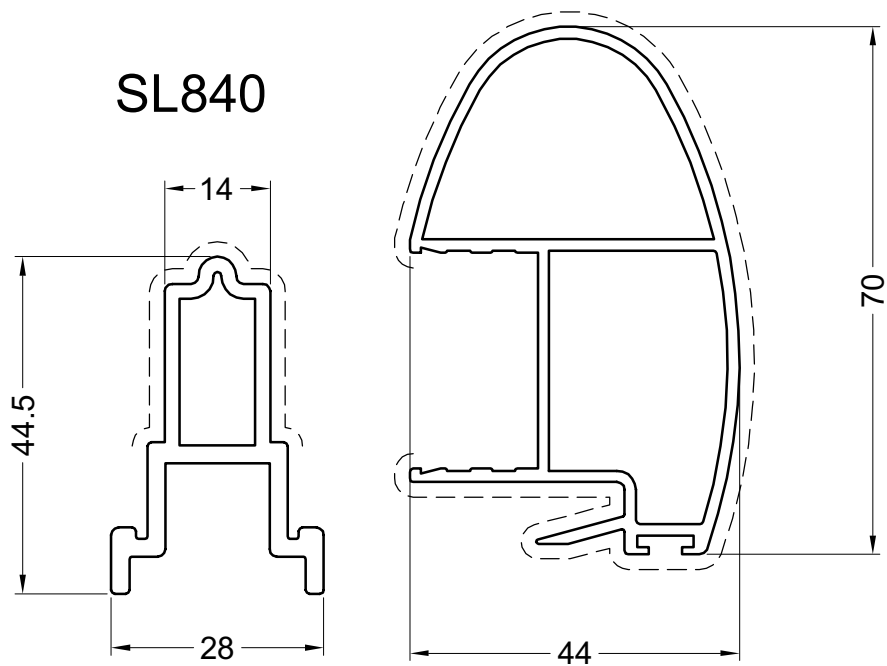

SL840

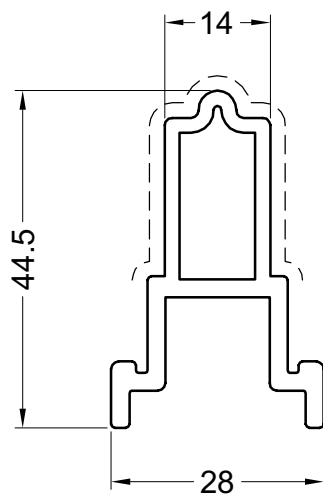

sla05

Primaire zichtbare zijde
Face visible primaire
Primär sichtbare Seite
Primary visible side

Secundaire zichtbare zijde
Face visible secondaire
Secondär sichtbare Seite
Secondary visible side

SL833

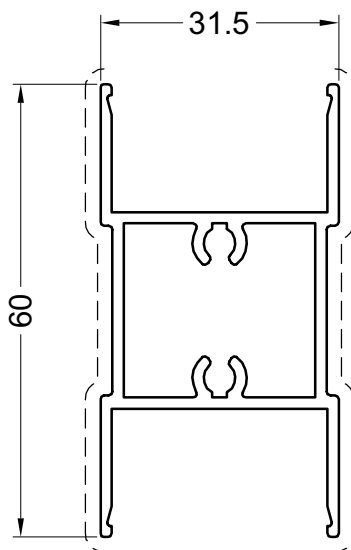

sla06

DORPELS
SEUIL
SOLL-PROFILE
SILL MEMBER

PROFIELEN - PROFILS- PROFILE - PROFILES

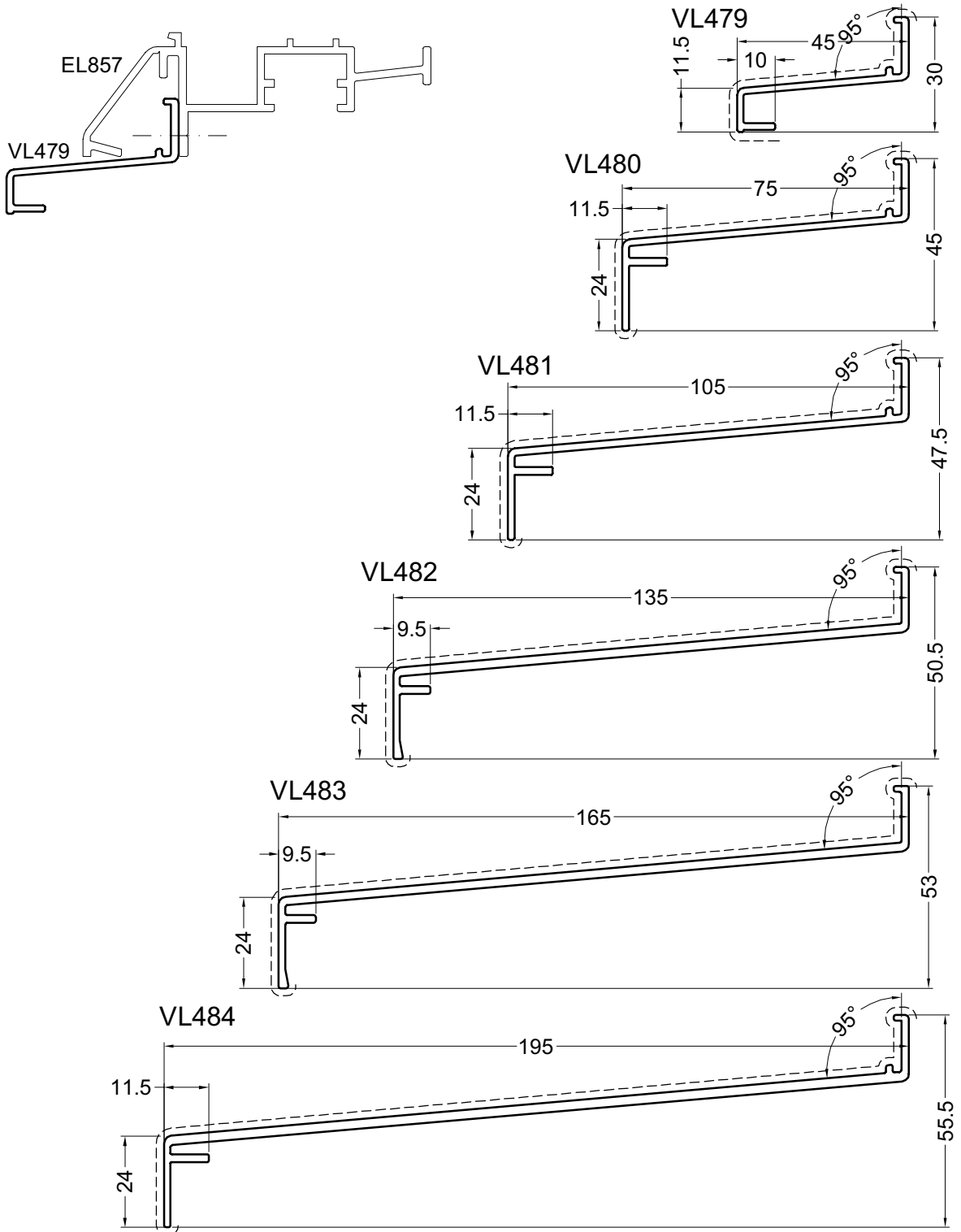

sla08

Primaire zichtbare zijde
Face visible primaire
Primär sichtbare Seite
Primary visible side

Secundaire zichtbare zijde
Face visible secondaire
Secondär sichtbare Seite
Secondary visible side

12/10/07

19

DIVERSE PROFIELEN
PROFILS DIVERS
DIVERS PROFILN
VARIED PROFILES

PROFIELEN - PROFILS - PROFILE - PROFILES

SL870

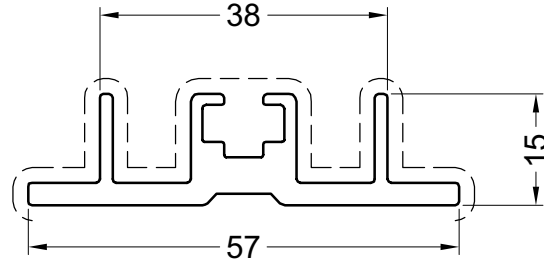

SL076

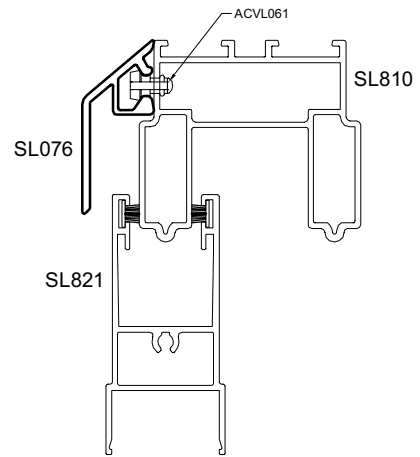
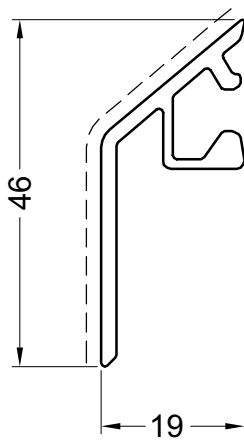

SL835

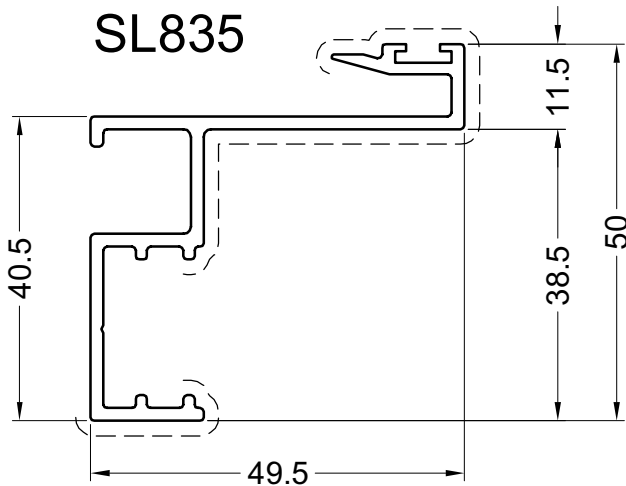

SH071

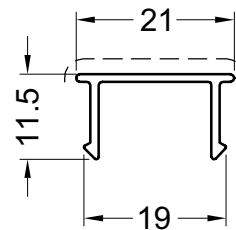

sla09

DIVERSE PROFIELEN
PROFILS DIVERS
DIVERS PROFILN
VARIED PROFILES

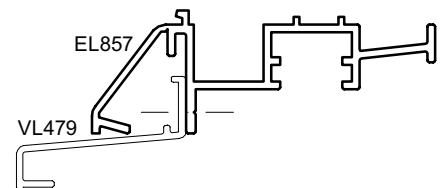
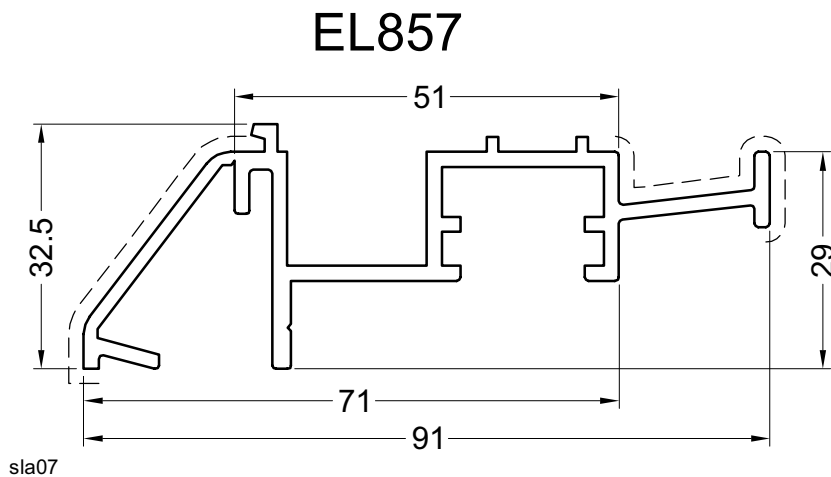
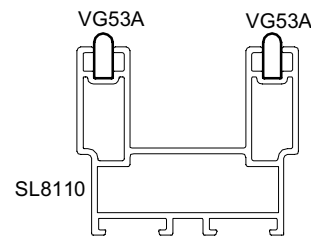
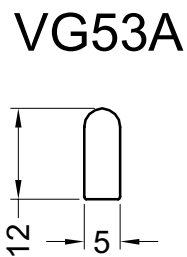
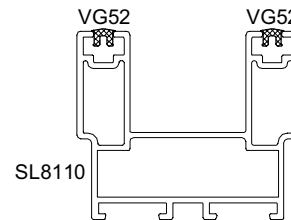
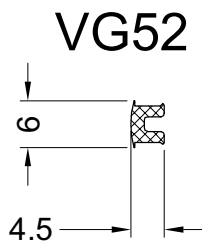
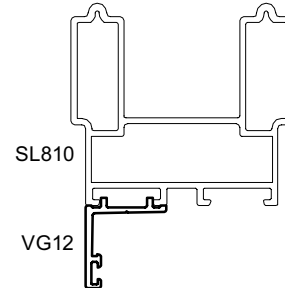
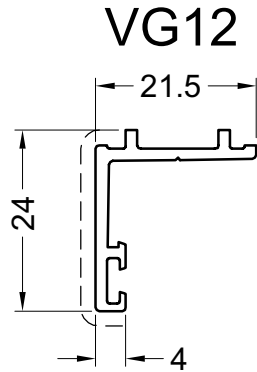

PROFIELEN - PROFILS - PROFILE - PROFILES



sla07

Primaire zichtbare zijde
Face visible primaire
Primär sichtbare Seite
Primary visible side

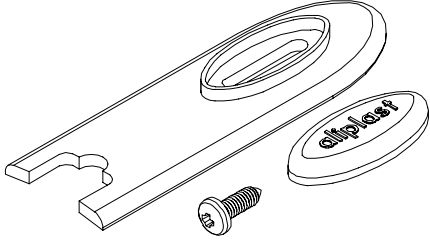
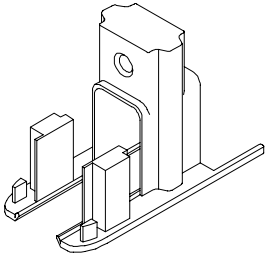
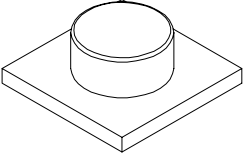
Secundaire zichtbare zijde
Face visible secondaire
Secondär sichtbare Seite
Secondary visible side

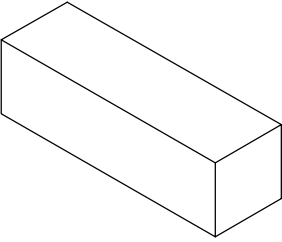
		Verp. per Emb. par Pack pr.	Einheid Unité Einheit Unit	Toepassing Application Anwendung Application	Kleur Couleur Farbe Color												
	ACSL020 -Sluitstuk raildoorgang -Closoir passage rail -Abdeckkappe -Central plug	1	Stuk Pièce Stück Pièce	SL830 SL831	<table border="1"> <tr><td>BR</td><td></td></tr> <tr><td>AN</td><td></td></tr> <tr><td>KL</td><td></td></tr> <tr><td>GS</td><td></td></tr> <tr><td>Z</td><td>X</td></tr> <tr><td>W</td><td>X</td></tr> </table>	BR		AN		KL		GS		Z	X	W	X
BR																	
AN																	
KL																	
GS																	
Z	X																
W	X																
	ACSL021 -Eindstuk -Embout -End Stück -Sealing member	1	Stuk Pièce Stück Pièce	SL820 SL8120	<table border="1"> <tr><td>BR</td><td></td></tr> <tr><td>AN</td><td></td></tr> <tr><td>KL</td><td></td></tr> <tr><td>GS</td><td></td></tr> <tr><td>Z</td><td>X</td></tr> <tr><td>W</td><td>X</td></tr> </table>	BR		AN		KL		GS		Z	X	W	X
BR																	
AN																	
KL																	
GS																	
Z	X																
W	X																
	ACSL022 -Sluitstootbuffer -Butée de fermeture -Stossklotz -Stop block	1	Stuk Pièce Stück Pièce	SL820 SL8120	<table border="1"> <tr><td>BR</td><td></td></tr> <tr><td>AN</td><td></td></tr> <tr><td>KL</td><td></td></tr> <tr><td>GS</td><td></td></tr> <tr><td>Z</td><td>X</td></tr> <tr><td>W</td><td></td></tr> </table>	BR		AN		KL		GS		Z	X	W	
BR																	
AN																	
KL																	
GS																	
Z	X																
W																	
	ACSL024 -Afdekkapje waterafvoer -Capuchon écoulement d'eau -Abdeckkappe entwässerung -Drain hole cover	1	Stuk Pièce Stück Pièce	SL810 SL8110 SL8311	<table border="1"> <tr><td>BR</td><td></td></tr> <tr><td>AN</td><td></td></tr> <tr><td>KL</td><td>X</td></tr> <tr><td>GS</td><td></td></tr> <tr><td>Z</td><td>X</td></tr> <tr><td>W</td><td>X</td></tr> </table>	BR		AN		KL	X	GS		Z	X	W	X
BR																	
AN																	
KL	X																
GS																	
Z	X																
W	X																
	ACSL025 -Anti-uithefstuk -Pièce anti-dégondage -Aushebe sperre -Lift-out security	1	Stuk Pièce Stück Pièce	SL810	<table border="1"> <tr><td>BR</td><td>X</td></tr> <tr><td>AN</td><td></td></tr> <tr><td>KL</td><td></td></tr> <tr><td>GS</td><td></td></tr> <tr><td>Z</td><td></td></tr> <tr><td>W</td><td></td></tr> </table>	BR	X	AN		KL		GS		Z		W	
BR	X																
AN																	
KL																	
GS																	
Z																	
W																	

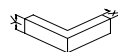

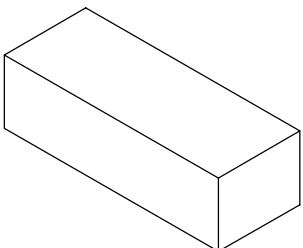
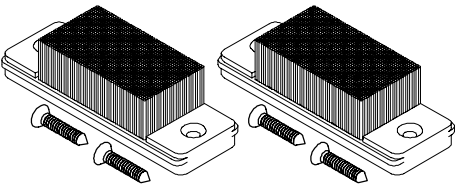
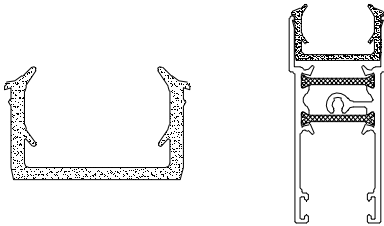
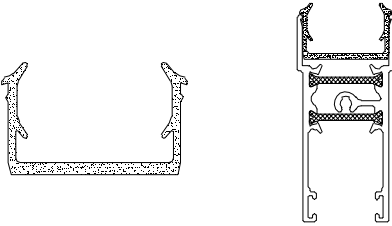
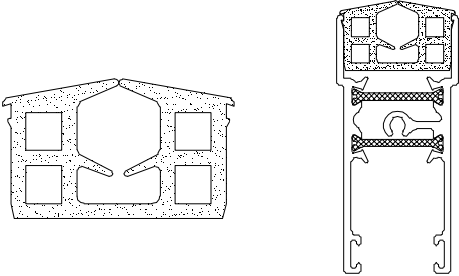
		Verp. per Emb. par Pack pr. Pack pr.	Eenheid Unité Einheit Unit	Toepassing Application Anwendung Application	Kleur Couleur Farbe Color												
	ACSL026 -Anti-uithefstuk -Pièce anti-dégondage -Aushebe sperre -Lift-out security	1	Stuk Pièce Stück Pièce	SL8110	<table border="1"> <tr><td>BR</td><td>X</td></tr> <tr><td>AN</td><td></td></tr> <tr><td>KL</td><td></td></tr> <tr><td>GS</td><td></td></tr> <tr><td>Z</td><td></td></tr> <tr><td>W</td><td></td></tr> </table>	BR	X	AN		KL		GS		Z		W	
BR	X																
AN																	
KL																	
GS																	
Z																	
W																	
	ACSL030 -Centrale dichting onder+boven -Étanchéité centrale inf. et sup. -Mitteldichtung unten und oben -Plug for risers and antidust top and bottom	1	Set	SL810 SL8110 SL8311	<table border="1"> <tr><td>BR</td><td></td></tr> <tr><td>AN</td><td></td></tr> <tr><td>KL</td><td></td></tr> <tr><td>GS</td><td></td></tr> <tr><td>Z</td><td>X</td></tr> <tr><td>W</td><td></td></tr> </table>	BR		AN		KL		GS		Z	X	W	
BR																	
AN																	
KL																	
GS																	
Z	X																
W																	
	ACSL031 -Beglazingsrubber voor glas 20-21mm -Joint de vitrage pour verre 20-21mm -Glasdichtung für glas 20-21mm -Glazing gasket for glass 20-21mm	50	m	SL820 SL821 SL830 SL831 SL833 SL8120	<table border="1"> <tr><td>BR</td><td></td></tr> <tr><td>AN</td><td></td></tr> <tr><td>KL</td><td></td></tr> <tr><td>GS</td><td></td></tr> <tr><td>Z</td><td>X</td></tr> <tr><td>W</td><td></td></tr> </table>	BR		AN		KL		GS		Z	X	W	
BR																	
AN																	
KL																	
GS																	
Z	X																
W																	
	ACSL032 -Beglazingsrubber voor glas 22-23-24mm -Joint de vitrage pour verre de 22-23-24mm -Glasdichtung für glas 22-23-24mm -Glazing gasket for glass 22-23-24mm	50	m	SL820 SL821 SL830 SL831 SL833 SL8120	<table border="1"> <tr><td>BR</td><td></td></tr> <tr><td>AN</td><td></td></tr> <tr><td>KL</td><td></td></tr> <tr><td>GS</td><td></td></tr> <tr><td>Z</td><td>X</td></tr> <tr><td>W</td><td></td></tr> </table>	BR		AN		KL		GS		Z	X	W	
BR																	
AN																	
KL																	
GS																	
Z	X																
W																	
	ACSL033 -Beglazingsrubber voor glas 6-9mm -Joint de vitrage pour verre 6-9mm -Glasdichtung für glas 6-9mm -Glazing gasket for glass 6-9mm	50	m	SL820 SL821 SL830 SL831 SL833 SL8120	<table border="1"> <tr><td>BR</td><td></td></tr> <tr><td>AN</td><td></td></tr> <tr><td>KL</td><td></td></tr> <tr><td>GS</td><td></td></tr> <tr><td>Z</td><td>X</td></tr> <tr><td>W</td><td></td></tr> </table>	BR		AN		KL		GS		Z	X	W	
BR																	
AN																	
KL																	
GS																	
Z	X																
W																	

BR = BRUT - BRUT - ROH - BRUT
AN (X) = ANODISATIE - ANODISE - ELOXIERT - ANODISED
AN (■) = GELAKT - LAQUE - LACKIERT - LACQUERED -- RAL9006M
KL = STANDAARDKLEUREN - COULEUR STANDARD - BASIS FARBEN - BASIC COLORS
GS = GEMOFFELD SPECIAAL - LAQUE SPECIAL - SPECIALFARBE - SPECIAL COLOR
Z = ZWART - NOIR - SCHWARZ - BLACK
W = WIT - BLANC - WEISS - WHITE





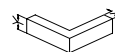

GEREEDSCHAP - OUTILLAGE
WERKZEUG - TOOL

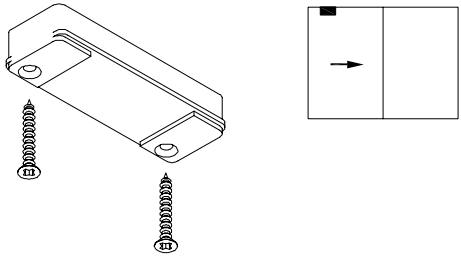
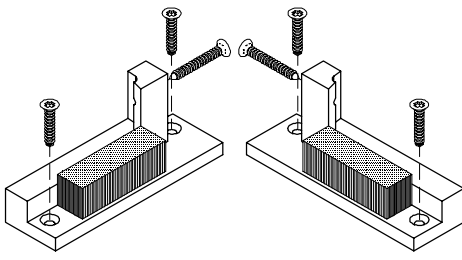
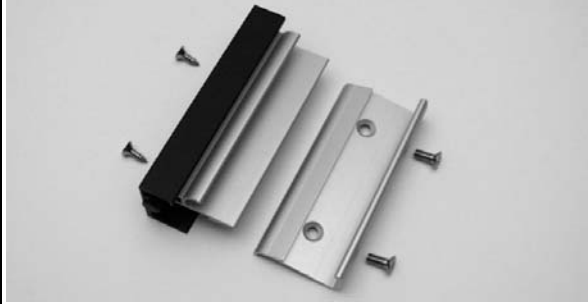
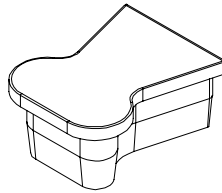
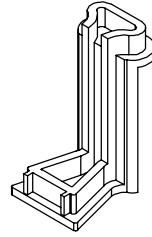
BEVESTIGING - FIXATION
BEFESTIGUNG - FIXATION

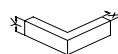

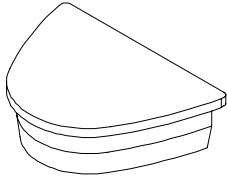
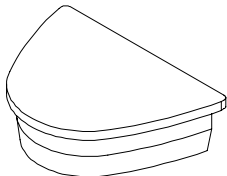
	Verp. per Emb. par Pack pr.	Einheid Unité Einheit Unit	Toepassing Application Anwendung Application	Kleur Couleur Farbe Color												
 <p>ACSL035 -Anti-uithefstuk -Pièce anti dégon dage -Aushebe sperre -Lift-out security</p>	1	Stuk Pièce Stück Pièce	SL810 SL8110 SL8311	<table border="1"> <tr><td>BR</td><td></td></tr> <tr><td>AN</td><td></td></tr> <tr><td>KL</td><td></td></tr> <tr><td>GS</td><td></td></tr> <tr><td>Z</td><td>X</td></tr> <tr><td>W</td><td></td></tr> </table>	BR		AN		KL		GS		Z	X	W	
BR																
AN																
KL																
GS																
Z	X															
W																
 <p>ACSL037 -Steun voor vaste kader -Support pour cadre fixe -Klotz für feste rahmen -Support for fixed frame</p>	1	Stuk Pièce Stück Pièce	SL810 SL8110 SL8311	<table border="1"> <tr><td>BR</td><td>X</td></tr> <tr><td>AN</td><td></td></tr> <tr><td>KL</td><td></td></tr> <tr><td>GS</td><td></td></tr> <tr><td>Z</td><td></td></tr> <tr><td>W</td><td></td></tr> </table>	BR	X	AN		KL		GS		Z		W	
BR	X															
AN																
KL																
GS																
Z																
W																
 <p>ACSL048 -Clickmatic 2de vleugel -Clickmatic 2ième vantail -Clickmatic zweiter flügel -Clickmatic 2nd vent</p>	1	Stuk Pièce Stück Pièce	SL820	<table border="1"> <tr><td>BR</td><td>X</td></tr> <tr><td>AN</td><td>X</td></tr> <tr><td>KL</td><td>X</td></tr> <tr><td>GS</td><td>X</td></tr> <tr><td>Z</td><td>X</td></tr> <tr><td>W</td><td>X</td></tr> </table>	BR	X	AN	X	KL	X	GS	X	Z	X	W	X
BR	X															
AN	X															
KL	X															
GS	X															
Z	X															
W	X															
 <p>ACSL120 -Eindstuk -Embout -endstück -Sealing member</p>	1	Stuk Pièce Stück Pièce	SL8120	<table border="1"> <tr><td>BR</td><td></td></tr> <tr><td>AN</td><td></td></tr> <tr><td>KL</td><td></td></tr> <tr><td>GS</td><td></td></tr> <tr><td>Z</td><td>X</td></tr> <tr><td>W</td><td>X</td></tr> </table>	BR		AN		KL		GS		Z	X	W	X
BR																
AN																
KL																
GS																
Z	X															
W	X															
 <p>ACSL121 -Eindstuk -Embout -Endstück -Sealing member</p>	1	Stuk Pièce Stück Pièce	SL8120	<table border="1"> <tr><td>BR</td><td></td></tr> <tr><td>AN</td><td></td></tr> <tr><td>KL</td><td></td></tr> <tr><td>GS</td><td></td></tr> <tr><td>Z</td><td>X</td></tr> <tr><td>W</td><td>X</td></tr> </table>	BR		AN		KL		GS		Z	X	W	X
BR																
AN																
KL																
GS																
Z	X															
W	X															



		Verp. per Emb. par Pack pr. Pack pr.	Eenheid Unité Einheit Unit	Toepassing Application Anwendung Application	Kleur Couleur Farbe Color												
	ACSL131 -Eindstuk -Embout -Endstück -Sealing member	1	Stuk Pièce Stück Pièce	SL831	<table border="1"> <tr><td>BR</td><td></td></tr> <tr><td>AN</td><td></td></tr> <tr><td>KL</td><td></td></tr> <tr><td>GS</td><td></td></tr> <tr><td>Z</td><td>X</td></tr> <tr><td>W</td><td>X</td></tr> </table>	BR		AN		KL		GS		Z	X	W	X
BR																	
AN																	
KL																	
GS																	
Z	X																
W	X																
	ACSL132 -Eindstuk / 3-delig -Embout / 3 vantaux -Endstück / 3 Flügel -Sealing member / 3 panel	1	Stuk Pièce Stück Pièce	SL831	<table border="1"> <tr><td>BR</td><td></td></tr> <tr><td>AN</td><td></td></tr> <tr><td>KL</td><td></td></tr> <tr><td>GS</td><td></td></tr> <tr><td>Z</td><td>X</td></tr> <tr><td>W</td><td>X</td></tr> </table>	BR		AN		KL		GS		Z	X	W	X
BR																	
AN																	
KL																	
GS																	
Z	X																
W	X																
	ACSL134 -Pakket schroeven voor handgrepen -Paquet de vis pour poignée fenêtre -Paket Schrauben für Handgriff -Set screws for handle	1	Stuk Pièce Stück Pièce	ACSL135 ACSL136 ACSL137 ACSL138	<table border="1"> <tr><td>BR</td><td>X</td></tr> <tr><td>AN</td><td></td></tr> <tr><td>KL</td><td></td></tr> <tr><td>GS</td><td></td></tr> <tr><td>Z</td><td></td></tr> <tr><td>W</td><td></td></tr> </table>	BR	X	AN		KL		GS		Z		W	
BR	X																
AN																	
KL																	
GS																	
Z																	
W																	
	ACSL135 -Vaste handgreep buiten met cilinder voor 4 slag -Poignée fixe extérieure avec cylindre pour 4 vantaux -Feste Handgriff aussen mit Zylinder für 4 Flügel -fixed handle outside with cylinder for 4 vent	1	Stuk Pièce Stück Pièce	SL820	<table border="1"> <tr><td>BR</td><td>X</td></tr> <tr><td>AN</td><td>X</td></tr> <tr><td>KL</td><td>X</td></tr> <tr><td>GS</td><td>X</td></tr> <tr><td>Z</td><td></td></tr> <tr><td>W</td><td></td></tr> </table>	BR	X	AN	X	KL	X	GS	X	Z		W	
BR	X																
AN	X																
KL	X																
GS	X																
Z																	
W																	
	ACSL136 -Handgreep binnen voor 4 slag -Poignée intérieure pour 4 vantaux -Handgriff inner für 4 Flügel -Handle inside for 4 vent	1	Stuk Pièce Stück Pièce	SL820	<table border="1"> <tr><td>BR</td><td>X</td></tr> <tr><td>AN</td><td>X</td></tr> <tr><td>KL</td><td>X</td></tr> <tr><td>GS</td><td>X</td></tr> <tr><td>Z</td><td></td></tr> <tr><td>W</td><td></td></tr> </table>	BR	X	AN	X	KL	X	GS	X	Z		W	
BR	X																
AN	X																
KL	X																
GS	X																
Z																	
W																	

BR = BRUT - BRUT - ROH - BRUT
AN (X) = ANODISATIE - ANODISE - ELOXIERT - ANODISED
AN (■) = GELAKT - LAQUE - LACKIERT - LACQUERED -- RAL9006M
KL = STANDAARDKLEUREN - COULEUR STANDARD - BASIS FARBEN - BASIC COLORS
GS = GEMOFFELD SPECIAAL - LAQUE SPECIAL - SPECIALFARBE - SPECIAL COLOR
Z = ZWART - NOIR - SCHWARZ - BLACK
W = WIT - BLANC - WEISS - WHITE



GEREEDSCHAP - OUTILLAGE
WERKZEUG - TOOL



BEVESTIGING - FIXATION
BEFESTIGUNG - FIXATION

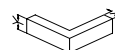

	Verp. per Emb. par Pack pr.	Einheid Unit	Toepassing Application	Kleur Couleur												
 <p>ACSL137 -Vaste handgreep buiten voor 4 slag -Poignée fixe extérieure pour 4 vantaux -Feste Handgriff aussen für 4 Flügel -Fixed handle outside for 4 vent</p> <p>➤ ACSL134</p>	1	Stuk Pièce Stück Piece	SL820	<table border="1"> <tr><td>BR</td><td>X</td></tr> <tr><td>AN</td><td>X</td></tr> <tr><td>KL</td><td>X</td></tr> <tr><td>GS</td><td>X</td></tr> <tr><td>Z</td><td></td></tr> <tr><td>W</td><td></td></tr> </table>	BR	X	AN	X	KL	X	GS	X	Z		W	
BR	X															
AN	X															
KL	X															
GS	X															
Z																
W																
 <p>ACSL138 -Vaste handgreep binnen voor 4 slag -Poignée fixe intérieure pour 4 vantaux -Feste Handgriff inner für 4 Flügel -Fixed handle inside for 4 vent</p> <p>➤ ACSL134</p>	1	Stuk Pièce Stück Piece	SL820	<table border="1"> <tr><td>BR</td><td>X</td></tr> <tr><td>AN</td><td>X</td></tr> <tr><td>KL</td><td>X</td></tr> <tr><td>GS</td><td>X</td></tr> <tr><td>Z</td><td></td></tr> <tr><td>W</td><td></td></tr> </table>	BR	X	AN	X	KL	X	GS	X	Z		W	
BR	X															
AN	X															
KL	X															
GS	X															
Z																
W																
 <p>ACSL140 -Eindstuk -Embout -Endstück -End piece</p>	1	Set	SL840	<table border="1"> <tr><td>BR</td><td></td></tr> <tr><td>AN</td><td></td></tr> <tr><td>KL</td><td></td></tr> <tr><td>GS</td><td></td></tr> <tr><td>Z</td><td>X</td></tr> <tr><td>W</td><td>X</td></tr> </table>	BR		AN		KL		GS		Z	X	W	X
BR																
AN																
KL																
GS																
Z	X															
W	X															
 <p>ACSL235 -Sluïting schuifdeur -Fermeture coulissant -Handhabe Schiebetür -Handle for sliding door</p>	1	Set	SL820	<table border="1"> <tr><td>BR</td><td></td></tr> <tr><td>AN</td><td></td></tr> <tr><td>KL</td><td></td></tr> <tr><td>GS</td><td></td></tr> <tr><td>Z</td><td>X</td></tr> <tr><td>W</td><td>X</td></tr> </table>	BR		AN		KL		GS		Z	X	W	X
BR																
AN																
KL																
GS																
Z	X															
W	X															
 <p>ACSL239 -Anti-foutbediening -Anti-fausse manoeuvre -Anti falsch bedienung -Anti handling device operation</p>	1	Stuk Pièce Stück Piece	ACSL240XX ACSL242XX ACSL243XX	<table border="1"> <tr><td>BR</td><td></td></tr> <tr><td>AN</td><td></td></tr> <tr><td>KL</td><td></td></tr> <tr><td>GS</td><td></td></tr> <tr><td>Z</td><td></td></tr> <tr><td>W</td><td></td></tr> </table>	BR		AN		KL		GS		Z		W	
BR																
AN																
KL																
GS																
Z																
W																



		Verp. per Emb. par Pack pr. Pack pr.	Eenheid Unité Einheit Unit	Toepassing Application Anwendung Application	Kleur Couleur Farbe Color												
	ACSL240 -Kongreep binnen -Cuvette intérieur -Griff inner -Grip inside	1	Stuk Pièce Stück Pièce	SL820 SL8120	<table border="1"> <tr><td>BR</td><td></td></tr> <tr><td>AN</td><td></td></tr> <tr><td>KL</td><td>X</td></tr> <tr><td>GS</td><td>X</td></tr> <tr><td>Z</td><td></td></tr> <tr><td>W</td><td>X</td></tr> </table>	BR		AN		KL	X	GS	X	Z		W	X
BR																	
AN																	
KL	X																
GS	X																
Z																	
W	X																
	ACSL242 -Dubbele kongreep -Cuvette double -Griff doppelt -Grip double	1	Stuk Pièce Stück Pièce	SL820 SL8120	<table border="1"> <tr><td>BR</td><td></td></tr> <tr><td>AN</td><td></td></tr> <tr><td>KL</td><td>X</td></tr> <tr><td>GS</td><td>X</td></tr> <tr><td>Z</td><td></td></tr> <tr><td>W</td><td>X</td></tr> </table>	BR		AN		KL	X	GS	X	Z		W	X
BR																	
AN																	
KL	X																
GS	X																
Z																	
W	X																
	ACSL243 -Dubbele kongreep met cilinder -Cuvette double avec cylindre -Griff doppelt mit Zylinder -Grip double with cilinder	1	Stuk Pièce Stück Pièce	SL820 SL8120	<table border="1"> <tr><td>BR</td><td></td></tr> <tr><td>AN</td><td></td></tr> <tr><td>KL</td><td>X</td></tr> <tr><td>GS</td><td>X</td></tr> <tr><td>Z</td><td></td></tr> <tr><td>W</td><td>X</td></tr> </table>	BR		AN		KL	X	GS	X	Z		W	X
BR																	
AN																	
KL	X																
GS	X																
Z																	
W	X																
	ACSL245 -Handgreep binnen -Poignée de tirage intérieur -Handgriff inner -Handle inside	1	Stuk Pièce Stück Pièce	ACSL240 ACSL242 ACSL243	<table border="1"> <tr><td>BR</td><td></td></tr> <tr><td>AN</td><td></td></tr> <tr><td>KL</td><td>X</td></tr> <tr><td>GS</td><td>X</td></tr> <tr><td>Z</td><td></td></tr> <tr><td>W</td><td>X</td></tr> </table>	BR		AN		KL	X	GS	X	Z		W	X
BR																	
AN																	
KL	X																
GS	X																
Z																	
W	X																
	ACSL246 -Slotplaat -Gache -Schliesplatte -Lock plate	1	Stuk Pièce Stück Pièce	SL820 SL8120 SL8110 SL815 SL8311	<table border="1"> <tr><td>BR</td><td></td></tr> <tr><td>AN</td><td></td></tr> <tr><td>KL</td><td></td></tr> <tr><td>GS</td><td></td></tr> <tr><td>Z</td><td></td></tr> <tr><td>W</td><td></td></tr> </table>	BR		AN		KL		GS		Z		W	
BR																	
AN																	
KL																	
GS																	
Z																	
W																	



BR = BRUT - BRUT - ROH - BRUT
AN (X) = ANODISATIE - ANODISE - ELOXIERT - ANODISED
AN (■) = GELAKT - LAQUE - LACKIERT - LACQUERED -- RAL9006M
KL = STANDAARDKLEUREN - COULEUR STANDARD - BASIS FARBEN - BASIC COLORS
GS = GEMOFFELD SPECIAAL - LAQUE SPECIAL - SPECIALFARBE - SPECIAL COLOR
Z = ZWART - NOIR - SCHWARZ - BLACK
W = WIT - BLANC - WEISS - WHITE





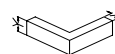

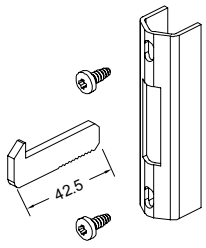
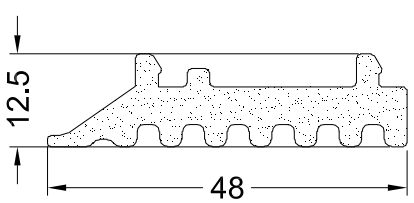
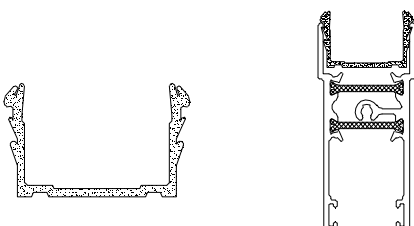
GEREEDSCHAP - OUTILLAGE
WERKZEUG - TOOL

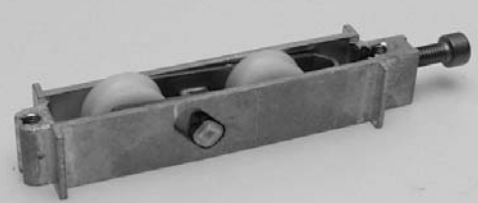
BEVESTIGING - FIXATION
BEFESTIGUNG - FIXATION

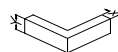

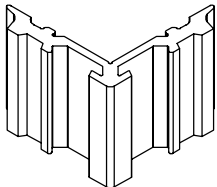
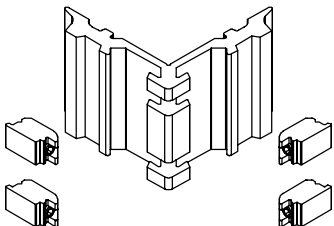
		Verp. per Emb. par Pack pr.	Einheid Unité Einheit Unit	Toepassing Application Anwendung Application	Kleur Couleur Farbe Color												
	<p>ACSL248</p> <ul style="list-style-type: none"> -Slotplaat -Gache -Schliesplatte -Lock plate 	1	Stuk Pièce Stück Pièce	SL810 ACSL240 ACSL242 ACSL243	<table border="1"> <tr><td>BR</td><td></td></tr> <tr><td>AN</td><td></td></tr> <tr><td>KL</td><td></td></tr> <tr><td>GS</td><td></td></tr> <tr><td>Z</td><td></td></tr> <tr><td>W</td><td></td></tr> </table>	BR		AN		KL		GS		Z		W	
BR																	
AN																	
KL																	
GS																	
Z																	
W																	
	<p>ACSL300</p> <ul style="list-style-type: none"> -Basis rubber -Gache de base -Basis Gummi -Base rubber 	1	Stuk Pièce Stück Pièce	SL810 SL8110 SL8311	<table border="1"> <tr><td>BR</td><td></td></tr> <tr><td>AN</td><td></td></tr> <tr><td>KL</td><td></td></tr> <tr><td>GS</td><td></td></tr> <tr><td>Z</td><td>X</td></tr> <tr><td>W</td><td></td></tr> </table>	BR		AN		KL		GS		Z	X	W	
BR																	
AN																	
KL																	
GS																	
Z	X																
W																	
	<p>ACSL332</p> <ul style="list-style-type: none"> -Beglazingsrubber voor glas 24mm -Joint de vitrage pour verre 24mm -Glasdichtung für glas 24mm -Glazing gasket for glass 24mm 	50	m	SL820 SL821 SL830 SL831 SL833 SL8120	<table border="1"> <tr><td>BR</td><td></td></tr> <tr><td>AN</td><td></td></tr> <tr><td>KL</td><td></td></tr> <tr><td>GS</td><td></td></tr> <tr><td>Z</td><td>X</td></tr> <tr><td>W</td><td></td></tr> </table>	BR		AN		KL		GS		Z	X	W	
BR																	
AN																	
KL																	
GS																	
Z	X																
W																	
	<p>ACSL810</p> <ul style="list-style-type: none"> -Enkel loopwiel vast - max. 40kg/wiel -Roulette simple fixe - max. 40kg/roul. -Rolle fest - max. 40kg/Rolle -Fixed pulley - max. 40kg/pulley 	1	Stuk Pièce Stück Pièce	SL821	<table border="1"> <tr><td>BR</td><td>X</td></tr> <tr><td>AN</td><td></td></tr> <tr><td>KL</td><td></td></tr> <tr><td>GS</td><td></td></tr> <tr><td>Z</td><td></td></tr> <tr><td>W</td><td></td></tr> </table>	BR	X	AN		KL		GS		Z		W	
BR	X																
AN																	
KL																	
GS																	
Z																	
W																	
	<p>ACSL811</p> <ul style="list-style-type: none"> -Regelbaar tandemwiel - max. 80kg -Chariot double réglable - max. 80kg -Tandemrolle regelbaar - max. 80kg -Adjustable double pulley - max. 80kg 	1	Stuk Pièce Stück Pièce	SL821	<table border="1"> <tr><td>BR</td><td>X</td></tr> <tr><td>AN</td><td></td></tr> <tr><td>KL</td><td></td></tr> <tr><td>GS</td><td></td></tr> <tr><td>Z</td><td></td></tr> <tr><td>W</td><td></td></tr> </table>	BR	X	AN		KL		GS		Z		W	
BR	X																
AN																	
KL																	
GS																	
Z																	
W																	

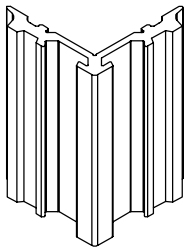
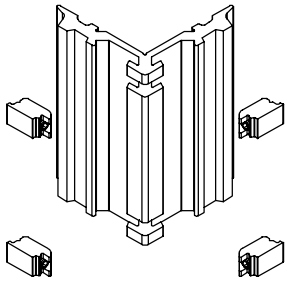

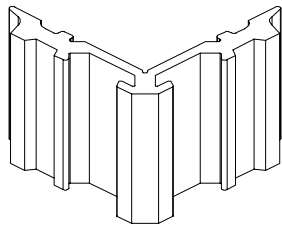
		Verp. per Emb. par Pack pr. Pack pr.	Eenheid Unité Einheit Unit	Toepassing Application Anwendung Application	Kleur Couleur Farbe Color											
 <p>ACSL812A -Pershoek -Clame à presser -Eckverbinder stanzbar -Clamping corner</p> <p>X=12mm Y=48mm</p>	1	Stuk Pièce Stück Pièce	SL810 SL8110	<table border="1"> <tr><td>BR</td><td>X</td></tr> <tr><td>AN</td><td></td></tr> <tr><td>KL</td><td></td></tr> <tr><td>GS</td><td></td></tr> <tr><td>Z</td><td></td></tr> <tr><td>W</td><td></td></tr> </table>	BR	X	AN		KL		GS		Z		W	
BR	X															
AN																
KL																
GS																
Z																
W																
 <p>ACSL813A -Schroefhoek -Clame à visser -Eckverbinder schraubbar -Square coupling joint</p> <p>X=12mm Y=48mm</p>  ACVG66	1	Stuk Pièce Stück Pièce	SL810 SL8110	<table border="1"> <tr><td>BR</td><td>X</td></tr> <tr><td>AN</td><td></td></tr> <tr><td>KL</td><td></td></tr> <tr><td>GS</td><td></td></tr> <tr><td>Z</td><td></td></tr> <tr><td>W</td><td></td></tr> </table>	BR	X	AN		KL		GS		Z		W	
BR	X															
AN																
KL																
GS																
Z																
W																
 <p>ACSL814 -Pershoek -Clame à presser -Eckverbinder stanzbar -Clamping corner</p> <p>X=12mm Y=95mm</p>	1	Stuk Pièce Stück Pièce	SL8311	<table border="1"> <tr><td>BR</td><td>X</td></tr> <tr><td>AN</td><td></td></tr> <tr><td>KL</td><td></td></tr> <tr><td>GS</td><td></td></tr> <tr><td>Z</td><td></td></tr> <tr><td>W</td><td></td></tr> </table>	BR	X	AN		KL		GS		Z		W	
BR	X															
AN																
KL																
GS																
Z																
W																
 <p>ACSL815 -Schroefhoek -Clame à visser -Eckverbinder schraubbar -Square coupling joint</p> <p>X=12mm Y=95mm</p>  ACVG66	1	Stuk Pièce Stück Pièce	SL8311	<table border="1"> <tr><td>BR</td><td>X</td></tr> <tr><td>AN</td><td></td></tr> <tr><td>KL</td><td></td></tr> <tr><td>GS</td><td></td></tr> <tr><td>Z</td><td></td></tr> <tr><td>W</td><td></td></tr> </table>	BR	X	AN		KL		GS		Z		W	
BR	X															
AN																
KL																
GS																
Z																
W																
 <p>ACSL816 -Pershoek -Clame à presser -Eckverbinder stanzbar -Clamping corner</p> <p>X=12mm Y=44mm</p>	1	Stuk Pièce Stück Pièce	SL815	<table border="1"> <tr><td>BR</td><td>X</td></tr> <tr><td>AN</td><td></td></tr> <tr><td>KL</td><td></td></tr> <tr><td>GS</td><td></td></tr> <tr><td>Z</td><td></td></tr> <tr><td>W</td><td></td></tr> </table>	BR	X	AN		KL		GS		Z		W	
BR	X															
AN																
KL																
GS																
Z																
W																

BR = BRUT - BRUT - ROH - BRUT
AN (X) = ANODISATIE - ANODISE - ELOXIERT - ANODISED
AN (■) = GELAKT - LAQUE - LACKIERT - LACQUERED -- RAL9006M
KL = STANDAARDKLEUREN - COULEUR STANDARD - BASIS FARBEN - BASIC COLORS
GS = GEMOFFELD SPECIAAL - LAQUE SPECIAL - SPECIALFARBE - SPECIAL COLOR
Z = ZWART - NOIR - SCHWARZ - BLACK
W = WIT - BLANC - WEISS - WHITE







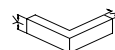

GEREEDSCHAP - OUTILLAGE
WERKZEUG - TOOL

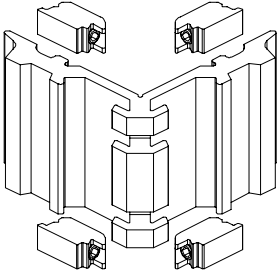

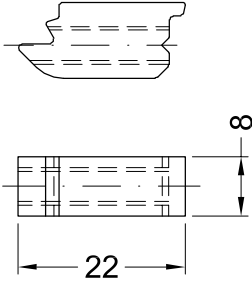

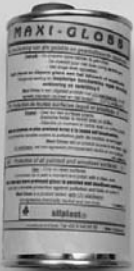

BEVESTIGING - FIXATION
BEFESTIGUNG - FIXATION

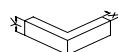

	Verp. per Emb. par Pack pr.	Einheid Unit	Toepassing Application	Kleur Couleur												
 <p>ACSL817</p> <ul style="list-style-type: none"> -Schroefhoek -Clame à visser -Eckverbinder schraubbar -Square coupling joint <p>X=12mm Y=44mm</p>  ACVG66	1	Stuk Pièce Stück Pièce	SL815	<table border="1"> <tr><td>BR</td><td>X</td></tr> <tr><td>AN</td><td></td></tr> <tr><td>KL</td><td></td></tr> <tr><td>GS</td><td></td></tr> <tr><td>Z</td><td></td></tr> <tr><td>W</td><td></td></tr> </table>	BR	X	AN		KL		GS		Z		W	
BR	X															
AN																
KL																
GS																
Z																
W																
 <p>ACMX854</p> <ul style="list-style-type: none"> -Schroefblokje 8mm -Clavet 8mm -Schraubeblock 8mm -Cleat tensioning block 8mm 	48	Stuk Pièce Stück Pièce		<table border="1"> <tr><td>BR</td><td></td></tr> <tr><td>AN</td><td></td></tr> <tr><td>KL</td><td></td></tr> <tr><td>GS</td><td></td></tr> <tr><td>Z</td><td></td></tr> <tr><td>W</td><td></td></tr> </table>	BR		AN		KL		GS		Z		W	
BR																
AN																
KL																
GS																
Z																
W																
 <p>ACMX09700</p> <ul style="list-style-type: none"> -Alu-polish -Alu-polish -Alu-polish -Alu-polish <p>750ml</p>	1	Stuk Pièce Stück Pièce		<table border="1"> <tr><td>BR</td><td></td></tr> <tr><td>AN</td><td></td></tr> <tr><td>KL</td><td></td></tr> <tr><td>GS</td><td></td></tr> <tr><td>Z</td><td></td></tr> <tr><td>W</td><td></td></tr> </table>	BR		AN		KL		GS		Z		W	
BR																
AN																
KL																
GS																
Z																
W																
 <p>ACMX09761</p> <ul style="list-style-type: none"> -Maxi-gloss -Maxi-gloss -Maxi-gloss -Maxi-gloss <p>500ml</p>	1	Stuk Pièce Stück Pièce		<table border="1"> <tr><td>BR</td><td></td></tr> <tr><td>AN</td><td></td></tr> <tr><td>KL</td><td></td></tr> <tr><td>GS</td><td></td></tr> <tr><td>Z</td><td></td></tr> <tr><td>W</td><td></td></tr> </table>	BR		AN		KL		GS		Z		W	
BR																
AN																
KL																
GS																
Z																
W																
 <p>ACMX09762</p> <ul style="list-style-type: none"> -Periodi-clean -Periodi-clean -Periodi-clean -Periodi-clean <p>500ml</p>	1	Stuk Pièce Stück Pièce		<table border="1"> <tr><td>BR</td><td></td></tr> <tr><td>AN</td><td></td></tr> <tr><td>KL</td><td></td></tr> <tr><td>GS</td><td></td></tr> <tr><td>Z</td><td></td></tr> <tr><td>W</td><td></td></tr> </table>	BR		AN		KL		GS		Z		W	
BR																
AN																
KL																
GS																
Z																
W																



		Verp. per Emb. par Pack pr. Pack pr.	Eenheid Unité Einheit Unit	Toepassing Application Anwendung Application	Kleur Couleur Farbe Color												
	ACMX09763 -Teflon spray -Teflon spray -Teflon spray -Teflon spray 400ml	1	Stuk Pièce Stück Pièce		<table border="1"> <tr><td>BR</td><td></td></tr> <tr><td>AN</td><td></td></tr> <tr><td>KL</td><td></td></tr> <tr><td>GS</td><td></td></tr> <tr><td>Z</td><td></td></tr> <tr><td>W</td><td></td></tr> </table>	BR		AN		KL		GS		Z		W	
BR																	
AN																	
KL																	
GS																	
Z																	
W																	
	ACMX09764 -Maxi-cleaner -Maxi-cleaner -Maxi-cleaner -Maxi-cleaner 500ml	1	Stuk Pièce Stück Pièce		<table border="1"> <tr><td>BR</td><td></td></tr> <tr><td>AN</td><td></td></tr> <tr><td>KL</td><td></td></tr> <tr><td>GS</td><td></td></tr> <tr><td>Z</td><td></td></tr> <tr><td>W</td><td></td></tr> </table>	BR		AN		KL		GS		Z		W	
BR																	
AN																	
KL																	
GS																	
Z																	
W																	
	ACMX09765 -Glue-cleaner -glue-cleaner -Glue-cleaner -Glue-cleaner 500ml	1	Stuk Pièce Stück Pièce		<table border="1"> <tr><td>BR</td><td></td></tr> <tr><td>AN</td><td></td></tr> <tr><td>KL</td><td></td></tr> <tr><td>GS</td><td></td></tr> <tr><td>Z</td><td></td></tr> <tr><td>W</td><td></td></tr> </table>	BR		AN		KL		GS		Z		W	
BR																	
AN																	
KL																	
GS																	
Z																	
W																	
	ACMX09766 -Surface activator -Surface activator -Surface activator -Surface activator 1l	1	Stuk Pièce Stück Pièce		<table border="1"> <tr><td>BR</td><td></td></tr> <tr><td>AN</td><td></td></tr> <tr><td>KL</td><td></td></tr> <tr><td>GS</td><td></td></tr> <tr><td>Z</td><td></td></tr> <tr><td>W</td><td></td></tr> </table>	BR		AN		KL		GS		Z		W	
BR																	
AN																	
KL																	
GS																	
Z																	
W																	
	ACMX09767 -Anti-stone opgepast voor natuursteen en metselwerk attention pour pierre de taille et maçonnerie achtung für Naturstein und Mauerwerk attention for natural stone and bricklaying 500ml	1	Stuk Pièce Stück Pièce		<table border="1"> <tr><td>BR</td><td></td></tr> <tr><td>AN</td><td></td></tr> <tr><td>KL</td><td></td></tr> <tr><td>GS</td><td></td></tr> <tr><td>Z</td><td></td></tr> <tr><td>W</td><td></td></tr> </table>	BR		AN		KL		GS		Z		W	
BR																	
AN																	
KL																	
GS																	
Z																	
W																	

BR = BRUT - BRUT - ROH - BRUT
AN (X) = ANODISATIE - ANODISE - ELOXIERT - ANODISED
AN (■) = GELAKT - LAQUE - LACKIERT - LACQUERED -- RAL9006M
KL = STANDAARDKLEUREN - COULEUR STANDARD - BASIS FARBEN - BASIC COLORS
GS = GEMOFFELD SPECIAAL - LAQUE SPECIAL - SPECIALFARBE - SPECIAL COLOR
Z = ZWART - NOIR - SCHWARZ - BLACK
W = WIT - BLANC - WEISS - WHITE



GEREEDSCHAP - OUTILLAGE
WERKZEUG - TOOL



BEVESTIGING - FIXATION
BEFESTIGUNG - FIXATION

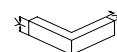

	Verp. per Emb. par Pack pr.	Einheid Unit	Toepassing Application	Kleur Couleur Farbe Color												
 <p>ACMX09770 -Rol andywrap 100mm -Rouleau andywrap 100mm -Rolle andywrap 100mm -Roll andywrap 100mm</p>	150	m		<table border="1"> <tr><td>BR</td><td></td></tr> <tr><td>AN</td><td></td></tr> <tr><td>KL</td><td></td></tr> <tr><td>GS</td><td></td></tr> <tr><td>Z</td><td></td></tr> <tr><td>W</td><td></td></tr> </table>	BR		AN		KL		GS		Z		W	
BR																
AN																
KL																
GS																
Z																
W																
 <p>ACMX09775 -Houder andywrap -Manche andywrap -Halter andywrap -Grip andywrap</p>	1	Stuk Pièce Stück Pièce		<table border="1"> <tr><td>BR</td><td></td></tr> <tr><td>AN</td><td></td></tr> <tr><td>KL</td><td></td></tr> <tr><td>GS</td><td></td></tr> <tr><td>Z</td><td></td></tr> <tr><td>W</td><td></td></tr> </table>	BR		AN		KL		GS		Z		W	
BR																
AN																
KL																
GS																
Z																
W																
 <p>ACMX09801 -Beschermtape 50mm (500m) -Tape de protection 50mm (500m) -Schutz Klebeband 50mm (500m) -Protective tape 50mm (500m)</p>	1	Stuk Pièce Stück Pièce		<table border="1"> <tr><td>BR</td><td></td></tr> <tr><td>AN</td><td></td></tr> <tr><td>KL</td><td></td></tr> <tr><td>GS</td><td></td></tr> <tr><td>Z</td><td></td></tr> <tr><td>W</td><td></td></tr> </table>	BR		AN		KL		GS		Z		W	
BR																
AN																
KL																
GS																
Z																
W																
 <p>ACMX09802 -Beschermtape 70mm (500m) -Tape de protection 70mm (500m) -Schutz Klebeband 70mm (500m) -Protective tape 70mm (500m)</p>	1	Stuk Pièce Stück Pièce		<table border="1"> <tr><td>BR</td><td></td></tr> <tr><td>AN</td><td></td></tr> <tr><td>KL</td><td></td></tr> <tr><td>GS</td><td></td></tr> <tr><td>Z</td><td></td></tr> <tr><td>W</td><td></td></tr> </table>	BR		AN		KL		GS		Z		W	
BR																
AN																
KL																
GS																
Z																
W																
 <p>ACMX09803 -Beschermtape 100mm (500m) -Tape de protection 100mm (500m) -Schutz Klebeband 100mm (500m) -Protective tape 100mm (500m)</p>	1	Stuk Pièce Stück Pièce		<table border="1"> <tr><td>BR</td><td></td></tr> <tr><td>AN</td><td></td></tr> <tr><td>KL</td><td></td></tr> <tr><td>GS</td><td></td></tr> <tr><td>Z</td><td></td></tr> <tr><td>W</td><td></td></tr> </table>	BR		AN		KL		GS		Z		W	
BR																
AN																
KL																
GS																
Z																
W																

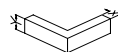

		Verp. per Emb. par Pack pr. Pack pr.	Eenheid Unité Einheit Unit	Toepassing Application Anwendung Application	Kleur Couleur Farbe Color												
	ACMX09804 -Beschermtape 35mm (500m) -Tape de protection 35mm (500m) -Schutz Klebeband 35mm (500m) -Protective tape 35mm (500m)	1	Stuk Pièce Stück Pièce		<table border="1"> <tr><td>BR</td><td></td></tr> <tr><td>AN</td><td></td></tr> <tr><td>KL</td><td></td></tr> <tr><td>GS</td><td></td></tr> <tr><td>Z</td><td></td></tr> <tr><td>W</td><td></td></tr> </table>	BR		AN		KL		GS		Z		W	
BR																	
AN																	
KL																	
GS																	
Z																	
W																	
	ACMX09830 -Kleefstof voor EPDM-rubbers -Colle pour EPDM-caoutchouc -Dichtmasse + Klebestoff EPDM-Gummi -Gum for EPDM-rubber	1	Stuk Pièce Stück Pièce		<table border="1"> <tr><td>BR</td><td></td></tr> <tr><td>AN</td><td></td></tr> <tr><td>KL</td><td></td></tr> <tr><td>GS</td><td></td></tr> <tr><td>Z</td><td></td></tr> <tr><td>W</td><td></td></tr> </table>	BR		AN		KL		GS		Z		W	
BR																	
AN																	
KL																	
GS																	
Z																	
W																	
	ACSIL04 -Afdichtingslijmkit voor versteknaden -Joint d'étanchéité pour onglets -Leim für abdichtung -Sealingglue	1	Stuk Pièce Stück Pièce		<table border="1"> <tr><td>BR</td><td></td></tr> <tr><td>AN</td><td></td></tr> <tr><td>KL</td><td></td></tr> <tr><td>GS</td><td></td></tr> <tr><td>Z</td><td>X</td></tr> <tr><td>W</td><td>X</td></tr> </table>	BR		AN		KL		GS		Z	X	W	X
BR																	
AN																	
KL																	
GS																	
Z	X																
W	X																
	ACSIL08 -Siliconenpomp -Pistolet doseur pour les tubes silicones -Handkartuschenpistole für die verarbeitung von silikone und leime -Silicone gun	1	Stuk Pièce Stück Pièce		<table border="1"> <tr><td>BR</td><td></td></tr> <tr><td>AN</td><td></td></tr> <tr><td>KL</td><td></td></tr> <tr><td>GS</td><td></td></tr> <tr><td>Z</td><td></td></tr> <tr><td>W</td><td></td></tr> </table>	BR		AN		KL		GS		Z		W	
BR																	
AN																	
KL																	
GS																	
Z																	
W																	
	ACSIL013 -Lijm voor verstekhoek -Colle pour onglet -Kleber für gehrung -Glue for mitre	1	Stuk Pièce Stück Pièce		<table border="1"> <tr><td>BR</td><td></td></tr> <tr><td>AN</td><td></td></tr> <tr><td>KL</td><td></td></tr> <tr><td>GS</td><td></td></tr> <tr><td>Z</td><td></td></tr> <tr><td>W</td><td></td></tr> </table>	BR		AN		KL		GS		Z		W	
BR																	
AN																	
KL																	
GS																	
Z																	
W																	

BR = BRUT - BRUT - ROH - BRUT
 AN (X) = ANODISATIE - ANODISE - ELOXIERT - ANODISED
 AN (■) = GELAKT - LAQUE - LACKIERT - LACQUERED -- RAL9006M
 KL = STANDAARDKLEUREN - COULEUR STANDARD - BASIS FARBEN - BASIC COLORS
 GS = GEMOFFELD SPECIAAL - LAQUE SPECIAL - SPECIALFARBE - SPECIAL COLOR
 Z = ZWART - NOIR - SCHWARZ - BLACK
 W = WIT - BLANC - WEISS - WHITE



GEREEDSCHAP - OUTILLAGE
WERKZEUG - TOOL



BEVESTIGING - FIXATION
BEFESTIGUNG - FIXATION

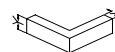

		Verp. per Emb. par Pack pr.	Einheid Unité Einheit Unit	Toepassing Application Anwendung Application	Kleur Couleur Farbe Color												
	<p>ACSIL014</p> <ul style="list-style-type: none"> -Anticorro-beschermingsproduct -Anticorro-produit de protection -Anticorro-schutzprodukt -Anticorro-protection product <p>500ml</p>	1	Stuk Pièce Stück Pièce		<table border="1"> <tr><td>BR</td><td></td></tr> <tr><td>AN</td><td></td></tr> <tr><td>KL</td><td></td></tr> <tr><td>GS</td><td></td></tr> <tr><td>Z</td><td></td></tr> <tr><td>W</td><td></td></tr> </table>	BR		AN		KL		GS		Z		W	
BR																	
AN																	
KL																	
GS																	
Z																	
W																	
	<p>ACVG42</p> <ul style="list-style-type: none"> -Borstelafdichting -Brosse -Bürstenafdichtung -Brush 	100	m	SL820 SL821 SL830 SL831 SL8120	<table border="1"> <tr><td>BR</td><td></td></tr> <tr><td>AN</td><td></td></tr> <tr><td>KL</td><td></td></tr> <tr><td>GS</td><td></td></tr> <tr><td>Z</td><td></td></tr> <tr><td>W</td><td></td></tr> </table>	BR		AN		KL		GS		Z		W	
BR																	
AN																	
KL																	
GS																	
Z																	
W																	
	<p>ACVG66</p> <ul style="list-style-type: none"> -Zeskantsleutel 3mm -Clé à six pans 3mm -Sechskantschlüssel 3mm -T-handle hexagon key 3mm 	1	Stuk Pièce Stück Pièce	ACSL813A	<table border="1"> <tr><td>BR</td><td></td></tr> <tr><td>AN</td><td></td></tr> <tr><td>KL</td><td></td></tr> <tr><td>GS</td><td></td></tr> <tr><td>Z</td><td></td></tr> <tr><td>W</td><td></td></tr> </table>	BR		AN		KL		GS		Z		W	
BR																	
AN																	
KL																	
GS																	
Z																	
W																	
	<p>ACVL060</p> <ul style="list-style-type: none"> -Sluitstuk PVC voor condensgoot -Arrêt d'eau PVC pour seuil -Dichtungsstück PVC -Nylon piece for sill member 	1	Stuk Pièce Stück Pièce	EL857	<table border="1"> <tr><td>BR</td><td></td></tr> <tr><td>AN</td><td></td></tr> <tr><td>KL</td><td></td></tr> <tr><td>GS</td><td></td></tr> <tr><td>Z</td><td>X</td></tr> <tr><td>W</td><td>X</td></tr> </table>	BR		AN		KL		GS		Z	X	W	X
BR																	
AN																	
KL																	
GS																	
Z	X																
W	X																
	<p>ACVL061</p> <ul style="list-style-type: none"> -Blindklinknagel -Rivet pop -Blindniete -Rivet 	100	Stuks Pièces Stücke Pièces	EL857	<table border="1"> <tr><td>BR</td><td></td></tr> <tr><td>AN</td><td></td></tr> <tr><td>KL</td><td></td></tr> <tr><td>GS</td><td></td></tr> <tr><td>Z</td><td></td></tr> <tr><td>W</td><td></td></tr> </table>	BR		AN		KL		GS		Z		W	
BR																	
AN																	
KL																	
GS																	
Z																	
W																	

BR = BRUT - BRUT - ROH - BRUT
 AN (X) = ANODISATIE - ANODISE - ELOXIERT - ANODISED
 AN (■) = GELAKT - LAQUE - LACKIERT - LACQUERED -- RAL9006M
 KL = STANDAARDKLEUREN - COULEUR STANDARD - BASIS FARBEN - BASIC COLORS
 GS = GEMOFFELD SPECIAAL - LAQUE SPECIAL - SPECIALFARBE - SPECIAL COLOR
 Z = ZWART - NOIR - SCHWARZ - BLACK
 W = WIT - BLANC - WEISS - WHITE







GEREEDSCHAP - OUTILLAGE
WERKZEUG - TOOL

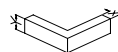

BEVESTIGING - FIXATION
BEFESTIGUNG - FIXATION

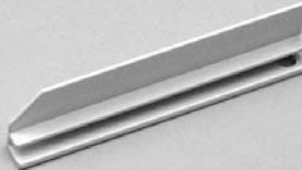

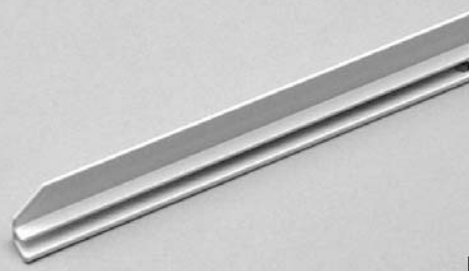
		Verp. per Emb. par Pack pr. Pack pr.	Eenheid Unité Einheit Unit	Toepassing Application Anwendung Application	Kleur Couleur Farbe Color												
 L	ACVL479 L/R -Eindstukken -Pièces latérales -Abdichtung -Sealing sill member	1	Stuk Pièce Stück Pièce	VL479	<table border="1"> <tr><td>BR</td><td>X</td></tr> <tr><td>AN</td><td>X</td></tr> <tr><td>KL</td><td>X</td></tr> <tr><td>GS</td><td>X</td></tr> <tr><td>Z</td><td></td></tr> <tr><td>W</td><td></td></tr> </table>	BR	X	AN	X	KL	X	GS	X	Z		W	
BR	X																
AN	X																
KL	X																
GS	X																
Z																	
W																	
 L	ACVL480 L/R -Eindstukken -Pièces latérales -Abdichtung -Sealing sill member	1	Stuk Pièce Stück Pièce	VL480	<table border="1"> <tr><td>BR</td><td>X</td></tr> <tr><td>AN</td><td>X</td></tr> <tr><td>KL</td><td>X</td></tr> <tr><td>GS</td><td>X</td></tr> <tr><td>Z</td><td></td></tr> <tr><td>W</td><td></td></tr> </table>	BR	X	AN	X	KL	X	GS	X	Z		W	
BR	X																
AN	X																
KL	X																
GS	X																
Z																	
W																	
 L	ACVL481 L/R -Eindstukken -Pièces latérales -Abdichtung -Sealing sill member	1	Stuk Pièce Stück Pièce	VL481	<table border="1"> <tr><td>BR</td><td>X</td></tr> <tr><td>AN</td><td>X</td></tr> <tr><td>KL</td><td>X</td></tr> <tr><td>GS</td><td>X</td></tr> <tr><td>Z</td><td></td></tr> <tr><td>W</td><td></td></tr> </table>	BR	X	AN	X	KL	X	GS	X	Z		W	
BR	X																
AN	X																
KL	X																
GS	X																
Z																	
W																	
 L	ACVL482 L/R -Eindstukken -Pièces latérales -Abdichtung -Sealing sill member	1	Stuk Pièce Stück Pièce	VL482	<table border="1"> <tr><td>BR</td><td>X</td></tr> <tr><td>AN</td><td>X</td></tr> <tr><td>KL</td><td>X</td></tr> <tr><td>GS</td><td>X</td></tr> <tr><td>Z</td><td></td></tr> <tr><td>W</td><td></td></tr> </table>	BR	X	AN	X	KL	X	GS	X	Z		W	
BR	X																
AN	X																
KL	X																
GS	X																
Z																	
W																	
 L	ACVL483 L/R -Eindstukken -Pièces latérales -Abdichtung -Sealing sill member	1	Stuk Pièce Stück Pièce	VL483	<table border="1"> <tr><td>BR</td><td>X</td></tr> <tr><td>AN</td><td>X</td></tr> <tr><td>KL</td><td>X</td></tr> <tr><td>GS</td><td>X</td></tr> <tr><td>Z</td><td></td></tr> <tr><td>W</td><td></td></tr> </table>	BR	X	AN	X	KL	X	GS	X	Z		W	
BR	X																
AN	X																
KL	X																
GS	X																
Z																	
W																	

BR = BRUT - BRUT - ROH - BRUT
AN (X) = ANODISATIE - ANODISE - ELOXIERT - ANODISED
AN (■) = GELAKT - LAQUE - LACKIERT - LACQUERED -- RAL9006M
KL = STANDAARDKLEUREN - COULEUR STANDARD - BASIS FARBEN - BASIC COLORS
GS = GEMOFFELD SPECIAAL - LAQUE SPECIAL - SPECIALFARBE - SPECIAL COLOR
Z = ZWART - NOIR - SCHWARZ - BLACK
W = WIT - BLANC - WEISS - WHITE



GEREEDSCHAP - OUTILLAGE
WERKZEUG - TOOL



BEVESTIGING - FIXATION
BEFESTIGUNG - FIXATION

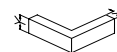

	Verp. per Emb. par Pack pr.	Einheid Unité Einheit Unit	Toepassing Application Anwendung Application	Kleur Couleur Farbe Color	
 <p>ACVL484 L/R -Eindstukken -Pièces latérales -Abdichtung -Sealing sill member</p>	1	Stuk Pièce Stück Piece	VL484	BR	X
				AN	X
				KL	X
				GS	X
				Z	
				W	

BR = BRUT - BRUT - ROH - BRUT
 AN (X) = ANODISATIE - ANODISE - ELOXIERT - ANODISED
 AN (■) = GELAKT - LAQUE - LACKIERT - LACQUERED -- RAL9006M
 KL = STANDAARDKLEUREN - COULEUR STANDARD - BASIS FARBEN - BASIC COLORS
 GS = GEMOFFELD SPECIAAL - LAQUE SPECIAL - SPECIALFARBE - SPECIAL COLOR
 Z = ZWART - NOIR - SCHWARZ - BLACK
 W = WIT - BLANC - WEISS - WHITE



GEREEDSCHAP - OUTILLAGE
WERKZEUG - TOOL



BEVESTIGING - FIXATION
BEFESTIGUNG - FIXATION

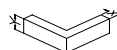

SCHUIFRAMEN
FENETRES COULISSANTES
SCHIEBEFENSTER
SLIDING WINDOWS

DOORSNEDE - COUPE - SCHNITT - SECTION

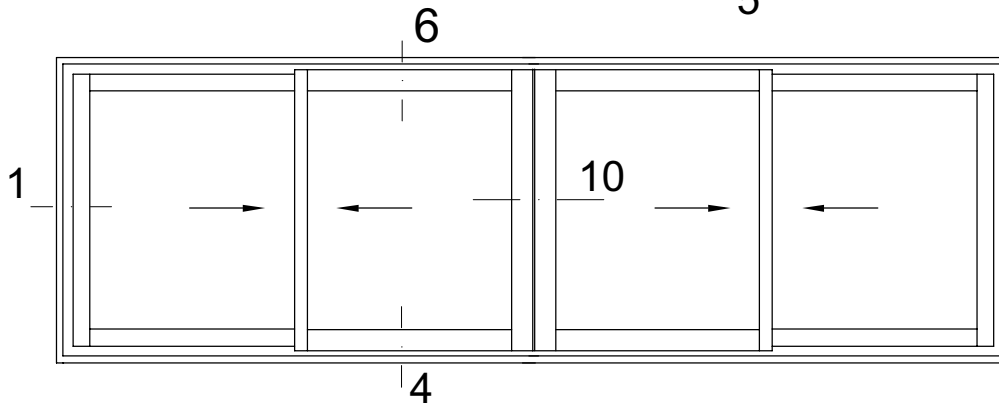
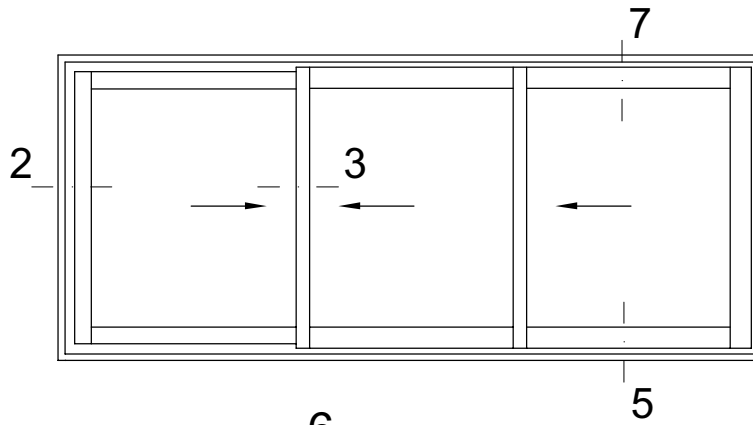
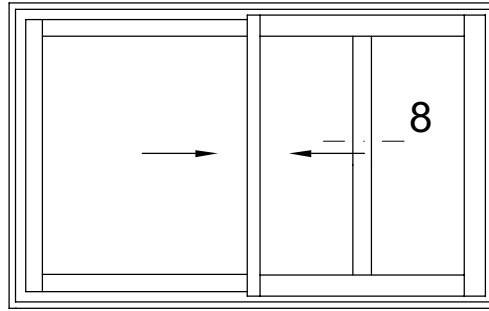
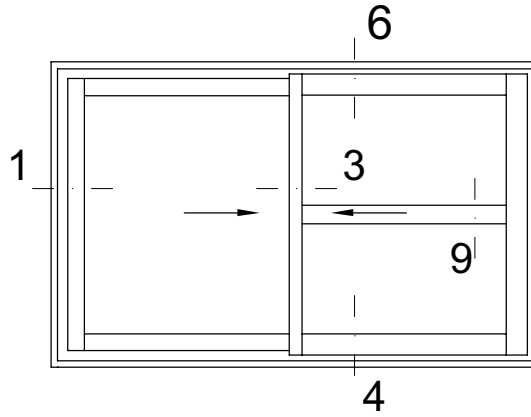

Overz

1A

DOORSNEDE - COUPE - SCHNITT - SECTION

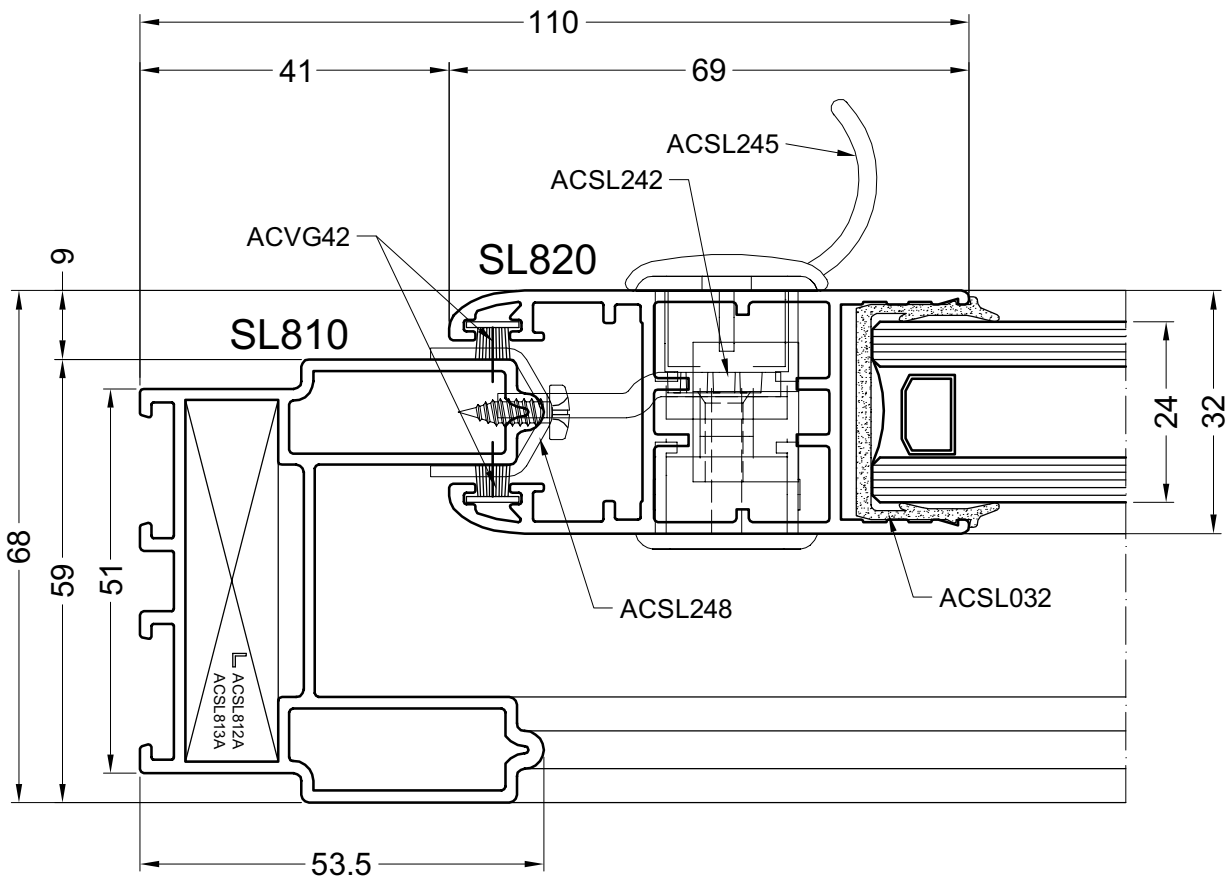
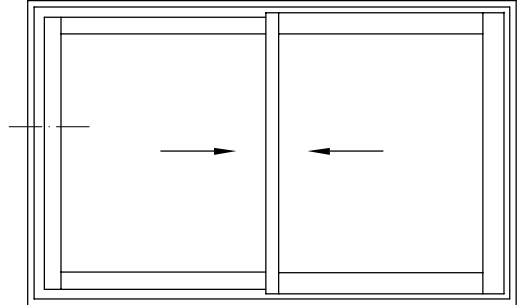

door1a

1B

DOORSNEDE - COUPE - SCHNITT - SECTION

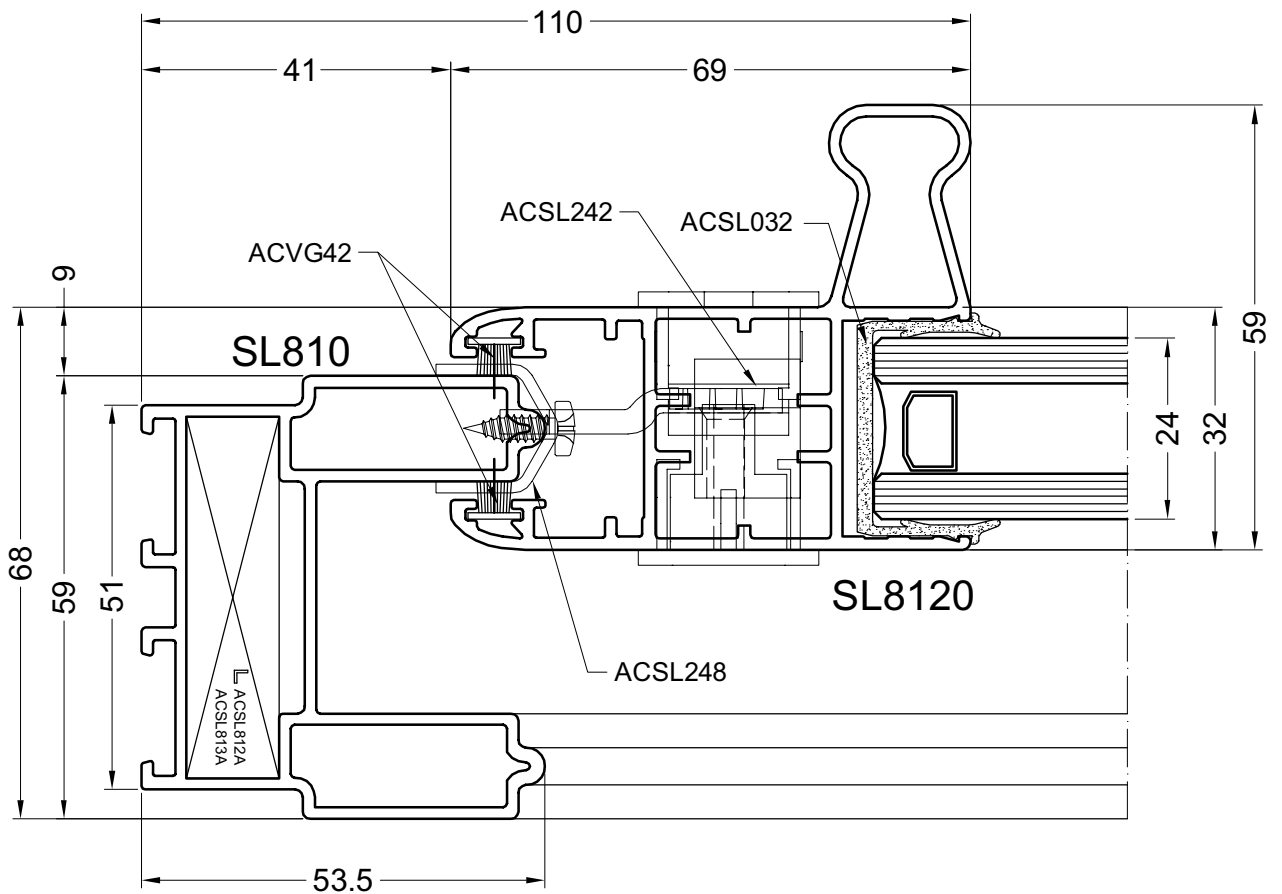
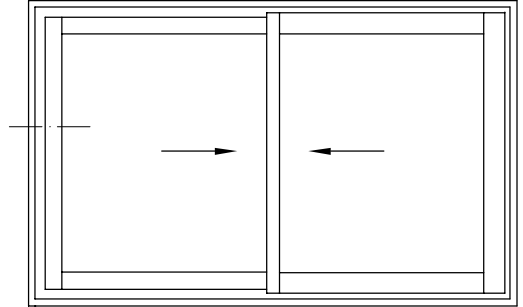

door1b

1C

DOORSNEDE - COUPE - SCHNITT - SECTION

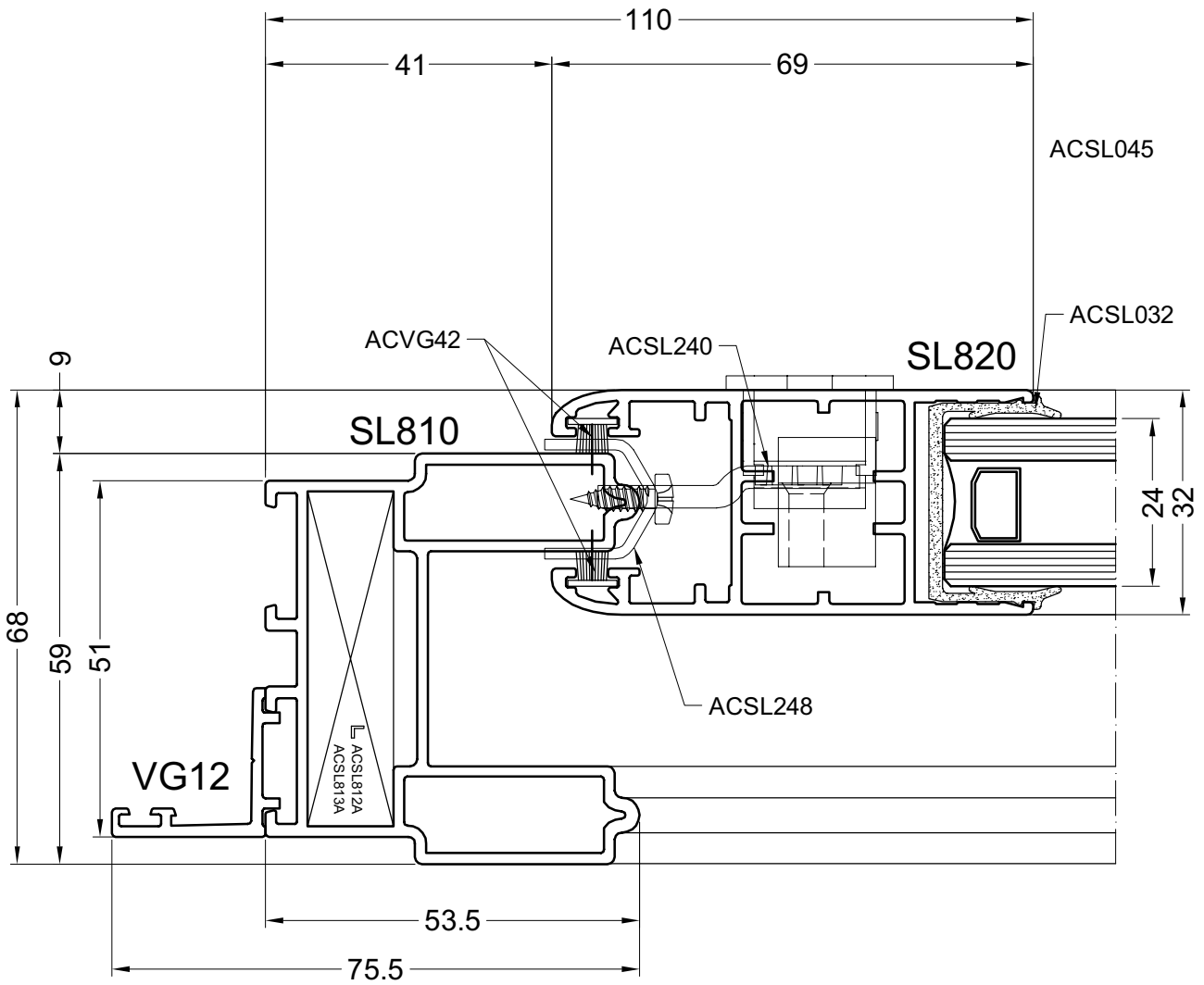
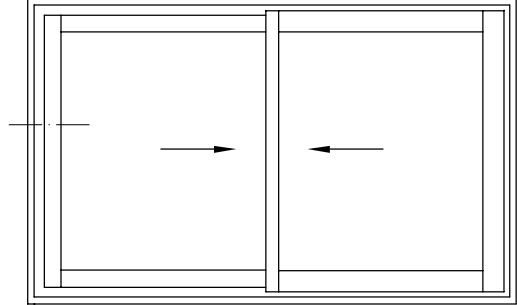

door1c

1D

DOORSNEDE - COUPE - SCHNITT - SECTION

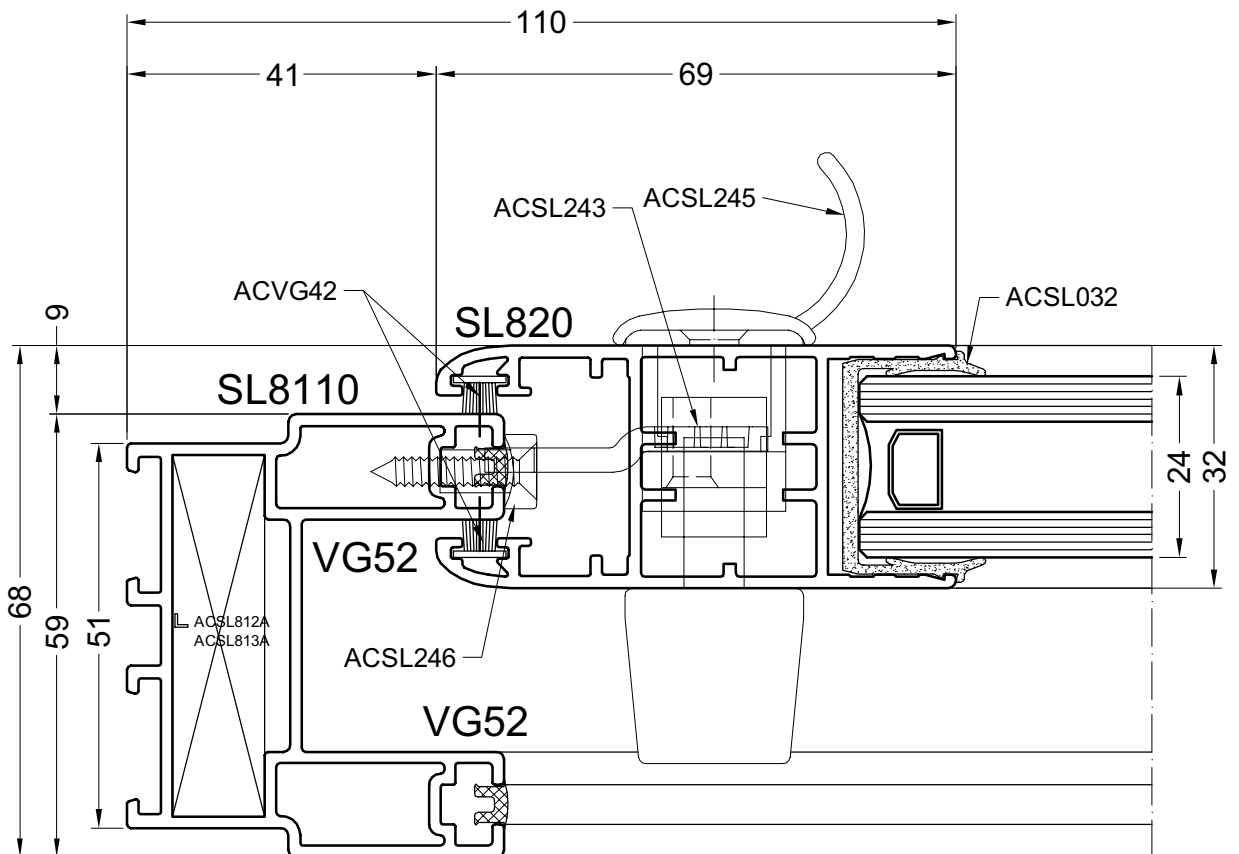
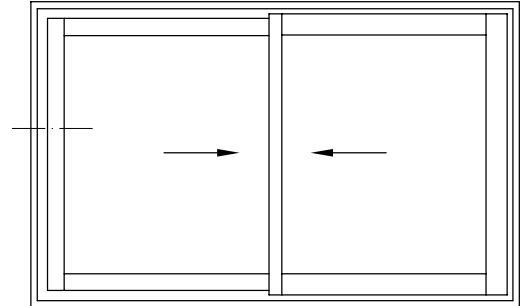

door1d

2

DOORSNEDE - COUPE - SCHNITT - SECTION

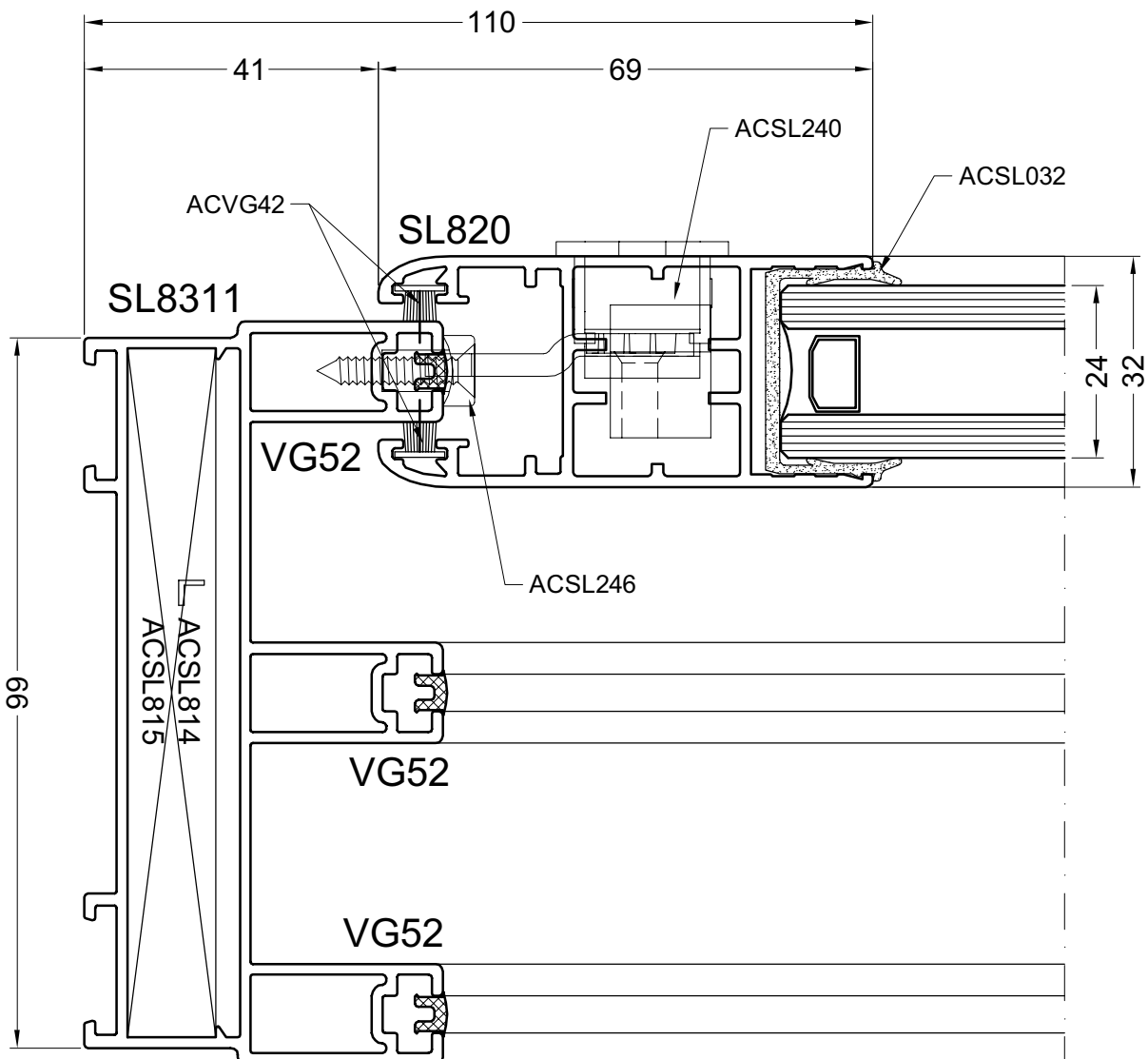
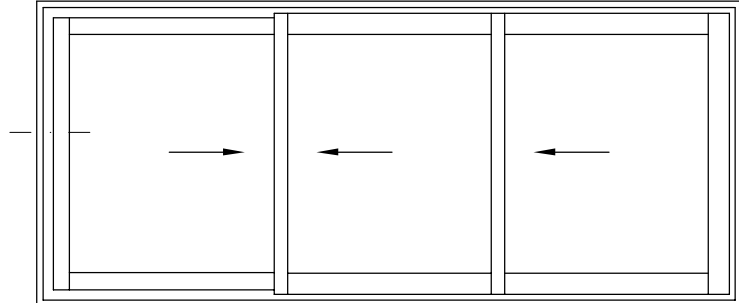

door2

3A

DOORSNEDE - COUPE - SCHNITT - SECTION

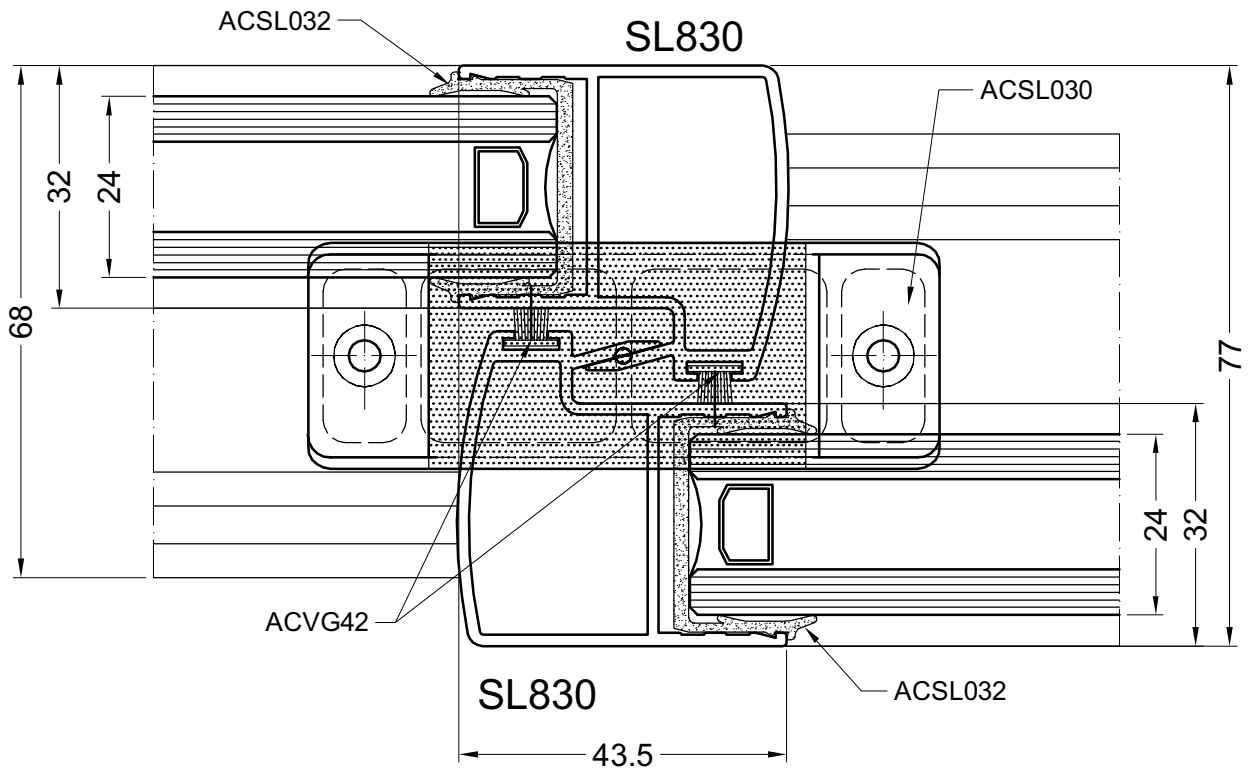
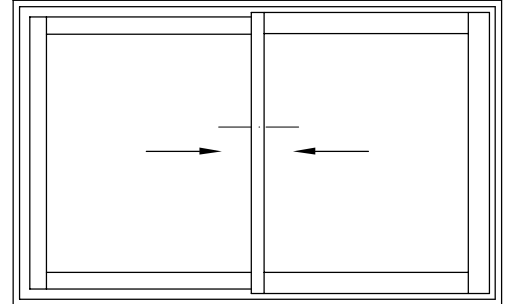

door3a

3B

DOORSNEDE - COUPE - SCHNITT - SECTION

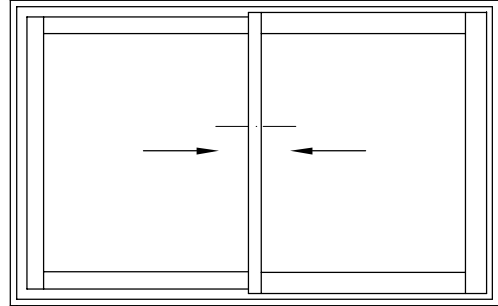

SL831

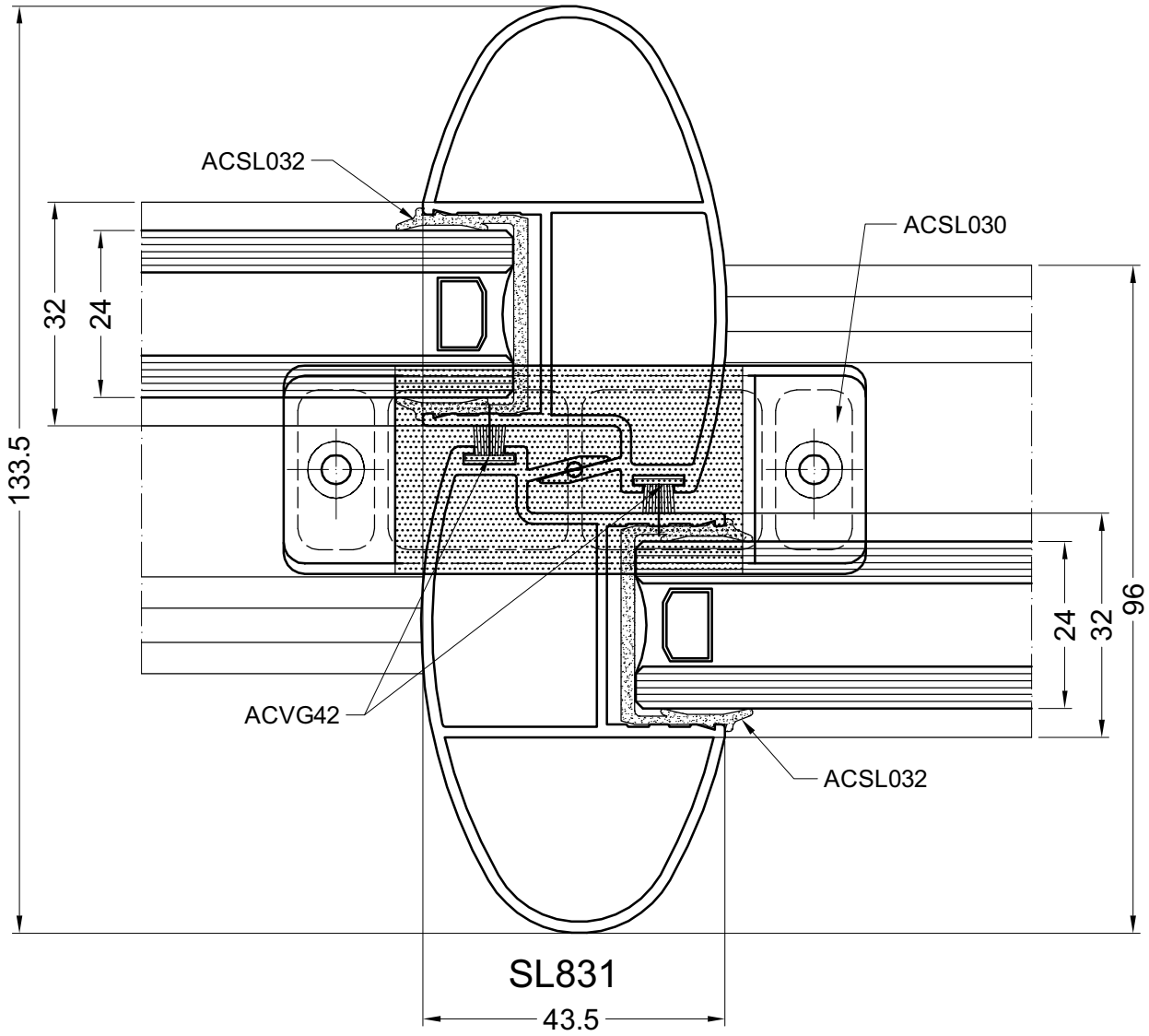

door3b

4A

DOORSNEDE - COUPE - SCHNITT - SECTION

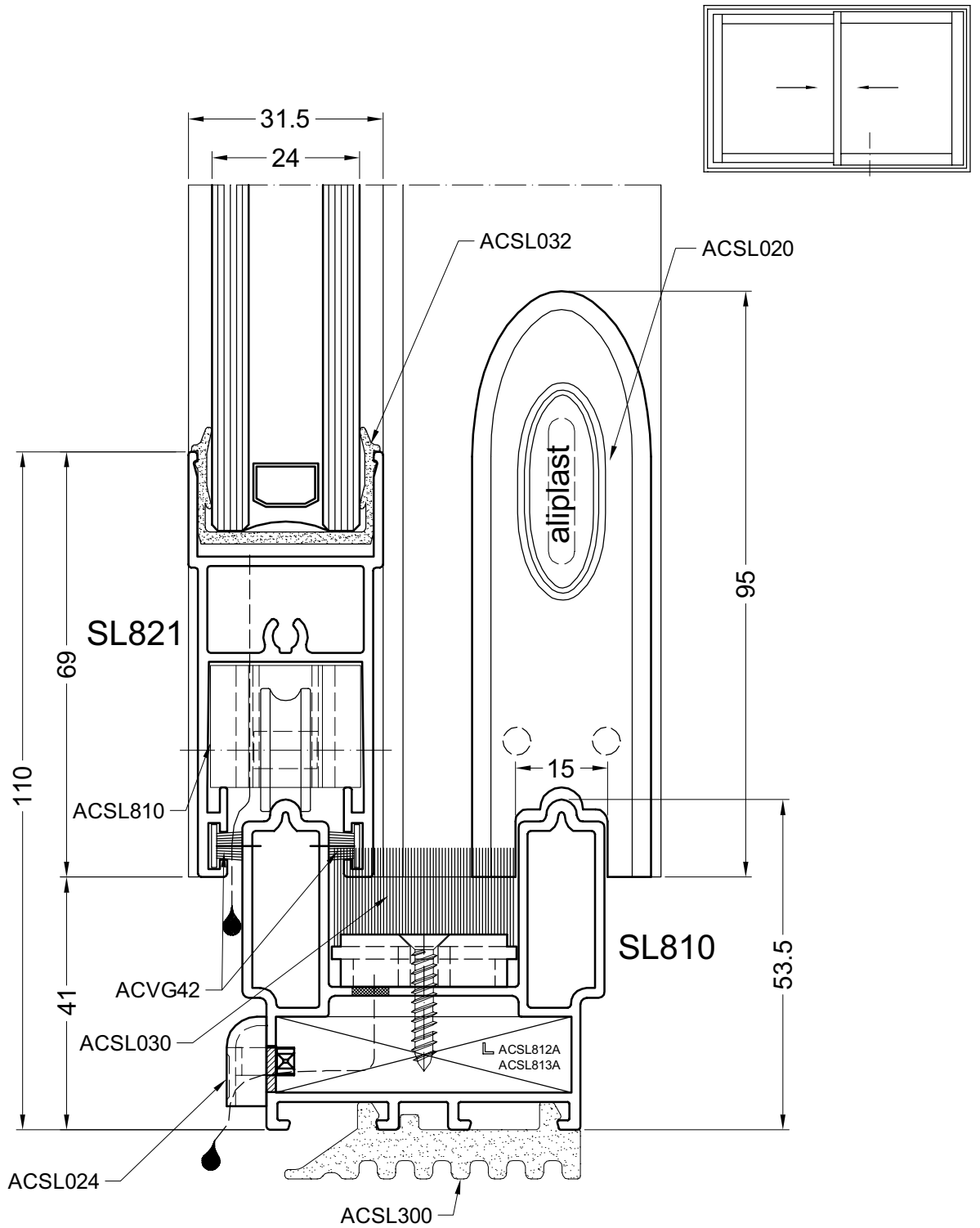

door4a

4B

DOORSNEDE - COUPE - SCHNITT - SECTION

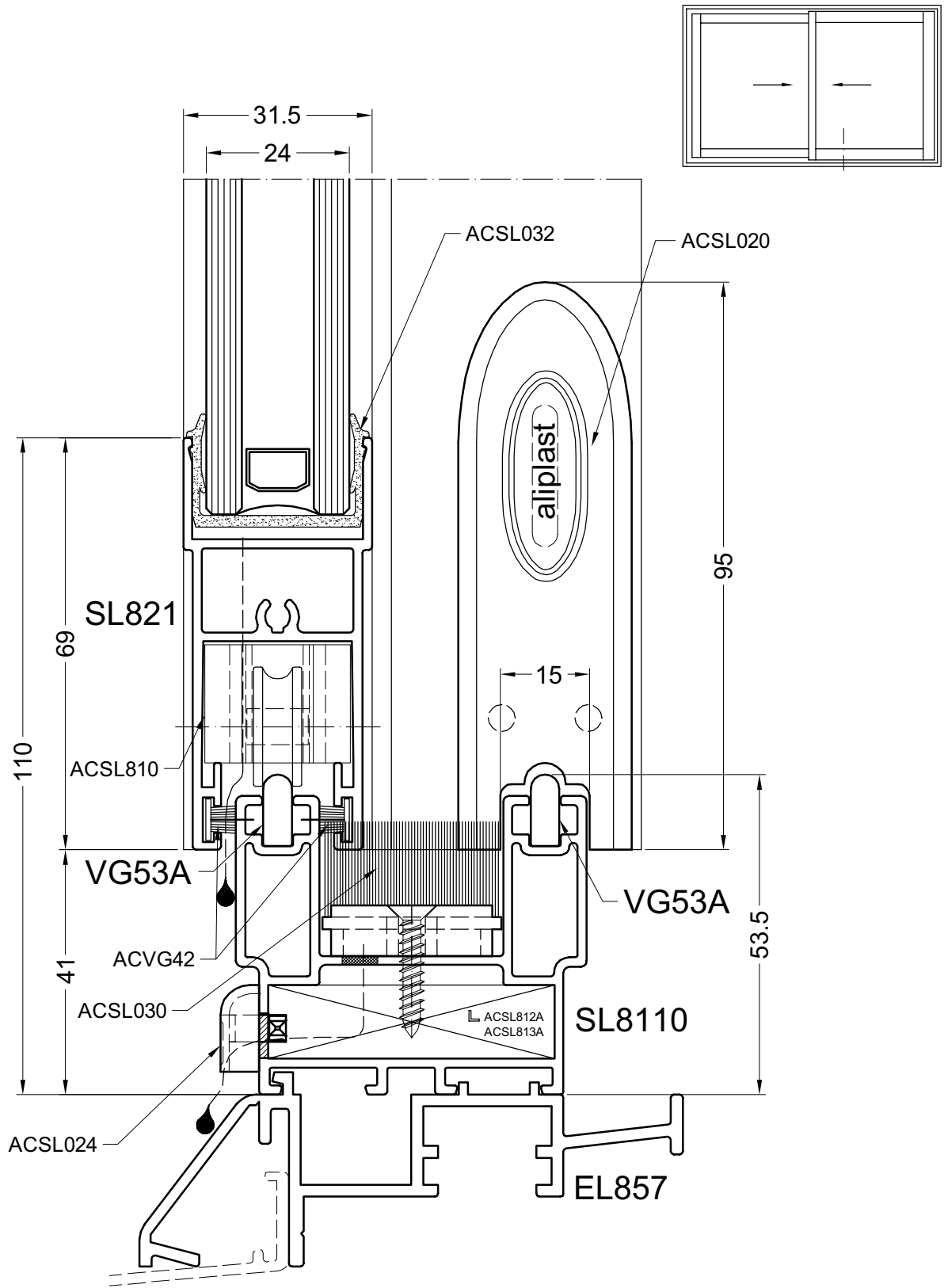

door4b

5

DOORSNEDE - COUPE - SCHNITT - SECTION

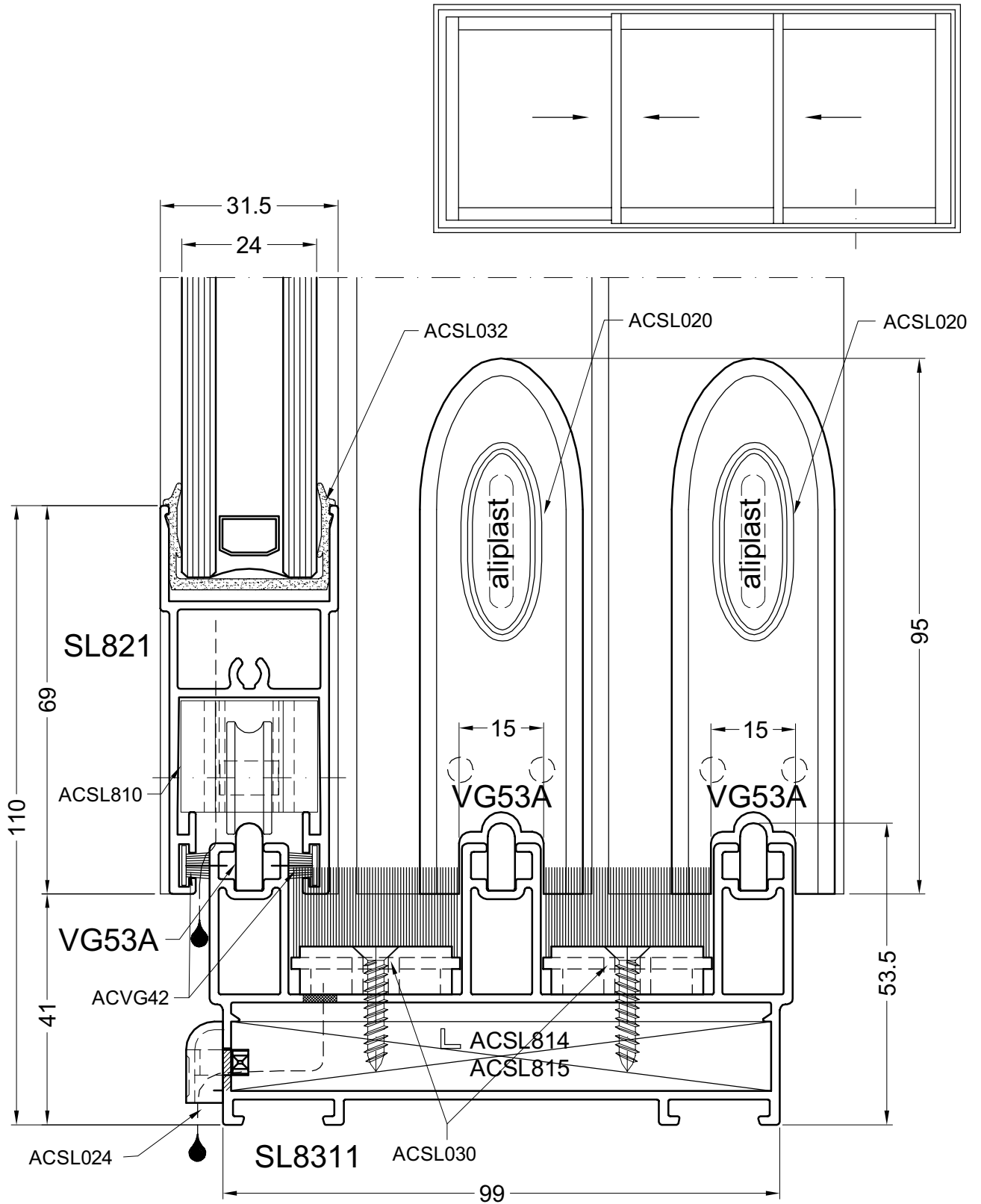

door5

6A

DOORSNEDE - COUPE - SCHNITT - SECTION

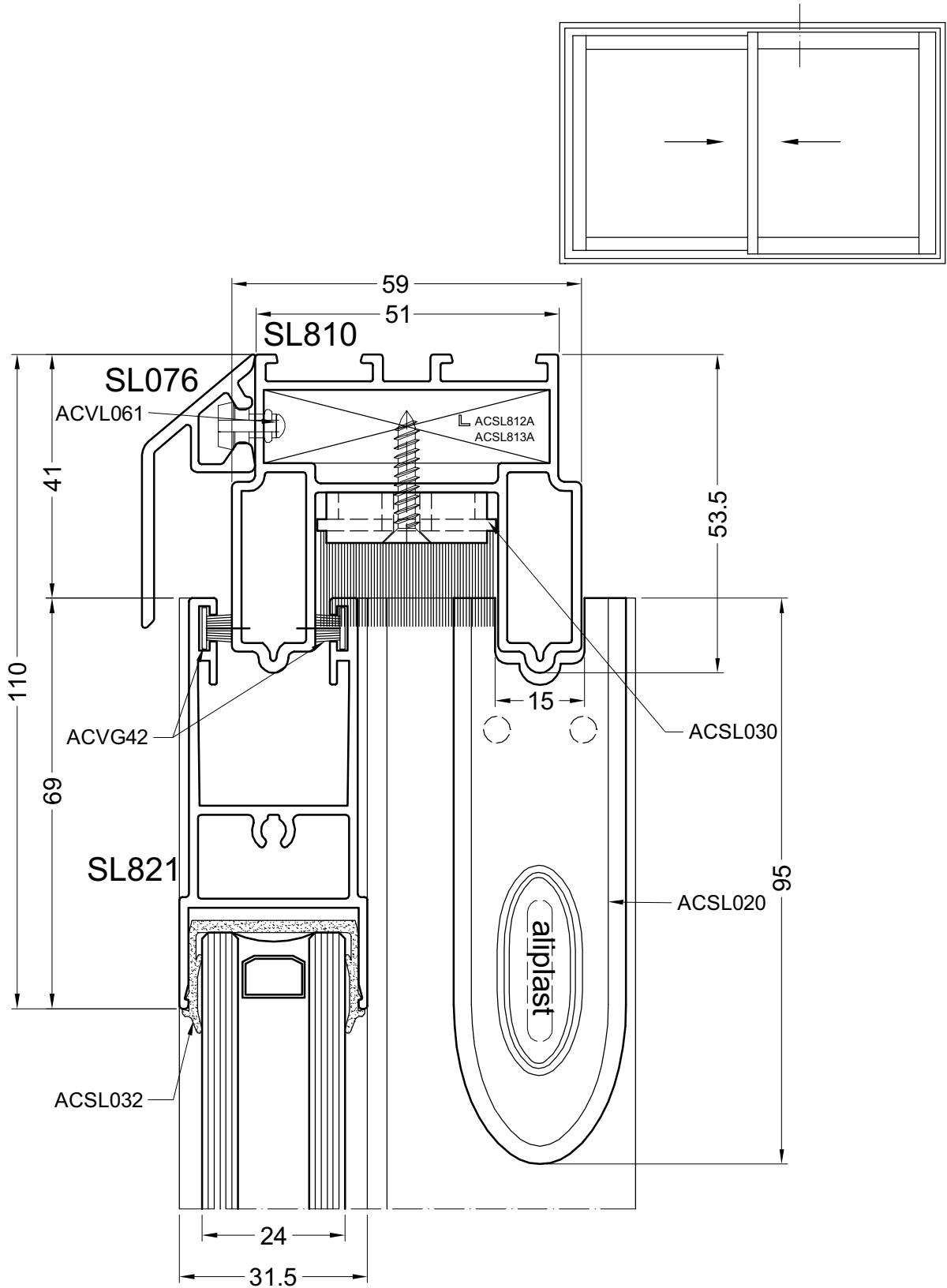

door6a

6B

DOORSNEDE - COUPE - SCHNITT - SECTION

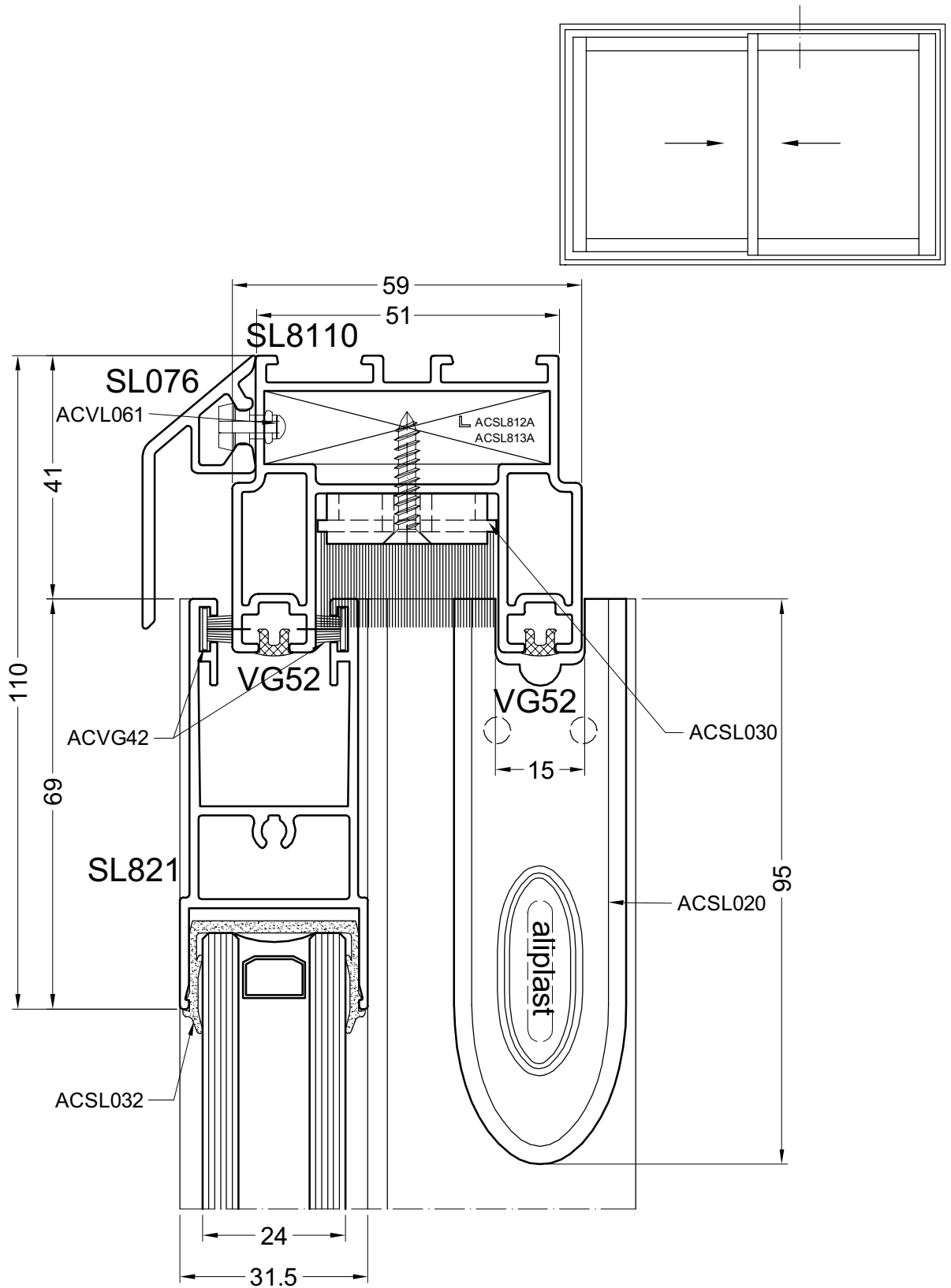

door6b

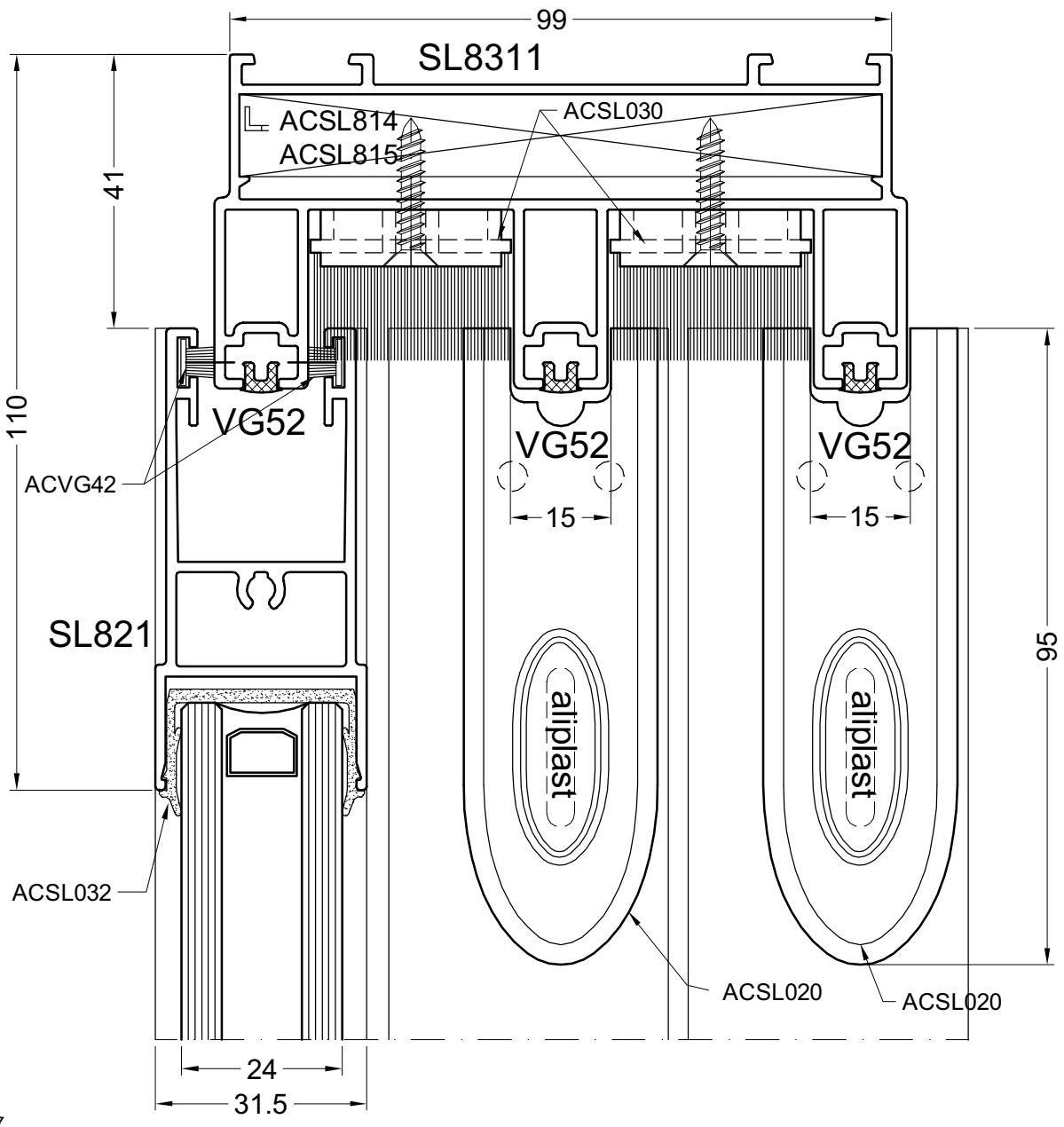
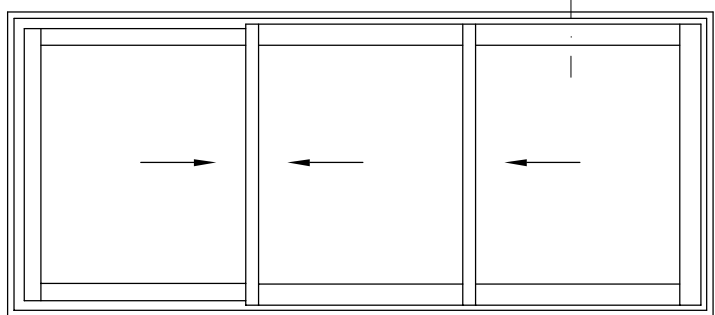

door7

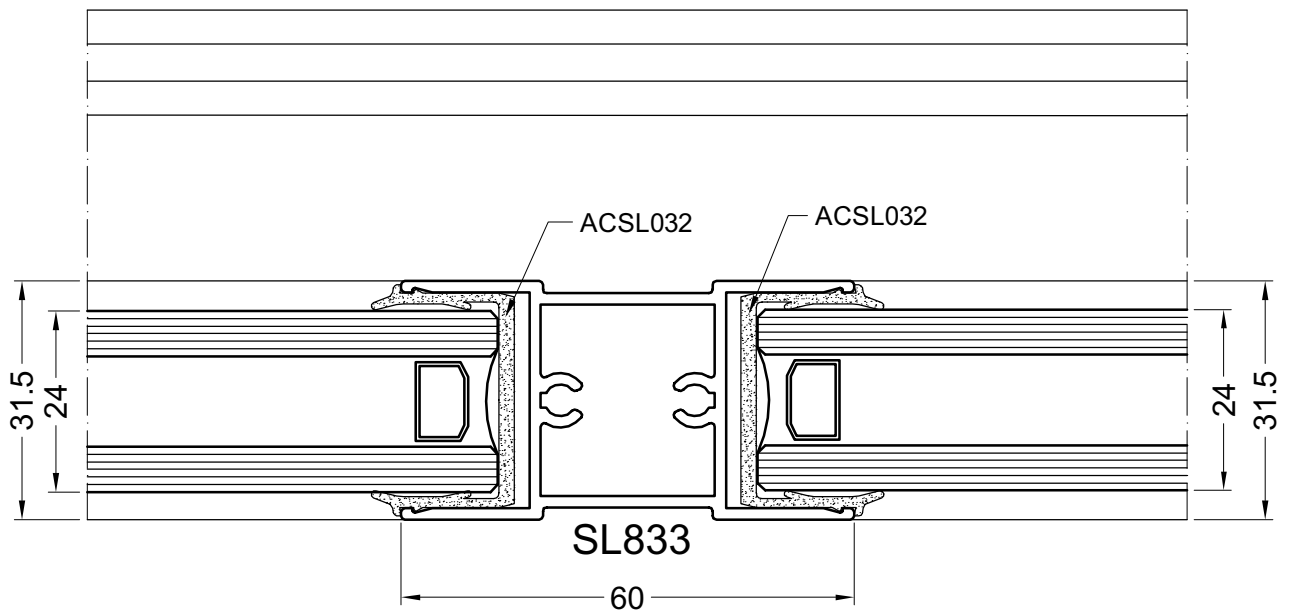
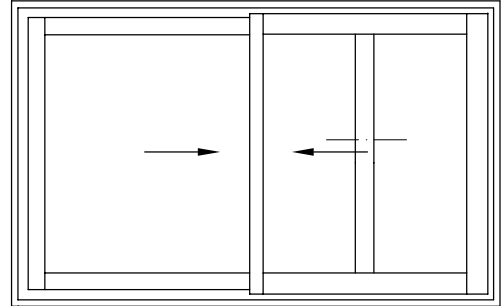

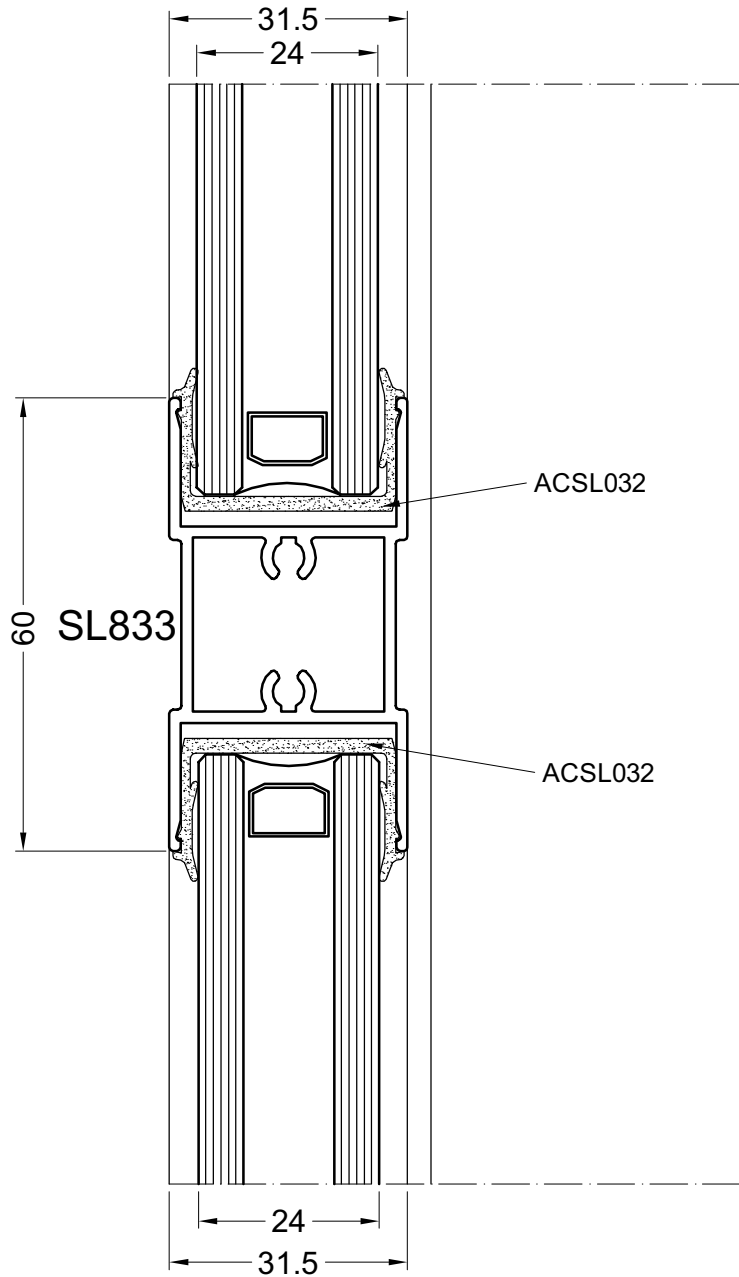
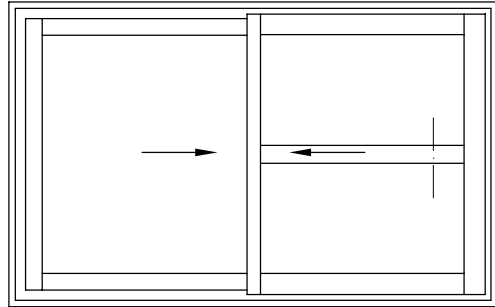

door9

10

DOORSNEDE - COUPE - SCHNITT - SECTION

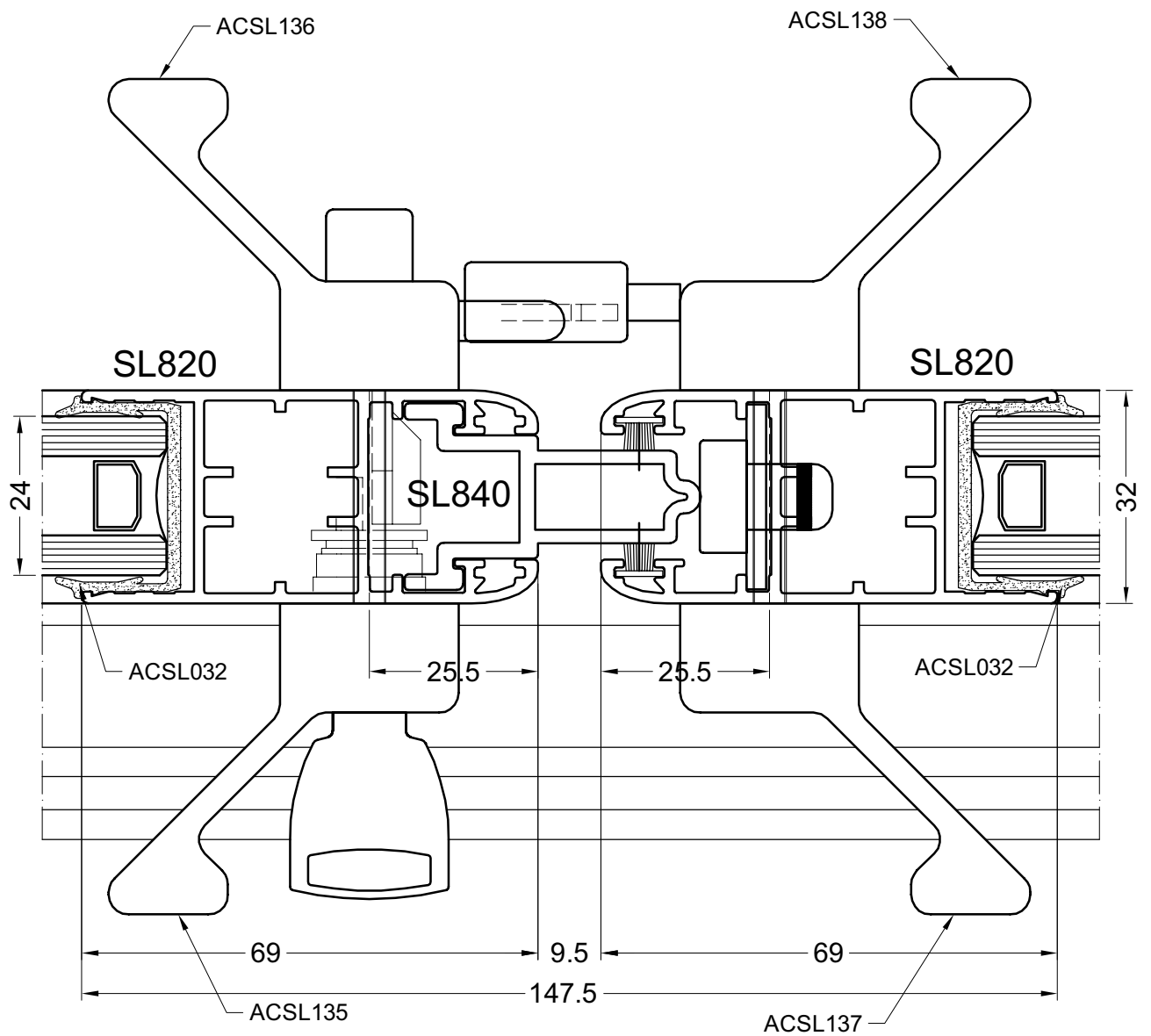
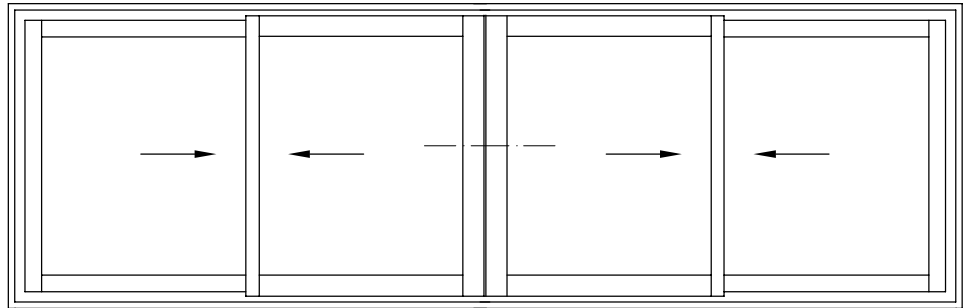

door10

DOORSNEDE - COUPE - SCHNITT - SECTION

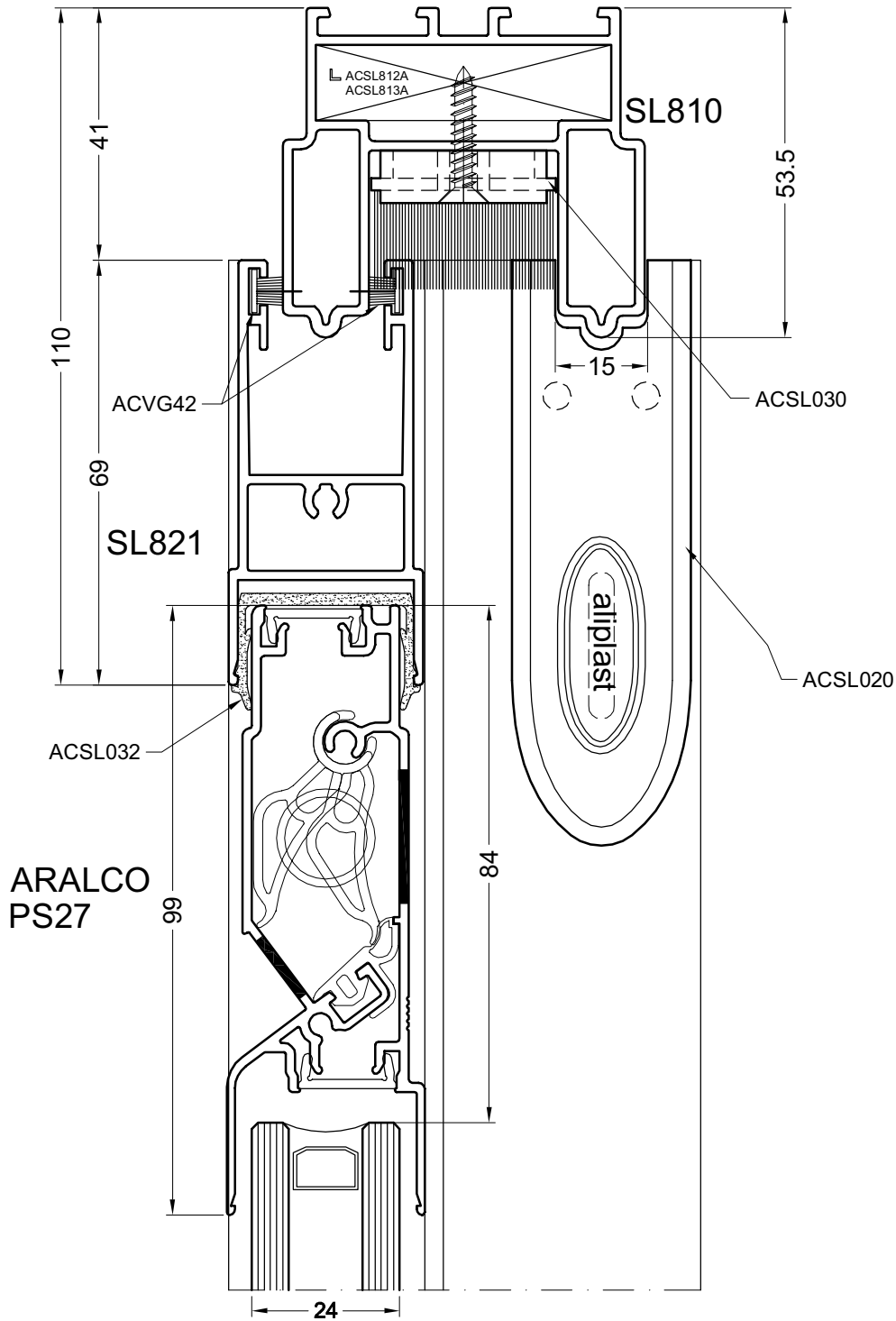

rooster1

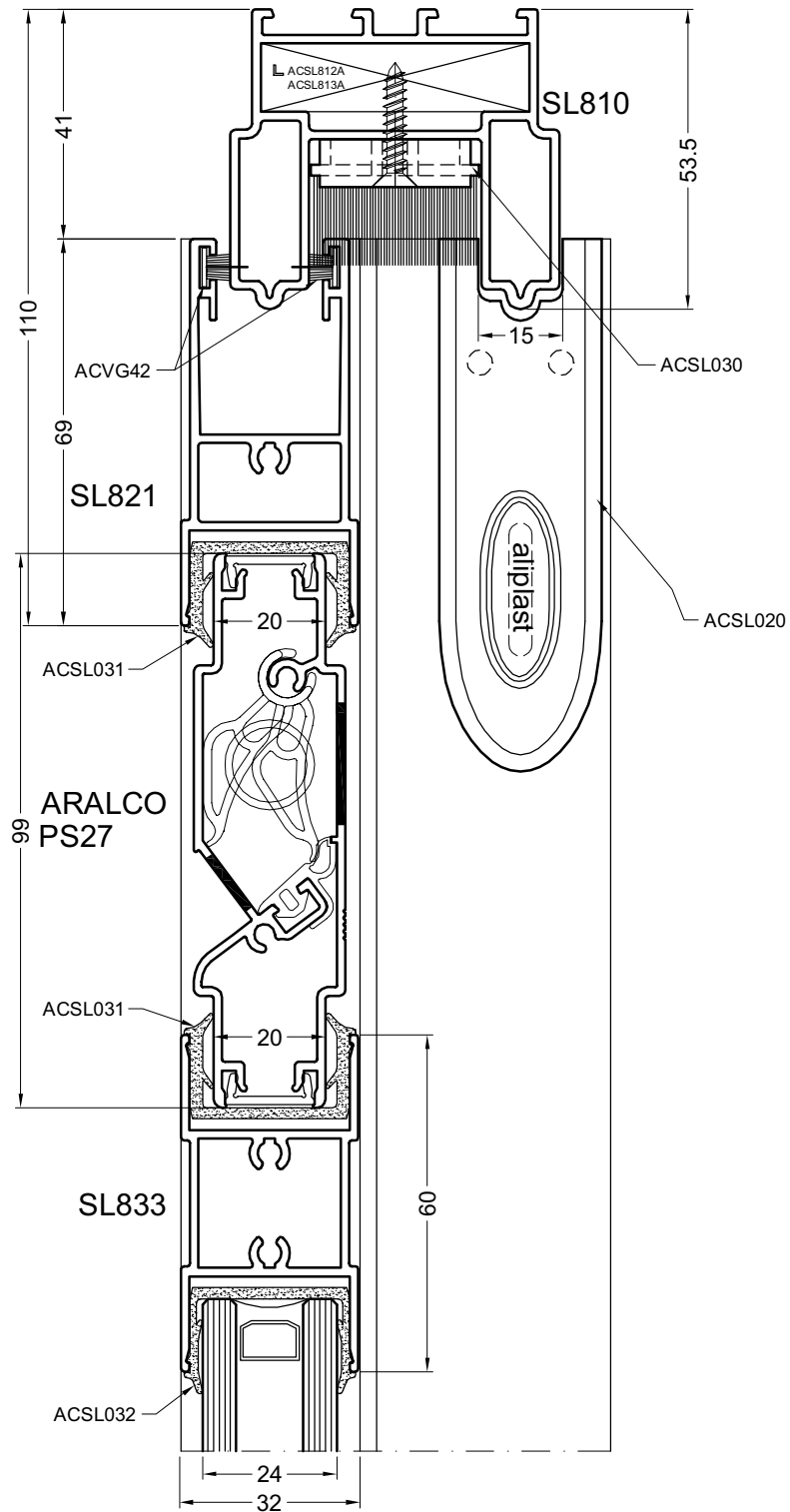

rooster2

SCHUIFDEUREN
PORTES COIULISSANTES
SCHIEBETUREN
SLIDING DOORS

DOORSNEDE - COUPE - SCHNITT - SECTION

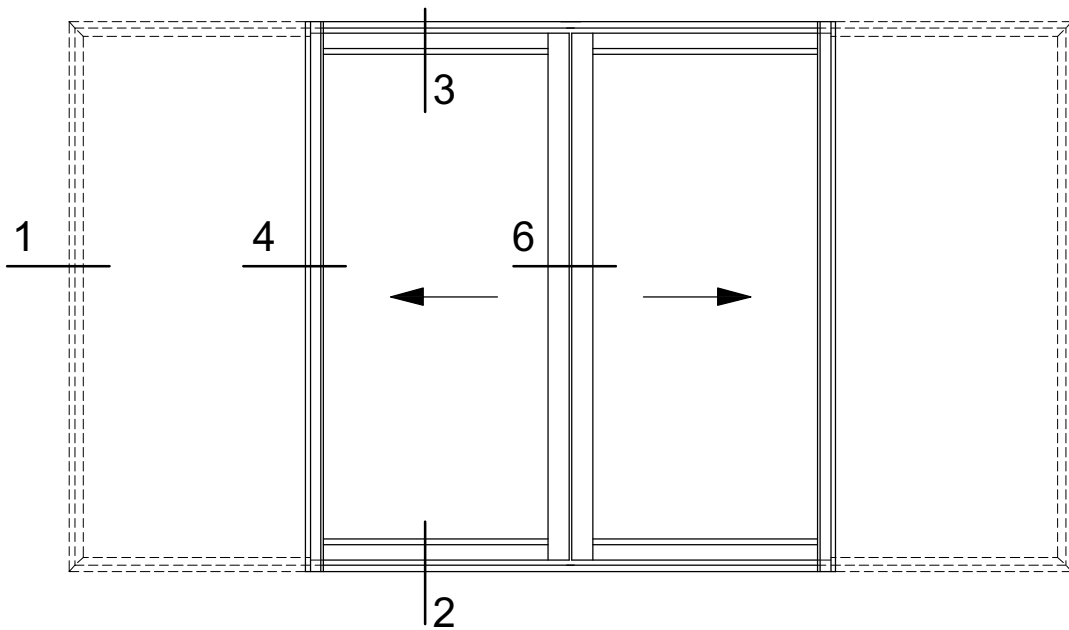
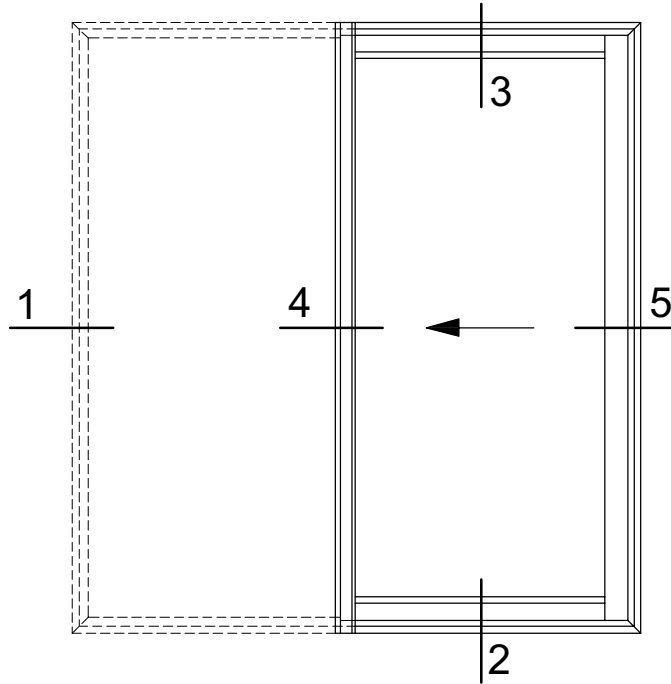

over2

1

DOORSNEDE - COUPE - SCHNITT - SECTION

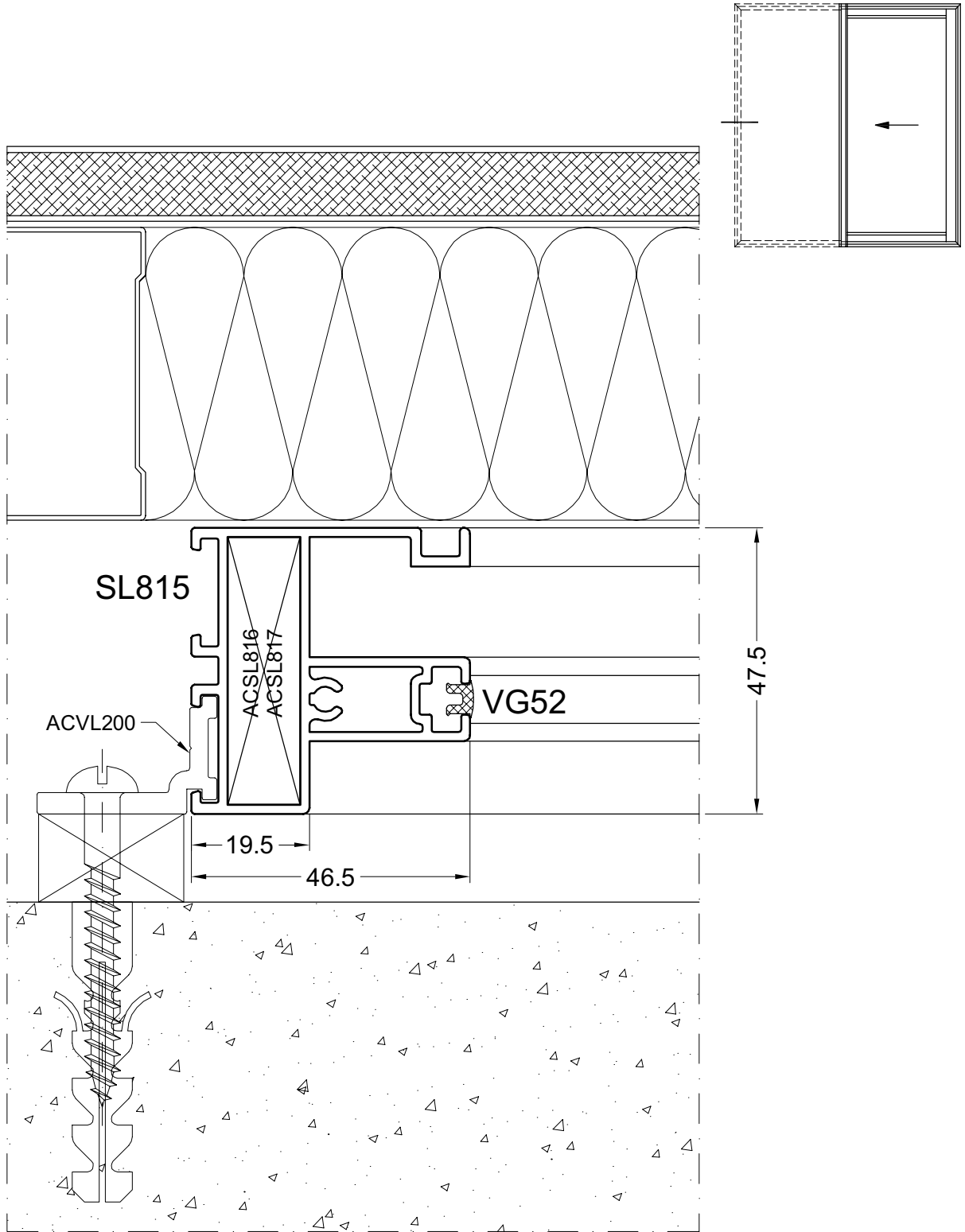

door11

2A

DOORSNEDE - COUPE - SCHNITT - SECTION

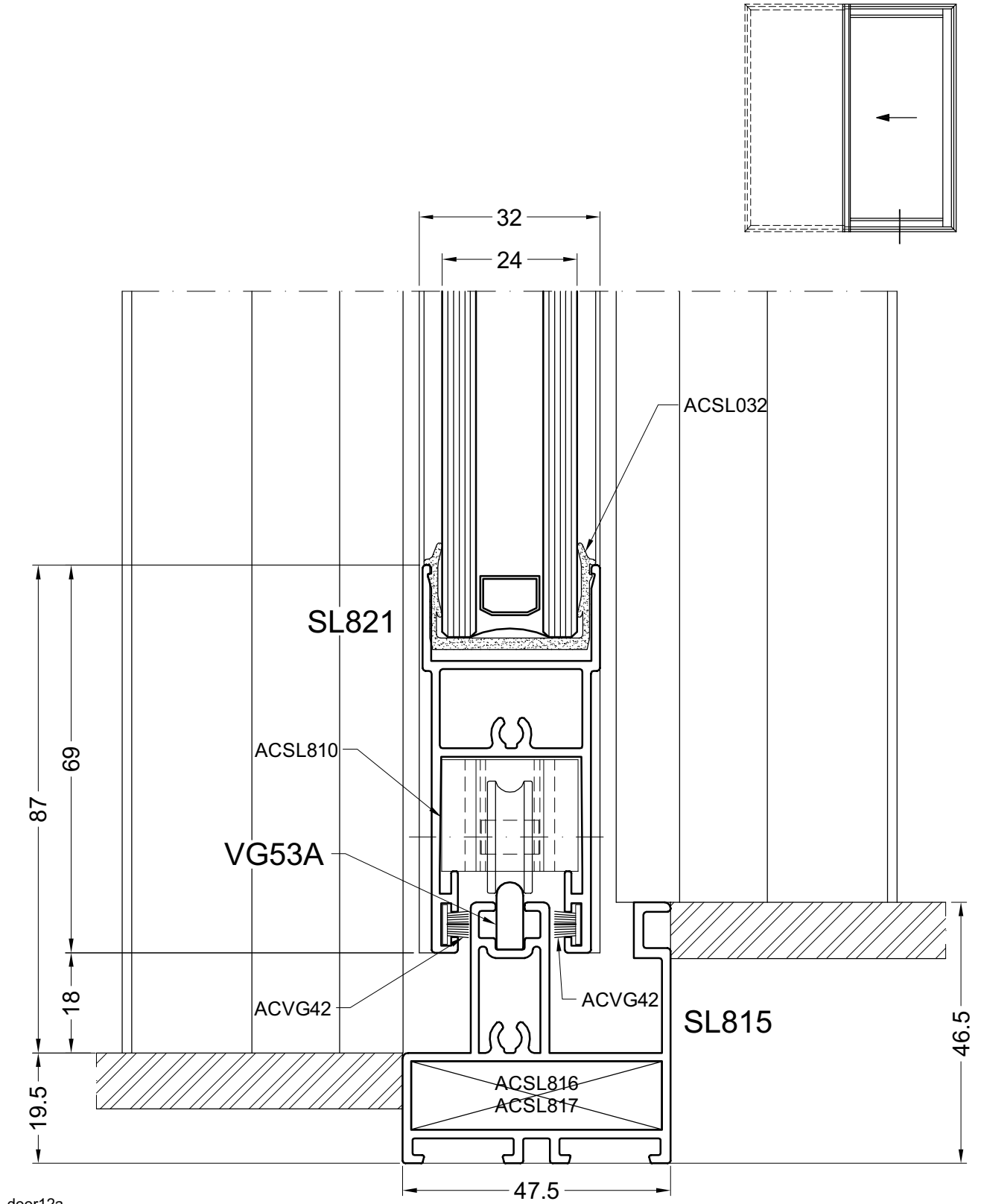

door12a

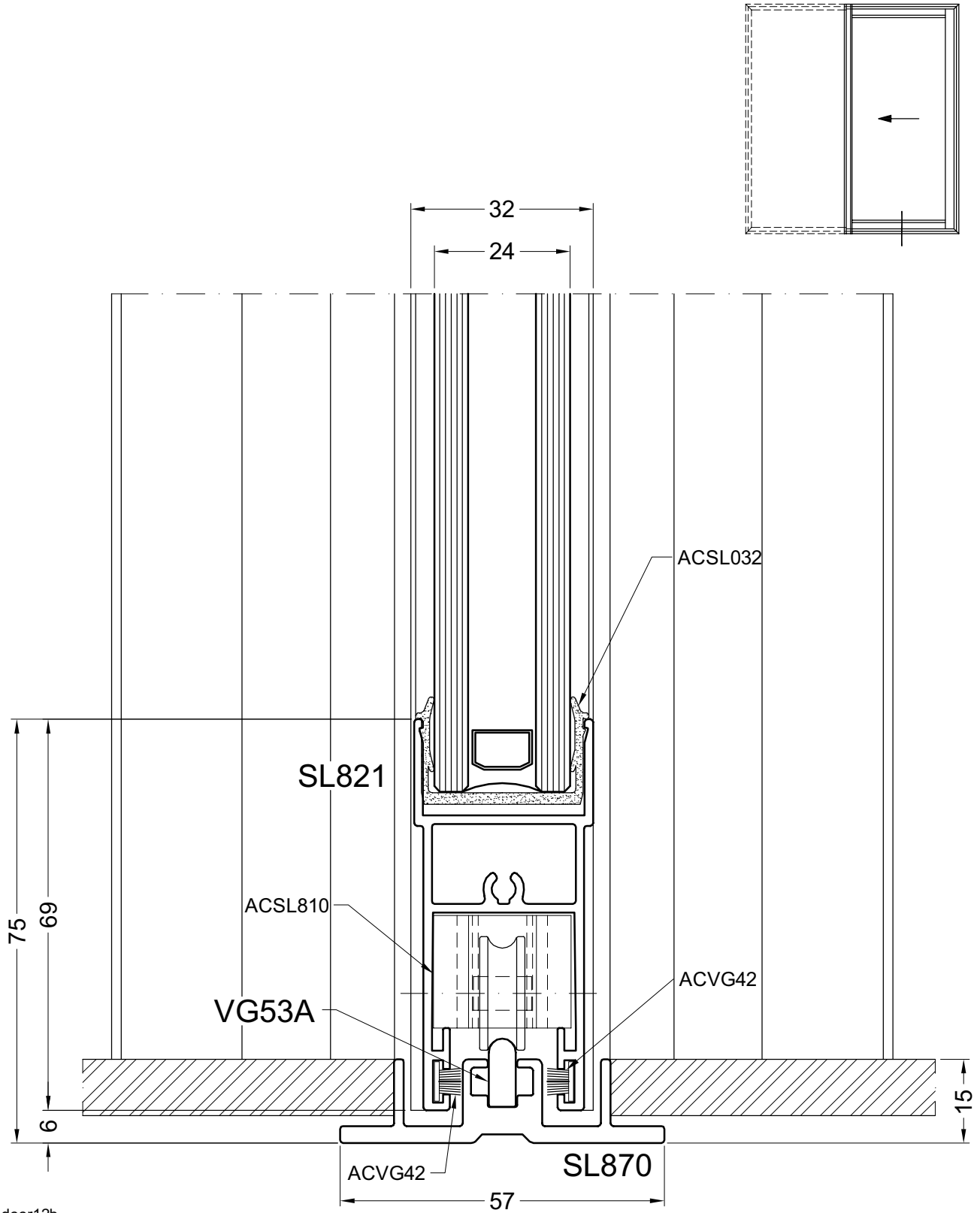

door12b

3

DOORSNEDE - COUPE - SCHNITT - SECTION

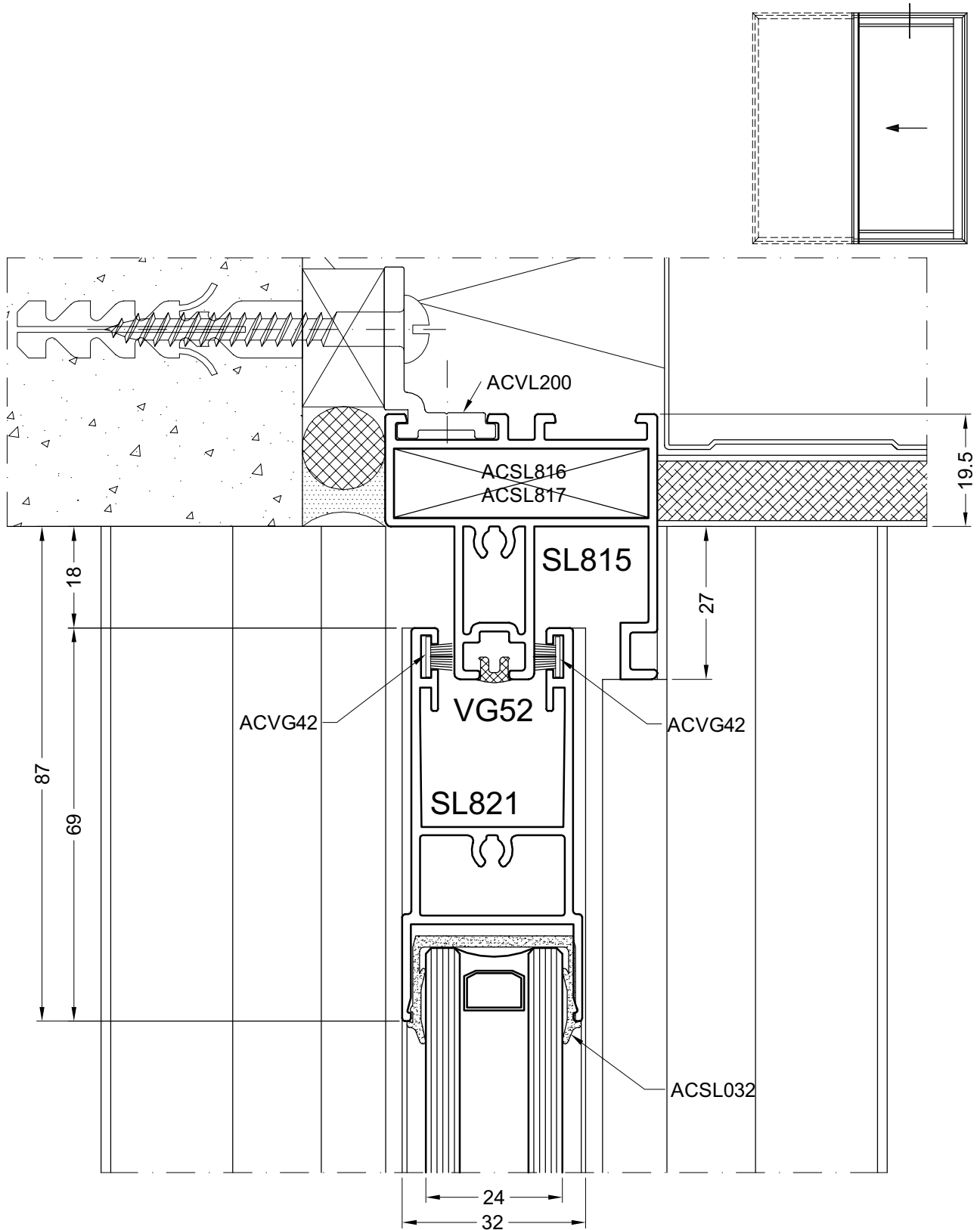

door13

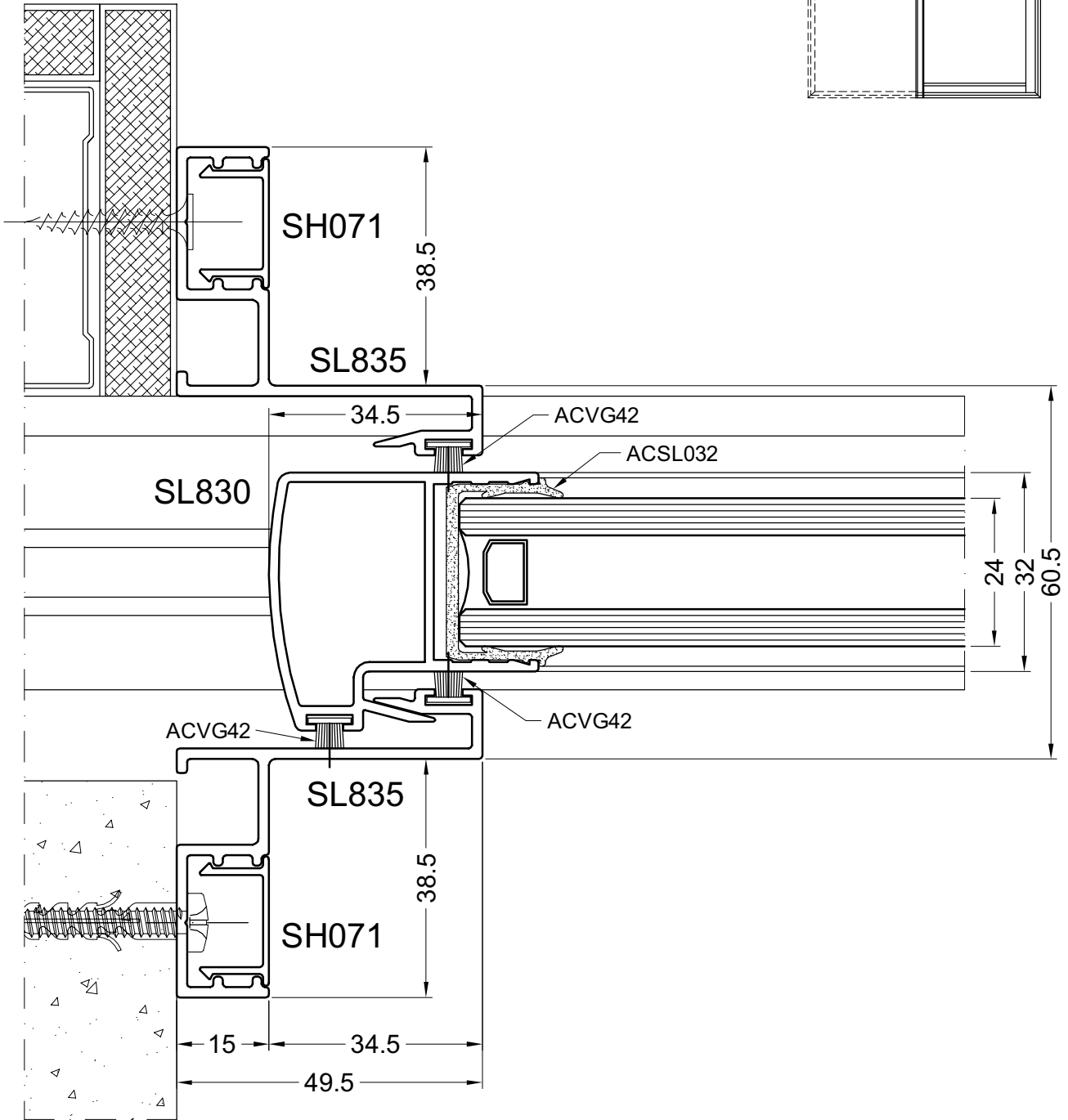
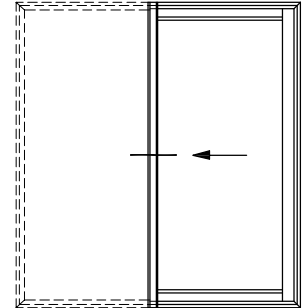

door14

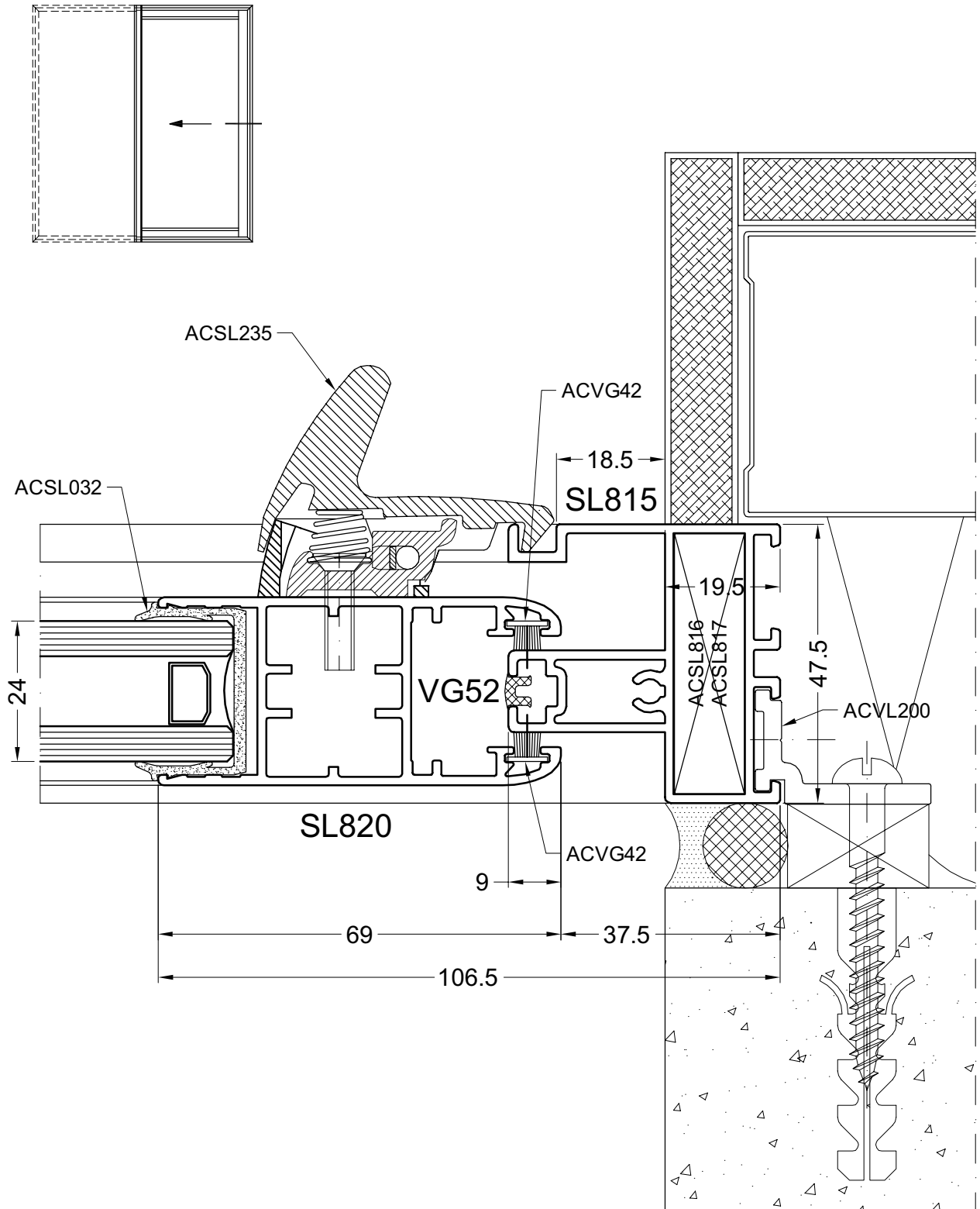

door15

6

DOORSNEDE - COUPE - SCHNITT - SECTION

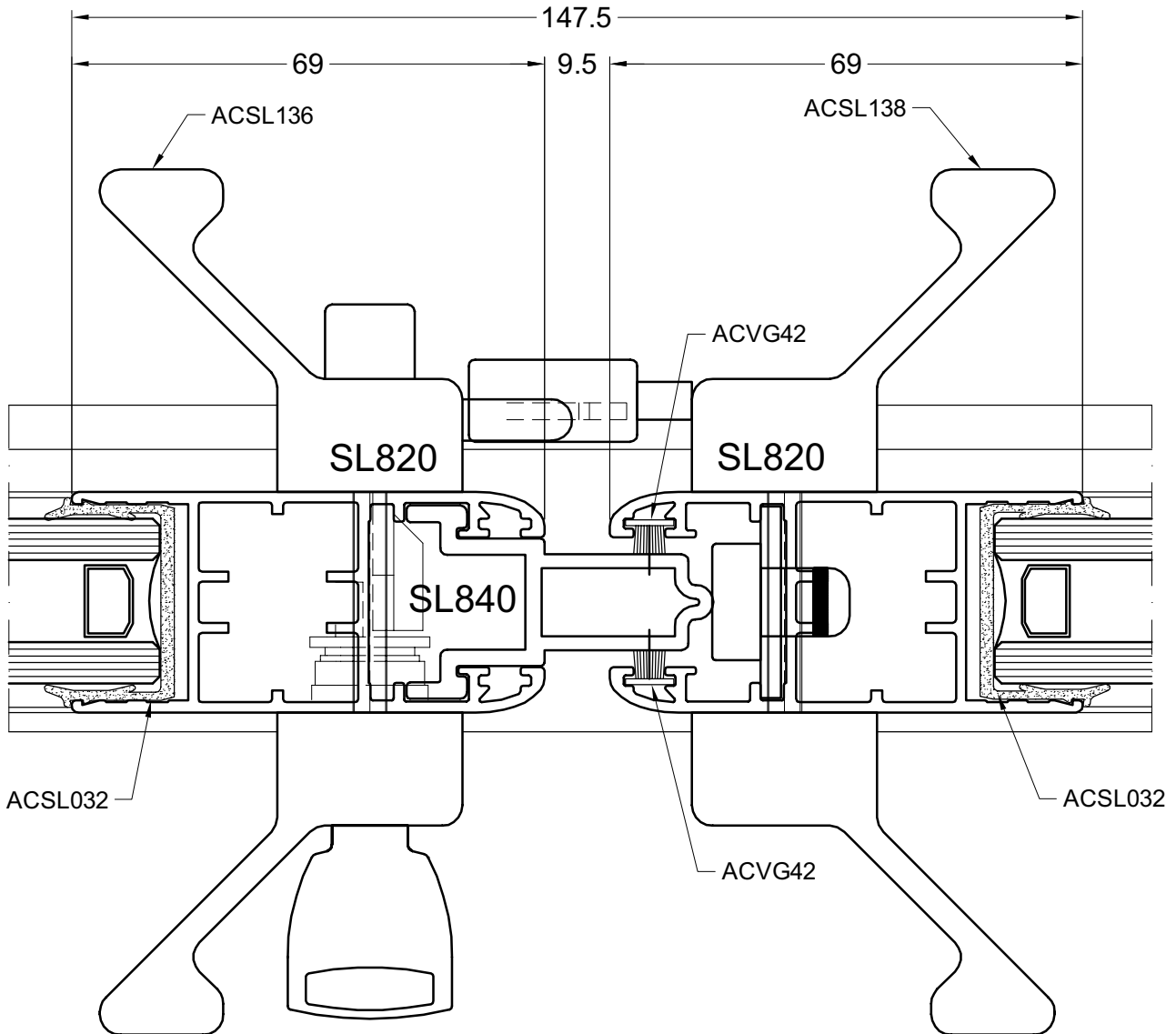
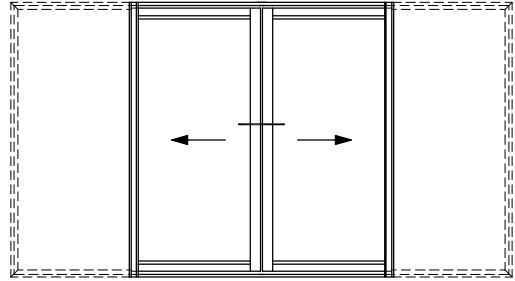

door16

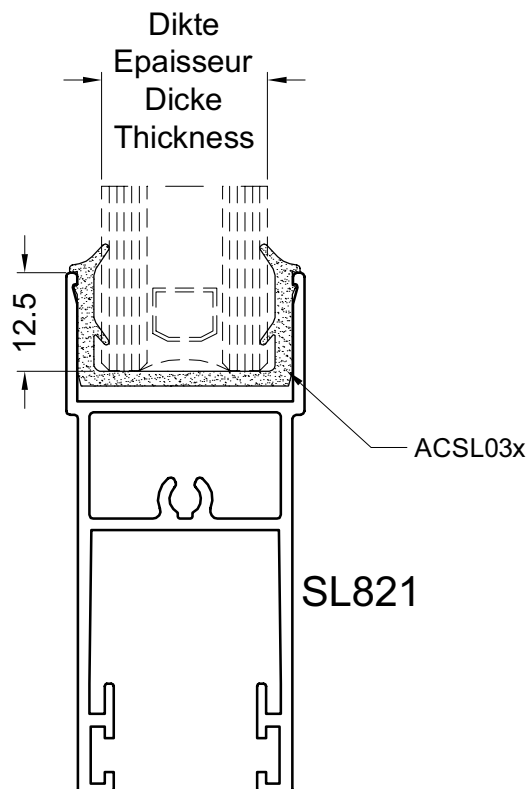

Glasdikte (mm) Epaisseur de verre (mm) Glas dicke (mm) Glass thickness (mm)	Beglazingsrubber Joint de vitrage Glasdichtung Glazing gasket
20	ACSL031
21	ACSL031
22	ACSL032
23	ACSL032
24	ACSL032/ACSL332
6-9	ACSL033

tabel

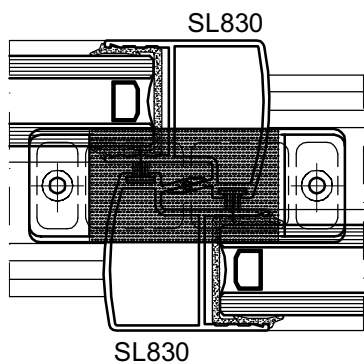
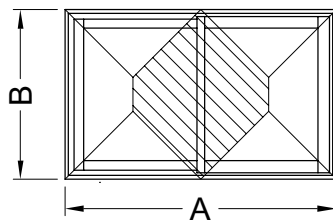

$I_{xx} = 11.9 \text{ cm}^4$
 $f_{max} = B/360 < 8\text{mm}$

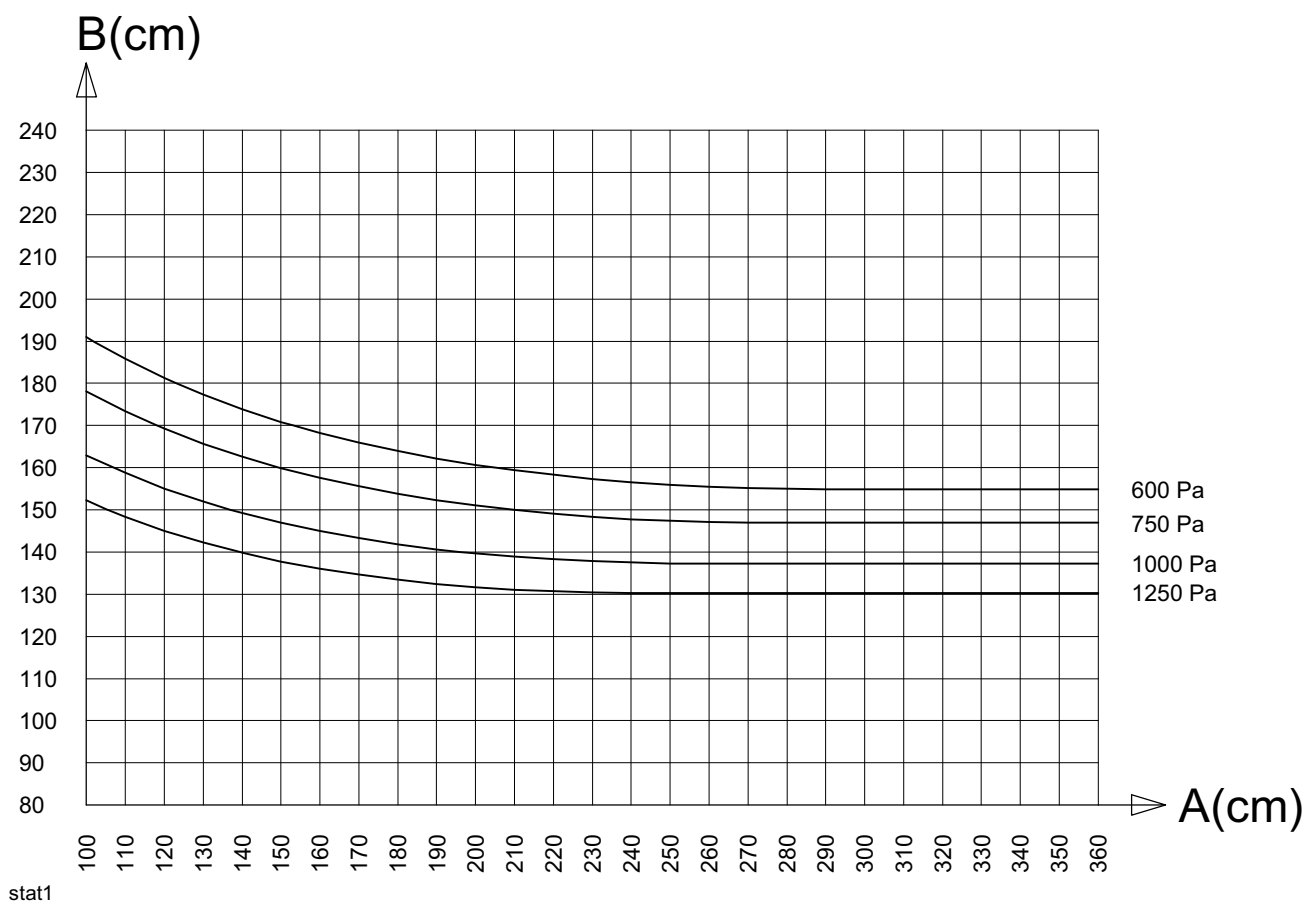

stat1

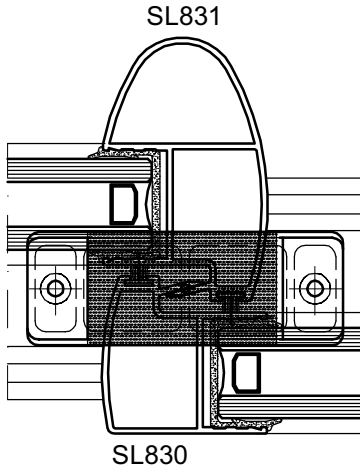
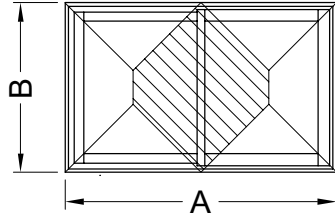

$I_{xx} = 23.79 \text{ cm}^4$
 $f_{max} = B/360 < 8\text{mm}$

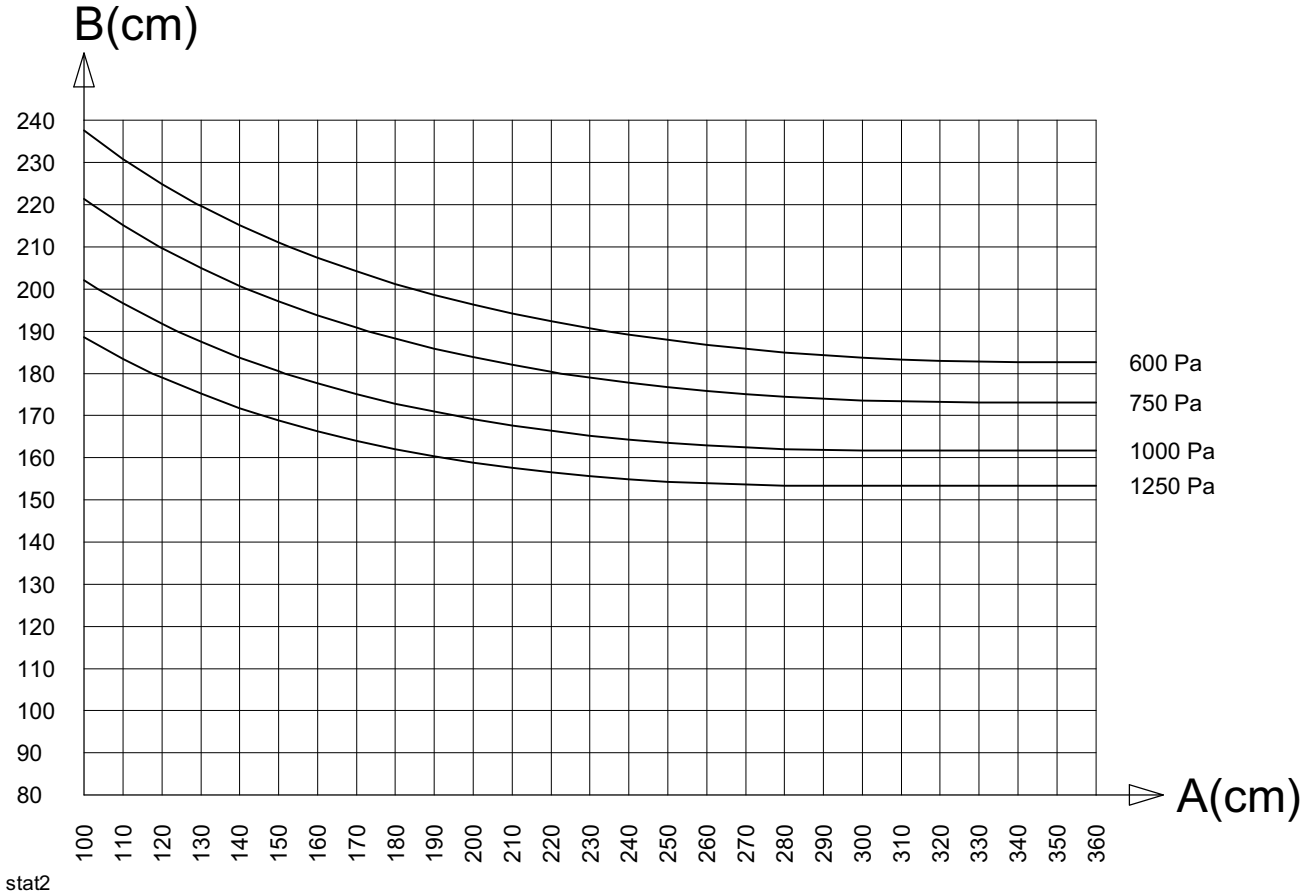

stat2

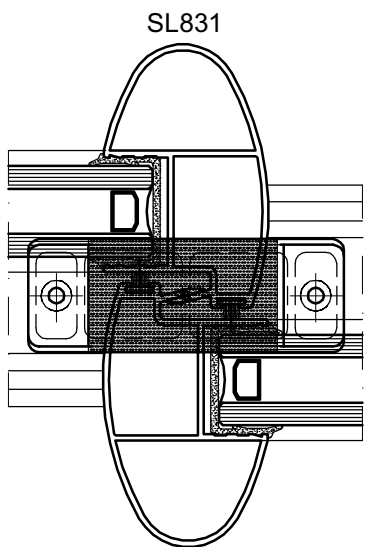
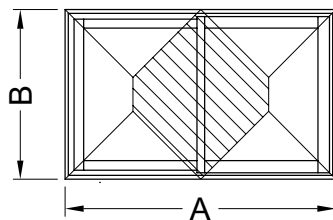

$I_{xx} = 35.68 \text{ cm}^4$
 $f_{max} = B/360 < 8\text{mm}$

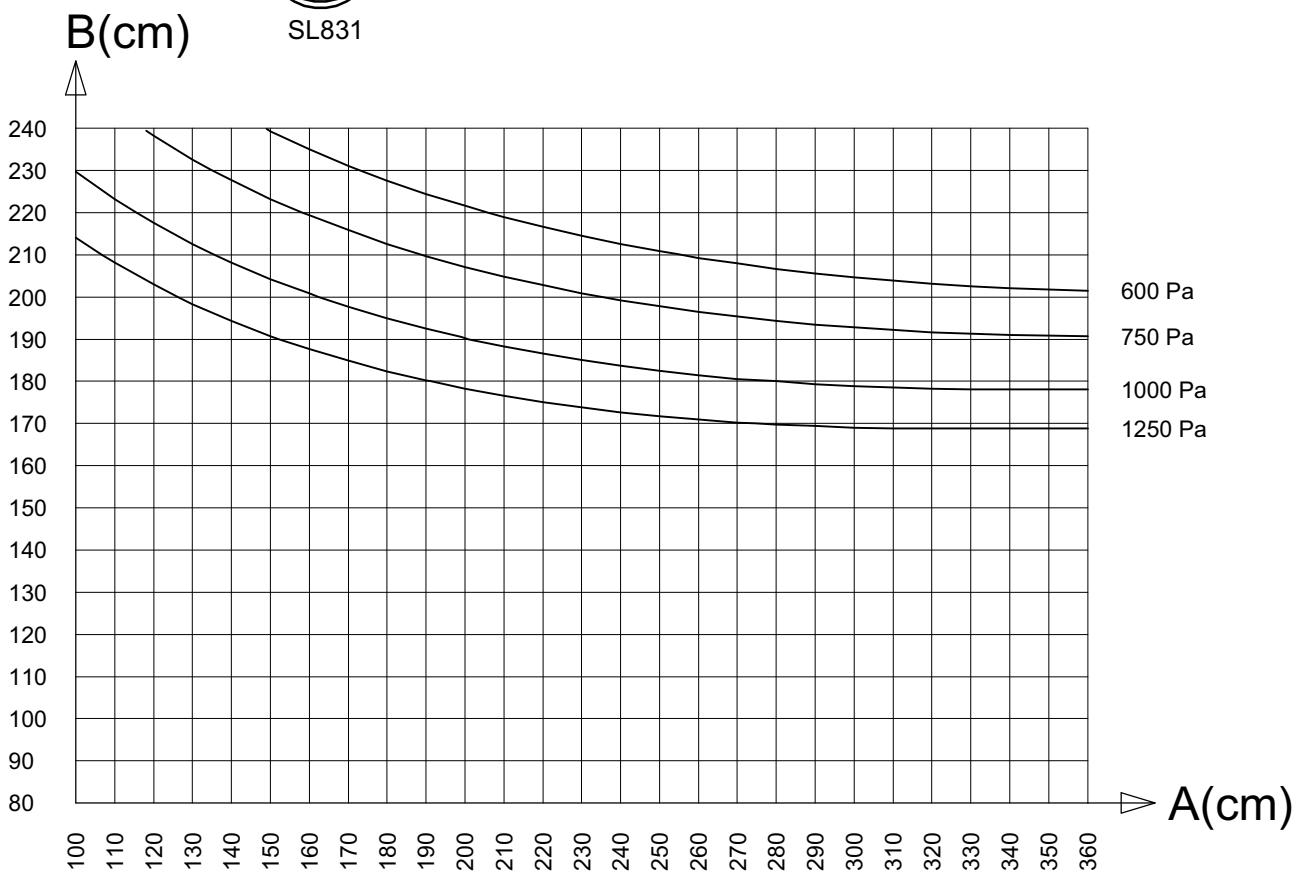

stat3

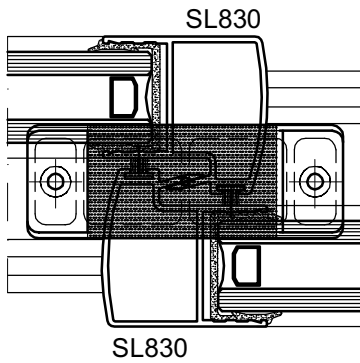
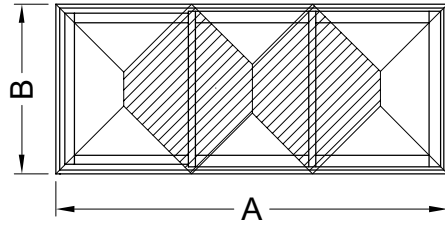

$I_{xx} = 11.9 \text{ cm}^4$
 $f_{max} = B/360 < 8\text{mm}$

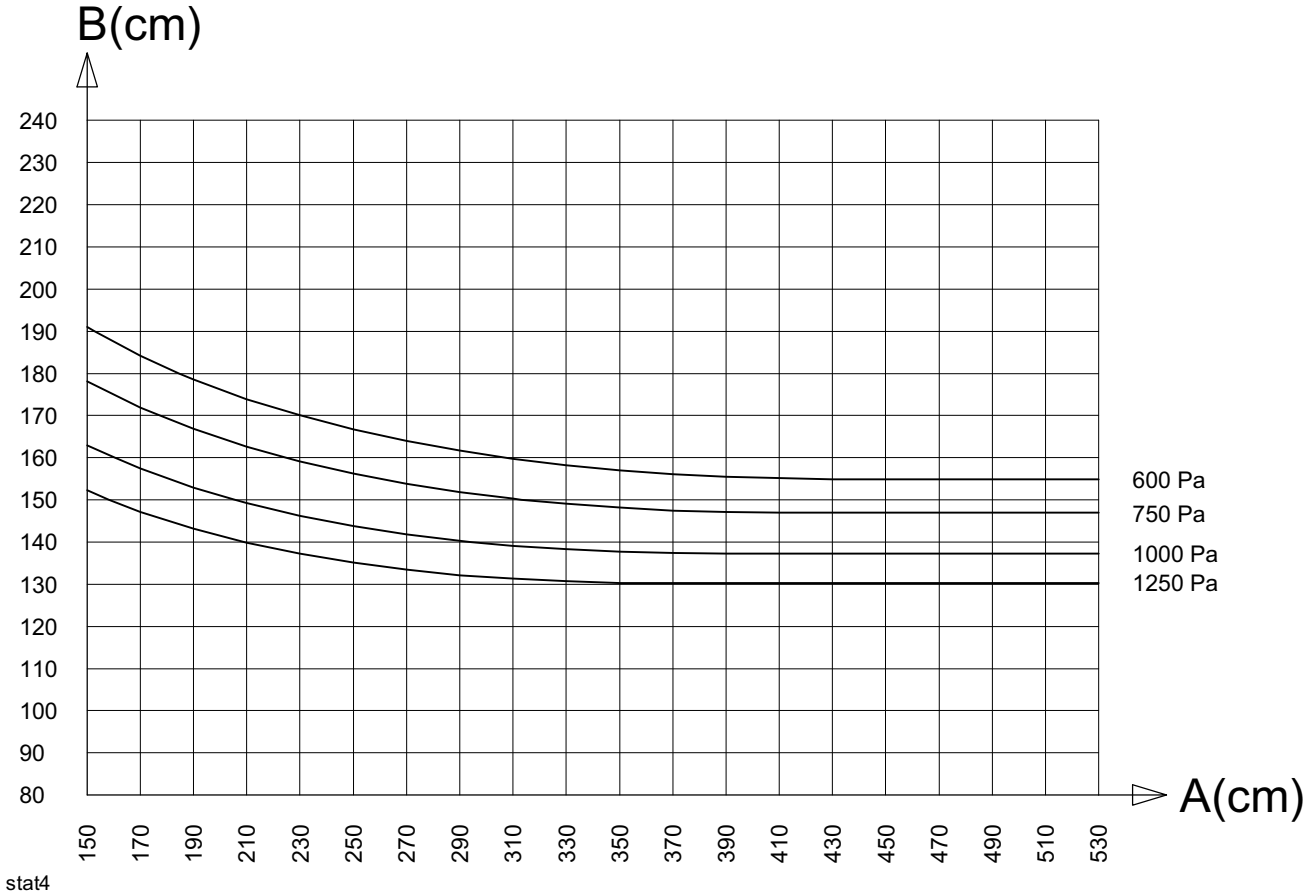

stat4

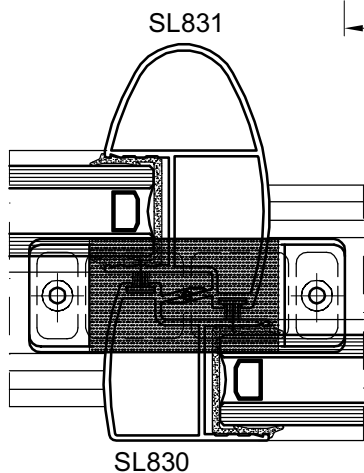
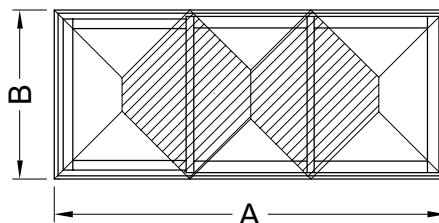

$I_{xx} = 23.79 \text{ cm}^4$
 $f_{max} = B/360 < 8\text{mm}$

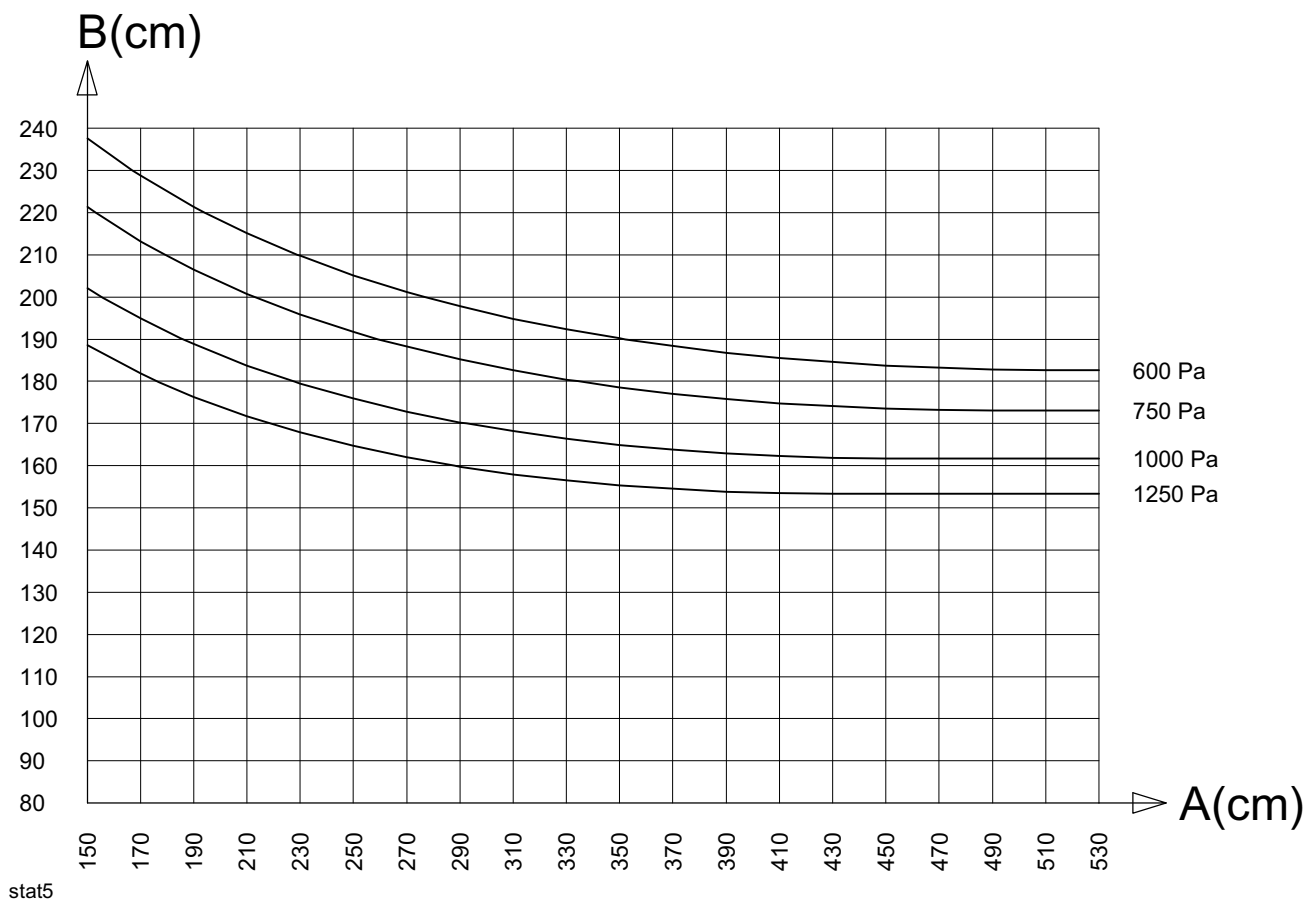

stat5

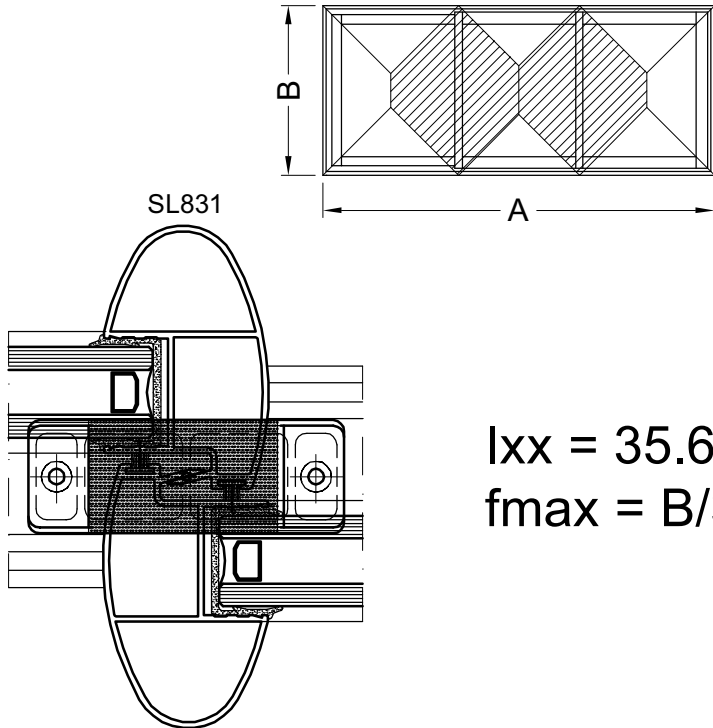

$I_{xx} = 35.68 \text{ cm}^4$
 $f_{max} = B/360 < 8\text{mm}$

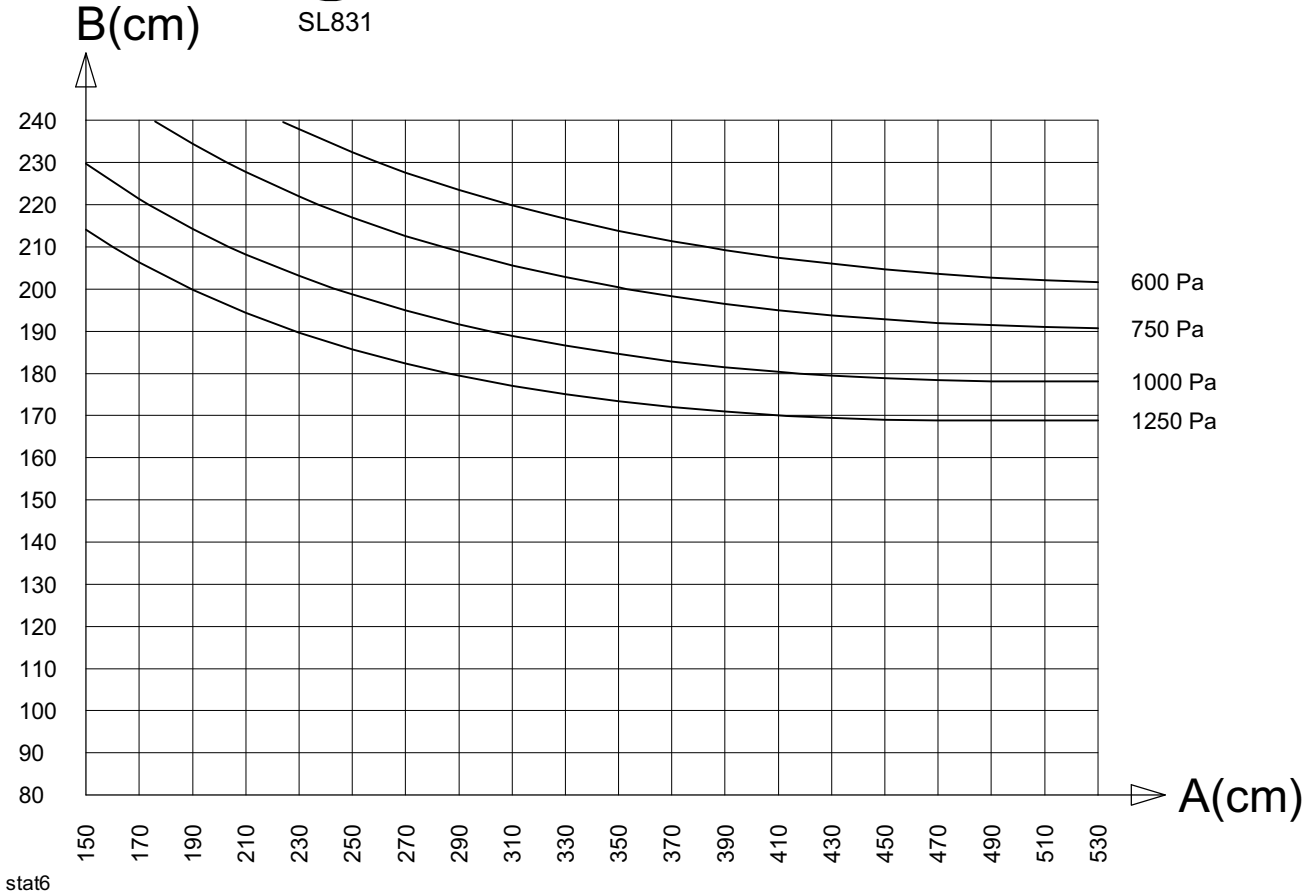

stat6

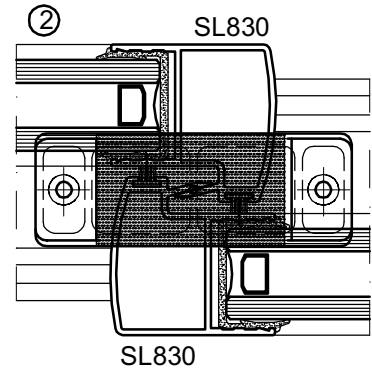
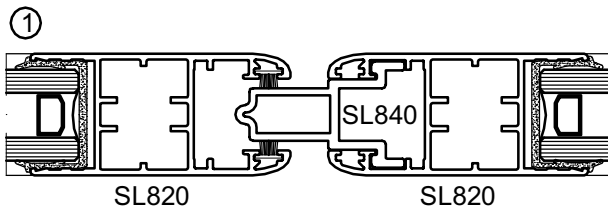
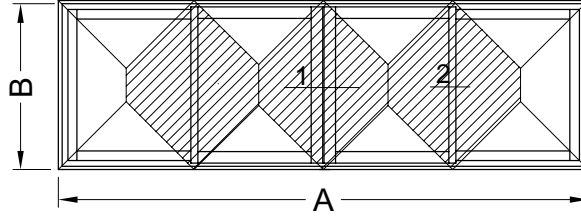

$I_{xx} = 11.9 \text{ cm}^4$
 $f_{max} = B/360 < 8\text{mm}$

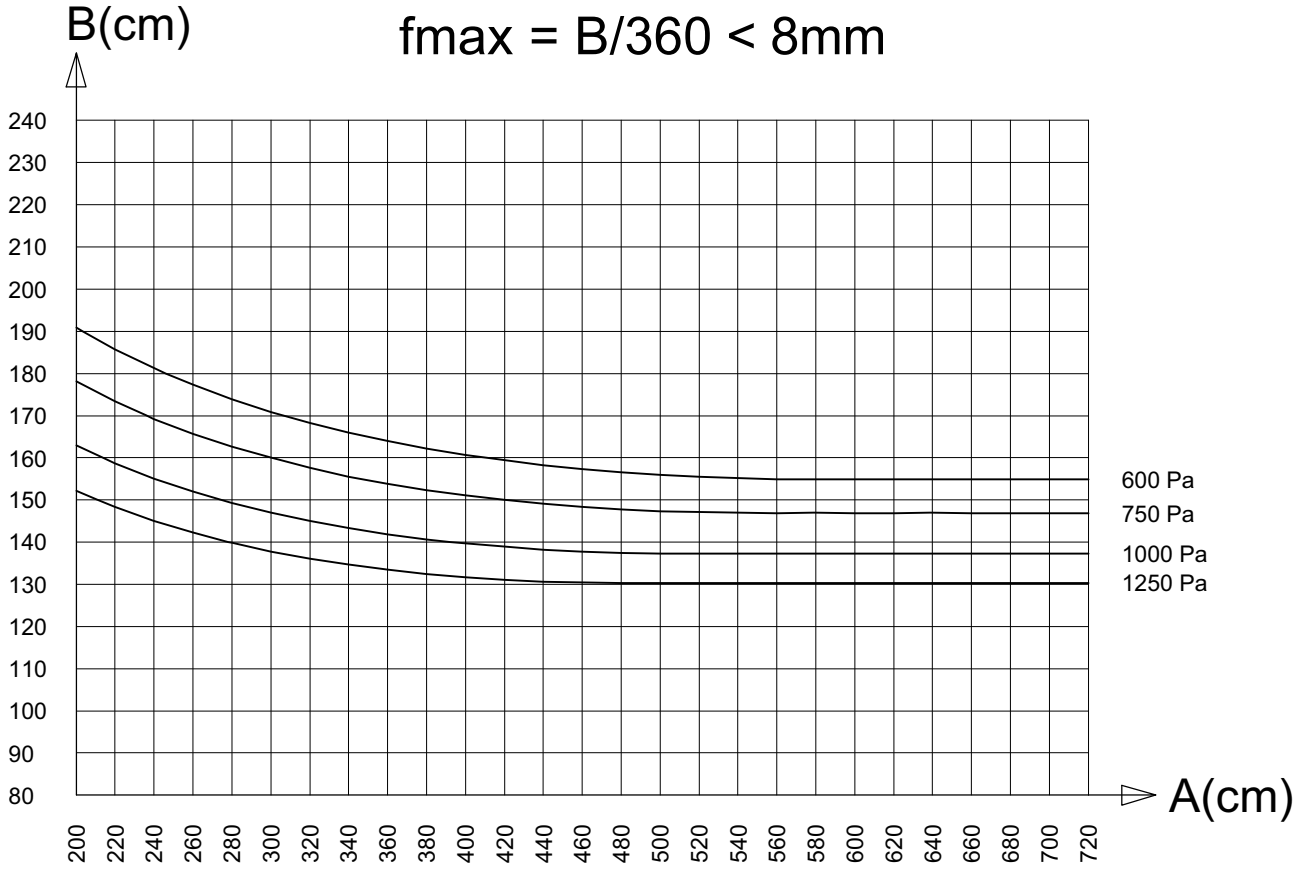

stat7

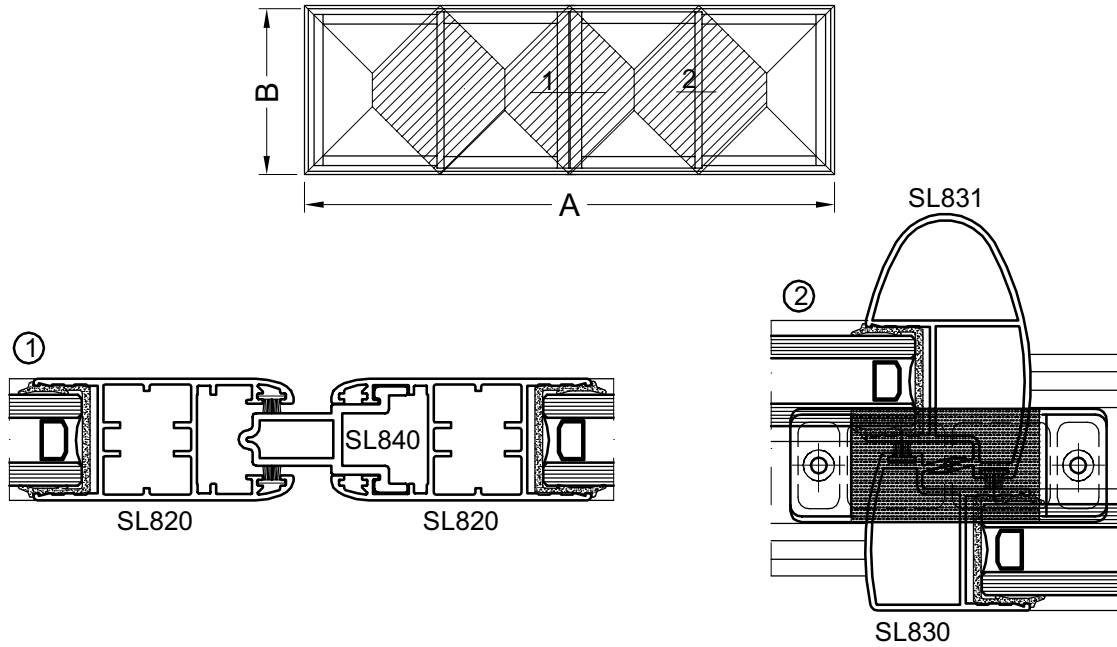

$I_{xx} = 14.61 \text{ cm}^4$
 $f_{max} = B/360 < 8\text{mm}$

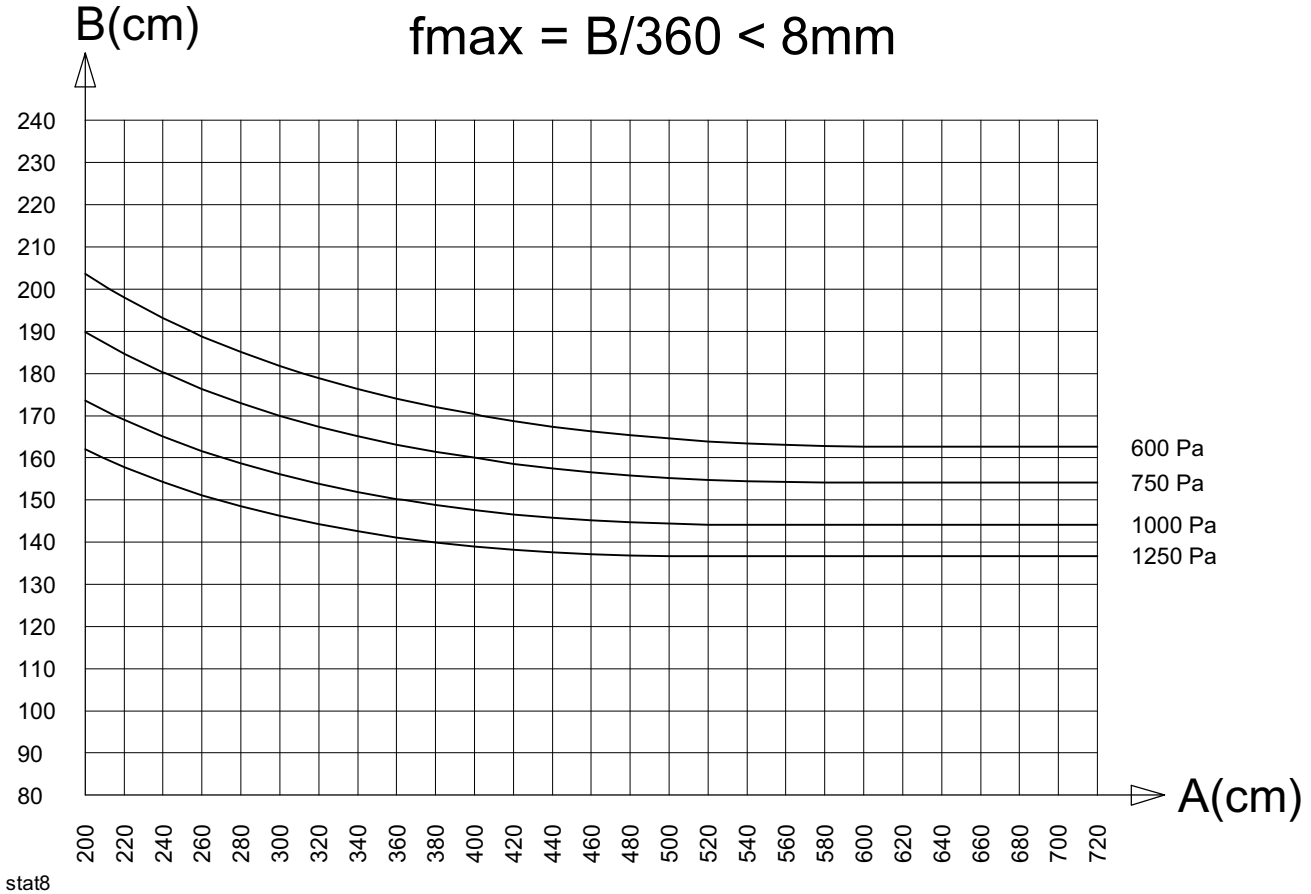

stat8

STATICA - STATIQUE - STATIK - STATICS

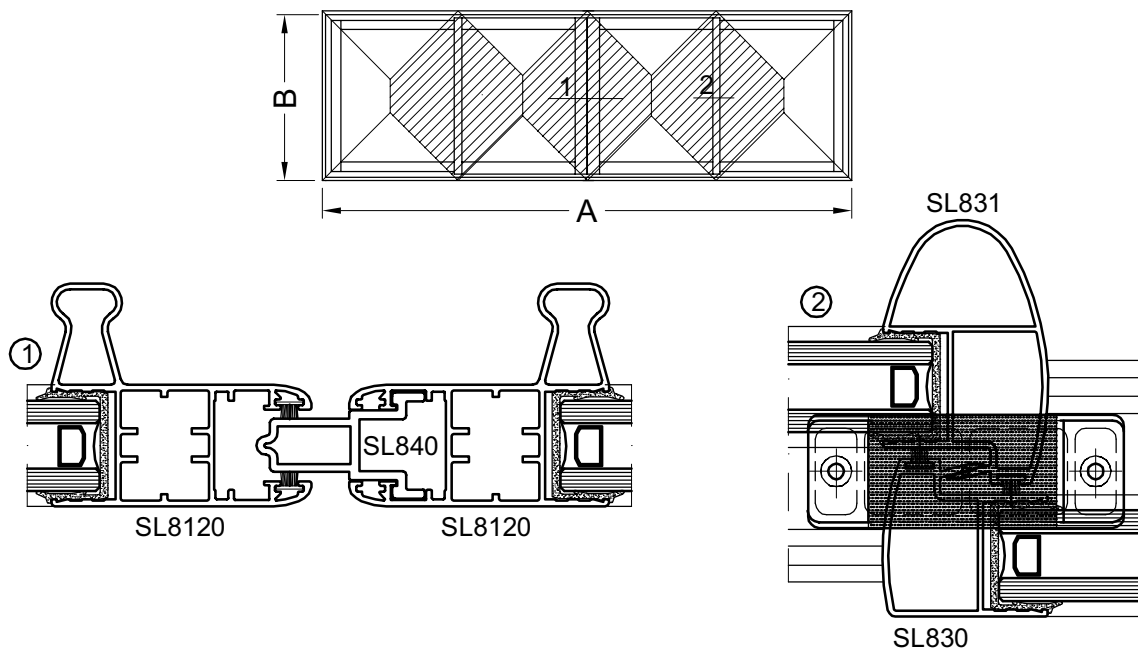

$I_{xx} = 23.79 \text{ cm}^4$
 $f_{max} = B/360 < 8\text{mm}$

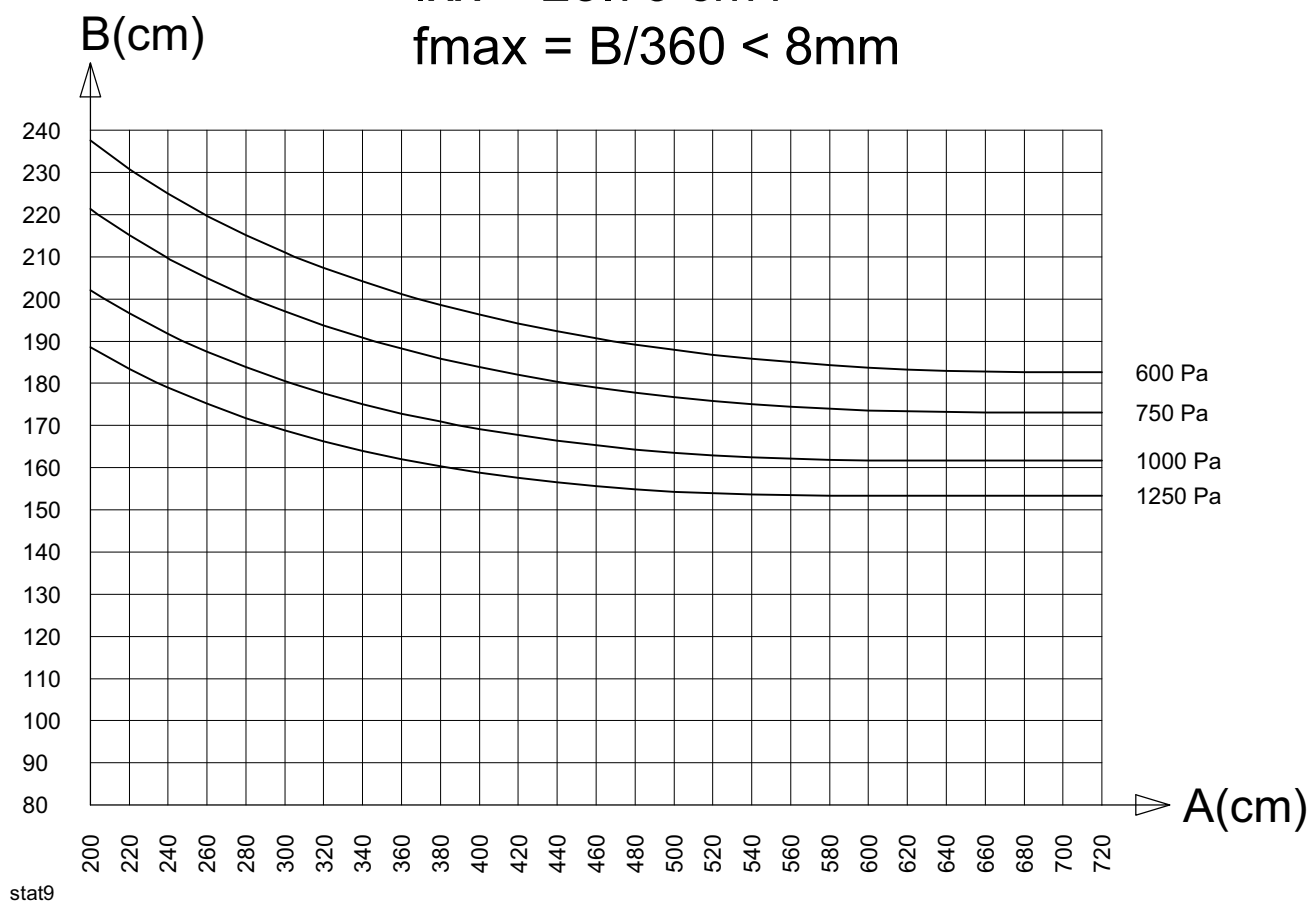

stat9

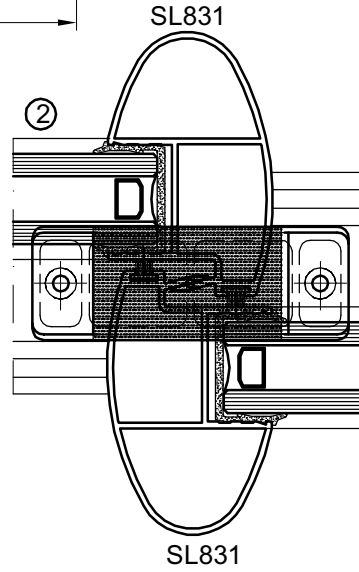
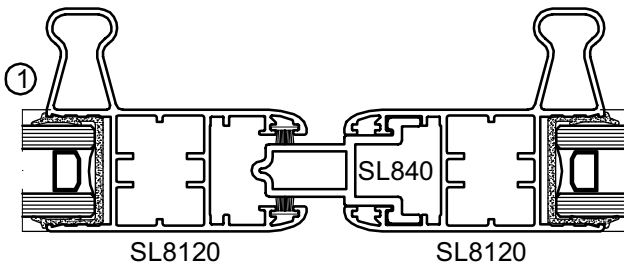
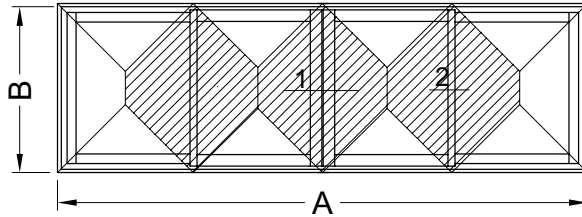

$I_{xx} = 32.67 \text{ cm}^4$
 $f_{max} = B/360 < 8\text{mm}$

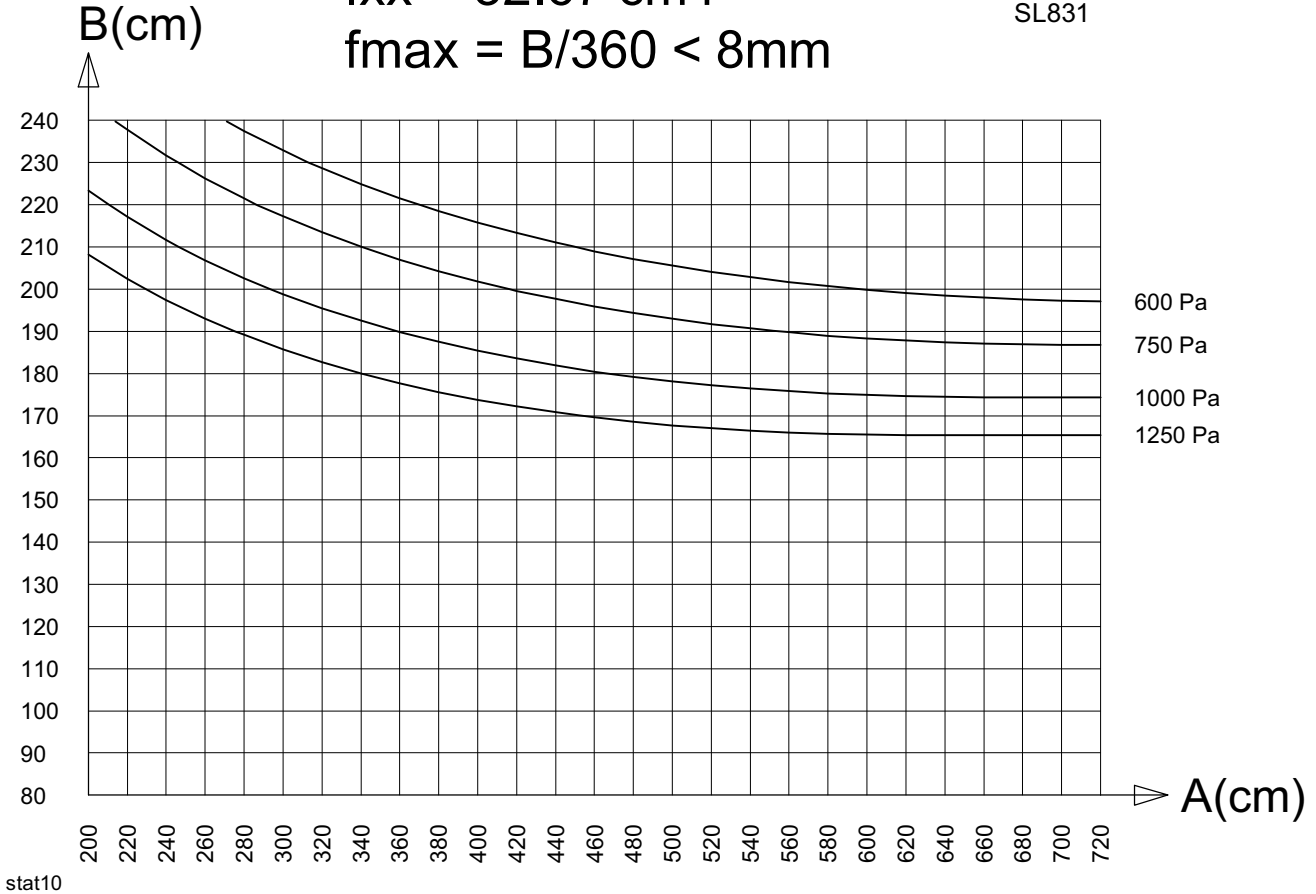

stat10

1 VLEUGELIG SCHUIFRAAM
FENETRE COULISSANTE 1 VANTAUX
SCHIEBEFENSTER 1 FLÜGEL
SLIDING WINDOW WITH ONE PANEL

ZAAGTABELLEN - TABLES DE SCIAGES - ZUSCHNITT-TABELLEN - SAWING TABLES

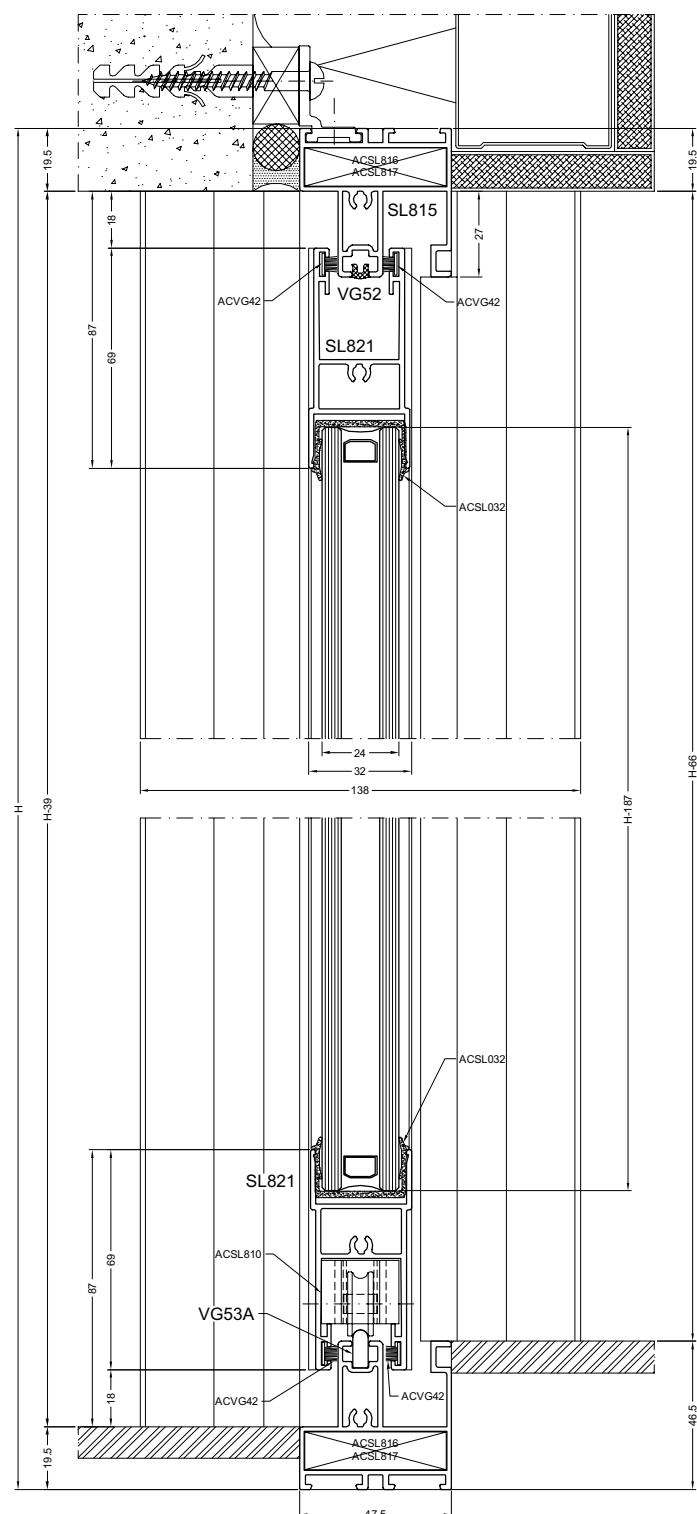

PROFIELEN PROFILES PROFILE PROFILS

SL815		2		B
SL815		2		H
SL820		1		H-79
SL821		2		B2-131
SL830		1		H-75
SL835		1		H-39
SL835		1		H-66
SH071		1		H-39
SH071		1		H-66
VG53A		1		B-85
VG52		1		B-85
VG52		2		H-93

	ACSL810	ACSL811
Maximaal vleugelgewicht		
Poids maximum par vantail	80kg	160kg
Maximaal flügelgewicht		
Max. weight of the vent		

GLASMATEN		
DIMENSIONS DES VITRAGES	1X	B2-139.5
GLASMASSE		H-187
GLASS SIZES		

TOEBEHOREN ACCESSOIRES
ZUBEHÖRTEILE ACCESSORIES

ACSL810/ACSL811	2
ACSL816/ACSL817	4
ACSL03X	2H+2B2-450
ACSL021	2
ACSL022	2
ACVG42	5H+4B2-200
ACSL235	1

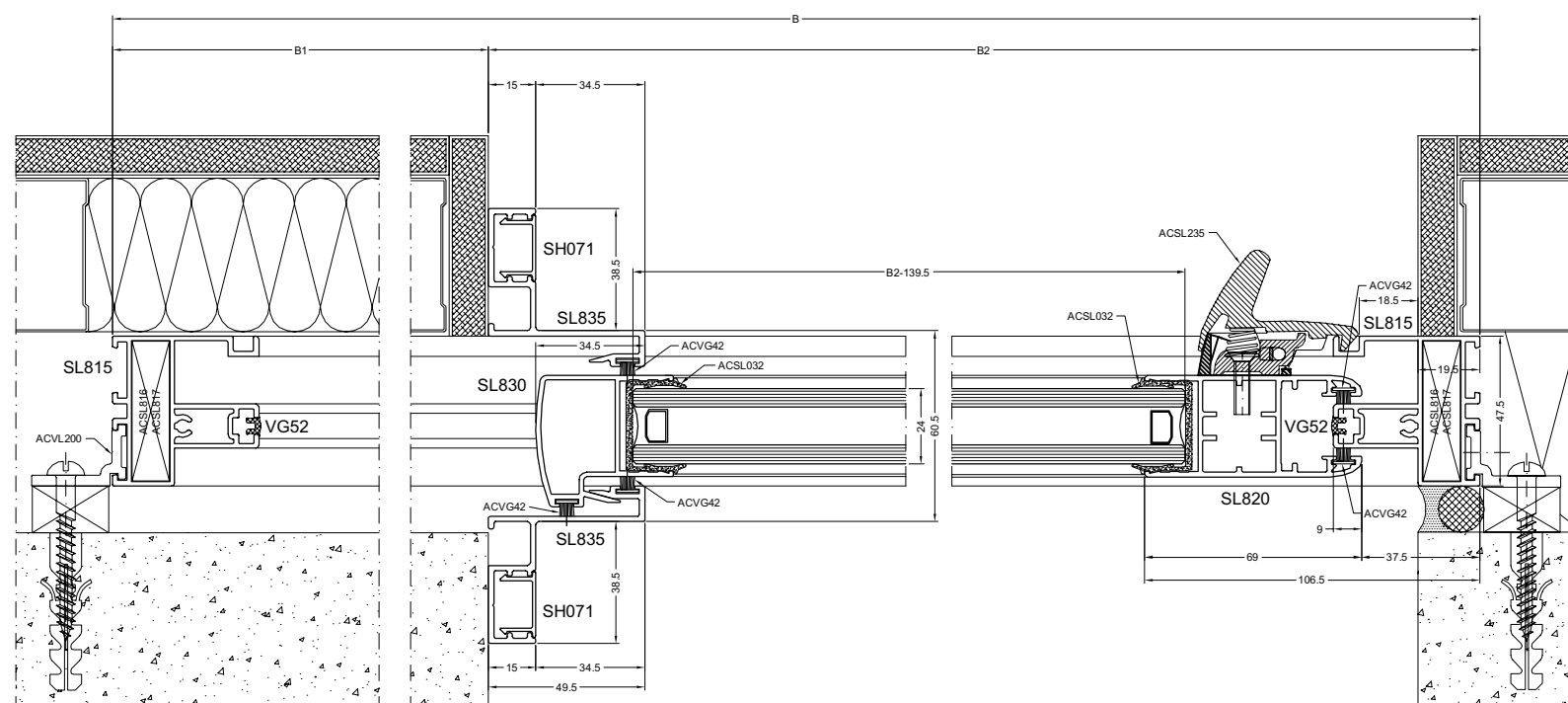
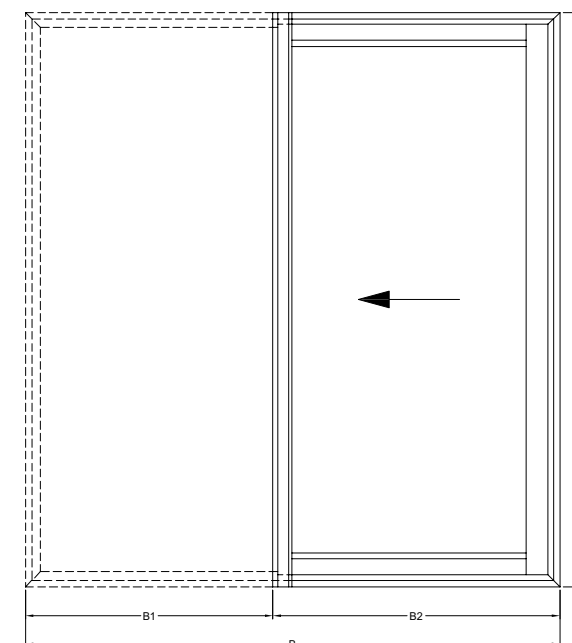
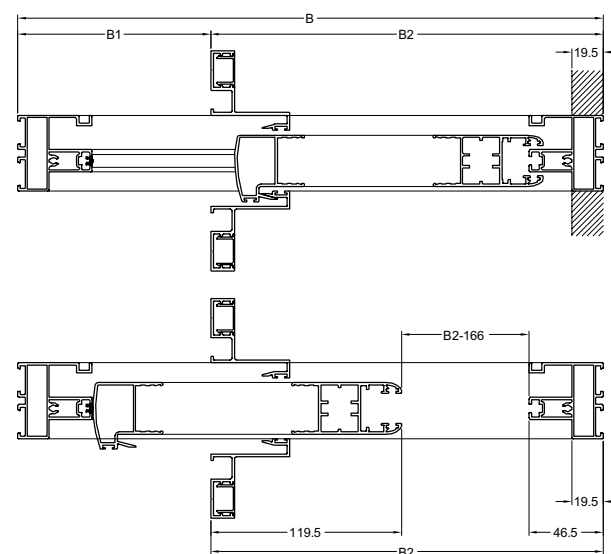

zaag1

2 VLEUGELIG SCHUIFRAAM
FENETRE COULISSANTE DEUX VANTAUX
SCHIEBEFENSTER 2 FLUGEL
DOUBLE SLIDING WINDOW

ZAAGTABELLEN - TABLES DE SCIAGES - ZUSCHNITT-TABELLEN - SAWING TABLES

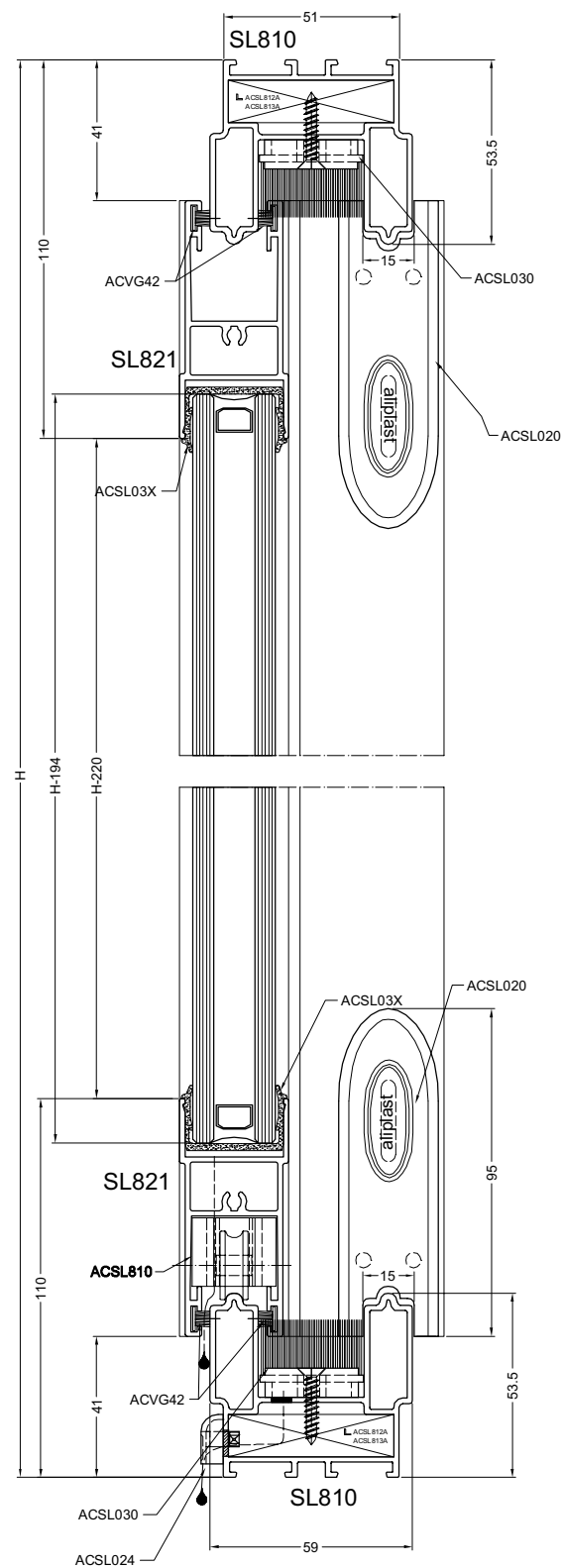

PROFIELN PROFILES PROFILE PROFILS

SL810		2		B
SL810		2		H
SL820		2		H-86
SL821		4		B/2-98
SL830		2		H-82

	ACSL810	ACSL811
Maximaal vleugelgewicht Poids maximum par vantail Maximaal flügelgewicht Max. weight of the vent	80kg	160kg

TOEBEHOREN ACCESSOIRES

ZUBEHÖRTEILE ACCESSORIES

ACSL810/ACSL811	4
ACSL812A/813A	4
ACSL020	4
ACSL030	1
ACSL03X	4H+2B-1100
ACSL24X	2
ACSL248	2
ACSL021	4
ACSL022	4
ACSL035	2
ACVG42	6H+4B-1200
ACSL024	2

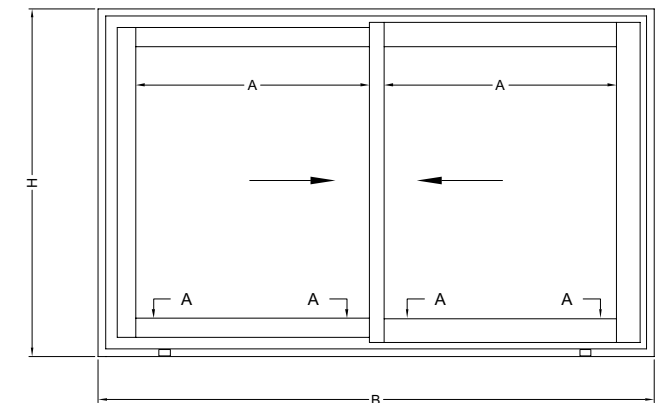

GLASMATEN
DIMENSIONS DES VITRAGES
GLASMASSE
GLASS SIZES

2X B/2-106
H-194

A GLASSPONNING ONTLUCHTING 8 x Ø8
VENTILATION FEUILLURE
LUFTUNG ANSCHLAG
VENTILATION GROOVE

B SLEUF 25x7
RAINURE
SCHLITZ
SLOT

C AFDEKKAPJE WATERAFVOER
CAPUCHON ECOULEMENT D'EAU
ABDECKKAPPE ENTWASSERUNG
DRAIN HOLE COVER

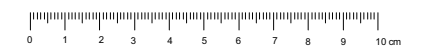
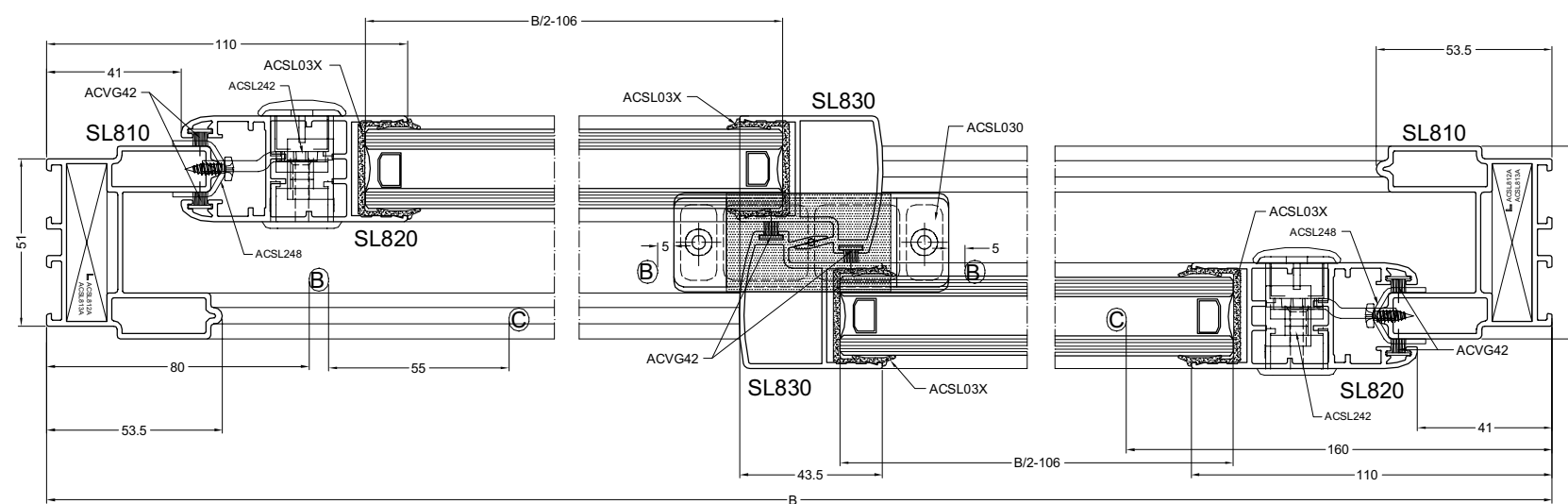

zaagsl1

2 VLEUGELIG SCHUIFRAAM
FENETRE COULISSANTE DEUX VANTAUX
SCHIEBEFENSTER 2 FLUGEL
DOUBLE SLIDING WINDOW

ZAAGTABELLEN - TABLES DE SCIAGES - ZUSCHNITT-TABELLEN - SAWING TABLES

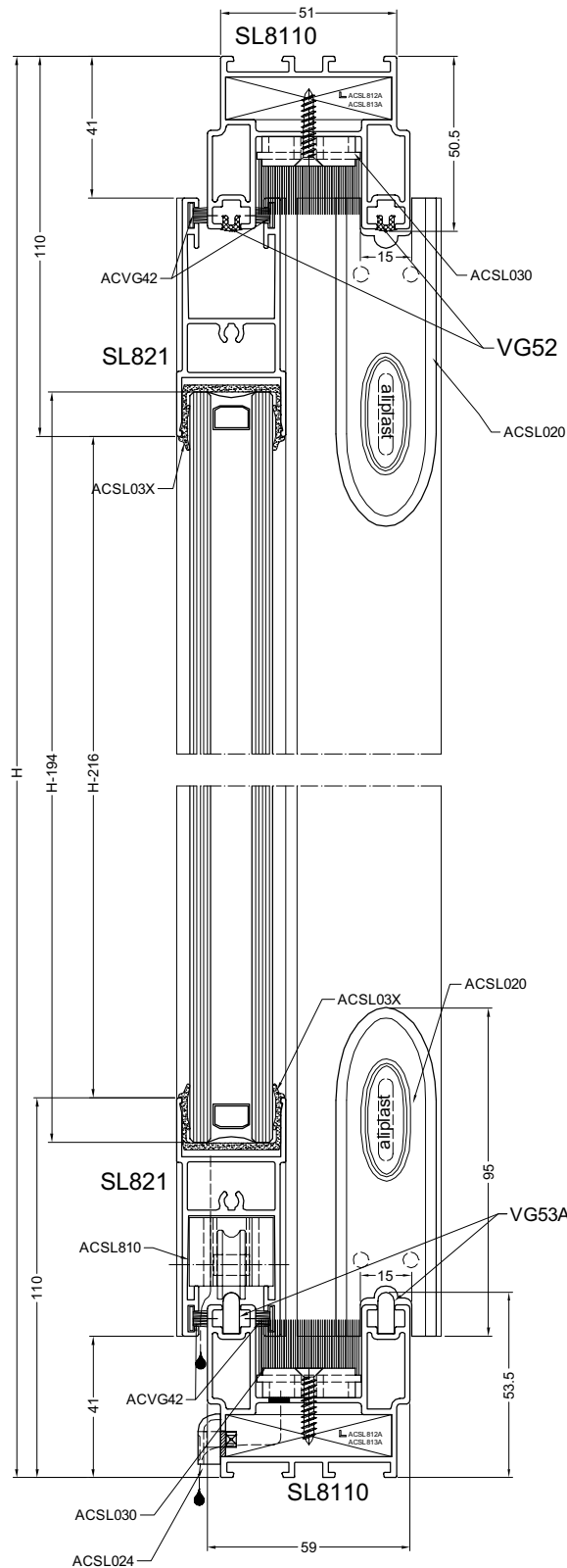

PROFIELN PROFILES PROFILE PROFILS

SL8110		2		B
SL8110		2		H
SL820		2		H-86
SL821		4		B/2-98
SL830		2		H-82
VG52		2		B-92
VG52		4		H-104
VG53A		2		B-92

	ACSL810	ACSL811
Maximaal vleugelgewicht Poids maximum par vantail Maximaal flugelgewicht Max. weight of the vent	80kg	160kg

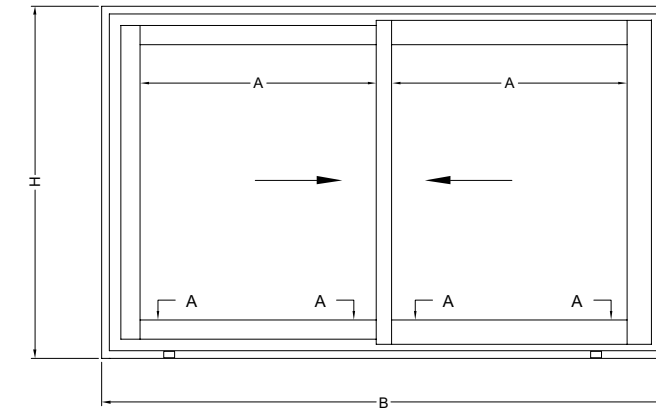

GLASMATEN DIMENSIONS DES VITRAGES GLASMASSE GLASS SIZES	2X	B/2-106 H-194
--	----	------------------

TOEBEHOREN ACCESSOIRES
ZUBEHORTEILE ACCESSORIES

ACSL810/ACSL811	4
ACSL812A/813A	4
ACSL020	4
ACSL030	1
ACSL03X	4H+2B-1100
ACSL24X	2
ACSL246	2
ACSL021	4
ACSL022	4
ACSL035	2
ACVG42	6H+4B-1200
ACSL024	2

A GLASSPONNING ONTLUCHTING 8 x Ø8
VENTILATION FEILLURE
LUFTUNG ANSCHLAG
VENTILATION GROOVE

C AFDEKKAPJE WATERAFVOER
CAPUCHON ECOULEMENT D'EAU
ABDECKKAPPE ENTWASSERUNG
DRAIN HOLE COVER

B SLEUF 25x7
RAINURE
SCHLITZ
SLOT

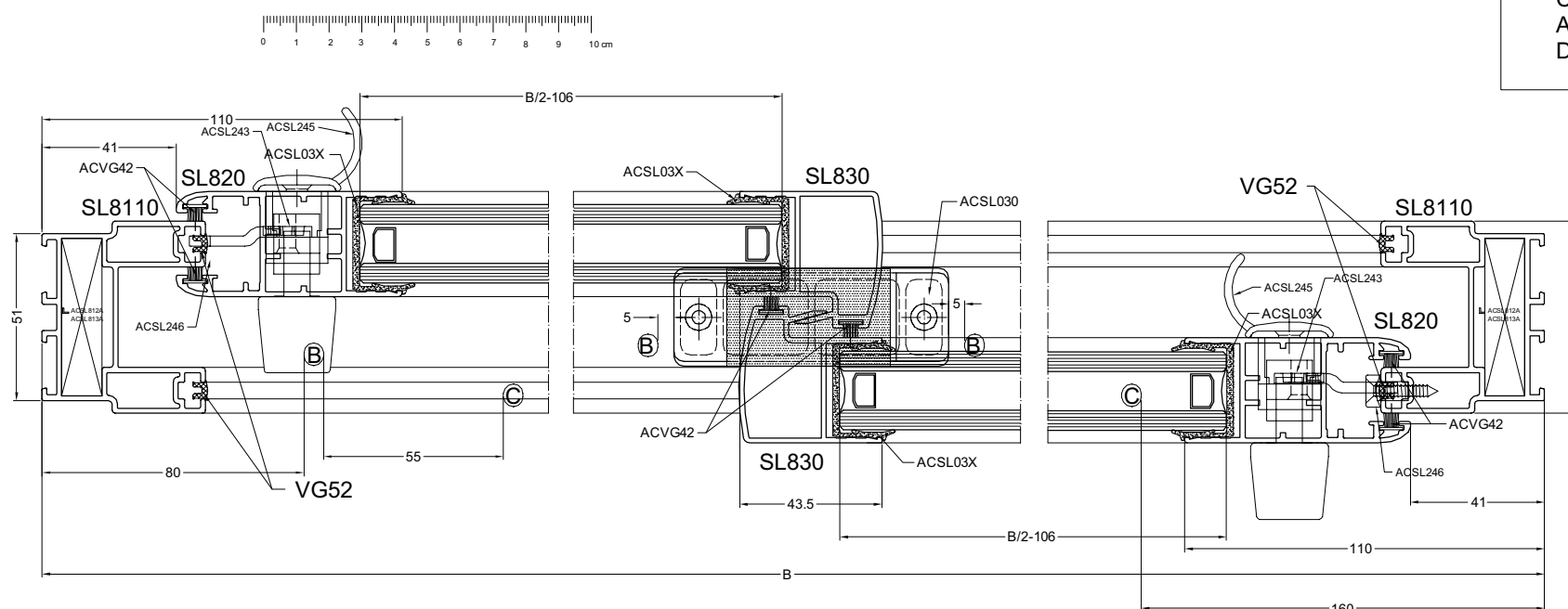

2 VLEUGELIG SCHUIFRAAM
FENETRE COULISSANTE DEUX VANTAUX
SCHIEBEFENSTER 2 FLUGEL
DOUBLE SLIDING WINDOW

ZAAGTABELLEN - TABLES DE SCIAGES - ZUSCHNITT-TABELLEN - SAWING TABLES

PROFIELEN PROFILES PROFILE PROFILS

SL815		2		B
SL815		2		H
SL820		2		H-79
SL821		4		B2/2 -98.5
SL830		2		H-75
SL835		2		H-39
SL835		2		H-66
SL840		1		H-142
SH071		2		H-39
SH071		2		H-66
VG53A		1		B-85
VG52		1		B-85
VG52		2		H-93

TOEBEHOREN ACCESSOIRES
ZUBEHÖRTEILE ACCESSORIES

ACSL810/ACSL811	4
ACSL816/ACSL817	4
ACSL03X	4H+2B2-1500
ACSL021	4
ACSL022	2
ACVG42	8H+4B2-1100
ACSL140	1
ACSL135	1
ACSL136	1
ACSL137	1
ACSL138	1

	ACSL810	ACSL811
Maximaal vleugelgewicht Poids maximum par vantail Maximaal flügelgewicht Max. weight of the vent	80kg	160kg

GLASMATEN DIMENSIONS DES VITRAGES GLASMASSE GLASS SIZES	2X	B2/2 -106.5 H-187
--	----	----------------------

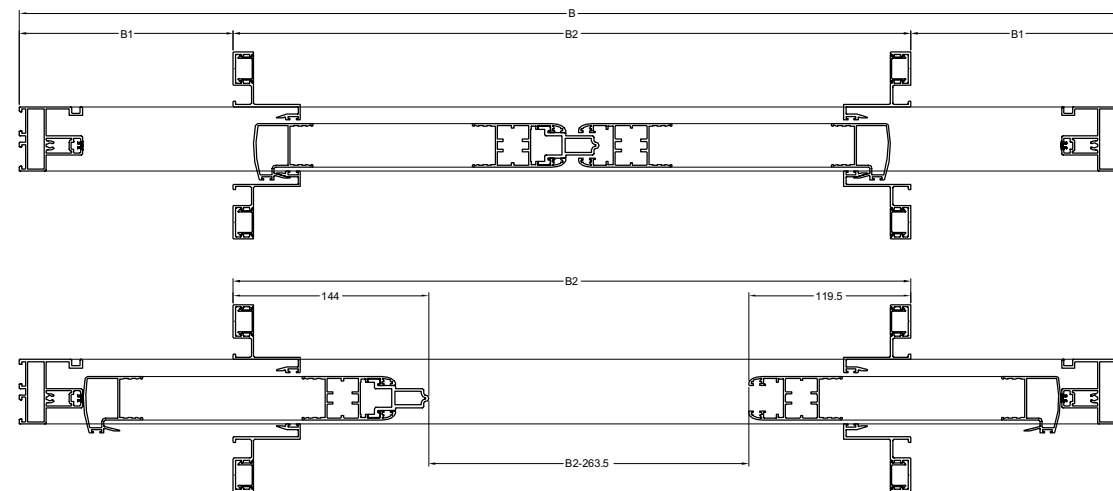
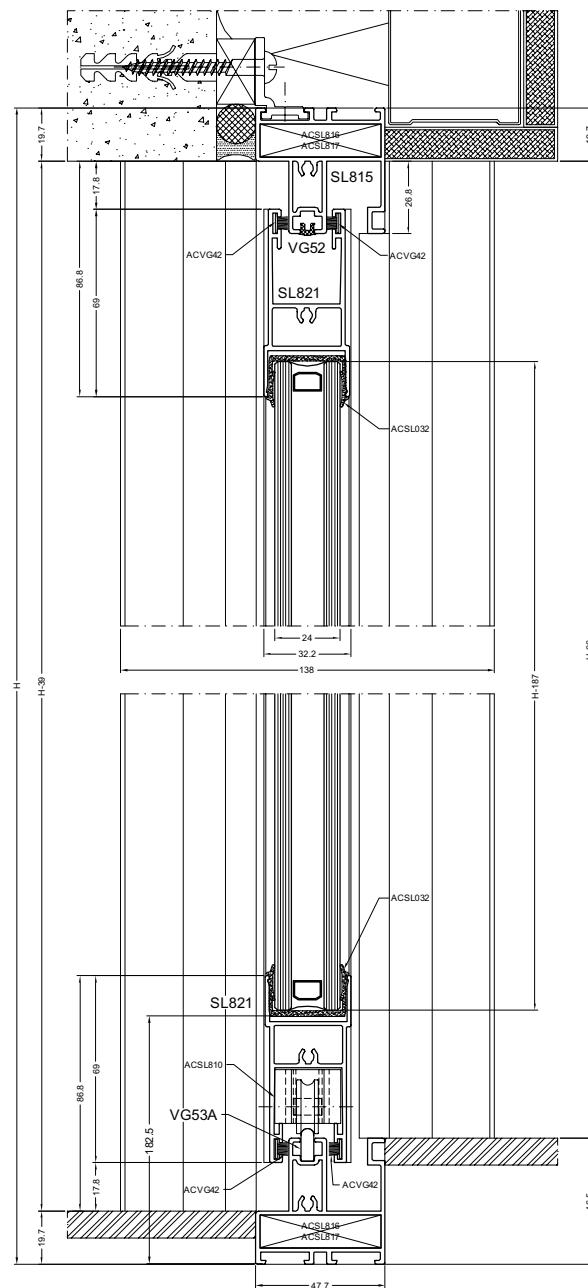
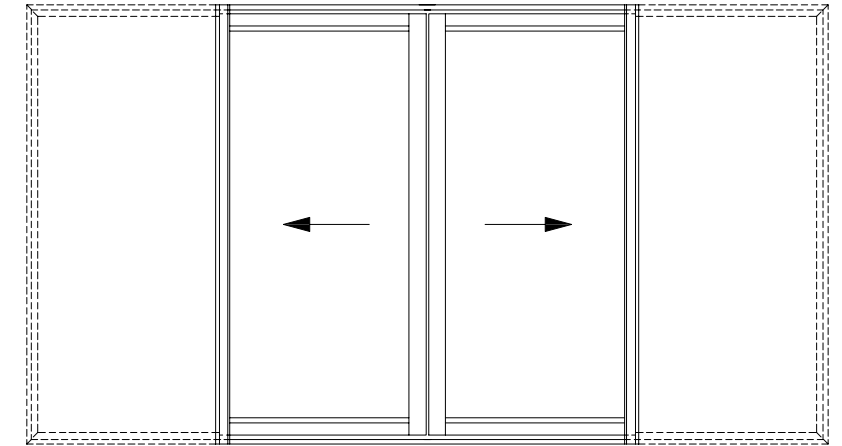

$$B1 = \frac{B2-184}{2}$$

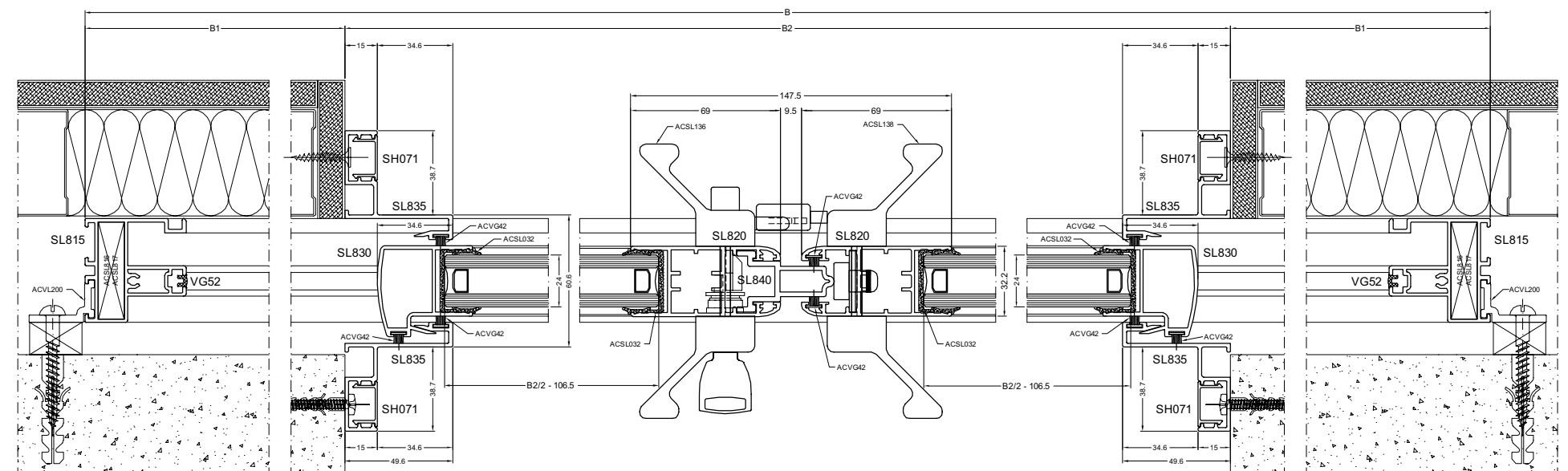

zaag3

2 VLEUGELIG SCHUIFRAAM
FENETRE COULISSANTE DEUX VANTAUX
SCHIEBEFENSTER 2 FLÜGEL
DOUBLE SLIDING WINDOW

ZAAGTABELLEN - TABLES DE SCIAGES - ZUSCHNITT-TABELLEN - SAWING TABLES

PROFIELN PROFILES PROFILE PROFILS

SL815		1		B
SL815		1		H-15
SL815		1		H-15
SL870		1		B
SL820		2		H-47
SL821		4		B2/2 -98,5
SL830		2		H-43
SL835		4		H-34,5
SL840		1		H-110
SH071		4		H-34,5
VG53A		1		B-85
VG52		1		B-85
VG52		2		H-61

TOEBEHOREN ACCESSOIRES
ZUBEHÖRTEILE ACCESSORIES

ACSL810/ACSL811	4
ACSL816/ACSL817	2
ACSL03X	4H+2B2-1500
ACSL021	4
ACSL022	2
ACVG42	8H+4B2-1100
ACSL140	1
ACSL135	1
ACSL136	1
ACSL137	1
ACSL138	1

	ACSL810	ACSL811
Maximaal vleugelgewicht Poids maximum par vantail Maximaal flügelgewicht Max. weight of the vent	80kg	160kg

GLASMATEN DIMENSIONS DES VITRAGES GLASMASSE GLASS SIZES	2X	B2/2 -106.5 H-155
--	----	----------------------

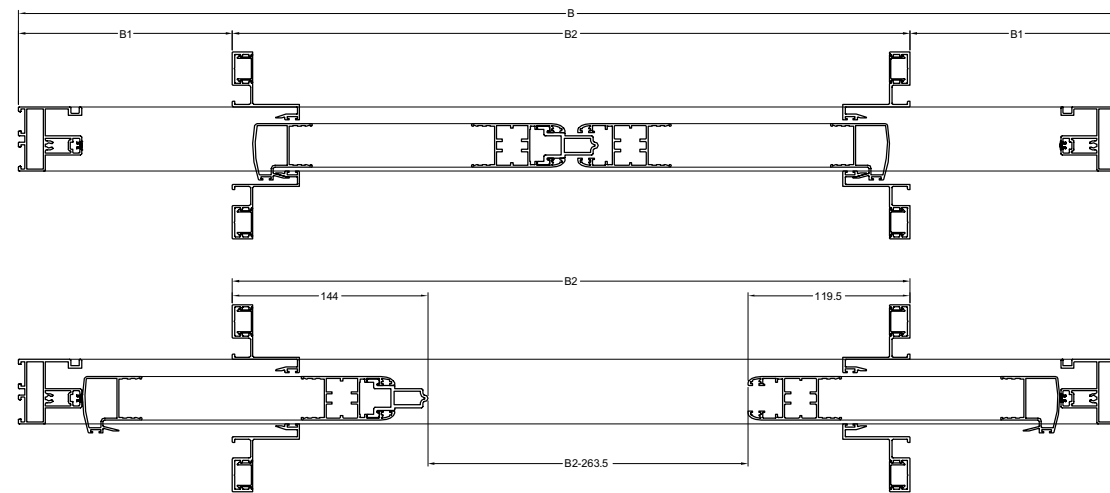
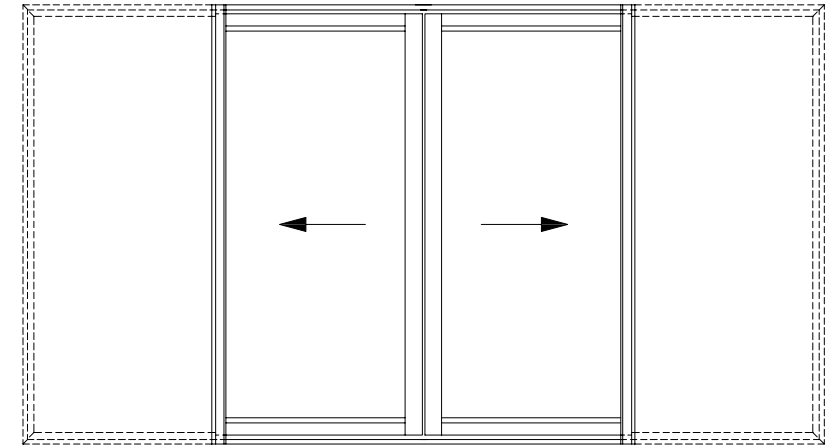
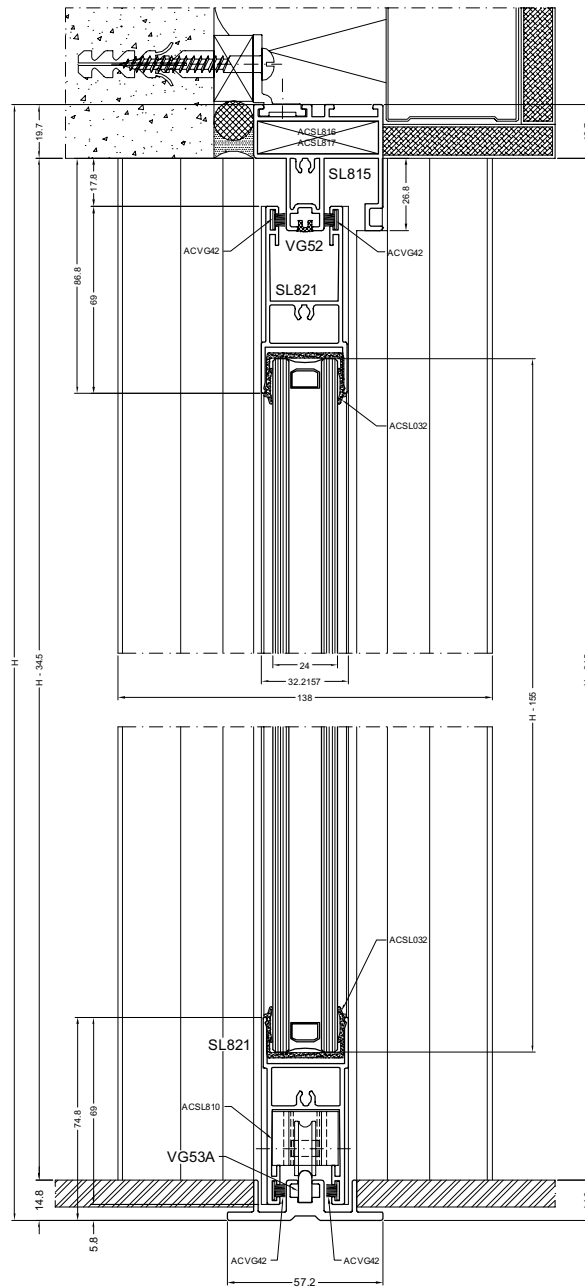

$$B1 = \frac{B2 - 184}{2}$$

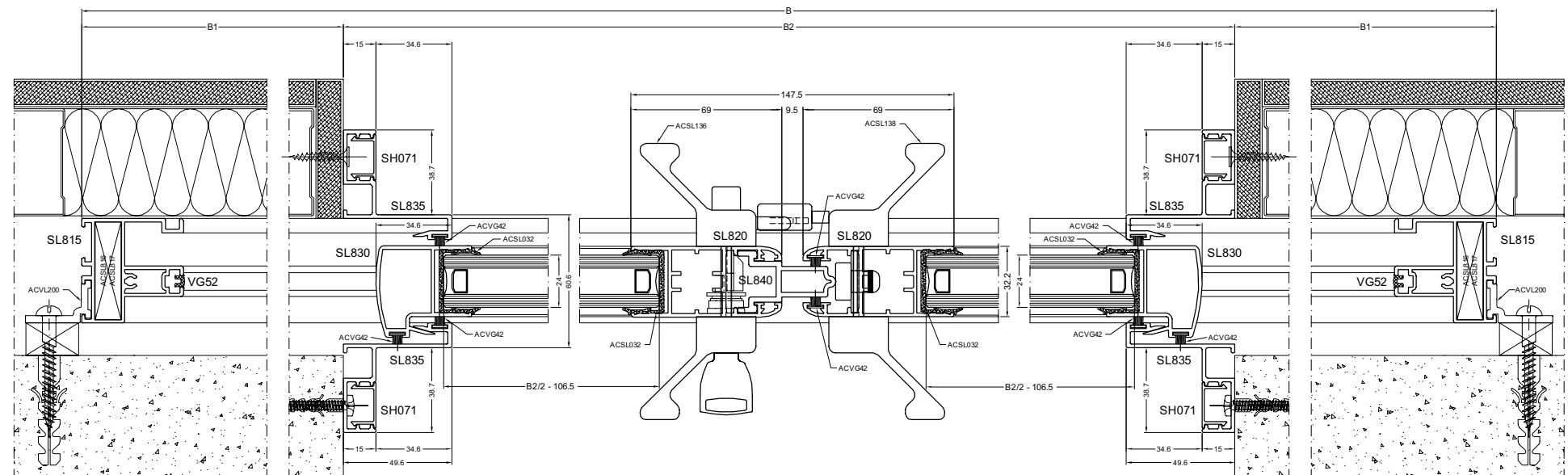

3 VLEUGELIG SCHUIFRAAM
FENETRE COULISSANTE TROIS VANTAUX
SCHIEBEFENSTER 3 FLUGEL
SLIDING WINDOW WITH 3 PANELS

ZAAGTABELLEN - TABLES DE SCIAGES - ZUSCHNITT-TABELLEN - SAWING TABLES

PROFIELEN PROFILES PROFILE PROFILS

SL8311		2		B
SL8311		2		H
SL820		2		H-86
SL821		6		B/3-68
SL830		4		H-82
VG52		3		B-92
VG52		6		H-104
VG53A		3		B-92

TOEBEHOREN ACCESSOIRES
ZUBEHORTEILE ACCESSORIES

ACSL810/ACSL811	6
ACSL814/ACSL815	4
ACSL020	8
ACSL030	2
ACSL03X	6H+2B-1600
ACSL24X	2
ACSL246	2
ACSL021	4
ACSL022	4
ACSL035	2
ACVG42	8H+4B-1500
ACSL024	2

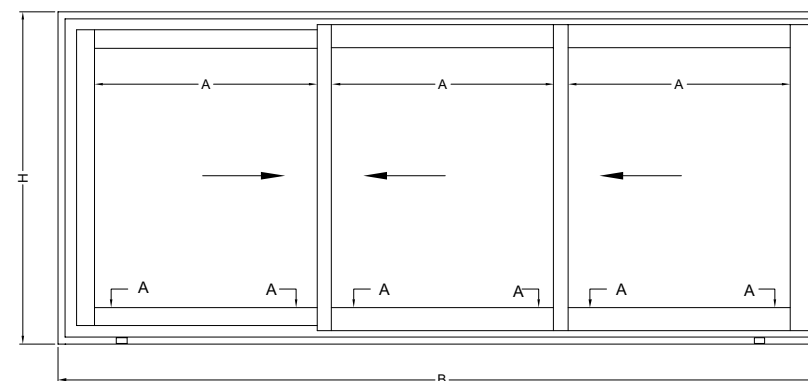

C AFDEKKAPJE WATERAFVOER
CAPUCHON ECOULEMENT D'EAU
ABDECKKAPPE ENTWASSERUNG
DRAIN HOLE COVER

GLASMATEN
DIMENSIONS DES VITRAGES 3X B/3-77
GLASMASSE H-194
GLASS SIZES

B SLEUF 25x7
RAINURE
SCHLITZ
SLOT

A GLASSPONNING ONTLUCHTING 12 x Ø8
VENTILATION FEUILLURE
LUFTUNG ANSCHLAG
VENTILATION GROOVE

	ACSL810	ACSL811
Maximaal vleugelgewicht Poids maximum par vantail Maximaal flügelgewicht Max. weight of the vent	80kg	160kg

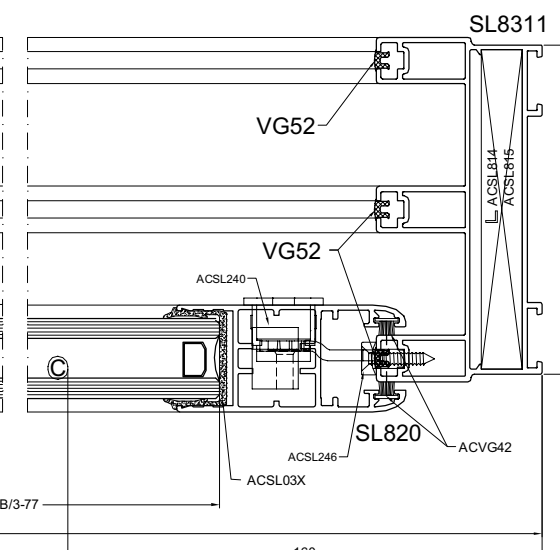
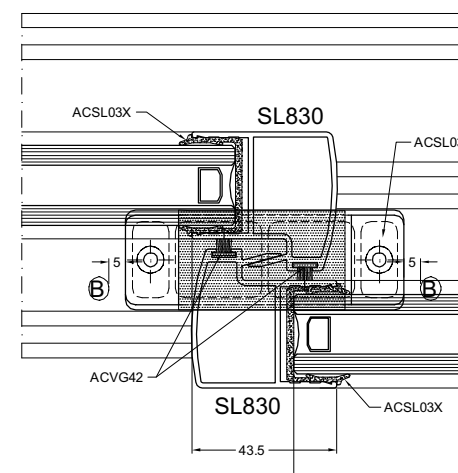
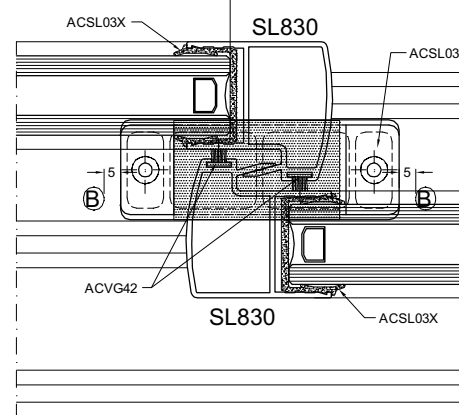
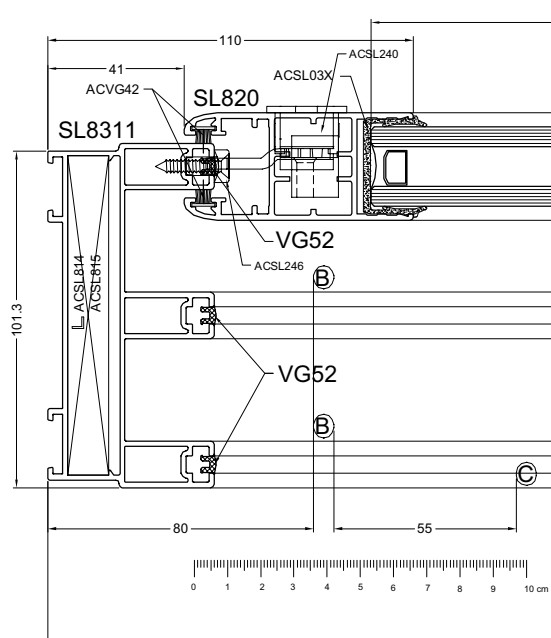
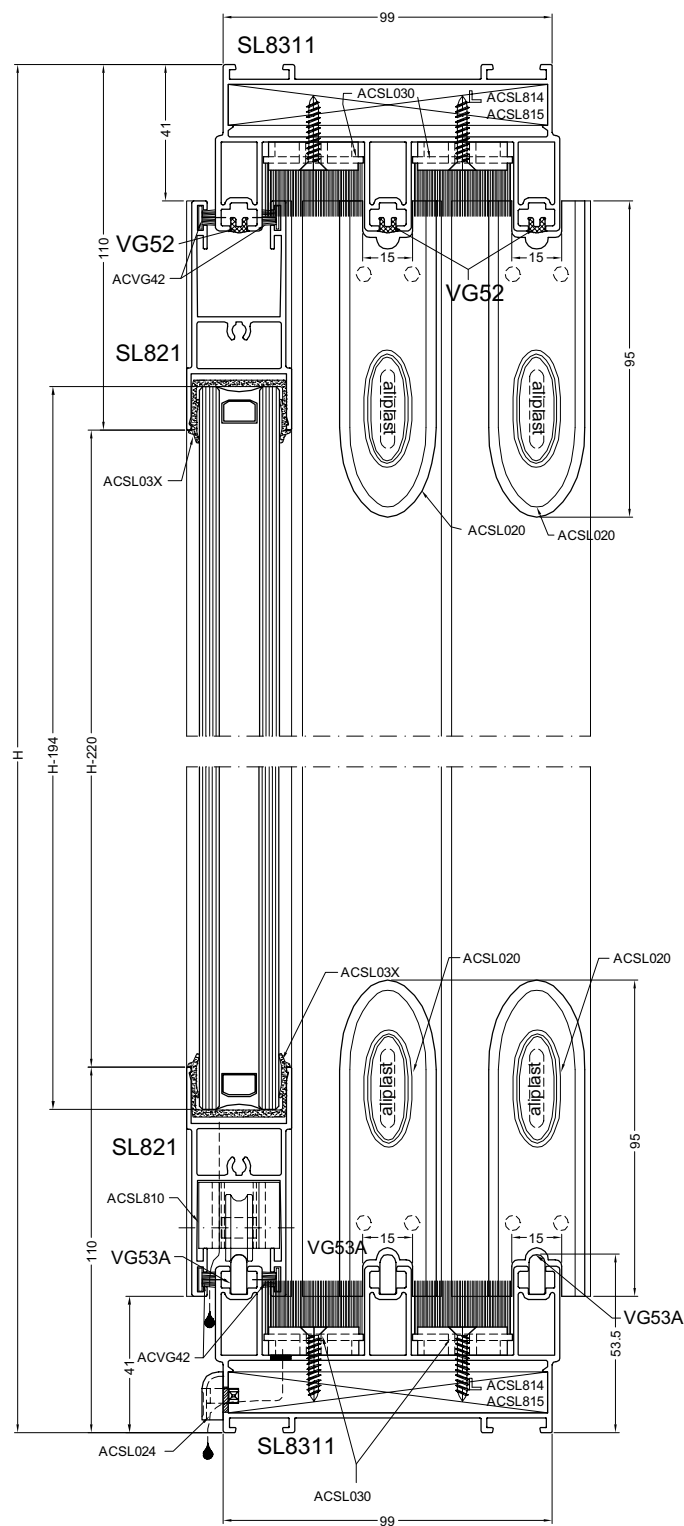

4 VLEUGELIG SCHUIFRAAM
FENETRE COULISSANTE QUATRE VANTAUX
SCHIEBEFENSTER 4 FLUGEL
SLIDING WINDOW WITH 4 PANELS

ZAAGTABELLEN - TABLES DE SCIAGES - ZUSCHNITT-TABELLEN - SAWING TABLES

PROFIELEN PROFILES PROFILE PROFILS

SL810		2		B
SL810		2		H
SL820		4		H-86
SL821		8		B/4-80
SL830		4		H-82
SL840		1		H-149

TOEBEHOREN ACCESSOIRES
ZUBEHÖRTEILE ACCESSORIES

ACSL810/ACSL811	8
ACSL812A/813A	4
ACSL020	8
ACSL030	2
ACSL03X	8H+2B-2200
ACSL24X	2
ACSL248	2
ACSL021	8
ACSL022	6
ACSL035	3
ACVG42	10H+4B-2100
ACSL024	4
ACSL140	1
ACSL134	1
ACSL135	1
ACSL136	1
ACSL137	1
ACSL138	1

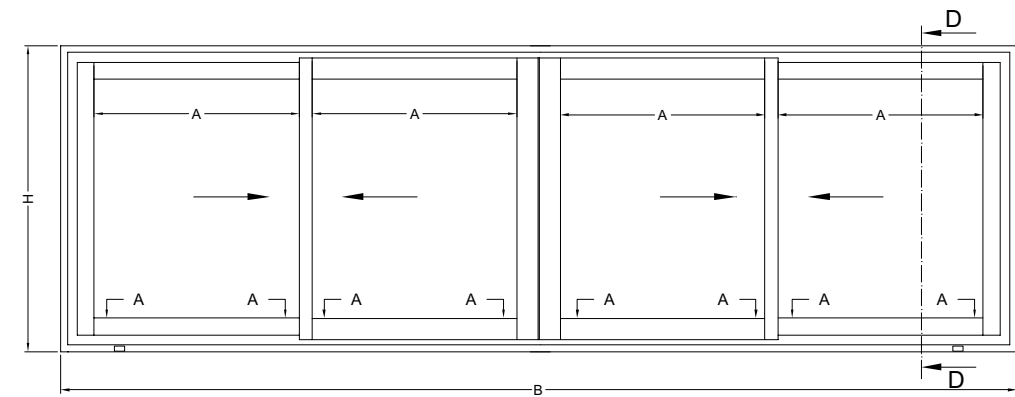

C AFDEKKAPJE WATERAFVOER
CAPUCHON ECOULEMENT D'EAU
ABDECKKAPPE ENTWASSERUNG
DRAIN HOLE COVER

GLASMATEN DIMENSIONS DES VITRAGES GLASSMASSE GLASS SIZES	4X	B/4-88 H-194
---	----	-----------------

A GLASSPONNING ONTLUCHTING 16 x Ø8
VENTILATION FEUILLURE
LUFTUNG ANSCHLAG
VENTILATION GROOVE

B SLEUF 25x7
RAINURE
SCHLITZ
SLOT

	ACSL810	ACSL811
Maximaal vleugelgewicht Poids maximum par vantail Maximaal flügelgewicht Max. weight of the vent	80kg	160kg

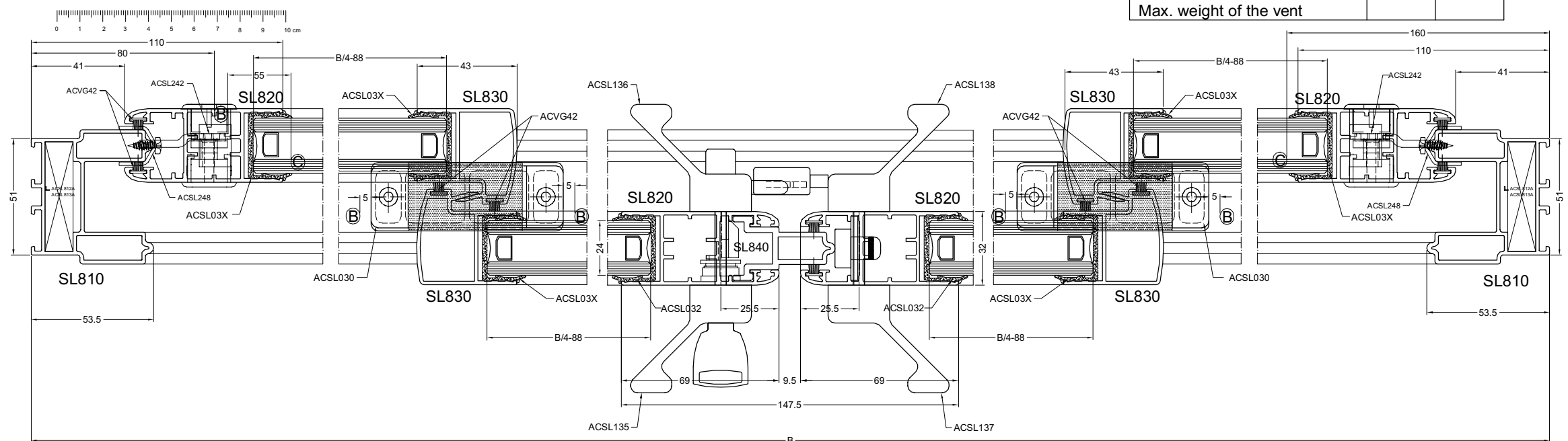
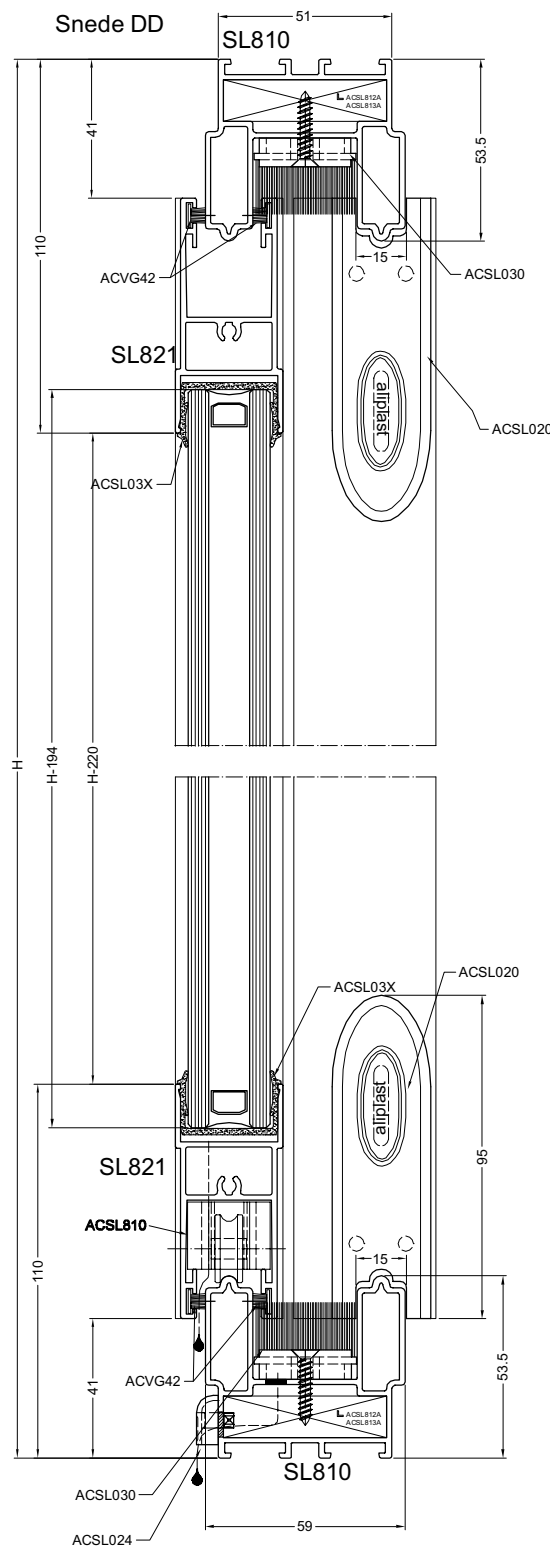

zaagsl3

6 VLEUGELIG SCHUIFRAAM
FENETRE COULISSANTE SIX VANTAUX
SCHIEBEFENSTER 6 FLUGEL
SLIDING WINDOW WITH 6 PANELS

ZAAGTABELLEN - TABLES DE SCIAGES - ZUSCHNITT-TABELLEN - SAWING TABLES

PROFIELEN PROFILES PROFILE PROFILS

SL8311		2		B
SL8311		2		H
SL820		4		H-86
SL821		12		B/6-56
SL830		8		H-82
VG52		3		B-92
VG52		6		H-104
VG53A		3		B-92
SL840		1		H-149

TOEBEHOREN ACCESSOIRES
ZUBEHÖRTEILE ACCESSORIES

ACSL810/ACSL811	12
ACSL814/ACSL815	4
ACSL020	16
ACSL030	4
ACSL03X	12H+2B-3000
ACSL24X	2
ACSL246	2
ACSL021	8
ACSL022	4
ACSL035	3
ACVG42	14H+4B-2500
ACSL024	3
ACSL134	1
ACSL135	1
ACSL136	1
ACSL137	1
ACSL138	1

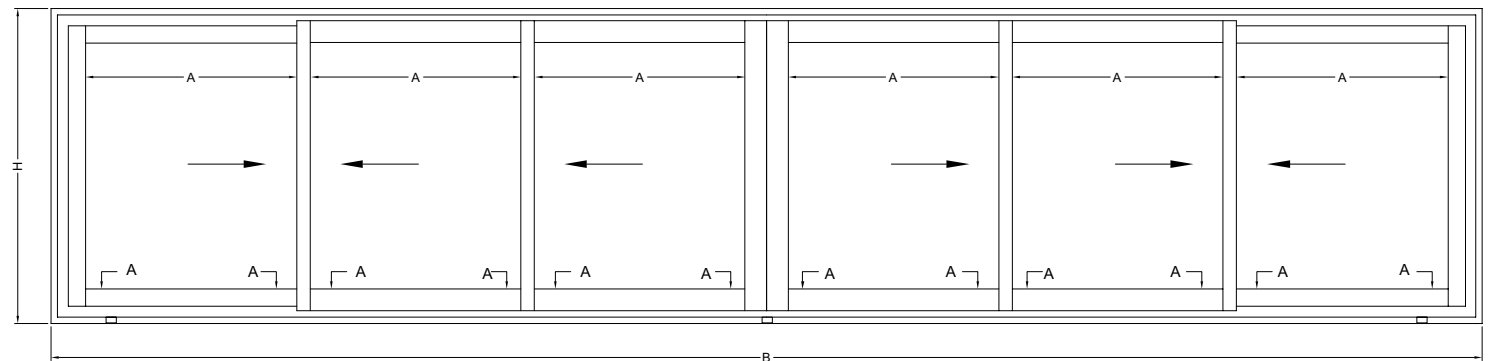

C AFDEKKAPJE WATERAFVOER
CAPUCHON ECOULEMENT D'EAU
ABDECKKAPPE ENTWASSERUNG
DRAIN HOLE COVER

GLASMATEN
DIMENSIONS DES VITRAGES 6X B/6-65
GLASMASSE H-194
GLASS SIZES

B SLEUF 25x7
RAINURE
SCHLITZ
SLOT

A GLASSPONNING ONTLUCHTING 12 x Ø8
VENTILATION FEUILLURE
LUFTUNG ANSCHLAG
VENTILATION GROOVE

	ACSL810	ACSL811
Maximaal vleugelgewicht Poids maximum par vantail Maximaal flügelgewicht Max. weight of the vent	80kg	160kg

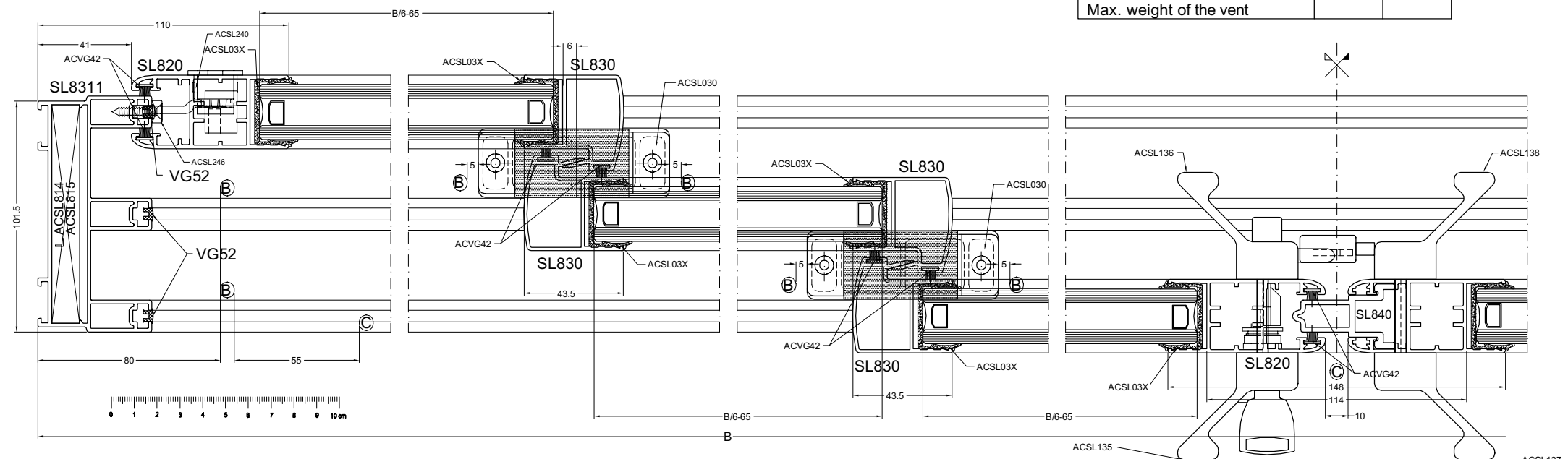
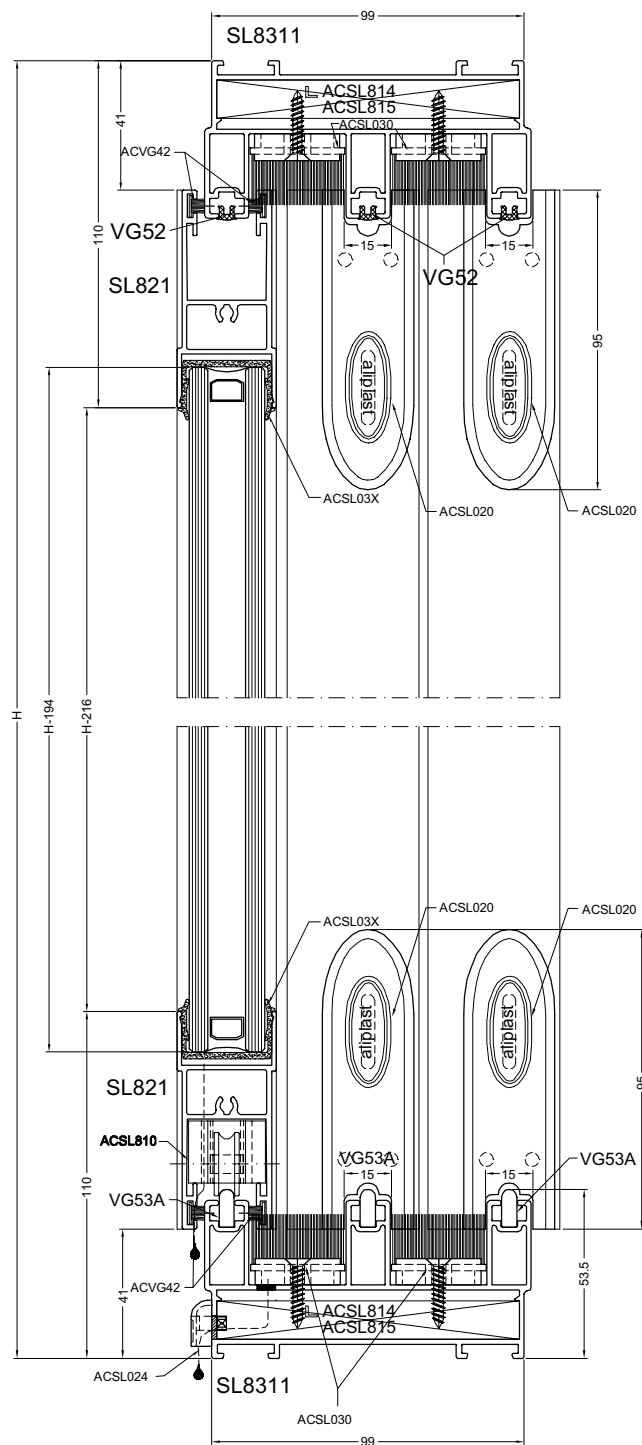

zaagsl5

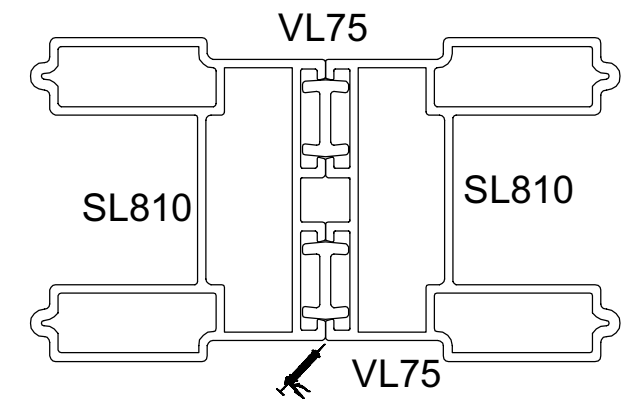
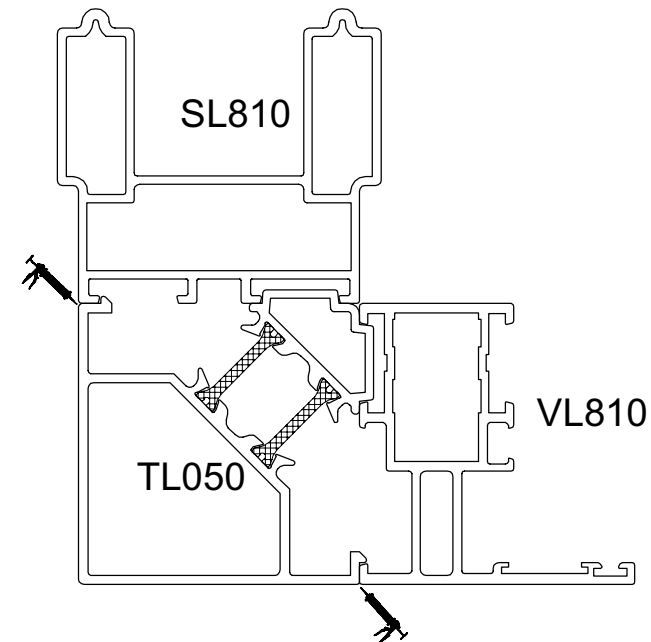
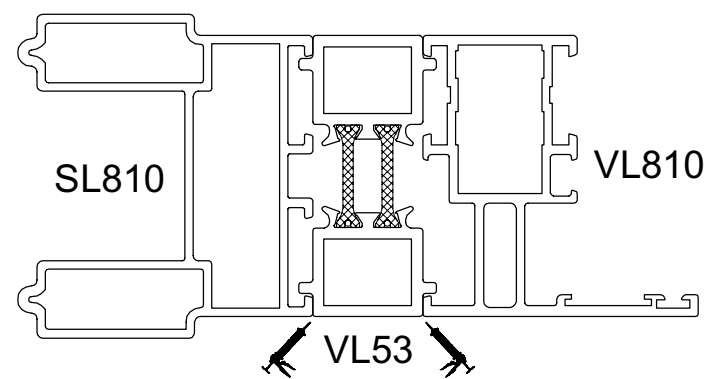
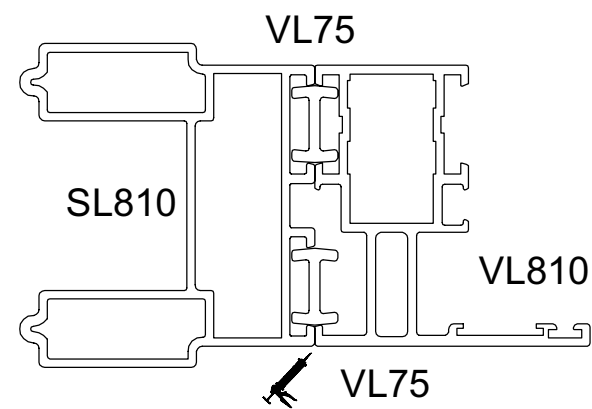
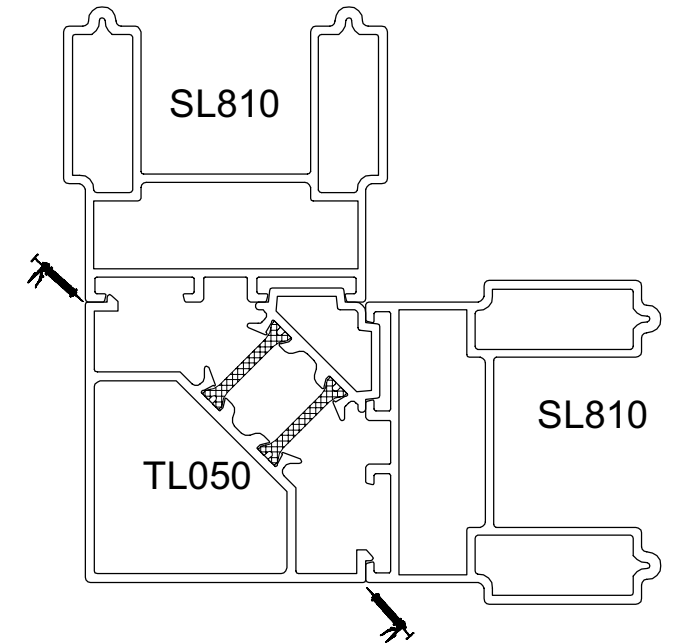
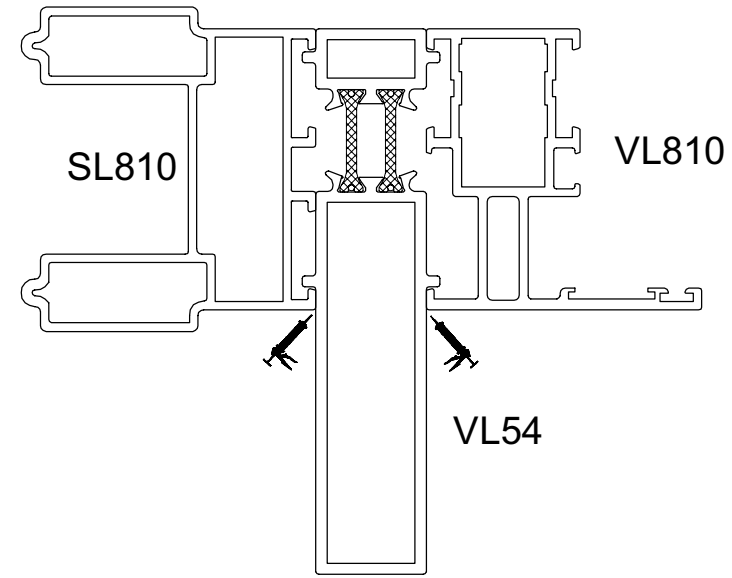
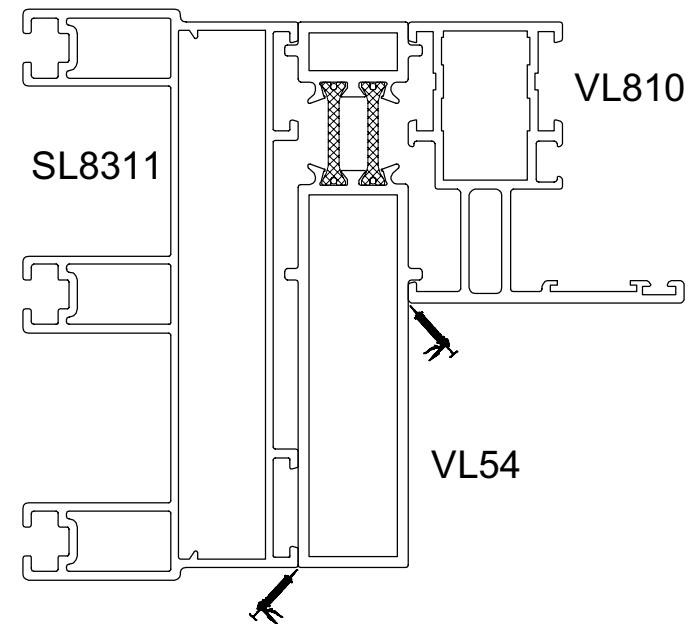
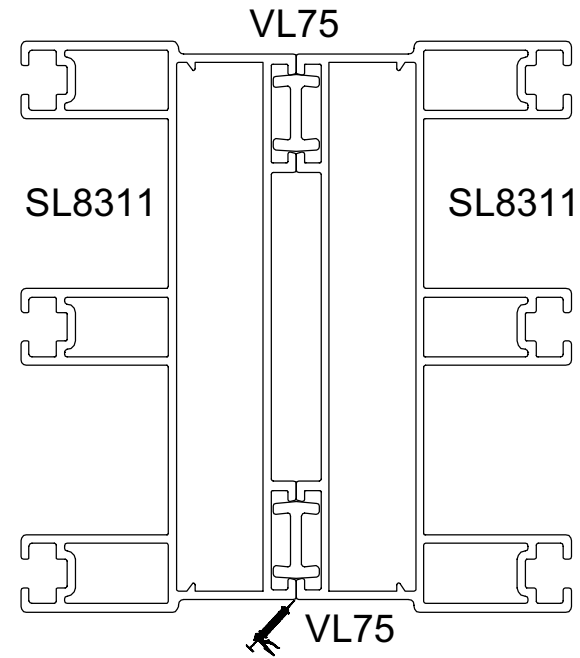

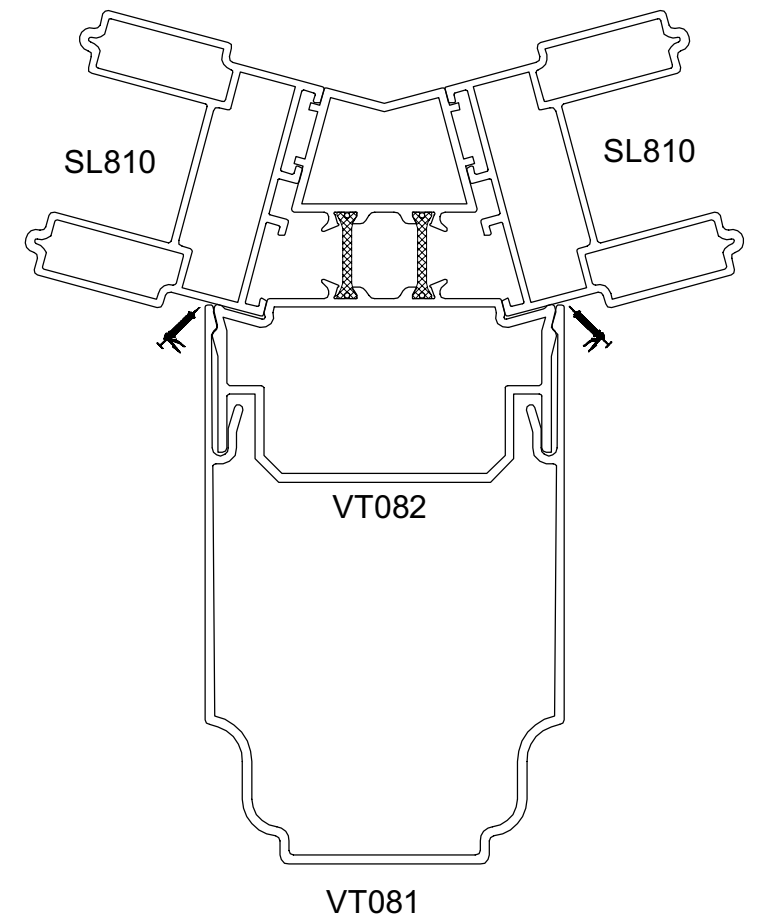
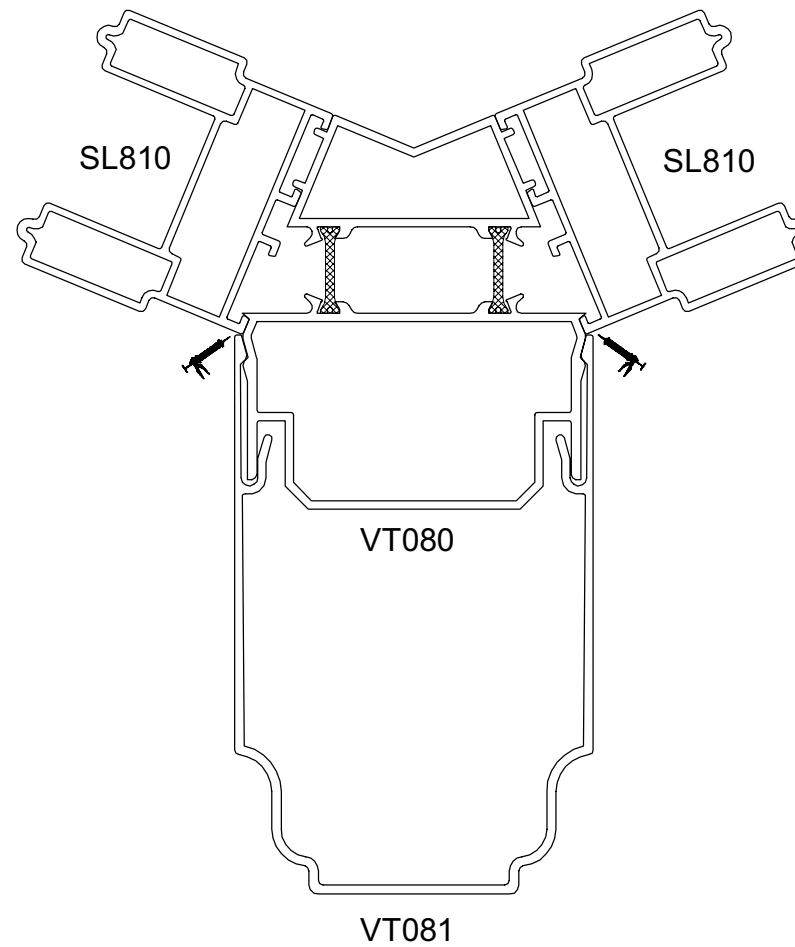
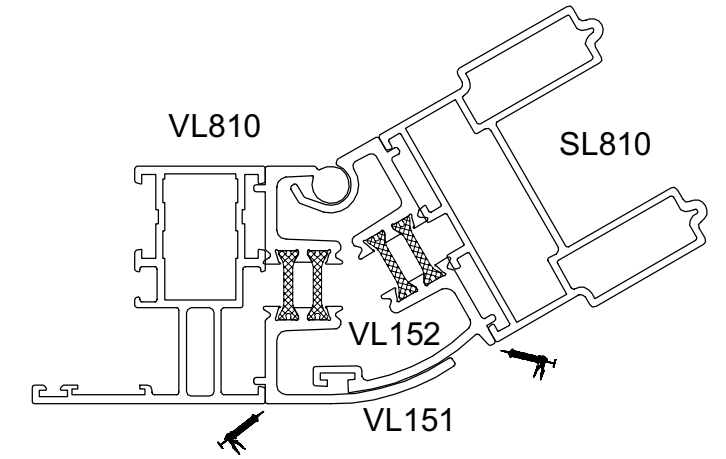
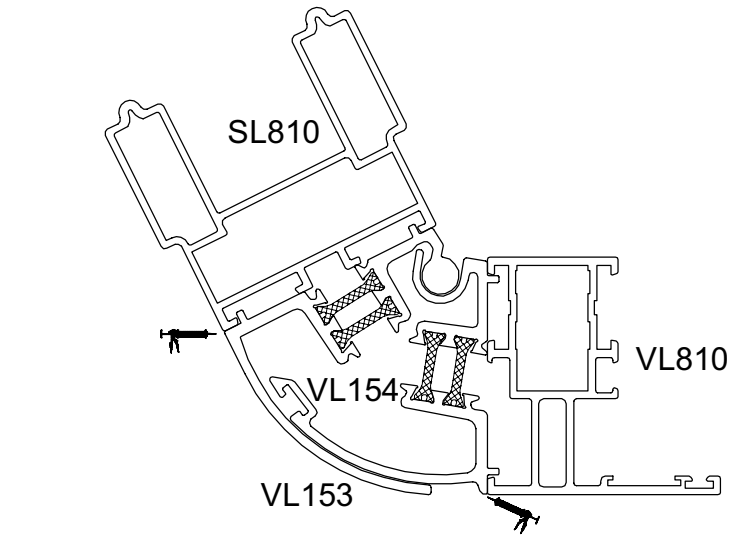
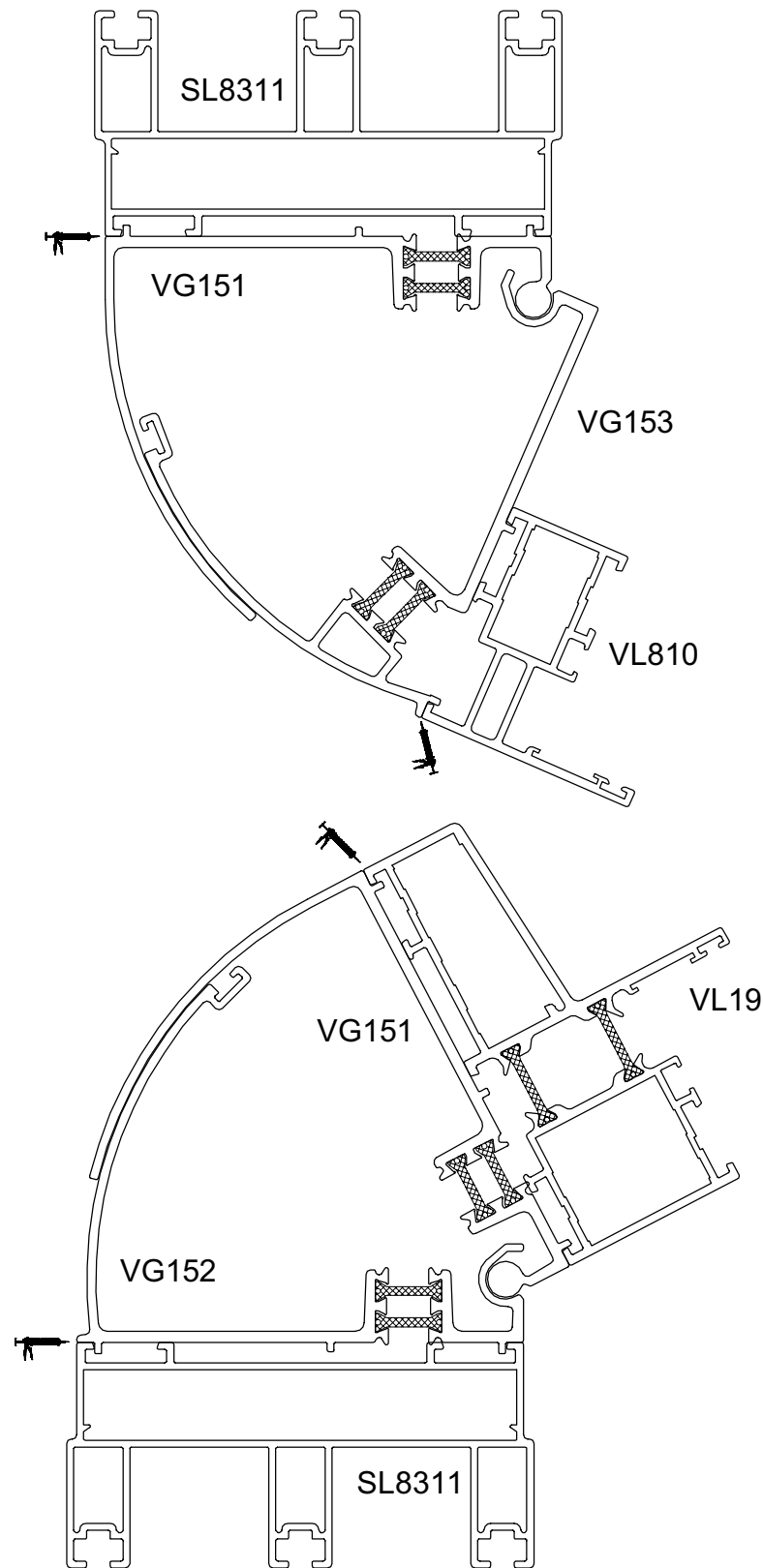

Koppel2

UITSPARING VOOR RAILDOORGANG
ENTAILLE POUR PASSAGE RAIL
EINBAU FÜR GLEISDURCHGANG
ENBEDDING FOR RAILPASSAGE

WERKTEKENINGEN - DESSINS DE CONSTRUCTION - KONSTRUKTIONZEICHNUNGEN - CONSTRUCTION DRAWINGS

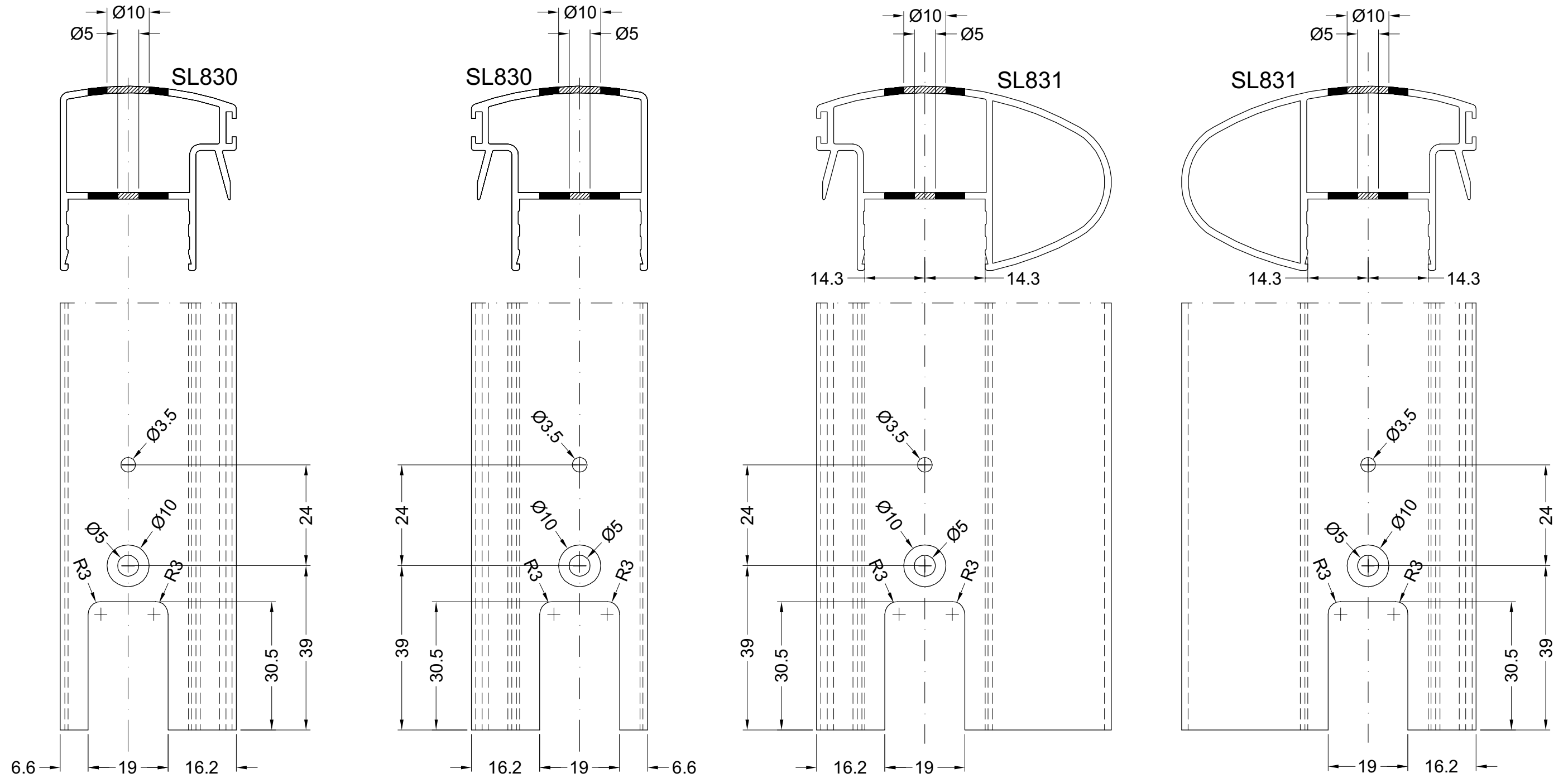

Chicanes

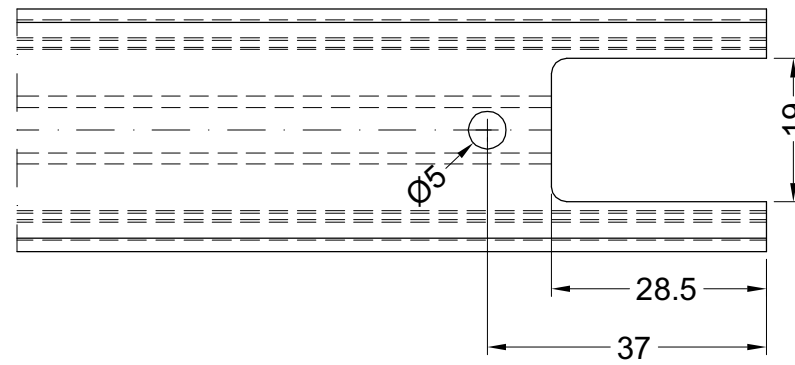
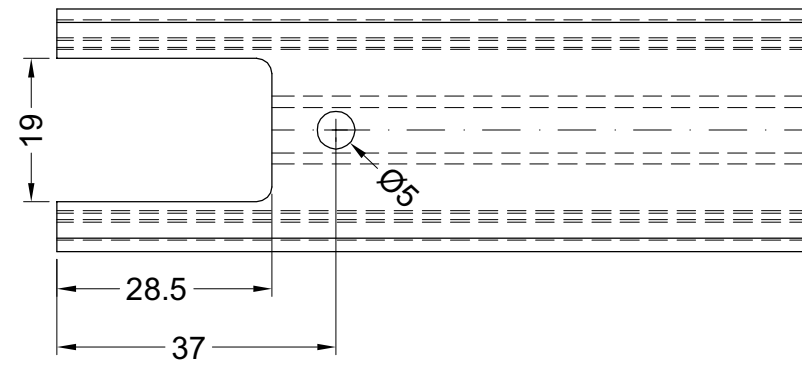

SL820

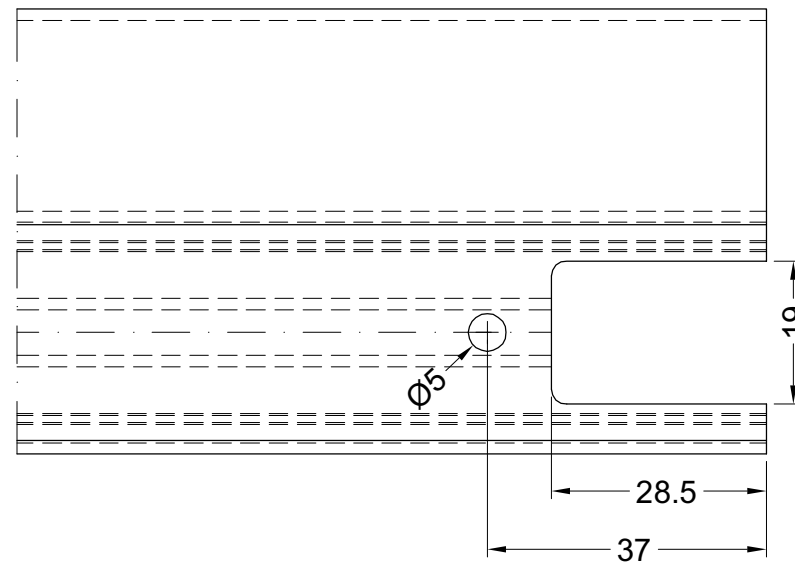
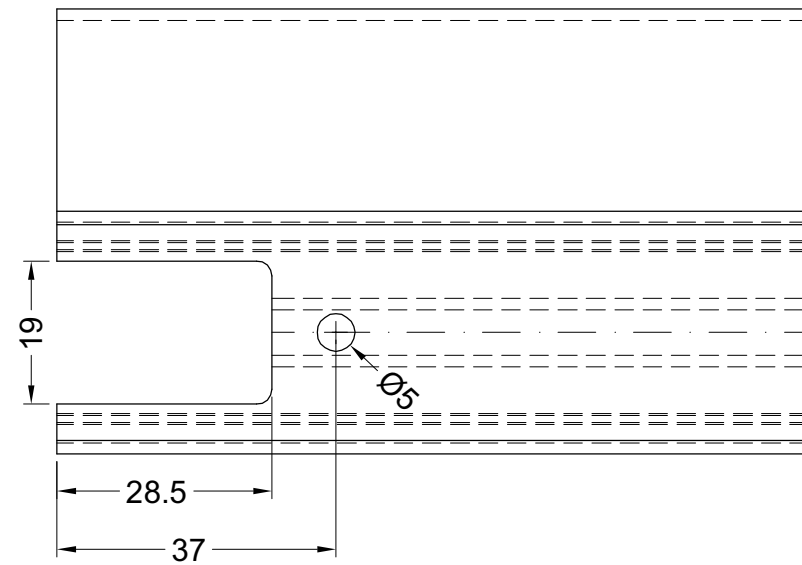
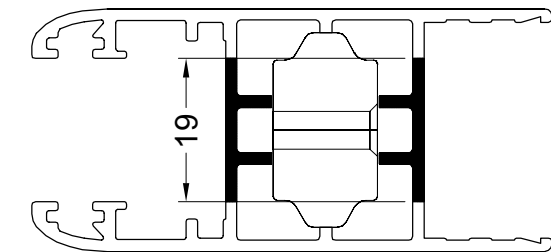

SL8120

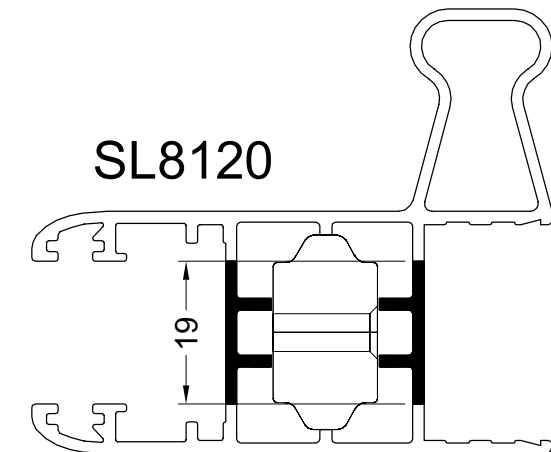

UITSPARING VOOR RAILDOORGANG
ENTAILLE POUR PASSAGE RAIL
EINBAU FÜR GLEISDURCHGANG
ENBEDDING FOR RAILPASSAGE

WERKTEKENINGEN - DESSINS DE CONSTRUCTION - KONSTRUKTIONZEICHNUNGEN - CONSTRUCTION DRAWINGS

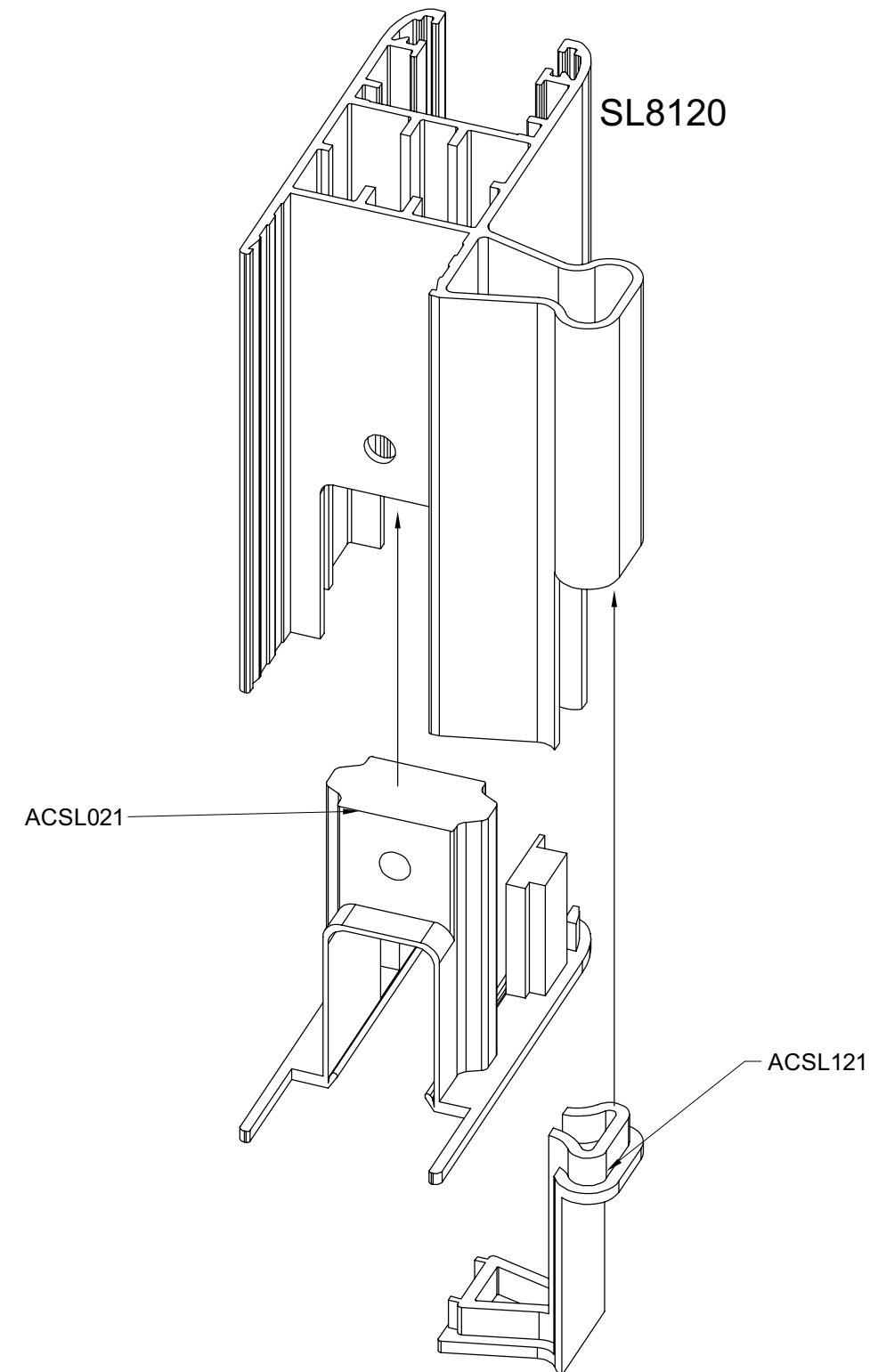
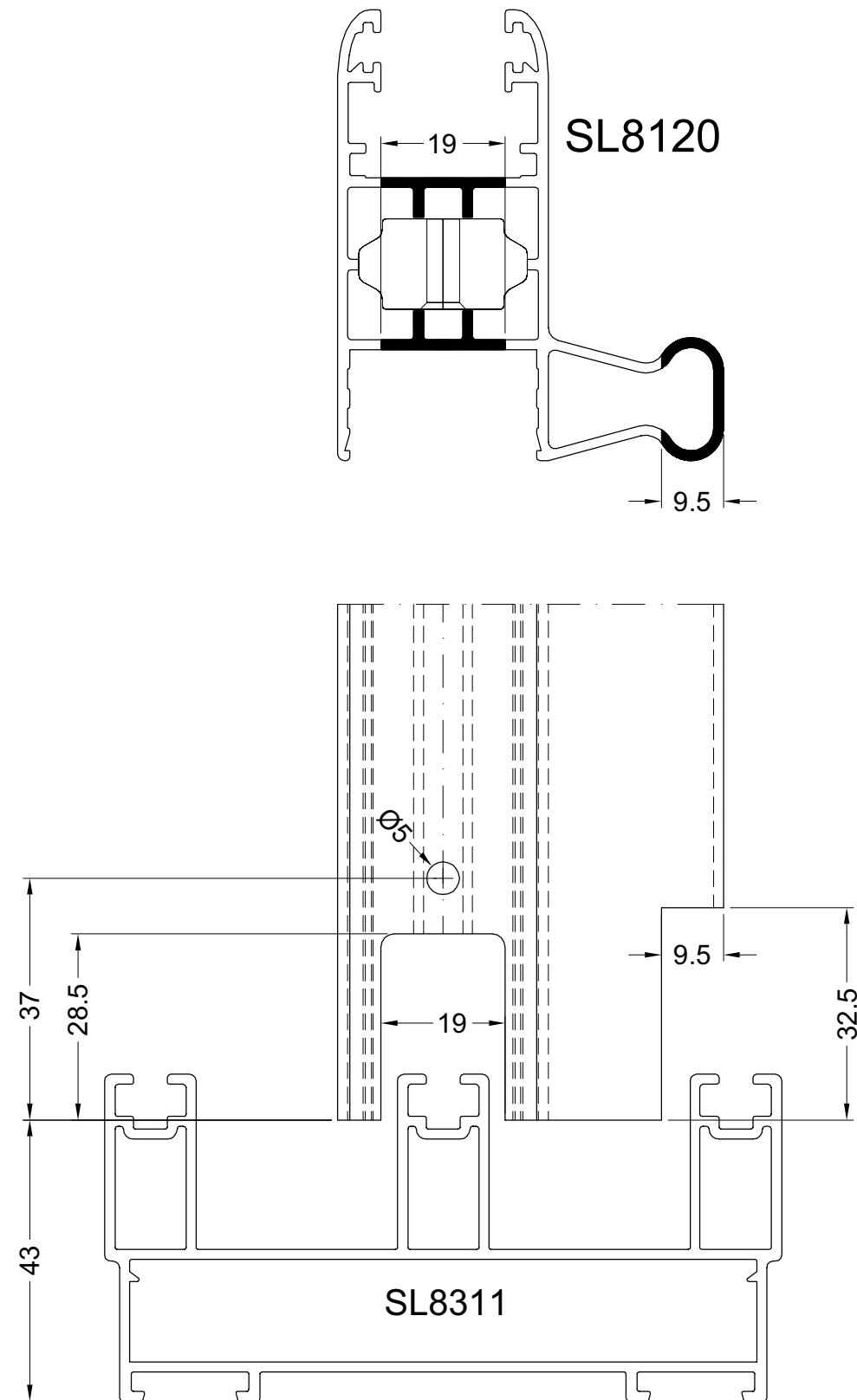

chicane3

UITSPARING VOOR RAILDOORGANG / 3-DELIG
ENTAILLE POUR PASSAGE RAIL / 3 VANTAUX
EINBAU FÜR GLEISDURCHGANG / 3 FLUGEL
ENBEDDING FOR RAILPASSAGE / 3 PANEL

WERKTEKENINGEN - DESSINS DE CONSTRUCTION - KONSTRUKTIONZEICHNUNGEN - CONSTRUCTION DRAWINGS

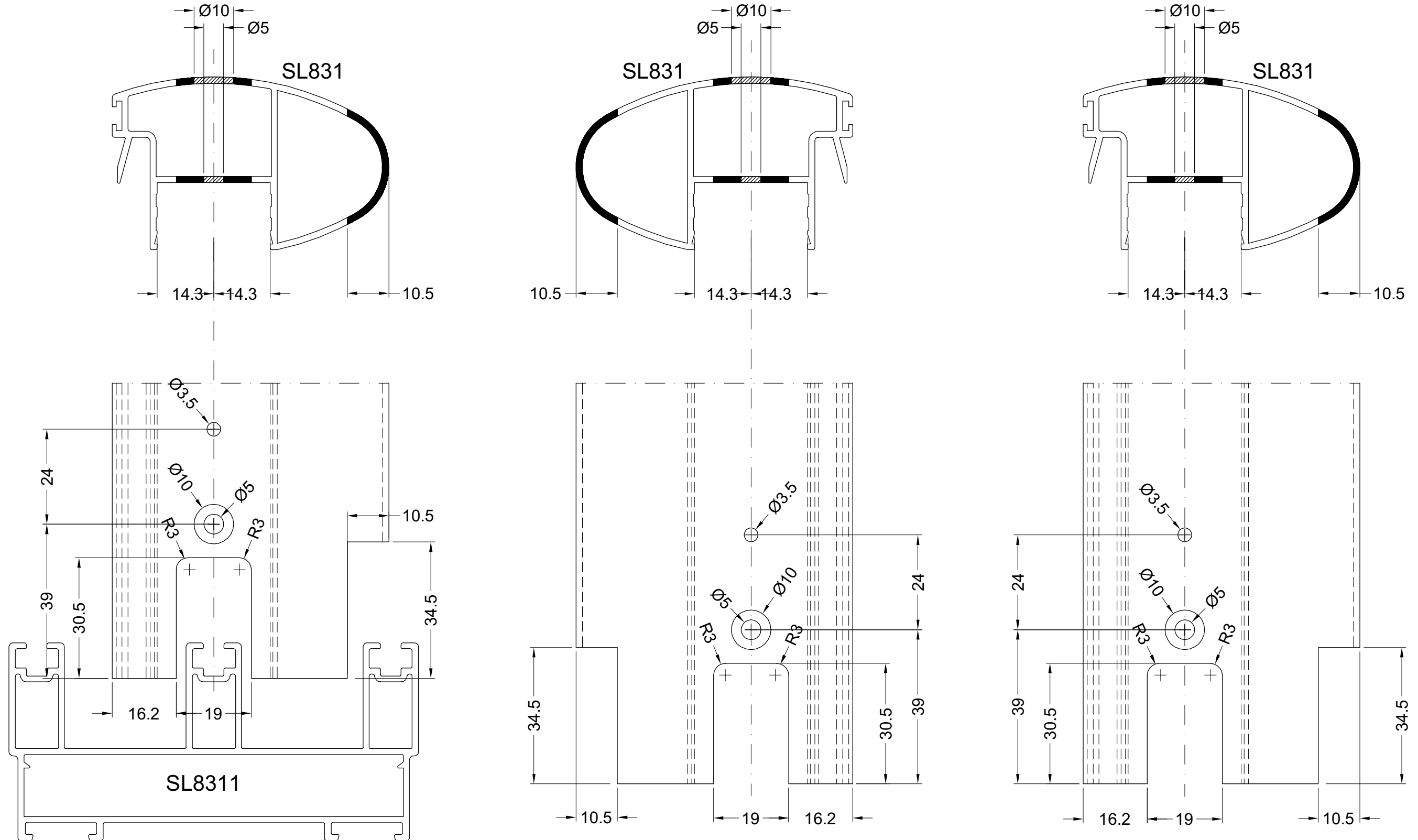

Chican3r

UITSPARING VOOR ACSL010
ENTAILLE POUR ACSL010
EINBAU FÜR ACSL010
ENBEDDING FOR ACSL010

WERKTEKENINGEN - DESSINS DE CONSTRUCTION - KONSTRUKTIONZEICHNUNGEN - CONSTRUCTION DRAWINGS

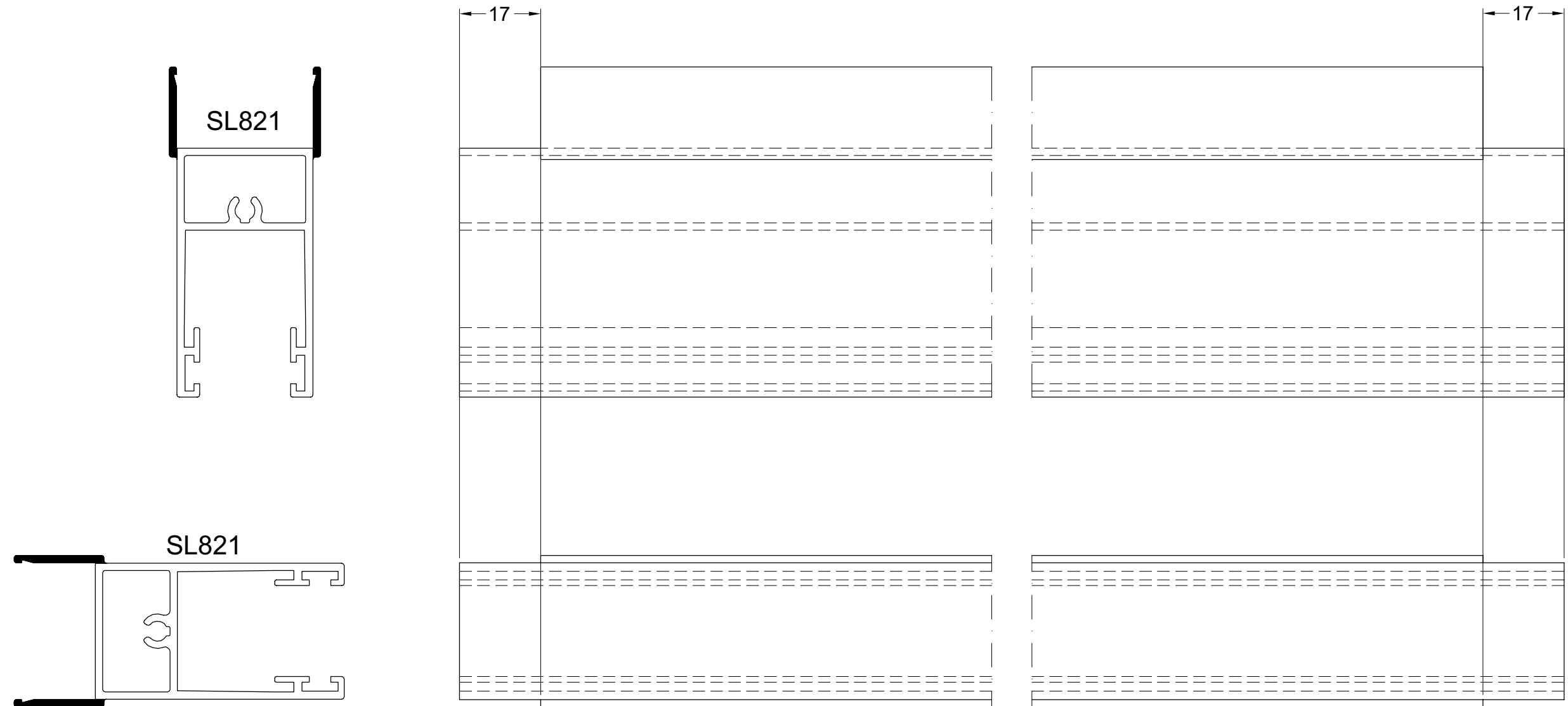

UITSPARING VOOR KOMGREEP
 ENTAILLE POUR CUVETTE
 AUSFRASUNG FÜR GRIFF
 SAVING FOR GRIP

WERKTEKENINGEN - DESSINS DE CONSTRUCTION - KONSTRUKTIONZEICHNUNGEN - CONSTRUCTION DRAWINGS

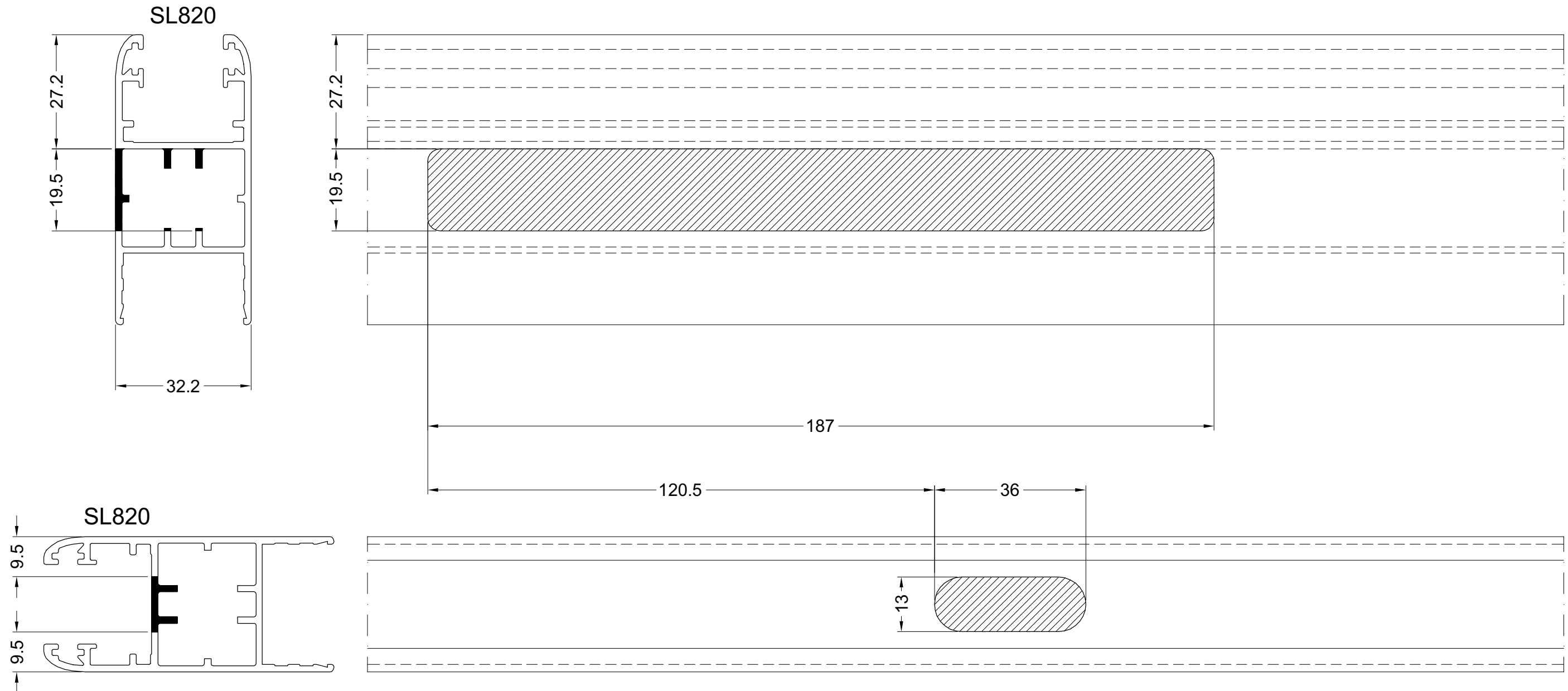

UITSPARING VOOR DUBBELE KOMGREEP
ENTAILLE POUR DOUBLE CUVETTE
AUSFRASUNG FÜR DOPPELT GRIFF
SAVING FOR DOUBLE GRIP

WERKTEKENINGEN - DESSINS DE CONSTRUCTION - KONSTRUKTIONZEICHNUNGEN - CONSTRUCTION DRAWINGS

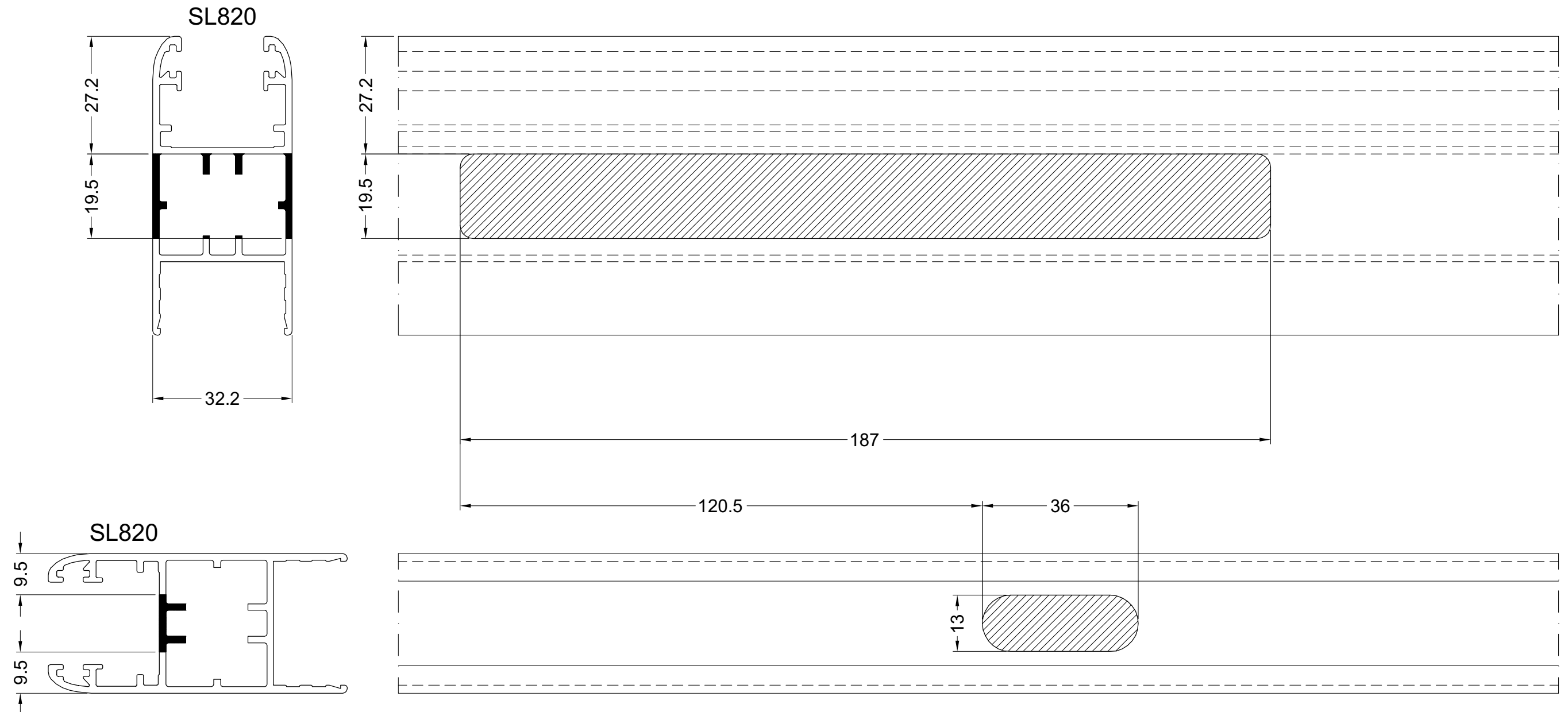

slot2

UITSPARING SL835
ENTAILLE SL835
EINBAU SL835
EMBEDDING SL835

WERKTEKENINGEN - DESSINS DE CONSTRUCTION - KONSTRUKTIONZEICHNUNGEN - CONSTRUCTION DRAWINGS

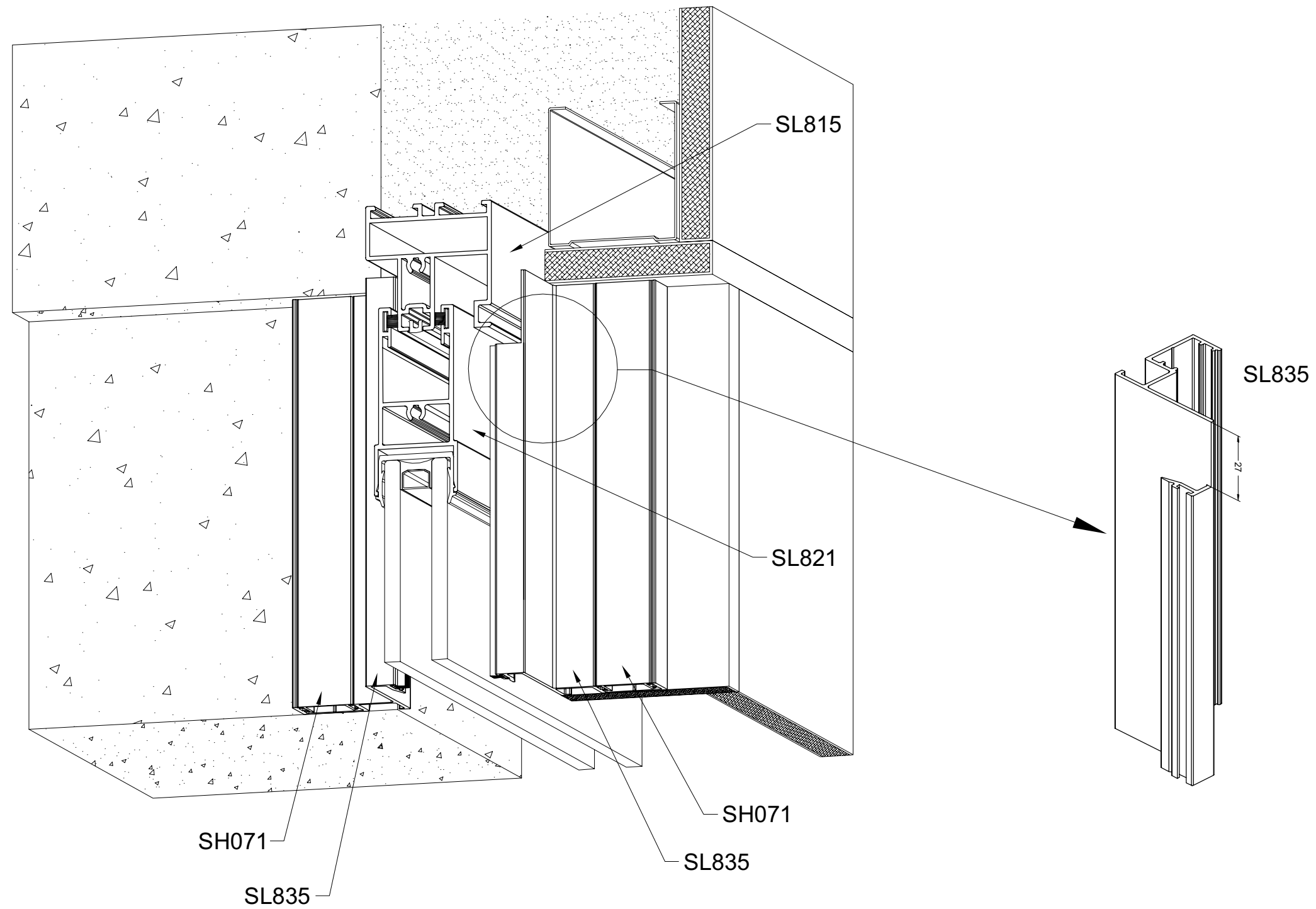

AFWATERING
DRAINAGE
ENTWASSERUNG
DRAINAGE

WERKTEKENINGEN - DESSINS DE CONSTRUCTION - KONSTRUKTIONZEICHNUNGEN - CONSTRUCTION DRAWINGS

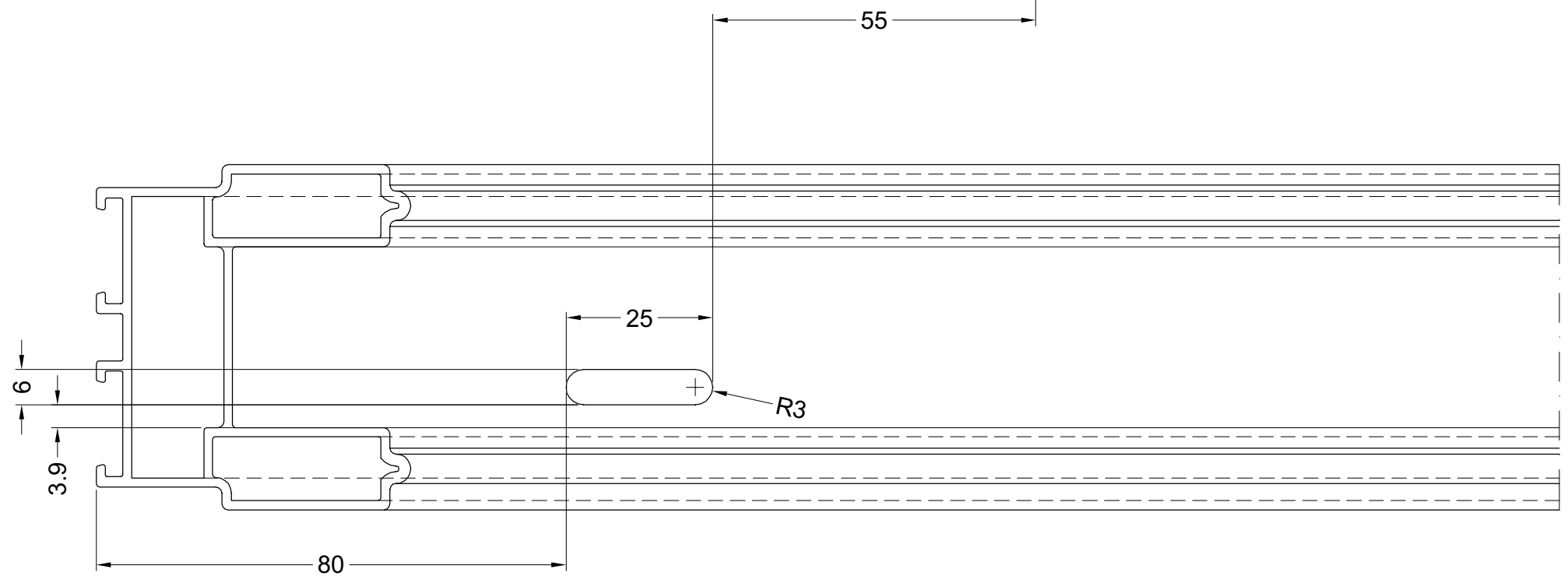
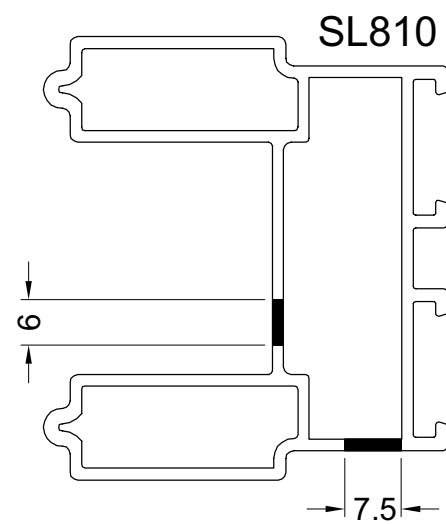
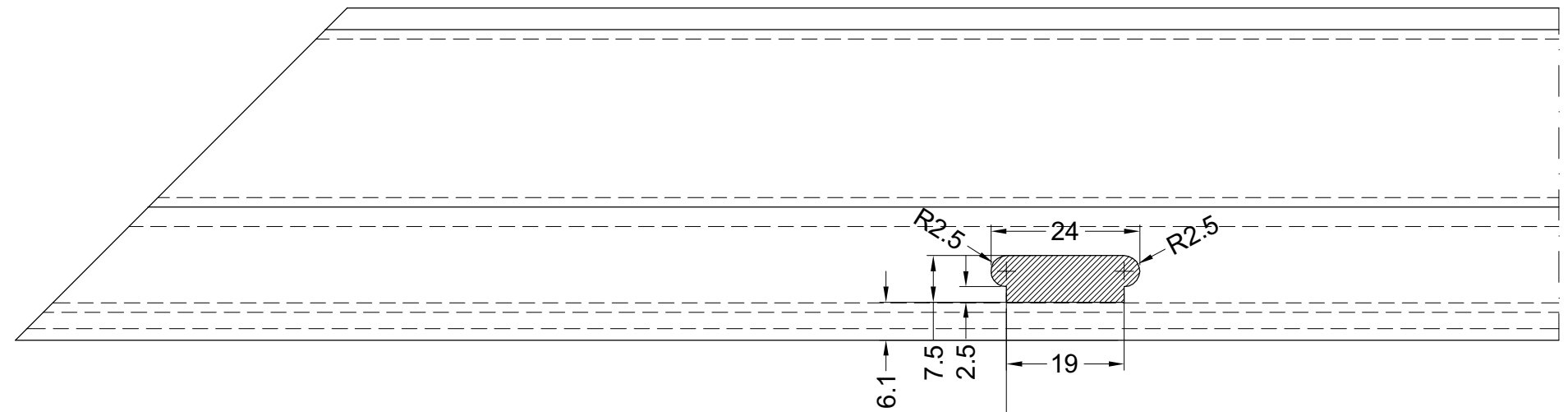
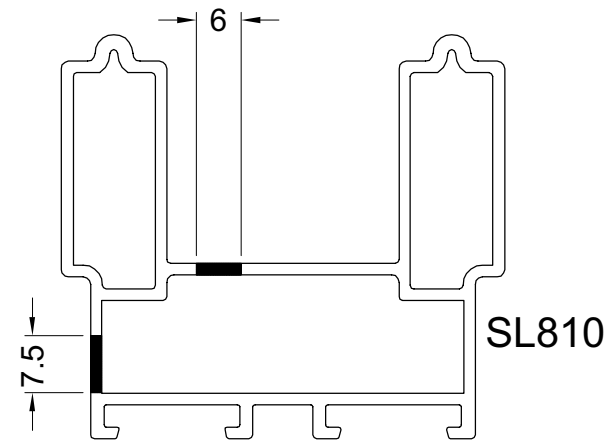

MONTAGE SCHROEFHOEK VOOR SL810
 MONTAGE CLAME A VISSER POUR SL810
 MONTAGE ECKVERBINDER SCHRAUBBAR FÜR SL810
 MONTAGE SQUARE COUPLING JOINT FOR SL810

WERKTEKENINGEN - DESSINS DE CONSTRUCTION - KONSTRUKTIONZEICHNUNGEN - CONSTRUCTION DRAWINGS

1. Ontvetten van zaagsnede
 Degraisser les coupes
 Entfetten der Sageschnitt
 Degrease saw cut
2. Afkitten met ACSIL04
 Colmater avec ACSIL04
 Abdichten mit ACSIL04
 Seal with ACSIL04
3. Lijmen in profiel met ACSIL013 (met pistool ACSIL08)
 Colle ACSIL013 a mettre dans les chambres (pistolet ACSIL08)
 ACSIL013 Klebstoff im Profil (Kleberpistol ACSIL08)
 ACSIL013 glue in profile (pistol ACSIL08)
4. Blokjes vastdraaien met ACVG66
 Serrer les clames avec ACVG66
 Festsetzen der Eckverbinder mit ACVG66
 Fixe the cleat corner with ACVG66

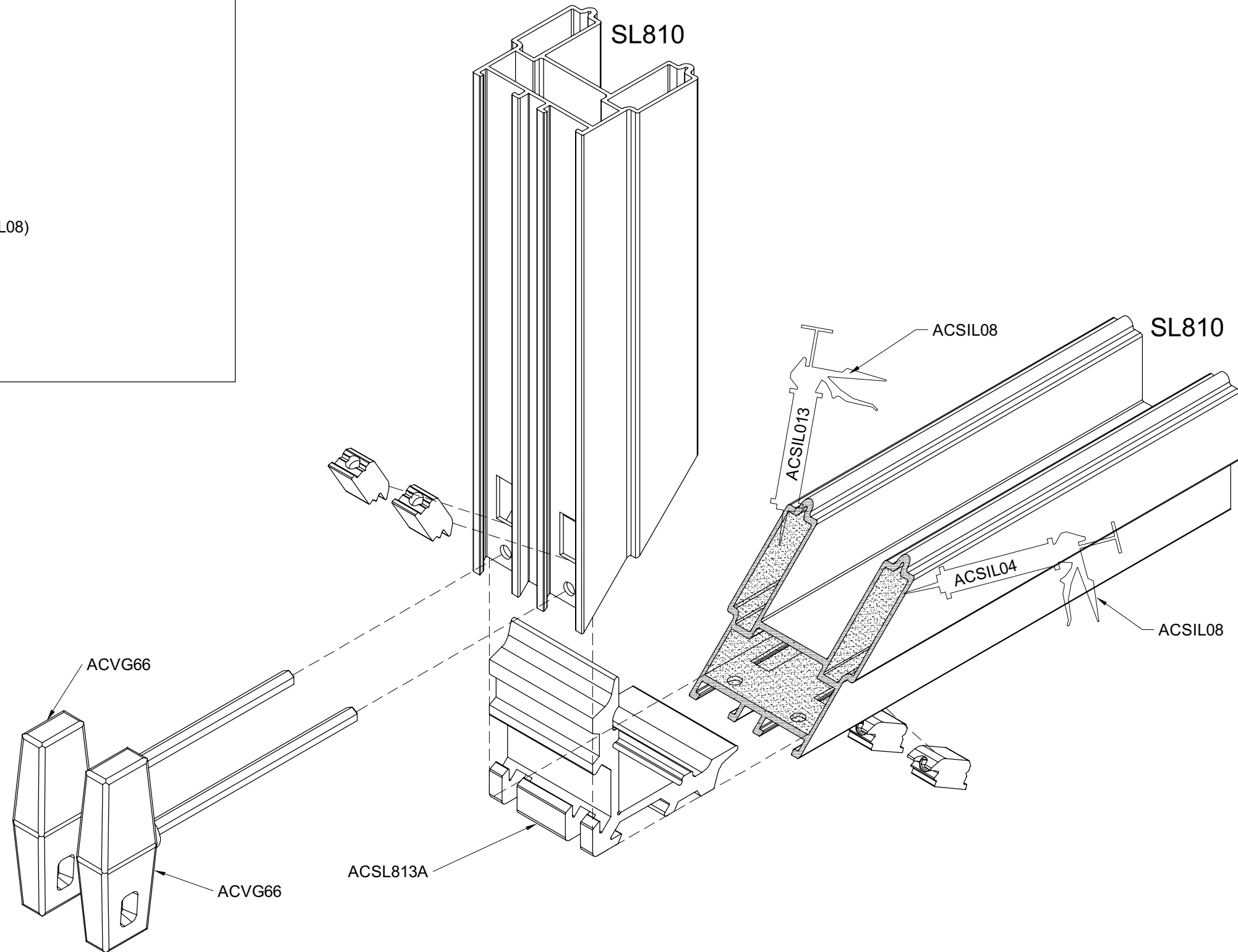
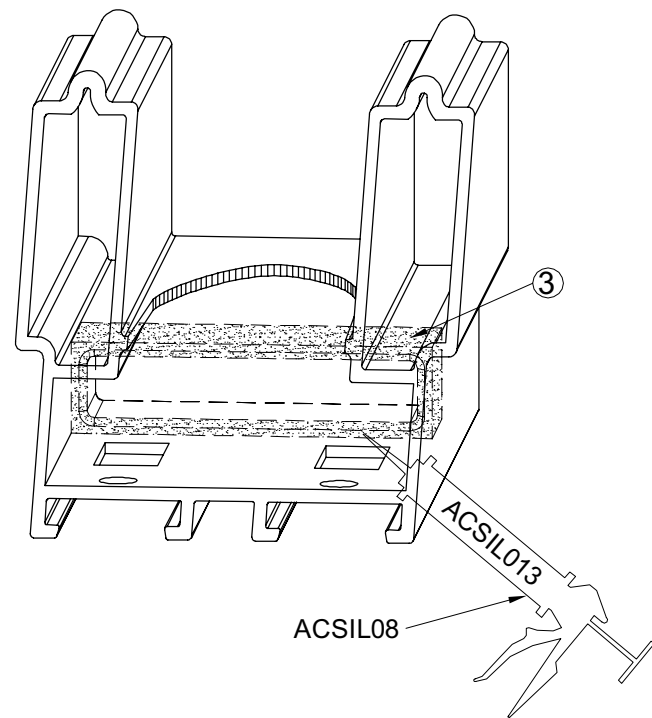

MONTAGE SCHROEFHOEK VOOR SL810
MONTAGE CLAME A VISSER POUR SL810
AUFSTELLEN ECK SCHRAUBBAR FÜR SL810
ASSEMBLY SCREWING CORNER FOR SL810

WERKTEKENINGEN - DESSINS DE CONSTRUCTION - KONSTRUKTIONZEICHNUNGEN - CONSTRUCTION DRAWINGS

COUPE A-A

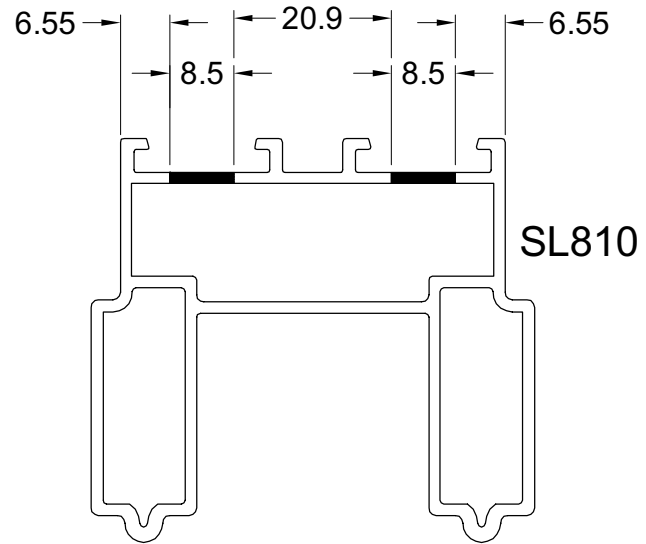
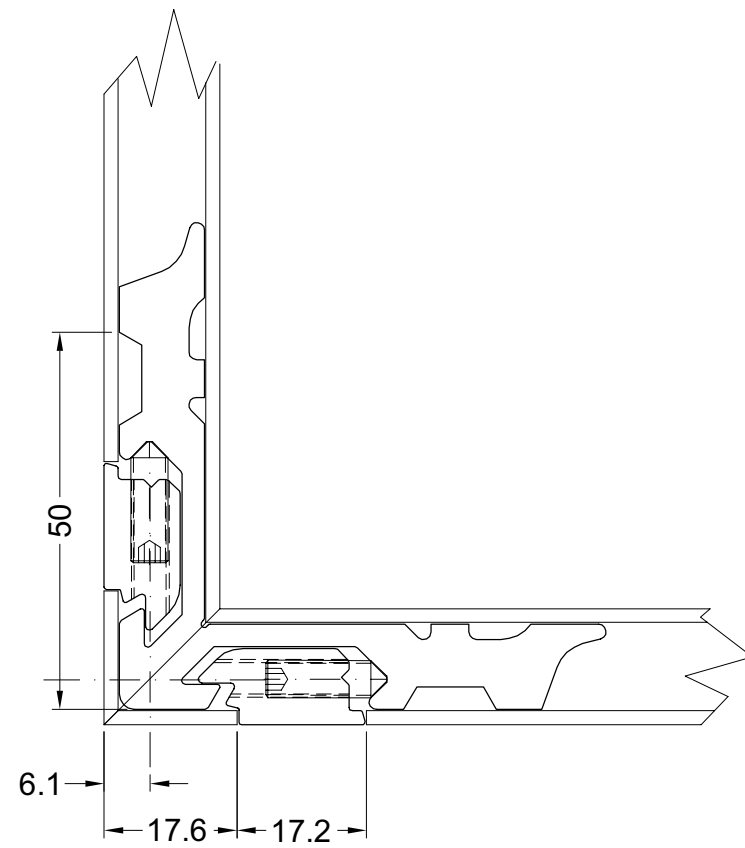

A B

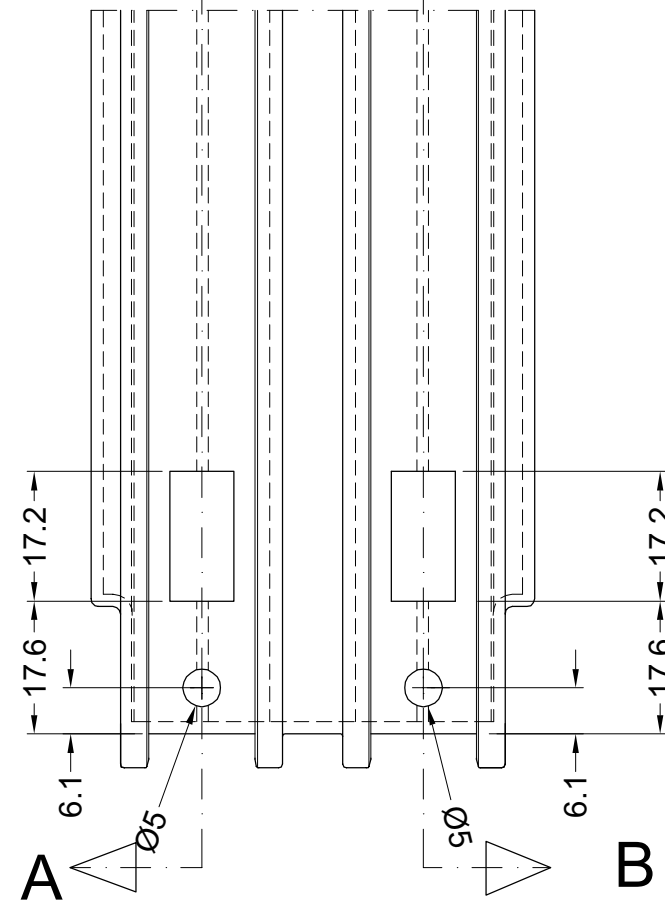

A B

COUPE B-B

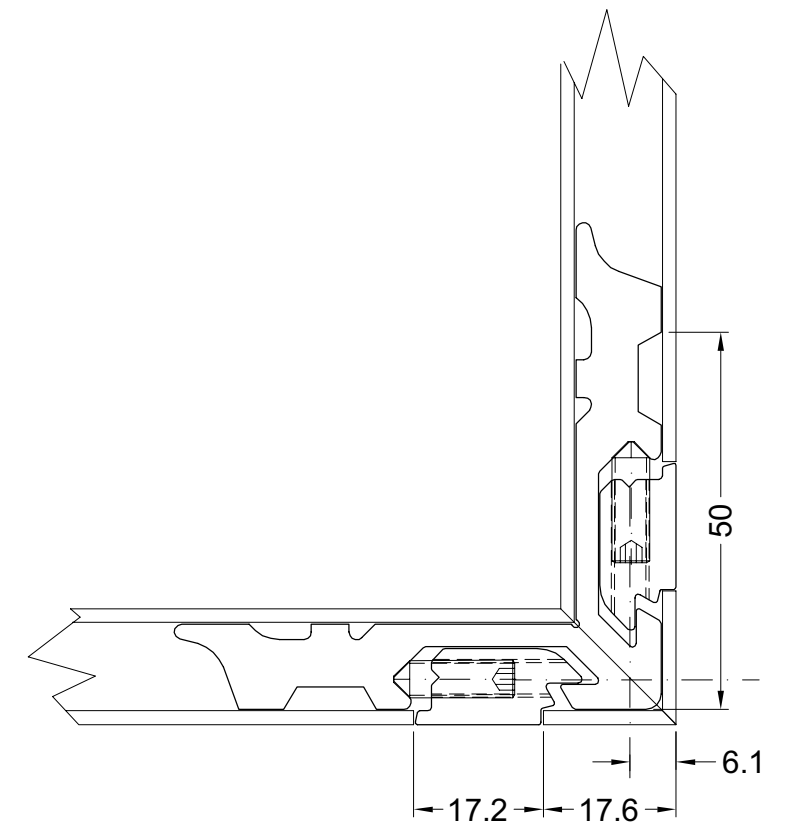

Dormants

MONTAGE ACSL047
MONTAGE ACSL047
AUFSTELLEN ACSL047
ASSEMBLY ACSL047

WERKTEKENINGEN - DESSINS DE CONSTRUCTION - KONSTRUKTIONZEICHNUNGEN - CONSTRUCTION DRAWINGS

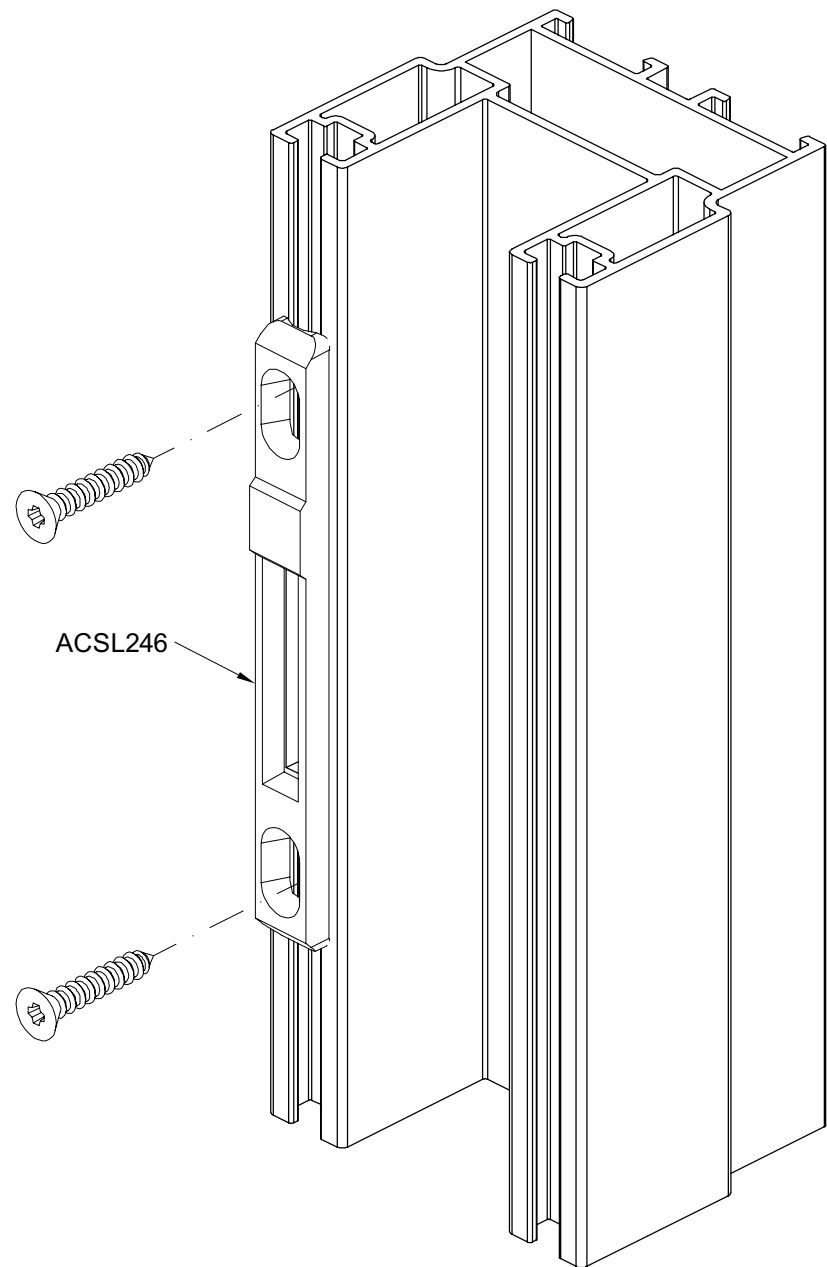

SL8110

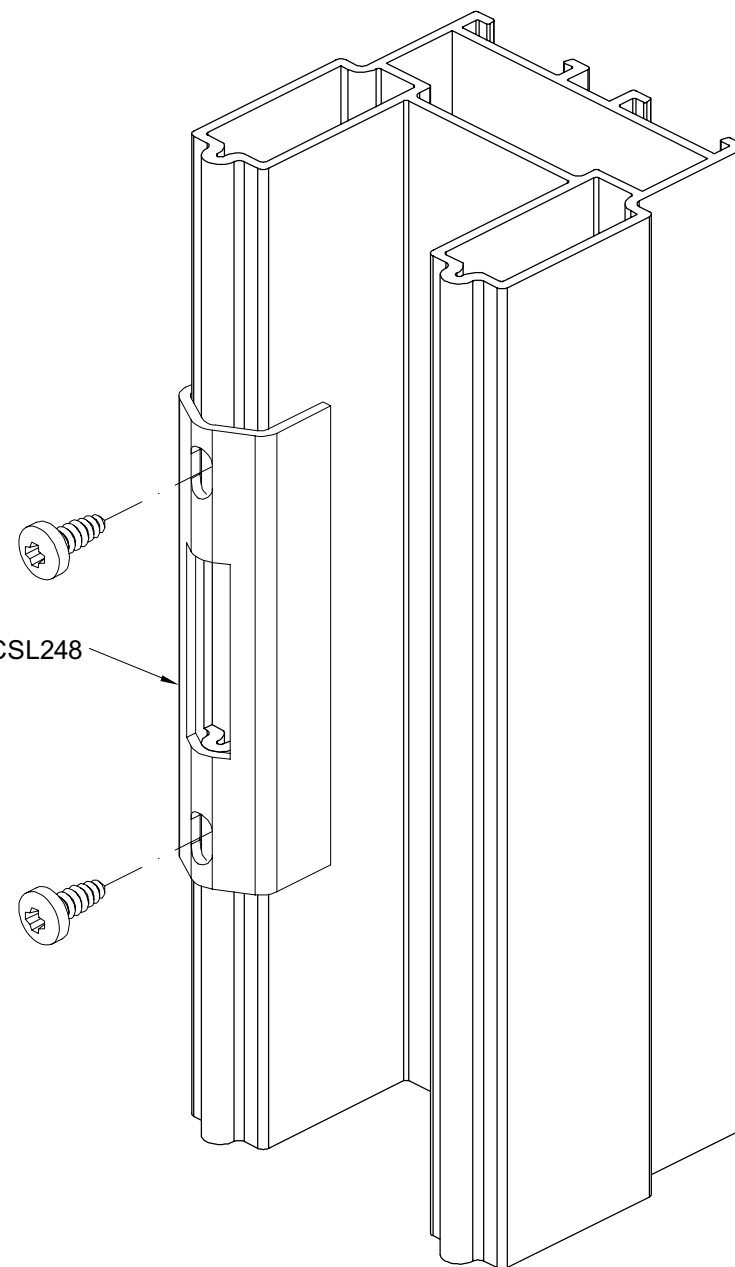
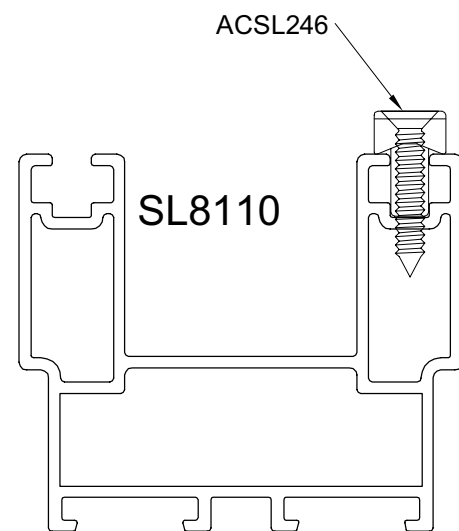

SL810

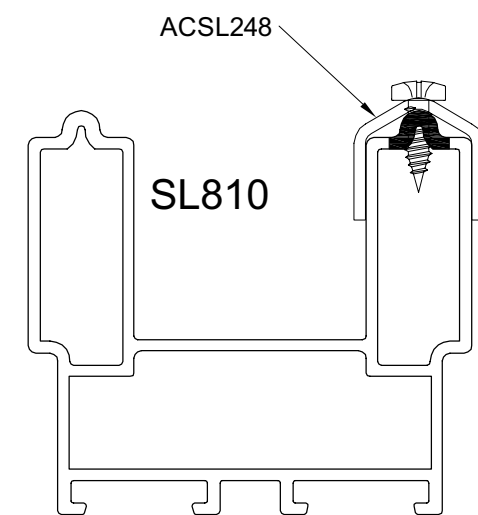

MONTAGE VLEUGEL
MONTAGE OUVRANT
MONTAGE FLUGEL
MONTAGE CASEMENT

WERKTEKENINGEN - DESSINS DE CONSTRUCTION - KONSTRUKTIONZEICHNUNGEN - CONSTRUCTION DRAWINGS

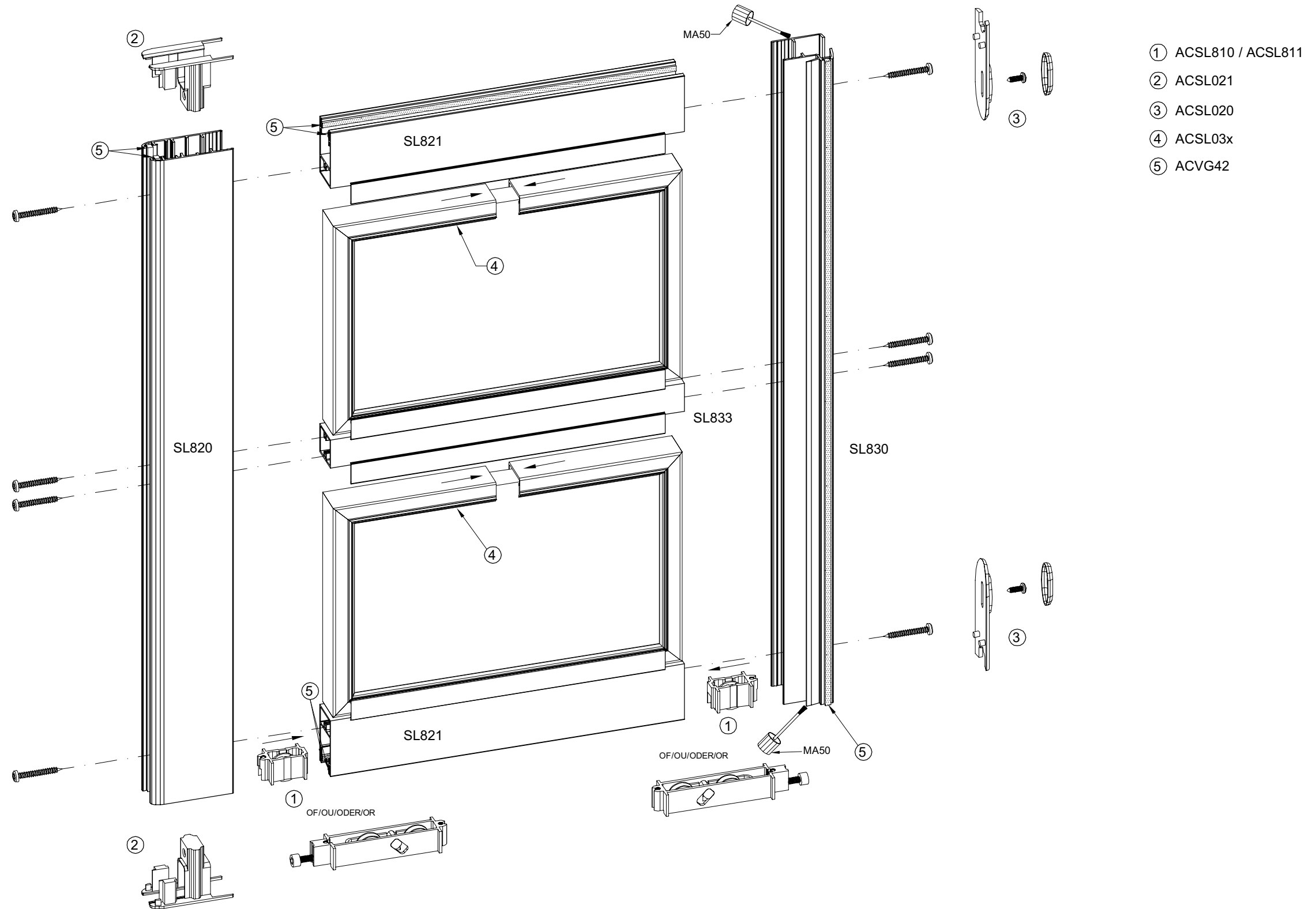

montagecold

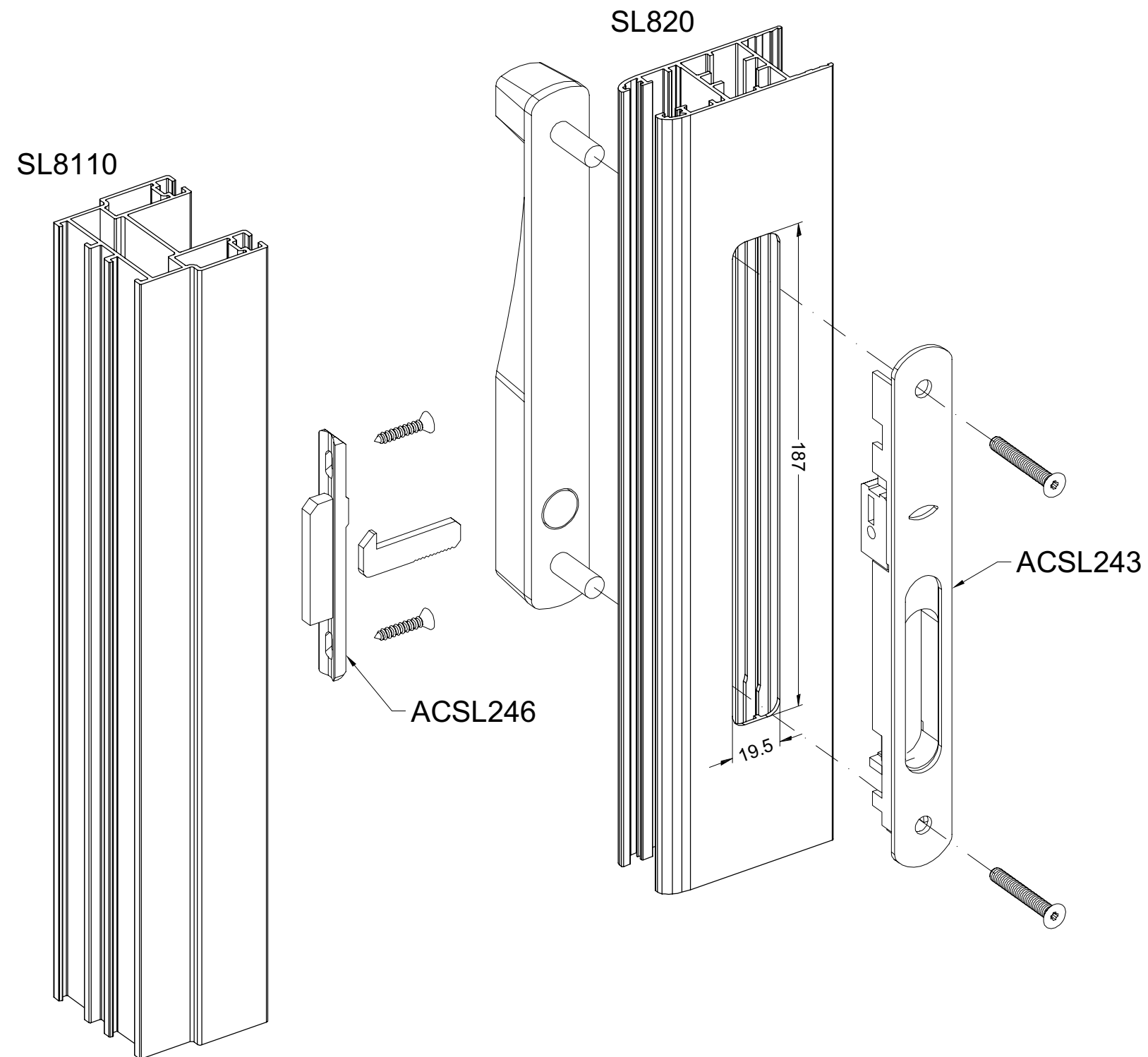

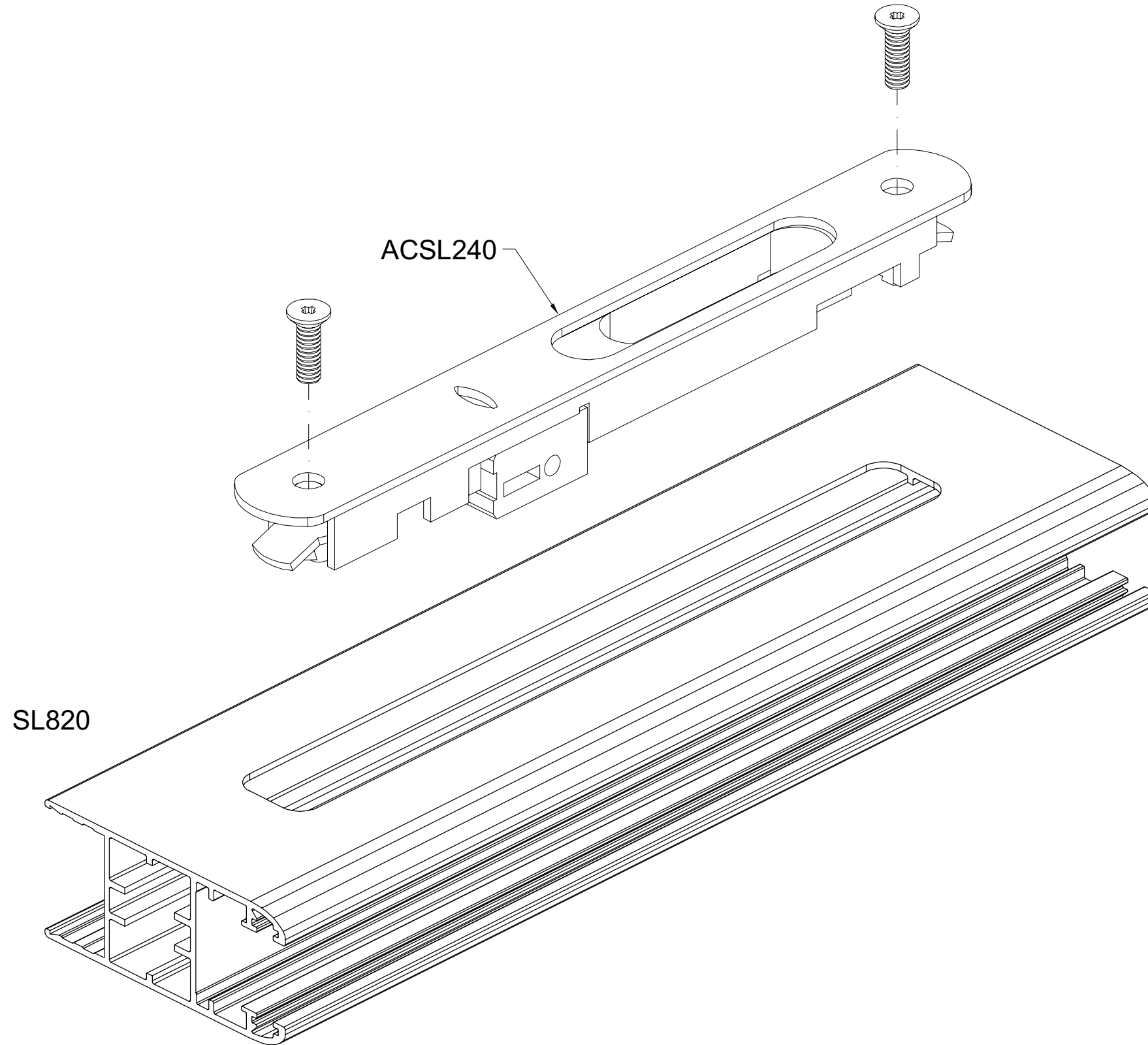

slot7

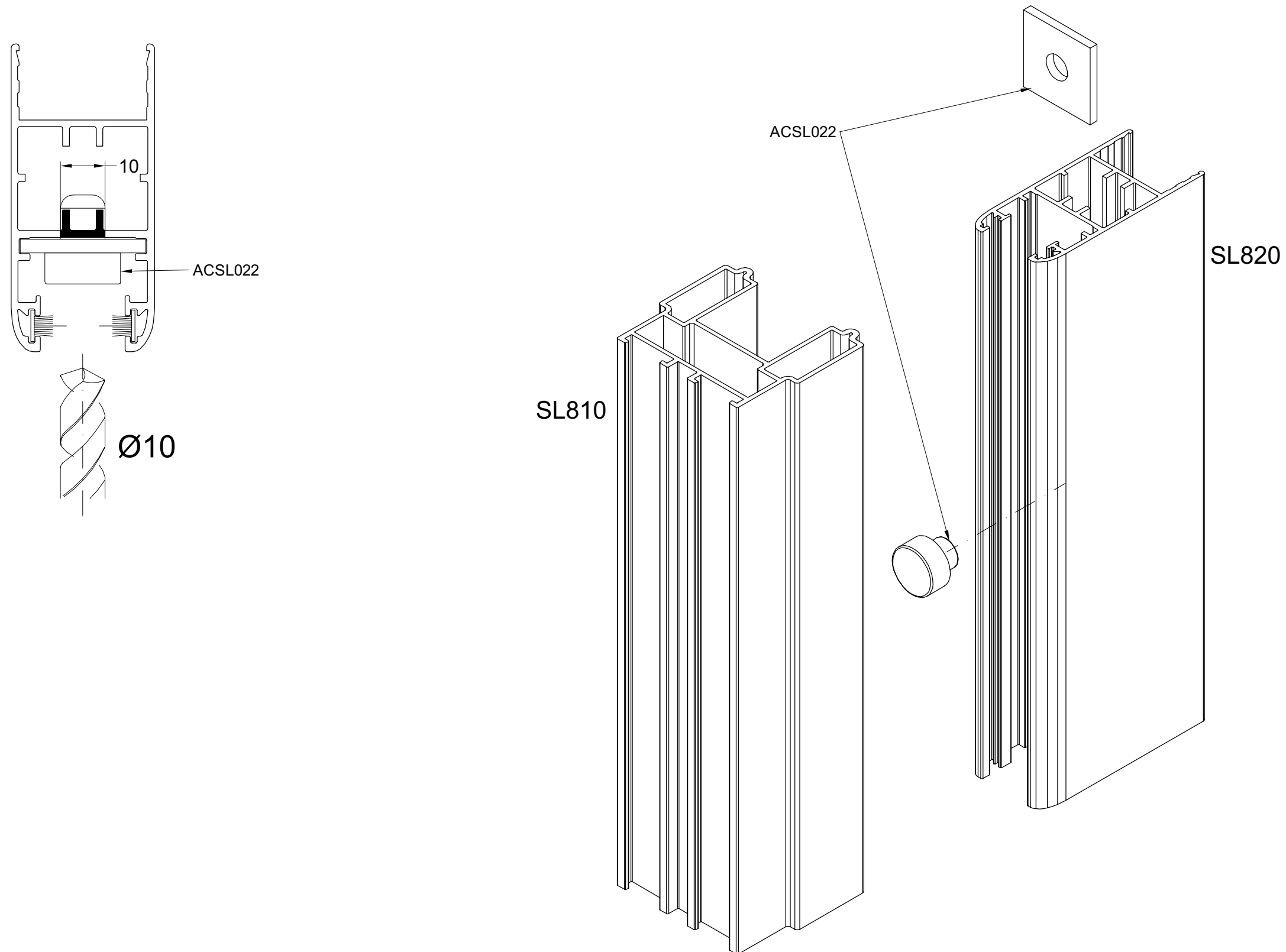

MONTAGE ACSL140
MONTAGE ACSL140
AUFSTELLEN ACSL140
ASSEMBLY ACSL140

WERKTEKENINGEN - DESSINS DE CONSTRUCTION - KONSTRUKTIONZEICHNUNGEN - CONSTRUCTION DRAWINGS

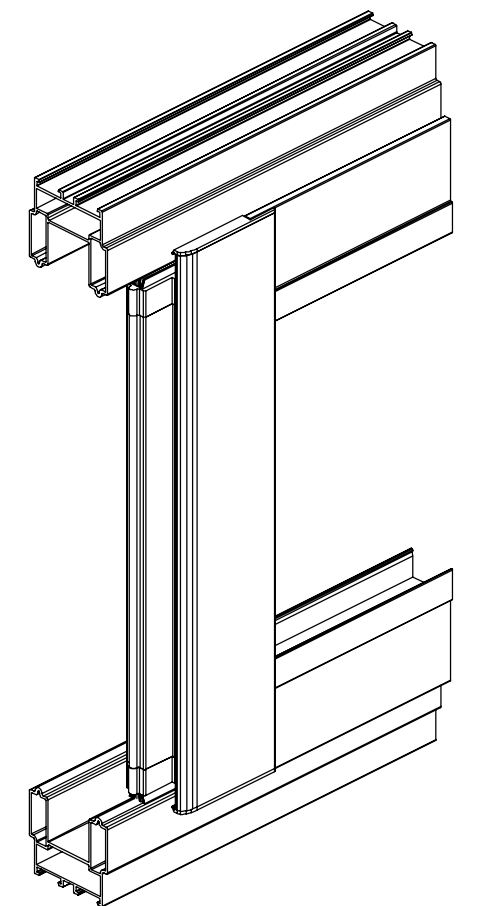
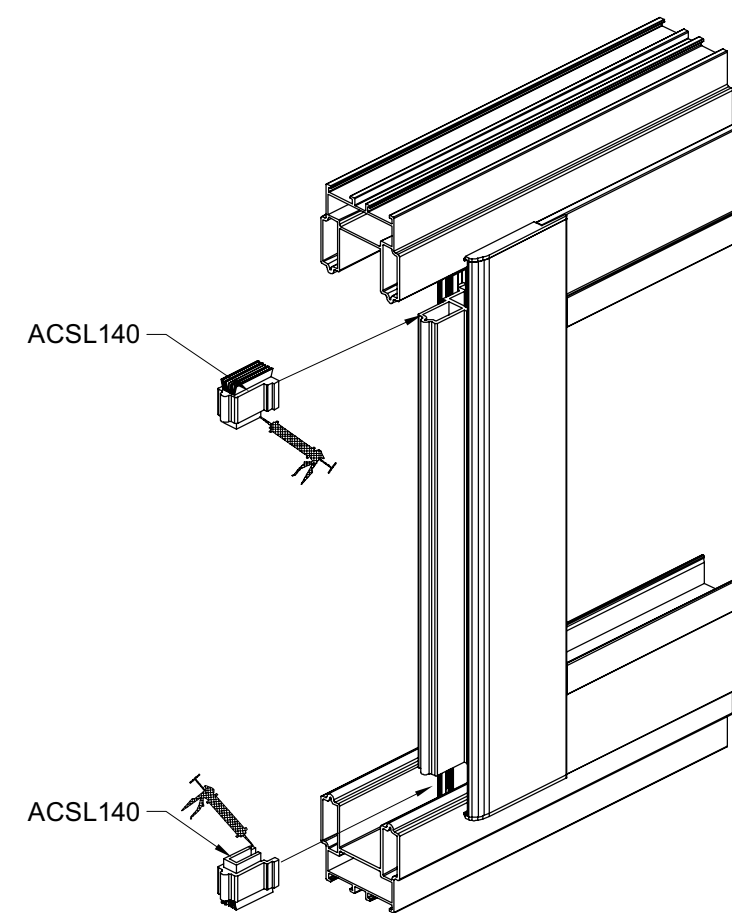
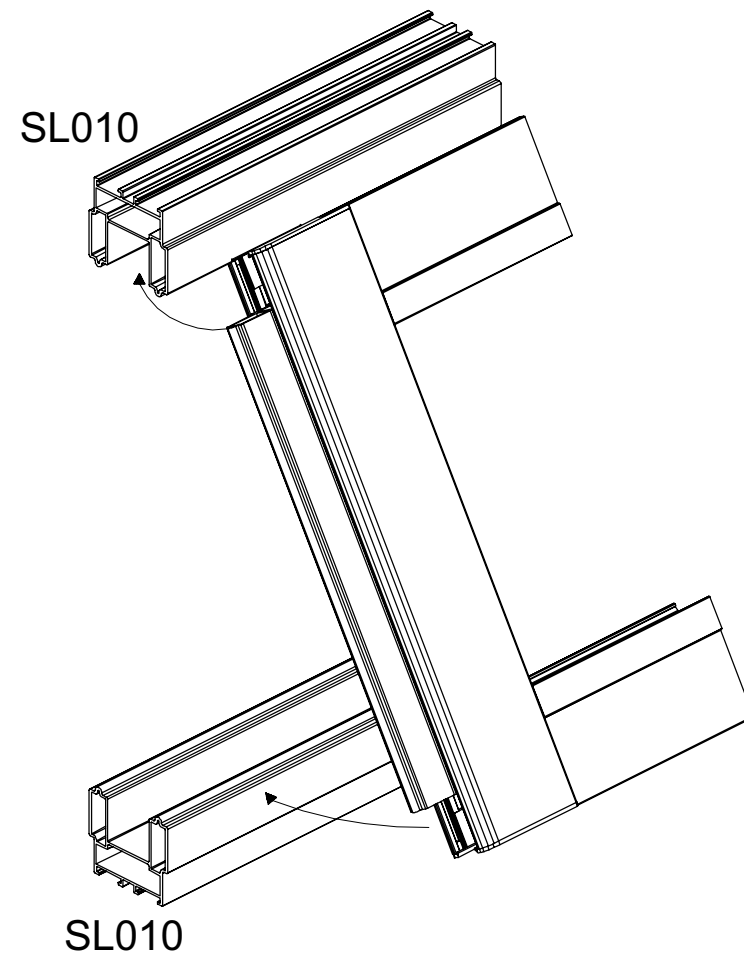
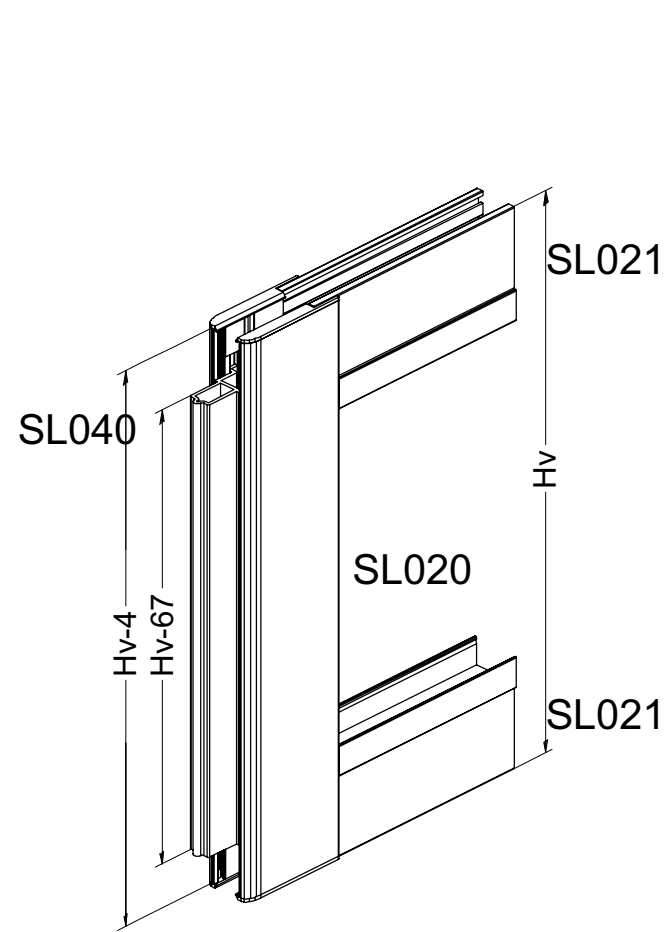
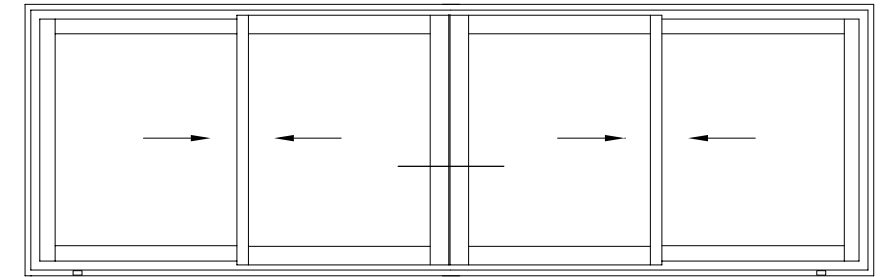
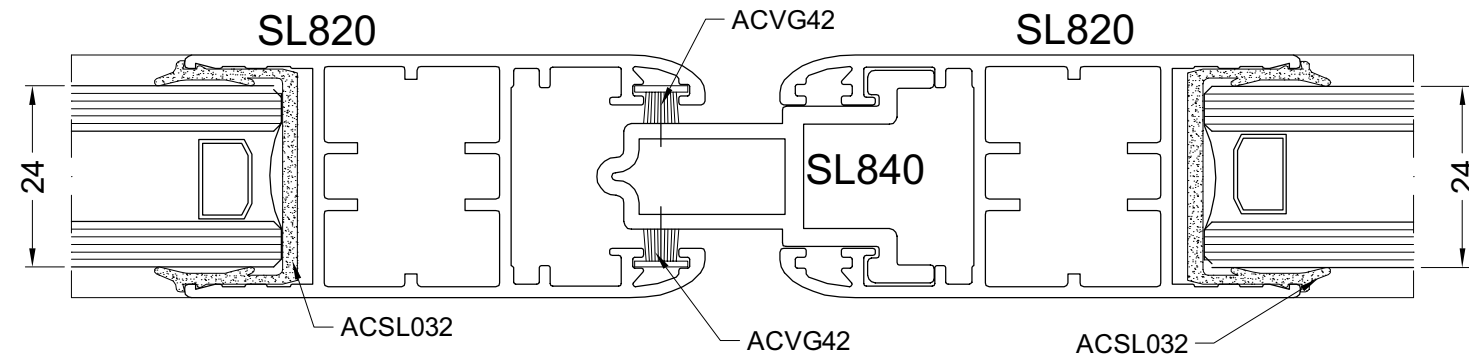

acsl140

MONTAGE BUITENKADER
MONTAGE DORMANT
MONTAGE RAHMEN
MONTAGE OUTER FRAME

WERKTEKENINGEN - DESSINS DE CONSTRUCTION - KONSTRUKTIONZEICHNUNGEN - CONSTRUCTION DRAWINGS

