

steel look

16/11/2007

RAMEN EN DEUREN
FENETRES ET PORTES
FENSTER UND TUREN
WINDOWS AND DOORS

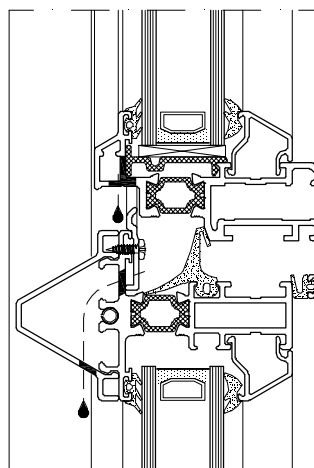

STa	PROFIELEN _____ P. 9 PROFILS PROFILE PROFILES
STb	TOEBEHOREN _____ P. 25 ACCESSOIRES ZUBEHORTEILE ACCESSORIES
STc	DOORSNEDEN _____ P. 57 COUPES SCHNITT SECTIONS
STd	STATICA _____ P. 101 STATIQUE STATIK STATICS
STe	ZAAGTABELLEN _____ P. 105 TABLES DE SCIAGES ZUSCHNITT-TABELLEN SAWING TABLES
STf	WERKTEKENINGEN _____ P. 115 DESSINS DE CONSTRUCTION KONSTRUKTIONZEICHNUNGEN CONSTRUCTION DRAWINGS

AFKORTINGEN / ABBREVIATIONS / ABKURZUNGEN / ABBREVIATIONS

BR = BRUT - BRUT - ROH - BRUT

AN = GEANODISEERD - ANODISE - ELOXIERT - ANODISED

AN (■) = GELAKT - LAQUE - LACKIERT - LACQUERED -- RAL9006M

KL = STANDAARDKLEUREN - COULEURS STANDARDS - BASIS FARBEN - BASIC COLORS

GS = SPECIAAL GEMOFFELD - LAQUE SPECIAL - SPECIALFARBE - SPECIAL COLOR

Z = ZWART - NOIR - SCHWARZ - BLACK

W = WIT - BLANC - WEISS - WHITE

De tekeningen die voorgesteld zijn op schaal 1:1, kunnen kleine maatafwijkingen vertonen, te wijten aan de reproductietechniek van deze catalogoog.

Les dessins représentés à l'échelle 1 peuvent avoir de légères variations dimensionnelles dues aux techniques de reproduction de ce catalogue.

Die Zeichnungen im Maßstab 1:1 können aus technischen Reproduktionsgründen leichte Messungsschwankungen darstellen.

The drawings represented on a scale 1 basis may have light dimensional variations due to the reproduction of the manual.

BUITENKADERS	P. 13
PROFILS D'ENCADREMENT KADERPROFILE OUTER FRAMES	
BUITENKADERS VOOR DEUREN	P. 14
PROFILS D'ENCADREMENT POUR PORTES KADERPROFILE FUR TUREN OUTER FRAMES FOR DOORS	
VLEUGELPROFIELEN	P. 15
OUVRANTS FLUGELPROFILE VENT PROFILES	
VLEUGELPROFIELEN VOOR DEUREN	P. 16
OUVRANTS POUR PORTES FLUGELPROFILE FUR TUREN VENT PROFILES FOR DOORS	
TUSSENREGELS	P. 17
TRAVERS SPROSSENPROFILE TRANSOMS	
STOLPPROFIELEN	P. 19
MAUCLAIRS STULP PROFILE DOUBLE CASEMENT PROFILES	
DORPELPROFIELEN VOOR DEUREN	P. 20
SEUILS POUR PORTES SOLLPROFILE FUR TUREN SILL MEMBERS FOR DOORS	
GLASLATTEN	P. 21
LATTES A VITRAGE GLASLEISTE GLAZING BEADS	
KOPPELPROFIELEN	P. 22
PROFILS COUPLAGE KUPPLUNG PROFILE COUPLING PROFILES	
DIVERSE PROFIELEN	P. 24
PROFILS DIVERS DIVERS PROFIEN VARIED PROFILES	

RAMEN _____ P. 57

FENETRES
RAHMEN
WINDOWS

DEUREN _____ P. 71

PORTES
TUREN
DOORS

GLASMATEN _____ P. 99

DIMENSIONS DES VITRAGES
GLASMASSE
GLASS SIZES

VAST RAAM _____	P. 105
CHASSIS FIXE FEST FELD FIXED WINDOW	
ENKEL RAAM _____	P. 106
OUVRANT A LA FRANCAISE DREHFLUGEL CASEMENT WINDOW	
STOLPRAAM _____	P. 107
DOUBLE OUVRANT A LA FRANCAISE STULPFENSTER DOUBLE CASEMENT WINDOW	
OPENDRAAIEND RAAM MET BOVEN, - ONDER EN ZIJLICHTEN _____	P. 108
SIMPLE OUVRANT AVEC IMPOSTE OU PARTIE LATERALE STULPFENSTER MIT OBERLICHT ODER SEITENFENSTER CASEMENTS WINDOW WITH FANLIGHT OR SIDE WINDOW	
ENKELE DEUR _____	P. 109
PORTE SIMPLE ANSCHLAGTUR SINGLE DOOR	
DUBBELE DEUR _____	P. 113
PORTE DOUBLE DOPPELT TUR DOUBLE DOOR	
ENKELE DEUR MET ZIJLICHTEN _____	P. 114





TOEPASSINGSBEREIK OPENDRAAIEND RAAM	P. 115
PORTEE D'UTILISATION OUVRANT A LA FRANCAISE ANWENDUNGSBEREICH DREHFLUGEL APPLICATION LIMIT CASEMENT WINDOW	
KOPPELPROFIELEN	P. 116
PROFILS COUPLAGE KUPPLUNG PROFILE COUPLING PROFILES	
MONTAGE ST030	P. 117
MONTAGE ST030 MONTAGE ST030 MONTAGE ST030	
MONTAGE ACST032	P. 118
MONTAGE ACST032 MONTAGE ACST032 MONTAGE ACST032	
MONTAGE ACST030	P. 121
MONTAGE ACST030 MONTAGE ACST030 MONTAGE ACST030	
MONTAGE ACST025	P. 124
MONTAGE ACST030 MONTAGE ACST030 MONTAGE ACST030	
MONTAGE VERDOKEN SCHARNIER	P. 125
MONTAGE PAUMELLE CACHE MONTAGE VERBORGEN BAND MONTAGE HIDDEN HINGE	
ONDERSCHIED VERTIKALE EN HORIZONTALE TUSSENREGELS	P. 126
DIFFERENCE TRAVERS VERTICALE ET HORIZONTAL UNTERSCHIED VON DIE VERTIKALE UND HORIZONTALE SPROSSENPROFILE DIFFERENCE BETWEEN VERTICAL EN HORIZONTAL TRANSOMS	
MOGELIJKHEDEN VLEUGELS	P. 127
POSSIBILITES OUVRANTS MOGLICHKEITEN FLUGELPROFILE POSSIBILITIES VENTS	
MONTAGE ACST054	P. 128
MONTAGE ACST054 MONTAGE ACST054 MONTAGE ACST054	
MONTAGE ACST154	P. 129
MONTAGE ACST154 MONTAGE ACST154 MONTAGE ACST154	

MONTAGE BOORMAL VOOR WATERGAT _____ P. 130
MONTAGE CALIBRE POUR ECOULEMENT D'EAU
MONTAGE BOHRSCHABLONE FUR ENTWASSERUNG
MONTAGE BORING JET SET FOR DRAIN HOLE

MONTAGE SLOT IN ST110-ST023 _____ P. 131
MONTAGE SERRURE DANS ST110-ST023
MONTAGE SCHLOSSER IN ST110-ST023
MONTAGE LOCK IN ST110-ST023

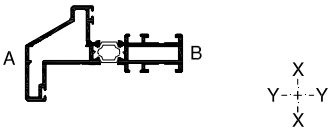
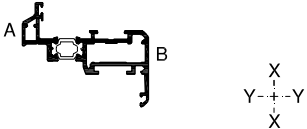
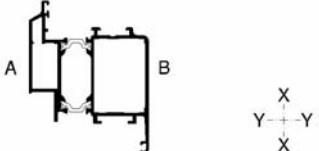
UITSPARING VOOR SLOT ACVL705, ACVL706, ACVL707, ACVL708 _____ P. 132
ENTAILLE POUR SERRURES ACVL705, ACVL706, ACVL707, ACVL708
EINBAU FUR SCHLOSSER ACVL705, ACVL706, ACVL707, ACVL708
EMBEDDING FOR LOCK ACVL705, ACVL706, ACVL707, ACVL708

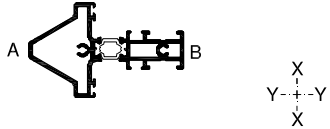
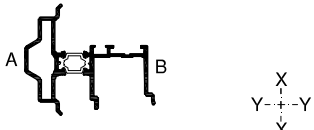
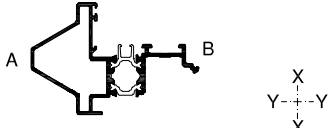
MONTAGE ST-VICTORIAN _____ P. 133
MONTAGE ST-VICTORIAN
MONTAGE ST-VICTORIAN
MONTAGE ST-VICTORIAN

NUMMER NUMERO NUMBER	AFBEELDING IMAGE BILD PICTURE	BLAD PAGE SEITE PAGE	OMTREK PERIM. UMRIB PERIM. mm	MECH. MEC. MECH. MEC. mm	Ix (cm4)		LENGTE LONG. LANGE LENGTH	VERP. PER EMB. PAR PACK PR.	BR	AN	KL	GS	M1
					Wy (cm3)	Wy (cm3)							
ST010		13	380.6	107	36.10	6.62	6,5	2	X	X	X	X	X
					7.92	2.64							
ST020		15	348.2	106	21.13	4.75	6.5	2	X	X	X	X	X
					5.67	1.60							
ST023		15	430.2	176.7	35.59	27.55	7	2	X	X	X	X	X
					10.47	6.14							
ST029		24	93.2	-	-	-	6.5	6	X	X	X	X	
ST030		17	373.2	120	29.34	6.67	6.5	2	X	X	X	X	X
					7.00	2.67							
ST040		19	404.3	108	18.12	7.51	6.5	2	X	X	X	X	X
					4.44	2.35							
ST041		19	407.7	131	23.67	9.88	6.5	2	X	X	X	X	X
					4.83	3.13							
ST060		21	59.7	11	-	-	6.5	2	X	X	X	X	
ST061		21	76.9	12.6	-	-	6.5	6	X	X	X	X	

BR = BRUT - BRUT - ROH - BRUT
 AN = ANODISATIE - ANODISE - ELOXIERT - ANODISED
 KL = STANDAARDKLEUREN - COULEUR STANDARD - BASIS FARBEN - BASIC COLORS
 GS = GEMOFFELD SPECIAAL - LAQUE SPECIAL - SPECIALFARBE - SPECIAL COLOR
 M1 = BICOLOR - BICOLOR - BICOLOR - BICOLOR

A = BUITEN - EXTERIEUR - AUSSEN - OUTSIDE
 B = BINNEN - INTERIEUR - INNEN - INSIDE

NUMMER NUMERO NUMBER	AFBEELDING IMAGE BILD PICTURE	BLAD PAGE SEITE PAGE	OMTREK PERIM. UMRIB PERIM. mm	MECH. MEC. MECH. MEC. mm	Ix (cm4)	Iy (cm4)	LENGTE LONG. LANGE LENGTH	VERP. PER EMB. PAR PACK PR.	BR	AN	KL	GS	M1
					Wx (cm3)	Wy (cm3)							
ST062		21	108.5	27	-	-	6.5	6	X	X	X	X	
ST110		13	352.1	81.4	29.09	3.76	6.5	2	X	X	X	X	X
					7.00	1.69							
ST120		15	345.5	110.3	20.98	4.73	6.5	2	X	X	X	X	X
					5.63	1.59							
ST130		18	384.7	30	13.74	3.56	6.5	2	X	X	X	X	X
					4.20	1.42							
ST131		24	194.4	89.4	-	-	6.5	2	X	X	X	X	
ST162		21	118.9	32.5	-	-	6.5	6	X	X	X	X	
ST163		21	122.6	29.8	-	-	6.5	6	X	X	X	X	
ST164		21	76.1	26.9	-	-	6.5	6	X	X	X	X	
ST210		13	277.4	61	9.66	1.93	6.5	2	X	X	X	X	X
					3.54	0.84							





BR = BRUT - BRUT - ROH - BRUT

AN = ANODISATIE - ANODISE - ELOXIERT - ANODISED

KL = STANDAARDKLEUREN - COULEUR STANDARD - BASIS FARBEN - BASIC COLORS

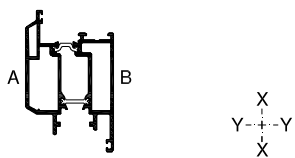
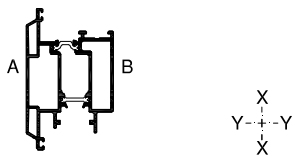
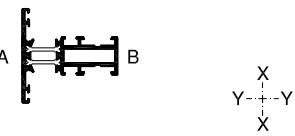
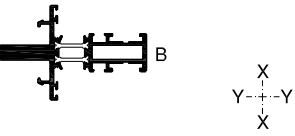
GS = GEMOFFELD SPECIAAL - LAQUE SPECIAL - SPECIALFARBE - SPECIAL COLOR

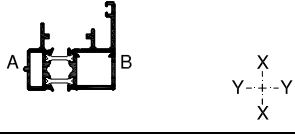
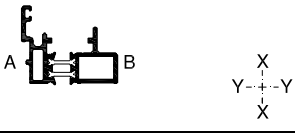









M1 = BICOLOR - BICOLOR - BICOLOR - BICOLOR

NUMMER NUMERO NUMBER	AFBEELDING IMAGE BILD PICTURE	BLAD PAGE SEITE PAGE	OMTREK PERIM. UMRIB PERIM. mm	MECH. MEC. MECH. MEC. mm	lx (cm4)		ly (cm4)		LENGTE LONG. LANGE LENGTH	VERP. PER EMB. PAR PACK PR.	BR	AN	KL	GS	M1
					Wx (cm3)	Wy (cm3)	Wx (cm3)	Wy (cm3)							
ST224		16	446.4	189.7	30.31	37.93	9.92	7.86	7		X	X	X	X	X
ST225		16	446.1	189.2	30.36	40.83	9.49	8.67	7		X	X	X	X	X
ST230		18	323.6	78.7	11.24	3.25	3.80	1.30	6.5	2	X	X	X	X	X
ST330		18	408.7	29.8	30.30	3.92	6.84	1.57	6.5	2	X	X	X	X	X
ST331		24	200	91.5	-	-	-	-	6.5	6	X	X	X	X	
TL055		24	204.8	42	-	-	-	-	6.5	2	X	X	X	X	
TL218		14	284.9	82.6	10.26	5.56	3.77	1.88	6.5	2	X	X	X	X	X
TL219		14	274.1	80.3	9.47	3.80	3.29	1.43	6.5	2	X	X	X	X	X
TL222		16	-	-	-	-	-	-	6.5	2					

BR = BRUT - BRUT - ROH - BRUT
 AN = ANODISATIE - ANODISE - ELOXIERT - ANODISED
 KL = STANDAARDKLEUREN - COULEUR STANDARD - BASIS FARBEN - BASIC COLORS
 GS = GEMOFFELD SPECIAAL - LAQUE SPECIAL - SPECIALFARBE - SPECIAL COLOR
 M1 = BICOLOR - BICOLOR - BICOLOR - BICOLOR

A = BUITEN - EXTERIEUR - AUSSEN - OUTSIDE
 B = BINNEN - INTERIEUR - INNEN - INSIDE

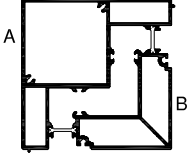
PROFIELEN - PROFILES - PROFILE - PROFILS

NUMMER NUMERO NUMBER	AFBEELDING IMAGE BILD PICTURE	BLAD PAGE SEITE PAGE	OMTREK PERIM. UMRIB PERIM. mm	MECH. MEC. MECH. MEC. mm	Ix (cm4)	Iy (cm4)	LENGTE LONG. LANGE LENGTH	VERP. PER EMB. PAR PACK PR. PACK PR.	BR	AN	KL	GS	M1
					Wx (cm3)	Wy (cm3)							
TL289		20	192.3	103.1	-	-	6.5	6	X	X	X	X	
TL290		20	196.5	125.3	-	-	6.5	6	X	X	X	X	
VL53	 	22	191	40	9.82 3.85	1.73 1.38	4.5 6.5	2	X	X	X	X	X
VL54	 	22	287.1	145	48.53 9.16	3.07 2.46	4.5 6.5	2	X	X	X	X	X
VL59		24	48	-	-	-	6	20		X			
VL60		24	46.2	21	-	-	6	20		X		X	
VL155	 	23	476.7	317	157.55 30.82	157.55 30.82	4.7	1	X	X	X	X	X
VL159		24	52.9	-	-	-	6	-		X			

BR = BRUT - BRUT - ROH - BRUT
AN = ANODISATIE - ANODISE - ELOXIERT - ANODISED
KL = STANDAARDKLEUREN - COULEUR STANDARD - BASIS FARBEN - BASIC COLORS
GS = GEMOFFELD SPECIAAL - LAQUE SPECIAL - SPECIALFARBE - SPECIAL COLOR
M1 = BICOLOR - BICOLOR - BICOLOR - BICOLOR

BUITENKADERS
PROFILS D'ENCADREMENT
KADERPROFILE
OUTER FRAMES

PROFIELEN - PROFILS - PROFILE - PROFILES

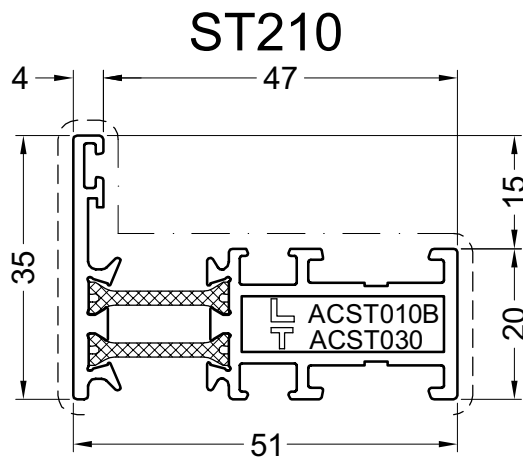
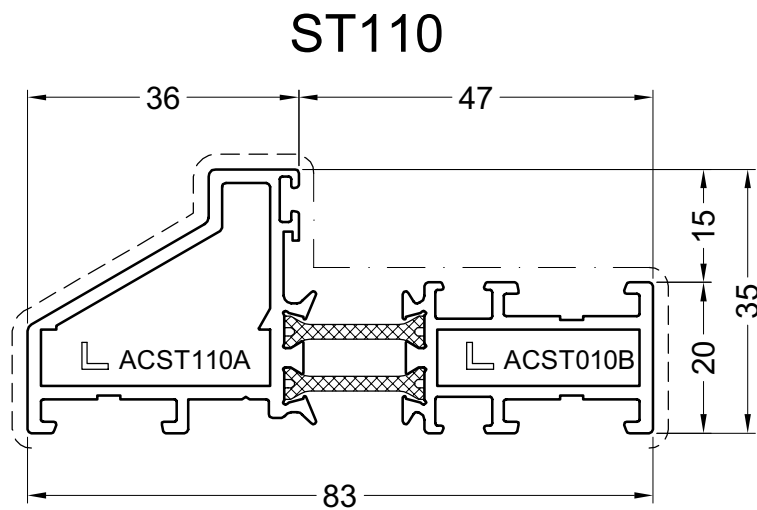
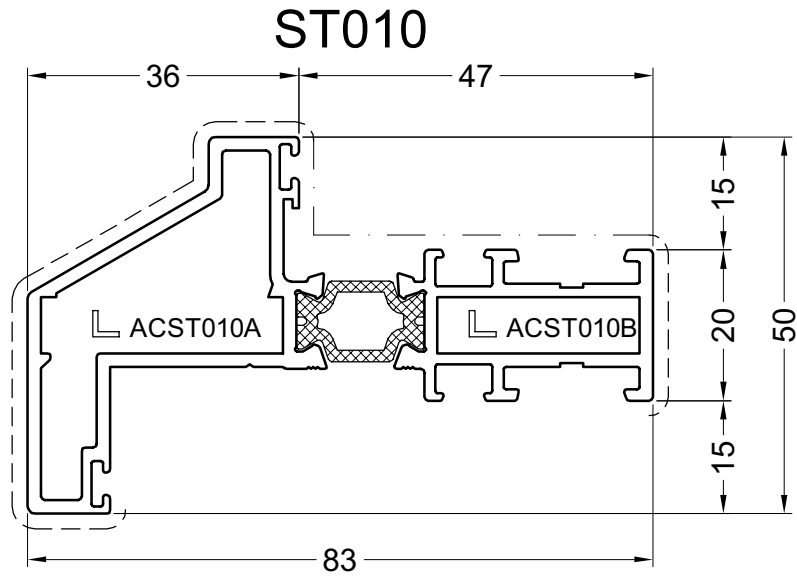

pag01

Primaire zichtbare zijde
Face visible primaire
Primär sichtbare Seite
Primary visible side

Secundaire zichtbare zijde
Face visible secondaire
Secondär sichtbare Seite
Secondary visible side

BUITENKADERS VOOR DEUREN
PROFILS D'ENCADREMENT POUR PORTES
KADERPROFILE FÜR TÜREN
OUTER FRAMES FOR DOORS

PROFIELEN - PROFILS- PROFILE - PROFILES

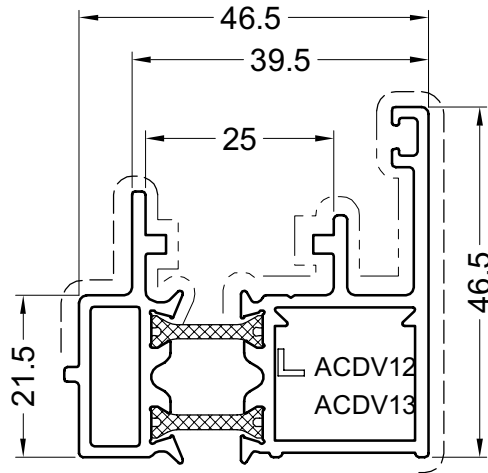

TL218

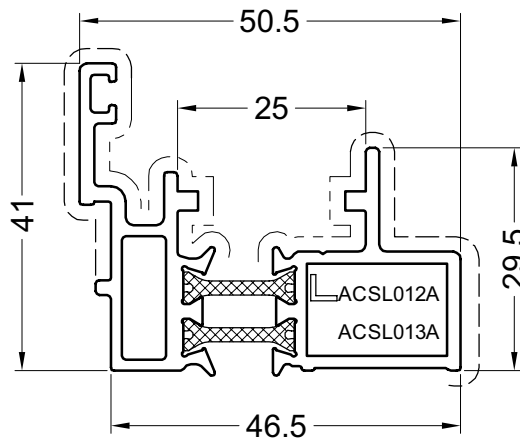

TL219

VLEUGELPROFIELEN
OUVRANTS
FLUGELPROFILE
VENT PROFILES

PROFIELEN - PROFILS- PROFILE - PROFILES

ST020

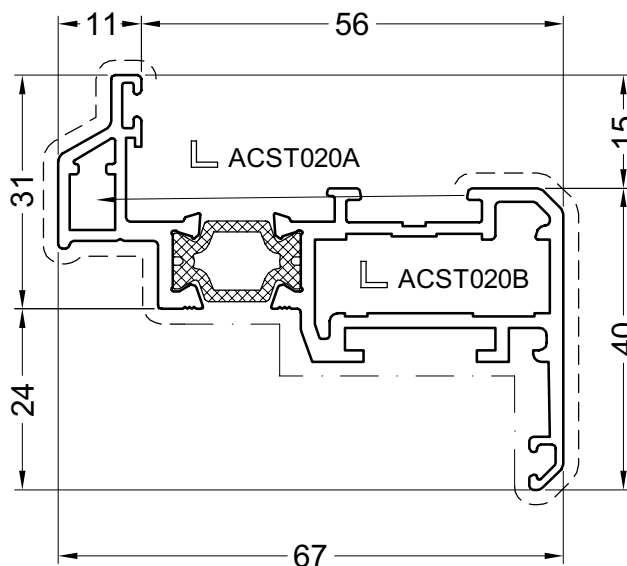

ST120

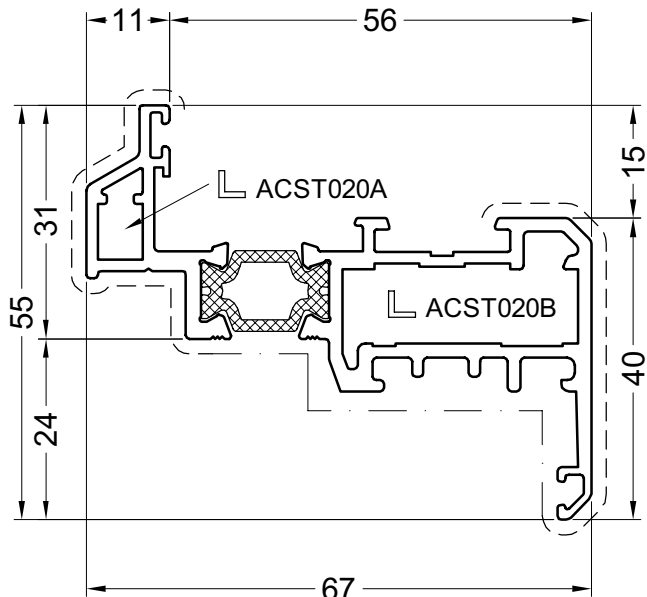

ST023

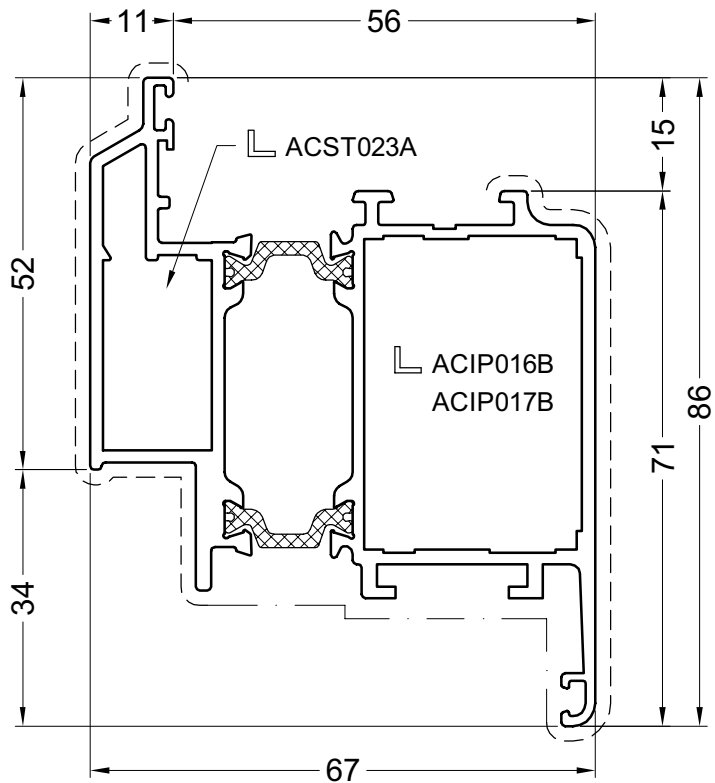

pag02

Primaire zichtbare zijde
Face visible primaire
Primär sichtbare Seite
Primary visible side

Secundaire zichtbare zijde
Face visible secondaire
Secondär sichtbare Seite
Secondary visible side

VLEUGELPROFIELEN VOOR DEUREN
OUVRANTS POUR PORTES
FLUGELPROFILE FÜR TÜREN
VENT PROFILES FOR DOORS

PROFIELEN - PROFILS - PROFILE - PROFILES

ST224

ST225

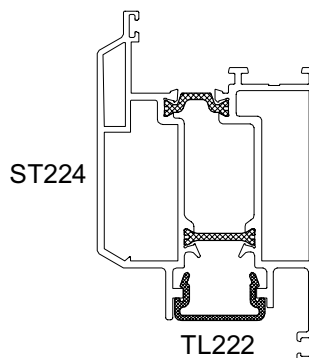
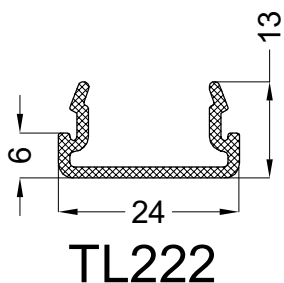
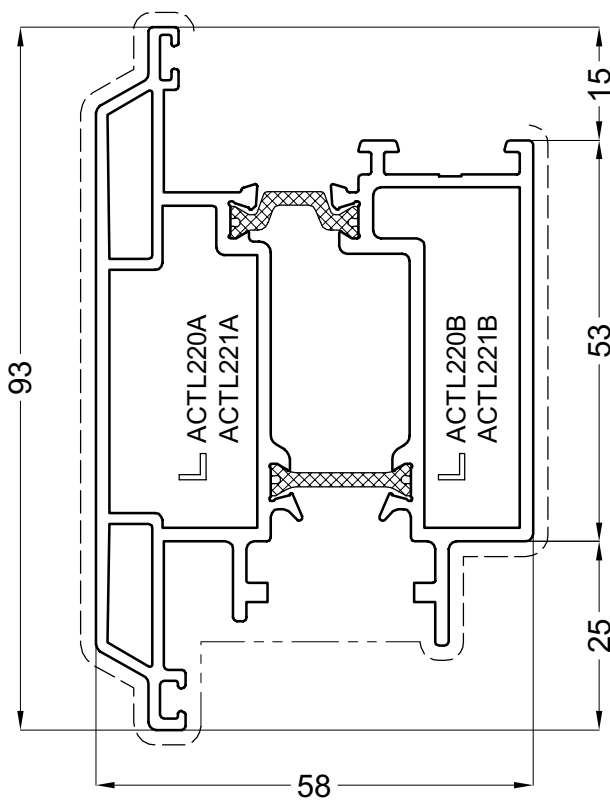
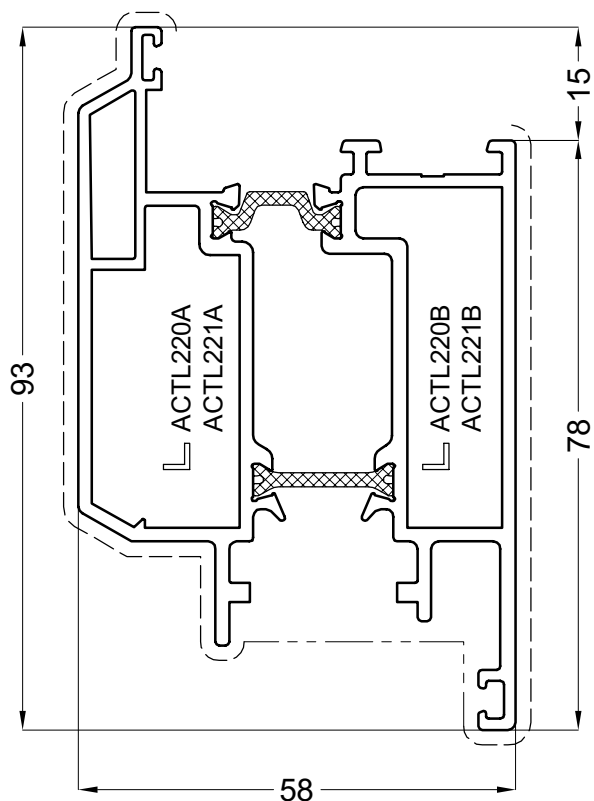

ST030

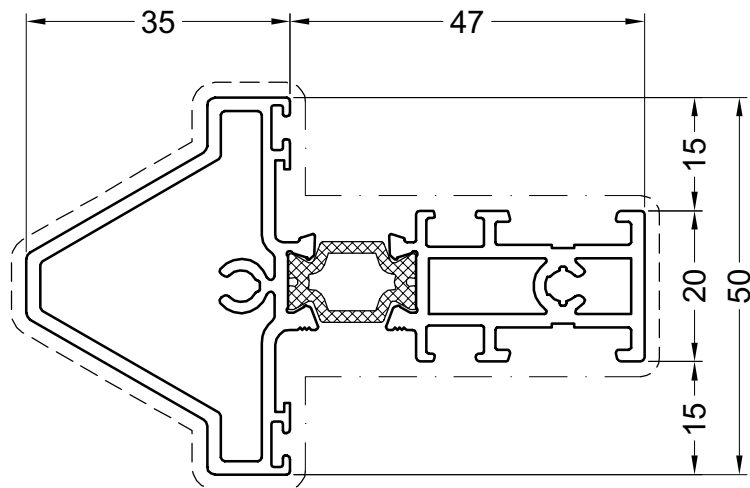

pag03

Primaire zichtbare zijde
Face visible primaire
Primär sichtbare Seite
Primary visible side

Secundaire zichtbare zijde
Face visible secondaire
Secondär sichtbare Seite
Secondary visible side

TUSSENREGELS
TRAVERS
SPROSSENPROFILE
TRANSOMS

PROFIELEN - PROFILS - PROFILE - PROFILES

ST230

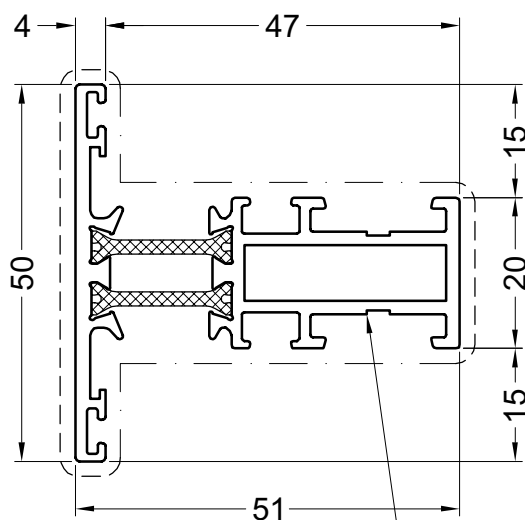

└ ACST010B
└ ACST030
ACST031

ST330

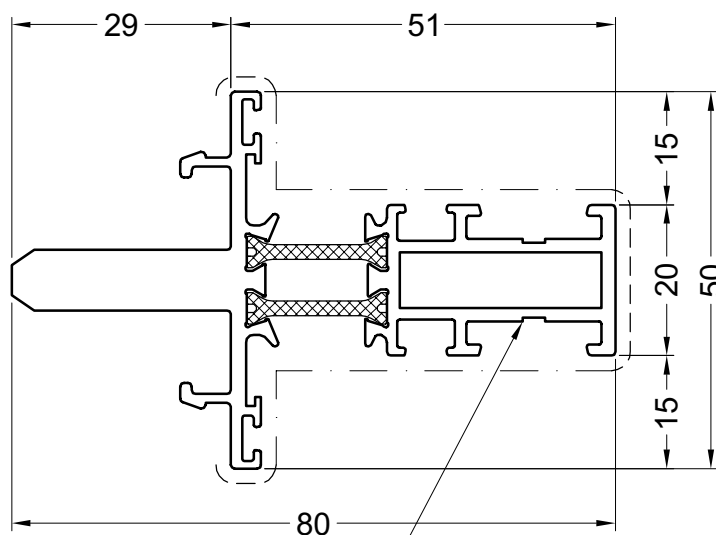

└ ACST010B
└ ACST030
ACST031

ST130

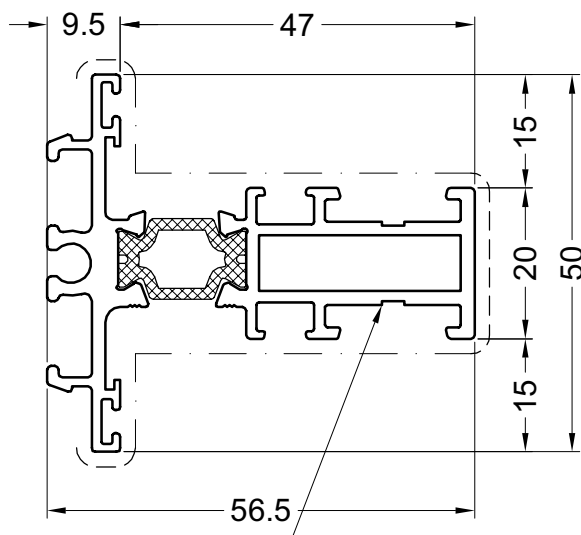

└ ACST010B
└ ACST030
ACST031

STOLPPROFIELN
MAUCLAIRS
STULP PROFILE
DOUBLE CASEMENT PROFILES

PROFIELEN - PROFILS- PROFILE - PROFILES

ST040

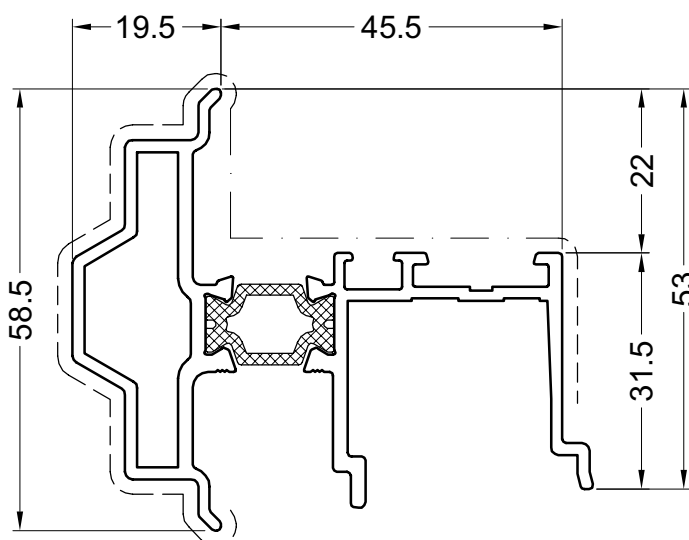

ST041

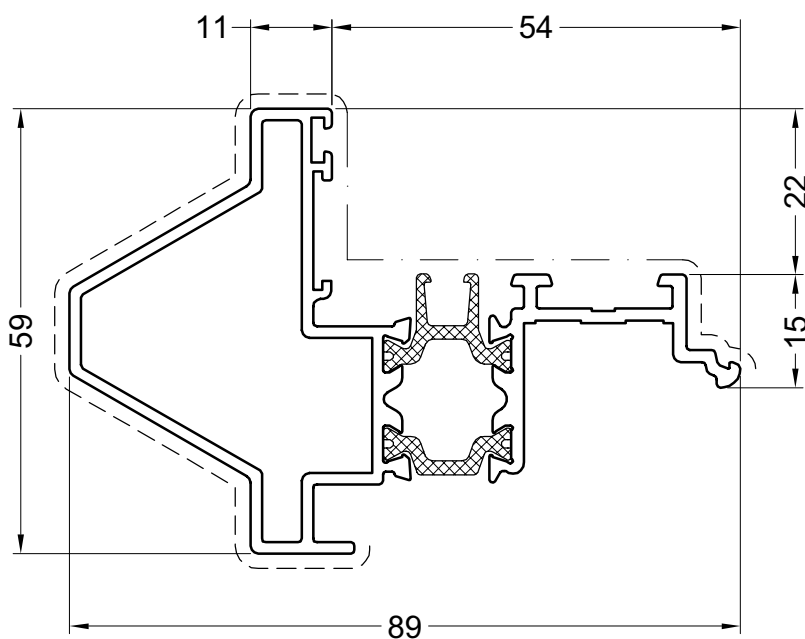

pag02b

Primaire zichtbare zijde
Face visible primaire
Primär sichtbare Seite
Primary visible side

Secundaire zichtbare zijde
Face visible secondaire
Secondär sichtbare Seite
Secondary visible side

DORPELPROFIELEN VOOR DEUREN
SEUILS POUR PORTES
SOLLPROFILE FÜR TÜREN
SILL MEMBERS FOR DOORS

PROFIELEN - PROFILS - PROFILE - PROFILES

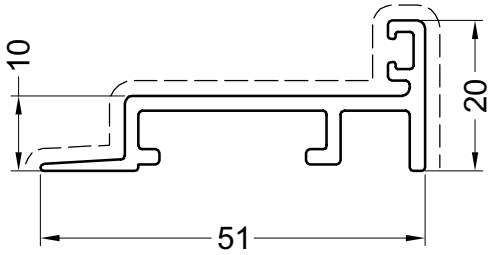

TL289

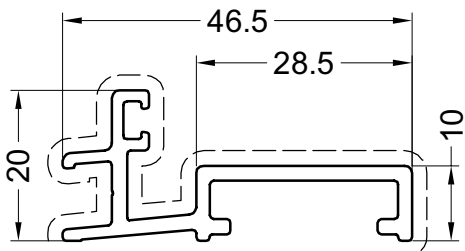
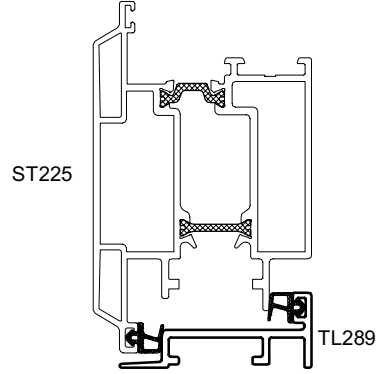

TL290

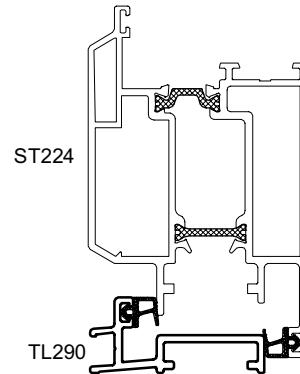

GLASLATTEN
LATTES A VITRAGE
GLASLEISTE
GLAZING BEADS

PROFIELEN - PROFILS- PROFILE - PROFILES

ST062

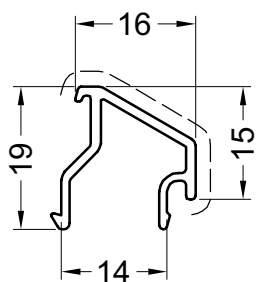

ST162

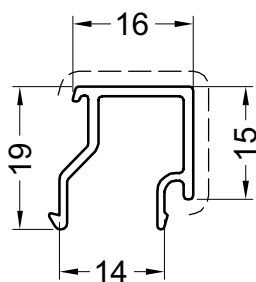

ST163

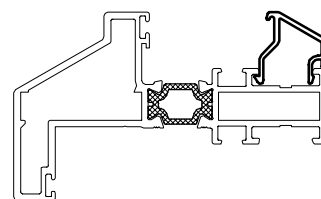
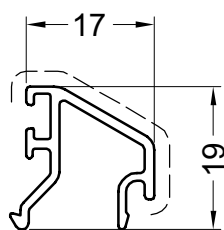

ST164

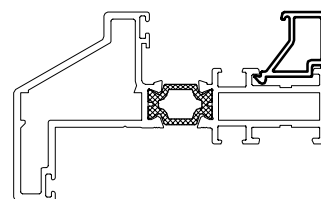
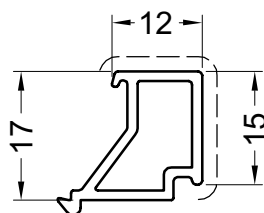

ST060

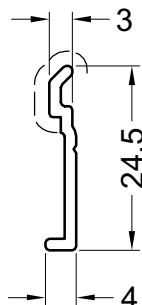

ST061

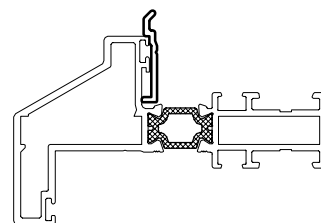
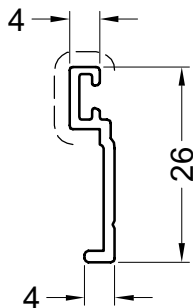

pag05

Primaire zichtbare zijde
Face visible primaire
Primär sichtbare Seite
Primary visible side

Secundaire zichtbare zijde
Face visible secondaire
Secondär sichtbare Seite
Secondary visible side

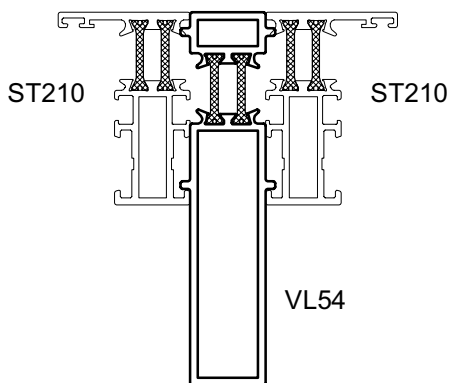
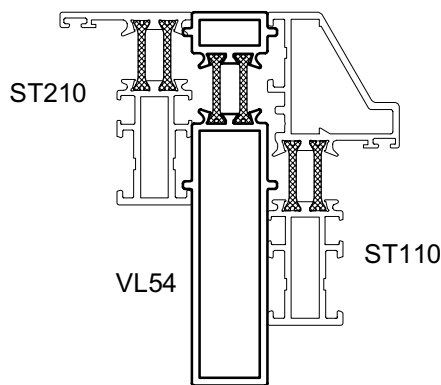
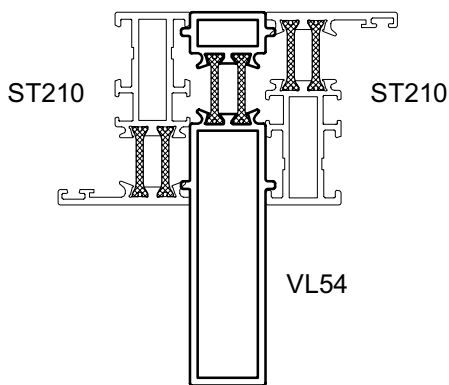
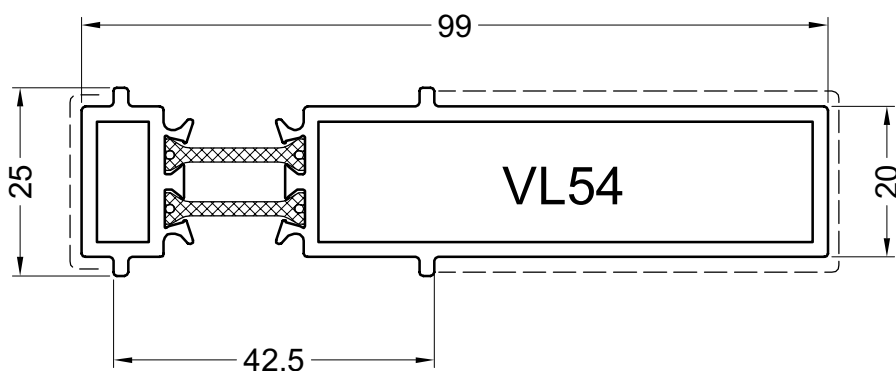
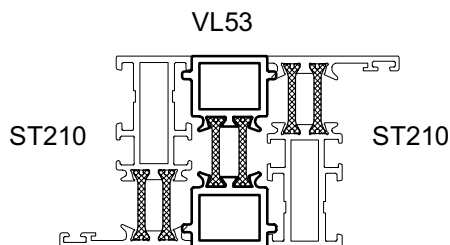
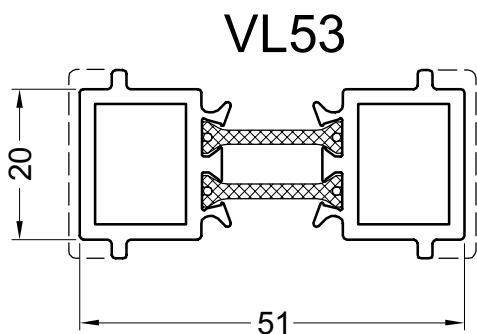

KOPPELPROFIELEN
PROFILS COUPLAGE
KUPPLUNG PROFILE
COUPLING PROFILES

PROFIELEN - PROFILS- PROFILE - PROFILES

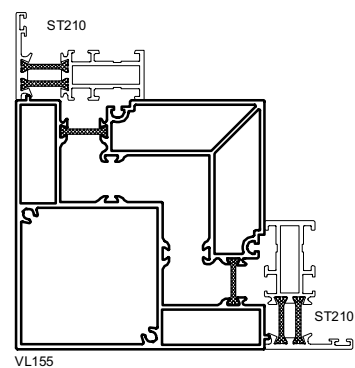
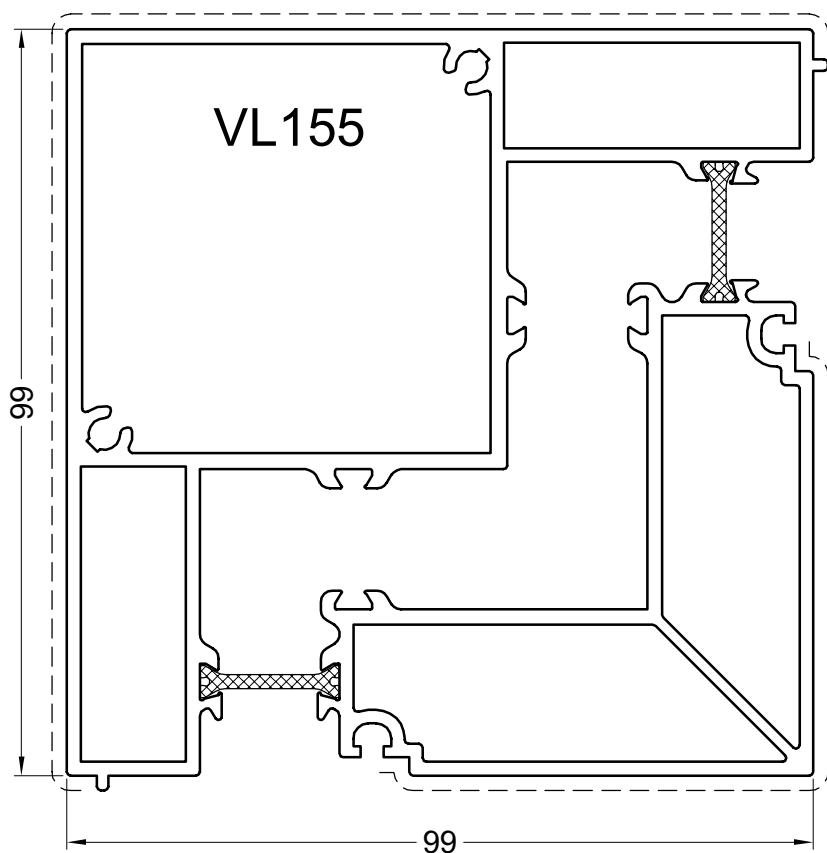

pag10a

Primaire zichtbare zijde
Face visible primaire
Primär sichtbare Seite
Primary visible side

Secundaire zichtbare zijde
Face visible secondaire
Secondär sichtbare Seite
Secondary visible side

7/9/07

23

DIVERSE PROFIELEN
PROFILS DIVERS
DIVERS PROFILN
VARIED PROFILES

PROFIELEN - PROFILS - PROFILE - PROFILES

ST029

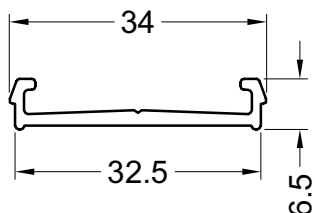

VL59

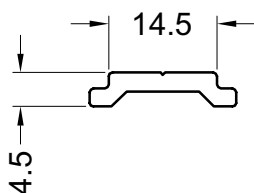

VL60

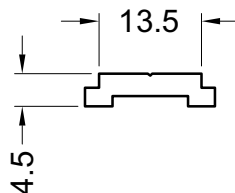

VL159

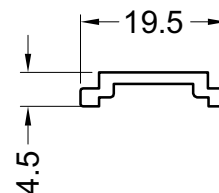

TL055

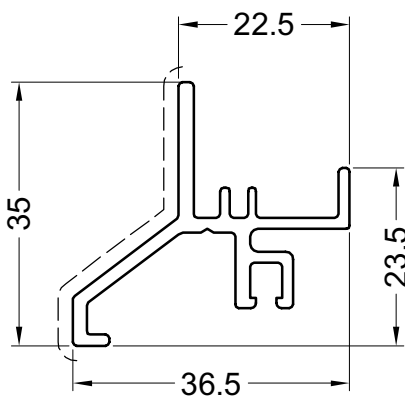

ST131

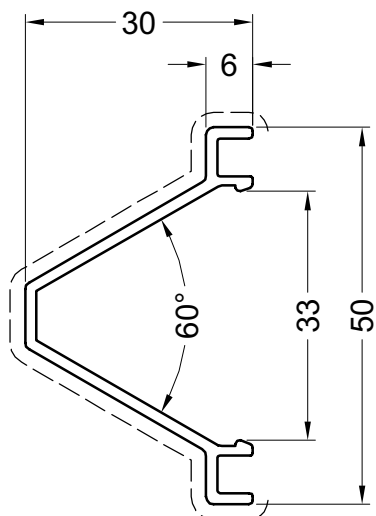

ST331

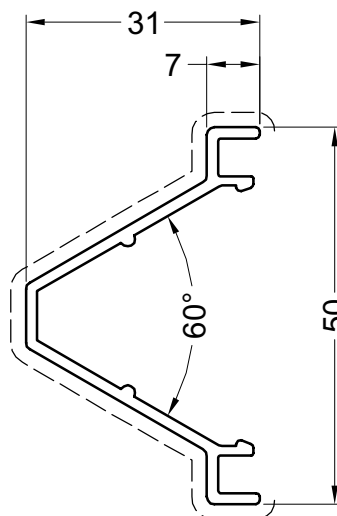

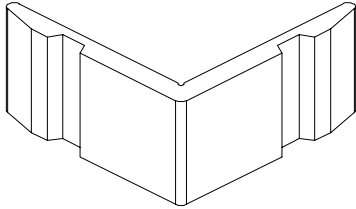
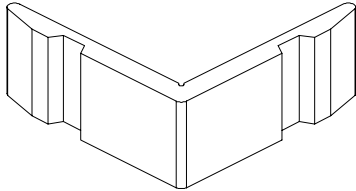
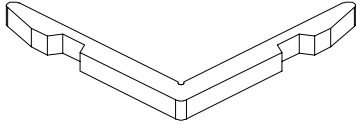
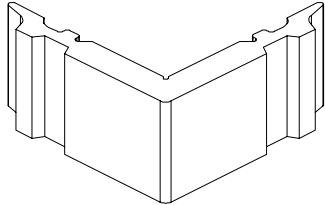
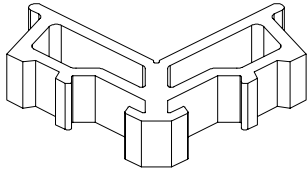
		Verp. per Emb. par Pack pr. Unit	Einheid Unité Einheit Unit	Toepassing Application Anwendung Application	Kleur Couleur Farbe Color											
 <p>ACST010A</p> <ul style="list-style-type: none"> -Pershoek voor buitenste kamer -Clame à presser pour chambre extérieure -Eckverbinder Stanzbar für aussere kammer -Clamping corner for outside chamber <p>X=7mm Y=32mm</p>	1	Stuk Pièce Stück Pièce	ST010	<table border="1"> <tr><td>BR</td><td></td></tr> <tr><td>AN</td><td></td></tr> <tr><td>KL</td><td></td></tr> <tr><td>GS</td><td></td></tr> <tr><td>Z</td><td></td></tr> <tr><td>W</td><td></td></tr> </table>	BR		AN		KL		GS		Z		W	
BR																
AN																
KL																
GS																
Z																
W																
 <p>ACST010B</p> <ul style="list-style-type: none"> -Pershoek voor binnenste kamer -Clame à presser pour chambre intérieure -Eckverbinder Stanzbar für innere kammer -Clamping corner for inside chamber <p>X=7mm Y=27mm</p>	1	Stuk Pièce Stück Pièce	ST010	<table border="1"> <tr><td>BR</td><td></td></tr> <tr><td>AN</td><td></td></tr> <tr><td>KL</td><td></td></tr> <tr><td>GS</td><td></td></tr> <tr><td>Z</td><td></td></tr> <tr><td>W</td><td></td></tr> </table>	BR		AN		KL		GS		Z		W	
BR																
AN																
KL																
GS																
Z																
W																
 <p>ACST020A</p> <ul style="list-style-type: none"> -Pershoek voor buitenste kamer -Clame à presser pour chambre extérieure -Eckverbinder Stanzbar für aussere kammer -Clamping corner for outside chamber <p>X=7mm Y=6mm</p>	1	Stuk Pièce Stück Pièce	ST020	<table border="1"> <tr><td>BR</td><td></td></tr> <tr><td>AN</td><td></td></tr> <tr><td>KL</td><td></td></tr> <tr><td>GS</td><td></td></tr> <tr><td>Z</td><td></td></tr> <tr><td>W</td><td></td></tr> </table>	BR		AN		KL		GS		Z		W	
BR																
AN																
KL																
GS																
Z																
W																
 <p>ACST020B</p> <ul style="list-style-type: none"> -Pershoek voor binnenste kamer -Clame à presser pour chambre intérieure -Eckverbinder Stanzbar für innere kammer -Clamping corner for inside chamber <p>X=10mm Y=31mm</p>	1	Stuk Pièce Stück Pièce	ST020	<table border="1"> <tr><td>BR</td><td></td></tr> <tr><td>AN</td><td></td></tr> <tr><td>KL</td><td></td></tr> <tr><td>GS</td><td></td></tr> <tr><td>Z</td><td></td></tr> <tr><td>W</td><td></td></tr> </table>	BR		AN		KL		GS		Z		W	
BR																
AN																
KL																
GS																
Z																
W																
 <p>ACST023A</p> <ul style="list-style-type: none"> -Lijmhoek voor buitenste kamer -Equerre de colle pour chambre extérieure -Eckverstärkung für aussere Kammer -Glue square for outside chamber <p>X=25mm Y=14mm</p>	1	Stuk Pièce Stück Pièce	ST023	<table border="1"> <tr><td>BR</td><td></td></tr> <tr><td>AN</td><td></td></tr> <tr><td>KL</td><td></td></tr> <tr><td>GS</td><td></td></tr> <tr><td>Z</td><td></td></tr> <tr><td>W</td><td></td></tr> </table>	BR		AN		KL		GS		Z		W	
BR																
AN																
KL																
GS																
Z																
W																

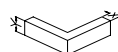

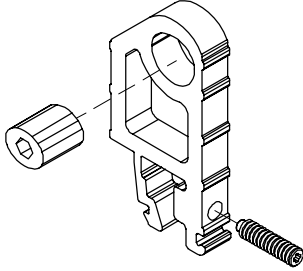
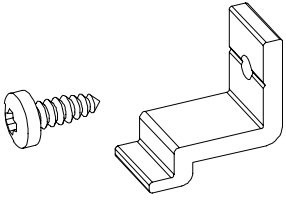
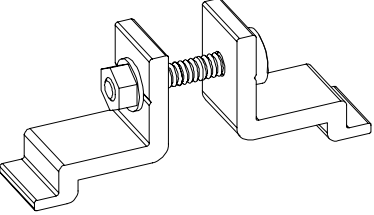
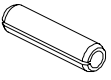
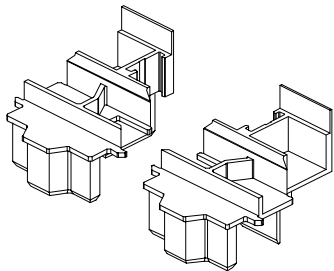
	Verp. per Emb. par Pack pr. Pack pr.	Eenheid Unité Einheit Unit	Toepassing Application Anwendung Application	Kleur Couleur Farbe Color												
 <p>ACST025 -T-verbinding -Assemblage T -T-Verbinder -Connection bracket</p> <p>X=26mm Y=7mm</p>	1	Stuk Pièce Stück Pièce	ST130 ST230 ST330	<table border="1"> <tr><td>BR</td><td></td></tr> <tr><td>AN</td><td></td></tr> <tr><td>KL</td><td></td></tr> <tr><td>GS</td><td></td></tr> <tr><td>Z</td><td></td></tr> <tr><td>W</td><td></td></tr> </table>	BR		AN		KL		GS		Z		W	
BR																
AN																
KL																
GS																
Z																
W																
 <p>ACST030 -T-verbinding -Assemblage T -T-Verbinder -Connection bracket</p>	10	Stuk Pièce Stück Pièce	ST010 ST030 ST130 ST210	<table border="1"> <tr><td>BR</td><td></td></tr> <tr><td>AN</td><td></td></tr> <tr><td>KL</td><td></td></tr> <tr><td>GS</td><td></td></tr> <tr><td>Z</td><td></td></tr> <tr><td>W</td><td></td></tr> </table>	BR		AN		KL		GS		Z		W	
BR																
AN																
KL																
GS																
Z																
W																
 <p>ACST031 -T-verbinding -Assemblage T -T-Verbinder -Connection bracket</p>	10	Stuk Pièce Stück Pièce	ST010 ST030 ST130	<table border="1"> <tr><td>BR</td><td></td></tr> <tr><td>AN</td><td></td></tr> <tr><td>KL</td><td></td></tr> <tr><td>GS</td><td></td></tr> <tr><td>Z</td><td></td></tr> <tr><td>W</td><td></td></tr> </table>	BR		AN		KL		GS		Z		W	
BR																
AN																
KL																
GS																
Z																
W																
 <p>ACST032 -Spanbus -Goupille élastique -Spannstifte -Spring type straight pin slotted</p>	100	Stuk Pièce Stück Pièce	ST030 ST130	<table border="1"> <tr><td>BR</td><td></td></tr> <tr><td>AN</td><td></td></tr> <tr><td>KL</td><td></td></tr> <tr><td>GS</td><td></td></tr> <tr><td>Z</td><td></td></tr> <tr><td>W</td><td></td></tr> </table>	BR		AN		KL		GS		Z		W	
BR																
AN																
KL																
GS																
Z																
W																
 <p>ACST054 -Stolpeindstuk -Embout maclair -Stulpendingstück -Sealing double casement</p>	1	Set	ST040	<table border="1"> <tr><td>BR</td><td></td></tr> <tr><td>AN</td><td></td></tr> <tr><td>KL</td><td></td></tr> <tr><td>GS</td><td></td></tr> <tr><td>Z</td><td>X</td></tr> <tr><td>W</td><td>X</td></tr> </table>	BR		AN		KL		GS		Z	X	W	X
BR																
AN																
KL																
GS																
Z	X															
W	X															

BR = BRUT - BRUT - ROH - BRUT
AN (X) = ANODISATIE - ANODISE - ELOXIERT - ANODISED
AN (■) = GELAKT - LAQUE - LACKIERT - LACQUERED -- RAL9006M
KL = STANDAARDKLEUREN - COULEUR STANDARD - BASIS FARBEN - BASIC COLORS
GS = GEMOFFELD SPECIAAL - LAQUE SPECIAL - SPECIALFARBE - SPECIAL COLOR
Z = ZWART - NOIR - SCHWARZ - BLACK
W = WIT - BLANC - WEISS - WHITE



GEREEDSCHAP - OUTILLAGE
WERKZEUG - TOOL



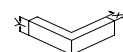

BEVESTIGING - FIXATION
BEFESTIGUNG - FIXATION

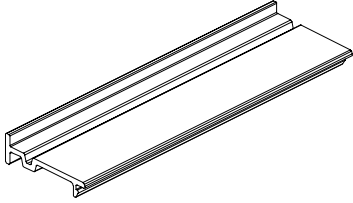
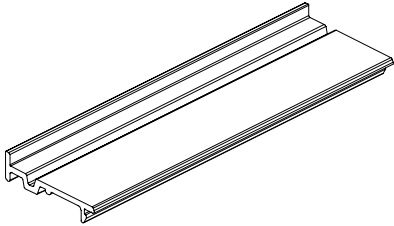
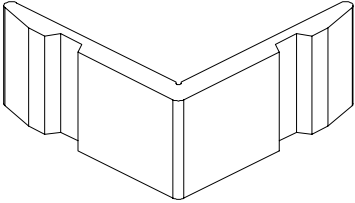
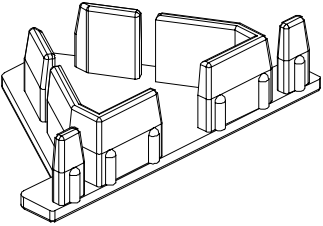
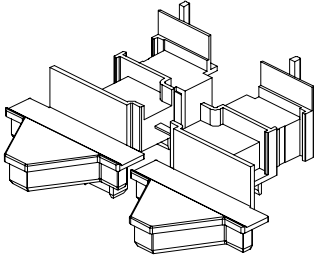

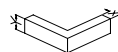
		Verp. per Emb. par Pack pr.	Einheid Unité Einheit Unit	Toepassing Application Anwendung Application	Kleur Couleur Farbe Color												
	ACST057 -Glassteun -Support cale de vitrage -Klotz-Auflage -Glazing support	1	Stuk Pièce Stück Pièce	ST010 ST020 ST030 ST120 ST130	<table border="1"> <tr><td>BR</td><td></td></tr> <tr><td>AN</td><td></td></tr> <tr><td>KL</td><td></td></tr> <tr><td>GS</td><td></td></tr> <tr><td>Z</td><td></td></tr> <tr><td>W</td><td></td></tr> </table>	BR		AN		KL		GS		Z		W	
BR																	
AN																	
KL																	
GS																	
Z																	
W																	
	ACST058 -Glassteun -Support cale de vitrage -Klotz-Auflage -Glazing support	1	Stuk Pièce Stück Pièce	ST110 ST210 ST230 ST330	<table border="1"> <tr><td>BR</td><td></td></tr> <tr><td>AN</td><td></td></tr> <tr><td>KL</td><td></td></tr> <tr><td>GS</td><td></td></tr> <tr><td>Z</td><td></td></tr> <tr><td>W</td><td></td></tr> </table>	BR		AN		KL		GS		Z		W	
BR																	
AN																	
KL																	
GS																	
Z																	
W																	
 X=7mm Y=30mm	ACST110A -Pershoek voor buitenste kamer -Clame à presser pour chambre extérieure -Eckverbinder stanbar für aussere Kammer -Clamping corner for outside chamber	1	Stuk Pièce Stück Pièce	ST110	<table border="1"> <tr><td>BR</td><td></td></tr> <tr><td>AN</td><td></td></tr> <tr><td>KL</td><td></td></tr> <tr><td>GS</td><td></td></tr> <tr><td>Z</td><td></td></tr> <tr><td>W</td><td></td></tr> </table>	BR		AN		KL		GS		Z		W	
BR																	
AN																	
KL																	
GS																	
Z																	
W																	
	ACST131 -Dop -Bouchon -Kapsel -Cap	1	Stuk Pièce Stück Pièce	ST030 ST130 ST330	<table border="1"> <tr><td>BR</td><td></td></tr> <tr><td>AN</td><td></td></tr> <tr><td>KL</td><td></td></tr> <tr><td>GS</td><td></td></tr> <tr><td>Z</td><td>X</td></tr> <tr><td>W</td><td>X</td></tr> </table>	BR		AN		KL		GS		Z	X	W	X
BR																	
AN																	
KL																	
GS																	
Z	X																
W	X																
	ACST154 -Stolpeindstuk -Embout maclair -Stulpendstück -Sealing double casement	1	Set	ST041	<table border="1"> <tr><td>BR</td><td></td></tr> <tr><td>AN</td><td></td></tr> <tr><td>KL</td><td></td></tr> <tr><td>GS</td><td></td></tr> <tr><td>Z</td><td>X</td></tr> <tr><td>W</td><td>X</td></tr> </table>	BR		AN		KL		GS		Z	X	W	X
BR																	
AN																	
KL																	
GS																	
Z	X																
W	X																

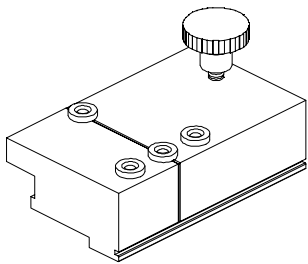
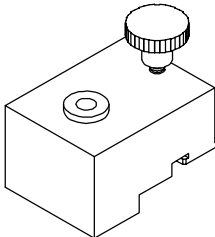
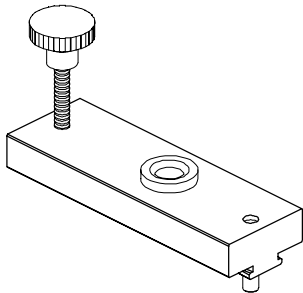

		Verp. per Emb. par Pack pr. Pack pr.	Eenheid Unité Einheit Unit	Toepassing Application Anwendung Application	Kleur Couleur Farbe Color												
	ACST900 -Boormal -Calibre -Bohrschablone -Boring jig set	1	Stuk Pièce Stück Piece	ST010 ST030	<table border="1"> <tr><td>BR</td><td></td></tr> <tr><td>AN</td><td></td></tr> <tr><td>KL</td><td></td></tr> <tr><td>GS</td><td></td></tr> <tr><td>Z</td><td></td></tr> <tr><td>W</td><td></td></tr> </table>	BR		AN		KL		GS		Z		W	
BR																	
AN																	
KL																	
GS																	
Z																	
W																	
	ACST901 -Boormal voor watergat -Calibre pour écoulement d'eau -Bohrschablone für entwässerung -Boring jet set for drain hole	1	Stuk Pièce Stück Piece	ST020	<table border="1"> <tr><td>BR</td><td></td></tr> <tr><td>AN</td><td></td></tr> <tr><td>KL</td><td></td></tr> <tr><td>GS</td><td></td></tr> <tr><td>Z</td><td></td></tr> <tr><td>W</td><td></td></tr> </table>	BR		AN		KL		GS		Z		W	
BR																	
AN																	
KL																	
GS																	
Z																	
W																	
	ACST925 -Boormal -Calibre -Bohrschablone -Boring jet set	1	Stuk Pièce Stück Piece	ACST025	<table border="1"> <tr><td>BR</td><td></td></tr> <tr><td>AN</td><td></td></tr> <tr><td>KL</td><td></td></tr> <tr><td>GS</td><td></td></tr> <tr><td>Z</td><td></td></tr> <tr><td>W</td><td></td></tr> </table>	BR		AN		KL		GS		Z		W	
BR																	
AN																	
KL																	
GS																	
Z																	
W																	
	ACDR052 -Inox schroef DIN7981 4.8x50 -Vis DIN7981 4.8x50 -Schraube DIN7981 4.8x50 -Screw DIN7981 4.8x50	200	Stuk Pièce Stück Piece	ST010 ST030	<table border="1"> <tr><td>BR</td><td></td></tr> <tr><td>AN</td><td></td></tr> <tr><td>KL</td><td></td></tr> <tr><td>GS</td><td></td></tr> <tr><td>Z</td><td></td></tr> <tr><td>W</td><td></td></tr> </table>	BR		AN		KL		GS		Z		W	
BR																	
AN																	
KL																	
GS																	
Z																	
W																	
 X=15mm Y=18mm	ACDV12 -Pershoek voor binnenste kamer -Clame à presser pour chambre intérieure -Eckverbinder stanbar für innere kammer -Clamping corner for inside chamber	1 24	Stuk Pièce Stück Piece	TL218	<table border="1"> <tr><td>BR</td><td></td></tr> <tr><td>AN</td><td></td></tr> <tr><td>KL</td><td></td></tr> <tr><td>GS</td><td></td></tr> <tr><td>Z</td><td></td></tr> <tr><td>W</td><td></td></tr> </table>	BR		AN		KL		GS		Z		W	
BR																	
AN																	
KL																	
GS																	
Z																	
W																	





BR = BRUT - BRUT - ROH - BRUT
AN (X) = ANODISATIE - ANODISE - ELOXIERT - ANODISED
AN (■) = GELAKT - LAQUE - LACKIERT - LACQUERED -- RAL9006M
KL = STANDAARDKLEUREN - COULEUR STANDARD - BASIS FARBEN - BASIC COLORS
GS = GEMOFFELD SPECIAAL - LAQUE SPECIAL - SPECIALFARBE - SPECIAL COLOR
Z = ZWART - NOIR - SCHWARZ - BLACK
W = WIT - BLANC - WEISS - WHITE



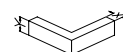

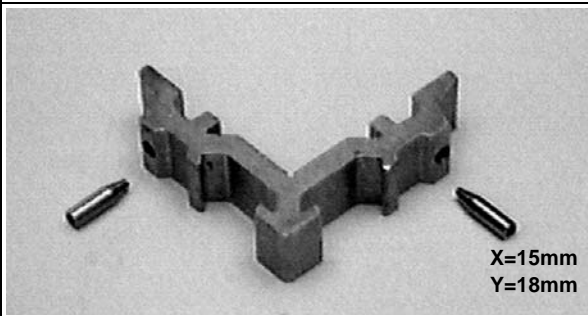

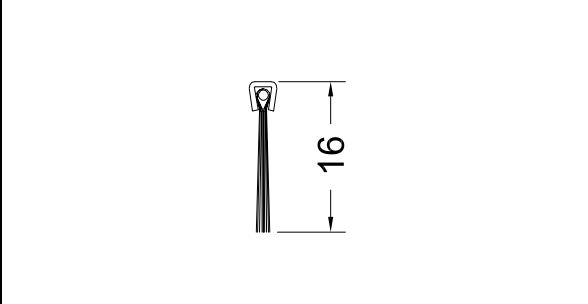
GEREEDSCHAP - OUTILLAGE
WERKZEUG - TOOL

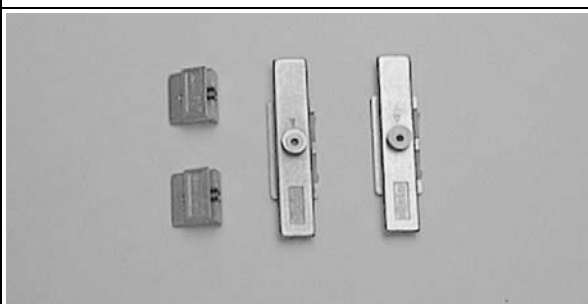
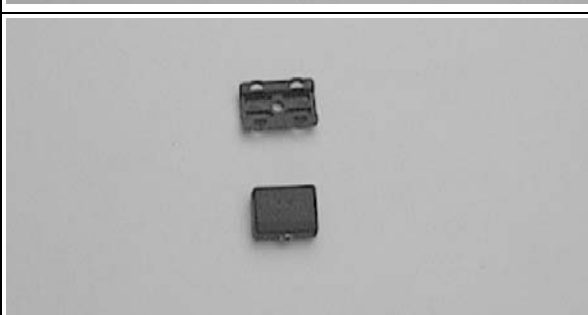
BEVESTIGING - FIXATION
BEFESTIGUNG - FIXATION

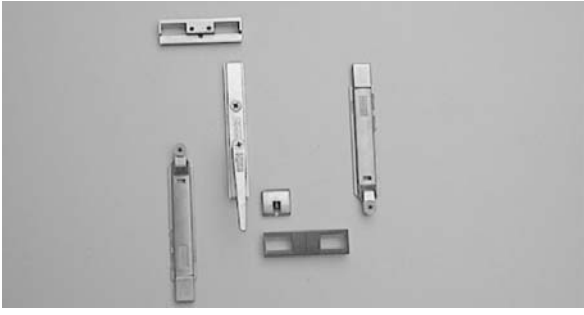

	Verp. per Emb. par Pack pr.	Einheid Unité Einheit Unit	Toepassing Application Anwendung Application	Kleur Couleur Farbe Color												
 <p>ACDV13 -Stifhoek voor binnenste kamer -Clame à goupiller pour chambre intérieure -Eckverbinder verstiftet für innere kammer -Square bracket for inside chamber</p> <p>X=15mm Y=18mm</p> <p> ACDV235</p>	1 24	Stuk Pièce Stück Pièce	TL218	<table border="1"> <tr><td>BR</td><td></td></tr> <tr><td>AN</td><td></td></tr> <tr><td>KL</td><td></td></tr> <tr><td>GS</td><td></td></tr> <tr><td>Z</td><td></td></tr> <tr><td>W</td><td></td></tr> </table>	BR		AN		KL		GS		Z		W	
BR																
AN																
KL																
GS																
Z																
W																
 <p>ACDV201 -Borsteldichting onderkant deur -Brosse desous de porte -Bursten dichtung für türen -Sill gasket</p>	3	m	TL055	<table border="1"> <tr><td>BR</td><td></td></tr> <tr><td>AN</td><td></td></tr> <tr><td>KL</td><td></td></tr> <tr><td>GS</td><td></td></tr> <tr><td>Z</td><td></td></tr> <tr><td>W</td><td></td></tr> </table>	BR		AN		KL		GS		Z		W	
BR																
AN																
KL																
GS																
Z																
W																
 <p>ACFA042 -Bijkomend sluitpunt "H" O.R. -Point de verrouillage sup "H" O.F. -Mittelverschluss "H" D.F. - Adjusting lock plate "H" C.W.</p>	1 50	Stuk Pièce Stück Pièce		<table border="1"> <tr><td>BR</td><td>X</td></tr> <tr><td>AN</td><td></td></tr> <tr><td>KL</td><td></td></tr> <tr><td>GS</td><td></td></tr> <tr><td>Z</td><td></td></tr> <tr><td>W</td><td></td></tr> </table>	BR	X	AN		KL		GS		Z		W	
BR	X															
AN																
KL																
GS																
Z																
W																
 <p>ACFA050 -Set sluitpunten onder + boven OR -Points de verrouillage sup. + inf. OF -Riegelstücke zum einklemmen DF -Adjusting lock plates CV</p>	1 50	Stuk Pièce Stück Pièce		<table border="1"> <tr><td>BR</td><td>X</td></tr> <tr><td>AN</td><td></td></tr> <tr><td>KL</td><td></td></tr> <tr><td>GS</td><td></td></tr> <tr><td>Z</td><td></td></tr> <tr><td>W</td><td></td></tr> </table>	BR	X	AN		KL		GS		Z		W	
BR	X															
AN																
KL																
GS																
Z																
W																
 <p>ACFA051 -Oplooblokje -Patin -Auflaufstück -Sloped block</p>	1 50	Stuk Pièce Stück Pièce		<table border="1"> <tr><td>BR</td><td>X</td></tr> <tr><td>AN</td><td></td></tr> <tr><td>KL</td><td></td></tr> <tr><td>GS</td><td></td></tr> <tr><td>Z</td><td></td></tr> <tr><td>W</td><td></td></tr> </table>	BR	X	AN		KL		GS		Z		W	
BR	X															
AN																
KL																
GS																
Z																
W																

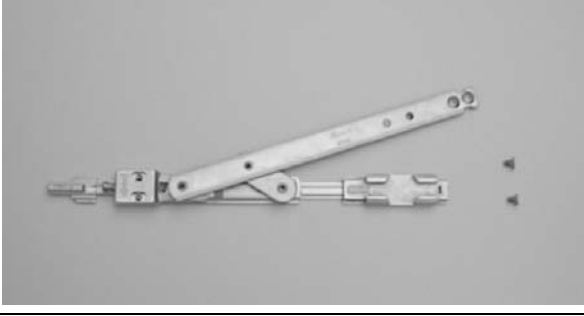

		Verp. per Emb. par Pack pr. Pack pr.	Eenheid Unité Einheit Unit	Toepassing Application Anwendung Application	Kleur Couleur Farbe Color												
	ACFA055 -Stolpsluiting dubbele vleugel -Verrouillage double ouvrant -Zentralverschluss stulpfenster -Central closure double casement	1 10	Stuk Pièce Stück Pièce		<table border="1"> <tr><td>BR</td><td>X</td></tr> <tr><td>AN</td><td></td></tr> <tr><td>KL</td><td></td></tr> <tr><td>GS</td><td></td></tr> <tr><td>Z</td><td></td></tr> <tr><td>W</td><td></td></tr> </table>	BR	X	AN		KL		GS		Z		W	
BR	X																
AN																	
KL																	
GS																	
Z																	
W																	
	ACFA056 -Stolpsluiting dubbele vleugel met bijkomend sluitp "B" -Verrouillage double ouvrant avec point de v. sup "L" -Zentralverschluss stulpfenster mit mittelv "B" -Central closure double casement with adj. lockpl. "W"	1 10	Stuk Pièce Stück Pièce		<table border="1"> <tr><td>BR</td><td>X</td></tr> <tr><td>AN</td><td></td></tr> <tr><td>KL</td><td></td></tr> <tr><td>GS</td><td></td></tr> <tr><td>Z</td><td></td></tr> <tr><td>W</td><td></td></tr> </table>	BR	X	AN		KL		GS		Z		W	
BR	X																
AN																	
KL																	
GS																	
Z																	
W																	
	ACFA061 -Schaar kipdraai 402-750mm -Compas manoeuvre logique 402-750mm -Axeer kiepdreh 402-750mm -Arms for tilt befor turn 402-750mm	1 10	Stuk Pièce Stück Pièce		<table border="1"> <tr><td>BR</td><td>X</td></tr> <tr><td>AN</td><td></td></tr> <tr><td>KL</td><td></td></tr> <tr><td>GS</td><td></td></tr> <tr><td>Z</td><td></td></tr> <tr><td>W</td><td></td></tr> </table>	BR	X	AN		KL		GS		Z		W	
BR	X																
AN																	
KL																	
GS																	
Z																	
W																	
	ACFA062 -Schaar kipdraai 562-1200mm -Compas manoeuvre logique 562-1200mm -Axeer kiepdreh 562-1200mm -Arms for tilt befor turn 562-1200mm	1 10	Stuk Pièce Stück Pièce		<table border="1"> <tr><td>BR</td><td>X</td></tr> <tr><td>AN</td><td></td></tr> <tr><td>KL</td><td></td></tr> <tr><td>GS</td><td></td></tr> <tr><td>Z</td><td></td></tr> <tr><td>W</td><td></td></tr> </table>	BR	X	AN		KL		GS		Z		W	
BR	X																
AN																	
KL																	
GS																	
Z																	
W																	
	ACFA063 -Schaar kipdraai 816-1700mm -Compas manoeuvre logique 816-1700mm -Axeer kiepdreh 816-1700mm -Arms for tilt befor turn 816-1700mm	1 10	Stuk Pièce Stück Pièce		<table border="1"> <tr><td>BR</td><td>X</td></tr> <tr><td>AN</td><td></td></tr> <tr><td>KL</td><td></td></tr> <tr><td>GS</td><td></td></tr> <tr><td>Z</td><td></td></tr> <tr><td>W</td><td></td></tr> </table>	BR	X	AN		KL		GS		Z		W	
BR	X																
AN																	
KL																	
GS																	
Z																	
W																	

BR = BRUT - BRUT - ROH - BRUT

AN (X) = ANODISATIE - ANODISE - ELOXIERT - ANODISED

AN () = GELAKT - LAQUE - LACKIERT - LACQUERED -- RAL9006M

KL = STANDAARDKLEUREN - COULEUR STANDARD - BASIS FARBEN - BASIC COLORS

GS = GEMOFFELD SPECIAAL - LAQUE SPECIAL - SPECIALFARBE - SPECIAL COLOR

Z = ZWART - NOIR - SCHWARZ - BLACK

W = WIT - BLANC - WEISS - WHITE

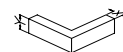
GEREEDSCHAP - OUTILLAGE
WERKZEUG - TOOLBEVESTIGING - FIXATION
BEFESTIGUNG - FIXATION

	Verp. per Emb. par Pack pr.	Einheid Unité Einheit Unit	Toepassing Application Anwendung Application	Kleur Couleur Farbe Color												
 <p>ACFA065</p> <ul style="list-style-type: none"> -Bijkomend sluitpunt breedte voor kipdraai -Verrouillage sup. L pour manoeuvre logique -Mittelverschluss B fur kipdreh -Additional lock point W for tilt befor turn 	1	Stuk Pièce Stück Piece		<table border="1"> <tr><td>BR</td><td>X</td></tr> <tr><td>AN</td><td></td></tr> <tr><td>KL</td><td></td></tr> <tr><td>GS</td><td></td></tr> <tr><td>Z</td><td></td></tr> <tr><td>W</td><td></td></tr> </table>	BR	X	AN		KL		GS		Z		W	
BR	X															
AN																
KL																
GS																
Z																
W																
 <p>ACFA069</p> <ul style="list-style-type: none"> -Inklembaar kipdraai basiskarton -Garniture de base manoeuvre logique encas-trable -Klembar kipdreh grundausrstattung -Concealed tilt befor turn basic parts <p>MAX 130kg</p>	1 10	Stuk Pièce Stück Piece		<table border="1"> <tr><td>BR</td><td>X</td></tr> <tr><td>AN</td><td></td></tr> <tr><td>KL</td><td>X</td></tr> <tr><td>GS</td><td>X</td></tr> <tr><td>Z</td><td>X</td></tr> <tr><td>W</td><td>X</td></tr> </table>	BR	X	AN		KL	X	GS	X	Z	X	W	X
BR	X															
AN																
KL	X															
GS	X															
Z	X															
W	X															
 <p>ACFA070</p> <ul style="list-style-type: none"> -Inklembaar draaikip basiskarton -Garniture de base ob encastrable -Klembar drehk. grundausrstattung -Concealed turn and tilt basic parts <p>MAX 130kg</p>	1 10	Stuk Pièce Stück Piece		<table border="1"> <tr><td>BR</td><td>X</td></tr> <tr><td>AN</td><td></td></tr> <tr><td>KL</td><td>X</td></tr> <tr><td>GS</td><td>X</td></tr> <tr><td>Z</td><td>X</td></tr> <tr><td>W</td><td>X</td></tr> </table>	BR	X	AN		KL	X	GS	X	Z	X	W	X
BR	X															
AN																
KL	X															
GS	X															
Z	X															
W	X															
 <p>ACFA071</p> <ul style="list-style-type: none"> -Valschaar DK - 402 - 750 mm -Compas OB - 402 - 750 mm -Axer DK -402 - 750 mm -Arms TT -402 - 750 mm 	1 10	Stuk Pièce Stück Piece	ACFA070	<table border="1"> <tr><td>BR</td><td>X</td></tr> <tr><td>AN</td><td></td></tr> <tr><td>KL</td><td></td></tr> <tr><td>GS</td><td></td></tr> <tr><td>Z</td><td></td></tr> <tr><td>W</td><td></td></tr> </table>	BR	X	AN		KL		GS		Z		W	
BR	X															
AN																
KL																
GS																
Z																
W																
 <p>ACFA072</p> <ul style="list-style-type: none"> -Valschaar DK - 562-1200 mm -Compas OB - 562-1200 mm -Axer DK -562-1200 mm -Arms TT -562-1200 mm 	1 10	Stuk Pièce Stück Piece	ACFA070	<table border="1"> <tr><td>BR</td><td>X</td></tr> <tr><td>AN</td><td></td></tr> <tr><td>KL</td><td></td></tr> <tr><td>GS</td><td></td></tr> <tr><td>Z</td><td></td></tr> <tr><td>W</td><td></td></tr> </table>	BR	X	AN		KL		GS		Z		W	
BR	X															
AN																
KL																
GS																
Z																
W																

BR = BRUT - BRUT - ROH - BRUT
 AN (X) = ANODISATIE - ANODISE - ELOXIERT - ANODISED
 AN (■) = GELAKT - LAQUE - LACKIERT - LACQUERED -- RAL9006M
 KL = STANDAARDKLEUREN - COULEUR STANDARD - BASIS FARBEN - BASIC COLORS
 GS = GEMOFFELD SPECIAAL - LAQUE SPECIAL - SPECIALFARBE - SPECIAL COLOR
 Z = ZWART - NOIR - SCHWARZ - BLACK
 W = WIT - BLANC - WEISS - WHITE







GEREEDSCHAP - OUTILLAGE
WERKZEUG - TOOL

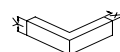

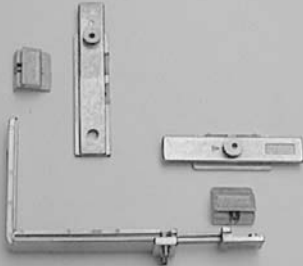

BEVESTIGING - FIXATION
BEFESTIGUNG - FIXATION



		Verp. per Emb. par Pack pr. Pack pr.	Eenheid Unité Einheit Unit	Toepassing Application Anwendung Application	Kleur Couleur Farbe Color												
	ACFA073 -Valschaar DK - 816 - 1700 mm -Compas OB - 816 - 1700 mm -Axe DK - 816 - 1700 mm -Arms TT - 816 - 1700 mm	1 10	Stuk Pièce Stück Pièce	ACFA070	<table border="1"> <tr><td>BR</td><td>X</td></tr> <tr><td>AN</td><td></td></tr> <tr><td>KL</td><td></td></tr> <tr><td>GS</td><td></td></tr> <tr><td>Z</td><td></td></tr> <tr><td>W</td><td></td></tr> </table>	BR	X	AN		KL		GS		Z		W	
BR	X																
AN																	
KL																	
GS																	
Z																	
W																	
	ACFA078 -Bijkomend sluitpunt "H" -Point de verrouillage sup "H" -Mittelschloss "H" -Additional lock point "H"	1 50	Stuk Pièce Stück Pièce	ACFA070	<table border="1"> <tr><td>BR</td><td>X</td></tr> <tr><td>AN</td><td></td></tr> <tr><td>KL</td><td></td></tr> <tr><td>GS</td><td></td></tr> <tr><td>Z</td><td></td></tr> <tr><td>W</td><td></td></tr> </table>	BR	X	AN		KL		GS		Z		W	
BR	X																
AN																	
KL																	
GS																	
Z																	
W																	
	ACFA079 -Bijkomend sluitpunt D.K. "B" -Point de verrouillage sup. O.B. "B" -Mittelschuss D.K. "B" -Additional lock point T.T. "B"	1 50	Stuk Pièce Stück Pièce	ACFA070	<table border="1"> <tr><td>BR</td><td>X</td></tr> <tr><td>AN</td><td></td></tr> <tr><td>KL</td><td></td></tr> <tr><td>GS</td><td></td></tr> <tr><td>Z</td><td></td></tr> <tr><td>W</td><td></td></tr> </table>	BR	X	AN		KL		GS		Z		W	
BR	X																
AN																	
KL																	
GS																	
Z																	
W																	
	ACFA081 -Kruk draaikipbeslag -Cremone O.B. -Umschaltgetriebe D.K. -Handle turn and tilt	1 10	Stuk Pièce Stück Pièce	ST020	<table border="1"> <tr><td>BR</td><td></td></tr> <tr><td>AN</td><td>■</td></tr> <tr><td>KL</td><td>X</td></tr> <tr><td>GS</td><td>X</td></tr> <tr><td>Z</td><td>X</td></tr> <tr><td>W</td><td>X</td></tr> </table>	BR		AN	■	KL	X	GS	X	Z	X	W	X
BR																	
AN	■																
KL	X																
GS	X																
Z	X																
W	X																
	ACFA082 -Raamkruk met cilinder voor kipdraai -Cremone avec cylindre pour manoeuvre logique -Umschaltgetriebe mit zylinder fur kippdreh -Handle turn and tilt with cylinder tilt before turn	1 10	Stuk Pièce Stück Pièce	ST020	<table border="1"> <tr><td>BR</td><td></td></tr> <tr><td>AN</td><td>■</td></tr> <tr><td>KL</td><td>X</td></tr> <tr><td>GS</td><td>X</td></tr> <tr><td>Z</td><td>X</td></tr> <tr><td>W</td><td>X</td></tr> </table>	BR		AN	■	KL	X	GS	X	Z	X	W	X
BR																	
AN	■																
KL	X																
GS	X																
Z	X																
W	X																





BR = BRUT - BRUT - ROH - BRUT
AN (X) = ANODISATIE - ANODISE - ELOXIERT - ANODISED
AN (■) = GELAKT - LAQUE - LACKIERT - LACQUERED -- RAL9006M
KL = STANDAARDKLEUREN - COULEUR STANDARD - BASIS FARBEN - BASIC COLORS
GS = GEMOFFELD SPECIAAL - LAQUE SPECIAL - SPECIALFARBE - SPECIAL COLOR
Z = ZWART - NOIR - SCHWARZ - BLACK
W = WIT - BLANC - WEISS - WHITE

 GEREEDSCHAP - OUTILLAGE
WERKZEUG - TOOL
 BEVESTIGING - FIXATION
BEFESTIGUNG - FIXATION

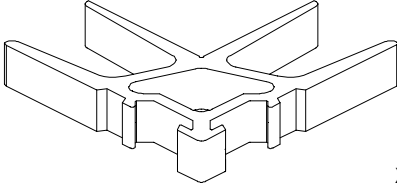
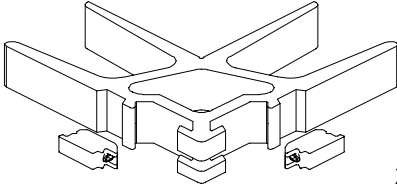

	Verp. per Emb. par Pack pr.	Einheid Unité Einheit Unit	Toepassing Application Anwendung Application	Kleur Couleur Farbe Color												
 <p>ACFA083 -Meeneemstuk voor draaikruk -Piese d'entrainement ob -Kupplungslasche dk -Connection piece TT</p>	1 10	Stuk Pièce Stück Piece		<table border="1"> <tr><td>BR</td><td></td></tr> <tr><td>AN</td><td></td></tr> <tr><td>KL</td><td></td></tr> <tr><td>GS</td><td></td></tr> <tr><td>Z</td><td></td></tr> <tr><td>W</td><td></td></tr> </table>	BR		AN		KL		GS		Z		W	
BR																
AN																
KL																
GS																
Z																
W																
 <p>ACFA084 -Raamkruk met cilinder -Cremone avec cylindre -Umschaltgetriebe mit zylinder -Handle with cylinder</p>	1 10	Stuk Pièce Stück Piece	ST020	<table border="1"> <tr><td>BR</td><td></td></tr> <tr><td>AN</td><td>■</td></tr> <tr><td>KL</td><td>X</td></tr> <tr><td>GS</td><td>X</td></tr> <tr><td>Z</td><td>X</td></tr> <tr><td>W</td><td>X</td></tr> </table>	BR		AN	■	KL	X	GS	X	Z	X	W	X
BR																
AN	■															
KL	X															
GS	X															
Z	X															
W	X															
 <p>ACFA087 -Bijkomende valschaar 1200mm-1700mm -Compas compl. ob 1200mm-1700mm -Zusatzschere dk 1200mm-1700mm -Belonging arms TT 1200mm-1700mm</p>	1 10	Stuk Pièce Stück Piece		<table border="1"> <tr><td>BR</td><td>X</td></tr> <tr><td>AN</td><td>X</td></tr> <tr><td>KL</td><td>X</td></tr> <tr><td>GS</td><td>X</td></tr> <tr><td>Z</td><td>X</td></tr> <tr><td>W</td><td>X</td></tr> </table>	BR	X	AN	X	KL	X	GS	X	Z	X	W	X
BR	X															
AN	X															
KL	X															
GS	X															
Z	X															
W	X															
 <p>ACFA120 -Deurkruk -Bequille de porte -Turgriff -Doorhandle</p>	1	Stuk Pièce Stück Piece	ST023	<table border="1"> <tr><td>BR</td><td></td></tr> <tr><td>AN</td><td>■</td></tr> <tr><td>KL</td><td>X</td></tr> <tr><td>GS</td><td>X</td></tr> <tr><td>Z</td><td>X</td></tr> <tr><td>W</td><td>X</td></tr> </table>	BR		AN	■	KL	X	GS	X	Z	X	W	X
BR																
AN	■															
KL	X															
GS	X															
Z	X															
W	X															
 <p>ACFA121 -Bevestigingsblokje -Bloc de fixation -Befestigungsblock -Fixation block</p> <p style="font-size: 2em; font-weight: bold;">X 10</p>	1	Zakje Sachet Beutel Pack	ACFA120	<table border="1"> <tr><td>BR</td><td></td></tr> <tr><td>AN</td><td></td></tr> <tr><td>KL</td><td></td></tr> <tr><td>GS</td><td></td></tr> <tr><td>Z</td><td></td></tr> <tr><td>W</td><td></td></tr> </table>	BR		AN		KL		GS		Z		W	
BR																
AN																
KL																
GS																
Z																
W																



		Verp. per Emb. par Pack pr. Pack pr.	Eenheid Unité Einheit Unit	Toepassing Application Anwendung Application	Kleur Couleur Farbe Color												
 <p>ACIP016B -Pershoek voor binnenste kamer -Clame à presser pour chambre intérieure -Eckverbinder stanbaar für innere Kammer -Clamping corner for inside chamber</p> <p>X=41mm Y=28mm</p>		1 24	Stuk Pièce Stück Pièce	ST023	<table border="1"> <tr><td>BR</td><td></td></tr> <tr><td>AN</td><td></td></tr> <tr><td>KL</td><td></td></tr> <tr><td>GS</td><td></td></tr> <tr><td>Z</td><td></td></tr> <tr><td>W</td><td></td></tr> </table>	BR		AN		KL		GS		Z		W	
BR																	
AN																	
KL																	
GS																	
Z																	
W																	
 <p>ACIP017B -Schroefhoek voor binnenste kamer -Clame à visser pour chambre intérieure -Eckverbinder schraubbar für innere Kammer -Square coupling joint for inside chamber</p> <p>X=41mm Y=28mm</p>  ACVG66		1 48	Stuk Pièce Stück Pièce	ST023	<table border="1"> <tr><td>BR</td><td></td></tr> <tr><td>AN</td><td></td></tr> <tr><td>KL</td><td></td></tr> <tr><td>GS</td><td></td></tr> <tr><td>Z</td><td></td></tr> <tr><td>W</td><td></td></tr> </table>	BR		AN		KL		GS		Z		W	
BR																	
AN																	
KL																	
GS																	
Z																	
W																	
 <p>ACIP146 -Automatische tochttafsluiter 710mm -Joint bas de porte automatique 710mm -Automatische turdichtung 710mm -Self operating threshold 710mm</p>		1	Stuk Pièce Stück Pièce	ST023	<table border="1"> <tr><td>BR</td><td></td></tr> <tr><td>AN</td><td></td></tr> <tr><td>KL</td><td></td></tr> <tr><td>GS</td><td></td></tr> <tr><td>Z</td><td></td></tr> <tr><td>W</td><td></td></tr> </table>	BR		AN		KL		GS		Z		W	
BR																	
AN																	
KL																	
GS																	
Z																	
W																	
 <p>ACIP147 -Automatische tochttafsluiter 835mm -Joint bas de porte automatique 835mm -Automatische turdichtung 835mm -Self operating threshold 835mm</p>		1	Stuk Pièce Stück Pièce	ST023	<table border="1"> <tr><td>BR</td><td></td></tr> <tr><td>AN</td><td></td></tr> <tr><td>KL</td><td></td></tr> <tr><td>GS</td><td></td></tr> <tr><td>Z</td><td></td></tr> <tr><td>W</td><td></td></tr> </table>	BR		AN		KL		GS		Z		W	
BR																	
AN																	
KL																	
GS																	
Z																	
W																	
 <p>ACIP148 -Automatische tochttafsluiter 960mm -Joint bas de porte automatique 960mm -Automatische turdichtung 960mm -Self operating threshold 960mm</p>		1	Stuk Pièce Stück Pièce	ST023	<table border="1"> <tr><td>BR</td><td></td></tr> <tr><td>AN</td><td></td></tr> <tr><td>KL</td><td></td></tr> <tr><td>GS</td><td></td></tr> <tr><td>Z</td><td></td></tr> <tr><td>W</td><td></td></tr> </table>	BR		AN		KL		GS		Z		W	
BR																	
AN																	
KL																	
GS																	
Z																	
W																	

BR = BRUT - BRUT - ROH - BRUT
AN (X) = ANODISATIE - ANODISE - ELOXIERT - ANODISED
AN (■) = GELAKT - LAQUE - LACKIERT - LACQUERED -- RAL9006M
KL = STANDAARDKLEUREN - COULEUR STANDARD - BASIS FARBEN - BASIC COLORS
GS = GEMOFFELD SPECIAAL - LAQUE SPECIAL - SPECIALFARBE - SPECIAL COLOR
Z = ZWART - NOIR - SCHWARZ - BLACK
W = WIT - BLANC - WEISS - WHITE



GEREEDSCHAP - OUTILLAGE
WERKZEUG - TOOL



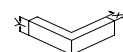

BEVESTIGING - FIXATION
BEFESTIGUNG - FIXATION

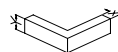

	Verp. per Emb. par Pack pr.	Einheid Unit	Toepassing Application	Kleur Couleur Farbe Color												
 <p>ACIP149 -Automatische tochtsluiser 1085mm -Joint bas de porte automatique 1085mm -Automatische turdichtung 1085mm -Self operating threshold 1085mm</p>	1	Stuk Pièce Stück Piece	ST023	<table border="1"> <tr><td>BR</td><td></td></tr> <tr><td>AN</td><td></td></tr> <tr><td>KL</td><td></td></tr> <tr><td>GS</td><td></td></tr> <tr><td>Z</td><td></td></tr> <tr><td>W</td><td></td></tr> </table>	BR		AN		KL		GS		Z		W	
BR																
AN																
KL																
GS																
Z																
W																
 <p>ACIP427 -Bodemhuls verzinkt -Douille de sol galvanisé -Bodenbüchse verzinkt -Ground sleeve zinc-plate</p>	1	Stuk Pièce Stück Piece	ACVL432	<table border="1"> <tr><td>BR</td><td></td></tr> <tr><td>AN</td><td></td></tr> <tr><td>KL</td><td></td></tr> <tr><td>GS</td><td></td></tr> <tr><td>Z</td><td></td></tr> <tr><td>W</td><td></td></tr> </table>	BR		AN		KL		GS		Z		W	
BR																
AN																
KL																
GS																
Z																
W																
 <p>ACMX040 -Scharnier -Paumelle -Band -Hinge</p>	1	Stuk Pièce Stück Piece	ST020	<table border="1"> <tr><td>BR</td><td>X</td></tr> <tr><td>AN</td><td>X</td></tr> <tr><td>KL</td><td>X</td></tr> <tr><td>GS</td><td>X</td></tr> <tr><td>Z</td><td>X</td></tr> <tr><td>W</td><td>X</td></tr> </table>	BR	X	AN	X	KL	X	GS	X	Z	X	W	X
BR	X															
AN	X															
KL	X															
GS	X															
Z	X															
W	X															
 <p>ACMX053 -Inklembare valschaar r.v.s. -Patin en nylon -Auflaufstück kunststoff -Sloped nylon block</p>	1	Set		<table border="1"> <tr><td>BR</td><td></td></tr> <tr><td>AN</td><td></td></tr> <tr><td>KL</td><td></td></tr> <tr><td>GS</td><td></td></tr> <tr><td>Z</td><td>X</td></tr> <tr><td>W</td><td></td></tr> </table>	BR		AN		KL		GS		Z	X	W	
BR																
AN																
KL																
GS																
Z	X															
W																
 <p>ACMX100 -Scharnier -Paumelle -Scharnier -Hinge</p>	1	Stuk Pièce Stück Piece	ST010 ST020 ST030 ST130	<table border="1"> <tr><td>BR</td><td>X</td></tr> <tr><td>AN</td><td>X</td></tr> <tr><td>KL</td><td>X</td></tr> <tr><td>GS</td><td>X</td></tr> <tr><td>Z</td><td>X</td></tr> <tr><td>W</td><td>X</td></tr> </table>	BR	X	AN	X	KL	X	GS	X	Z	X	W	X
BR	X															
AN	X															
KL	X															
GS	X															
Z	X															
W	X															

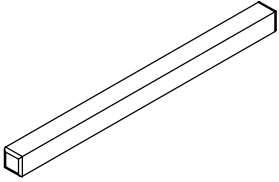
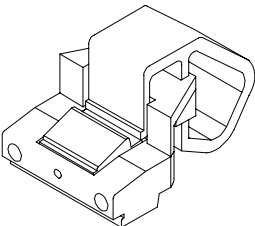

		Verp. per Emb. par Pack pr. Pack pr.	Eenheid Unité Einheit Unit	Toepassing Application Anwendung Application	Kleur Couleur Farbe Color												
	ACMX102 -Inkleembaar deurscharnier -Charnière de porte encastrable -Klembaar Türband -Doorhinge clampable	1	Stuk Pièce Stück Pièce	ST023	<table border="1"> <tr><td>BR</td><td>X</td></tr> <tr><td>AN</td><td>X</td></tr> <tr><td>KL</td><td>X</td></tr> <tr><td>GS</td><td>X</td></tr> <tr><td>Z</td><td>X</td></tr> <tr><td>W</td><td>X</td></tr> </table>	BR	X	AN	X	KL	X	GS	X	Z	X	W	X
BR	X																
AN	X																
KL	X																
GS	X																
Z	X																
W	X																
	ACMX208 -Veiligheidscilinderplaatje -Cache cylindre de sécurité -Sicherheits Zylinder Rosette -Safety cover for lock h = 10mm	1	Stuk Pièce Stück Pièce		<table border="1"> <tr><td>BR</td><td>X</td></tr> <tr><td>AN</td><td>X</td></tr> <tr><td>KL</td><td>X</td></tr> <tr><td>GS</td><td>X</td></tr> <tr><td>Z</td><td>X</td></tr> <tr><td>W</td><td>X</td></tr> </table>	BR	X	AN	X	KL	X	GS	X	Z	X	W	X
BR	X																
AN	X																
KL	X																
GS	X																
Z	X																
W	X																
	ACMX208S -Veiligheidscilinderplaatje -Cache cylindre de sécurité -Sicherheits Zylinder Rosette -Safety cover for lock h = 10mm	1	Stuk Pièce Stück Pièce		<table border="1"> <tr><td>BR</td><td>X</td></tr> <tr><td>AN</td><td>X</td></tr> <tr><td>KL</td><td>X</td></tr> <tr><td>GS</td><td>X</td></tr> <tr><td>Z</td><td>X</td></tr> <tr><td>W</td><td>X</td></tr> </table>	BR	X	AN	X	KL	X	GS	X	Z	X	W	X
BR	X																
AN	X																
KL	X																
GS	X																
Z	X																
W	X																
	ACMX209 -Stift 120X8X8mm -Goupille 120X8X8mm -Weschelstift 120X8X8mm -Change rod 120X8X8mm	1	Stuk Pièce Stück Pièce	ACFA120	<table border="1"> <tr><td>BR</td><td></td></tr> <tr><td>AN</td><td></td></tr> <tr><td>KL</td><td></td></tr> <tr><td>GS</td><td></td></tr> <tr><td>Z</td><td></td></tr> <tr><td>W</td><td></td></tr> </table>	BR		AN		KL		GS		Z		W	
BR																	
AN																	
KL																	
GS																	
Z																	
W																	
	ACMX252 -Knipluiking -Loqueteau -Oberlichtschnapper -Springlatch	1	Stuk Pièce Stück Pièce	ST010 ST020 ST030 ST130	<table border="1"> <tr><td>BR</td><td></td></tr> <tr><td>AN</td><td></td></tr> <tr><td>KL</td><td></td></tr> <tr><td>GS</td><td></td></tr> <tr><td>Z</td><td>X</td></tr> <tr><td>W</td><td>X</td></tr> </table>	BR		AN		KL		GS		Z	X	W	X
BR																	
AN																	
KL																	
GS																	
Z	X																
W	X																

BR = BRUT - BRUT - ROH - BRUT
AN (X) = ANODISATIE - ANODISE - ELOXIERT - ANODISED
AN (■) = GELAKT - LAQUE - LACKIERT - LACQUERED -- RAL9006M
KL = STANDAARDKLEUREN - COULEUR STANDARD - BASIS FARBEN - BASIC COLORS
GS = GEMOFFELD SPECIAAL - LAQUE SPECIAL - SPECIALFARBE - SPECIAL COLOR
Z = ZWART - NOIR - SCHWARZ - BLACK
W = WIT - BLANC - WEISS - WHITE





GEREEDSCHAP - OUTILLAGE
WERKZEUG - TOOL

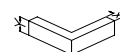

BEVESTIGING - FIXATION
BEFESTIGUNG - FIXATION

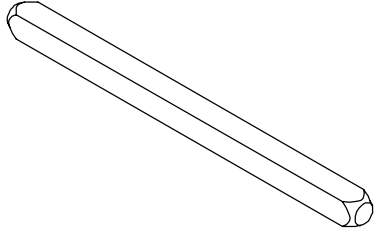
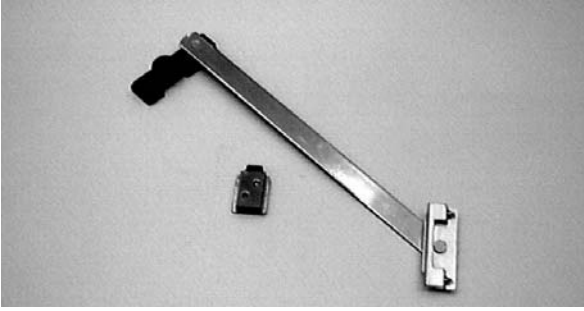
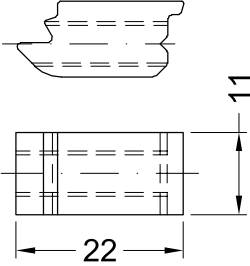

		Verp. per Emb. par Pack pr.	Einheid Unité Einheit Unit	Toepassing Application Anwendung Application	Kleur Couleur Farbe Color												
	ACMX309 -Stift 130X8X8mm -Goupille 130X8X8mm -Weschelstift 130X8X8mm -Change rod 130X8X8mm	1	Stuk Pièce Stück Pièce	ACFA120 ST023	<table border="1"> <tr><td>BR</td><td></td></tr> <tr><td>AN</td><td></td></tr> <tr><td>KL</td><td></td></tr> <tr><td>GS</td><td></td></tr> <tr><td>Z</td><td></td></tr> <tr><td>W</td><td></td></tr> </table>	BR		AN		KL		GS		Z		W	
BR																	
AN																	
KL																	
GS																	
Z																	
W																	
	ACMX587 -Regelbare openingsbegrenzer -Compas limiteur d'ouverture réglable -Verstellbare Schere für Öffnungsbegrenzung -Adjustable limiting opening stay arm	1	Stuk Pièce Stück Pièce	ST010 ST020 ST030 ST130	<table border="1"> <tr><td>BR</td><td></td></tr> <tr><td>AN</td><td></td></tr> <tr><td>KL</td><td></td></tr> <tr><td>GS</td><td></td></tr> <tr><td>Z</td><td></td></tr> <tr><td>W</td><td></td></tr> </table>	BR		AN		KL		GS		Z		W	
BR																	
AN																	
KL																	
GS																	
Z																	
W																	
	ACMX853 -Schroefblokje 11mm -Clavet 11mm -Schraubeblock 11mm -Cleat tensioning block 11mm	48	Stuk Pièce Stück Pièce		<table border="1"> <tr><td>BR</td><td></td></tr> <tr><td>AN</td><td></td></tr> <tr><td>KL</td><td></td></tr> <tr><td>GS</td><td></td></tr> <tr><td>Z</td><td></td></tr> <tr><td>W</td><td></td></tr> </table>	BR		AN		KL		GS		Z		W	
BR																	
AN																	
KL																	
GS																	
Z																	
W																	
 X 10	ACMX860 -DIN965 M5 X 75 -DIN965 M5 X 75 -DIN965 M5 X 75 -DIN965 M5 X 75	100	Stuk Pièce Stück Pièce		<table border="1"> <tr><td>BR</td><td></td></tr> <tr><td>AN</td><td></td></tr> <tr><td>KL</td><td></td></tr> <tr><td>GS</td><td></td></tr> <tr><td>Z</td><td></td></tr> <tr><td>W</td><td></td></tr> </table>	BR		AN		KL		GS		Z		W	
BR																	
AN																	
KL																	
GS																	
Z																	
W																	
 X 10	ACMX861 -DIN965 M5 X 80 -DIN965 M5 X 80 -DIN965 M5 X 80 -DIN965 M5 X 80	100	Stuk Pièce Stück Pièce	ACFA120 ST023	<table border="1"> <tr><td>BR</td><td></td></tr> <tr><td>AN</td><td></td></tr> <tr><td>KL</td><td></td></tr> <tr><td>GS</td><td></td></tr> <tr><td>Z</td><td></td></tr> <tr><td>W</td><td></td></tr> </table>	BR		AN		KL		GS		Z		W	
BR																	
AN																	
KL																	
GS																	
Z																	
W																	

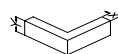

		Verp. per Emb. par Pack pr. Pack pr.	Eenheid Unité Einheit Unit	Toepassing Application Anwendung Application	Kleur Couleur Farbe Color												
	ACMX01601 -Halve cylinder 30 -Demi cylindre 30 -Profil-Halbzyylinder 30 -Profil halfcylinder 30	1	Stuk Pièce Stück Pièce	ST023	<table border="1"> <tr><td>BR</td><td></td></tr> <tr><td>AN</td><td></td></tr> <tr><td>KL</td><td></td></tr> <tr><td>GS</td><td></td></tr> <tr><td>Z</td><td></td></tr> <tr><td>W</td><td></td></tr> </table>	BR		AN		KL		GS		Z		W	
BR																	
AN																	
KL																	
GS																	
Z																	
W																	
	ACMX01611 -Cilinder 30-40 -Cylindre 30-40 -Zylinder 30-40 -Cylinder 30-40	1	Stuk Pièce Stück Pièce	ST224 ST225	<table border="1"> <tr><td>BR</td><td></td></tr> <tr><td>AN</td><td></td></tr> <tr><td>KL</td><td></td></tr> <tr><td>GS</td><td></td></tr> <tr><td>Z</td><td></td></tr> <tr><td>W</td><td></td></tr> </table>	BR		AN		KL		GS		Z		W	
BR																	
AN																	
KL																	
GS																	
Z																	
W																	
	ACMX01613 -Cilinder 30-55 -Cylindre 30-55 -Zylinder 30-55 -Cylinder 30-55	1	Stuk Pièce Stück Pièce	ST023	<table border="1"> <tr><td>BR</td><td></td></tr> <tr><td>AN</td><td></td></tr> <tr><td>KL</td><td></td></tr> <tr><td>GS</td><td></td></tr> <tr><td>Z</td><td></td></tr> <tr><td>W</td><td></td></tr> </table>	BR		AN		KL		GS		Z		W	
BR																	
AN																	
KL																	
GS																	
Z																	
W																	
	ACMX09700 -Alu polish -Alu polish -Alu polish -Alu polish 750ml	1	Stuk Pièce Stück Pièce		<table border="1"> <tr><td>BR</td><td></td></tr> <tr><td>AN</td><td></td></tr> <tr><td>KL</td><td></td></tr> <tr><td>GS</td><td></td></tr> <tr><td>Z</td><td></td></tr> <tr><td>W</td><td></td></tr> </table>	BR		AN		KL		GS		Z		W	
BR																	
AN																	
KL																	
GS																	
Z																	
W																	
	ACMX09761 -Maxi gloss -Maxi gloss -Maxi gloss -Maxi gloss 500ml	1	Stuk Pièce Stück Pièce		<table border="1"> <tr><td>BR</td><td></td></tr> <tr><td>AN</td><td></td></tr> <tr><td>KL</td><td></td></tr> <tr><td>GS</td><td></td></tr> <tr><td>Z</td><td></td></tr> <tr><td>W</td><td></td></tr> </table>	BR		AN		KL		GS		Z		W	
BR																	
AN																	
KL																	
GS																	
Z																	
W																	





BR = BRUT - BRUT - ROH - BRUT
AN (X) = ANODISATIE - ANODISE - ELOXIERT - ANODISED
AN (■) = GELAKT - LAQUE - LACKIERT - LACQUERED -- RAL9006M
KL = STANDAARDKLEUREN - COULEUR STANDARD - BASIS FARBEN - BASIC COLORS
GS = GEMOFFELD SPECIAAL - LAQUE SPECIAL - SPECIALFARBE - SPECIAL COLOR
Z = ZWART - NOIR - SCHWARZ - BLACK
W = WIT - BLANC - WEISS - WHITE

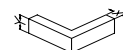

GEREEDSCHAP - OUTILLAGE
WERKZEUG - TOOL

BEVESTIGING - FIXATION
BEFESTIGUNG - FIXATION

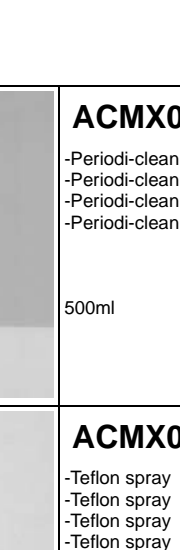

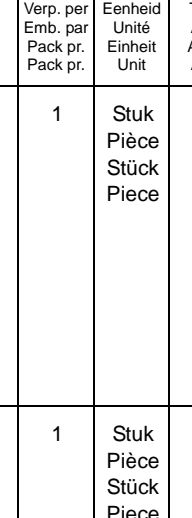
	Verp. per Emb. par Pack pr.	Einheid Unit	Toepassing Application	Kleur Couleur												
 <p>ACMX09762</p> <ul style="list-style-type: none"> -Periodi-clean -Periodi-clean -Periodi-clean -Periodi-clean <p>500ml</p>	1	Stuk Pièce Stück Pièce		<table border="1"> <tr><td>BR</td><td></td></tr> <tr><td>AN</td><td></td></tr> <tr><td>KL</td><td></td></tr> <tr><td>GS</td><td></td></tr> <tr><td>Z</td><td></td></tr> <tr><td>W</td><td></td></tr> </table>	BR		AN		KL		GS		Z		W	
BR																
AN																
KL																
GS																
Z																
W																
 <p>ACMX09763</p> <ul style="list-style-type: none"> -Teflon spray -Teflon spray -Teflon spray -Teflon spray <p>400ml</p>	1	Stuk Pièce Stück Pièce		<table border="1"> <tr><td>BR</td><td></td></tr> <tr><td>AN</td><td></td></tr> <tr><td>KL</td><td></td></tr> <tr><td>GS</td><td></td></tr> <tr><td>Z</td><td></td></tr> <tr><td>W</td><td></td></tr> </table>	BR		AN		KL		GS		Z		W	
BR																
AN																
KL																
GS																
Z																
W																
 <p>ACMX09764</p> <ul style="list-style-type: none"> -Maxi cleaner -Maxi cleaner -Maxi cleaner -Maxi cleaner <p>500ml</p>	1	Stuk Pièce Stück Pièce		<table border="1"> <tr><td>BR</td><td></td></tr> <tr><td>AN</td><td></td></tr> <tr><td>KL</td><td></td></tr> <tr><td>GS</td><td></td></tr> <tr><td>Z</td><td></td></tr> <tr><td>W</td><td></td></tr> </table>	BR		AN		KL		GS		Z		W	
BR																
AN																
KL																
GS																
Z																
W																
 <p>ACMX09765</p> <ul style="list-style-type: none"> -Glue cleaner -Glue cleaner -Glue cleaner -Glue cleaner <p>500ml</p>	1	Stuk Pièce Stück Pièce		<table border="1"> <tr><td>BR</td><td></td></tr> <tr><td>AN</td><td></td></tr> <tr><td>KL</td><td></td></tr> <tr><td>GS</td><td></td></tr> <tr><td>Z</td><td></td></tr> <tr><td>W</td><td></td></tr> </table>	BR		AN		KL		GS		Z		W	
BR																
AN																
KL																
GS																
Z																
W																
 <p>ACMX09766</p> <ul style="list-style-type: none"> -Surface activator -Surface activator -Surface activator -Surface activator <p>1l</p>	1	Stuk Pièce Stück Pièce		<table border="1"> <tr><td>BR</td><td></td></tr> <tr><td>AN</td><td></td></tr> <tr><td>KL</td><td></td></tr> <tr><td>GS</td><td></td></tr> <tr><td>Z</td><td></td></tr> <tr><td>W</td><td></td></tr> </table>	BR		AN		KL		GS		Z		W	
BR																
AN																
KL																
GS																
Z																
W																

BR = BRUT - BRUT - ROH - BRUT
 AN (X) = ANODISATIE - ANODISE - ELOXIERT - ANODISED
 AN (■) = GELAKT - LAQUE - LACKIERT - LACQUERED -- RAL9006M
 KL = STANDAARDKLEUREN - COULEUR STANDARD - BASIS FARBEN - BASIC COLORS
 GS = GEMOFFELD SPECIAAL - LAQUE SPECIAL - SPECIALFARBE - SPECIAL COLOR
 Z = ZWART - NOIR - SCHWARZ - BLACK
 W = WIT - BLANC - WEISS - WHITE



GEREEDSCHAP - OUTILLAGE
 WERKZEUG - TOOL



BEVESTIGING - FIXATION
 BEFESTIGUNG - FIXATION

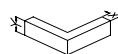

		Verp. per Emb. par Pack pr. Pack pr.	Eenheid Unité Einheit Unit	Toepassing Application Anwendung Application	Kleur Couleur Farbe Color												
	ACMX09767 -Anti-stone opgepast voor natuursteen en metselwerk attention pour pierre de taille et maçonnerie achtung für Naturstein und Mauerwerk attention for natural stone and bricklaying 500ml	1	Stuk Pièce Stück Pièce		<table border="1"> <tr><td>BR</td><td></td></tr> <tr><td>AN</td><td></td></tr> <tr><td>KL</td><td></td></tr> <tr><td>GS</td><td></td></tr> <tr><td>Z</td><td></td></tr> <tr><td>W</td><td></td></tr> </table>	BR		AN		KL		GS		Z		W	
BR																	
AN																	
KL																	
GS																	
Z																	
W																	
	ACMX09770 -Rol andywrap 100mm -Rouleau andywrap 100mm -Rolle andywrap 100mm -Roll andywrap 100mm	150	m		<table border="1"> <tr><td>BR</td><td></td></tr> <tr><td>AN</td><td></td></tr> <tr><td>KL</td><td></td></tr> <tr><td>GS</td><td></td></tr> <tr><td>Z</td><td></td></tr> <tr><td>W</td><td></td></tr> </table>	BR		AN		KL		GS		Z		W	
BR																	
AN																	
KL																	
GS																	
Z																	
W																	
	ACMX09775 -Houder andywrap -Manche andywrap -Halter andywrap -Grip andywrap	1	Stuk Pièce Stück Pièce		<table border="1"> <tr><td>BR</td><td></td></tr> <tr><td>AN</td><td></td></tr> <tr><td>KL</td><td></td></tr> <tr><td>GS</td><td></td></tr> <tr><td>Z</td><td></td></tr> <tr><td>W</td><td></td></tr> </table>	BR		AN		KL		GS		Z		W	
BR																	
AN																	
KL																	
GS																	
Z																	
W																	
	ACMX09801 -Beschermtape 50mm (500m) -Tape de protection 50mm (500m) -Schutz Klebeband 50mm (500m) -Protective tape 50mm (500m)	1	Stuk Pièce Stück Pièce		<table border="1"> <tr><td>BR</td><td></td></tr> <tr><td>AN</td><td></td></tr> <tr><td>KL</td><td></td></tr> <tr><td>GS</td><td></td></tr> <tr><td>Z</td><td></td></tr> <tr><td>W</td><td></td></tr> </table>	BR		AN		KL		GS		Z		W	
BR																	
AN																	
KL																	
GS																	
Z																	
W																	
	ACMX09802 -Beschermtape 70mm (500m) -Tape de protection 70mm (500m) -Schutz Klebeband 70mm (500m) -Protective tape 70mm (500m)	1	Stuk Pièce Stück Pièce		<table border="1"> <tr><td>BR</td><td></td></tr> <tr><td>AN</td><td></td></tr> <tr><td>KL</td><td></td></tr> <tr><td>GS</td><td></td></tr> <tr><td>Z</td><td></td></tr> <tr><td>W</td><td></td></tr> </table>	BR		AN		KL		GS		Z		W	
BR																	
AN																	
KL																	
GS																	
Z																	
W																	

BR = BRUT - BRUT - ROH - BRUT
AN (X) = ANODISATIE - ANODISE - ELOXIERT - ANODISED
AN (■) = GELAKT - LAQUE - LACKIERT - LACQUERED -- RAL9006M
KL = STANDAARDKLEUREN - COULEUR STANDARD - BASIS FARBEN - BASIC COLORS
GS = GEMOFFELD SPECIAAL - LAQUE SPECIAL - SPECIALFARBE - SPECIAL COLOR
Z = ZWART - NOIR - SCHWARZ - BLACK
W = WIT - BLANC - WEISS - WHITE





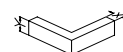

GEREEDSCHAP - OUTILLAGE
WERKZEUG - TOOL

BEVESTIGING - FIXATION
BEFESTIGUNG - FIXATION

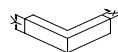

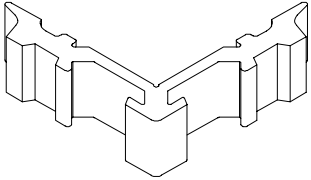
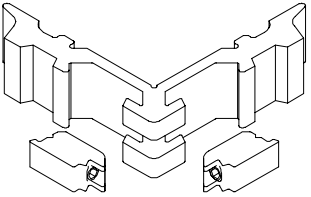

		Verp. per Emb. par Pack pr.	Einheid Unité Einheit Unit	Toepassing Application Anwendung Application	Kleur Couleur Farbe Color												
	<p>ACMX09803</p> <ul style="list-style-type: none"> -Beschermtape 100mm (500m) -Tape de protection 100mm (500m) -Schutz Klebeband 100mm (500m) -Protective tape 100mm (500m) 	1	Stuk Pièce Stück Piece		<table border="1"> <tr><td>BR</td><td></td></tr> <tr><td>AN</td><td></td></tr> <tr><td>KL</td><td></td></tr> <tr><td>GS</td><td></td></tr> <tr><td>Z</td><td></td></tr> <tr><td>W</td><td></td></tr> </table>	BR		AN		KL		GS		Z		W	
BR																	
AN																	
KL																	
GS																	
Z																	
W																	
	<p>ACMX09804</p> <ul style="list-style-type: none"> -Beschermtape 35mm (500m) -Tape de protection 35mm (500m) -Schutz Klebeband 35mm (500m) -Protective tape 35mm (500m) 	1	Stuk Pièce Stück Piece		<table border="1"> <tr><td>BR</td><td></td></tr> <tr><td>AN</td><td></td></tr> <tr><td>KL</td><td></td></tr> <tr><td>GS</td><td></td></tr> <tr><td>Z</td><td></td></tr> <tr><td>W</td><td></td></tr> </table>	BR		AN		KL		GS		Z		W	
BR																	
AN																	
KL																	
GS																	
Z																	
W																	
	<p>ACMX09830</p> <ul style="list-style-type: none"> -Kleefstof voor EPDM-rubbers -Colle pour EPDM-caoutchouc -Dichtmasse + Klebstoff EPDM Gummi -Gum for EPDM rubber 	1	Stuk Pièce Stück Piece		<table border="1"> <tr><td>BR</td><td></td></tr> <tr><td>AN</td><td></td></tr> <tr><td>KL</td><td></td></tr> <tr><td>GS</td><td></td></tr> <tr><td>Z</td><td>X</td></tr> <tr><td>W</td><td></td></tr> </table>	BR		AN		KL		GS		Z	X	W	
BR																	
AN																	
KL																	
GS																	
Z	X																
W																	
	<p>ACSIL04</p> <ul style="list-style-type: none"> -Afdichtingslijmkit voor versteknaden -Joint d'étanchéité pour onglets -Leim für Abdichtung -Sealing glue 	1	Stuk Pièce Stück Piece		<table border="1"> <tr><td>BR</td><td></td></tr> <tr><td>AN</td><td></td></tr> <tr><td>KL</td><td></td></tr> <tr><td>GS</td><td></td></tr> <tr><td>Z</td><td>X</td></tr> <tr><td>W</td><td>X</td></tr> </table>	BR		AN		KL		GS		Z	X	W	X
BR																	
AN																	
KL																	
GS																	
Z	X																
W	X																
	<p>ACSIL08</p> <ul style="list-style-type: none"> -Siliconenpomp -Pistolet doseur pour les tubes silicones -Handkartuschenpistole für die Verarbeitung von Silikone und Leime -Silicon gun 	1	Stuk Pièce Stück Piece		<table border="1"> <tr><td>BR</td><td></td></tr> <tr><td>AN</td><td></td></tr> <tr><td>KL</td><td></td></tr> <tr><td>GS</td><td></td></tr> <tr><td>Z</td><td></td></tr> <tr><td>W</td><td></td></tr> </table>	BR		AN		KL		GS		Z		W	
BR																	
AN																	
KL																	
GS																	
Z																	
W																	





		Verp. per Emb. par Pack pr. Pack pr.	Eenheid Unité Einheit Unit	Toepassing Application Anwendung Application	Kleur Couleur Farbe Color												
	ACSIL013 -Lijm voor verstekhoek -Colle pour onglet -Kleber für Gehrung -Glue for mitre	1	Stuk Pièce Stück Pièce		<table border="1"> <tr><td>BR</td><td></td></tr> <tr><td>AN</td><td></td></tr> <tr><td>KL</td><td></td></tr> <tr><td>GS</td><td></td></tr> <tr><td>Z</td><td></td></tr> <tr><td>W</td><td></td></tr> </table>	BR		AN		KL		GS		Z		W	
BR																	
AN																	
KL																	
GS																	
Z																	
W																	
	ACSIL014 -Anticorro-beschermingsproduct -Anticorro-produit de protection -Anticorro-Schutzprodukt -Anticorro-protection product 500ml	1	Stuk Pièce Stück Pièce		<table border="1"> <tr><td>BR</td><td></td></tr> <tr><td>AN</td><td></td></tr> <tr><td>KL</td><td></td></tr> <tr><td>GS</td><td></td></tr> <tr><td>Z</td><td></td></tr> <tr><td>W</td><td></td></tr> </table>	BR		AN		KL		GS		Z		W	
BR																	
AN																	
KL																	
GS																	
Z																	
W																	
 X=12mm Y=18mm	ACSL012A -Pershoek voor binnenste kamer -Clame à presser pour chambre intérieure -Eckverbinder Stanzbar für innere kammer -Clamping corner for inside chamber	1 24	Stuk Pièce Stück Pièce	TL219	<table border="1"> <tr><td>BR</td><td></td></tr> <tr><td>AN</td><td></td></tr> <tr><td>KL</td><td></td></tr> <tr><td>GS</td><td></td></tr> <tr><td>Z</td><td></td></tr> <tr><td>W</td><td></td></tr> </table>	BR		AN		KL		GS		Z		W	
BR																	
AN																	
KL																	
GS																	
Z																	
W																	
 X=12mm Y=18mm	ACSL013A -Schroefhoek voor binnenste kamer -Clame à visser pour chambre intérieure -Eckverbinder Schraubbar für innere kammer -Square coupling joint for inside chamber  ACVG65	1 24	Stuk Pièce Stück Pièce	TL219	<table border="1"> <tr><td>BR</td><td></td></tr> <tr><td>AN</td><td></td></tr> <tr><td>KL</td><td></td></tr> <tr><td>GS</td><td></td></tr> <tr><td>Z</td><td></td></tr> <tr><td>W</td><td></td></tr> </table>	BR		AN		KL		GS		Z		W	
BR																	
AN																	
KL																	
GS																	
Z																	
W																	
	ACTL202 -Inklembare tweedelige deurscharnier -Charnière de porte encastrable 2 lames -Klembar Türband 2 teilig -Doorhinge clampable 2 parts	1	Stuk Pièce Stück Pièce	TL219 ST224 TL218 ST225	<table border="1"> <tr><td>BR</td><td></td></tr> <tr><td>AN</td><td>X</td></tr> <tr><td>KL</td><td>X</td></tr> <tr><td>GS</td><td>X</td></tr> <tr><td>Z</td><td></td></tr> <tr><td>W</td><td></td></tr> </table>	BR		AN	X	KL	X	GS	X	Z		W	
BR																	
AN	X																
KL	X																
GS	X																
Z																	
W																	

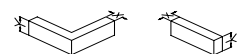

BR = BRUT - BRUT - ROH - BRUT
AN (X) = ANODISATIE - ANODISE - ELOXIERT - ANODISED
AN (■) = GELAKT - LAQUE - LACKIERT - LACQUERED -- RAL9006M
KL = STANDAARDKLEUREN - COULEUR STANDARD - BASIS FARBEN - BASIC COLORS
GS = GEMOFFELD SPECIAAL - LAQUE SPECIAL - SPECIALFARBE - SPECIAL COLOR
Z = ZWART - NOIR - SCHWARZ - BLACK
W = WIT - BLANC - WEISS - WHITE

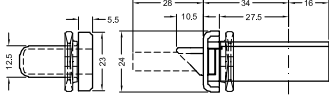
 GEREEDSCHAP - OUTILLAGE
WERKZEUG - TOOL
 BEVESTIGING - FIXATION
BEFESTIGUNG - FIXATION



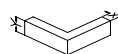

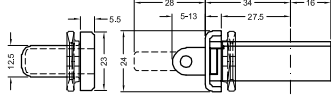
	Verp. per Emb. par Pack pr.	Eenheid Unité Einheit Unit	Toepassing Application Anwendung Application	Kleur Couleur Farbe Color												
	1	Stuk Pièce Stück Piece		<table border="1" style="width: 100%; border-collapse: collapse;"> <tr> <td style="width: 50%; text-align: center;">BR</td> <td style="width: 50%;"></td> </tr> <tr> <td style="text-align: center;">AN</td> <td></td> </tr> <tr> <td style="text-align: center;">KL</td> <td></td> </tr> <tr> <td style="text-align: center;">GS</td> <td></td> </tr> <tr> <td style="text-align: center;">Z</td> <td></td> </tr> <tr> <td style="text-align: center;">W</td> <td></td> </tr> </table>	BR		AN		KL		GS		Z		W	
BR																
AN																
KL																
GS																
Z																
W																
<p>ACTL215</p> <ul style="list-style-type: none"> -3 puntslot -Serrure à 3 points -Schloss für Dreifachsverriegelung -Lock with 3 points  <p> DIN7982 4.2x20</p>																







	Verp. per Emb. par Pack pr. Pack pr.	Eenheid Unité Einheit Unit	Toepassing Application Anwendung Application	Kleur Couleur Farbe Color												
 <p>ACTL216 -3 puntslot -Serrure à 3 points -Schloss für Dreifachsverriegelung -Lock with 3 points</p>  <p> DIN7982 4.2x20</p>	1	Stuk Pièce Stück Pièce		<table border="1"> <tr> <td>BR</td> <td><input type="checkbox"/></td> </tr> <tr> <td>AN</td> <td><input type="checkbox"/></td> </tr> <tr> <td>KL</td> <td><input type="checkbox"/></td> </tr> <tr> <td>GS</td> <td><input type="checkbox"/></td> </tr> <tr> <td>Z</td> <td><input type="checkbox"/></td> </tr> <tr> <td>W</td> <td><input type="checkbox"/></td> </tr> </table>	BR	<input type="checkbox"/>	AN	<input type="checkbox"/>	KL	<input type="checkbox"/>	GS	<input type="checkbox"/>	Z	<input type="checkbox"/>	W	<input type="checkbox"/>
BR	<input type="checkbox"/>															
AN	<input type="checkbox"/>															
KL	<input type="checkbox"/>															
GS	<input type="checkbox"/>															
Z	<input type="checkbox"/>															
W	<input type="checkbox"/>															



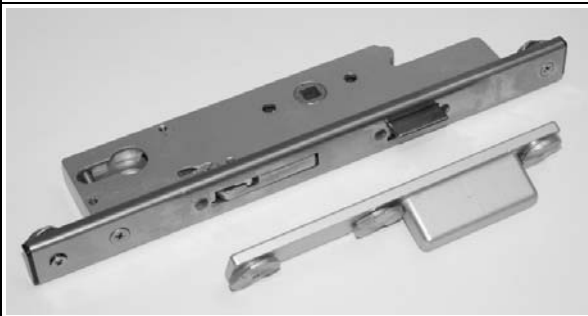
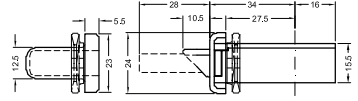

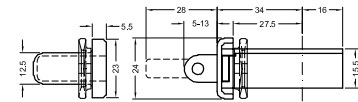
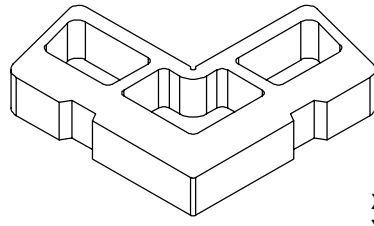
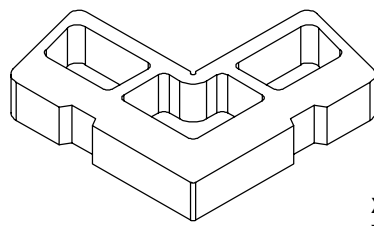
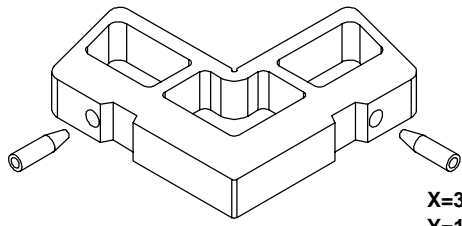
BR = BRUT - BRUT - ROH - BRUT
 AN (X) = ANODISATIE - ANODISE - ELOXIERT - ANODISED
 AN (■) = GELAKT - LAQUE - LACKIERT - LACQUERED -- RAL9006M
 KL = STANDAARDKLEUREN - COULEUR STANDARD - BASIS FARBEN - BASIC COLORS
 GS = GEMOFFELD SPECIAAL - LAQUE SPECIAL - SPECIALFARBE - SPECIAL COLOR
 Z = ZWART - NOIR - SCHWARZ - BLACK
 W = WIT - BLANC - WEISS - WHITE

 GEREEDSCHAP - OUTILLAGE
 WERKZEUG - TOOL
 BEVESTIGING - FIXATION
 BEFESTIGUNG - FIXATION

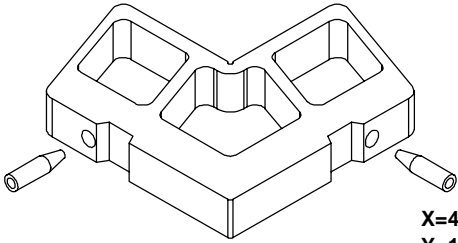

		Verp. per Emb. par Pack pr.	Einheit Unit	Toepassing Application	Kleur Couleur Farbe Color												
	<p>ACTL217</p> <ul style="list-style-type: none"> -Veiligheidsslot met pen -Serrure de sécurité à pêne -Sicherheitsschloss mit Falle -Security lock with pen 	1	Stuk Pièce Stück Piece		<table border="1"> <tr><td>BR</td><td></td></tr> <tr><td>AN</td><td></td></tr> <tr><td>KL</td><td></td></tr> <tr><td>GS</td><td></td></tr> <tr><td>Z</td><td></td></tr> <tr><td>W</td><td></td></tr> </table>	BR		AN		KL		GS		Z		W	
BR																	
AN																	
KL																	
GS																	
Z																	
W																	
	<p>ACTL218</p> <ul style="list-style-type: none"> -1 Puntslot met rol -Serrure 1 point avec rouleau -1 Punkt Schloss mit Rolle -Lock with roll 	1	Stuk Pièce Stück Piece		<table border="1"> <tr><td>BR</td><td></td></tr> <tr><td>AN</td><td></td></tr> <tr><td>KL</td><td></td></tr> <tr><td>GS</td><td></td></tr> <tr><td>Z</td><td></td></tr> <tr><td>W</td><td></td></tr> </table>	BR		AN		KL		GS		Z		W	
BR																	
AN																	
KL																	
GS																	
Z																	
W																	
	<p>ACTL220A</p> <ul style="list-style-type: none"> -Pershoek voor buitenste kamer -Clame à presser pour chambre extérieure -Eckverbinder stanbar für aussere Kammer -Clamping corner for outside chamber <p>X=36mm Y=12mm</p>	1	Stuk Pièce Stück Piece	ST224 ST225	<table border="1"> <tr><td>BR</td><td></td></tr> <tr><td>AN</td><td></td></tr> <tr><td>KL</td><td></td></tr> <tr><td>GS</td><td></td></tr> <tr><td>Z</td><td></td></tr> <tr><td>W</td><td></td></tr> </table>	BR		AN		KL		GS		Z		W	
BR																	
AN																	
KL																	
GS																	
Z																	
W																	
	<p>ACTL220B</p> <ul style="list-style-type: none"> -Pershoek voor binnenste kamer -Clame à presser pour chambre intérieure -Eckverbinder stanbar für innere Kammer -Clamping corner for inside chamber <p>X=45mm Y=12mm</p>	1	Stuk Pièce Stück Piece	ST224 ST225	<table border="1"> <tr><td>BR</td><td></td></tr> <tr><td>AN</td><td></td></tr> <tr><td>KL</td><td></td></tr> <tr><td>GS</td><td></td></tr> <tr><td>Z</td><td></td></tr> <tr><td>W</td><td></td></tr> </table>	BR		AN		KL		GS		Z		W	
BR																	
AN																	
KL																	
GS																	
Z																	
W																	
	<p>ACTL221A</p> <ul style="list-style-type: none"> -Stifhoek buitenste kamer -Equerre à goupiller pour chambre extérieure -Verstiftbare eckwinkel für aussere kammer -Corner bracket with pin for outside chamber <p>X=36mm Y=12mm</p>  ACDV235	1	Stuk Pièce Stück Piece	ST224 ST225	<table border="1"> <tr><td>BR</td><td></td></tr> <tr><td>AN</td><td></td></tr> <tr><td>KL</td><td></td></tr> <tr><td>GS</td><td></td></tr> <tr><td>Z</td><td></td></tr> <tr><td>W</td><td></td></tr> </table>	BR		AN		KL		GS		Z		W	
BR																	
AN																	
KL																	
GS																	
Z																	
W																	

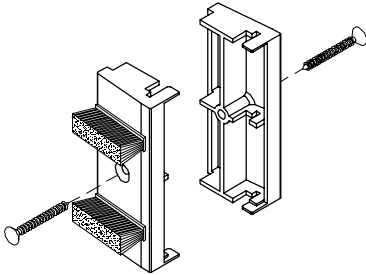

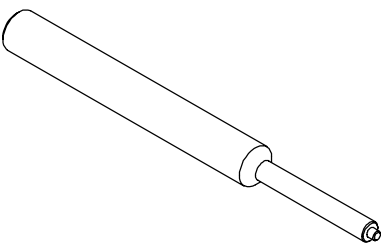
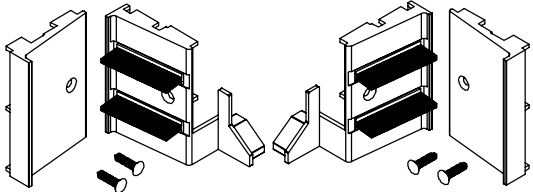
		Verp. per Emb. par Pack pr. Pack pr.	Eenheid Unité Einheit Unit	Toepassing Application Anwendung Application	Kleur Couleur Farbe Color											
 <p>ACTL221B -Stifthoek binnenste kamer -Equerre à goupiller pour chambre intérieure -Verstiftbare eckwinkel für innere kammer -Corner bracket with pin for inside chamber</p> <p>X=45mm Y=12mm</p>  ACDV235	1	Stuk Pièce Stück Piece	ST224 ST225	<table border="1"> <tr><td>BR</td><td></td></tr> <tr><td>AN</td><td></td></tr> <tr><td>KL</td><td></td></tr> <tr><td>GS</td><td></td></tr> <tr><td>Z</td><td></td></tr> <tr><td>W</td><td></td></tr> </table>	BR		AN		KL		GS		Z		W	
BR																
AN																
KL																
GS																
Z																
W																
 <p>ACTL225 -Sluistukjes voor deur -Pièce d'étanchéité pour porte -Tür Abschluss für Tür -Closer section for door</p>	1	Set	ST224 ST225	<table border="1"> <tr><td>BR</td><td></td></tr> <tr><td>AN</td><td></td></tr> <tr><td>KL</td><td></td></tr> <tr><td>GS</td><td></td></tr> <tr><td>Z</td><td>X</td></tr> <tr><td>W</td><td>X</td></tr> </table>	BR		AN		KL		GS		Z	X	W	X
BR																
AN																
KL																
GS																
Z	X															
W	X															
 <p>ACTL232 -Aanslagdichting deuren -Joint pour portes -Flügeldichtung Türen -Gasket for doors</p>	100	m		<table border="1"> <tr><td>BR</td><td></td></tr> <tr><td>AN</td><td></td></tr> <tr><td>KL</td><td></td></tr> <tr><td>GS</td><td></td></tr> <tr><td>Z</td><td></td></tr> <tr><td>W</td><td></td></tr> </table>	BR		AN		KL		GS		Z		W	
BR																
AN																
KL																
GS																
Z																
W																
 <p>ACTL235 -Doorslag voor ST deur -Poinçon pour ST porte -Schlagdorn für ST Tür -Pin punch for ST door</p>	1	Stuk Pièce Stück Piece		<table border="1"> <tr><td>BR</td><td></td></tr> <tr><td>AN</td><td></td></tr> <tr><td>KL</td><td></td></tr> <tr><td>GS</td><td></td></tr> <tr><td>Z</td><td></td></tr> <tr><td>W</td><td></td></tr> </table>	BR		AN		KL		GS		Z		W	
BR																
AN																
KL																
GS																
Z																
W																
 <p>ACTL443 -Sluistukjes voor enkele deur -Pièce d'étanchéité pour porte simple -Türabschluss für 1 Flügel -Closer section for single door</p>	1	Stuk Pièce Stück Piece	ST023	<table border="1"> <tr><td>BR</td><td></td></tr> <tr><td>AN</td><td></td></tr> <tr><td>KL</td><td></td></tr> <tr><td>GS</td><td></td></tr> <tr><td>Z</td><td></td></tr> <tr><td>W</td><td></td></tr> </table>	BR		AN		KL		GS		Z		W	
BR																
AN																
KL																
GS																
Z																
W																

BR = BRUT - BRUT - ROH - BRUT
AN (X) = ANODISATIE - ANODISE - ELOXIERT - ANODISED
AN (■) = GELAKT - LAQUE - LACKIERT - LACQUERED -- RAL9006M
KL = STANDAARDKLEUREN - COULEUR STANDARD - BASIS FARBEN - BASIC COLORS
GS = GEMOFFELD SPECIAAL - LAQUE SPECIAL - SPECIALFARBEN - SPECIAL COLOR
Z = ZWART - NOIR - SCHWARZ - BLACK
W = WIT - BLANC - WEISS - WHITE



GEREEDSCHAP - OUTILLAGE
WERKZEUG - TOOL





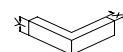

BEVESTIGING - FIXATION
BEFESTIGUNG - FIXATION

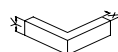

	Verp. per Emb. par Pack pr.	Einheid Unit	Toepassing Application	Kleur Couleur												
 <p>ACUN040 -Verdoken scharnier -Paumelle cache -Verborgen band -Hidden hinge</p>	1	Stuk Pièce Stück Piece	ST010 ST110 ST210	<table border="1"> <tr><td>BR</td><td>X</td></tr> <tr><td>AN</td><td></td></tr> <tr><td>KL</td><td></td></tr> <tr><td>GS</td><td></td></tr> <tr><td>Z</td><td></td></tr> <tr><td>W</td><td></td></tr> </table>	BR	X	AN		KL		GS		Z		W	
BR	X															
AN																
KL																
GS																
Z																
W																
 <p>ACUN042 -Bijkomend sluitpunt -Point de verrouillage supplementair -Mittelverschluss -Adjusting lock plate</p>	1	Stuk Pièce Stück Piece	ACUN040	<table border="1"> <tr><td>BR</td><td>X</td></tr> <tr><td>AN</td><td></td></tr> <tr><td>KL</td><td></td></tr> <tr><td>GS</td><td></td></tr> <tr><td>Z</td><td></td></tr> <tr><td>W</td><td></td></tr> </table>	BR	X	AN		KL		GS		Z		W	
BR	X															
AN																
KL																
GS																
Z																
W																
 <p>ACVG231 -Beglazingsrubber buiten 2mm -Joint de vitrage extérieure 2mm -Glasanlage Dichtung 2mm -Glazing gasket outside 2mm</p>	200	m	ST010 ST020 ST030 ST130	<table border="1"> <tr><td>BR</td><td></td></tr> <tr><td>AN</td><td></td></tr> <tr><td>KL</td><td></td></tr> <tr><td>GS</td><td></td></tr> <tr><td>Z</td><td>X</td></tr> <tr><td>W</td><td></td></tr> </table>	BR		AN		KL		GS		Z	X	W	
BR																
AN																
KL																
GS																
Z	X															
W																
 <p>ACVG231N -Beglazingsrubber buiten 2mm rondlopend -Joint de vitrage extérieure 2mm tournant -Glasanlage Dichtung 2mm -Glazing gasket outside 2mm</p>	200	m	ST010 ST020 ST030 ST130	<table border="1"> <tr><td>BR</td><td></td></tr> <tr><td>AN</td><td></td></tr> <tr><td>KL</td><td></td></tr> <tr><td>GS</td><td></td></tr> <tr><td>Z</td><td>X</td></tr> <tr><td>W</td><td></td></tr> </table>	BR		AN		KL		GS		Z	X	W	
BR																
AN																
KL																
GS																
Z	X															
W																
 <p>ACVG31 -Beglazingsrubber buiten 3mm -Joint de vitrage extérieure 3mm -Glasanlage Dichtung 3mm -Glazing gasket outside 3mm</p>	200	m	ST010 ST020 ST030 ST130	<table border="1"> <tr><td>BR</td><td></td></tr> <tr><td>AN</td><td></td></tr> <tr><td>KL</td><td></td></tr> <tr><td>GS</td><td></td></tr> <tr><td>Z</td><td>X</td></tr> <tr><td>W</td><td></td></tr> </table>	BR		AN		KL		GS		Z	X	W	
BR																
AN																
KL																
GS																
Z	X															
W																



		Verp. per Emb. par Pack pr. Pack pr.	Eenheid Unité Einheit Unit	Toepassing Application Anwendung Application	Kleur Couleur Farbe Color												
	ACVG31N -Beglazingsrubber buiten 3mm rondlopend -Joint de vitrage extérieure 3mm tournant -Glasanlage Dichtung 3mm -Glazing gasket outside 3mm	200	m	ST010 ST020 ST030 ST130	<table border="1"> <tr><td>BR</td><td></td></tr> <tr><td>AN</td><td></td></tr> <tr><td>KL</td><td></td></tr> <tr><td>GS</td><td></td></tr> <tr><td>Z</td><td>X</td></tr> <tr><td>W</td><td></td></tr> </table>	BR		AN		KL		GS		Z	X	W	
BR																	
AN																	
KL																	
GS																	
Z	X																
W																	
	ACVG131 -Beglazingsrubber buiten 4mm -Joint de vitrage extérieure 4mm -Glasanlage Dichtung 4mm -Glazing gasket outside 4mm	100	m	ST010 ST020 ST030 ST130	<table border="1"> <tr><td>BR</td><td></td></tr> <tr><td>AN</td><td></td></tr> <tr><td>KL</td><td></td></tr> <tr><td>GS</td><td></td></tr> <tr><td>Z</td><td>X</td></tr> <tr><td>W</td><td></td></tr> </table>	BR		AN		KL		GS		Z	X	W	
BR																	
AN																	
KL																	
GS																	
Z	X																
W																	
	ACVG131N -Beglazingsrubber buiten 4mm rondlopend -Joint de vitrage extérieure 4mm tournant -Glasanlage Dichtung 4mm -Glazing gasket outside 4mm	100	m	ST010 ST020 ST030 ST130	<table border="1"> <tr><td>BR</td><td></td></tr> <tr><td>AN</td><td></td></tr> <tr><td>KL</td><td></td></tr> <tr><td>GS</td><td></td></tr> <tr><td>Z</td><td>X</td></tr> <tr><td>W</td><td></td></tr> </table>	BR		AN		KL		GS		Z	X	W	
BR																	
AN																	
KL																	
GS																	
Z	X																
W																	
	ACVG32 -Beglazingsrubber 3mm -Joint de vitrage 3mm -Glasdichtung 3mm -Glazing gasket 3mm	100	m	ST062	<table border="1"> <tr><td>BR</td><td></td></tr> <tr><td>AN</td><td></td></tr> <tr><td>KL</td><td></td></tr> <tr><td>GS</td><td></td></tr> <tr><td>Z</td><td>X</td></tr> <tr><td>W</td><td></td></tr> </table>	BR		AN		KL		GS		Z	X	W	
BR																	
AN																	
KL																	
GS																	
Z	X																
W																	
	ACVG32N -Beglazingsrubber 3mm rondlopend -Joint de vitrage 3mm tournant -Glasdichtung 3mm -Glazing gasket 3mm	100	m	ST062	<table border="1"> <tr><td>BR</td><td></td></tr> <tr><td>AN</td><td></td></tr> <tr><td>KL</td><td></td></tr> <tr><td>GS</td><td></td></tr> <tr><td>Z</td><td>X</td></tr> <tr><td>W</td><td></td></tr> </table>	BR		AN		KL		GS		Z	X	W	
BR																	
AN																	
KL																	
GS																	
Z	X																
W																	

BR = BRUT - BRUT - ROH - BRUT
AN (X) = ANODISATIE - ANODISE - ELOXIERT - ANODISED
AN (■) = GELAKT - LAQUE - LACKIERT - LACQUERED -- RAL9006M
KL = STANDAARDKLEUREN - COULEUR STANDARD - BASIS FARBEN - BASIC COLORS
GS = GEMOFFELD SPECIAAL - LAQUE SPECIAL - SPECIALFARBE - SPECIAL COLOR
Z = ZWART - NOIR - SCHWARZ - BLACK
W = WIT - BLANC - WEISS - WHITE







GEREEDSCHAP - OUTILLAGE
WERKZEUG - TOOL

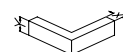

BEVESTIGING - FIXATION
BEFESTIGUNG - FIXATION

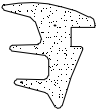

		Verp. per Emb. par Pack pr.	Einheid Unité Unit	Toepassing Application Anwendung Application	Kleur Couleur Farbe Color												
	ACVG33 -Beglazingsrubber 4mm -Joint de vitrage 4mm -Glasdichtung 4mm -Glazing gasket 4mm	100	m	ST062	<table border="1"> <tr><td>BR</td><td></td></tr> <tr><td>AN</td><td></td></tr> <tr><td>KL</td><td></td></tr> <tr><td>GS</td><td></td></tr> <tr><td>Z</td><td>X</td></tr> <tr><td>W</td><td></td></tr> </table>	BR		AN		KL		GS		Z	X	W	
BR																	
AN																	
KL																	
GS																	
Z	X																
W																	
	ACVG33N -Beglazingsrubber 4mm rondlopend -Joint de vitrage 4mm tournant -Glasdichtung 4mm -Glazing gasket 4mm	100	m	ST062	<table border="1"> <tr><td>BR</td><td></td></tr> <tr><td>AN</td><td></td></tr> <tr><td>KL</td><td></td></tr> <tr><td>GS</td><td></td></tr> <tr><td>Z</td><td>X</td></tr> <tr><td>W</td><td></td></tr> </table>	BR		AN		KL		GS		Z	X	W	
BR																	
AN																	
KL																	
GS																	
Z	X																
W																	
	ACVG34 -Beglazingsrubber 5mm -Joint de vitrage 5mm -Glasdichtung 5mm -Glazing gasket 5mm	100	m	ST062	<table border="1"> <tr><td>BR</td><td></td></tr> <tr><td>AN</td><td></td></tr> <tr><td>KL</td><td></td></tr> <tr><td>GS</td><td></td></tr> <tr><td>Z</td><td>X</td></tr> <tr><td>W</td><td></td></tr> </table>	BR		AN		KL		GS		Z	X	W	
BR																	
AN																	
KL																	
GS																	
Z	X																
W																	
	ACVG34N -Beglazingsrubber 5mm rondlopend -Joint de vitrage 5mm tournant -Glasdichtung 5mm -Glazing gasket 5mm	100	m	ST062	<table border="1"> <tr><td>BR</td><td></td></tr> <tr><td>AN</td><td></td></tr> <tr><td>KL</td><td></td></tr> <tr><td>GS</td><td></td></tr> <tr><td>Z</td><td>X</td></tr> <tr><td>W</td><td></td></tr> </table>	BR		AN		KL		GS		Z	X	W	
BR																	
AN																	
KL																	
GS																	
Z	X																
W																	
	ACVG340 -Beglazingsrubber 6mm -Joint de vitrage 6mm -Glasdichtung 6mm -Glazing gasket 6mm	200	m	ST062	<table border="1"> <tr><td>BR</td><td></td></tr> <tr><td>AN</td><td></td></tr> <tr><td>KL</td><td></td></tr> <tr><td>GS</td><td></td></tr> <tr><td>Z</td><td>X</td></tr> <tr><td>W</td><td></td></tr> </table>	BR		AN		KL		GS		Z	X	W	
BR																	
AN																	
KL																	
GS																	
Z	X																
W																	

BR = BRUT - BRUT - ROH - BRUT
 AN (X) = ANODISATIE - ANODISE - ELOXIERT - ANODISED
 AN (■) = GELAKT - LAQUE - LACKIERT - LACQUERED -- RAL9006M
 KL = STANDAARDKLEUREN - COULEUR STANDARD - BASIS FARBEN - BASIC COLORS
 GS = GEMOFFELD SPECIAAL - LAQUE SPECIAL - SPECIALFARBE - SPECIAL COLOR
 Z = ZWART - NOIR - SCHWARZ - BLACK
 W = WIT - BLANC - WEISS - WHITE







GEREEDSCHAP - OUTILLAGE
WERKZEUG - TOOL

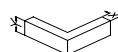

BEVESTIGING - FIXATION
BEFESTIGUNG - FIXATION

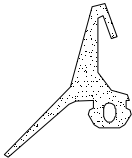

		Verp. per Emb. par Pack pr. Pack pr.	Eenheid Unité Einheit Unit	Toepassing Application Anwendung Application	Kleur Couleur Farbe Color												
	ACVG340N -Beglazingsrubber 6mm rondlopend -Joint de vitrage 6mm tournant -Glasdichtung 6mm -Glazing gasket 6mm	100	m	ST062	<table border="1"> <tr><td>BR</td><td></td></tr> <tr><td>AN</td><td></td></tr> <tr><td>KL</td><td></td></tr> <tr><td>GS</td><td></td></tr> <tr><td>Z</td><td>X</td></tr> <tr><td>W</td><td></td></tr> </table>	BR		AN		KL		GS		Z	X	W	
BR																	
AN																	
KL																	
GS																	
Z	X																
W																	
	ACVG45 -Afdekkapje waterafvoer -Capuchon écoulement d'eau -Abdeckkappe entwässerung -Drain hole cover	1	Stuk Pièce Stück Piece	ST210 ST230	<table border="1"> <tr><td>BR</td><td></td></tr> <tr><td>AN</td><td></td></tr> <tr><td>KL</td><td>X</td></tr> <tr><td>GS</td><td></td></tr> <tr><td>Z</td><td>X</td></tr> <tr><td>W</td><td>X</td></tr> </table>	BR		AN		KL	X	GS		Z	X	W	X
BR																	
AN																	
KL	X																
GS																	
Z	X																
W	X																
	ACVL030 -Middendichting -Joint centrale -Mitteldichtung -Central gasket	100	m	ST010 ST030 ST040 ST130	<table border="1"> <tr><td>BR</td><td></td></tr> <tr><td>AN</td><td></td></tr> <tr><td>KL</td><td></td></tr> <tr><td>GS</td><td></td></tr> <tr><td>Z</td><td>X</td></tr> <tr><td>W</td><td></td></tr> </table>	BR		AN		KL		GS		Z	X	W	
BR																	
AN																	
KL																	
GS																	
Z	X																
W																	
	ACVL031 -Aanslagdichting ramen -Joint pour fenêtres -Flügeldichtung Rahmen -Gasket for windows	100	m	ST020	<table border="1"> <tr><td>BR</td><td></td></tr> <tr><td>AN</td><td></td></tr> <tr><td>KL</td><td></td></tr> <tr><td>GS</td><td></td></tr> <tr><td>Z</td><td>X</td></tr> <tr><td>W</td><td></td></tr> </table>	BR		AN		KL		GS		Z	X	W	
BR																	
AN																	
KL																	
GS																	
Z	X																
W																	
	ACVL031N -Aanslagdichting ramen ronddraaiend -Joint pour fenêtres tournant -Flügeldichtung Rahmen herumdrehend -Gasket for windows rotated	100	m	ST020	<table border="1"> <tr><td>BR</td><td></td></tr> <tr><td>AN</td><td></td></tr> <tr><td>KL</td><td></td></tr> <tr><td>GS</td><td></td></tr> <tr><td>Z</td><td>X</td></tr> <tr><td>W</td><td></td></tr> </table>	BR		AN		KL		GS		Z	X	W	
BR																	
AN																	
KL																	
GS																	
Z	X																
W																	

BR = BRUT - BRUT - ROH - BRUT
 AN (X) = ANODISATIE - ANODISE - ELOXIERT - ANODISED
 AN (■) = GELAKT - LAQUE - LACKIERT - LACQUERED -- RAL9006M
 KL = STANDAARDKLEUREN - COULEUR STANDARD - BASIS FARBEN - BASIC COLORS
 GS = GEMOFFELD SPECIAAL - LAQUE SPECIAL - SPECIALFARBE - SPECIAL COLOR
 Z = ZWART - NOIR - SCHWARZ - BLACK
 W = WIT - BLANC - WEISS - WHITE







GEREEDSCHAP - OUTILLAGE
 WERKZEUG - TOOL

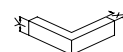

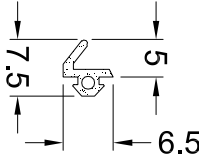
BEVESTIGING - FIXATION
 BEFESTIGUNG - FIXATION



	Verp. per Emb. par Pack pr.	Eenheid Unit	Toepassing Application	Kleur Couleur Farbe Color												
 <p>ACVL032 -Aanslagdichting -Joint pour ouvrant -Flügelichtung -Gasket</p>	100	m	ST061	<table border="1"> <tr><td>BR</td><td></td></tr> <tr><td>AN</td><td></td></tr> <tr><td>KL</td><td></td></tr> <tr><td>GS</td><td></td></tr> <tr><td>Z</td><td>X</td></tr> <tr><td>W</td><td></td></tr> </table>	BR		AN		KL		GS		Z	X	W	
BR																
AN																
KL																
GS																
Z	X															
W																
 <p>ACVL032N -Aanslagdichting rondlopend -Joint pour ouvrant tournant -Flügelichtung herumdrehend -Gasket rotated</p>	100	m	ST061	<table border="1"> <tr><td>BR</td><td></td></tr> <tr><td>AN</td><td></td></tr> <tr><td>KL</td><td></td></tr> <tr><td>GS</td><td></td></tr> <tr><td>Z</td><td>X</td></tr> <tr><td>W</td><td></td></tr> </table>	BR		AN		KL		GS		Z	X	W	
BR																
AN																
KL																
GS																
Z	X															
W																
 <p>ACVL057 -Glassteun -Support calle de vitrage -Klotz-auflege -Glazing support</p>	1	Stuk Pièce Stück Piece	ST023	<table border="1"> <tr><td>BR</td><td></td></tr> <tr><td>AN</td><td></td></tr> <tr><td>KL</td><td></td></tr> <tr><td>GS</td><td></td></tr> <tr><td>Z</td><td></td></tr> <tr><td>W</td><td></td></tr> </table>	BR		AN		KL		GS		Z		W	
BR																
AN																
KL																
GS																
Z																
W																
 <p>ACVL117 -Cilinder 30-50 -Cylindre 30-50 -Zylinder 30-50 -Cylinder 30-50</p>	1	Stuk Pièce Stück Piece	ST023 ACMX208	<table border="1"> <tr><td>BR</td><td></td></tr> <tr><td>AN</td><td></td></tr> <tr><td>KL</td><td></td></tr> <tr><td>GS</td><td></td></tr> <tr><td>Z</td><td></td></tr> <tr><td>W</td><td></td></tr> </table>	BR		AN		KL		GS		Z		W	
BR																
AN																
KL																
GS																
Z																
W																
 <p>ACVL432 -Deurgrendel voor driepuntslot -Verrou porte pour serrure à 3 points -Türkantriegel für Treipunktschloss -Extended bolt for lock with 3 points</p>	1	Stuk Pièce Stück Piece		<table border="1"> <tr><td>BR</td><td></td></tr> <tr><td>AN</td><td></td></tr> <tr><td>KL</td><td></td></tr> <tr><td>GS</td><td></td></tr> <tr><td>Z</td><td></td></tr> <tr><td>W</td><td></td></tr> </table>	BR		AN		KL		GS		Z		W	
BR																
AN																
KL																
GS																
Z																
W																

BR = BRUT - BRUT - ROH - BRUT
 AN (X) = ANODISATIE - ANODISE - ELOXIERT - ANODISED
 AN (■) = GELAKT - LAQUE - LACKIERT - LACQUERED -- RAL9006M
 KL = STANDAARDKLEUREN - COULEUR STANDARD - BASIS FARBEN - BASIC COLORS
 GS = GEMOFFELD SPECIAAL - LAQUE SPECIAL - SPECIALFARBE - SPECIAL COLOR
 Z = ZWART - NOIR - SCHWARZ - BLACK
 W = WIT - BLANC - WEISS - WHITE







GEREEDSCHAP - OUTILLAGE
WERKZEUG - TOOL



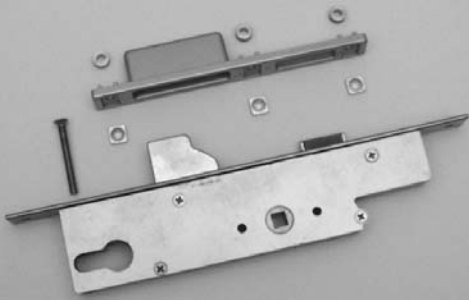
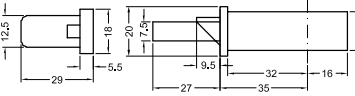

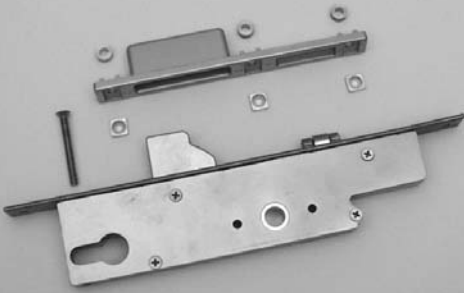
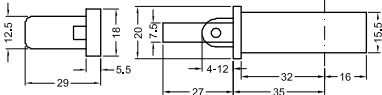
BEVESTIGING - FIXATION
BEFESTIGUNG - FIXATION





		Verp. per Emb. par Pack pr. Pack pr.	Eenheid Unité Einheit Unit	Toepassing Application Anwendung Application	Kleur Couleur Farbe Color												
	ACVL434 -Sluitstuk voor ACVL432 -Gache pour ACVL432 -Schliessplatte für ACVL432 -Keeper for ACVL432	1	Stuk Pièce Stück Pièce	ACVL432	<table border="1"> <tr><td>BR</td><td></td></tr> <tr><td>AN</td><td></td></tr> <tr><td>KL</td><td></td></tr> <tr><td>GS</td><td></td></tr> <tr><td>Z</td><td></td></tr> <tr><td>W</td><td></td></tr> </table>	BR		AN		KL		GS		Z		W	
BR																	
AN																	
KL																	
GS																	
Z																	
W																	
	ACVL705 -Veiligheidsslot met pen -Serrure de sécurité à pêne -Sicherheitsschloss mit Falle -Security lock with pen   DIN7982 4.2x20	1	Stuk Pièce Stück Pièce	ST023	<table border="1"> <tr><td>BR</td><td></td></tr> <tr><td>AN</td><td></td></tr> <tr><td>KL</td><td></td></tr> <tr><td>GS</td><td></td></tr> <tr><td>Z</td><td></td></tr> <tr><td>W</td><td></td></tr> </table>	BR		AN		KL		GS		Z		W	
BR																	
AN																	
KL																	
GS																	
Z																	
W																	
	ACVL706 -Veiligheidsslot met rol -Serrure de sécurité avec rouleau -Sicherheitsschloss mit Rolle -Security lock with rol   DIN7982 4.2x20	1	Stuk Pièce Stück Pièce	ST023	<table border="1"> <tr><td>BR</td><td></td></tr> <tr><td>AN</td><td></td></tr> <tr><td>KL</td><td></td></tr> <tr><td>GS</td><td></td></tr> <tr><td>Z</td><td></td></tr> <tr><td>W</td><td></td></tr> </table>	BR		AN		KL		GS		Z		W	
BR																	
AN																	
KL																	
GS																	
Z																	
W																	

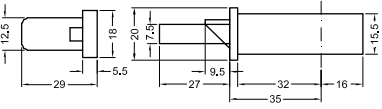

BR = BRUT - BRUT - ROH - BRUT
 AN (X) = ANODISATIE - ANODISE - ELOXIERT - ANODISED
 AN (■) = GELAKT - LAQUE - LACKIERT - LACQUERED -- RAL9006M
 KL = STANDAARDKLEUREN - COULEUR STANDARD - BASIS FARBEN - BASIC COLORS
 GS = GEMOFFELD SPECIAAL - LAQUE SPECIAL - SPECIALFARBE - SPECIAL COLOR
 Z = ZWART - NOIR - SCHWARZ - BLACK
 W = WIT - BLANC - WEISS - WHITE

 GEREEDSCHAP - OUTILLAGE
 WERKZEUG - TOOL
 BEVESTIGING - FIXATION
 BEFESTIGUNG - FIXATION



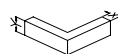

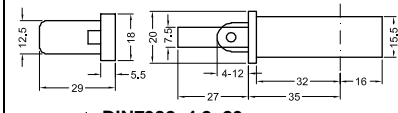
	Verp. per Emb. par Pack pr.	Eenheid Unit	Toepassing Application	Kleur Colour												
	1	Stuk Pièce Stück Piece	ST023	<table border="1"> <thead> <tr> <th>BR</th> <th>X</th> </tr> </thead> <tbody> <tr> <td>AN</td> <td></td> </tr> <tr> <td>KL</td> <td></td> </tr> <tr> <td>GS</td> <td></td> </tr> <tr> <td>Z</td> <td></td> </tr> <tr> <td>W</td> <td></td> </tr> </tbody> </table>	BR	X	AN		KL		GS		Z		W	
BR	X															
AN																
KL																
GS																
Z																
W																
<p>ACVL707</p> <ul style="list-style-type: none"> -Driepuntsslot -Serrure à 3 points -Schloss für Dreifachverriegelung -Lock with 3 points  <p> DIN7982 4.2x20</p>																



	Verp. per Emb. par Pack pr. Pack pr.	Eenheid Unité Einheit Unit	Toepassing Application Anwendung Application	Kleur Couleur Farbe Color												
 <p>ACVL708 -Driepuntsslot met rol -Serrure à 3 points avec rouleau -Schloss für Dreifachverriegelung mit Rolle -Lock with 3 points and rol</p>  <p> DIN7982 4.2x20</p>	1	Stuk Pièce Stück Piece	ST023	<table border="1"> <tr><td>BR</td><td></td></tr> <tr><td>AN</td><td></td></tr> <tr><td>KL</td><td></td></tr> <tr><td>GS</td><td></td></tr> <tr><td>Z</td><td></td></tr> <tr><td>W</td><td></td></tr> </table>	BR		AN		KL		GS		Z		W	
BR																
AN																
KL																
GS																
Z																
W																

BR = BRUT - BRUT - ROH - BRUT
 AN (X) = ANODISATIE - ANODISE - ELOXIERT - ANODISED
 AN (■) = GELAKT - LAQUE - LACKIERT - LACQUERED -- RAL9006M
 KL = STANDAARDKLEUREN - COULEUR STANDARD - BASIS FARBEN - BASIC COLORS
 GS = GEMOFFELD SPECIAAL - LAQUE SPECIAL - SPECIALFARBE - SPECIAL COLOR
 Z = ZWART - NOIR - SCHWARZ - BLACK
 W = WIT - BLANC - WEISS - WHITE

 GEREEDSCHAP - OUTILLAGE
 WERKZEUG - TOOL
 BEVESTIGING - FIXATION
 BEFESTIGUNG - FIXATION



ACINDA10 / ACINDA16

	1 (kg)	2 (mm)	3 (mm)	4 (mm)	Opening Angle	A (mm)	B (mm)	C (mm)	D (mm)	E (mm)
ACINDA10	16	275	500	1200	80°	32,25	152,75	-	179,9	223,2
ACINDA16	21	500	750	1200	80°	106	228,6	-	281,2	375,6

1 : Maximaal gewicht vleugel
Poids max. ouvrant
Maximal Gewicht Flügel
Max. vent weight

3 : Maximale hoogte vleugel
Hauteur max. ouvrant
Max. Höhe Flügel
Max. vent height

2 : Minimale hoogte vleugel
Hauteur min. ouvrant
Min. Höhe Flügel
Min. vent height

4 : Maximale breedte vleugel
Largeur max. ouvrant
max. Breite Flügel
Max. vent width

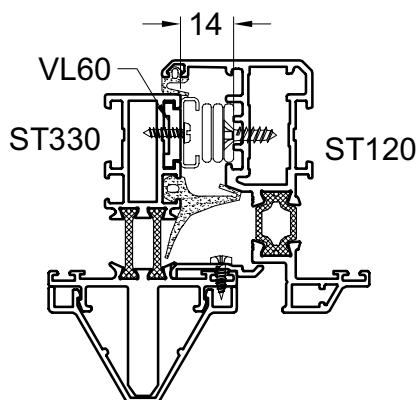
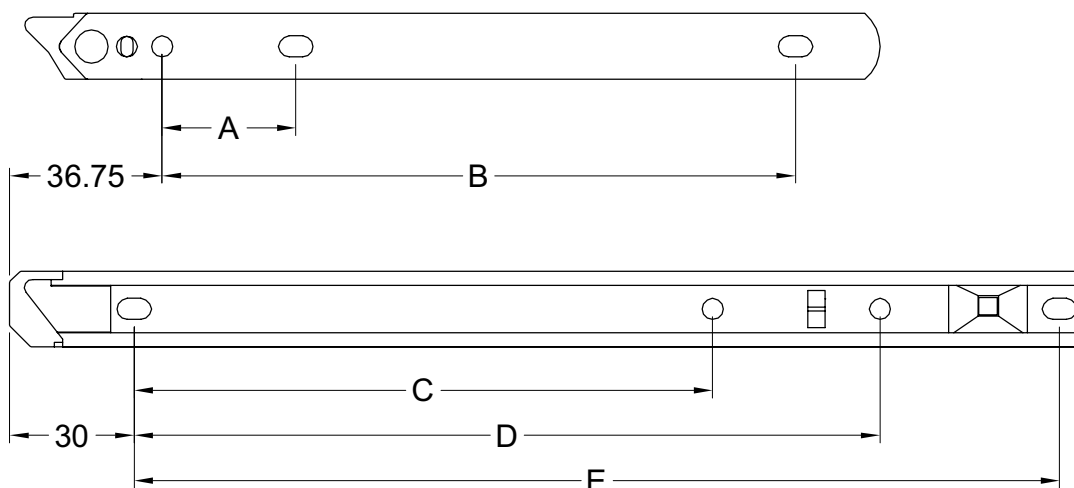

schaar

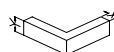

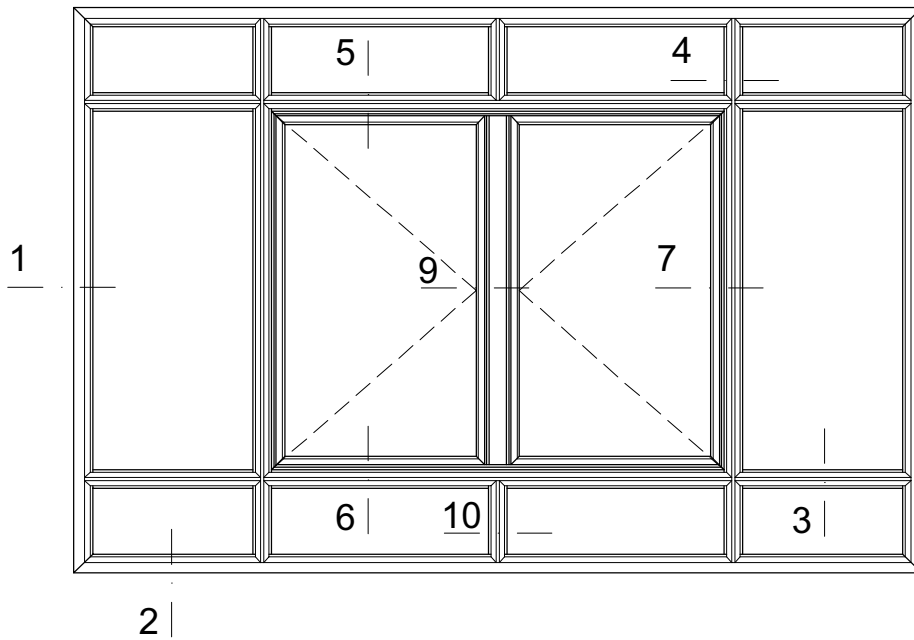
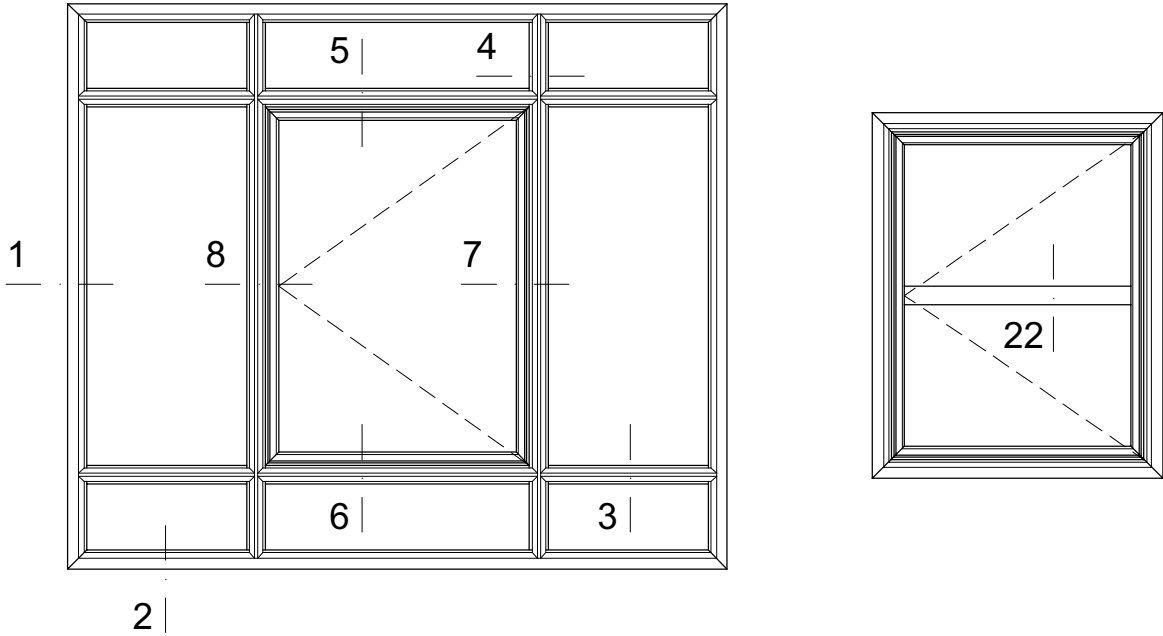

doortyp

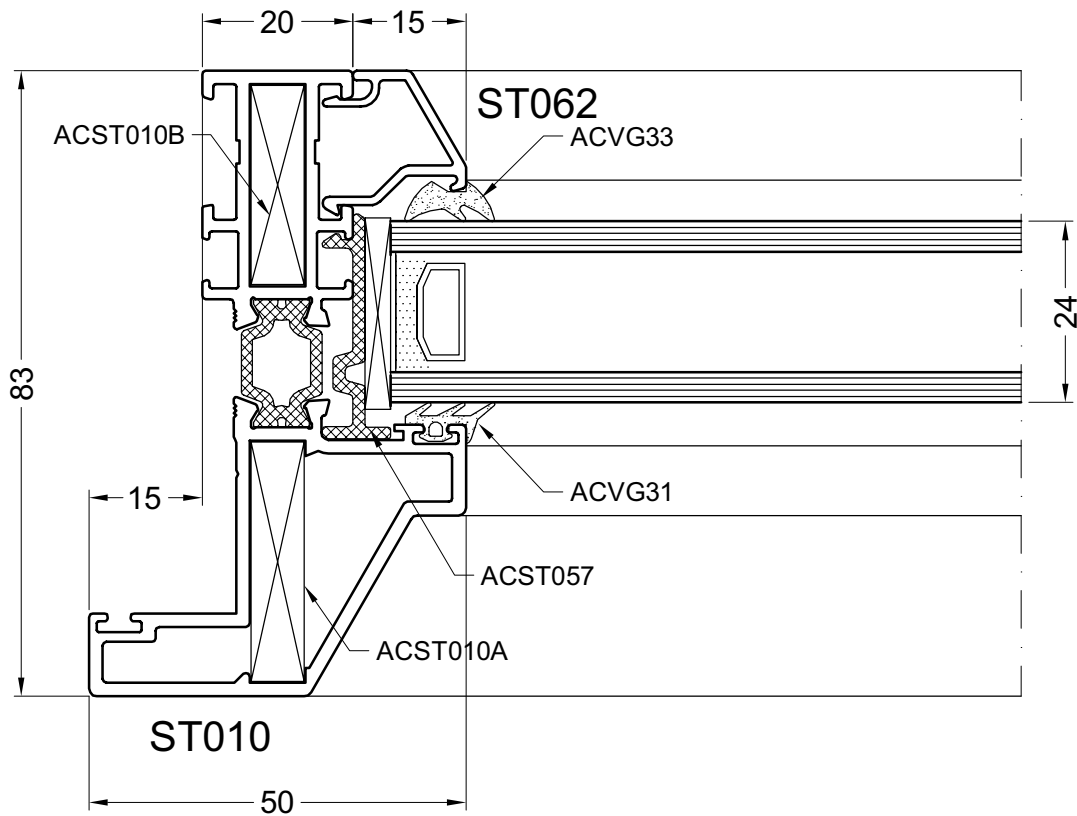
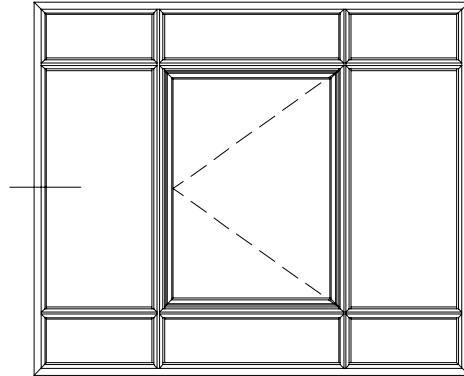

door01a

2A

DOORSNEDE - COUPE - SCHNITT - SECTION

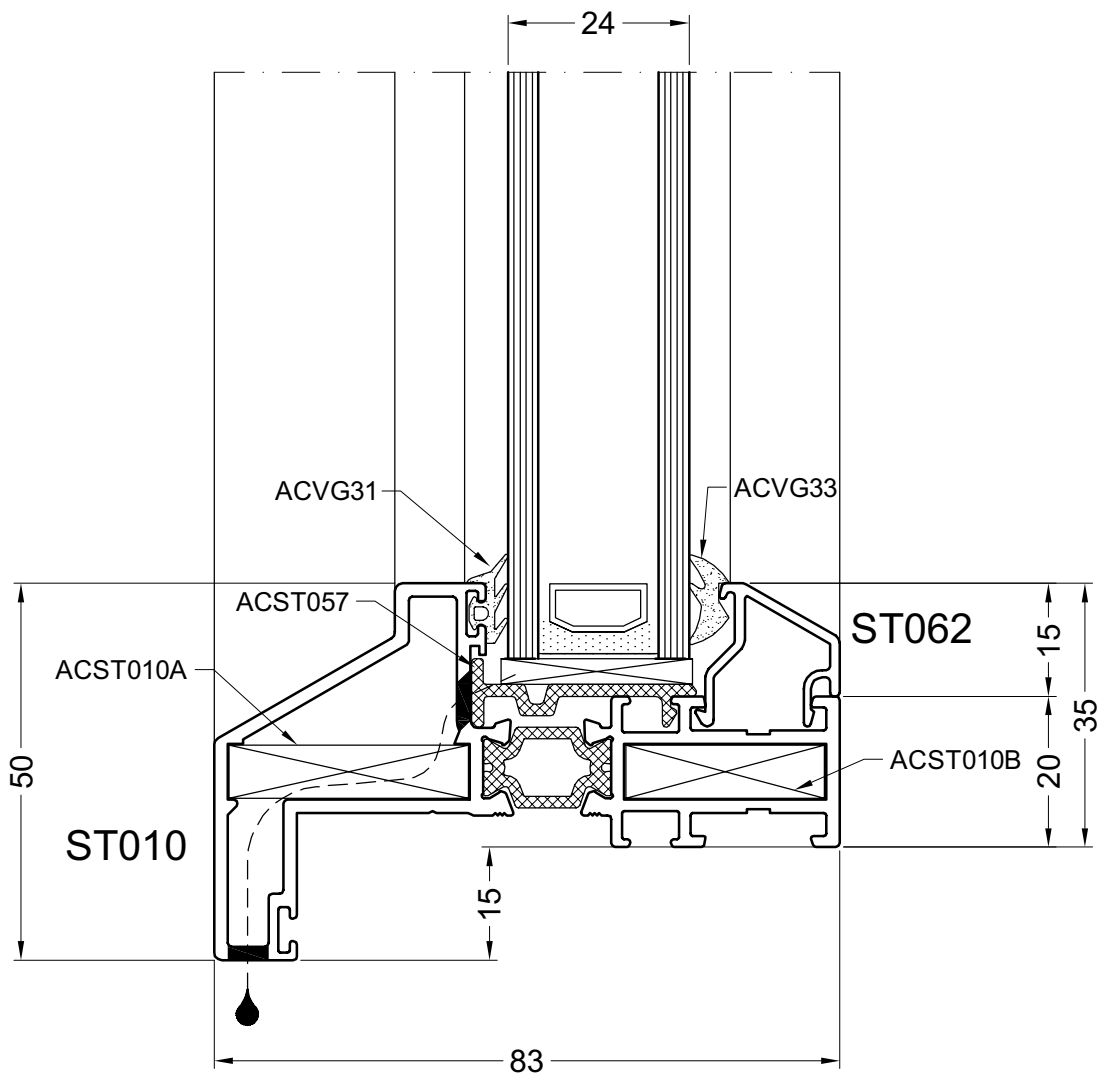
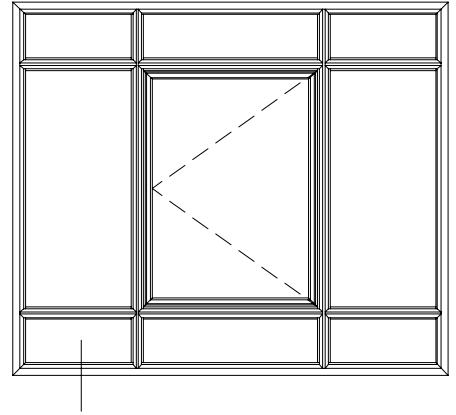

door02a

2B

DOORSNEDE - COUPE - SCHNITT - SECTION

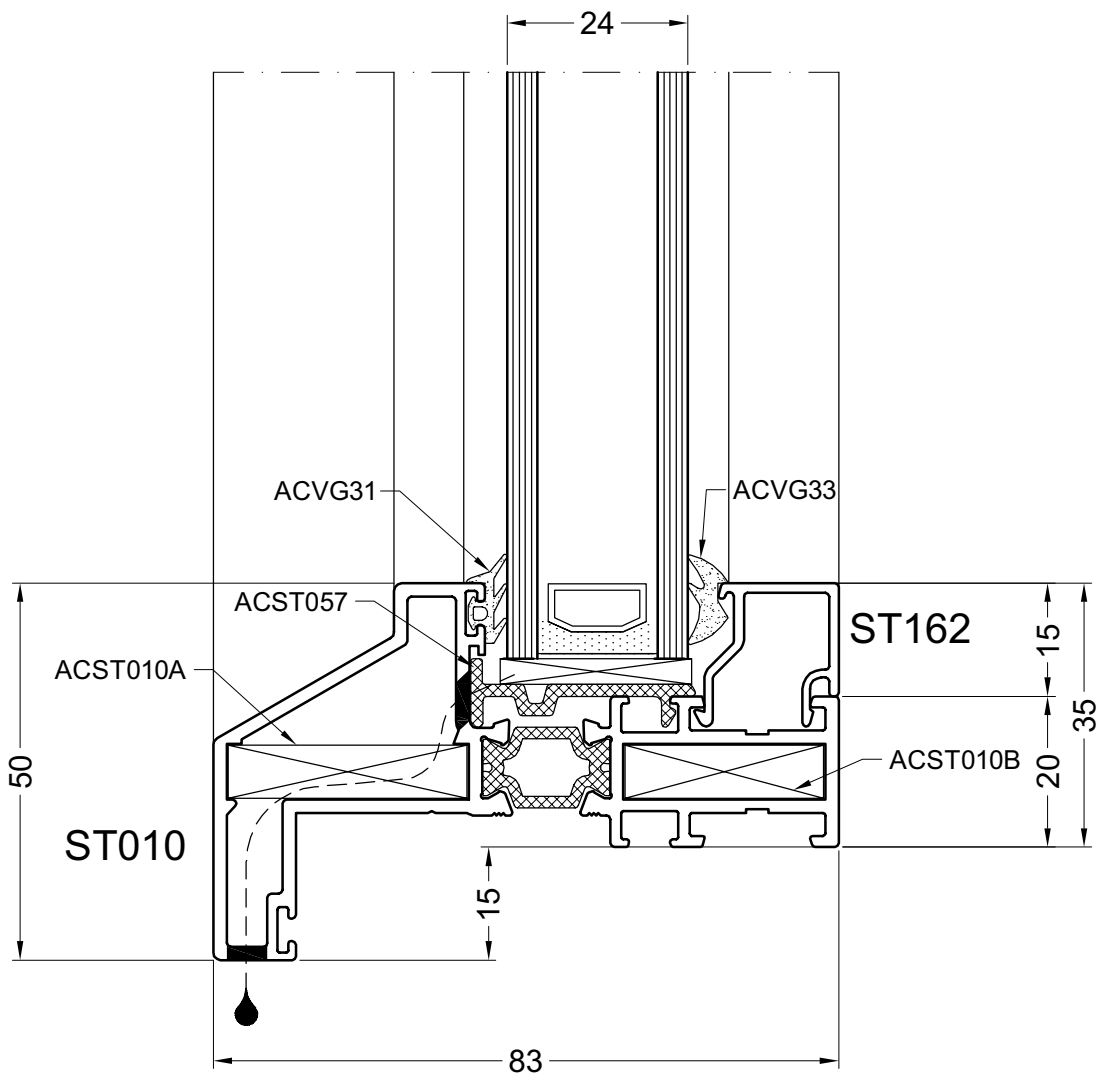
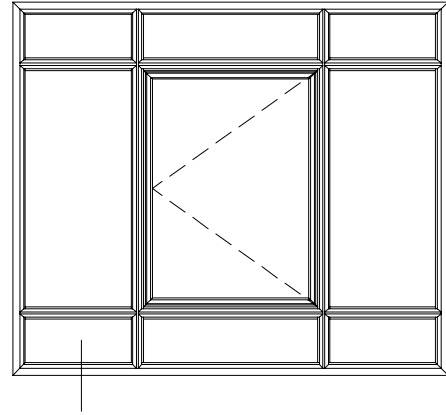

door02b

2C

DOORSNEDE - COUPE - SCHNITT - SECTION

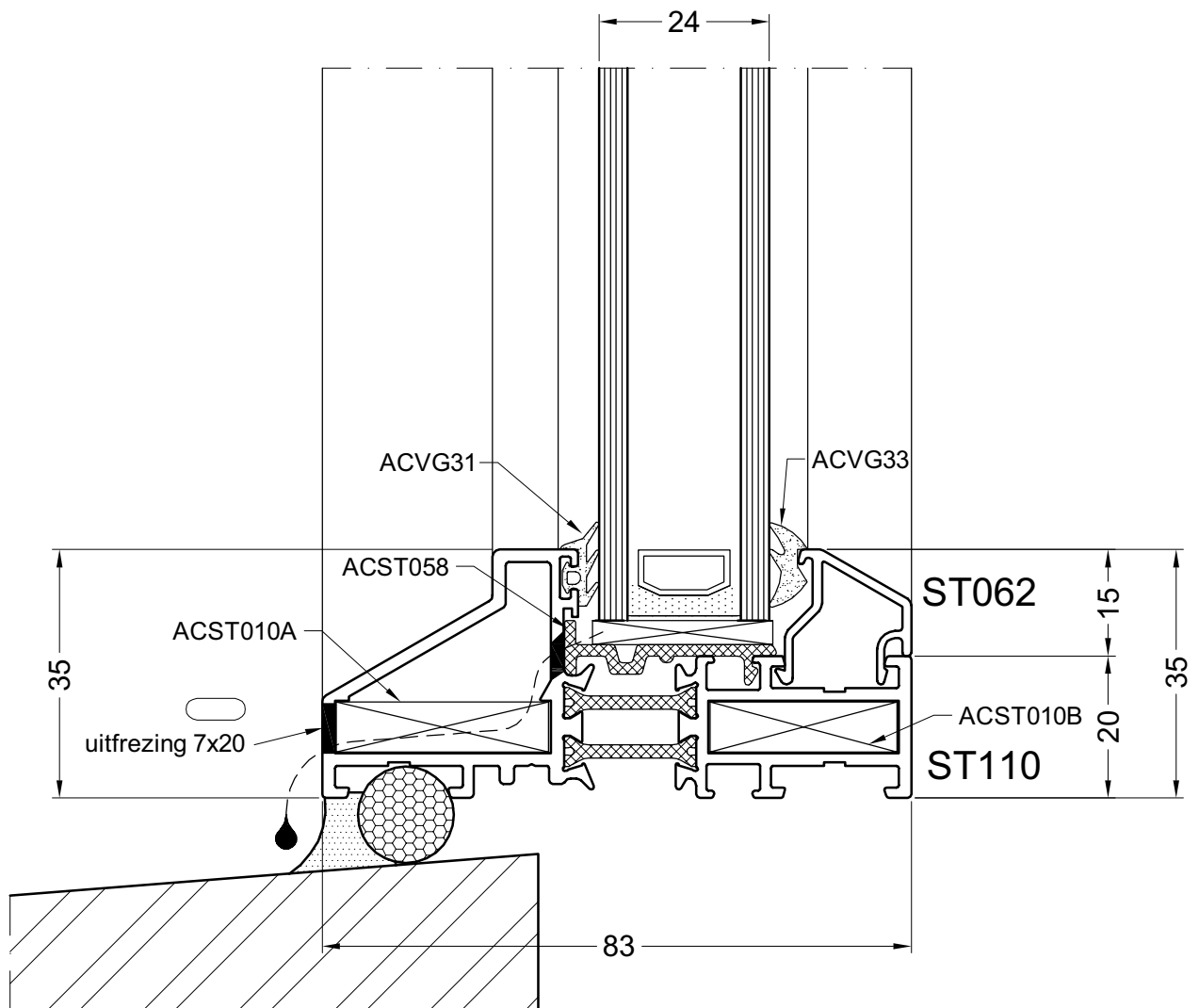
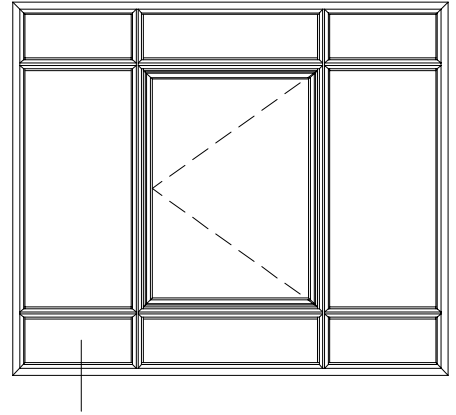

door02c

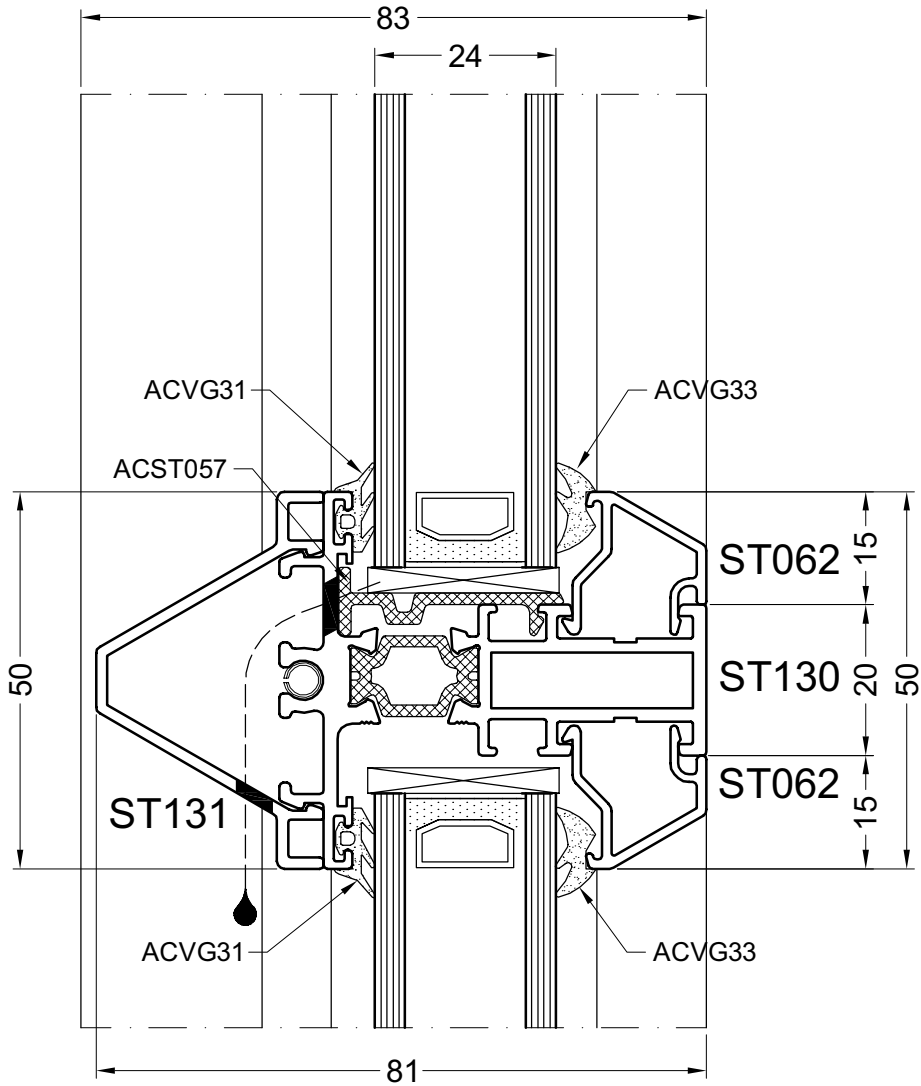
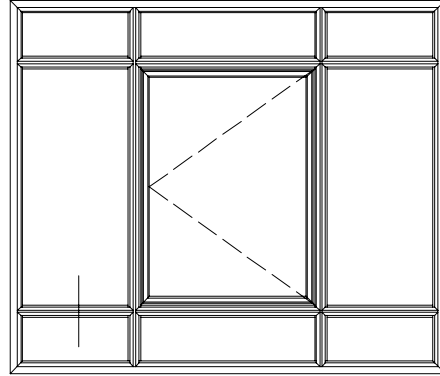

door03a

4A

DOORSNEDE - COUPE - SCHNITT - SECTION

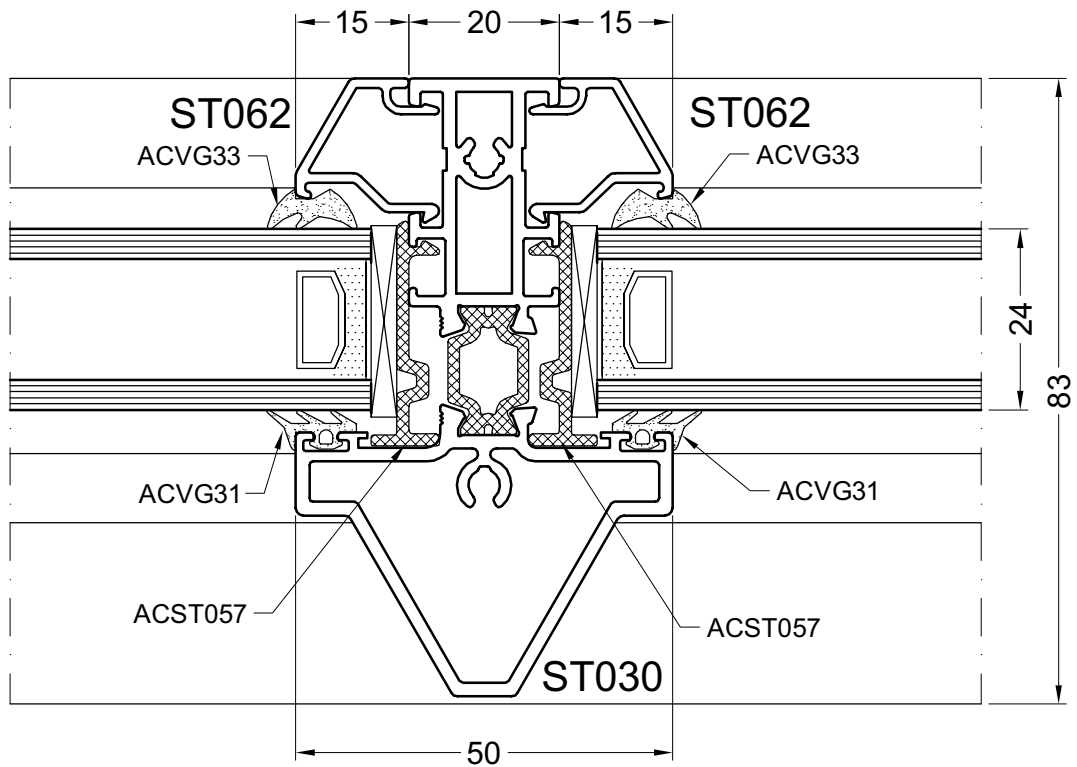
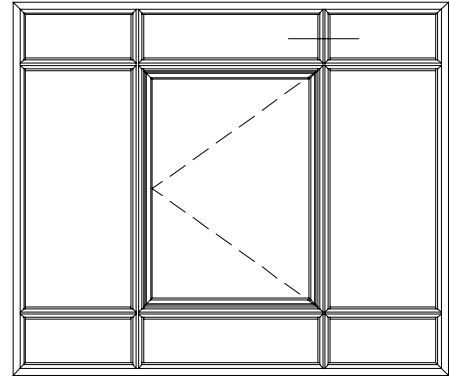

door04a

4B

DOORSNEDE - COUPE - SCHNITT - SECTION

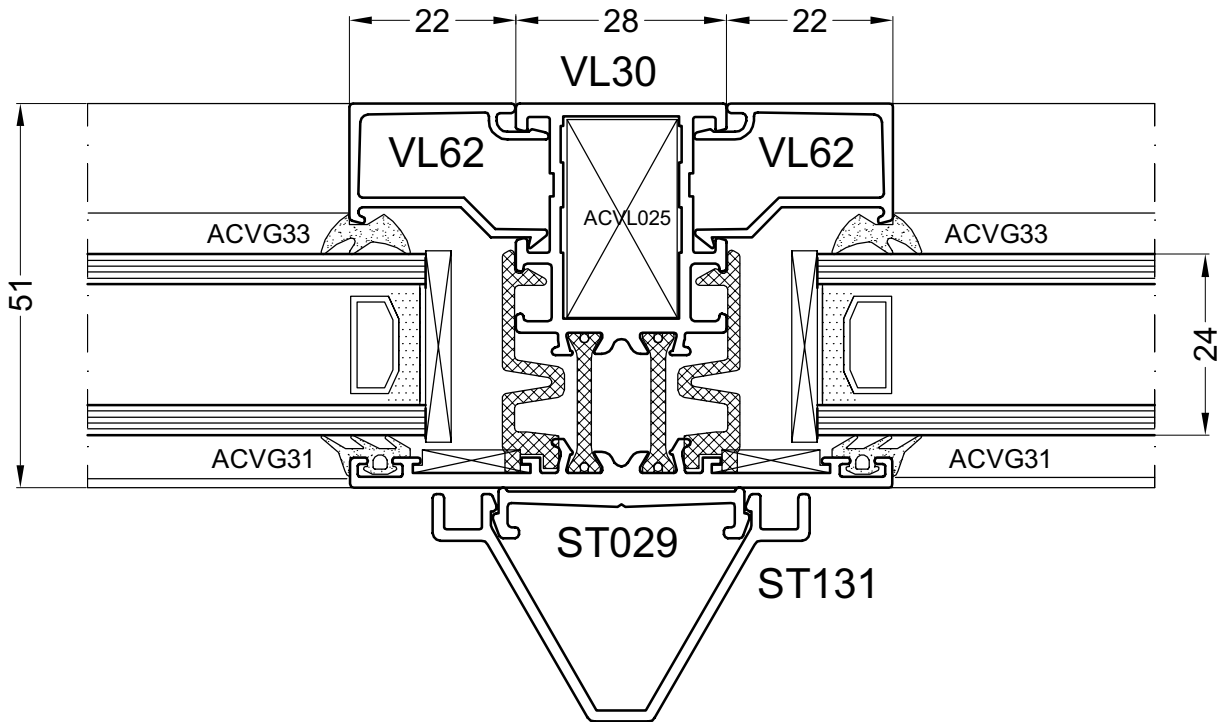
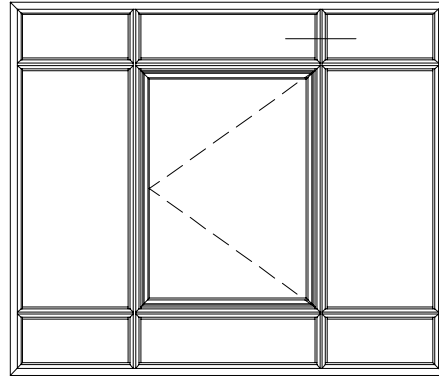

door04b

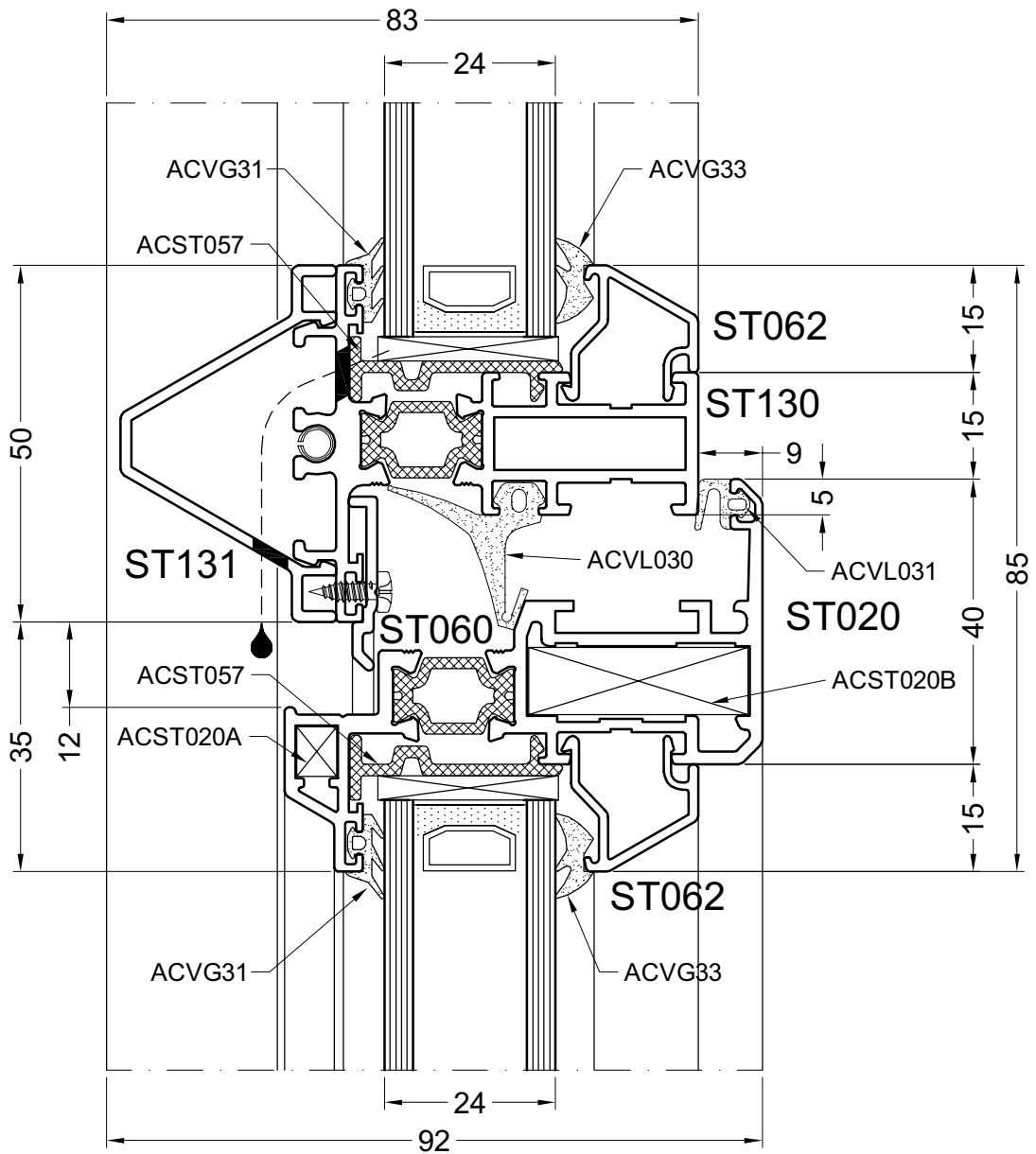
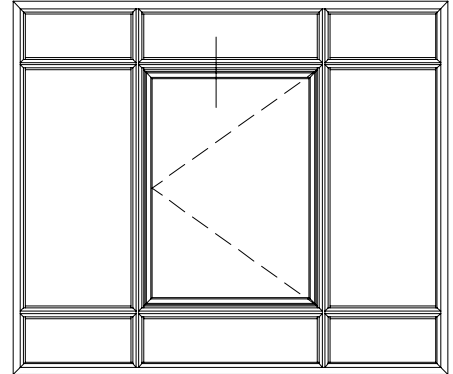

door05a

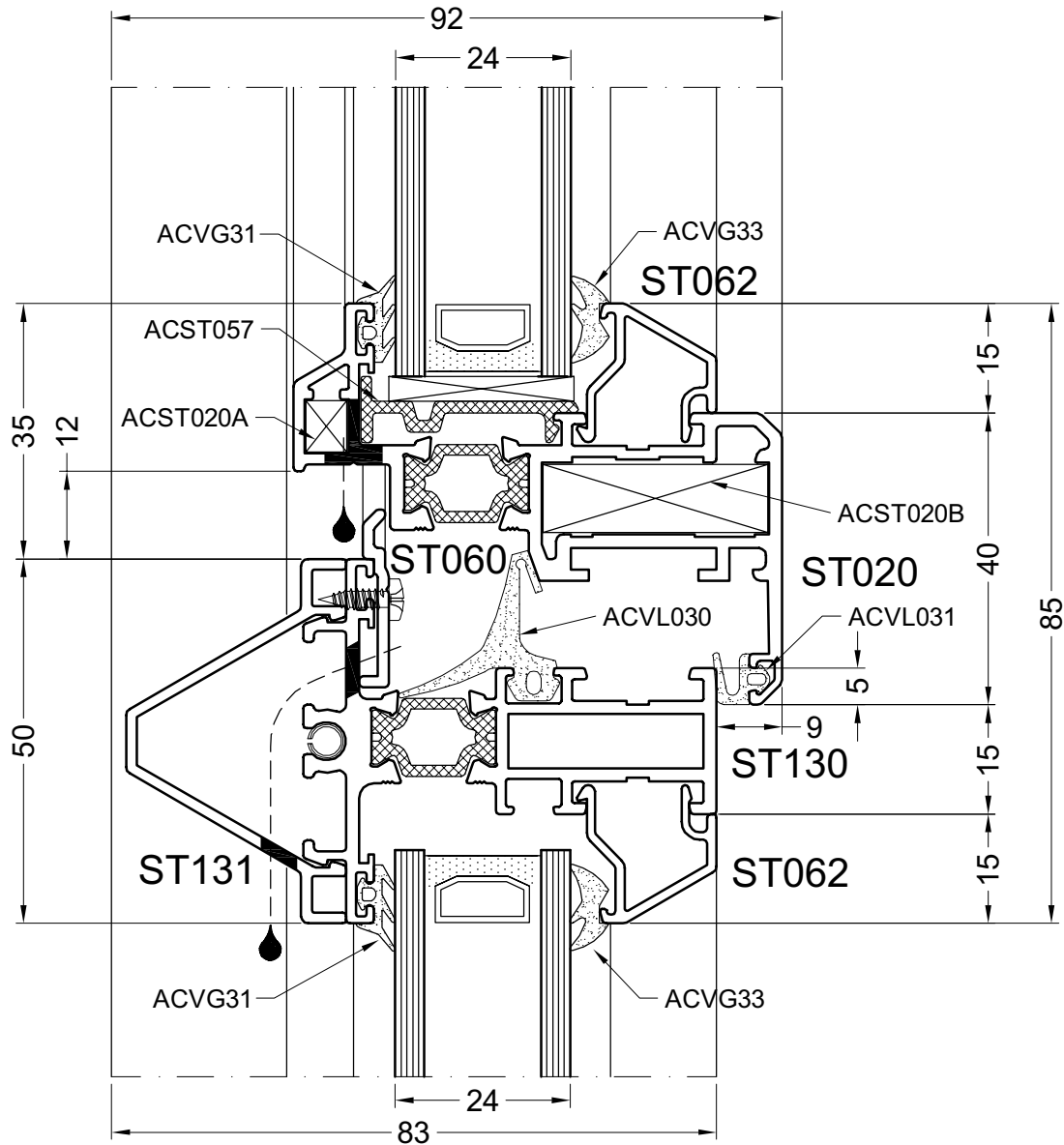
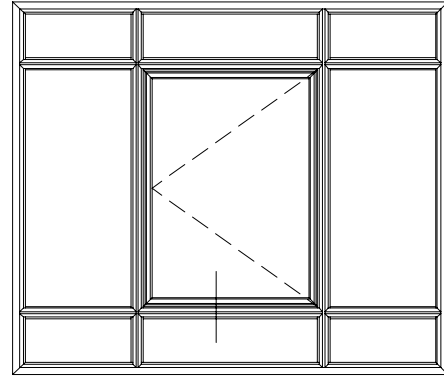

door06a

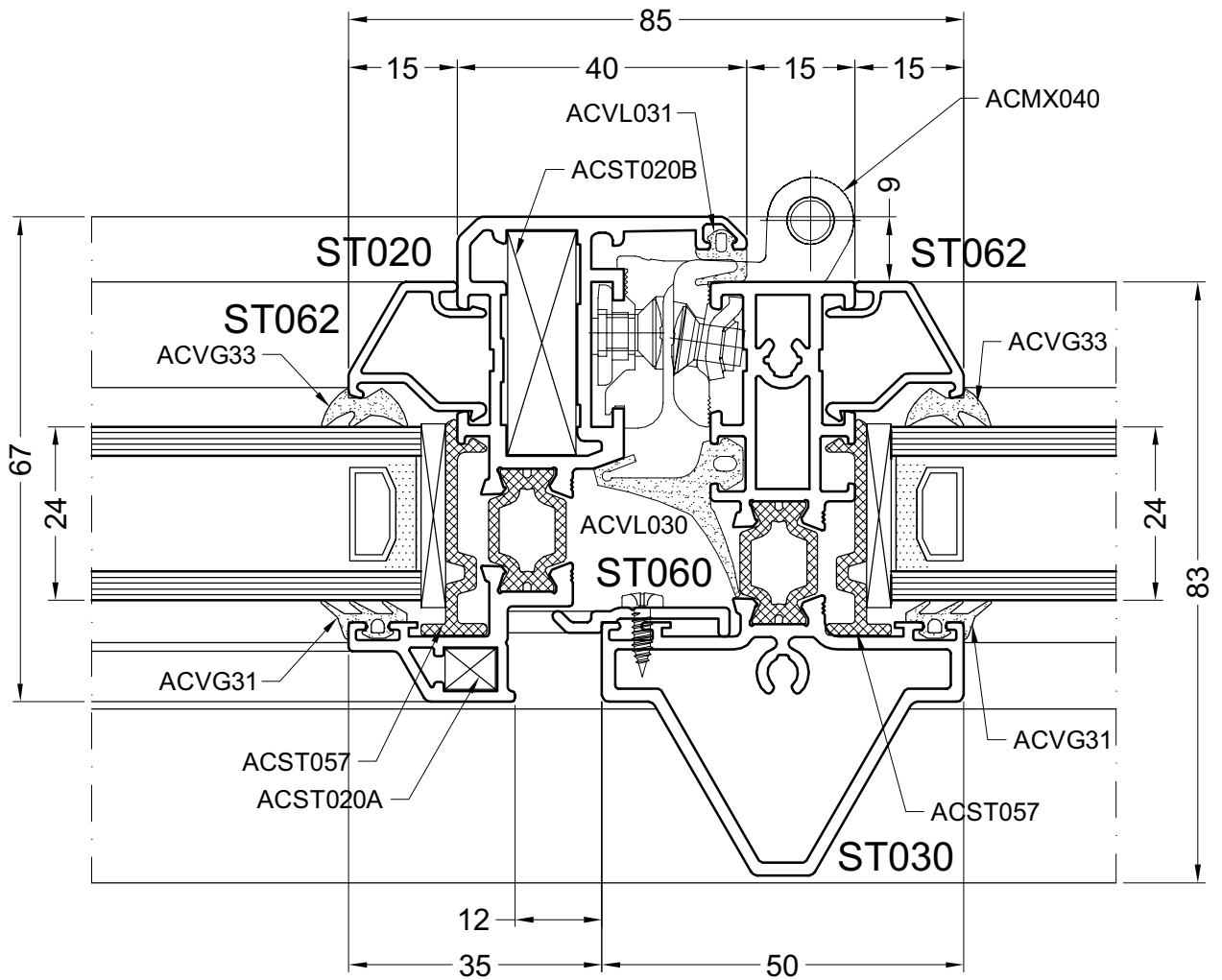
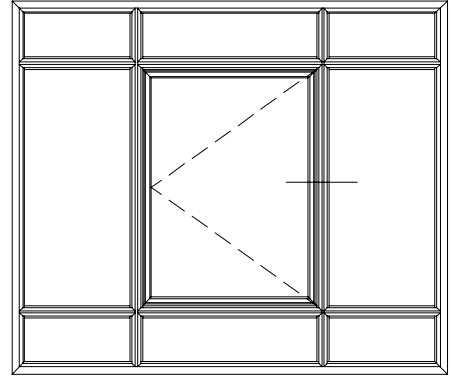

door07a

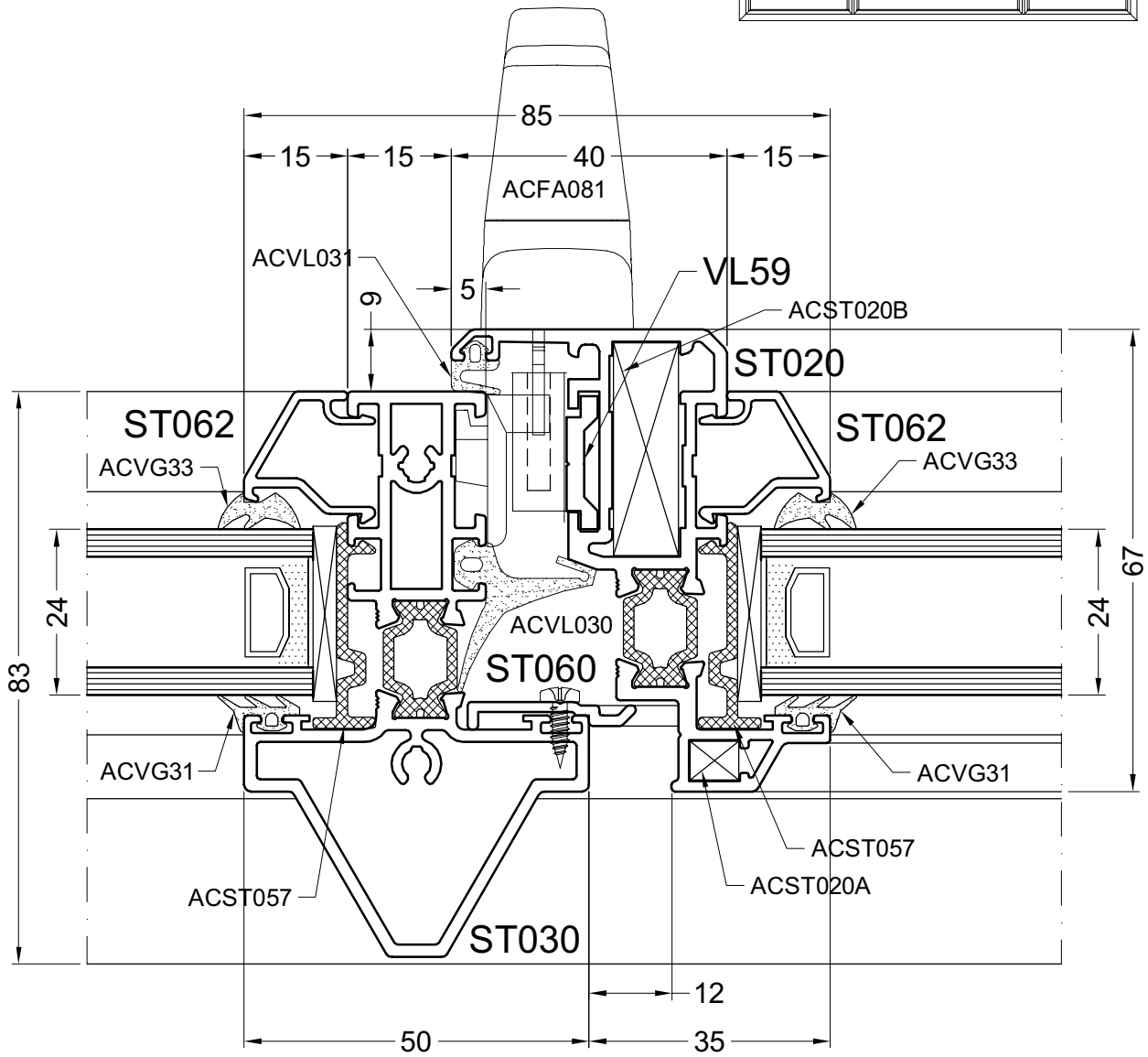
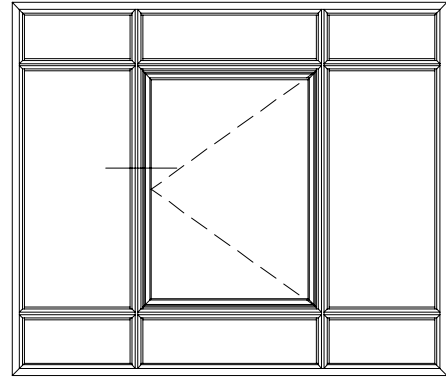

door08a

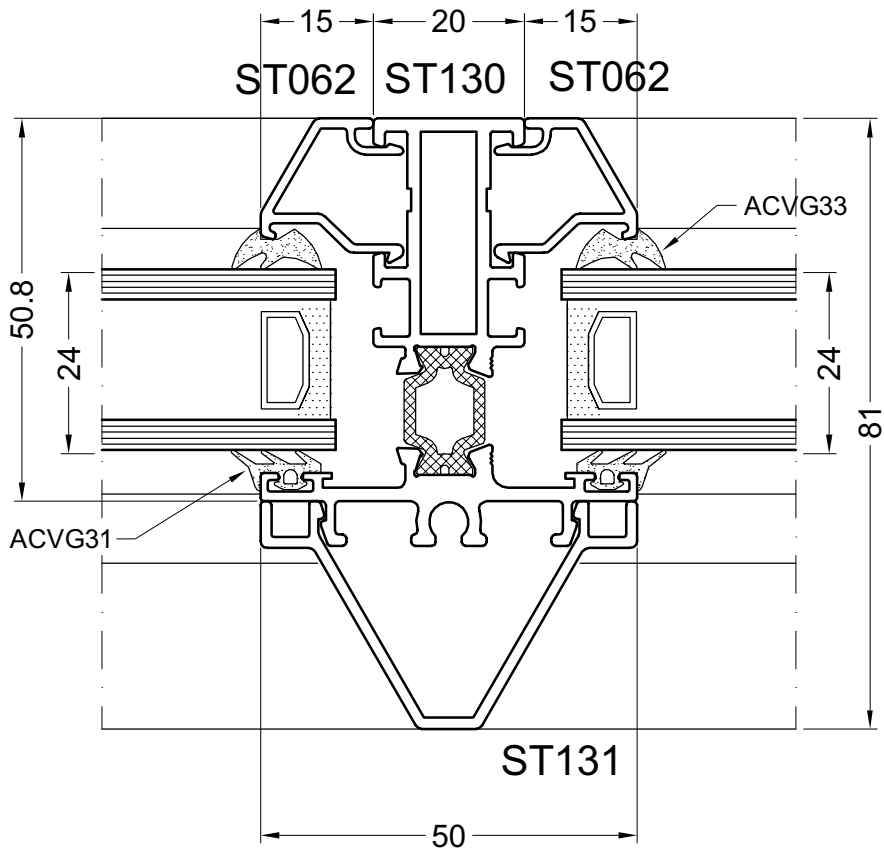
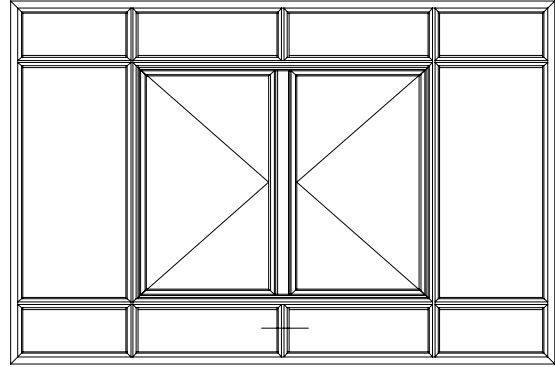

DOORSNEDE - COUPE - SCHNITT - SECTION

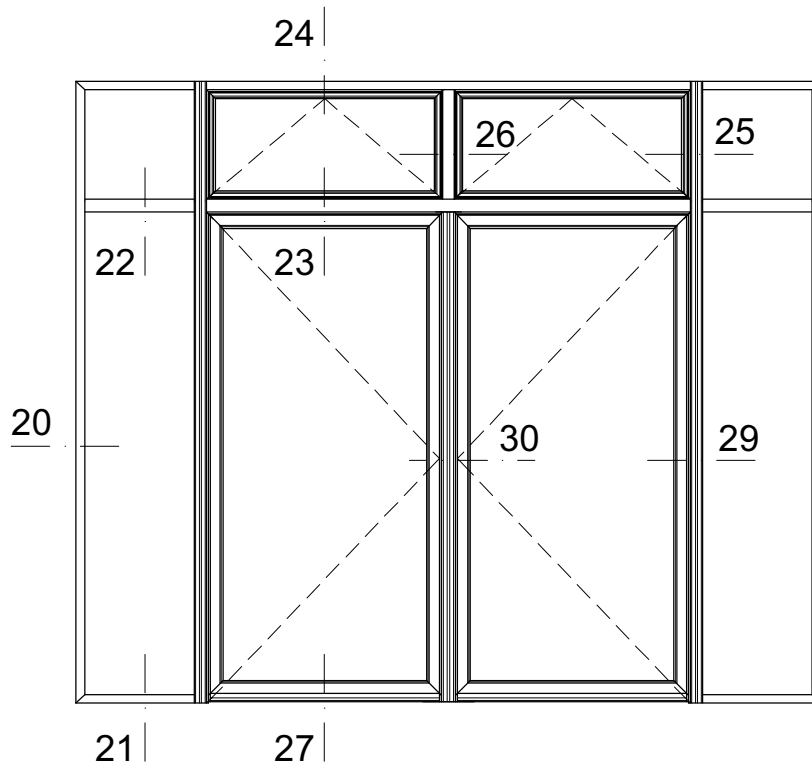
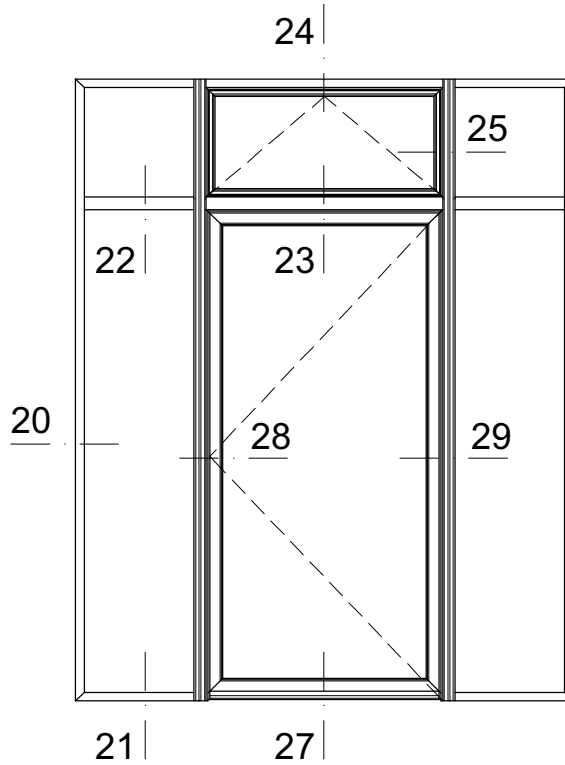

doortyp2

20A

DOORSNEDE - COUPE - SCHNITT - SECTION

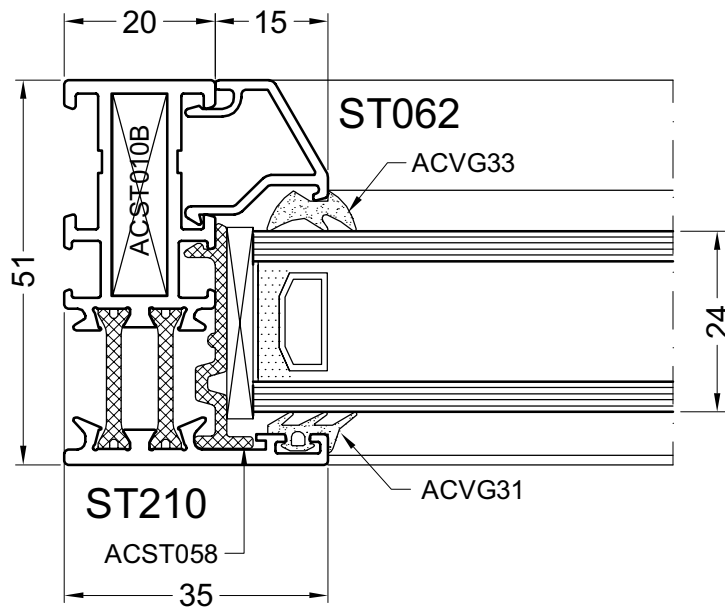
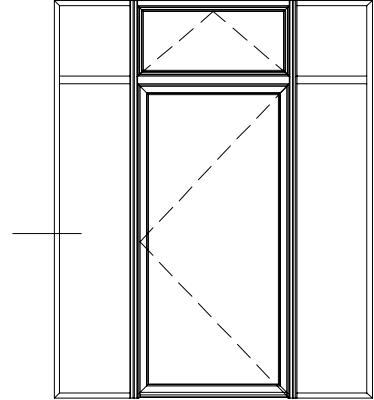

door20

20B

DOORSNEDE - COUPE - SCHNITT - SECTION

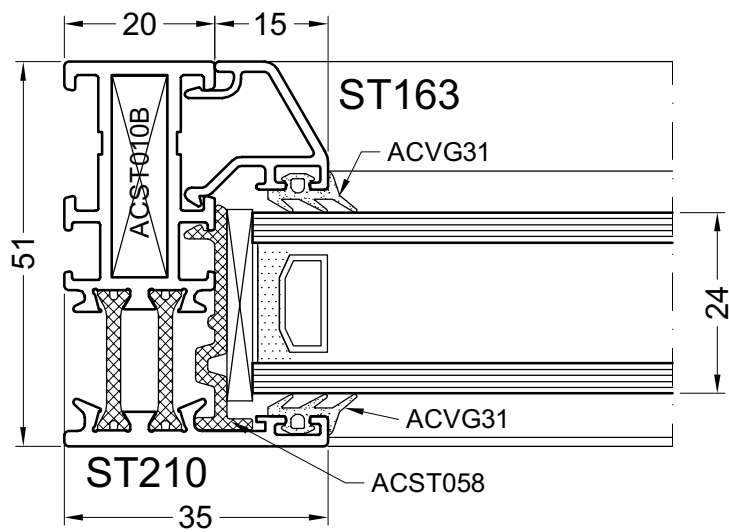
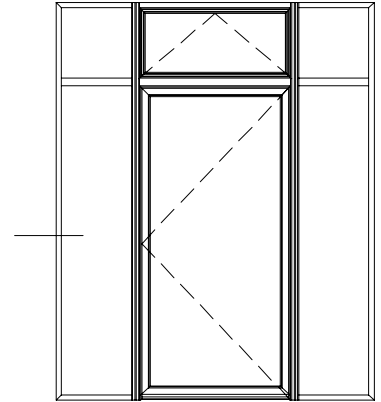

door20b

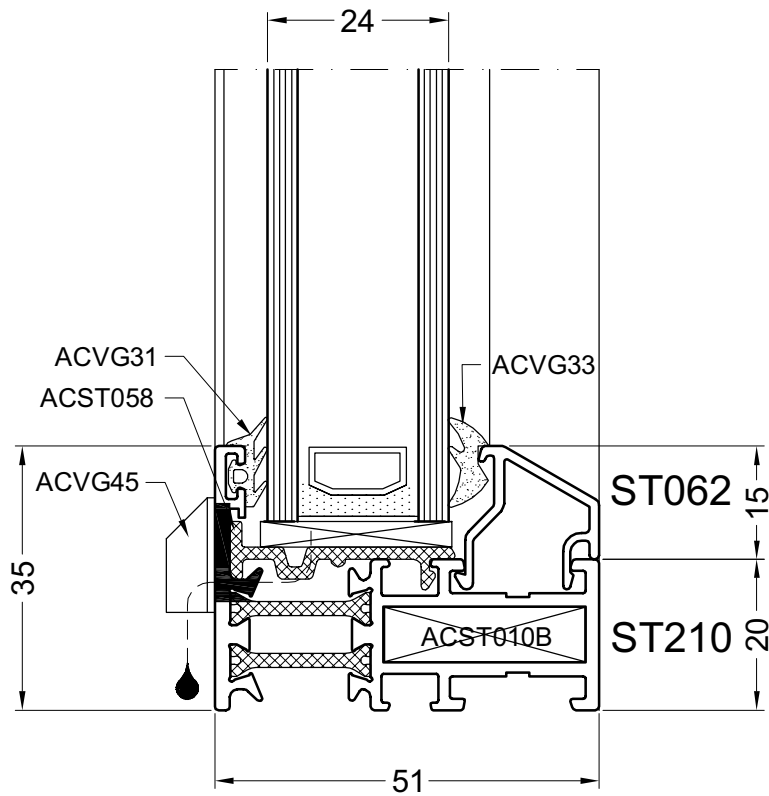
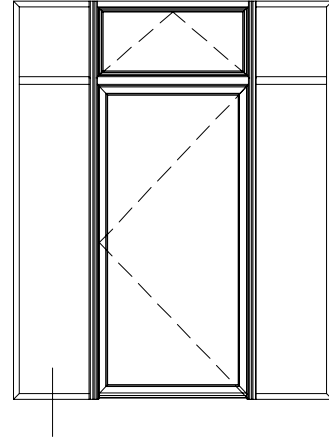

door21

22

DOORSNEDE - COUPE - SCHNITT - SECTION

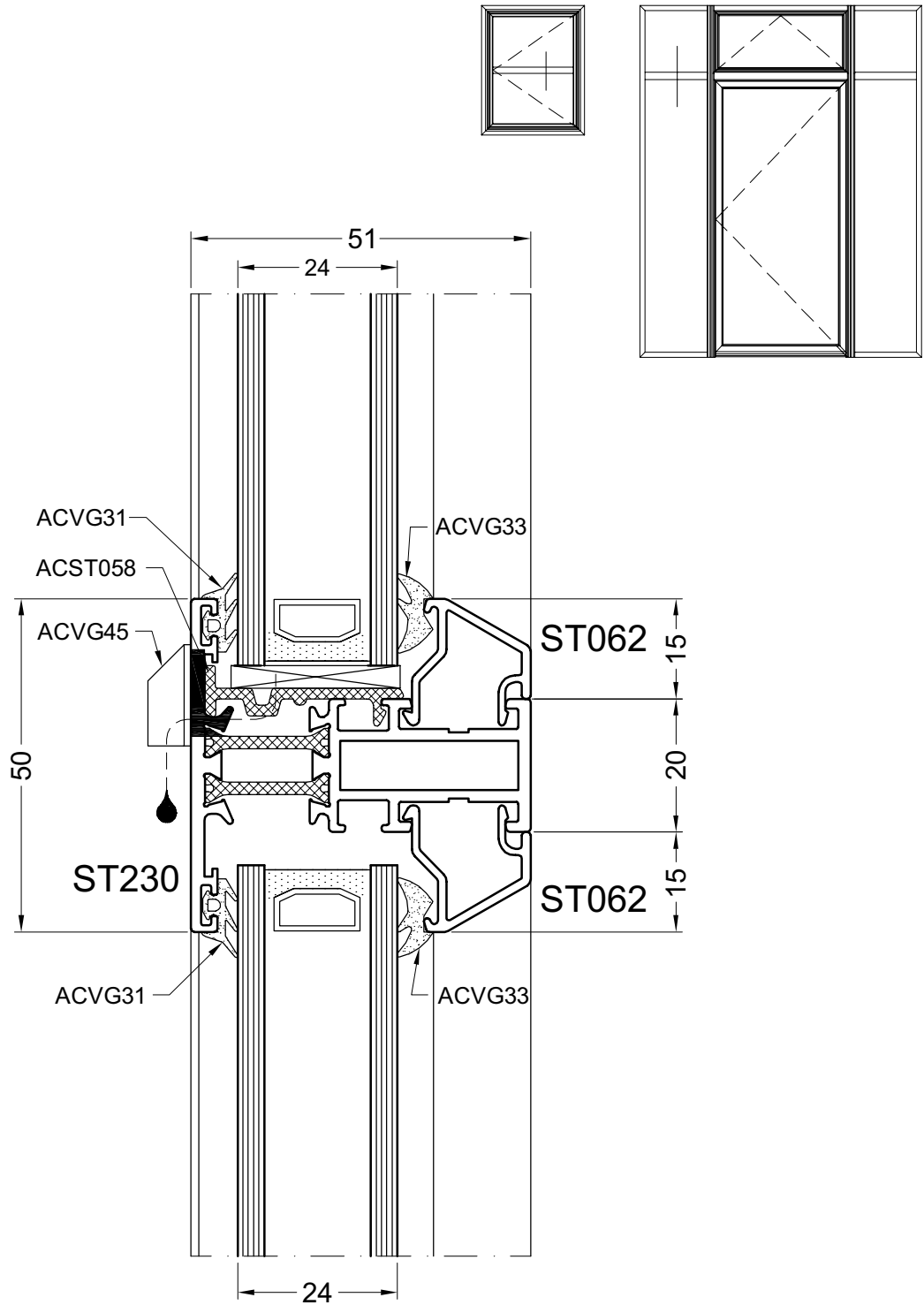

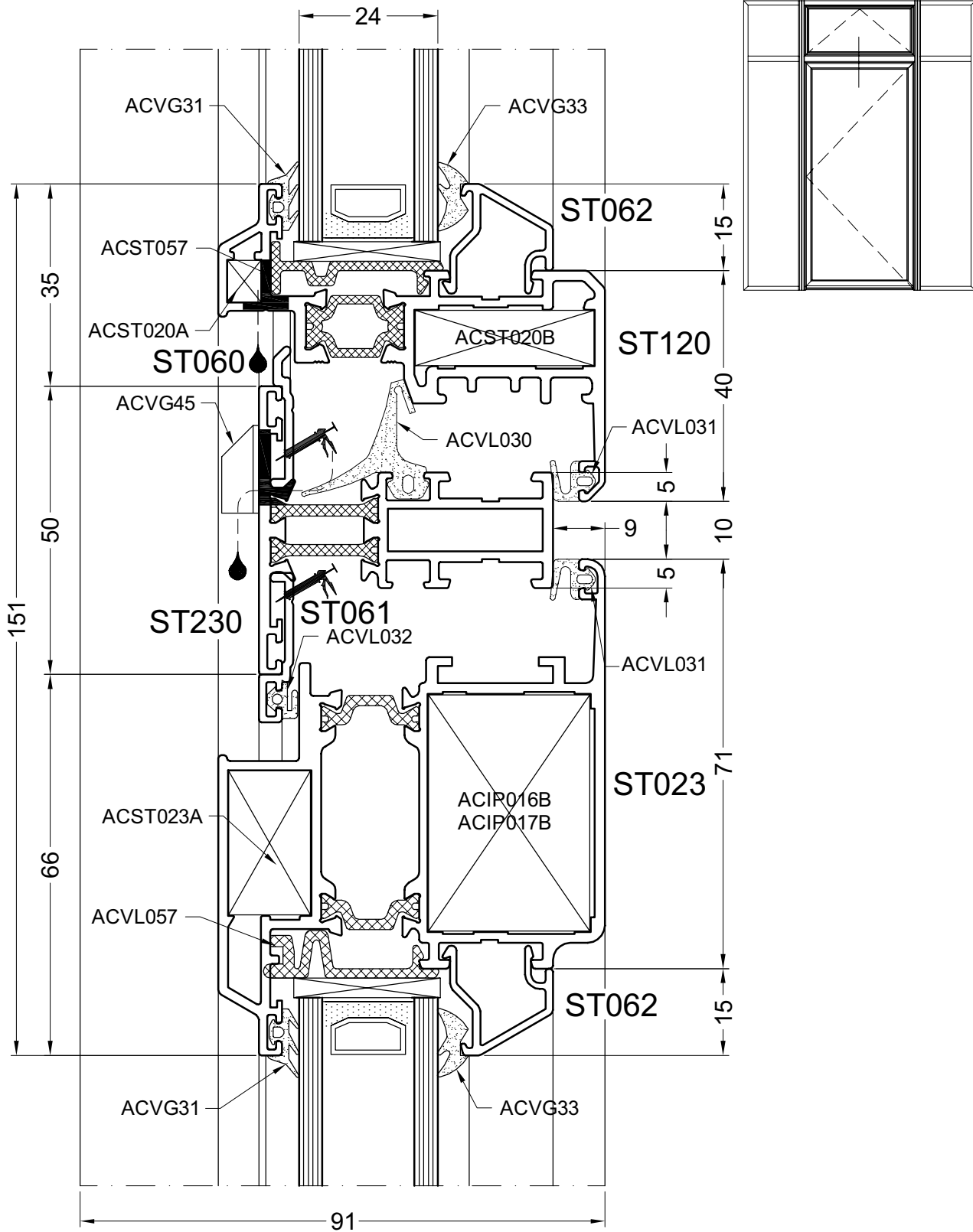

door23

24

DOORSNEDE - COUPE - SCHNITT - SECTION

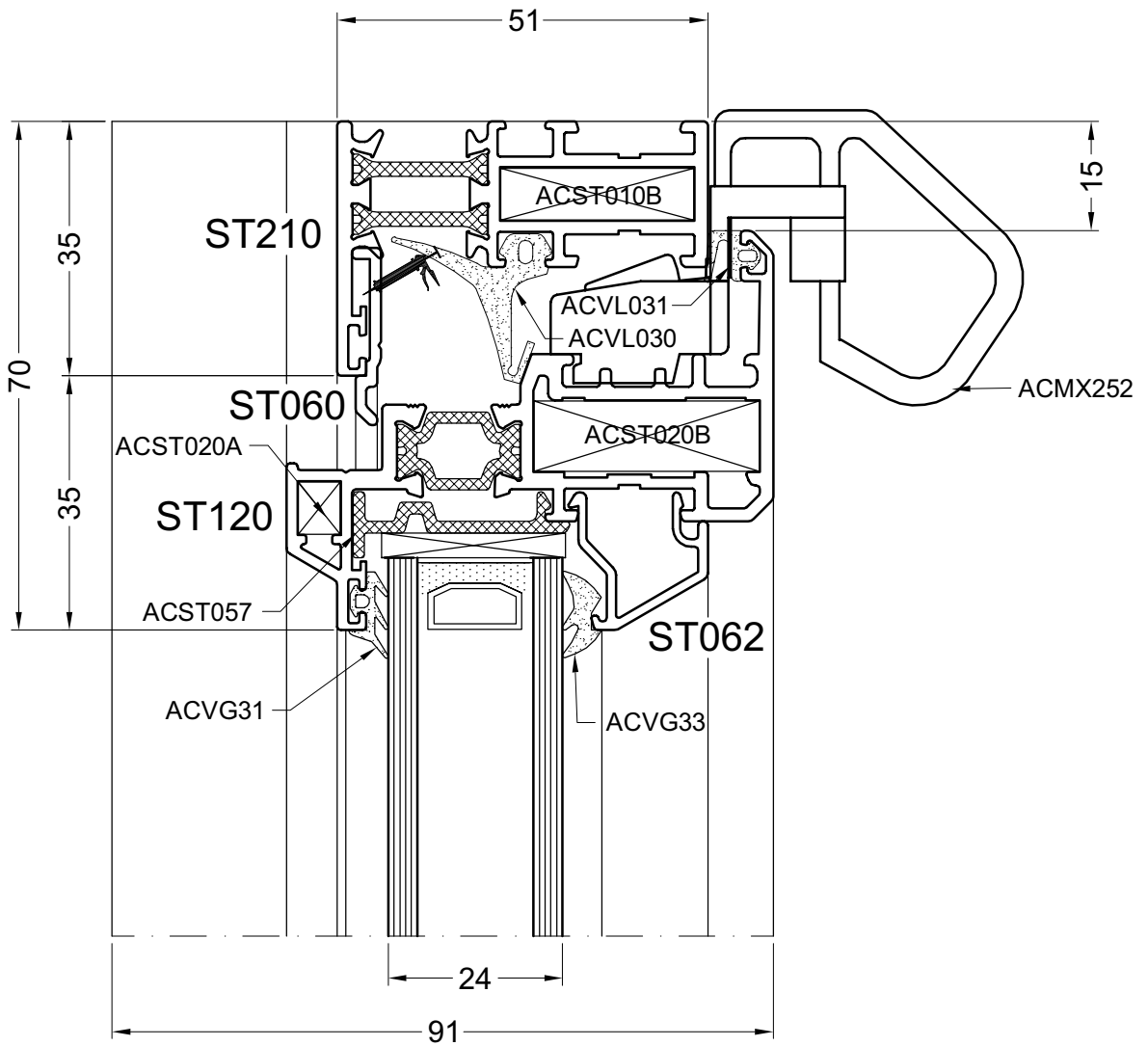
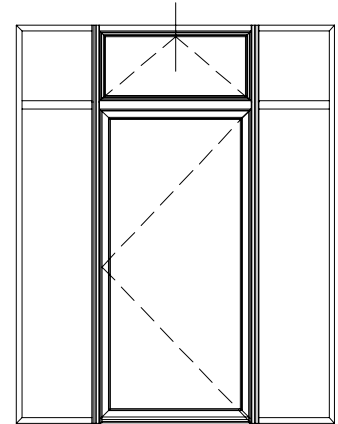

door24

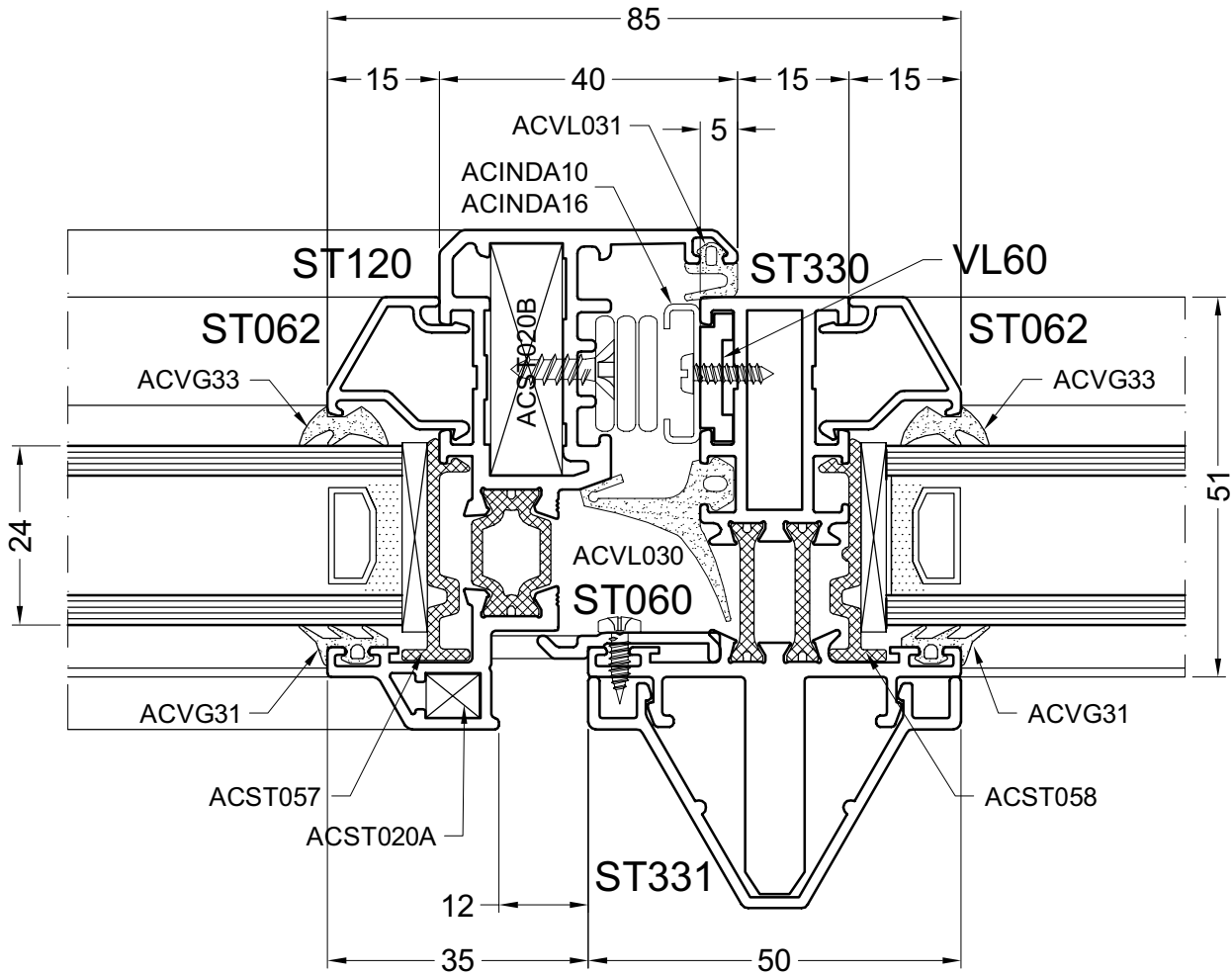
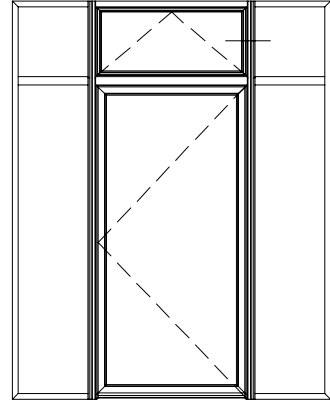

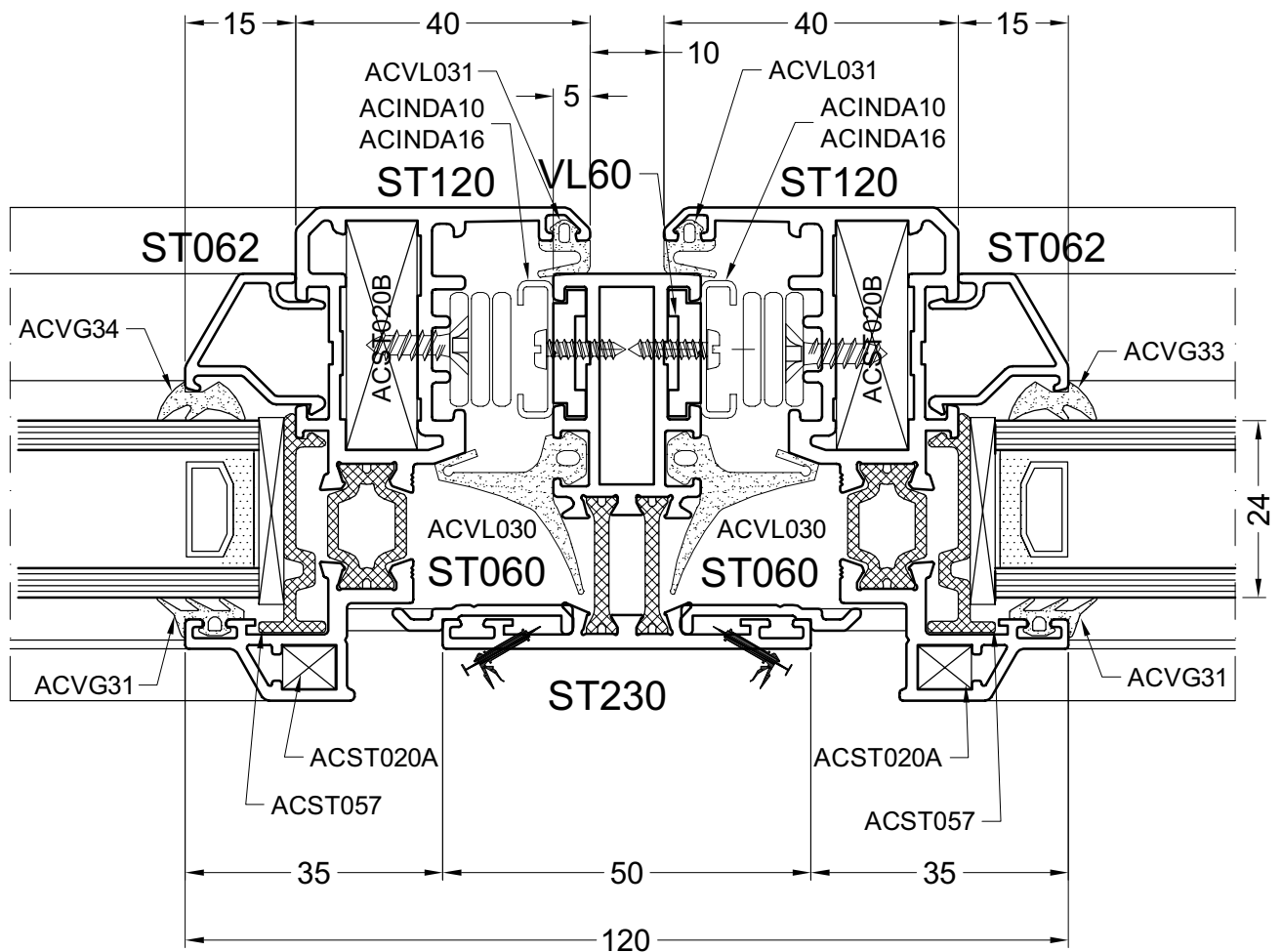
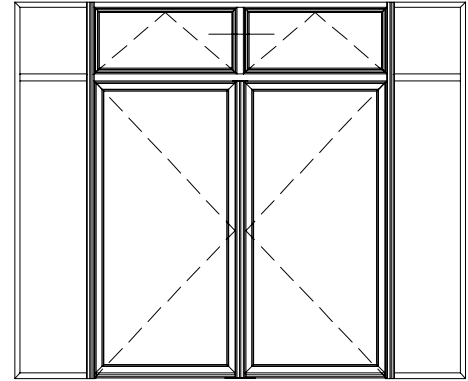

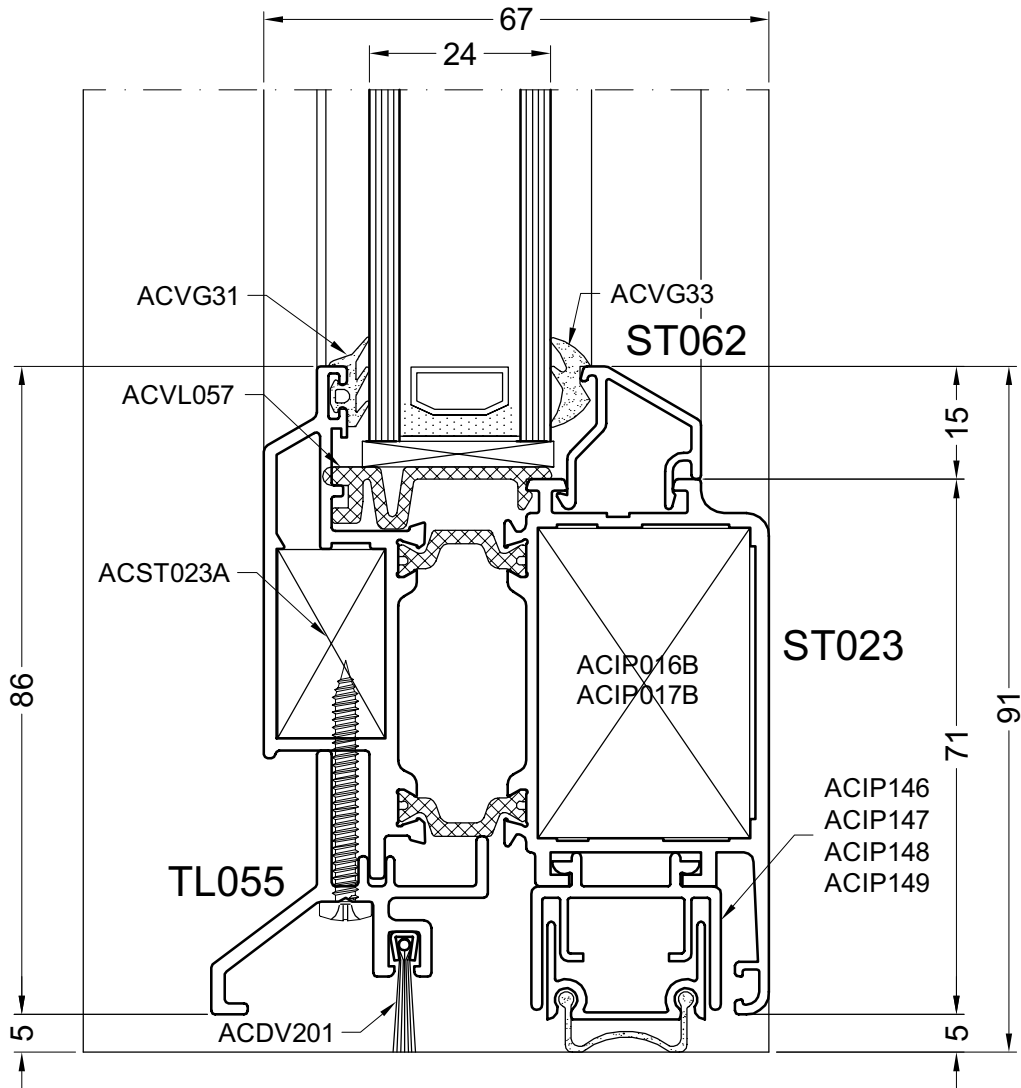
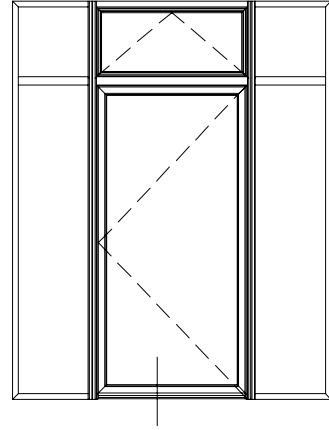

door27

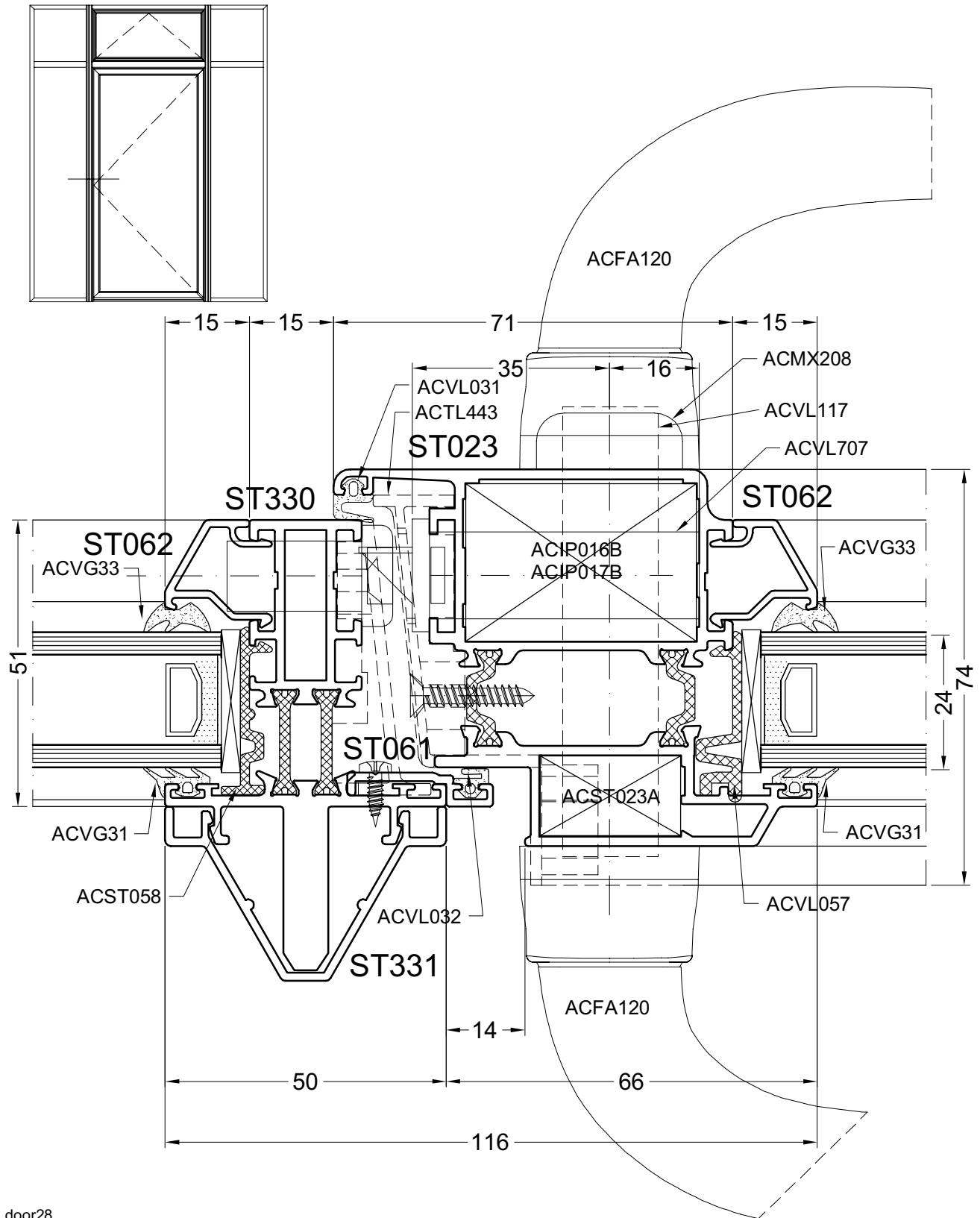

door28

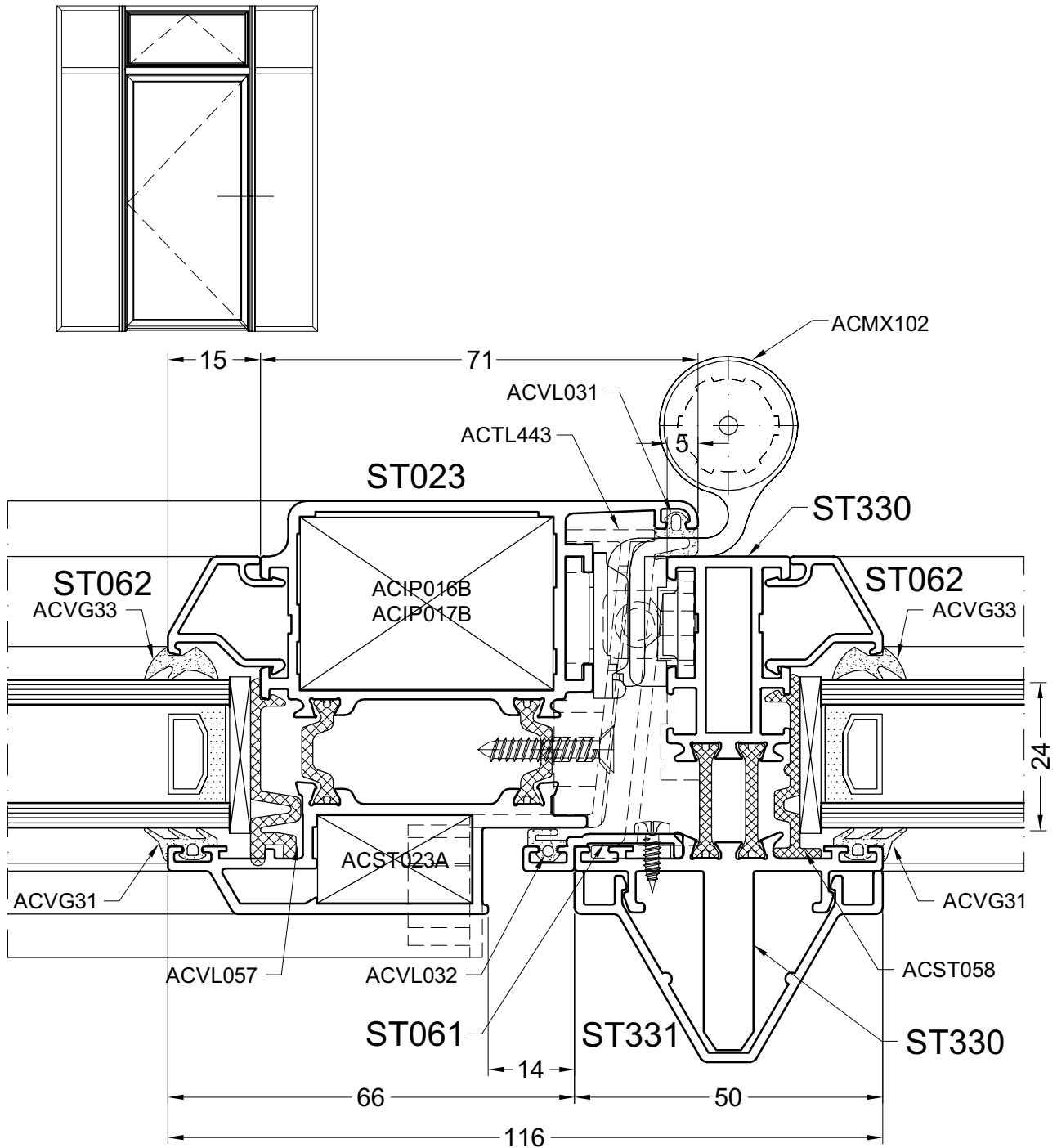

door29

30

DOORSNEDE - COUPE - SCHNITT - SECTION

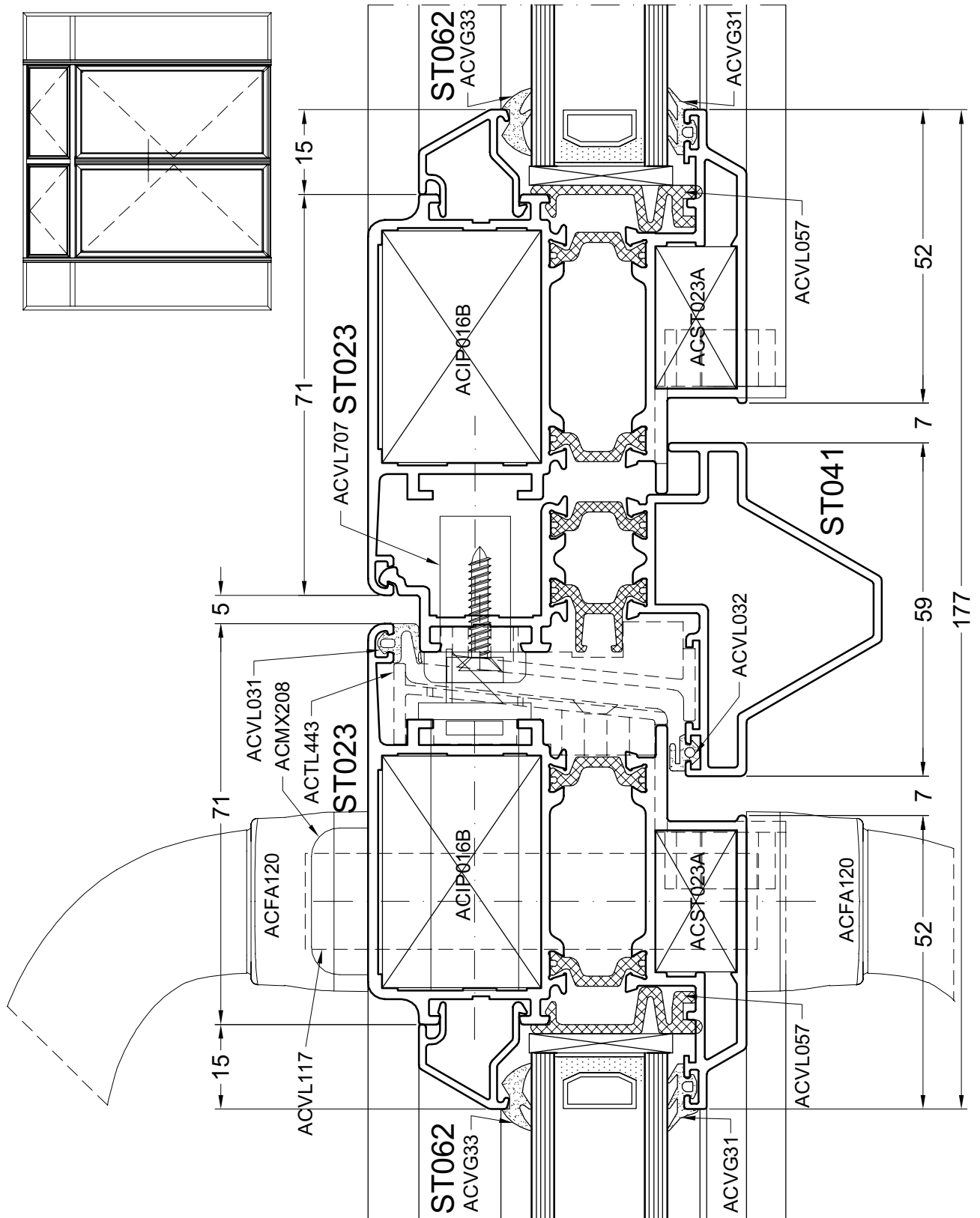

door30

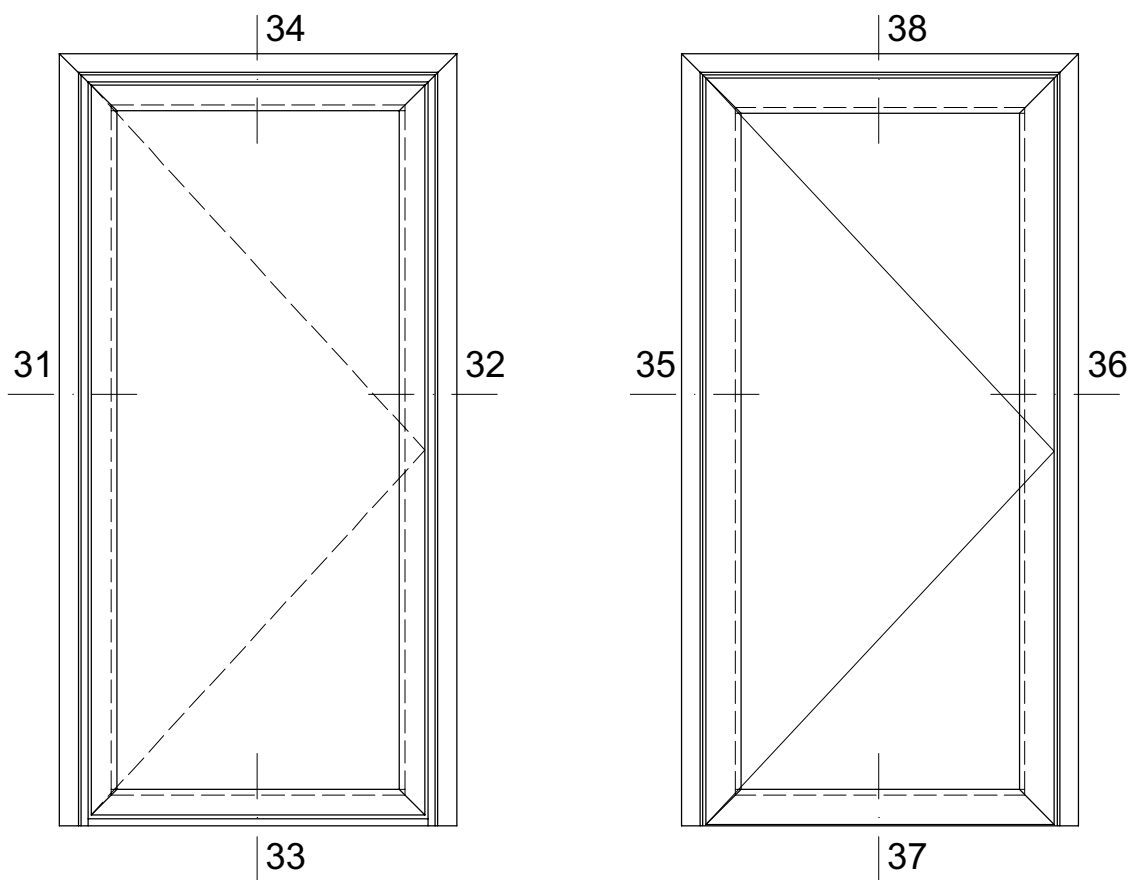

DEURTYP

31

DOORSNEDE - COUPE - SCHNITT - SECTION

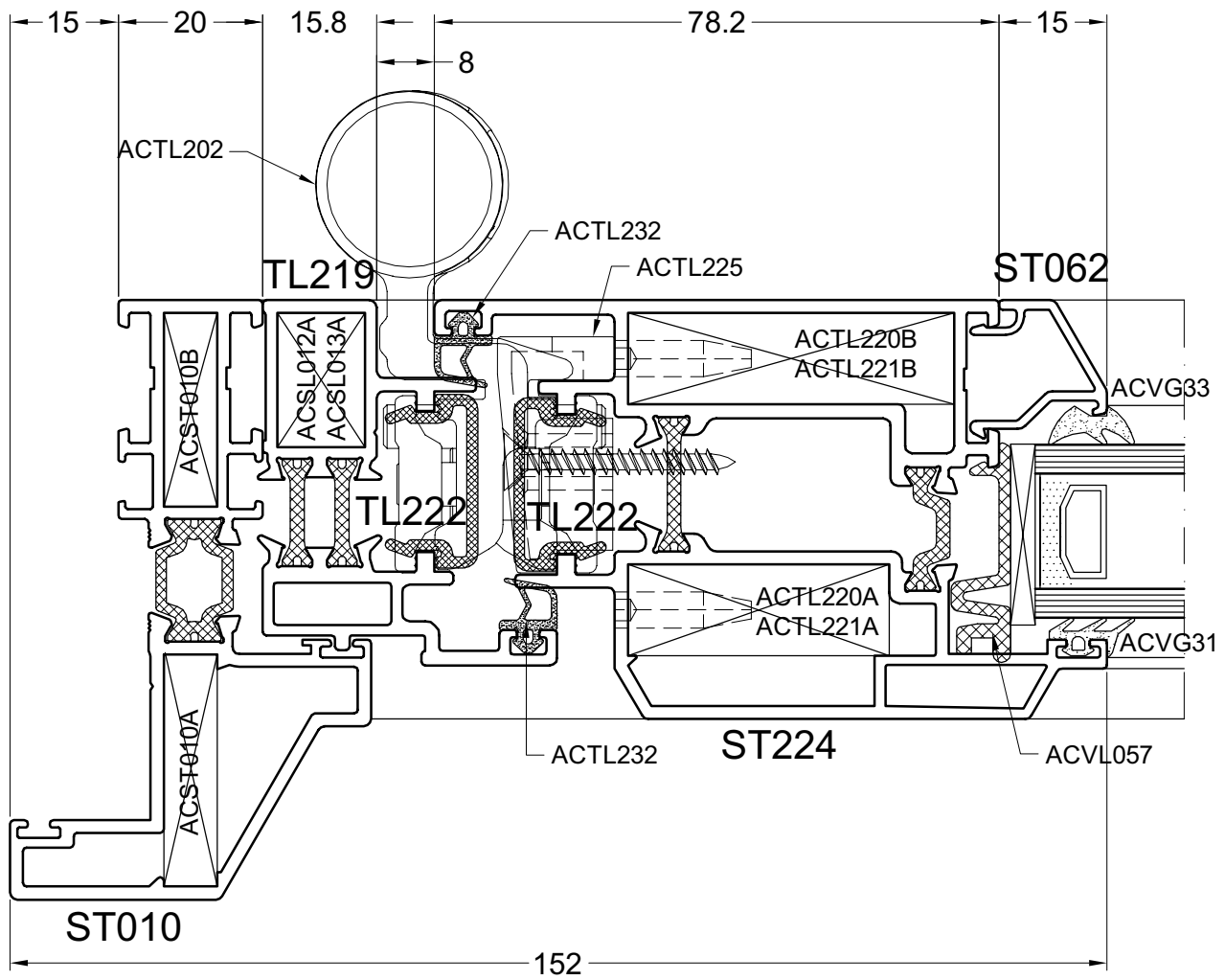
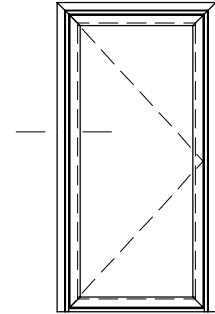

DOOR31

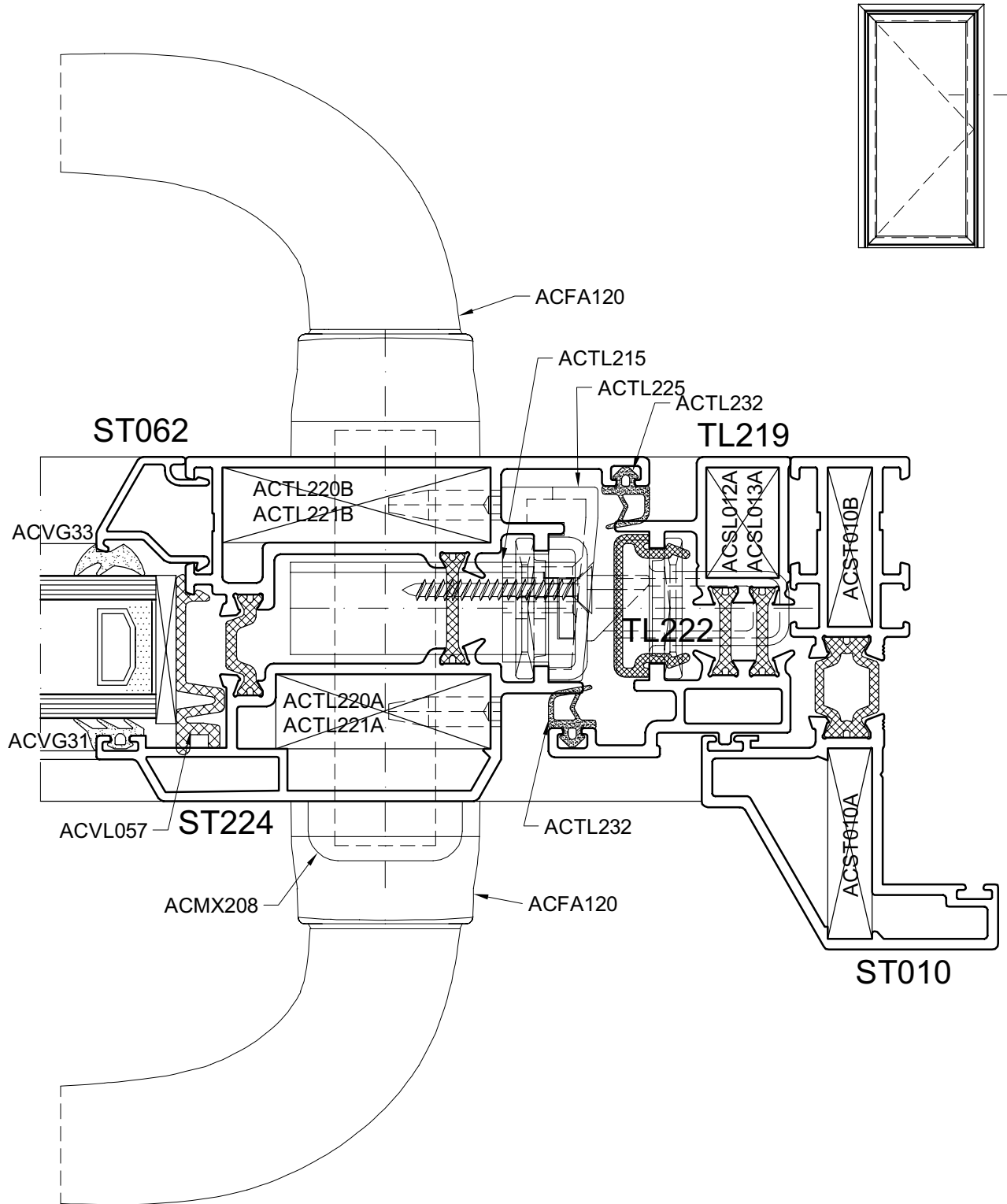

DOOR32

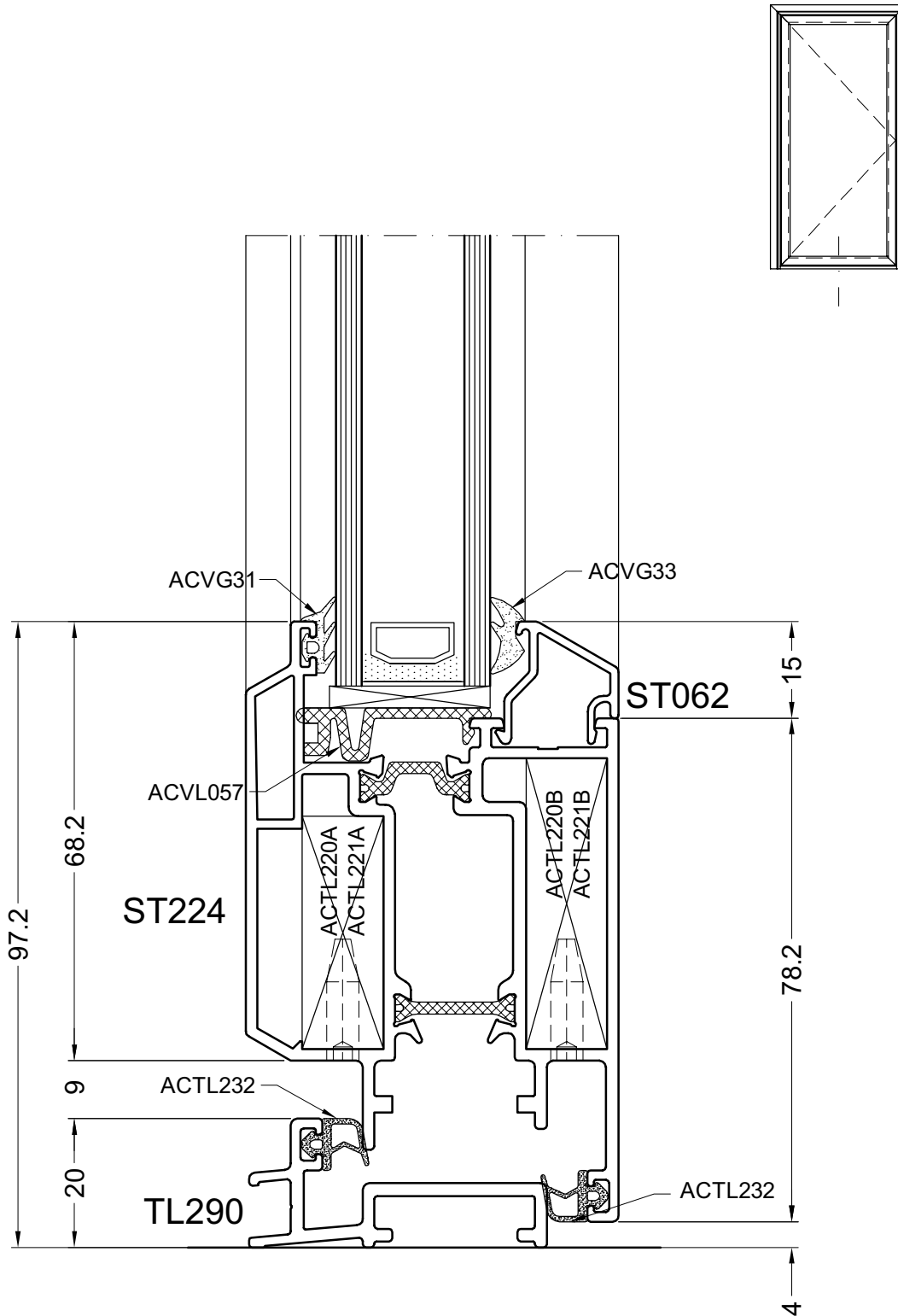

DOOR33

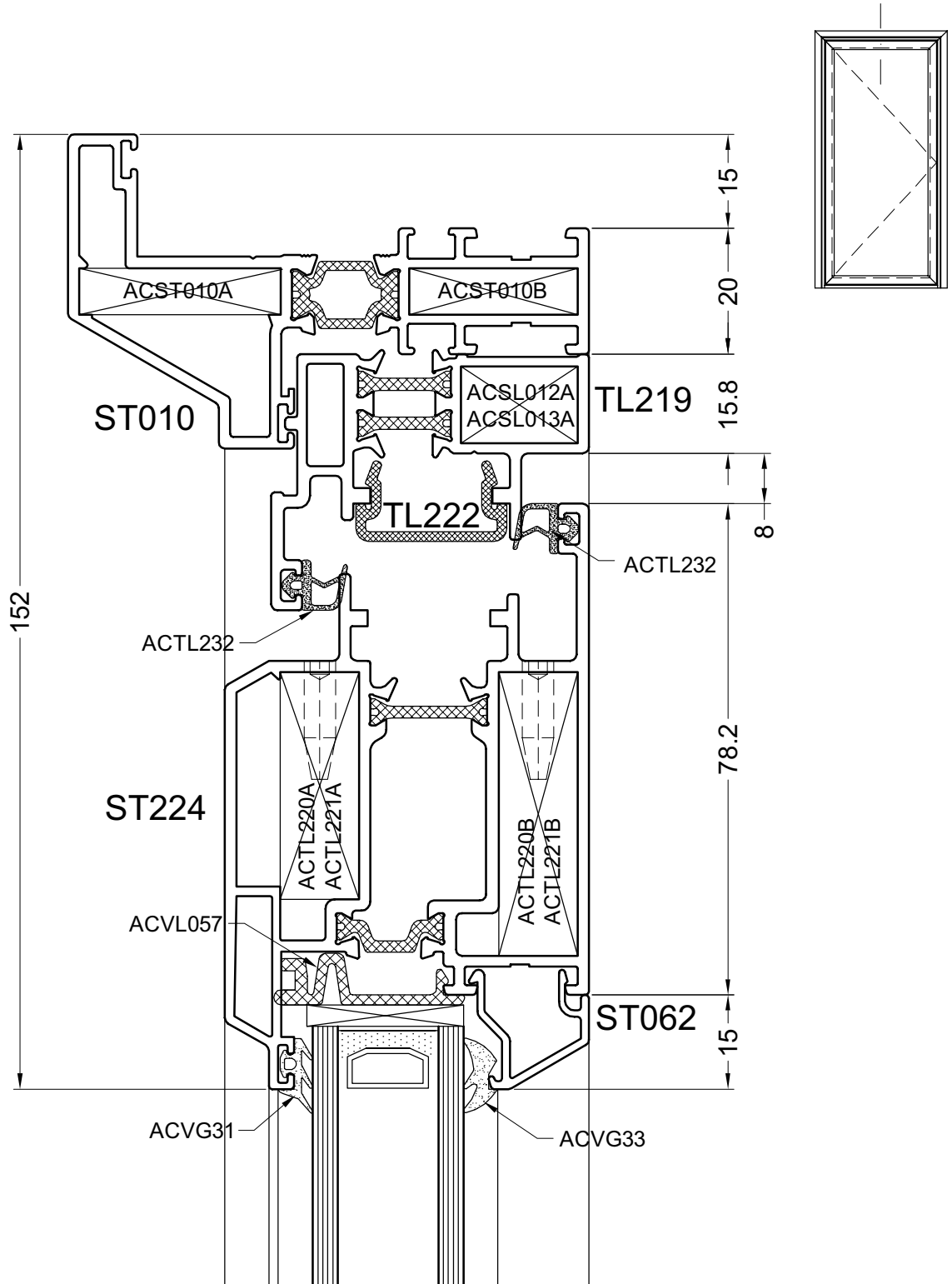

35A

DOORSNEDE - COUPE - SCHNITT - SECTION

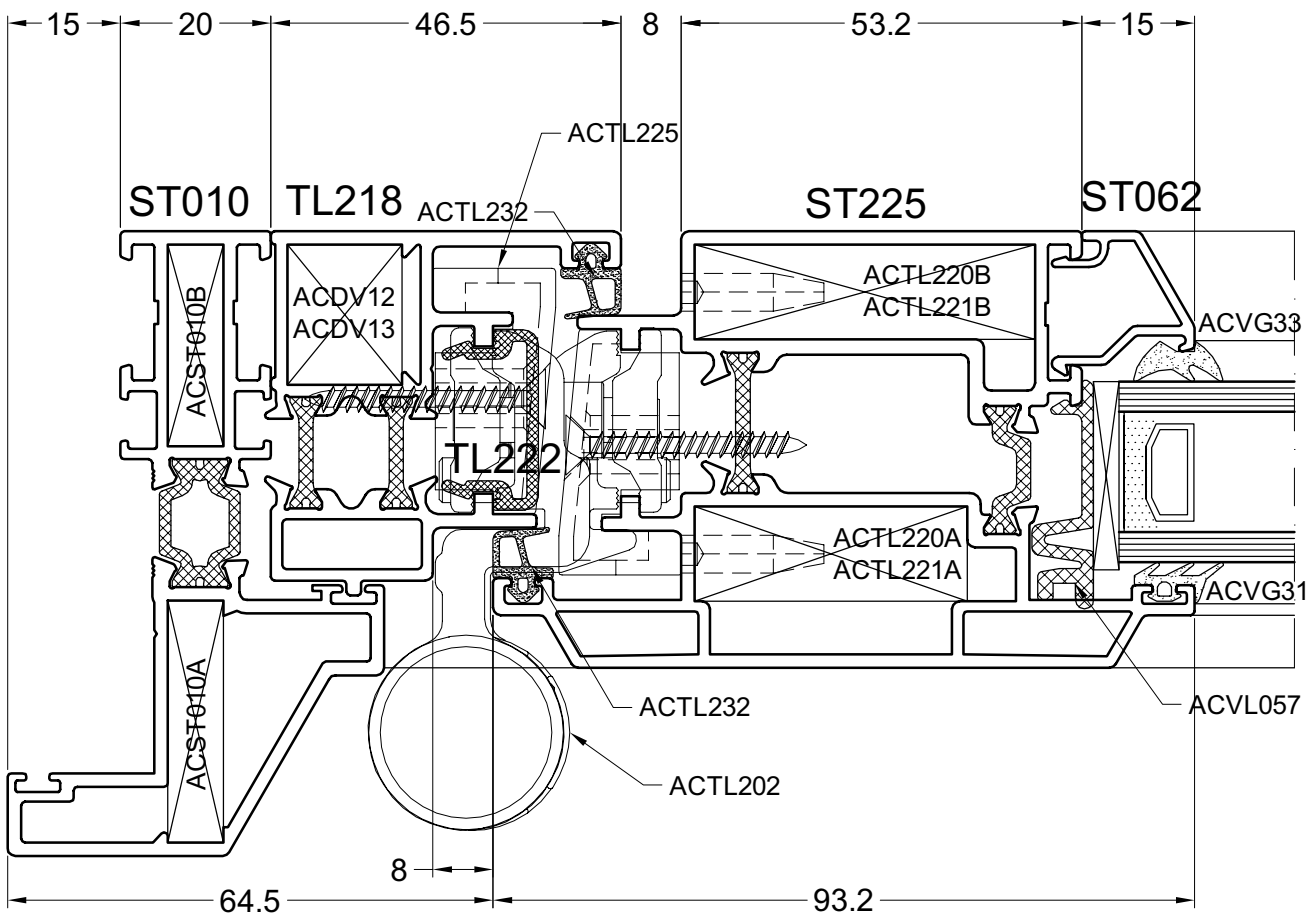
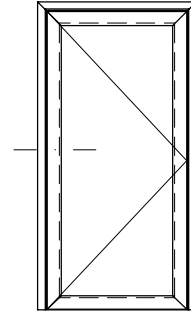

door35

35B

DOORSNEDE - COUPE - SCHNITT - SECTION

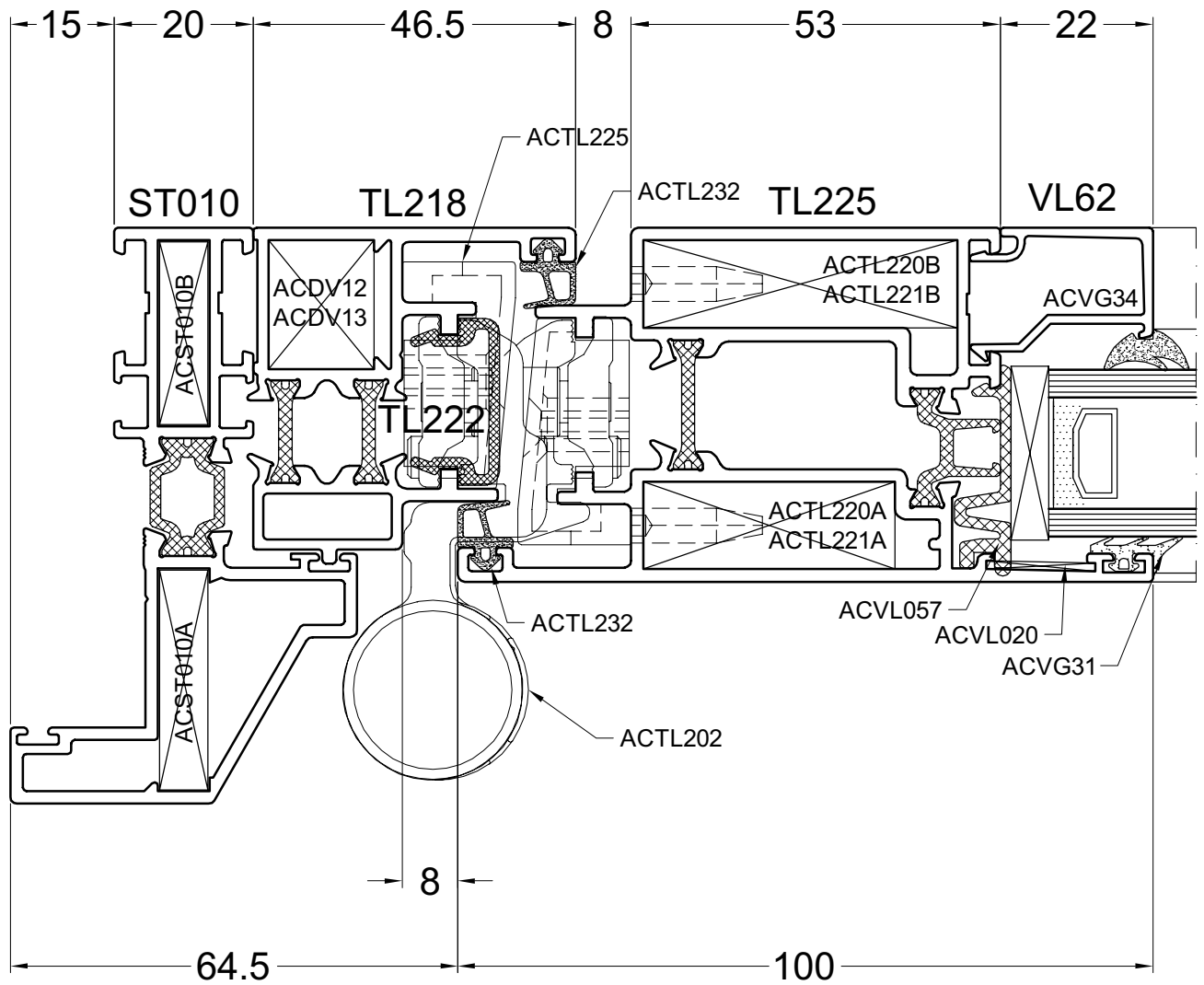
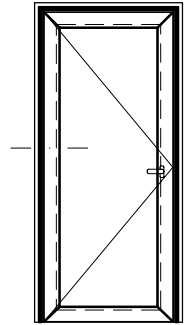

door35a

36A

DOORSNEDE - COUPE - SCHNITT - SECTION

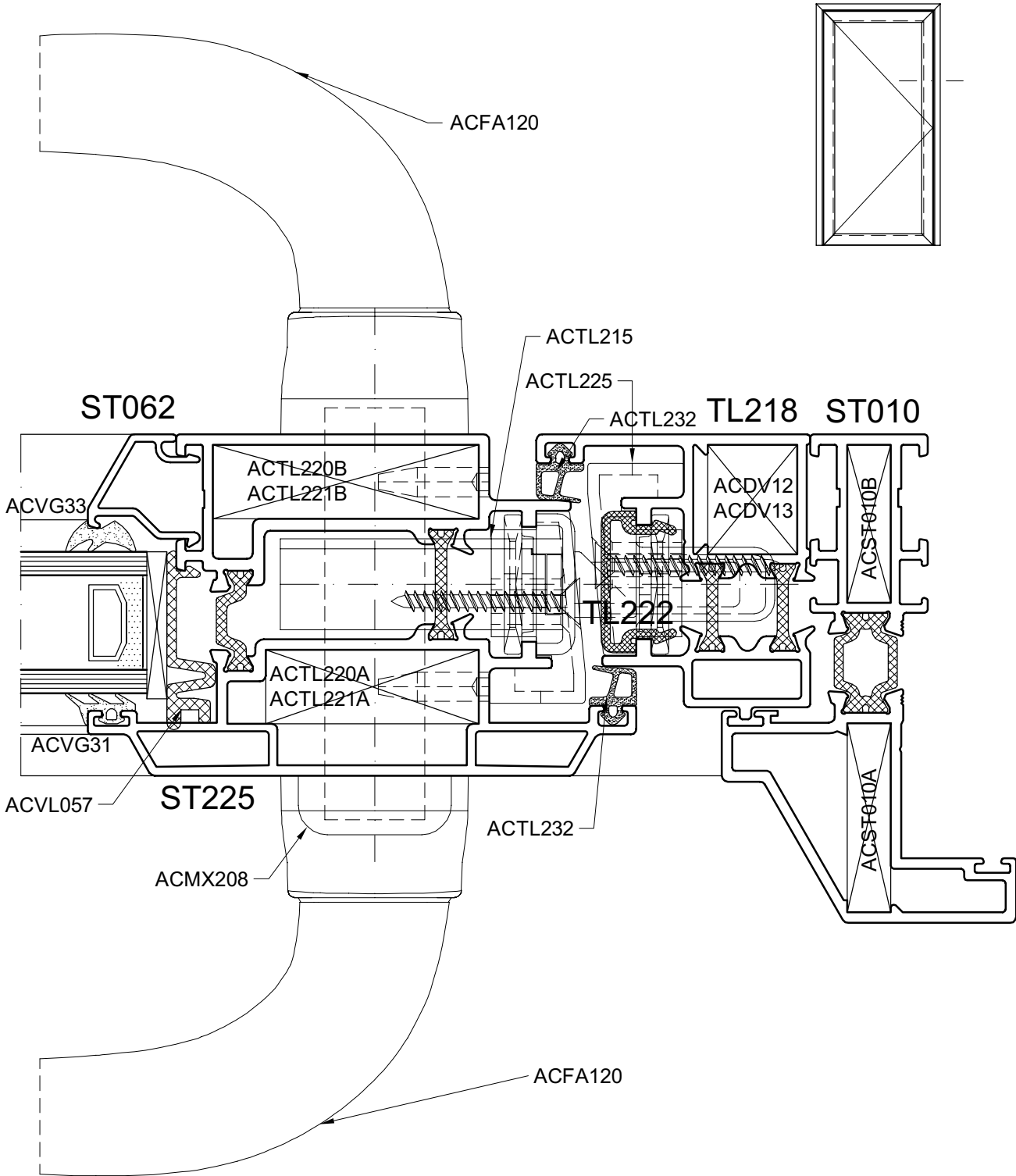

door36

36B

DOORSNEDE - COUPE - SCHNITT - SECTION

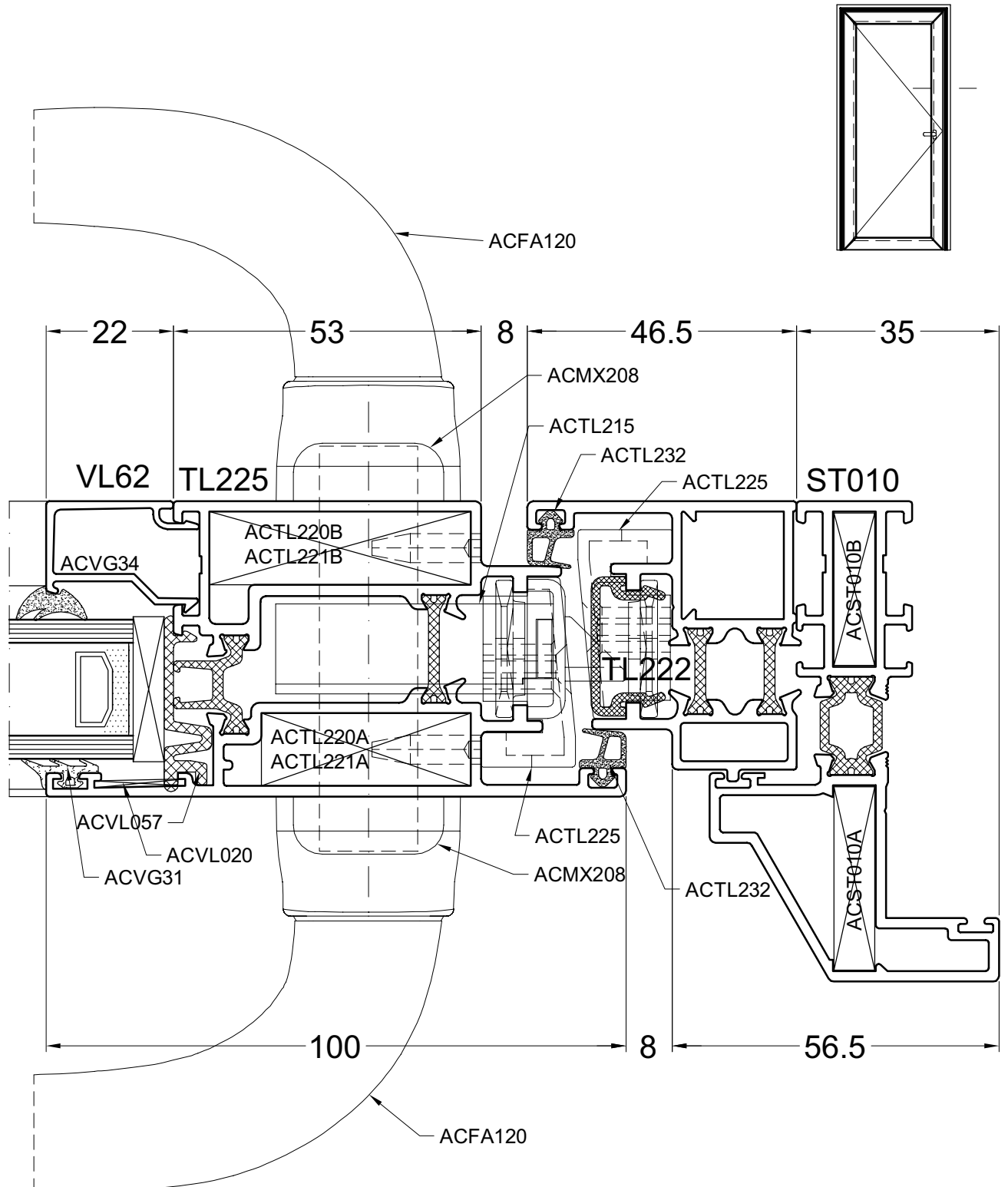

door36a

37A

DOORSNEDE - COUPE - SCHNITT - SECTION

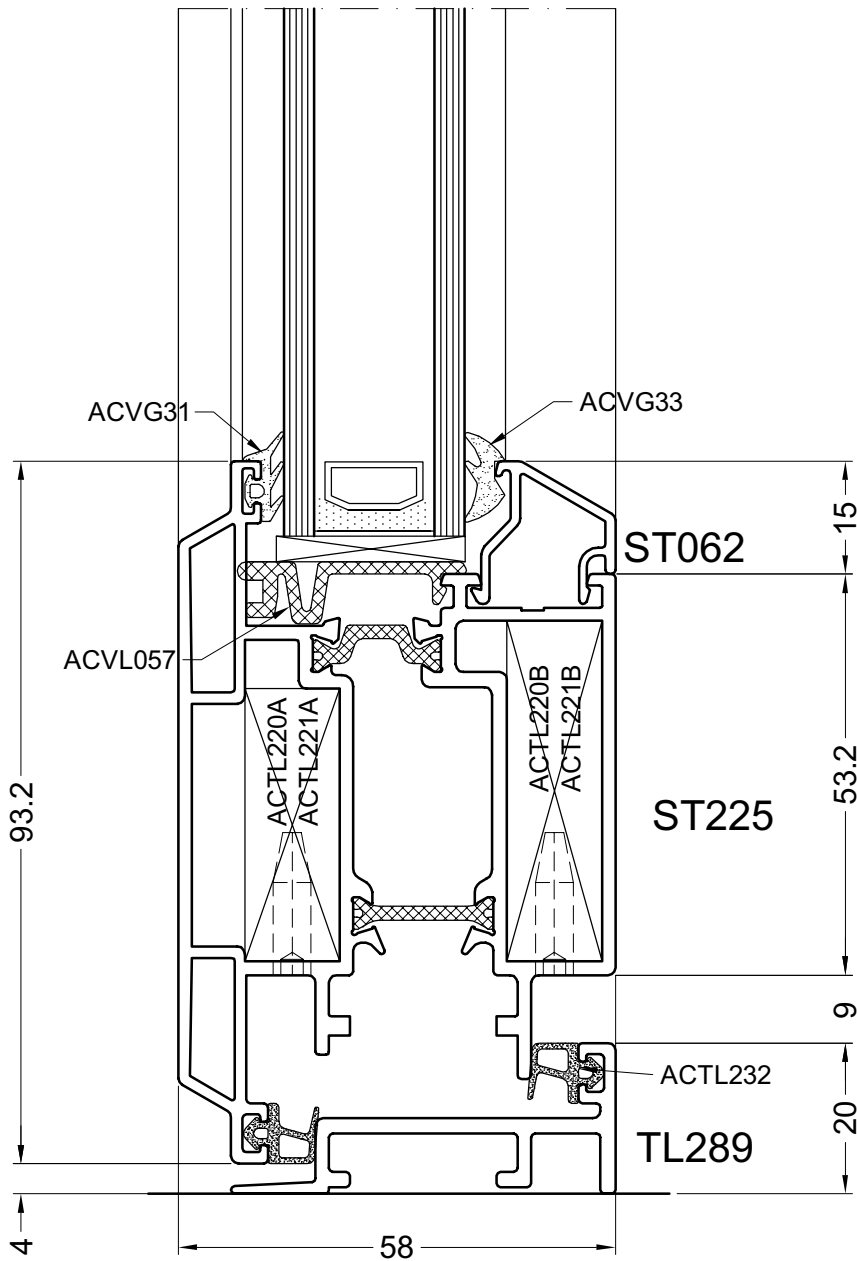
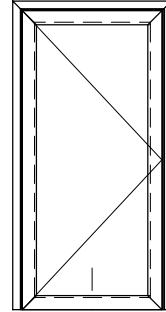

door37

37B

DOORSNEDE - COUPE - SCHNITT - SECTION

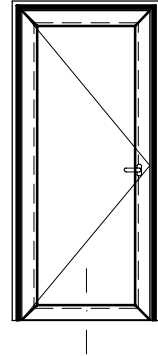
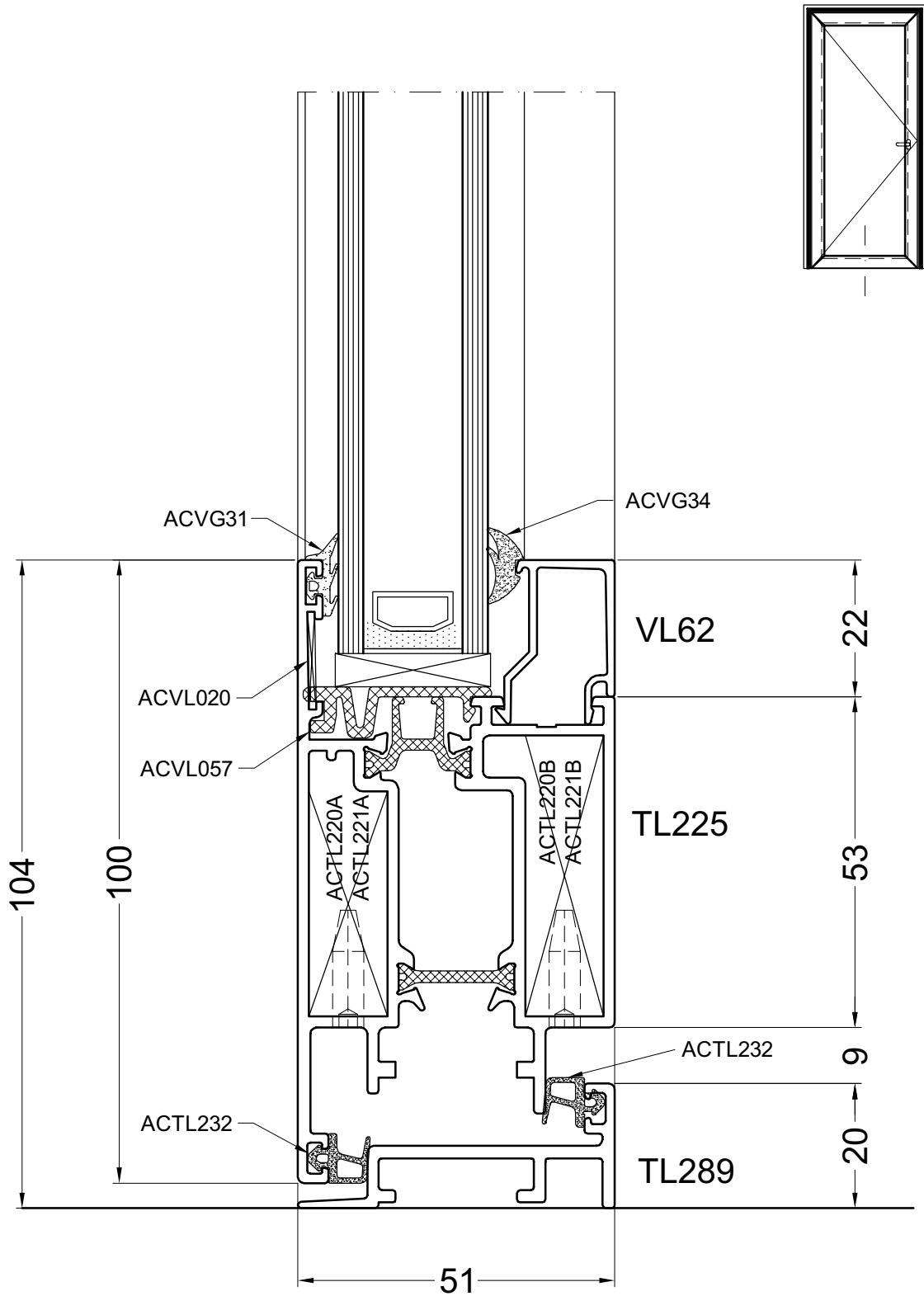

door37a

38B

DOORSNEDE - COUPE - SCHNITT - SECTION

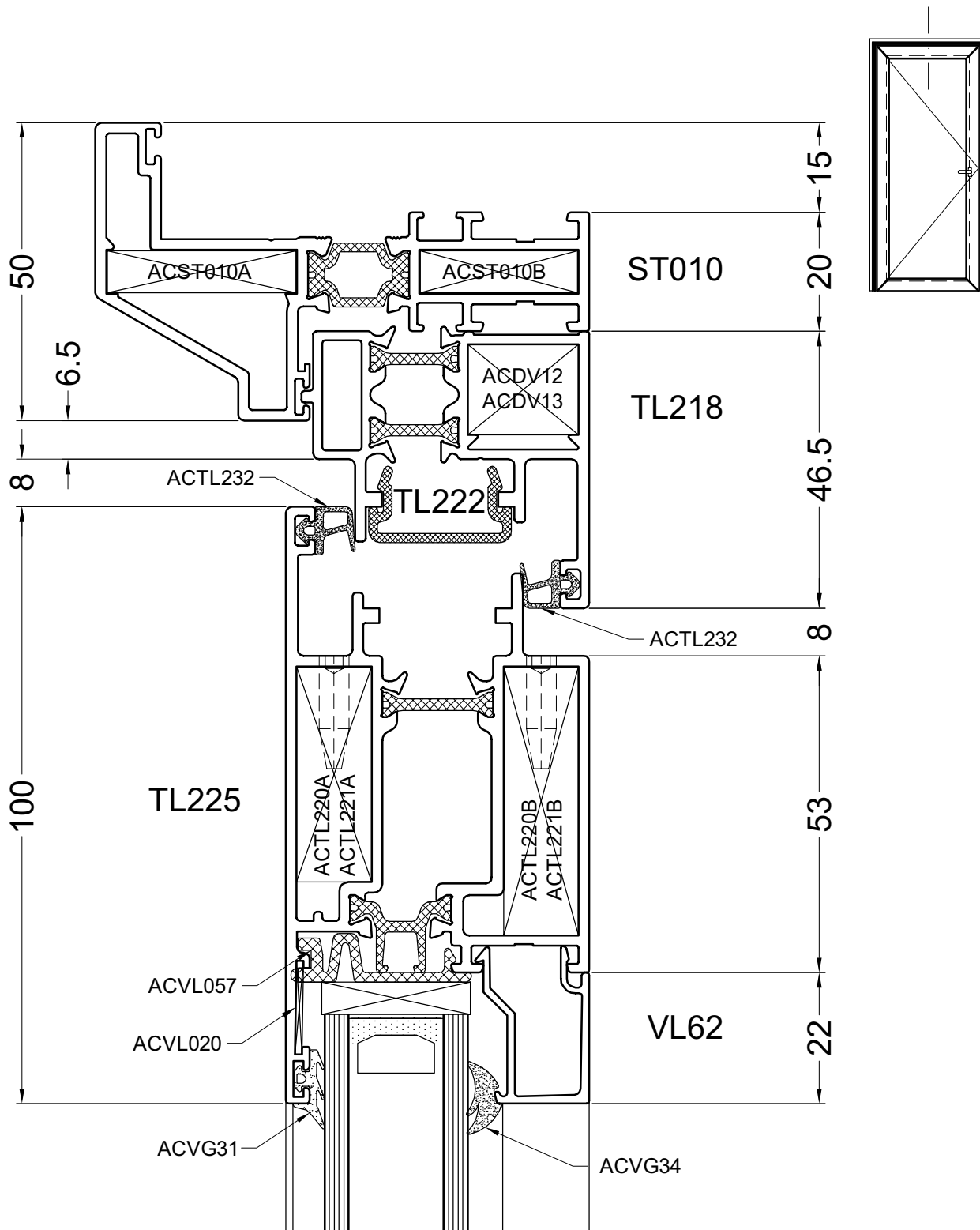

door38a



GLASMATEN
DIMENSIONS DES VITRAGES
GLASSMASSE
GLASS SIZES

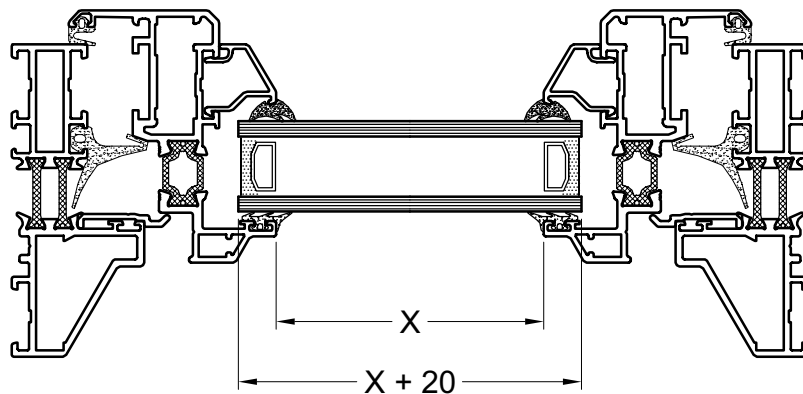
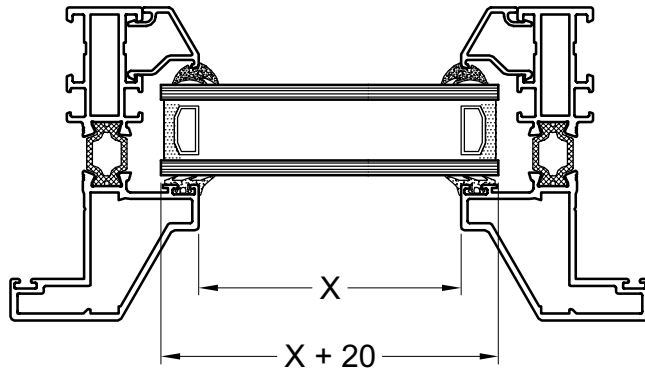

glas

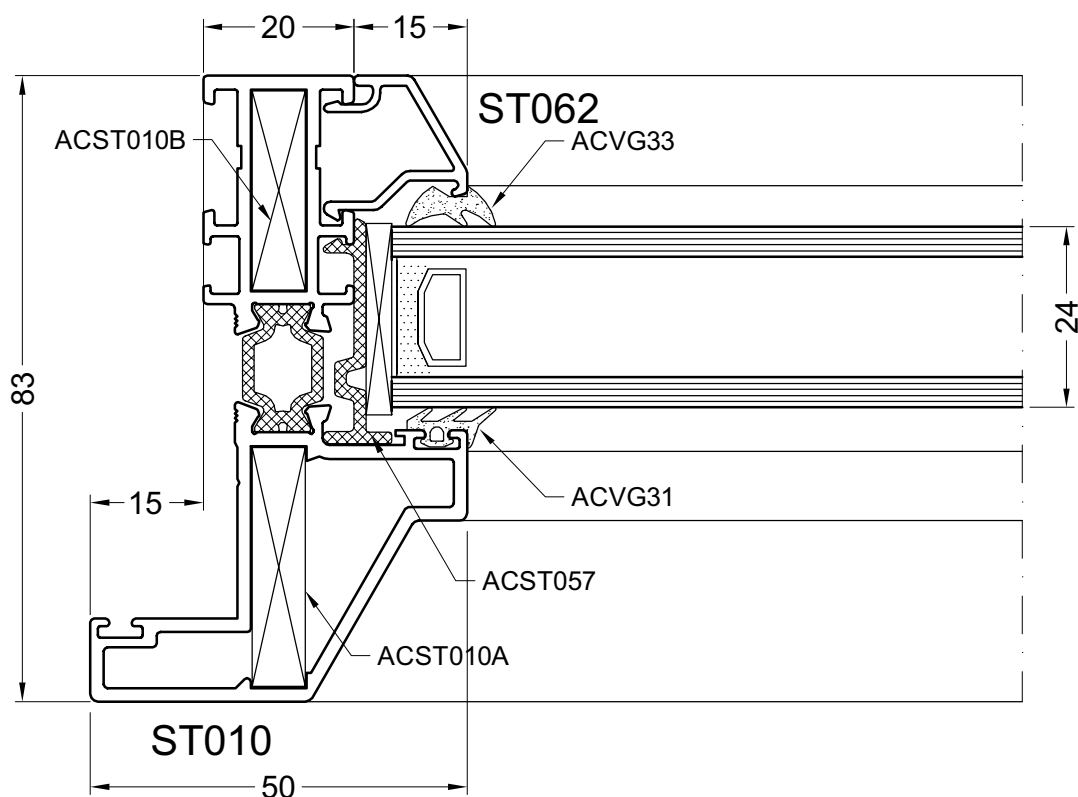

Glasdikte (X) Epaisseur de vitrage Glas dicke Glazing thickness	Rubber Buiten Joint de vitrage exterieur glasanlage dichtung glazing gasket outside	Rubber Binnen joint de vitrage glas dichtung glazing gasket	Glaslat latte a vitrage glasleitte glazing bead
22 mm	ACVG31	ACVG340	ST062 of ST162
23 mm	ACVG31	ACVG34	ST062 of ST162
24 mm	ACVG31	ACVG33	ST062 of ST162
25 mm	ACVG31	ACVG32	ST062 of ST162
26 mm	ACVG31	ACVG340	ST164
27 mm	ACVG31	ACVG34	ST164
28 mm	ACVG31	ACVG33	ST164
29 mm	ACVG31	ACVG32	ST164

Glasdikte (X) Epaisseur de vitrage Glas dicke Glazing thickness	Rubber Buiten Joint de vitrage exterieur glasanlage dichtung glazing gasket outside	Rubber Binnen joint de vitrage glas dichtung glazing gasket	Glaslat latte a vitrage glasleitte glazing bead
20 mm	ACVG131	ACVG131	ST163
22 mm	ACVG31	ACVG131	ST163
24 mm	ACVG31	ACVG31	ST163
25 mm	ACVG31	ACVG231	ST163

glaslijst

Bouwhoogte < 18m
Hauteur de bâtiment < 18m
Bauhöhe < 18m
Building height < 18m

Winddruk : 750 N/m²
Pression du vent : 750 N/m²
Winddruck : 750 N/m²
Windpressure : 750 N/m²

L (cm)	a of b (cm)																																
	20	30	40	50	60	70	80	90	100	110	120	130	140	150	160	170	180	190	200	210	220	230	240	250	260	270	280	290	300				
100	0,9	1,3	1,5	1,6																													
110	1,3	1,8	2,1	2,3																													
120	1,7	2,3	2,9	3,2	3,3																												
130	2,1	3,0	3,8	4,3	4,6																												
140	2,7	3,8	4,8	5,6	6,0	6,2																											
150	3,3	4,8	6,0	7,0	7,7	8,1																											
160	4,0	5,8	7,4	8,7	9,7	10,3	10,5																										
170	4,8	7,0	9,0	10,7	12,0	12,9	13,4																										
180	5,7	8,4	10,8	12,9	14,6	15,8	16,6	16,9																									
190	6,8	9,9	12,8	15,4	17,5	19,2	20,3	20,9																									
200	7,9	11,6	15,1	18,1	20,8	22,9	24,4	25,4	25,7																								
210	9,2	13,5	17,5	21,2	24,4	27,0	29,1	30,5	31,2																								
220	10,6	15,6	20,3	24,6	28,4	31,6	34,2	36,1	37,3	37,6																							
230	12,1	17,8	23,3	28,3	32,8	36,7	39,9	42,3	44,0	44,9																							
240	13,7	20,3	26,6	32,3	37,6	42,2	46,1	49,2	51,5	52,9	53,3																						
250	15,5	23,0	30,1	36,8	42,8	48,3	52,9	56,7	59,7	61,7	62,7																						
260	17,5	25,9	34,0	41,6	48,5	54,8	60,3	64,9	68,6	71,3	72,9	73,4																					
270	19,6	29,1	38,2	46,8	54,7	62,0	68,4	73,9	78,3	81,8	84,1	85,3																					
280	21,9	32,5	42,7	52,3	61,4	69,7	77,1	83,5	88,9	93,2	96,3	98,2	98,8																				
290	24,5	36,4	47,8	58,8	69,0	78,5	87,0	94,6	101,0	106,2	110,2	112,9	114,3																				
300	28,1	41,7	54,9	67,5	79,4	90,5	100,5	109,5	117,3	123,8	128,9	132,6	134,9	135,6																			
310	32,0	47,6	62,7	77,2	90,9	103,7	115,5	126,1	135,4	143,3	149,7	154,6	159,6																				
320	36,3	54,1	71,3	87,9	103,6	118,4	132,0	144,4	155,4	164,9	172,8	179,1	183,6	186,3	187,2																		
330	41,1	61,2	80,8	99,6	117,6	134,5	150,3	164,6	177,5	188,8	198,4	206,2	212,2	216,1	218,1																		
340	46,4	69,0	91,2	112,5	132,9	152,3	170,3	186,9	201,9	215,2	226,7	236,2	243,8	249,2	252,5	253,5																	
350	52,1	77,6	102,5	126,6	149,7	171,6	192,2	211,3	228,6	244,2	257,7	269,2	278,6	285,7	290,4	292,8																	
360	58,3	86,9	114,9	142,0	168,0	192,8	216,2	237,9	257,9	275,9	291,8	305,5	316,8	325,8	332,2	336,1	337,4																
370	65,1	97,0	128,3	158,7	187,9	215,9	242,3	267,0	289,7	310,5	329,0	345,1	358,7	369,8	378,2	383,8	386,6																
380	72,4	108,0	142,9	176,8	209,6	240,9	270,6	298,5	324,4	348,2	369,5	388,3	404,5	417,9	428,5	436,1	440,6	442,2															
390	80,3	119,9	158,7	196,4	233,0	268,0	301,4	332,8	362,1	389,1	413,6	435,4	454,4	470,4	483,4	493,2	499,8	503,1															
400	88,9	132,7	175,7	217,7	258,3	297,4	334,7	369,9	402,9	433,4	461,3	486,4	508,5	527,4	543,1	555,4	564,3	569,6	571,4														
410	98,2	146,6	194,1	240,6	285,6	329,0	370,6	410,0	447,0	481,4	513,1	541,7	567,2	589,3	608,0	623,1	634,5	642,2	646,0														
420	108,1	161,5	213,9	265,2	315,0	363,2	409,3	453,2	494,5	533,2	568,9	601,4	630,6	656,3	678,3	696,5	710,8	721,1	727,2	729,3													
430	118,8	177,5	235,2	291,7	346,7	399,8	450,9	499,6	545,7	588,9	629,1	665,8	699,1	728,6	754,3	775,9	793,4	806,5	815,4	819,8													
440	130,3	194,6	258,0	320,1	380,6	439,2	495,6	549,5	600,7	648,9	693,8	735,2	772,8	806,6	836,2	861,6	882,6	899,0	910,8	917,9	920,3												
450	142,6	213,0	282,4	350,5	416,9	481,4	543,5	603,1	659,7	713,2	763,3	809,6	852,1	890,4	924,4	953,9	978,7	998,8	1013,9	1024,0	1029,1												
460	155,7	232,7	308,6	383,1	455,8	526,5	594,8	660,3	722,9	782,1	837,7	889,5	937,1	980,4	1019,2	1053,2	1082,2	1106,2	1125,0	1138,5	1146,6	1149,3											
470	169,7	253,6	336,4	417,8	497,3	574,7	649,6	721,6	790,4	855,8	917,4	975,0	1028,2	1076,9	1120,8	1159,6	1193,3	1221,7	1244,5	1261,8	1273,3	1279,1											
480	184,6	276,0	366,2	454,9	541,6	626,1	708,0	786,9	862,5	934,5	1002,5	1066,3	1125,6	1180,1	1229,5	1273,7	1312,5	1345,6	1372,9	1394,2	1409,6	1418,8	1421,9										
490	200,5	299,8	397,8	494,3	588,8	680,9	770,3	856,6	939,4	1018,5	1093,4	1163,9	1229,6	1290,3	1345,8	1395,7	1439,9	1478,2	1510,4	1536,3	1555,8	1568,9	1575,5										
500	217,4	325,1	431,5	536,3	639,0	739,2	836,6	930,7	1021,3	1107,9	1190,1	1267,8	1340,5	1407,9	1469,9	1526,0	1576,1	1620,0	1657,5	1688,4	1712,6	1729,9	1740,4	1743,9									
510	235,4	352,0	467,3	580,8	692,3	801,1	907,0	1009,5	1108,3	1202,9	1293,1	1378,4	1458,5	1533,2	1602,1	1664,9	1721,4	1771,4	1814,6	1851,0	1880,2	1902,3	1917,0	1924,4									
520	254,4	380,5	505,2	628,1	748,8	866,8	981,8	1093,2	1200,7	1303,9	1402,5	1495,9	1584,0	1666,4	1742,7	1812,8	1876,2	1932,7	1982,2	2024,5	2059,3	2086,5	2106,0	2117,8	2121,7								
530	274,6	410,7	545,4	678,2	808,8	936,5	1061,0	1181,9	1298,7	1411,1	1518,5	1620,7	1717,3	1807,9	1892,3	1970,0	2040,8	2104,4	2160,7	2209,3	2250,1	2283,0	2307,8	2324,3	2332,6								
540	295,9	442,7	587,9	731,3	872,2	1010,3	1145,0	1275,9	1402,6	1524,6	1641,6	1753,1	1858,7	1958,1	2051,0	2136,9	2215,7	2286,9	2350,5	2406,0	2453,4	2492,4	2522,9	2544,8	2557,9	2562,3							
550	318,5	476,4	632,9	787,4	939,3	1088,3	1233,7	1375,3	1512,5	1644,8	1771,8	1893,2	2008,4	2117,2	2219,2	2313,9	2401,2	2480,6	2552,0	2615,0	2669,4	2715,1	2751,9	2779,6	2798,1	2807,3							
560	342,3	512,1	680,4	846,6	1010,2	1170,7	1327,6	1480,4	1628,6	1771,8	1909,6	2041,4	2166,9	2285,7	2397,3	2501,5	2597,8	2686,0	2765,7	2836,7	2898,8	2951,7	2995,3	3029,3	3053,7	3068,4	3073,3						
570	367,4	549,8	730,5	909,1	1085,0	1257,7	1426,6	1591,3	1751,3	1906,0	2055,1	2198,0	2334,4	2463,8	2585,7	2699,9	2805,9	2903,4	2992,1	3071,8	3142,1	3202,7	3253,7	3294,6	3325,4	3346,0	3356,4						
580	393,9	589,5	783,4	975,0	1163,9	1349,4	1531,1	1708,3	1880,7	2047,7	2208,7	2363,4	2511,3	2651,9	2784,8	2909,6	3025,9	3133,4	3231,7	3320,6	3399,6	3468,7	3527,6	3576,0	3613,8	3641,0	3657,3	3662,7					
590	421,8	631,3	839,0	1044,4	1247,0	1446,0	1641,1	1831,6	2017,1	2196,9	2370,7	2537,8	2697,8	2850,3	2994,8	3130,9	3258,2	3376,3	3484,9	3583,6													

Bouwhoogte < 50m
Hauteur de bâtiment < 50m
Bauhöhe < 50m
Building height < 50m

Winddruk : **1000 N/m²**
Pression du vent : **1000 N/m²**
Winddruck : **1000 N/m²**
Windpressure : **1000 N/m²**

L (cm)	a of b (cm)																														
	20	30	40	50	60	70	80	90	100	110	120	130	140	150	160	170	180	190	200	210	220	230	240	250	260	270	280	290	300		
100	1,3	1,7	2,0	2,1																											
110	1,7	2,4	2,9	3,1																											
120	2,2	3,1	3,8	4,3	4,4																										
130	2,8	4,0	5,0	5,7	6,1																										
140	3,6	5,1	6,4	7,4	8,0	8,2																									
150	4,4	6,4	8,0	9,4	10,3	10,8																									
160	5,3	7,8	9,9	11,7	13,0	13,8	14,0																								
170	6,4	9,4	12,0	14,3	16,0	17,2	17,8																								
180	7,7	11,2	14,4	17,2	19,5	21,1	22,1	22,5																							
190	9,0	13,2	17,1	20,5	23,3	25,5	27,1	27,8																							
200	10,5	15,5	20,1	24,2	27,7	30,5	32,6	33,9	34,3																						
210	12,2	18,0	23,4	28,3	32,5	36,0	38,8	40,6	41,6																						
220	14,1	20,8	27,0	32,8	37,8	42,2	45,6	48,1	49,7	50,2																					
230	16,1	23,8	31,0	37,7	43,7	48,9	53,2	56,5	58,7	59,8																					
240	18,3	27,1	35,4	43,1	50,1	56,3	61,5	65,6	68,6	70,5	71,1																				
250	20,7	30,7	40,2	49,0	57,1	64,3	70,6	75,7	79,6	82,2	83,5																				
260	23,3	34,6	45,3	55,4	64,7	73,1	80,4	86,6	91,5	95,0	97,2	97,9																			
270	26,1	38,8	50,9	62,3	73,0	82,6	91,2	98,5	104,5	109,0	112,1	113,7																			
280	29,2	43,3	56,9	69,8	81,8	92,9	102,7	111,3	118,5	124,2	128,4	130,9	131,7																		
290	32,6	48,5	63,8	78,4	92,0	104,6	116,0	126,1	134,7	141,7	147,0	150,6	152,4																		
300	37,4	55,6	73,2	90,0	105,9	120,6	134,0	146,0	156,3	165,0	171,9	176,8	179,8	180,8																	
310	42,7	63,5	83,6	102,9	121,2	138,3	154,0	168,1	180,5	191,0	199,6	206,1	210,5	212,7																	
320	48,5	72,1	95,1	117,2	138,2	157,9	176,0	192,5	207,2	219,9	230,4	238,8	244,8	248,4	249,7																
330	54,8	81,6	107,7	132,9	156,8	179,4	200,3	219,5	236,7	251,8	264,6	275,0	282,9	288,2	290,9																
340	61,8	92,1	121,6	150,0	177,3	203,0	227,0	249,2	269,2	286,9	302,3	315,0	325,0	332,2	336,6	338,1															
350	69,4	103,4	136,7	168,8	199,6	228,9	256,3	281,7	304,8	325,5	343,7	359,0	371,4	380,9	387,2	390,4															
360	77,7	115,9	153,1	189,3	224,0	257,1	288,2	317,2	343,8	367,8	389,0	407,3	422,5	434,4	442,0	448,2	449,9														
370	86,7	129,4	171,1	211,6	250,6	287,8	323,0	355,9	386,3	414,0	438,6	460,1	478,3	493,1	504,2	511,7	515,5														
380	96,5	144,0	190,5	235,7	279,4	321,2	360,8	398,1	432,6	464,2	492,7	517,8	539,4	557,2	571,3	581,4	587,5	589,5													
390	107,1	159,8	211,6	261,9	310,6	357,4	401,8	443,7	482,8	518,8	551,4	580,5	605,8	627,2	644,5	657,6	666,4	670,8													
400	118,6	177,0	234,3	290,2	344,4	396,5	446,2	493,2	537,2	577,9	615,1	648,6	678,0	703,3	724,2	740,6	752,4	759,5	761,9												
410	130,9	195,4	258,8	320,7	380,8	438,7	494,1	546,6	596,0	641,9	684,1	722,3	756,2	785,8	810,7	830,8	846,1	856,3	861,4												
420	144,2	215,3	285,2	353,6	420,1	484,2	545,7	604,2	659,4	710,9	758,5	801,9	840,9	875,1	904,4	928,7	947,7	961,4	969,7	972,4											
430	158,4	236,6	313,6	388,9	462,2	533,1	601,2	666,2	727,6	785,3	838,7	887,8	932,1	971,5	1005,7	1034,5	1057,8	1075,4	1087,2	1093,1											
440	173,7	259,5	344,0	426,8	507,5	585,6	660,8	732,7	801,0	865,2	925,0	980,2	1030,5	1075,5	1115,0	1148,8	1176,8	1198,7	1214,4	1223,9	1227,1										
450	190,1	284,0	376,6	467,4	555,9	641,8	724,7	804,1	879,6	950,9	1017,7	1079,5	1136,1	1187,2	1232,6	1271,9	1305,0	1331,7	1351,9	1365,4	1372,1										
460	207,6	310,2	411,4	510,7	607,8	702,0	793,0	880,5	963,8	1042,8	1117,0	1186,0	1249,5	1307,2	1358,9	1404,2	1443,0	1474,9	1500,0	1518,0	1528,8	1532,5									
470	226,3	338,2	448,6	557,1	663,1	766,3	866,1	962,1	1053,9	1141,1	1223,2	1300,0	1370,9	1435,8	1494,4	1546,2	1591,1	1628,9	1659,4	1682,4	1697,8	1705,5									
480	246,2	368,0	488,2	606,5	722,2	834,9	944,0	1049,3	1150,1	1246,0	1336,7	1421,8	1500,8	1573,4	1639,4	1698,3	1749,9	1794,1	1830,5	1859,0	1879,4	1891,8	1895,9								
490	267,4	399,7	530,5	659,1	785,1	907,9	1027,1	1142,1	1252,6	1358,0	1457,8	1551,8	1639,5	1720,4	1794,4	1861,0	1919,9	1970,8	2013,8	2048,4	2074,5	2091,9	2100,7								
500	289,9	433,5	575,4	715,0	852,0	985,6	1115,4	1241,0	1361,7	1477,1	1586,9	1690,4	1787,3	1877,2	1959,8	2034,7	2101,5	2160,0	2210,0	2251,2	2283,4	2306,6	2320,5	2325,1							
510	313,8	469,3	623,0	774,5	923,0	1068,2	1209,4	1346,0	1477,7	1603,9	1724,1	1837,8	1944,7	2044,2	2136,1	2219,8	2295,2	2361,9	2419,5	2468,0	2507,0	2536,4	2556,1	2565,9							
520	339,2	507,3	673,6	837,5	998,4	1155,8	1309,0	1457,6	1601,0	1738,6	1869,9	1994,6	2112,1	2221,9	2323,7	2417,0	2501,6	2577,0	2643,0	2699,3	2745,7	2782,0	2808,0	2823,7	2828,9						
530	366,1	547,6	727,2	904,3	1078,3	1248,7	1414,7	1575,9	1731,6	1881,4	2024,7	2161,0	2289,8	2410,6	2523,0	2626,6	2721,0	2805,9	2880,9	2945,8	3000,2	3044,0	3077,0	3099,1	3110,2						
540	394,6	590,2	783,9	975,0	1162,9	1347,0	1526,6	1701,2	1870,1	2032,8	2188,8	2337,4	2478,3	2610,8	2734,6	2849,2	2954,2	3049,2	3133,9	3208,0	3271,2	3323,2	3363,8	3393,0	3410,6	3416,4					
550	424,6	635,3	843,9	1049,8	1252,4	1451,0	1645,0	1833,7	2016,6	2193,0	2362,4	2524,2	2677,9	2823,0	2958,9	3085,2	3201,6	3307,5	3402,6	3486,6	3559,2	3620,1	3669,2	3706,1	3730,8	3743,1					
560	456,4	682,9	907,2	1128,8	1346,9	1560,9	1770,1	1973,8	2171,5	2362,4	2546,1	2721,9	2889,2	3047,6	3196,4	3335,3	3463,7	3581,3	3687,6	3782,3	3865,1	3935,6	3993,7	4039,1	4071,6	4091,2	4097,7				
570	489,9	733,1	974,1	1212,2	1446,7	1676,9	1902,1	2121,7	2335,0	2541,4	2740,2	2930,7	3112,5	3285,0	3447,6	3599,8	3741,2	3871,2	3989,5	4095,7	4189,4	4270,3	4338,2	4392,8	4433,9	4461,4	4475,2				
580	525,3	786,0	1044,5	1300,0	1551,8	1799,2	2041,4	2277,8	2507,6	2730,2	2945,0	3151,2	3348,4	3535,8	3713,0	3879,4	4034,5	4177,8	4308,9	4427,4	4532,9	4625,0	4703,4	4768,0	4818,5	4854,6	4876,4	4883,6			
590	562,5	841,7	1118,7	1392,6	1662,6	1928,1	2188,2	2442,2	2689,5	2929,2	3160,9	3383,7	3597,1	3800,4	3993,1	4174,6	4344,3	4501,8	4646,5	4778,1	4896,2	5000,3	5090,2	5165,5							

Bouwhoogte > 50m
Hauteur de bâtiment > 50m
Bauhöhe > 50m
Building height > 50m

Winddruk : **1750 N/m²**
Pression du vent : **1750 N/m²**
Winddruck : **1750 N/m²**
Windpressure : **1750 N/m²**

L (cm)	a of b (cm)																																
	20	30	40	50	60	70	80	90	100	110	120	130	140	150	160	170	180	190	200	210	220	230	240	250	260	270	280	290	300				
100	2,2	3,0	3,6	3,8																													
110	3,0	4,1	5,0	5,4																													
120	3,9	5,5	6,7	7,5	7,8																												
130	5,0	7,1	8,8	10,0	10,6																												
140	6,2	9,0	11,2	13,0	14,0	14,4																											
150	7,7	11,1	14,1	16,4	18,0	18,9																											
160	9,4	13,6	17,3	20,4	22,7	24,1	24,6																										
170	11,3	16,4	21,0	24,9	28,0	30,1	31,2																										
180	13,4	19,6	25,2	30,1	34,0	37,0	38,8	39,4																									
190	15,8	23,2	29,9	35,9	40,8	44,7	47,4	48,7																									
200	18,5	27,1	35,1	42,3	48,4	53,4	57,0	59,3	60,0																								
210	21,4	31,5	40,9	49,5	56,9	63,1	67,8	71,1	72,7																								
220	24,6	36,3	47,3	57,3	66,2	73,8	79,8	84,2	86,9	87,8																							
230	28,2	41,6	54,3	66,0	76,5	85,6	93,1	98,8	102,7	104,7																							
240	32,0	47,4	62,0	75,5	87,7	98,5	107,6	114,8	120,1	123,3	124,4																						
250	36,2	53,7	70,3	85,8	100,0	112,6	123,5	132,4	139,2	143,9	146,2																						
260	40,8	60,5	79,3	97,0	113,3	127,9	140,8	151,5	160,1	166,3	170,1	171,4																					
270	45,7	67,8	89,1	109,1	127,7	144,6	159,5	172,3	182,8	190,8	196,2	198,9																					
280	51,0	75,8	99,6	122,1	143,2	162,5	179,8	194,8	207,4	217,4	224,6	229,0	230,5																				
290	57,1	84,9	111,6	137,1	161,1	183,1	203,1	220,6	235,6	247,9	257,2	263,5	266,7																				
300	65,5	97,3	128,1	157,6	185,3	211,1	234,5	255,5	273,6	288,8	300,7	309,4	314,7	316,4																			
310	74,7	111,1	146,3	180,2	212,2	242,0	269,4	294,1	315,8	334,3	349,3	360,7	368,4	372,3																			
320	84,8	126,2	166,4	205,1	241,8	276,2	308,1	336,9	362,6	384,8	403,3	417,9	428,4	434,8	436,9																		
330	95,9	142,9	188,5	232,5	274,4	313,9	350,6	384,2	414,3	440,6	463,0	481,2	495,0	504,3	509,0																		
340	108,2	161,1	212,7	262,6	310,2	355,3	397,3	436,1	471,1	502,2	528,9	551,2	568,8	581,4	589,1	591,6																	
350	121,5	181,0	239,2	295,4	349,3	400,5	448,5	492,9	533,5	569,7	601,4	628,2	650,0	666,5	677,6	683,2																	
360	136,0	202,8	268,0	331,3	392,0	449,9	504,4	555,1	601,7	643,7	680,8	712,8	739,3	760,2	775,2	784,3	787,3																
370	151,8	226,4	299,4	370,2	438,5	503,7	565,3	622,9	676,1	724,4	767,6	805,2	837,1	862,9	882,4	895,5	902,1																
380	168,9	252,0	333,4	412,6	489,0	562,1	631,5	696,6	757,0	812,4	862,2	906,1	943,9	975,2	999,8	1017,5	1028,1	1031,7															
390	187,5	279,7	370,2	458,4	543,6	625,4	703,2	776,6	844,9	907,9	965,0	1015,9	1060,2	1097,6	1127,9	1150,8	1166,1	1173,8															
400	207,5	309,7	410,0	507,9	602,7	693,9	780,9	863,1	940,1	1011,4	1076,5	1135,0	1186,5	1230,7	1267,3	1296,0	1316,7	1329,2	1333,3														
410	229,1	342,0	452,9	561,3	666,4	767,8	864,7	956,6	1043,0	1123,3	1197,1	1264,0	1323,4	1375,1	1418,7	1454,0	1480,6	1498,5	1507,4														
420	252,3	376,8	499,1	618,8	735,1	847,4	955,0	1057,4	1153,9	1244,1	1327,4	1403,4	1471,5	1531,4	1582,8	1625,2	1658,5	1682,5	1696,9	1701,7													
430	277,3	414,1	548,8	680,6	808,9	932,9	1052,1	1165,8	1273,3	1374,2	1467,8	1553,6	1631,2	1700,2	1760,0	1810,5	1851,2	1881,9	1902,5	1912,9													
440	304,0	454,1	602,0	746,9	888,0	1024,8	1156,4	1282,2	1401,7	1514,0	1618,8	1715,4	1803,3	1882,0	1951,2	2010,4	2059,3	2097,7	2125,2	2141,8	2147,3												
450	332,7	497,0	659,0	817,9	972,9	1123,2	1268,2	1407,1	1539,3	1664,1	1780,9	1889,1	1988,2	2077,7	2157,0	2225,8	2283,7	2330,5	2365,7	2389,4	2401,2												
460	363,3	542,9	720,0	893,8	1063,6	1228,5	1387,8	1540,8	1686,7	1824,9	1954,7	2075,5	2186,6	2287,7	2378,1	2457,4	2525,2	2581,2	2625,0	2656,5	2675,5	2681,8											
470	396,0	591,8	785,0	974,9	1160,5	1341,0	1515,7	1683,7	1844,3	1996,9	2140,6	2274,9	2399,1	2512,7	2615,1	2705,8	2784,5	2850,6	2903,9	2944,1	2971,1	2984,6											
480	430,8	644,0	854,4	1061,3	1263,8	1461,0	1652,1	1836,2	2012,6	2180,5	2339,3	2488,1	2626,4	2753,5	2868,9	2972,0	3062,4	3139,6	3203,3	3253,2	3289,0	3310,6	3317,8										
490	467,9	699,5	928,3	1153,4	1373,9	1588,8	1797,4	1998,7	2192,0	2376,4	2551,2	2715,7	2869,1	3010,8	3140,2	3256,7	3359,8	3449,2	3524,2	3584,7	3630,3	3660,8	3676,1										
500	507,3	758,6	1006,9	1251,3	1490,9	1724,8	1952,0	2171,7	2383,0	2585,0	2777,0	2958,2	3127,8	3285,2	3429,7	3560,7	3677,6	3780,1	3867,5	3939,6	3996,0	4036,5	4060,9	4069,0									
510	549,2	821,3	1090,3	1355,3	1615,3	1869,3	2116,4	2355,6	2586,0	2806,9	3017,2	3216,2	3403,2	3577,4	3738,1	3884,7	4016,6	4133,3	4234,2	4318,9	4387,2	4438,7	4473,1	4490,4									
520	593,6	887,8	1178,8	1465,6	1747,2	2022,6	2290,8	2550,8	2801,7	3042,5	3272,4	3490,5	3696,1	3888,3	4066,4	4229,8	4377,7	4509,7	4625,2	4723,8	4804,9	4868,5	4914,0	4941,4	4950,6								
530	640,7	958,3	1272,6	1582,5	1887,1	2185,2	2475,7	2757,8	3030,4	3292,5	3543,2	3781,7	4007,1	4218,5	4415,3	4596,6	4761,8	4910,3	5041,6	5155,1	5250,3	5327,0	5384,8	5423,5	5442,8								
540	690,5	1032,9	1371,8	1706,3	2035,1	2357,3	2671,6	2977,1	3272,7	3557,4	3830,3	4090,5	4336,9	4568,9	4785,6	4986,1	5169,9	5336,2	5484,4	5614,0	5724,5	5815,6	5886,7	5937,8	5968,5	5978,7							
550	743,1	1111,7	1476,8	1837,2	2191,7	2539,3	2878,7	3209,0	3529,1	3837,8	4134,2	4417,4	4686,4	4940,2	5178,1	5399,2	5602,8	5788,1	5954,6	6101,6	6228,7	6335,3	6421,0	6485,6	6528,8	6550,5							
560	798,7	1195,0	1587,6	1975,4	2357,1	2731,6	3097,7	3454,2	3800,1	4134,3	4455,7	4763,3	5056,1	5333,2	5593,7	5836,7	6061,5	6267,3	6453,3	6619,1	6763,9	6887,4	6989,0	7068,4	7125,3	7159,6	7171,0						
570	857,4	1282,9	1704,6	2121,3	2531,7	2934,6	3328,8	3713,1	4086,3	4447,4	4795,3	5128,8	5446,9	5748,8	6033,3	6299,7	6547,0	6774,6	6981,6	7167,5	7331,5	7473,1	7591,9	7687,4	7759,3	7807,4	7831,5						
580	919,2	1375,5	1827,9	2275,1	2715,7	3148,6	3572,5	3986,1	4388,3	4777,9	5153,7	5514,6	5859,6	6187,7	6497,8	6789,0	7060,4	7311,2	7540,6	7748,0	7932,5	8093,7	8231,0	8344,0	8432,3	8495,6	8533,6	8546,3					
590	984,3	1473,1	1957,7	2437,0	2909,6	337																											

VAST RAAM
CHASSIS FIXE
FEST FIELD
FIXED WINDOW

ZAAGTABELLEN - TABLES DE SCIAGES - ZUSCHNITT-TABELLEN - SAWING TABLES

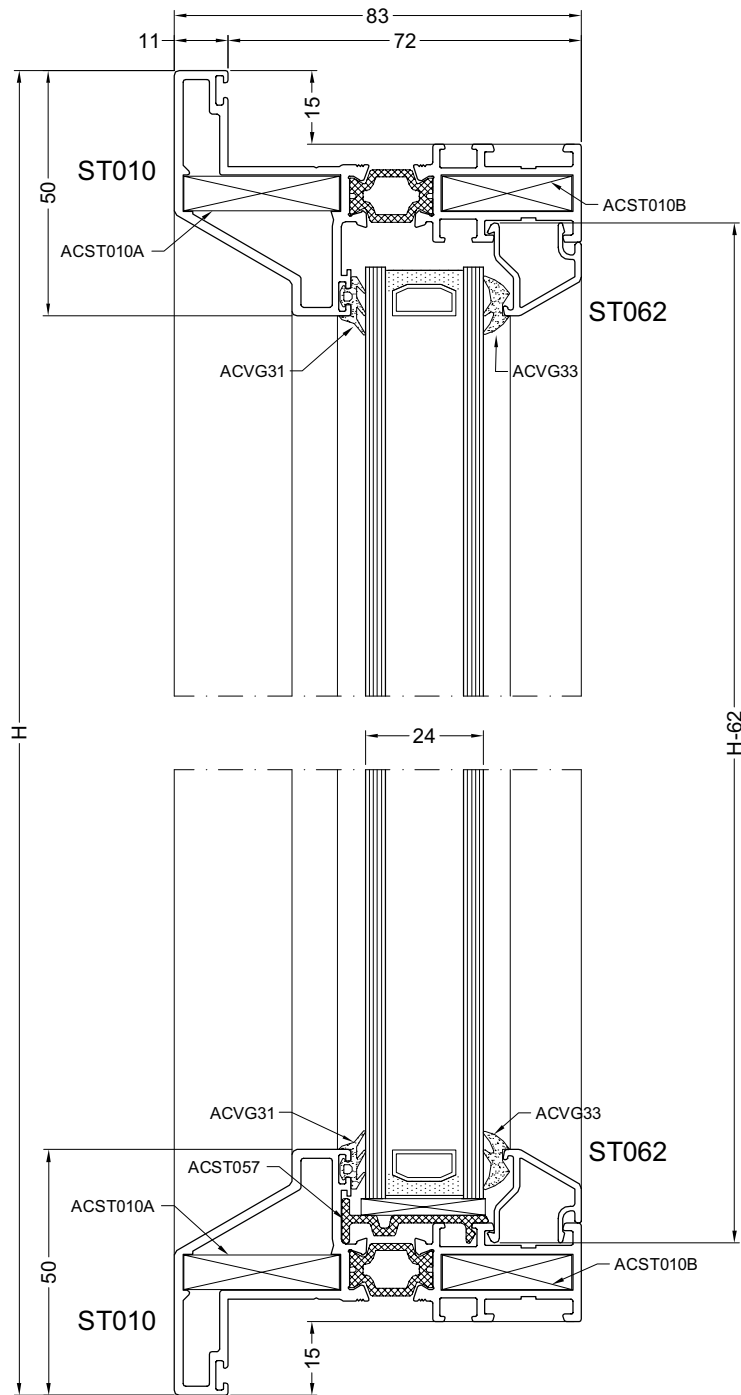

PROFIELEN PROFILS PROFILE PROFILES

ST010		2		B
ST010		2		H
ST062		2		B - 62
ST062		2		H - 62

TOEBEHOREN ACCESSOIRES
ZUBEHORTEILE ACCESSORIES

ACST010A	4
ACST010B	4
ACST057	4
ACVG31	2B + 2H -250
ACVG3*	2B + 2H -250

GLASMATEN DIMENSIONS DES VITRAGES GLASSMASSE GLASS SIZES	B - 80 H - 80
---	------------------

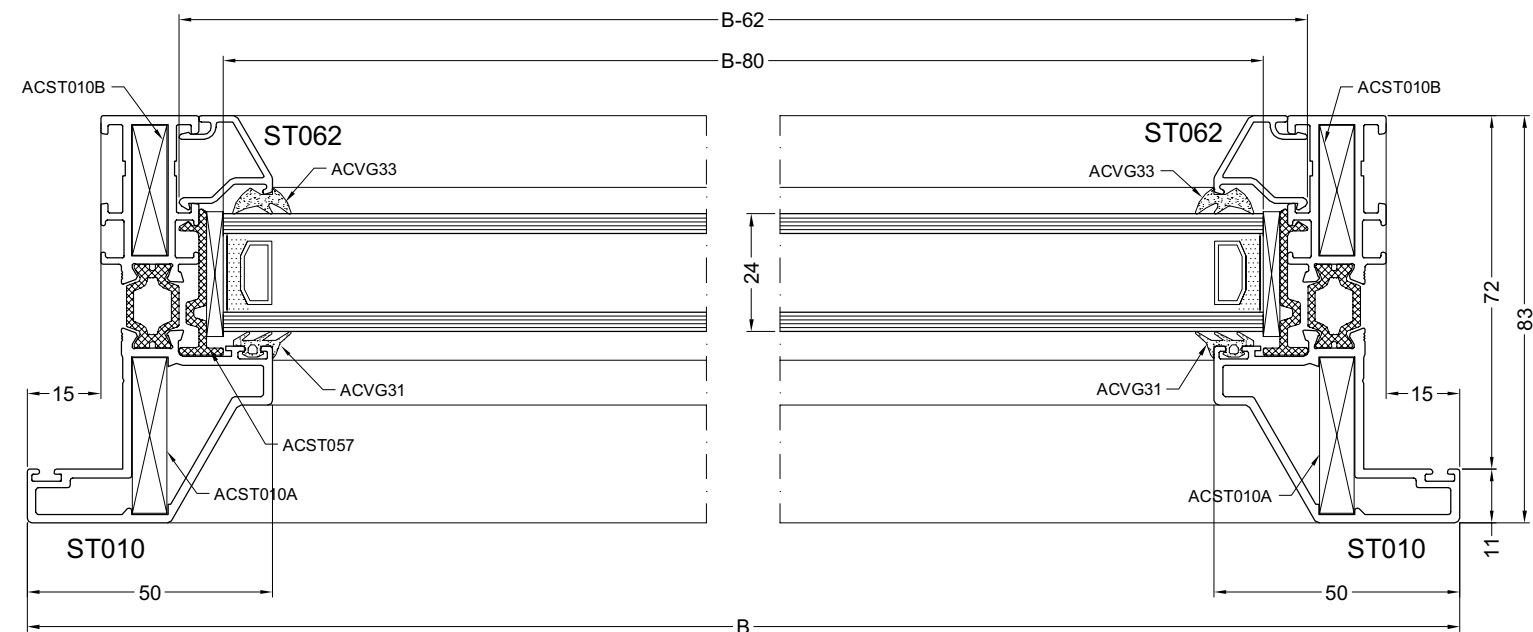
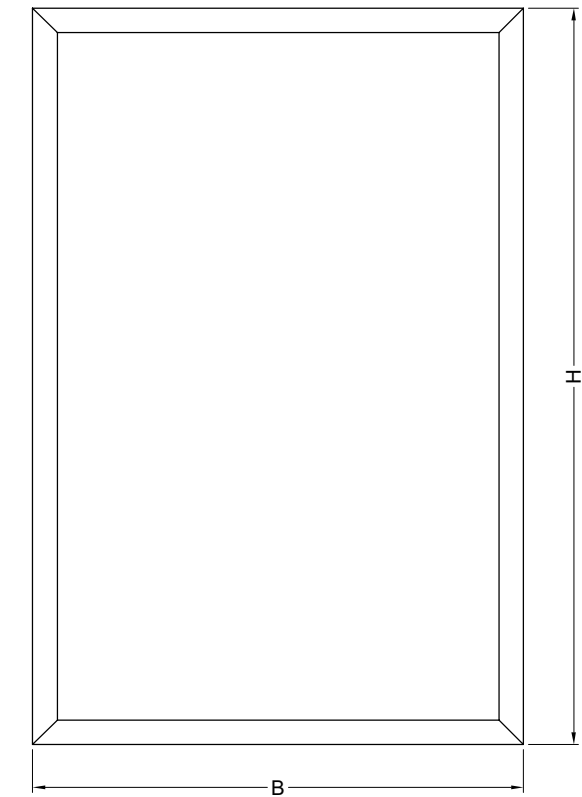

zaag1

STOLPRAAM
DOUBLE OUVRANT A LA FRANCAISE
STULPFENSTER
DOUBLE CASEMENT WINDOW

ZAAGTABELLEN - TABLES DE SCIAGES - ZUSCHNITT-TABELLEN - SAWING TABLES

PROFIELEN PROFILS PROFILE PROFILES

ST010		2		B
ST010		2		H
ST020		4		B/2 - 32.5
ST020		4		H - 60
ST040		1		Hv - 68
ST060		2		B - 65
ST060		2		H - 65
ST062		4		B/2 - 104.5
ST062		4		H - 132
VL59		1		X - 100
VL59		1		H - (X + 160)
VL59		1		Y - 175
VL59		1		H - (Y + 203)

ZUBEHÖRTEILE ACCESSORIES

ACST010A	4
ACST010B	4
ACST020A	8
ACST020B	8
ACST057	10
ACVG31	4H+2B-1200
ACVG3*	4H+2B-1200
ACMX040	4 OF/OU 6
ACFA081	1
ACFA050	1 SET
ACFA051	1
ACFA083	1
ACST054	1 SET
ACFA055/056	1 SET
ACVL031	3H+2B-200
ACVL030	3H+2B-200

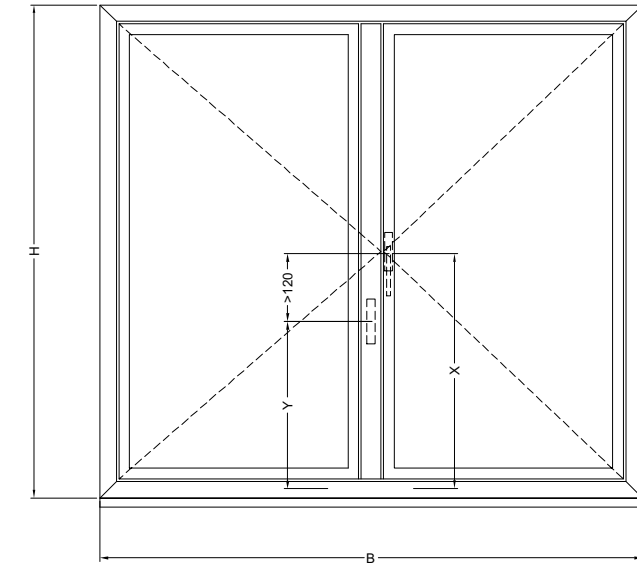
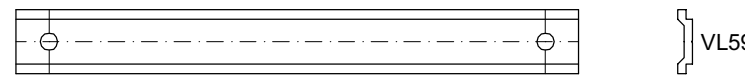
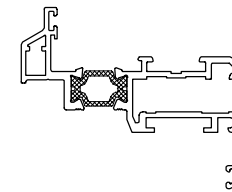
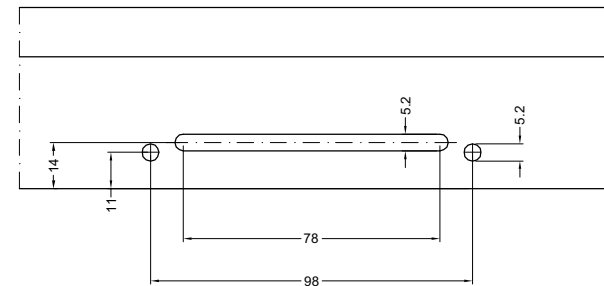
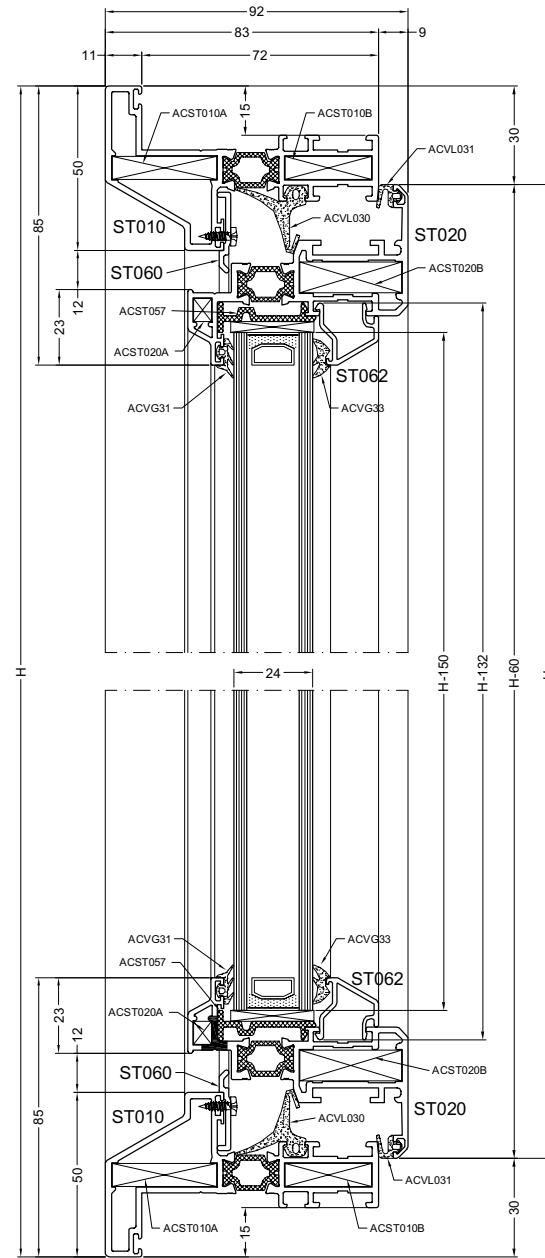

GLASMATEN DIMENSIONS DES VITRAGES B/2 - 122
GLASSMASSE GLASS SIZES H - 150

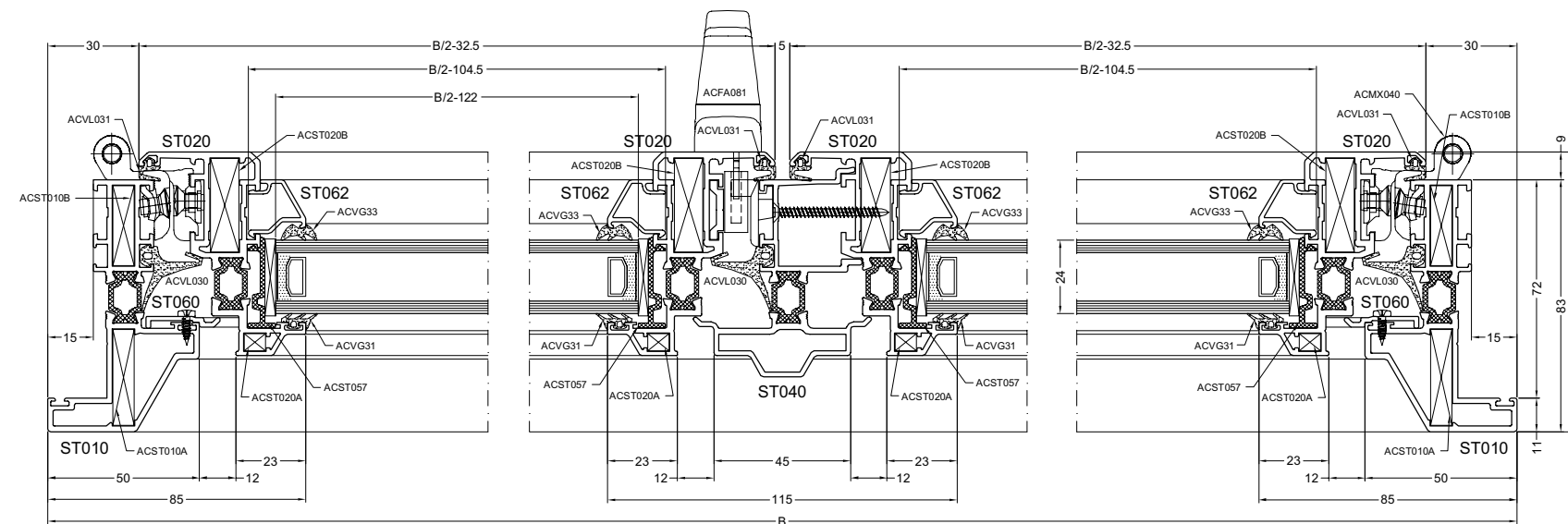

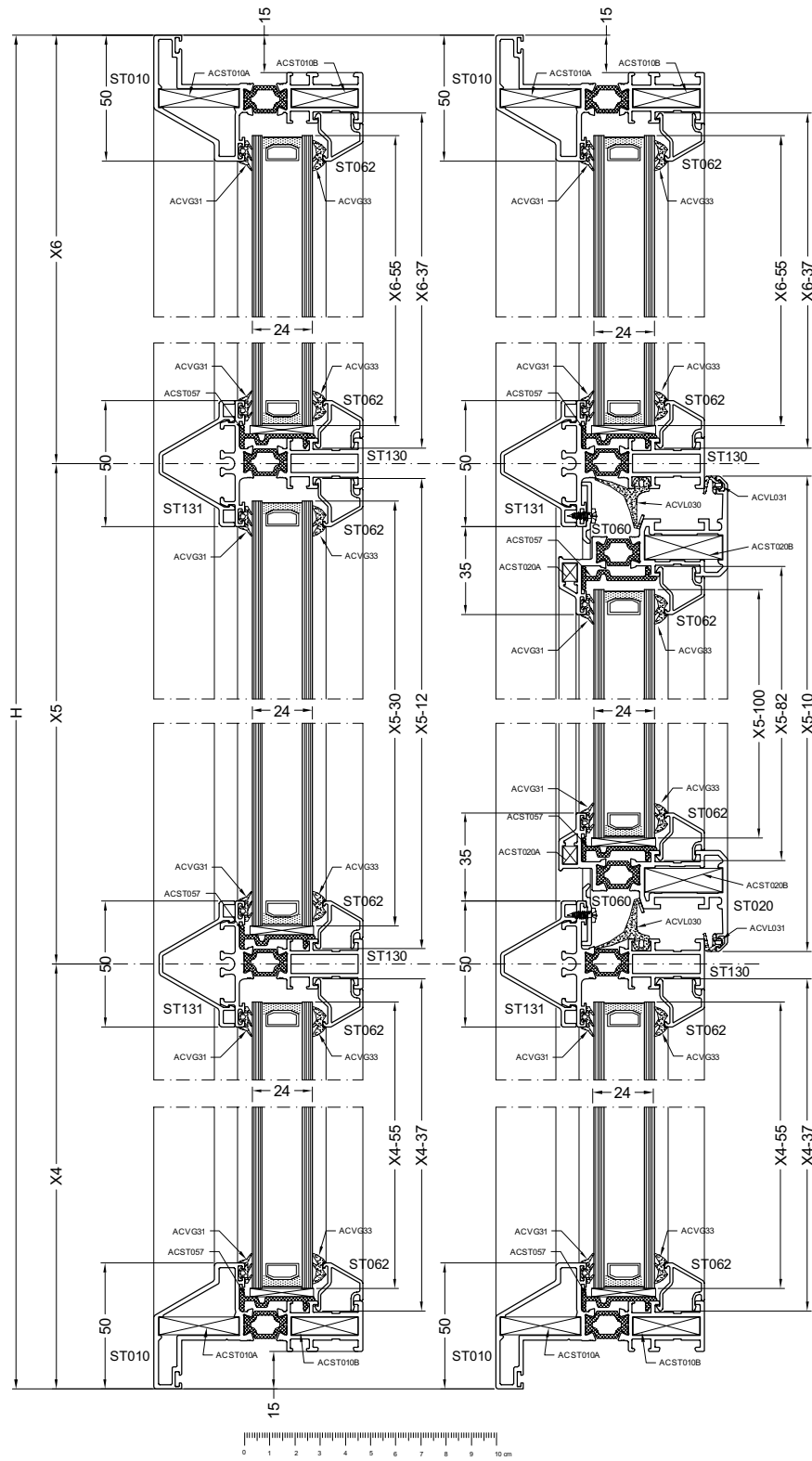

PROFIELN PROFILS PROFILE PROFILS

ST010	2		B
ST010	2		H
ST020	2		X2 - 10
ST020	2		X5 - 10
VL59	1		X - 100
VL59	1		X5 - (X + 110)
ST060	2		X2 - 15
ST060	2		X5 - 15
ST062	6		X1 - 37
ST062	4		X2 - 12
ST062	2		X2 - 82
ST062	6		X3 - 37
ST062	6		X4 - 37
ST062	4		X5 - 12
ST062	2		X5 - 82
ST062	6		X6 - 37
ST030	2		H - 60
ST130	2		X1 - 45
ST130	2		X2 - 20
ST130	2		X3 - 45
ST131	2		X1 - 35.5
ST131	2		X2 - 10
ST131	2		X3 - 35.5

TOEBEHOREN ACCESSOIRES
ZUBEHÖRTEILE ACCESSORIES

ACST010A	4
ACST010B	4
ACST020A	4
ACST020B	4
ACST030	8
ACST031	8
ACST032	12
ACST057	37
ACVG31	6B + 6H - 500
ACVG3*	6B + 6H - 500
ACMX040	2 OF/OU 3
ACFA081	1
ACFA050	1 SET
ACFA051	1
ACFA083	1
ACVL031	2X2 + 2X5
ACVL030	2X2 + 2X5

GLASMATEN	3	X1 - 55
DIMENSIONS DES VITRAGES	2	X2 - 30
GLASMASSE	1	X2 - 100
GLASS SIZES	3	X3 - 55
	3	X4 - 55
	2	X5 - 30
	1	X5 - 100
	3	X6 - 55

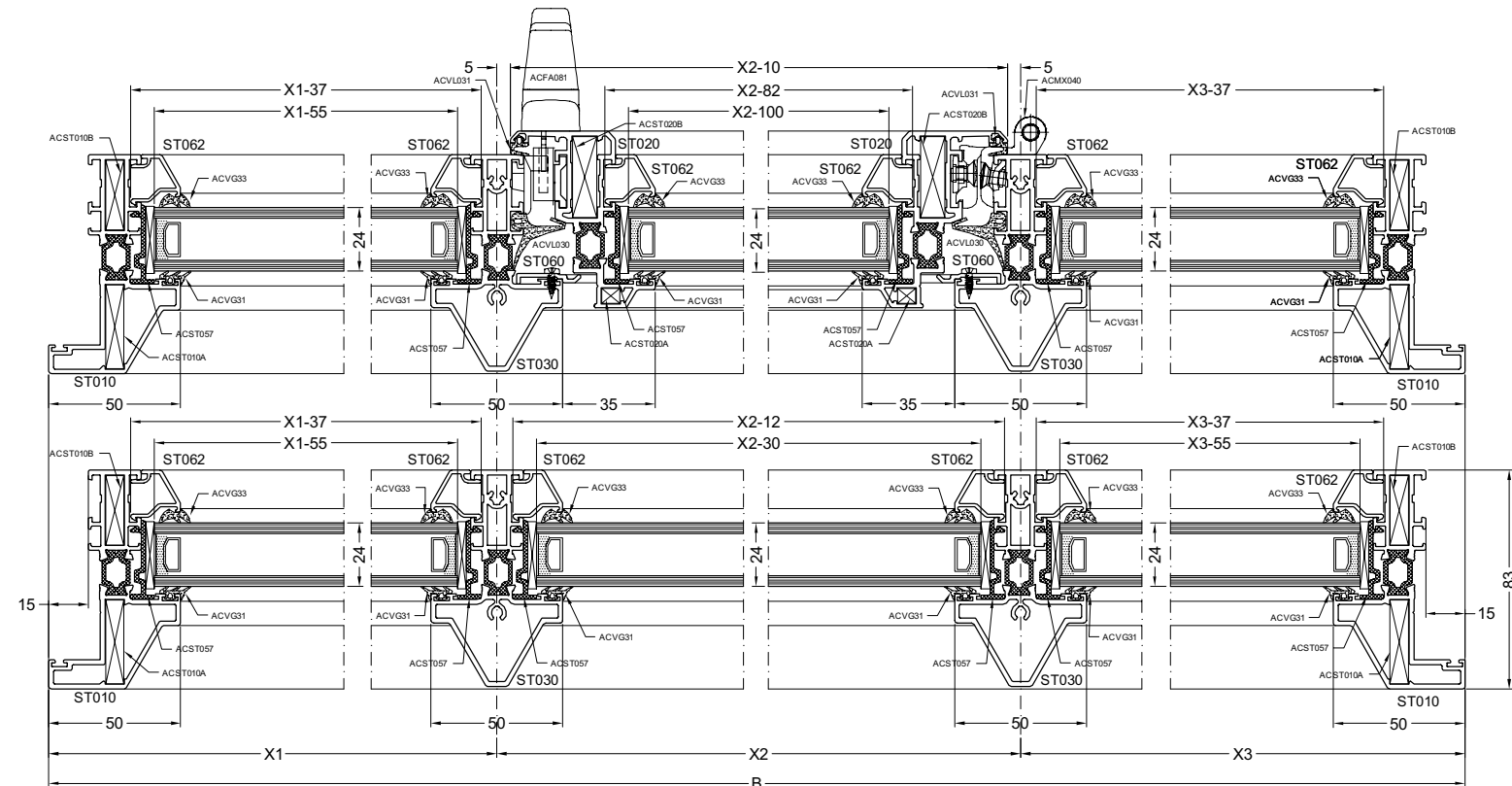
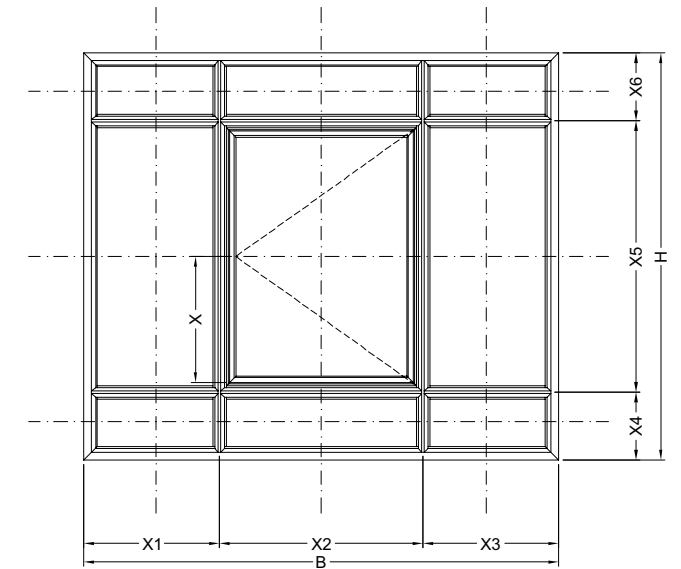
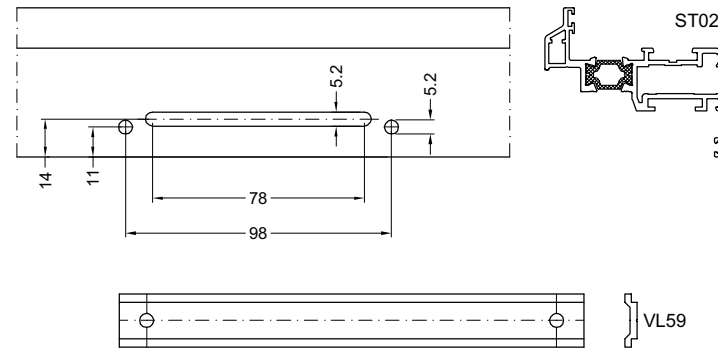

ENKELE DEUR
PORTE SIMPLE
ANSCHLAGTUR
SINGLE DOOR

ZAAGTABELLEN - TABLES DE SCIAGES - ZUSCHNITT-TABELLEN - SAWING TABLES

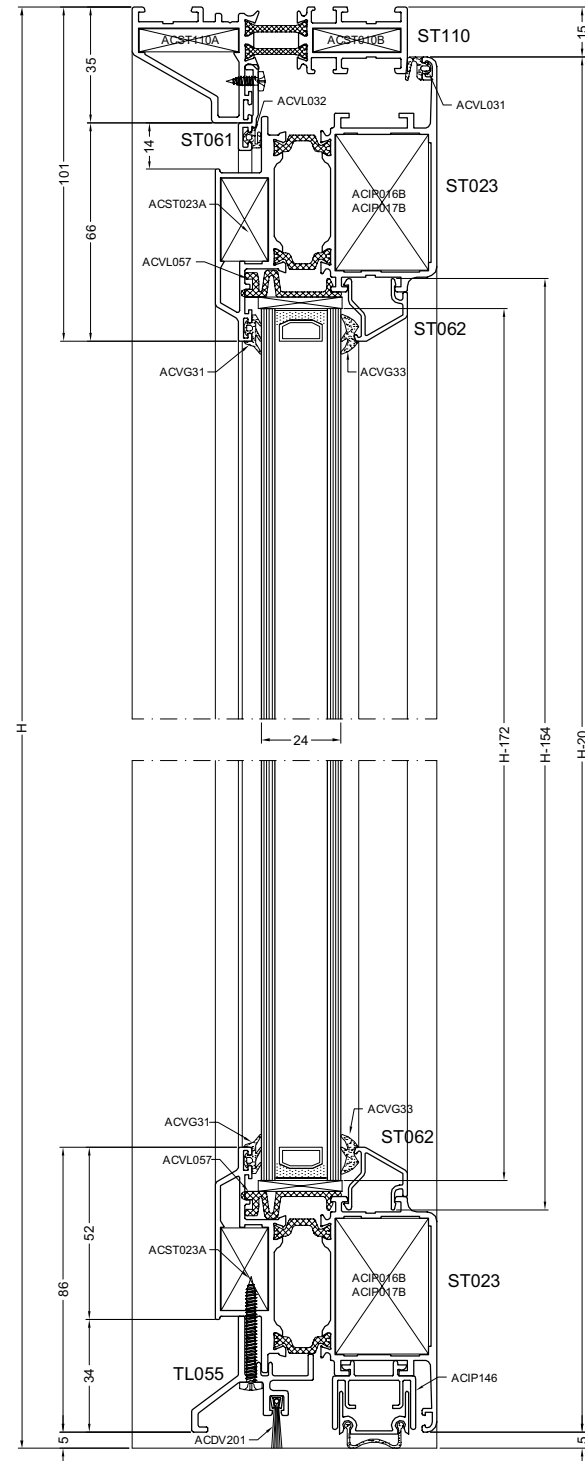

PROFIELEN PROFILS PROFILE PROFILES

ST110		1		B
ST110		1		H
ST110		1		H
ST023		2		B - 30
ST023		2		H - 20
ST062		2		B - 164
ST062		2		H - 154
ST061		1		B - 35
ST061		1		H - 17.5
ST061		1		H - 17.5
TL055		1		B - 104

TOEBEHOREN ACCESSOIRES
ZUBEHÖRTEILE ACCESSORIES

ACST110A	2
ACST010B	2
ACST023A	4
ACIP016B/017B	4
ACVL057	4
ACTL443	1
ACMX102	2
ACFA120	2
ACFA121	1/5
ACMX861	1/5
ACMX309	1
ACMX208S	2
ACMX01613	1
ACVL707	1
ACVG31	2H + 2B -500
ACVG3*	2H + 2B -500
ACVL031	2H + B
ACVL032	2H + B

BORSTELDICHTING BRASSE DESSOUS
BURSTENDICHTUNG BRUSH FITTING
ACDV201 1 B-73

ACIP146/147/148/149	1	L=B-73
ACIP146	Lmin=560mm	Lmax=710mm
ACIP147	Lmin=685mm	Lmax=835mm
ACIP148	Lmin=810mm	Lmax=960mm
ACIP149	Lmin=935mm	Lmax=1085mm

GLASMATEN DIMENSIONS DES VITRAGES
GLASMASSE GLASS SIZES
B - 182
H - 172

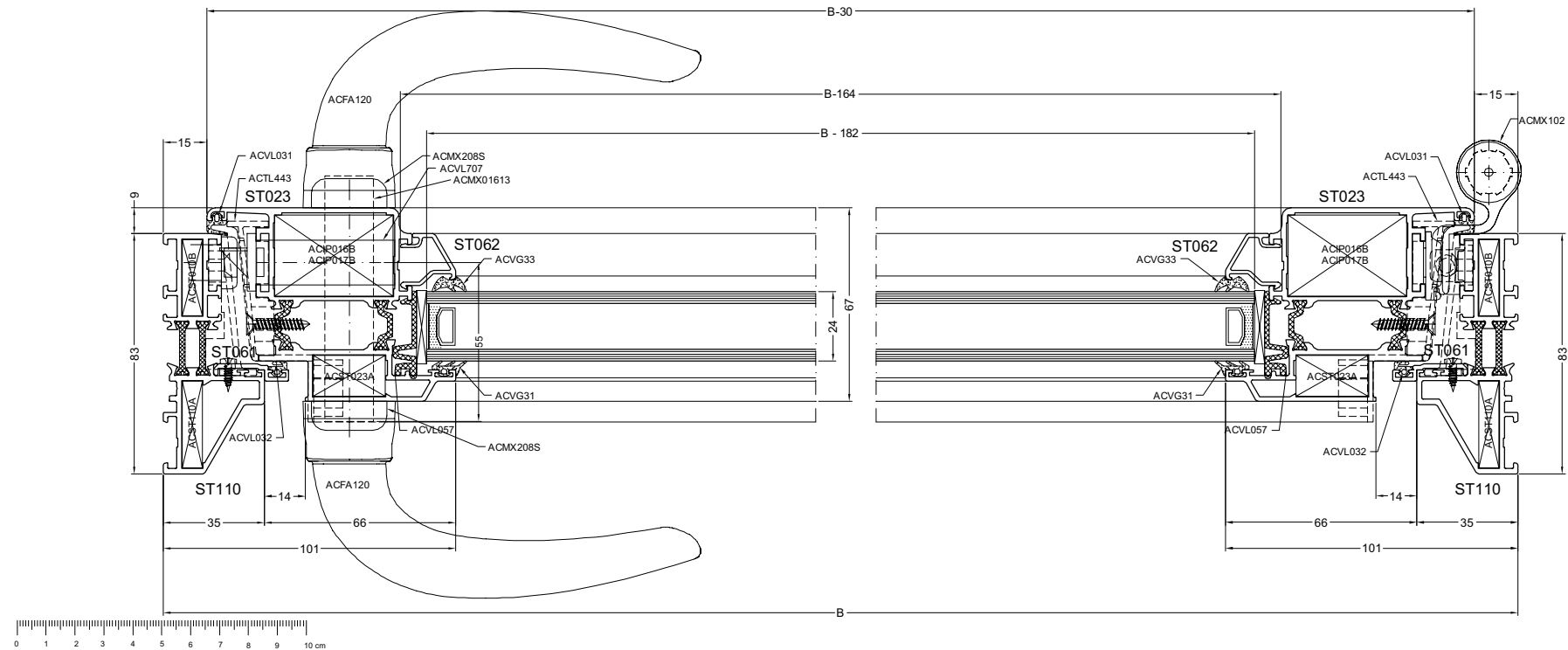
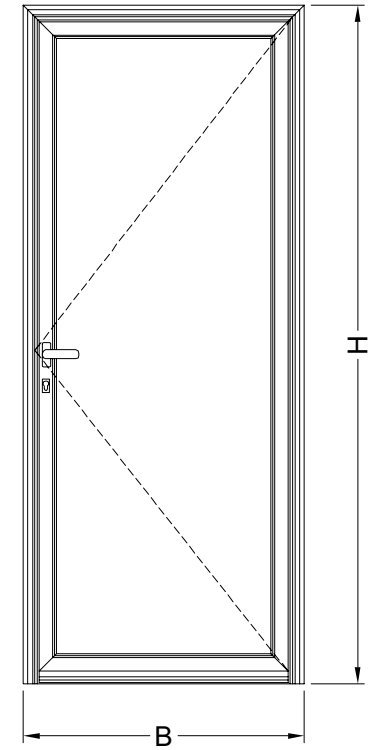

ENKELE DEUR
PORTE SIMPLE
ANSCHLAGTUR
SINGLE DOOR

ZAAGTABELLEN - TABLES DE SCIAGES - ZUSCHNITT-TABELLEN - SAWING TABLES

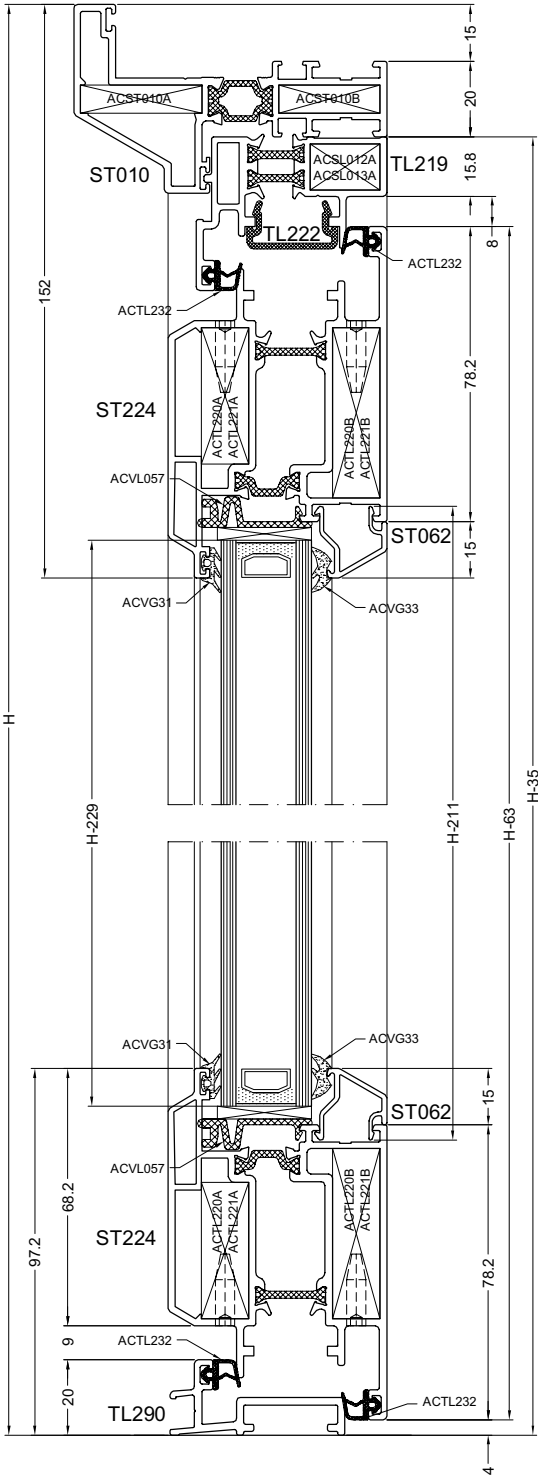

PROFIELEN PROFILES PROFILE PROFILS

ST010		1		H
ST010		1		H
ST010		1		B
TL219		1		H - 35
TL219		1		H - 35
TL219		1		B - 70
ST224		2		B - 118
ST224		2		H - 63
ST*62		2		B - 266
ST*62		2		H - 211
TL290		1		B - 129
TL222		1		B - 118
TL222		2		H - 75
TL222		1		H - 97

TOEBEHOREN ACCESSOIRES
ZUBEHÖRTEILE ACCESSORIES

ACST010A	2
ACST010B	2
ACSL012A/013A	2
ACTL220A/221A	4
ACTL220B/221B	4
ACVL057	4
ACTL202	2 of/ou/oder/or 3
ACFA120	2
ACFA121	1/5
ACMX860	1/5
ACMX208	1
ACMX209	1
ACTL215	1
ACMX01611	1
ACTL225	2
ACTL232	4B + 4H - 600
ACVG31	2B + 2H - 1000
ACVG3*	2B + 2H - 1000

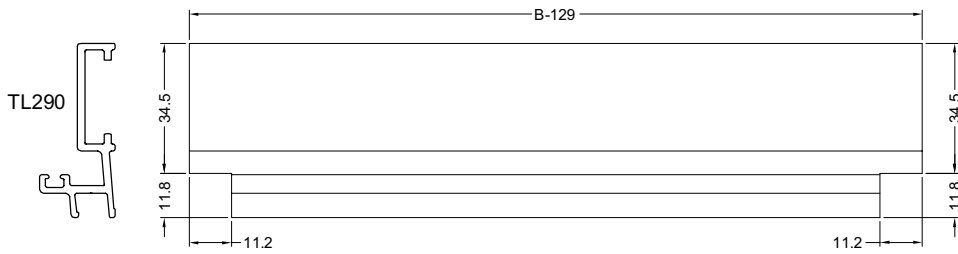

GLASMATEN
DIMENSIONS DES VITRAGES B - 284
GLASSMASSE
GLASS SIZES H - 229

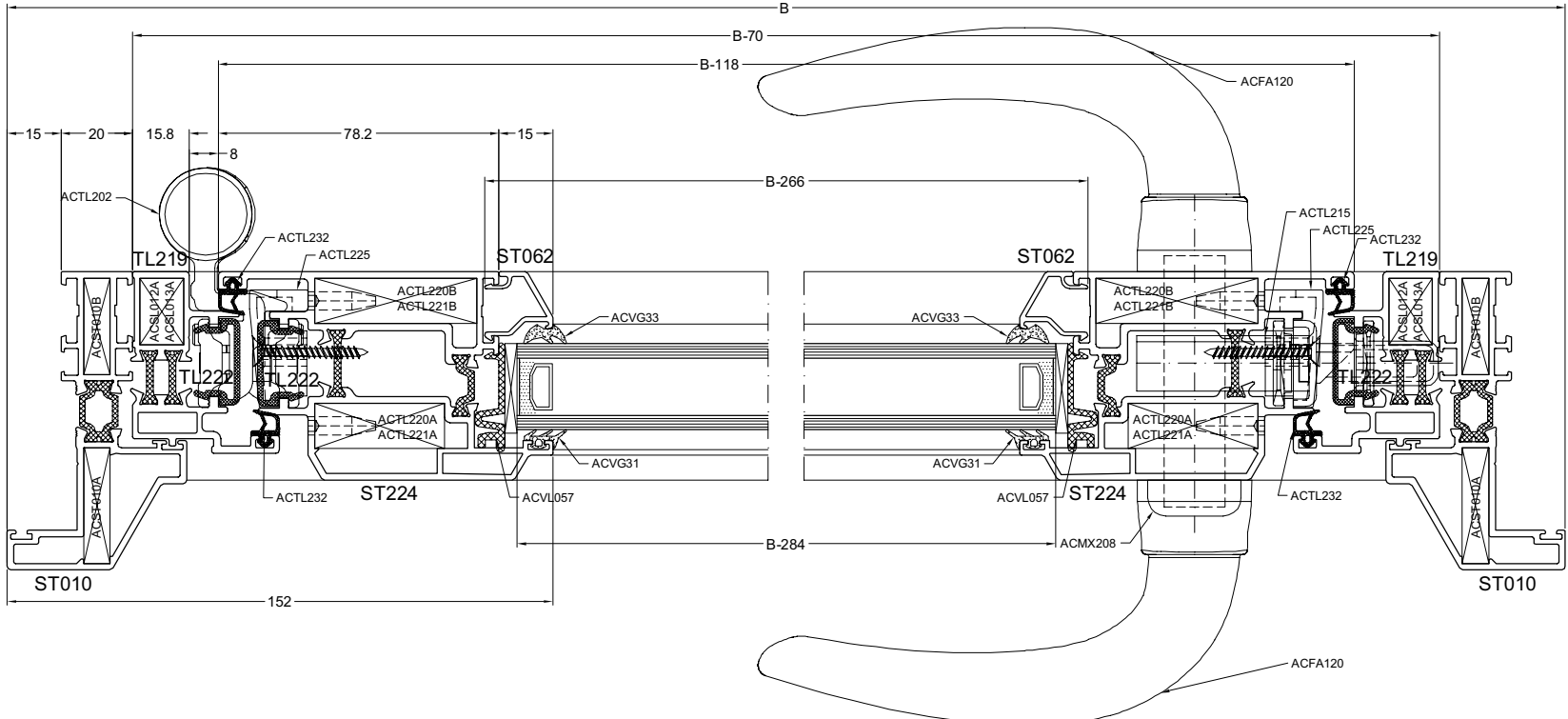
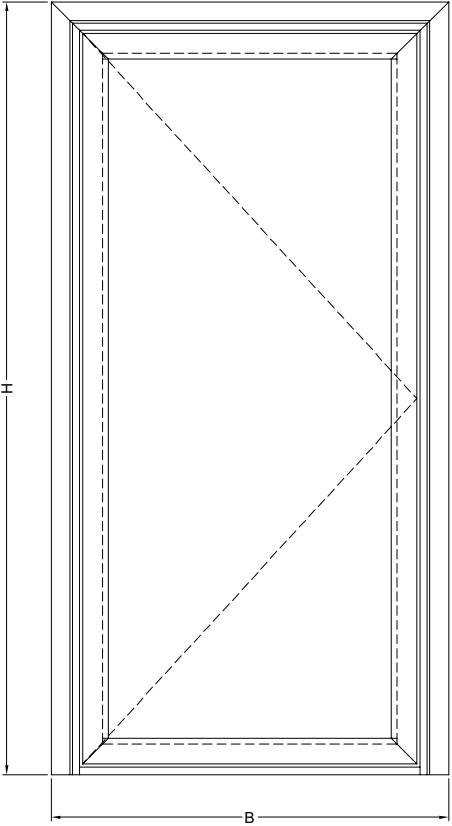

deurbinnen

ENKELE DEUR
PORTE SIMPLE
ANSCHLAGTUR
SINGLE DOOR

ZAAGTABELLEN - TABLES DE SCIAGES - ZUSCHNITT-TABELLEN - SAWING TABLES

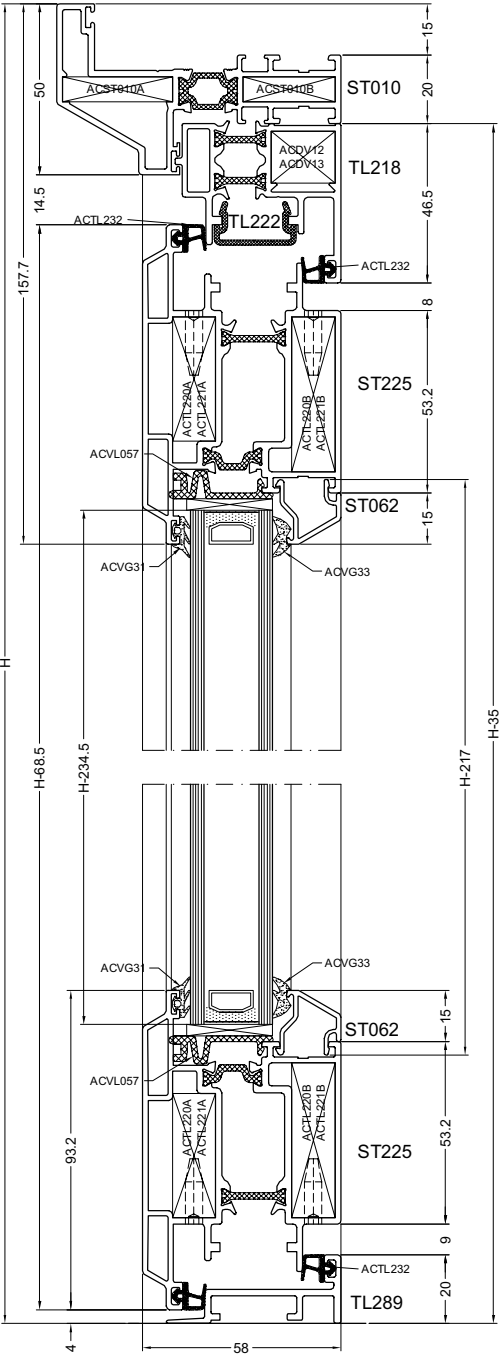

PROFIELEN PROFILES PROFILE PROFILS

ST010		1		H
ST010		1		H
ST010		1		B
TL218		1		H - 35
TL218		1		H - 35
TL218		1		B - 70
ST225		2		B - 129
ST225		2		H - 68.5
ST*62		2		B - 277
ST*62		2		H - 217
TL289		1		B - 100
TL222		1		B - 129
TL222		2		H - 80.5

TOEBEHOREN ACCESSOIRES
ZUBEHÖRTEILE ACCESSORIES

ACST010A	2
ACST010B	2
ACDV12/13	2
ACTL220A/221A	4
ACTL220B/221B	4
ACVL057	4
ACTL202	2 of/ou/oder/or 3
ACFA120	2
ACFA121	1/5
ACMX860	1/5
ACMX208	1
ACMX209	1
ACTL215	1
ACMX01611	1
ACTL225	2
ACTL232	4B + 4H - 600
ACVG31	2B + 2H - 1000
ACVG3*	2B + 2H - 1000

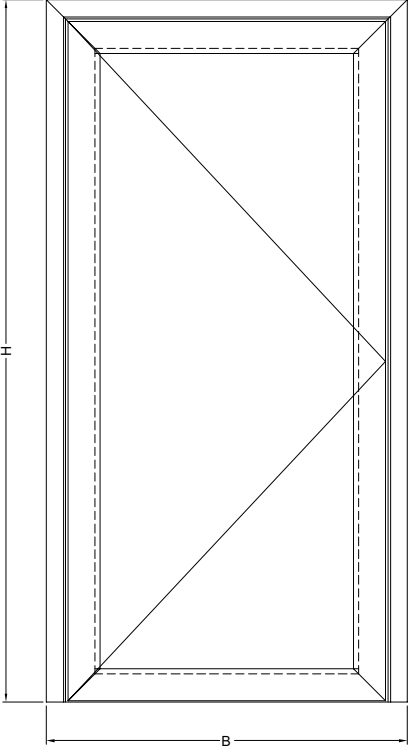
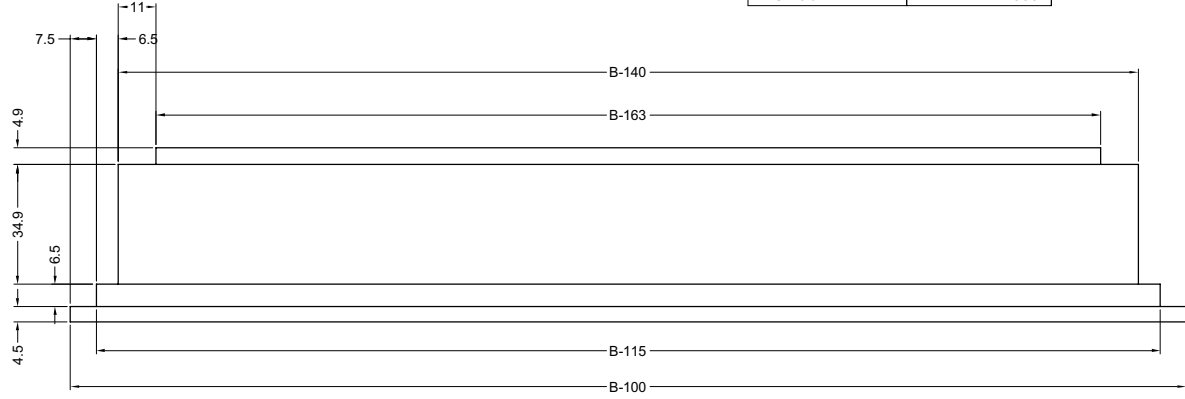

GLASMATEN
DIMENSIONS DES VITRAGES
GLASSMASSE
GLASS SIZES
B - 295
H - 234.5

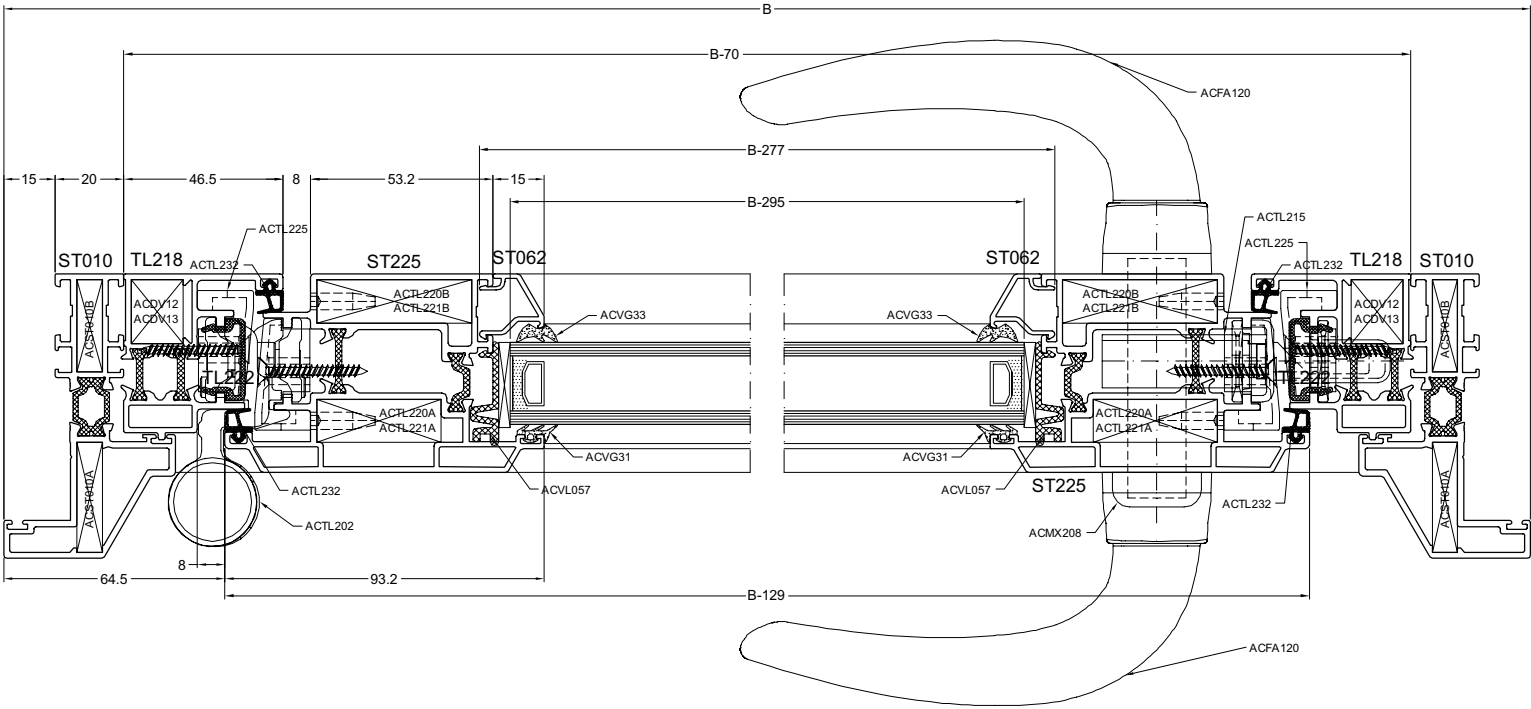

deurbuiten

TOEPASSINGSBEREIK OPENDRAAIEND RAAM
PORTEE D'UTILISATION OUVRANT A LA FRANCAISE
ANWENDUNGSBEREICH DREHFLUGEL
APPLICATION LIMIT CASEMENT WINDOW

WERKTEKENINGEN - DESSINS DE CONSTRUCTION - KONSTRUKTIONZEICHNUNGEN - CONSTRUCTION DRAWINGS

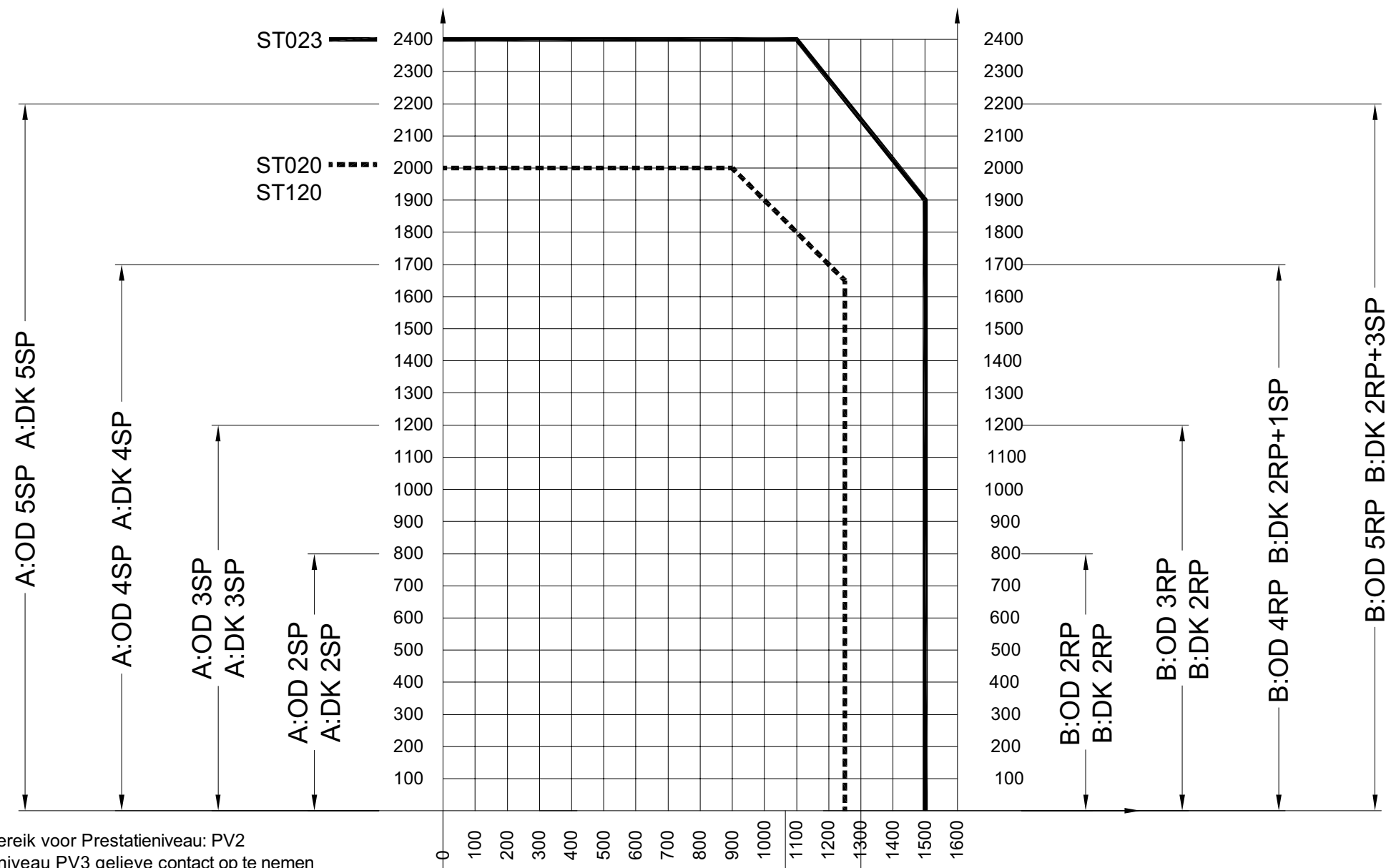

Hang- en sluitwerk
Quincaillerie
Beschlage
Hardware

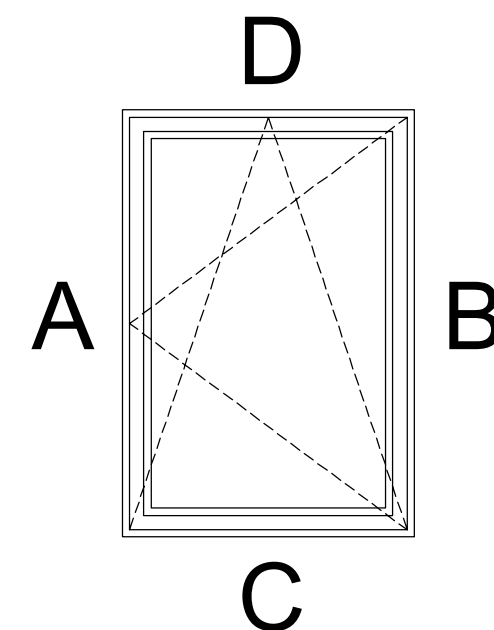

Toepassingsbereik voor Prestatieniveau: PV2
Voor prestatieniveau PV3 gelieve contact op te nemen
Max. vleugelgewicht: 90 kg

Portée d'utilisation pour niveau de performance: PV2
Pour PV3 veuillez nous contacter
Poids max. de l'ouvrant: 90 kg

Anwendungsbereich für das Niveau der Leistung: PV2
Für PV3 Bitte kontaktieren Sie Uns
Max. Gewicht der Flügel: 90 kg

Application limit for performance level: PV2
For PV3 please contact us
Max. weight for opening part: 90 kg

hangwerk

C&D zonder SP
C&D sans SP
C&D ohne SP
C&D without SP

C&D met 1 SP
C&D avec 1 SP
C&D mit 1 SP
C&D with 1 SP

A,B,C,D: vleugelprofiel - profil de vantail - flügelprofil - sash profile
OD: opendraaiend raam - fenêtre ouvrante - drehflügel - casement window
DK: draai-kip venster - fenêtre oscillo-battante - drehkip fenster - turn and tilt window
SP: sluitpunt - point de fermeture - schlusspunkt - lock point
RP: rotatiepunt - point de rotation - rotation punkt - rotation point

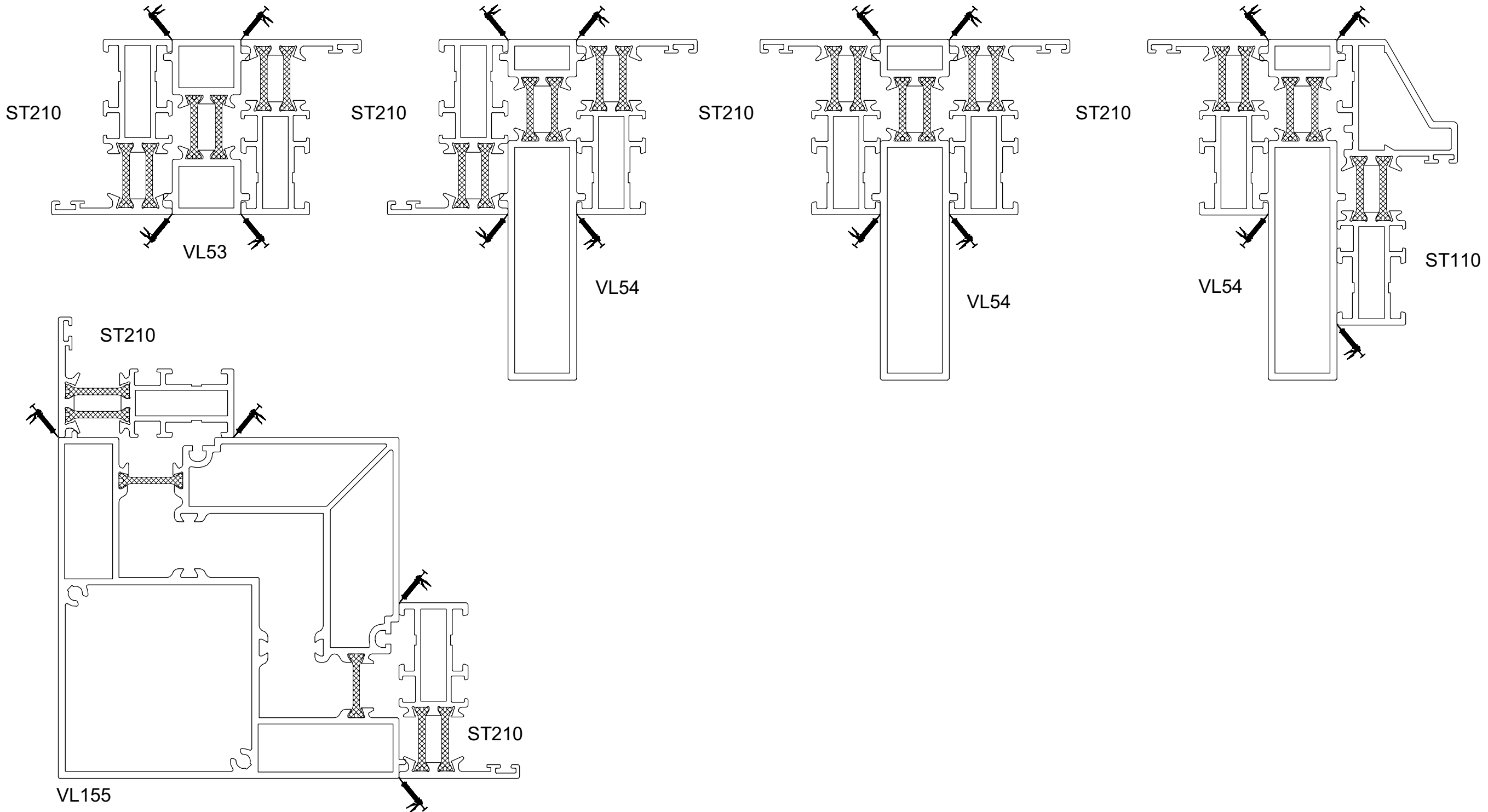

MONTAGE ST030
MONTAGE ST030
MONTAGE ST030
MONTAGE ST030

WERKTEKENINGEN - DESSINS DE CONSTRUCTION - KONSTRUKTIONZEICHNUNGEN - CONSTRUCTION DRAWINGS

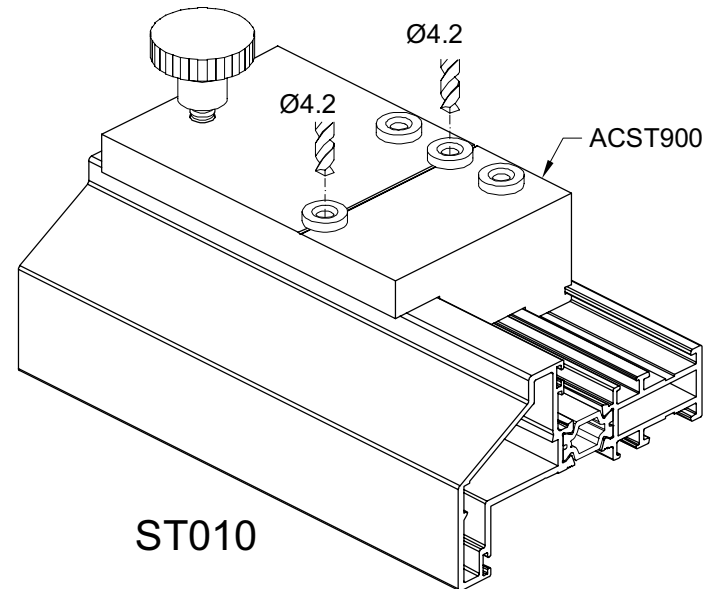

1. Ontvetten van zaagsnede
Degraisser les coupes
Entfetten der Sageschnitt
Degrease saw cut
2. Afkitten met ACSIL04
Colmater avec ACSIL04
Abdichten mit ACSIL04
Seal with ACSIL04
3. Lijmen in profiel met ACSIL013 (met pistool ACSIL08)
Coller dans les chambres avec ACSIL013 (pistolet ACSIL08)
ACSIL013 klebstoff im profil (kleber pistol ACSIL08)
Glue with ACSIL013 in profile (pistol ACSIL08)

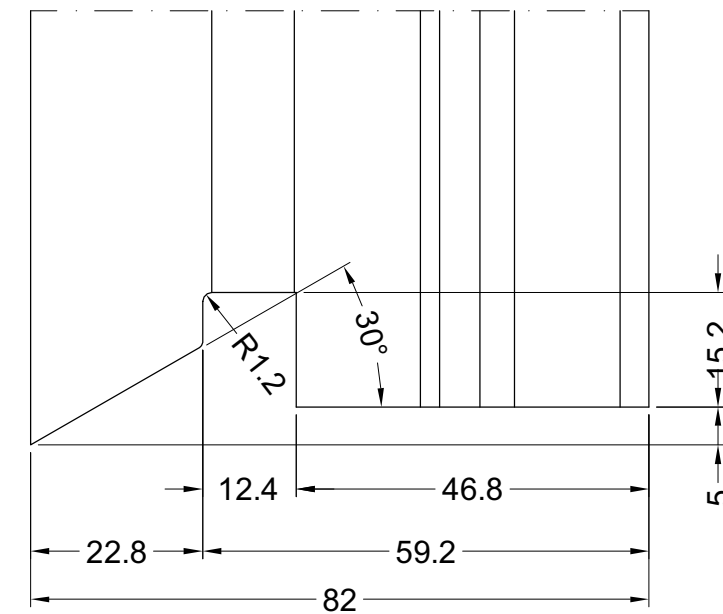
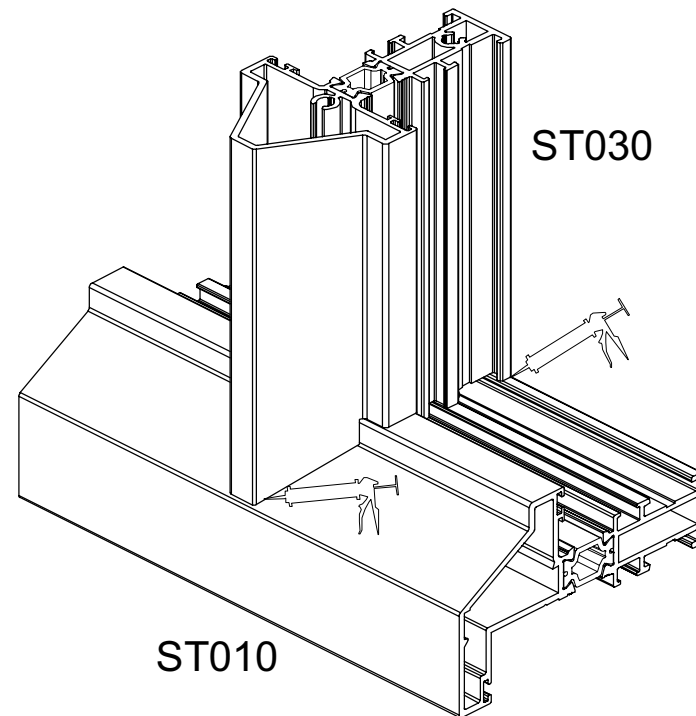
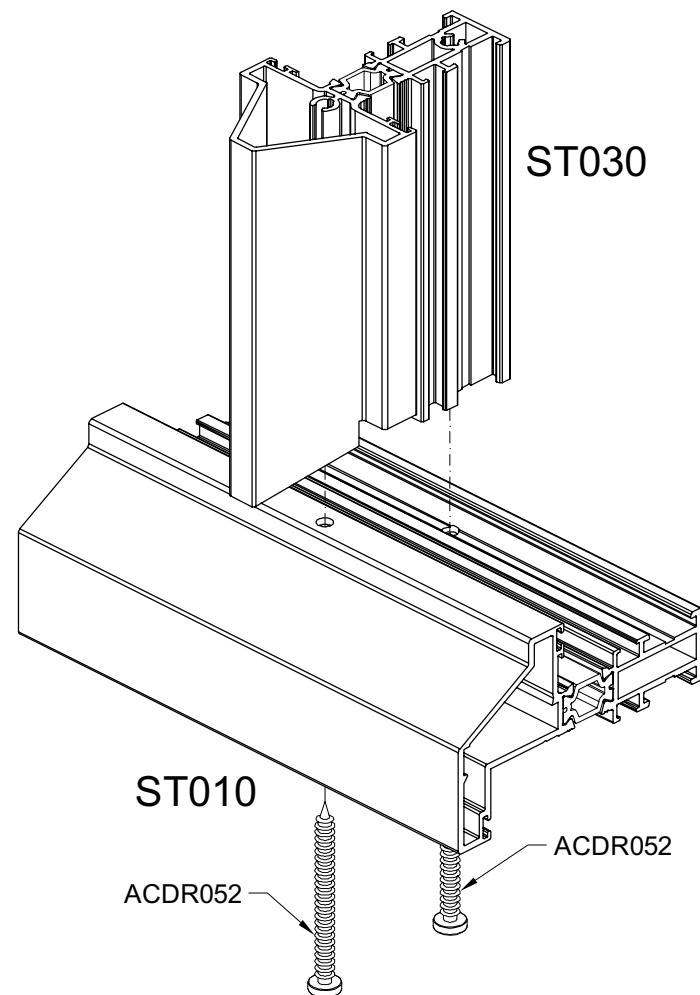
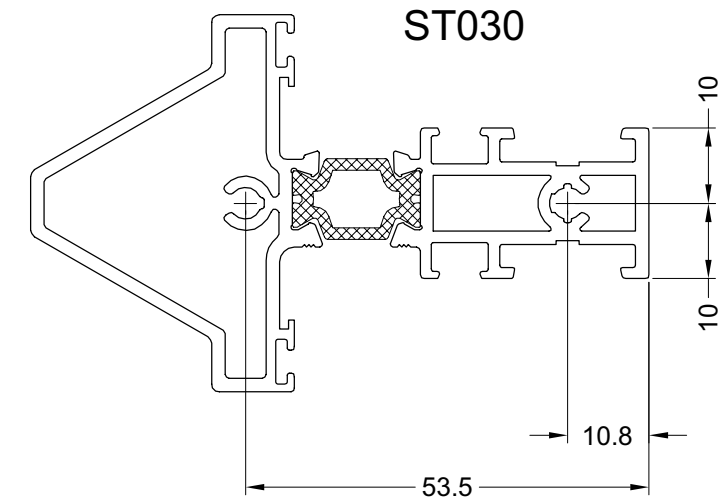

MONTAGE ACST032
MONTAGE ACST032
MONTAGE ACST032
MONTAGE ACST032

WERKTEKENINGEN - DESSINS DE CONSTRUCTION - KONSTRUKTIONZEICHNUNGEN - CONSTRUCTION DRAWINGS

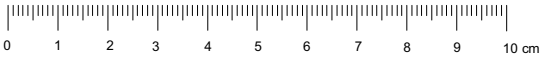
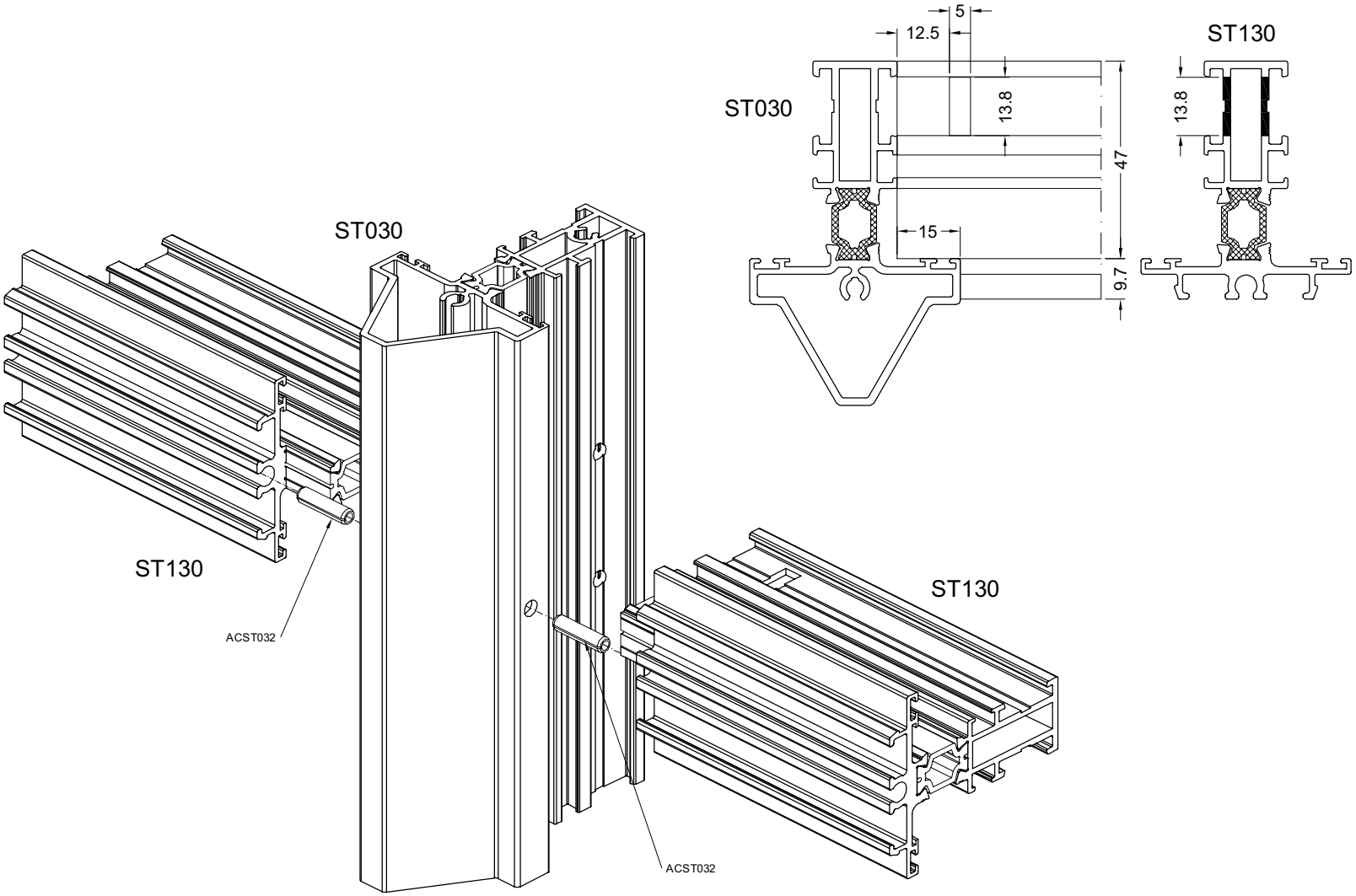
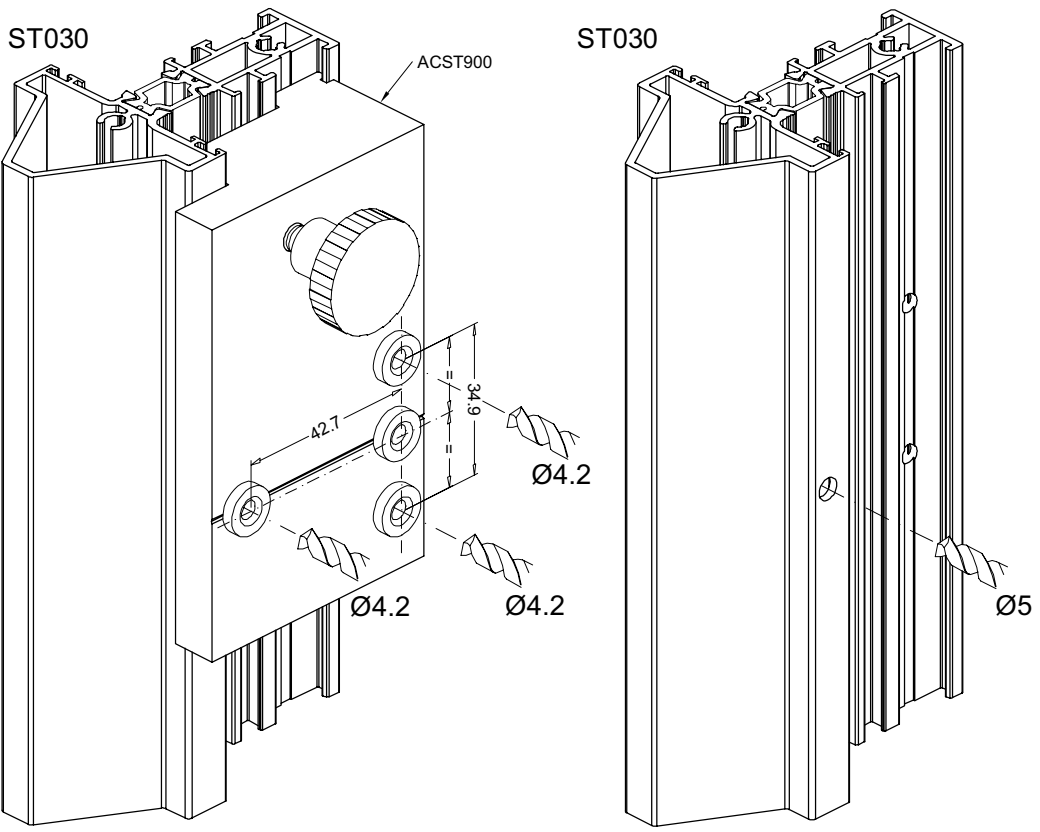

Tprof1

MONTAGE ACST032
MONTAGE ACST032
MONTAGE ACST032
MONTAGE ACST032

WERKTEKENINGEN - DESSINS DE CONSTRUCTION - KONSTRUKTIONZEICHNUNGEN - CONSTRUCTION DRAWINGS

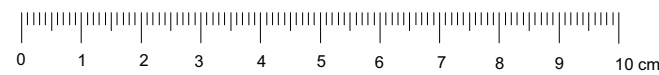
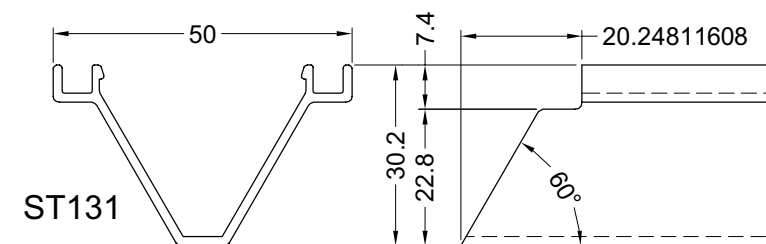
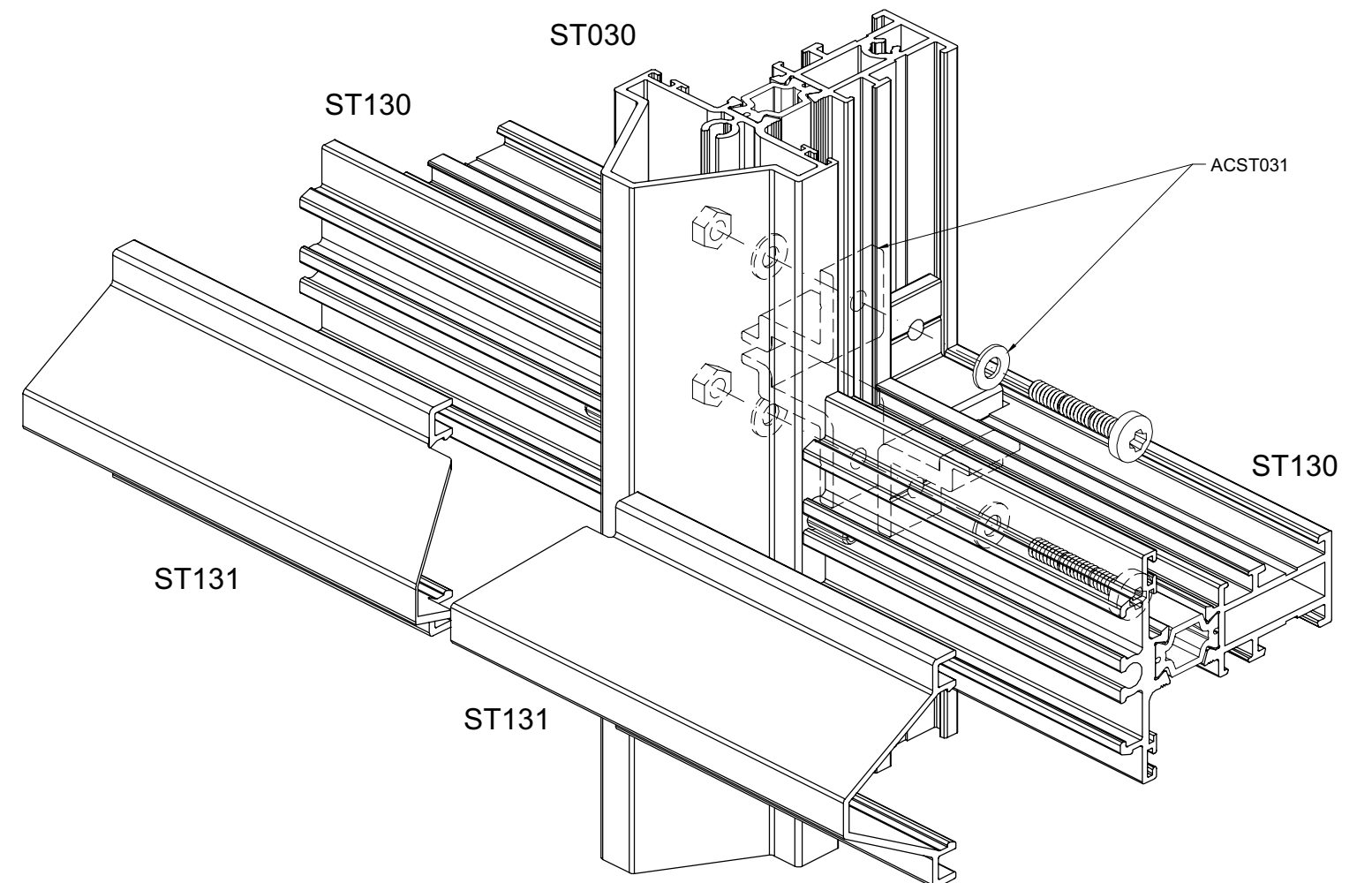
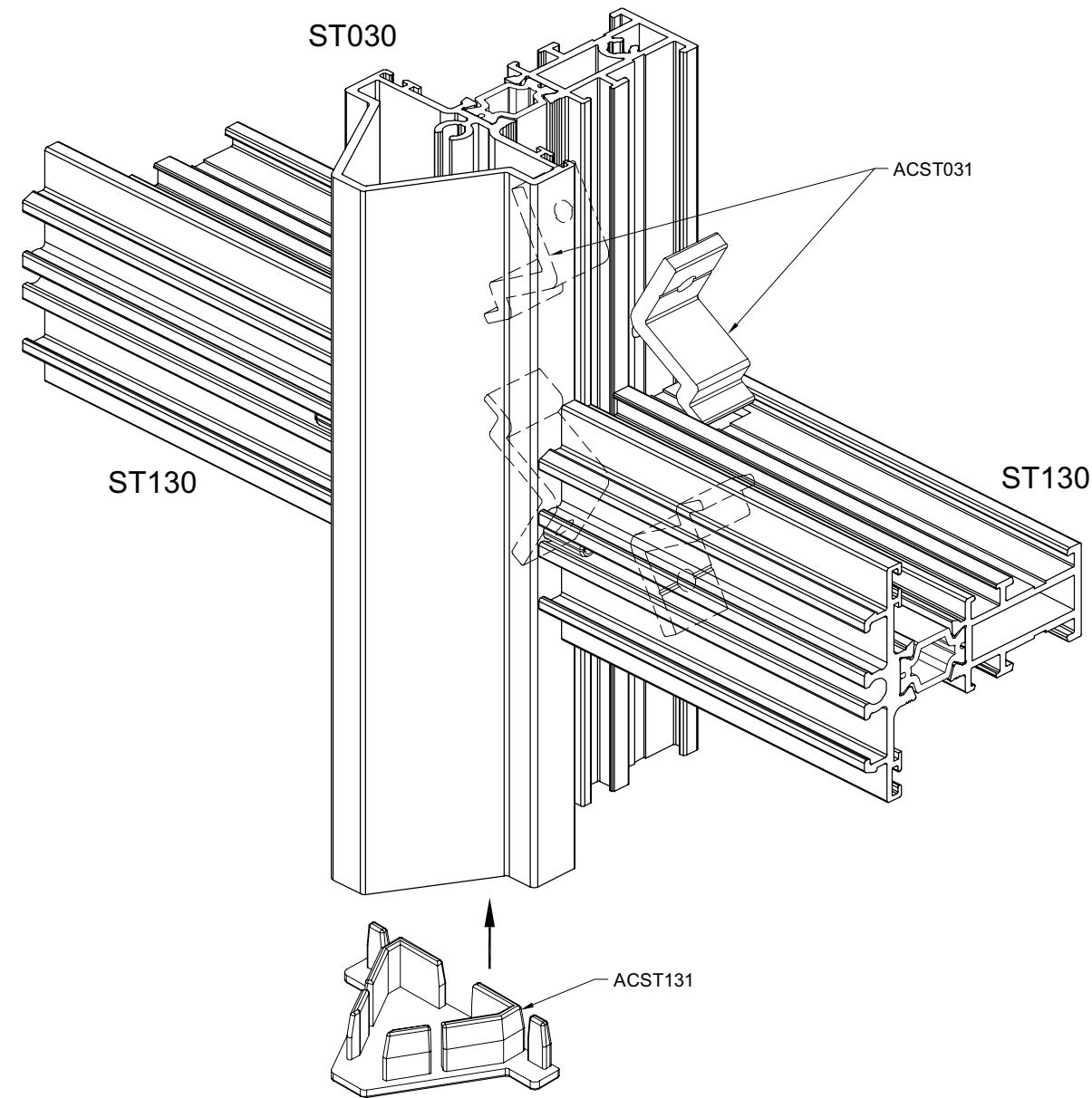

MONTAGE ACST032
MONTAGE ACST032
MONTAGE ACST032
MONTAGE ACST032

WERKTEKENINGEN - DESSINS DE CONSTRUCTION - KONSTRUKTIONZEICHNUNGEN - CONSTRUCTION DRAWINGS

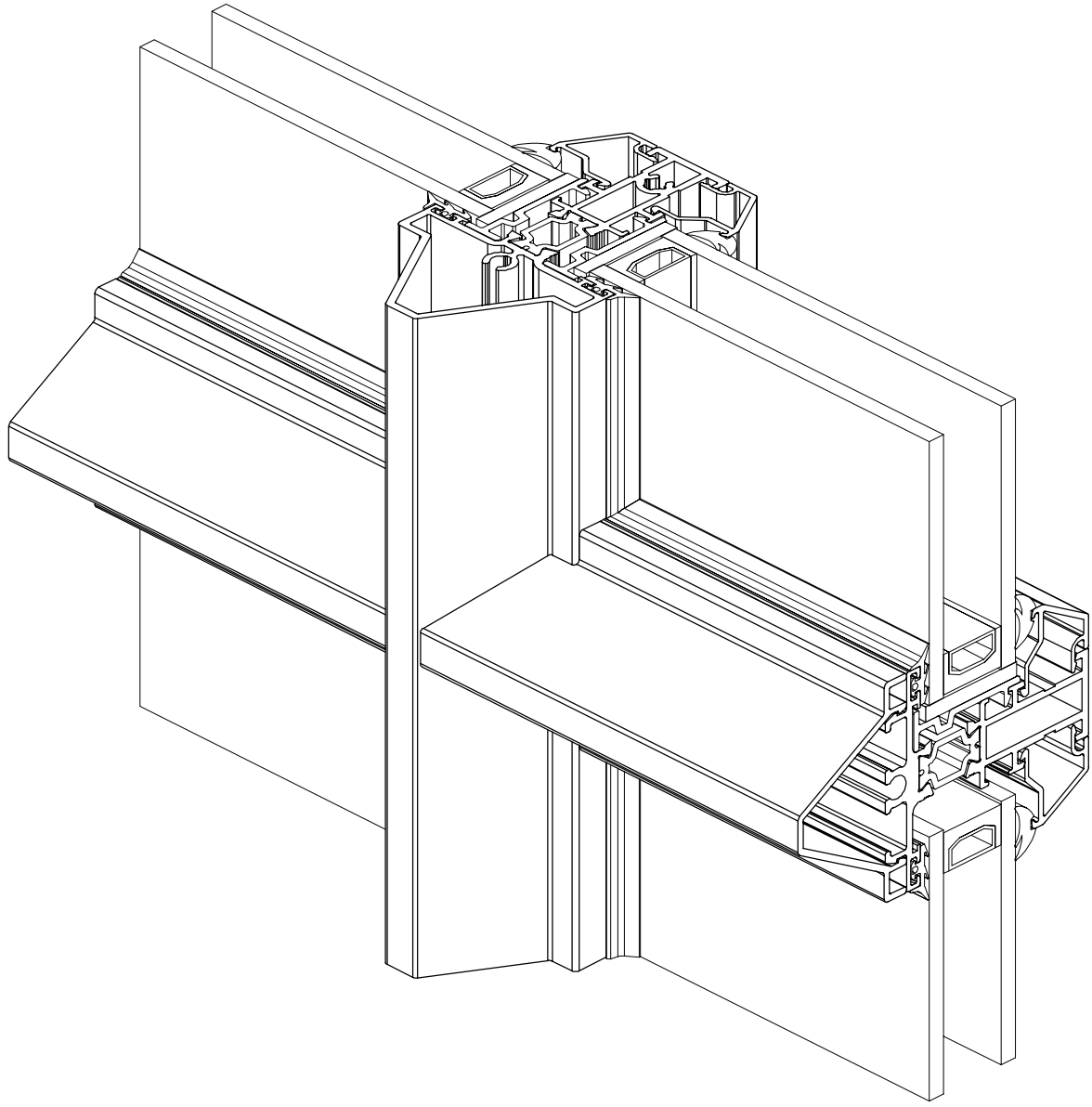
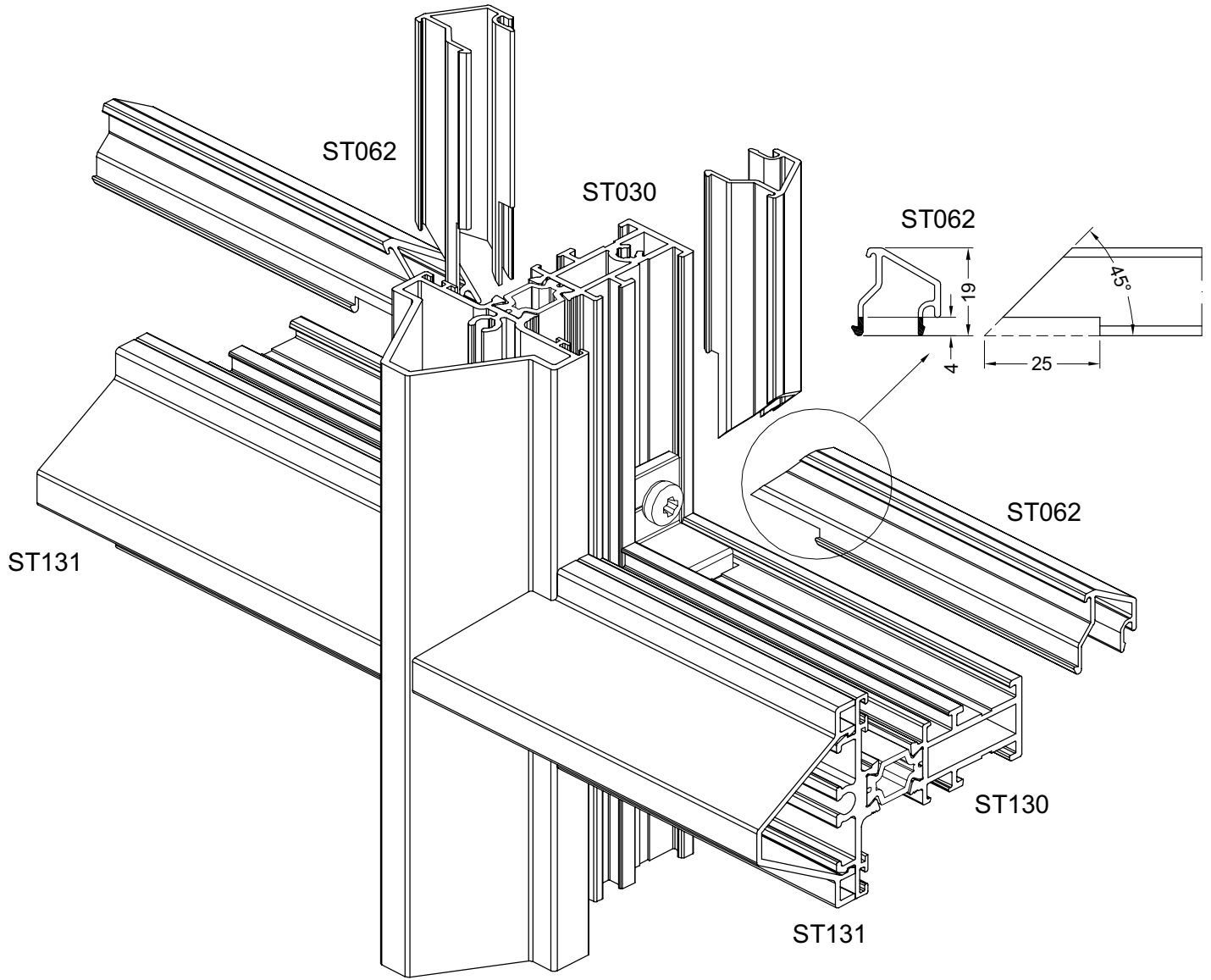

Tprof3

MONTAGE ACST030
MONTAGE ACST030
MONTAGE ACST030
MONTAGE ACST030

WERKTEKENINGEN - DESSINS DE CONSTRUCTION - KONSTRUKTIONZEICHNUNGEN - CONSTRUCTION DRAWINGS

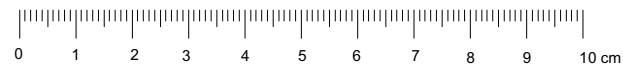
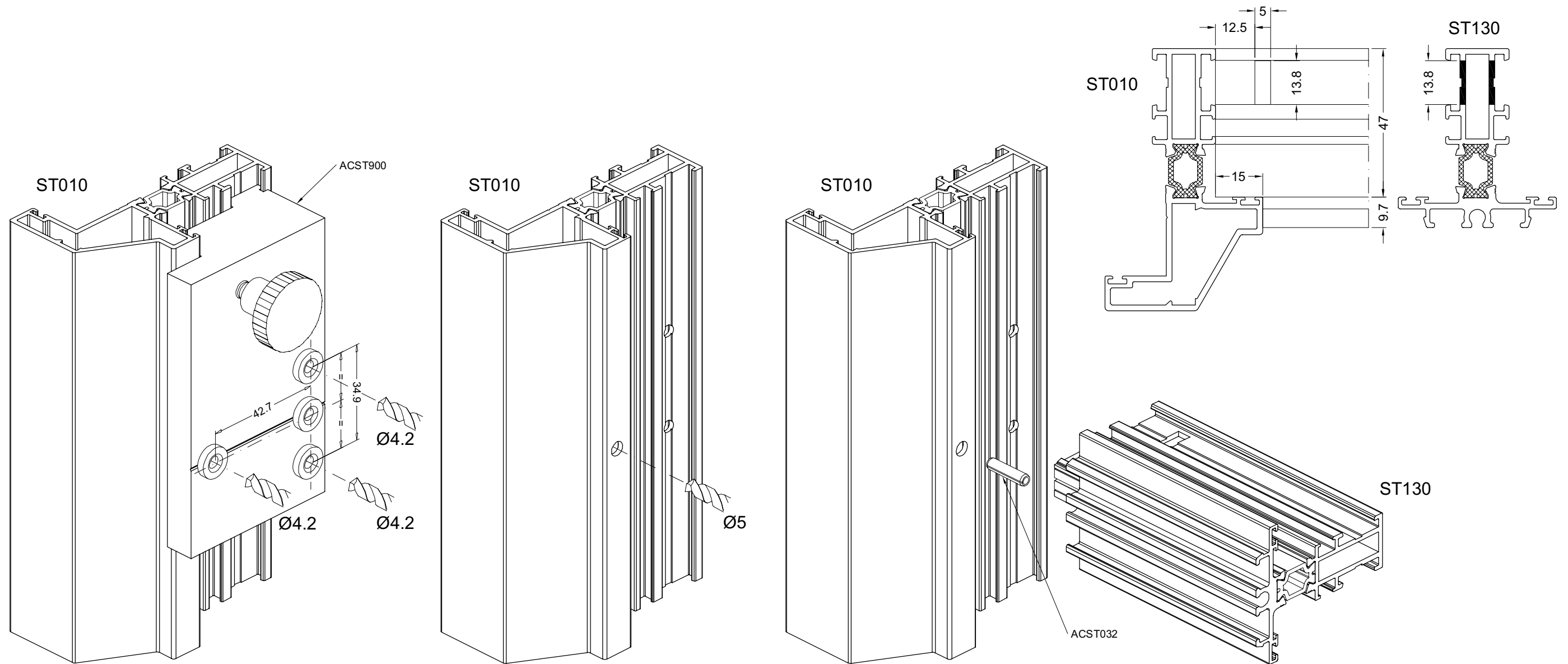

T-enk1

MONTAGE ACST030
MONTAGE ACST030
MONTAGE ACST030
MONTAGE ACST030

WERKTEKENINGEN - DESSINS DE CONSTRUCTION - KONSTRUKTIONZEICHNUNGEN - CONSTRUCTION DRAWINGS

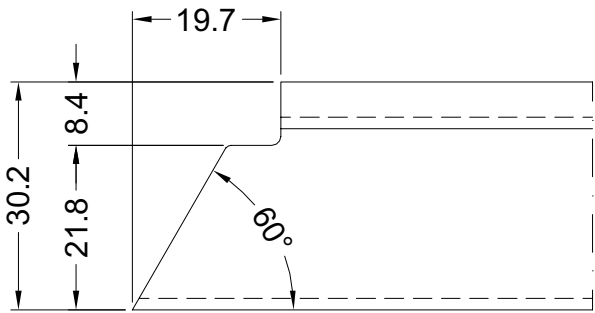
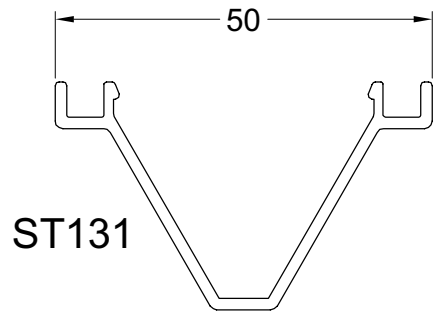
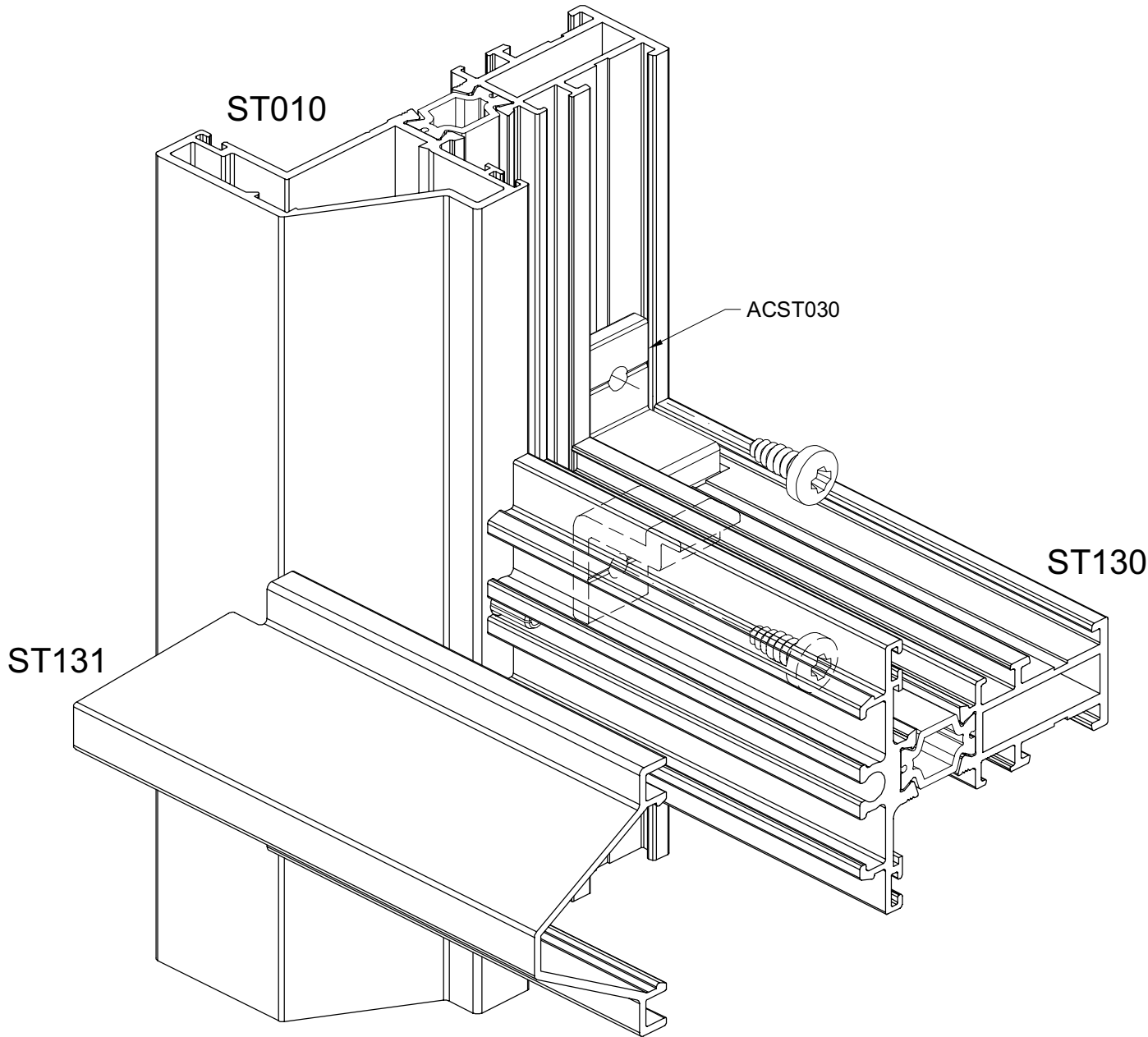
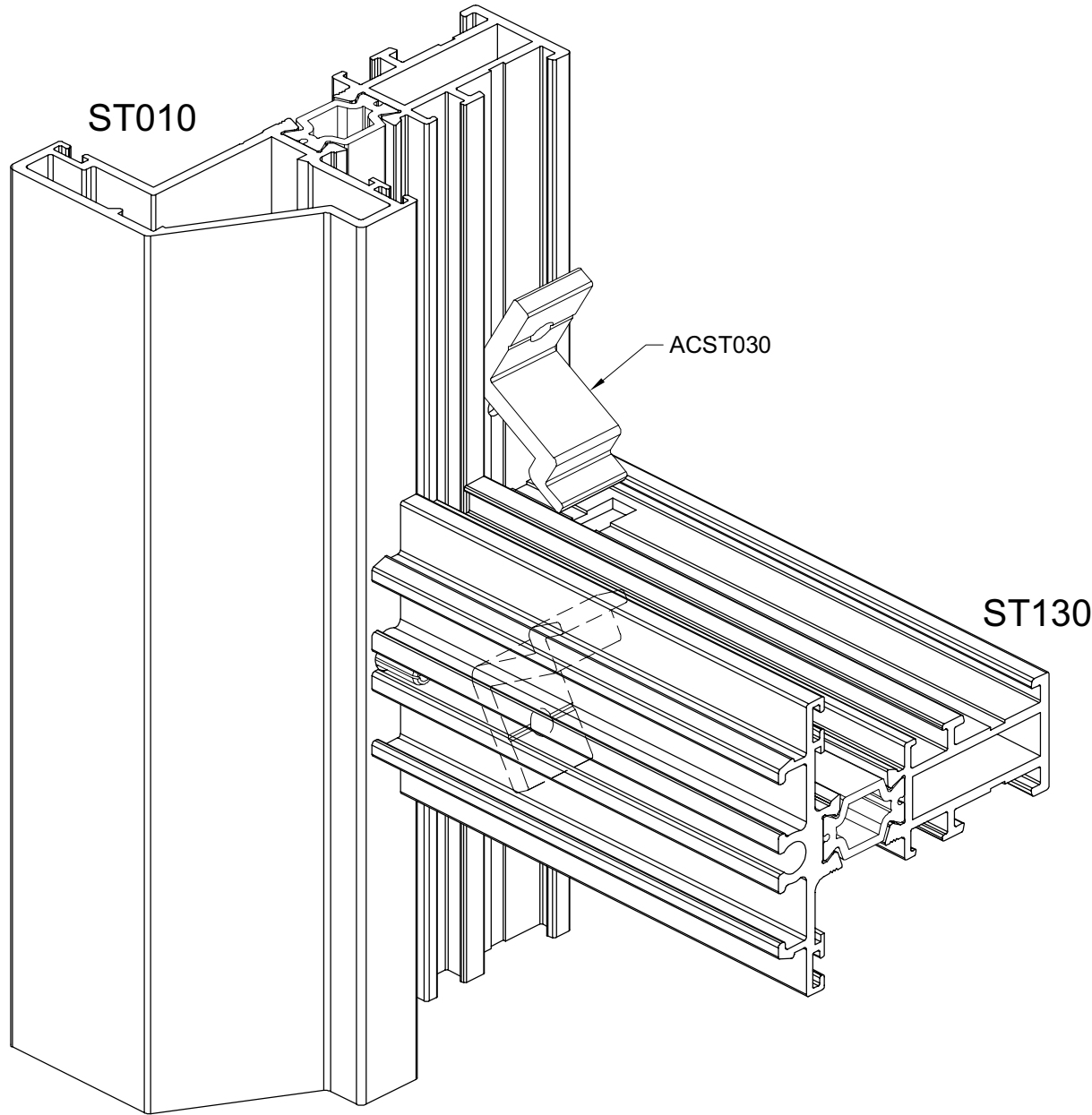

MONTAGE ACST030
MONTAGE ACST030
MONTAGE ACST030
MONTAGE ACST030

WERKTEKENINGEN - DESSINS DE CONSTRUCTION - KONSTRUKTIONZEICHNUNGEN - CONSTRUCTION DRAWINGS

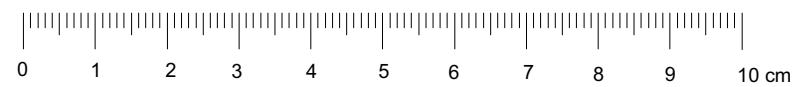
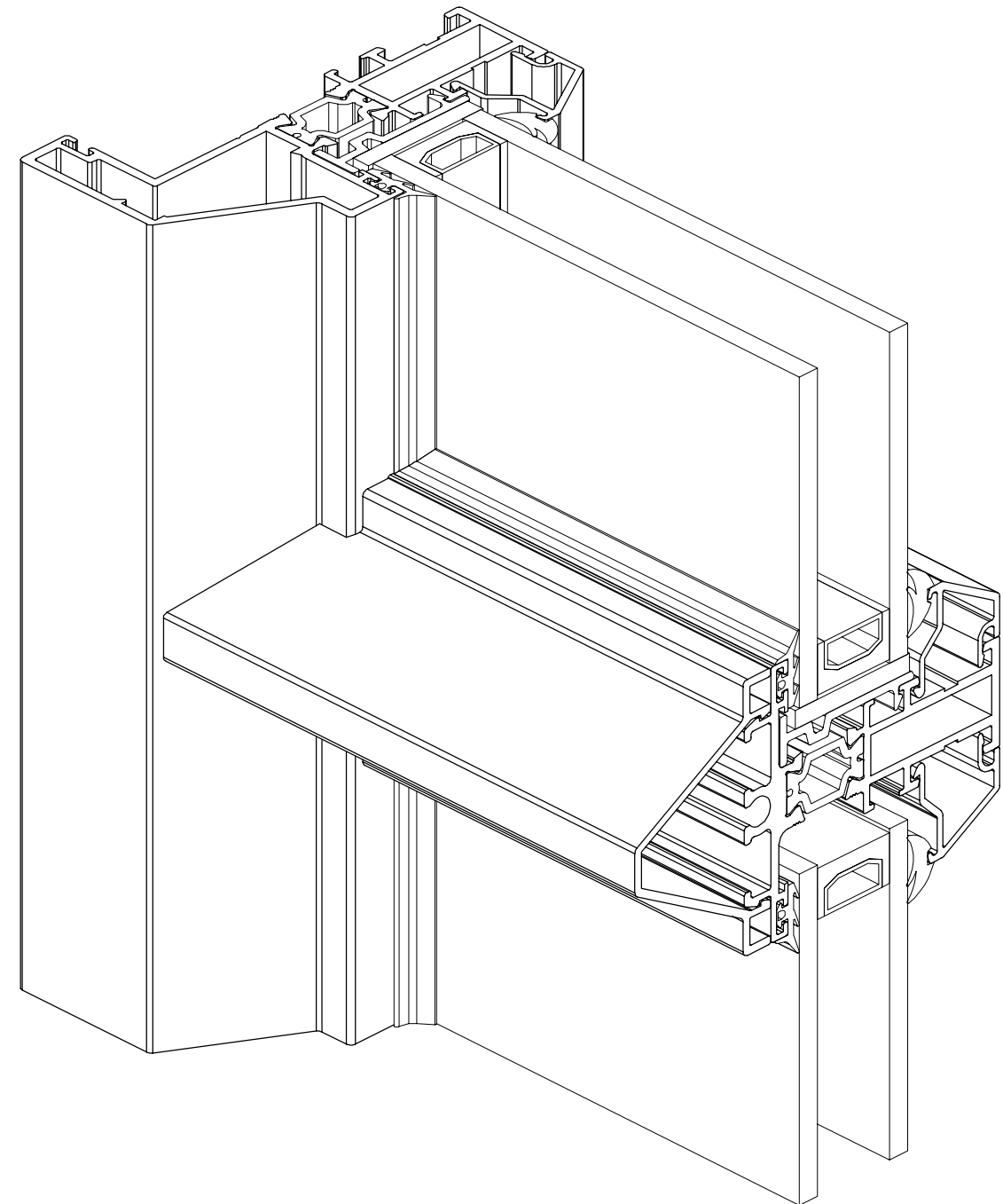
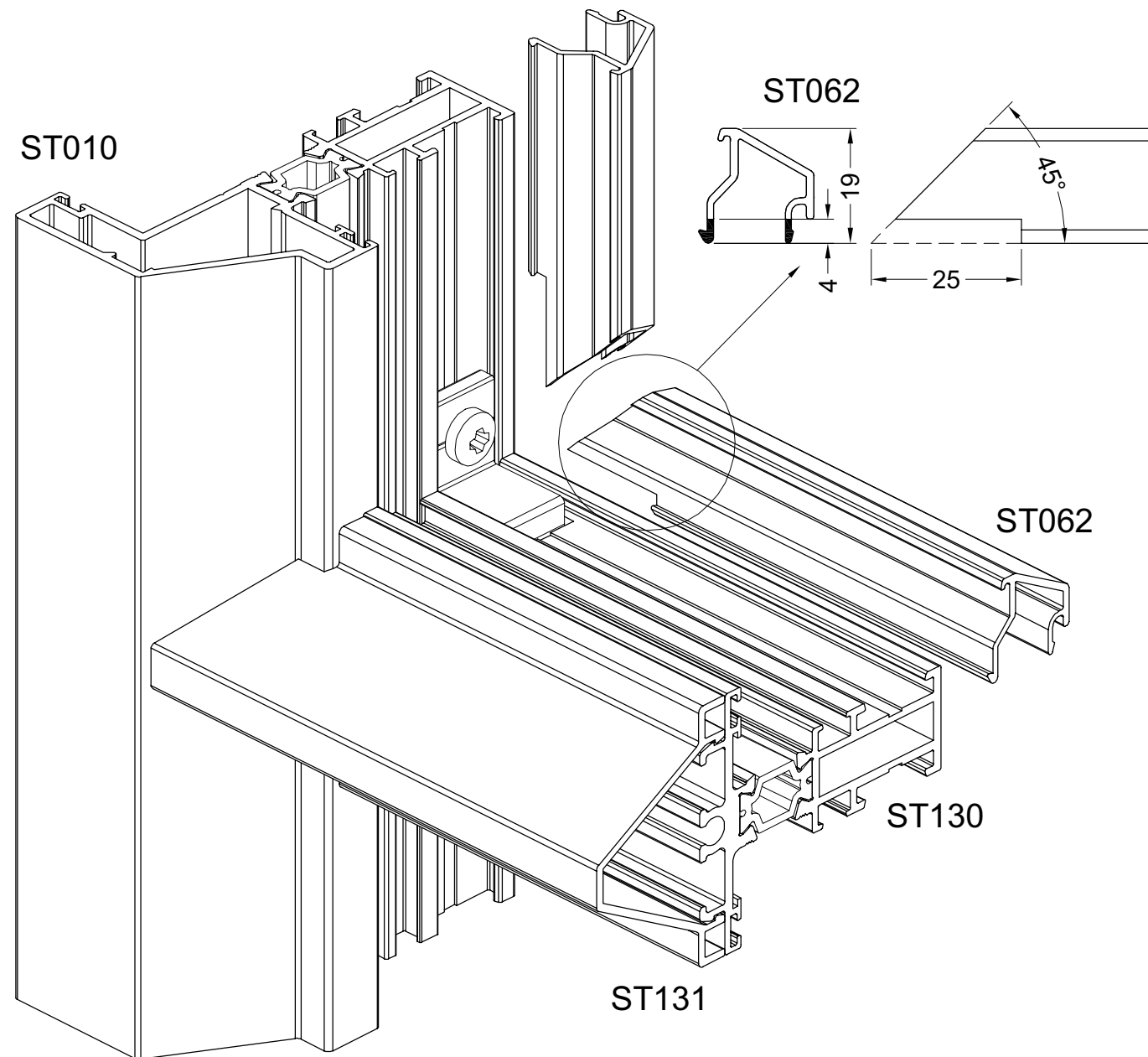

T-enk3

MONTAGE ACST025
MONTAGE ACST025
MONTAGE ACST025
MONTAGE ACST025

WERKTEKENINGEN - DESSINS DE CONSTRUCTION - KONSTRUKTIONZEICHNUNGEN - CONSTRUCTION DRAWINGS

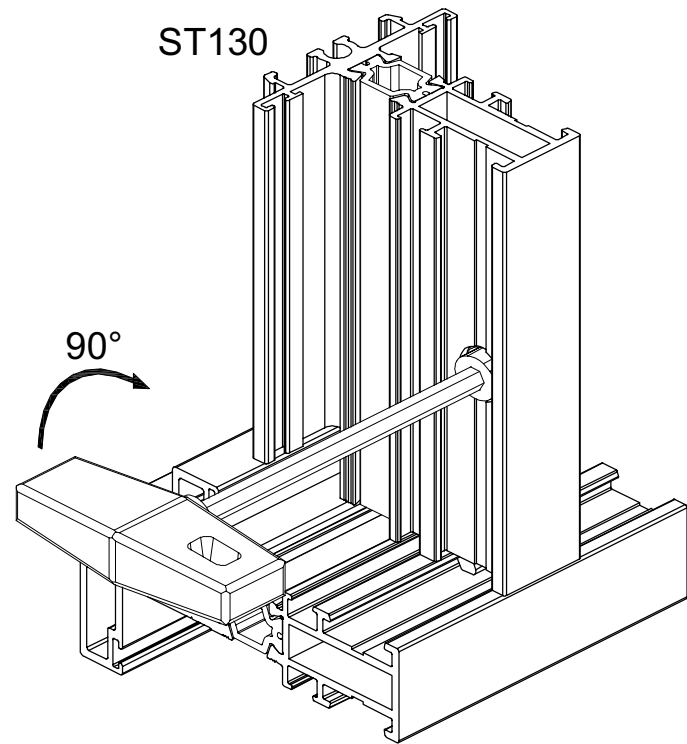
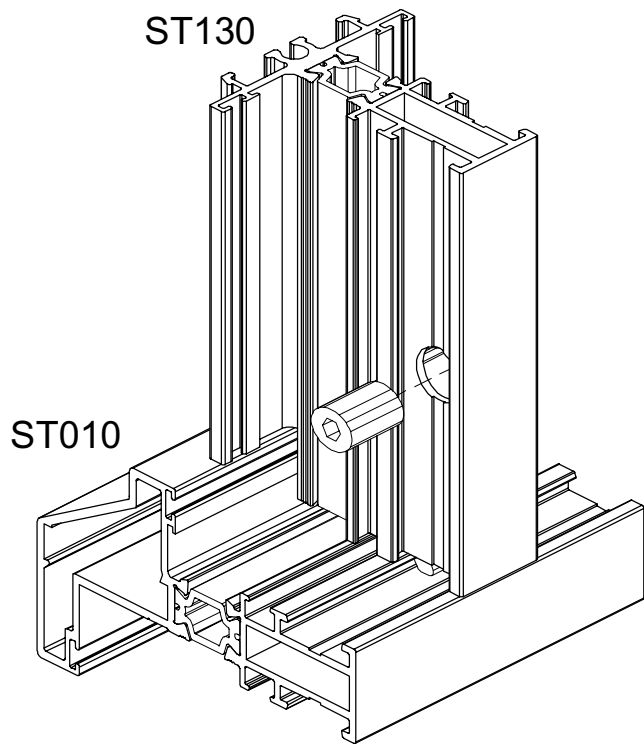
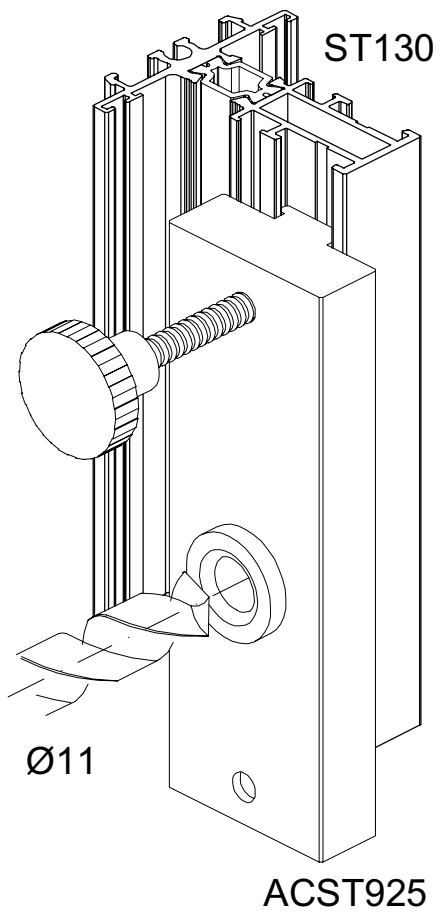
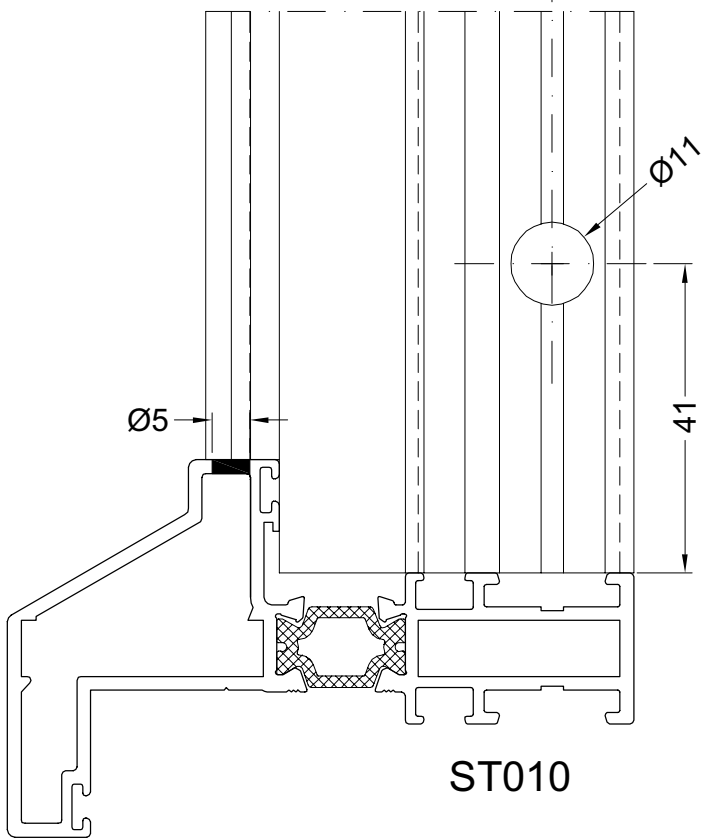
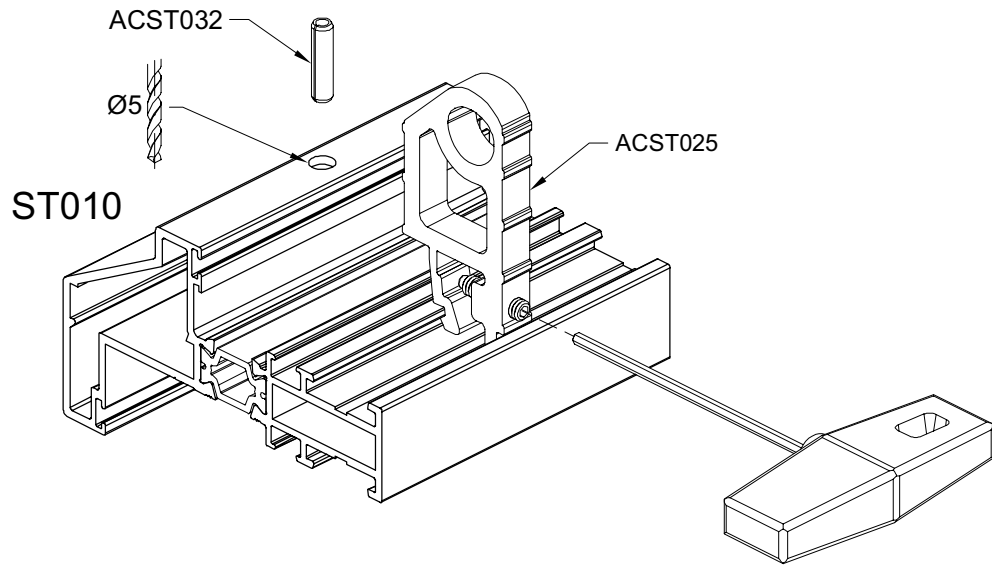
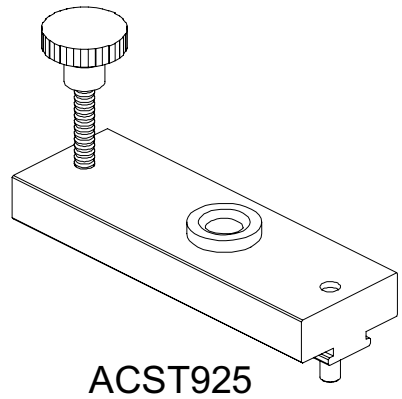
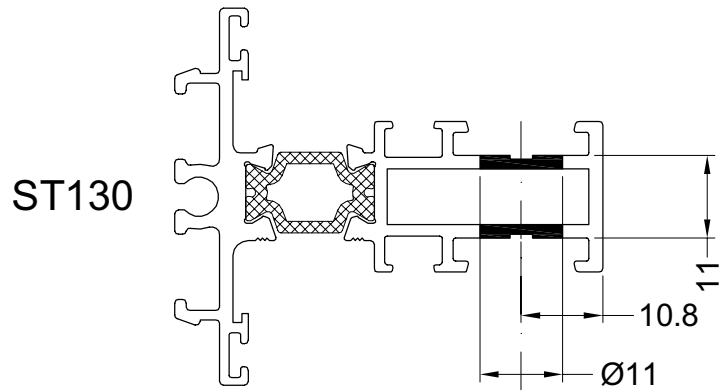

monacst025

MONTAGE VERDOKEN SCHARNIER ACUN040
MONTAGE PAUMELLE CACHE ACUN040
MONTAGE VERBORGEN BAND ACUN040
MONTAGE HIDDEN HINGE ACUN040

WERKTEKENINGEN - DESSINS DE CONSTRUCTION - KONSTRUKTIONZEICHNUNGEN - CONSTRUCTION DRAWINGS

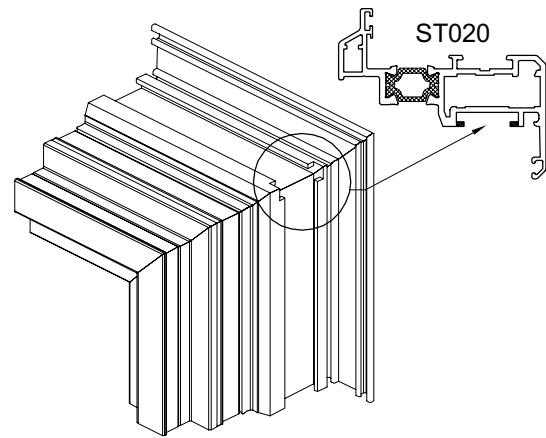

Maximaal vleugelgewicht
Poids max du vantail
Maximales Flügelgewicht
Max. weight sash

80kg

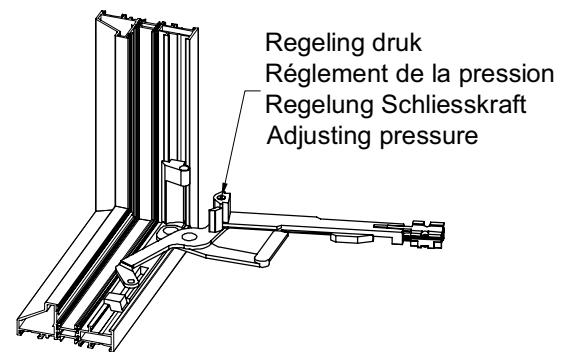

Regeling druk
Réglement de la pression
Regelung Schliesskraft
Adjusting pressure

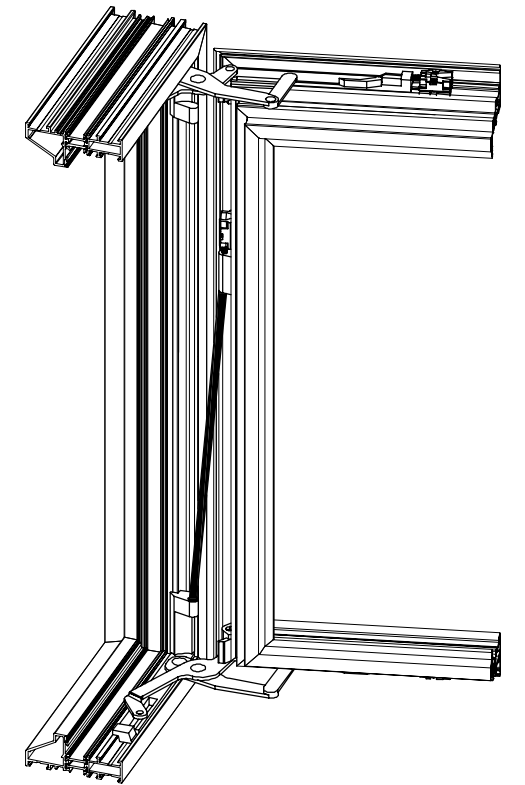
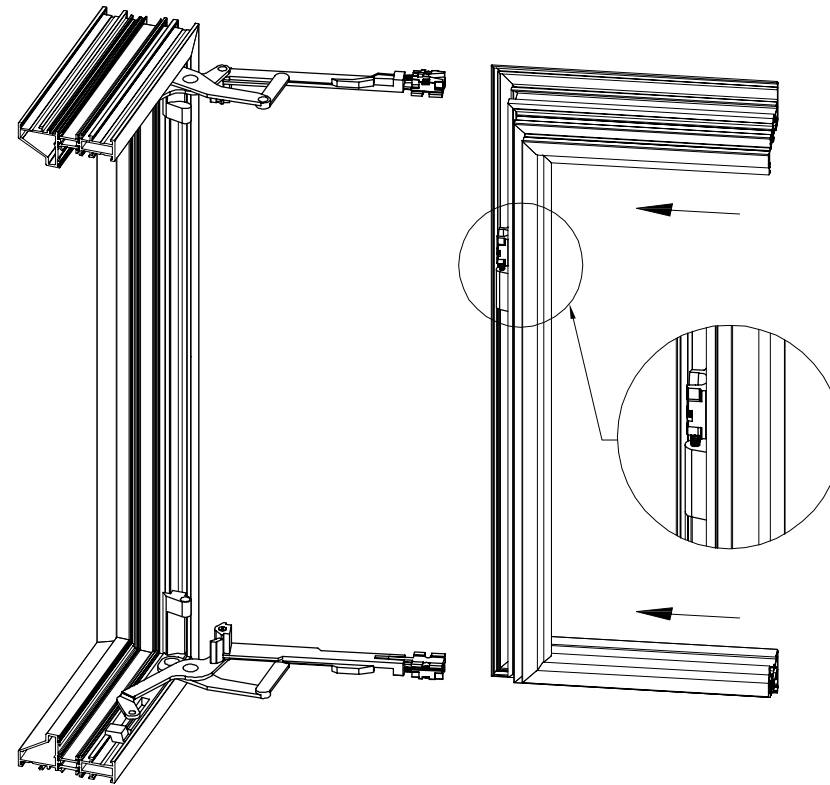

ACUN042

Extra sluitpunt
Point de verrouillage supplémentaire
Mittelverschluss
Supplementary locking point

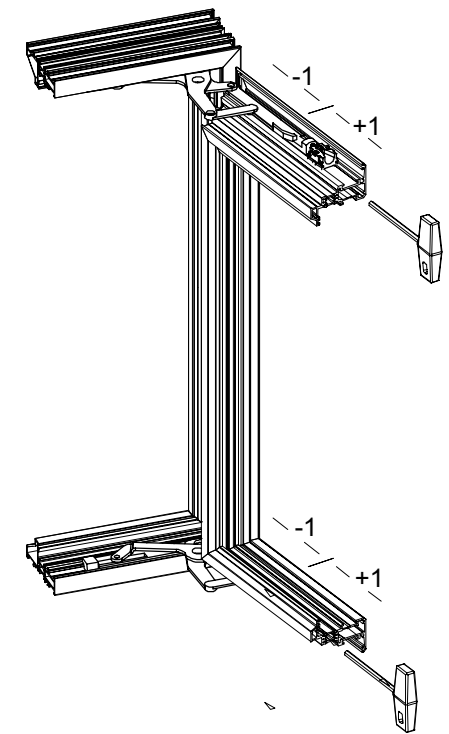
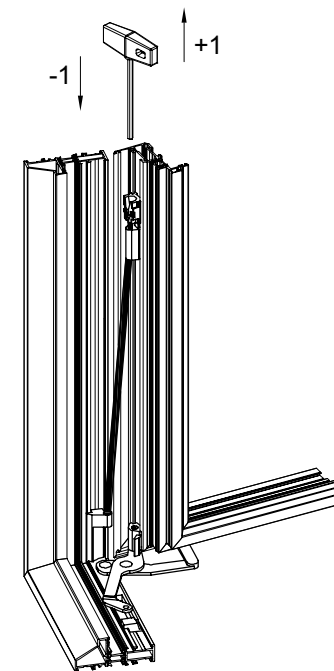
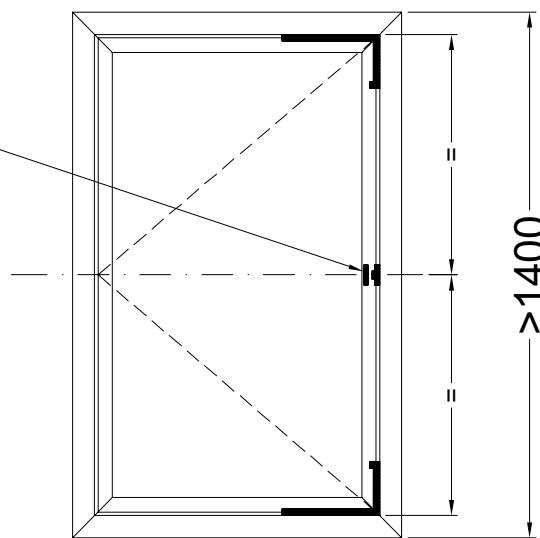
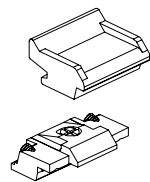

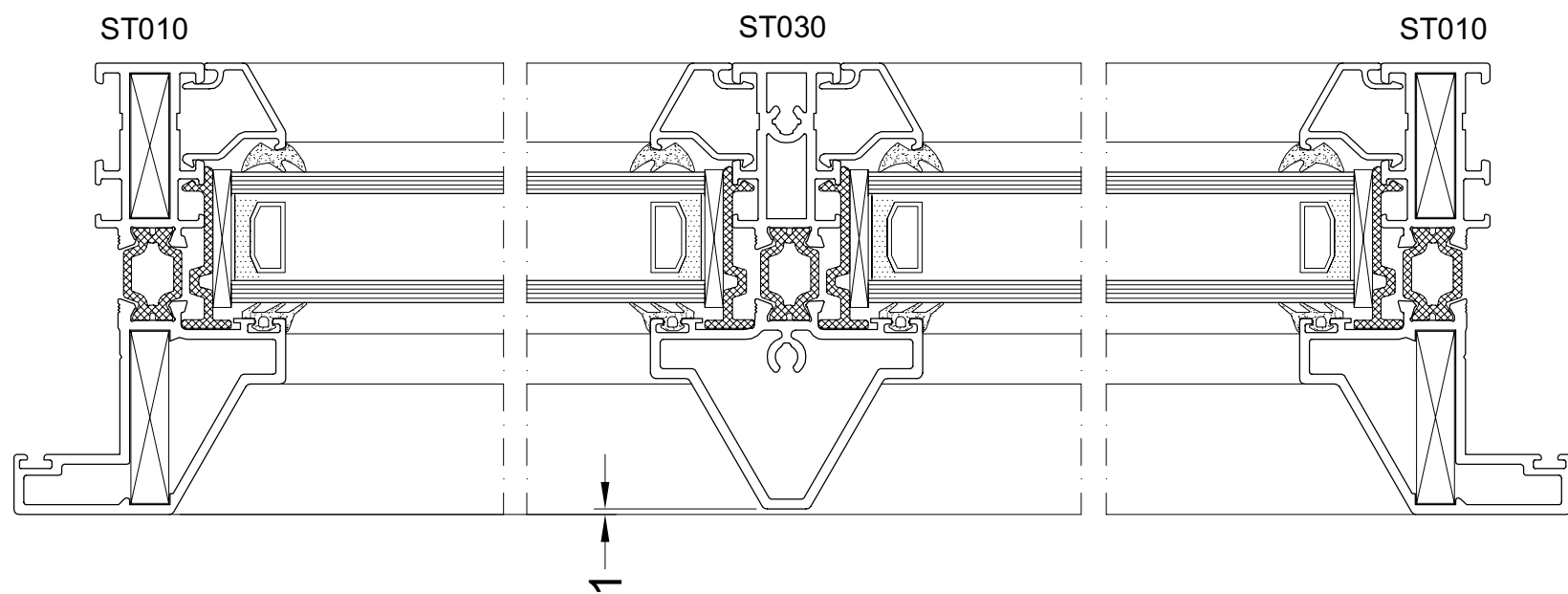
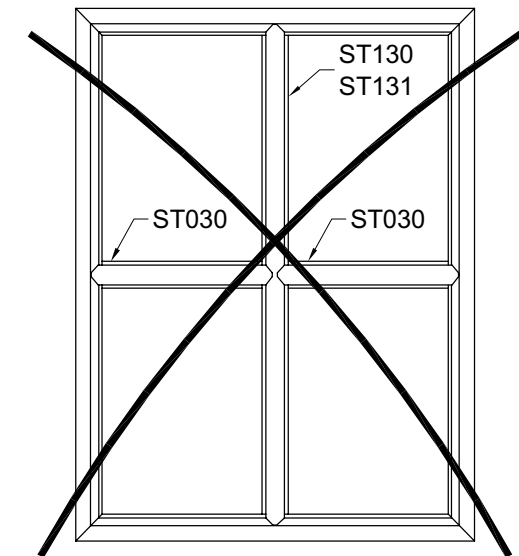
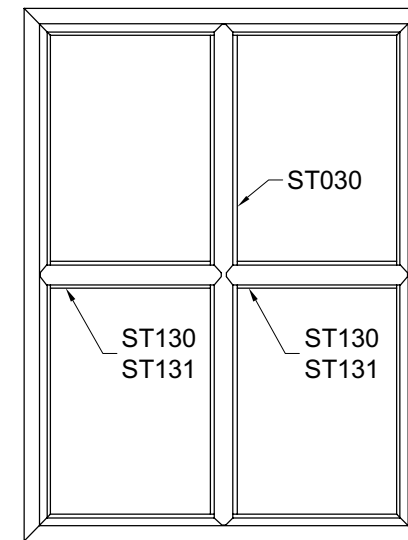
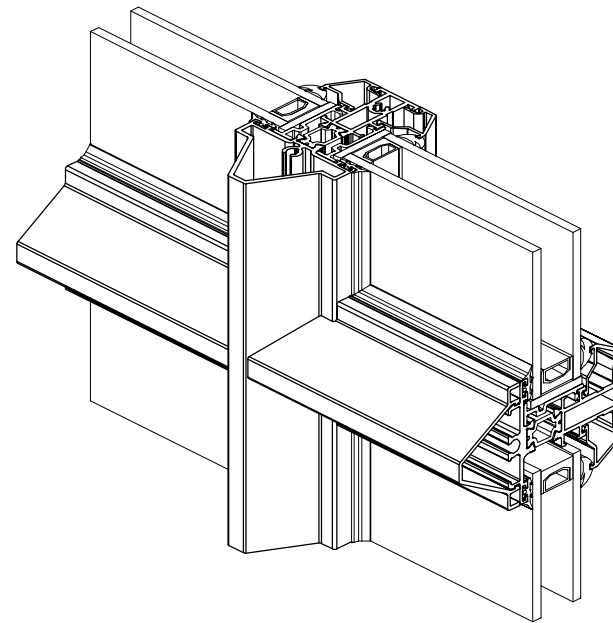
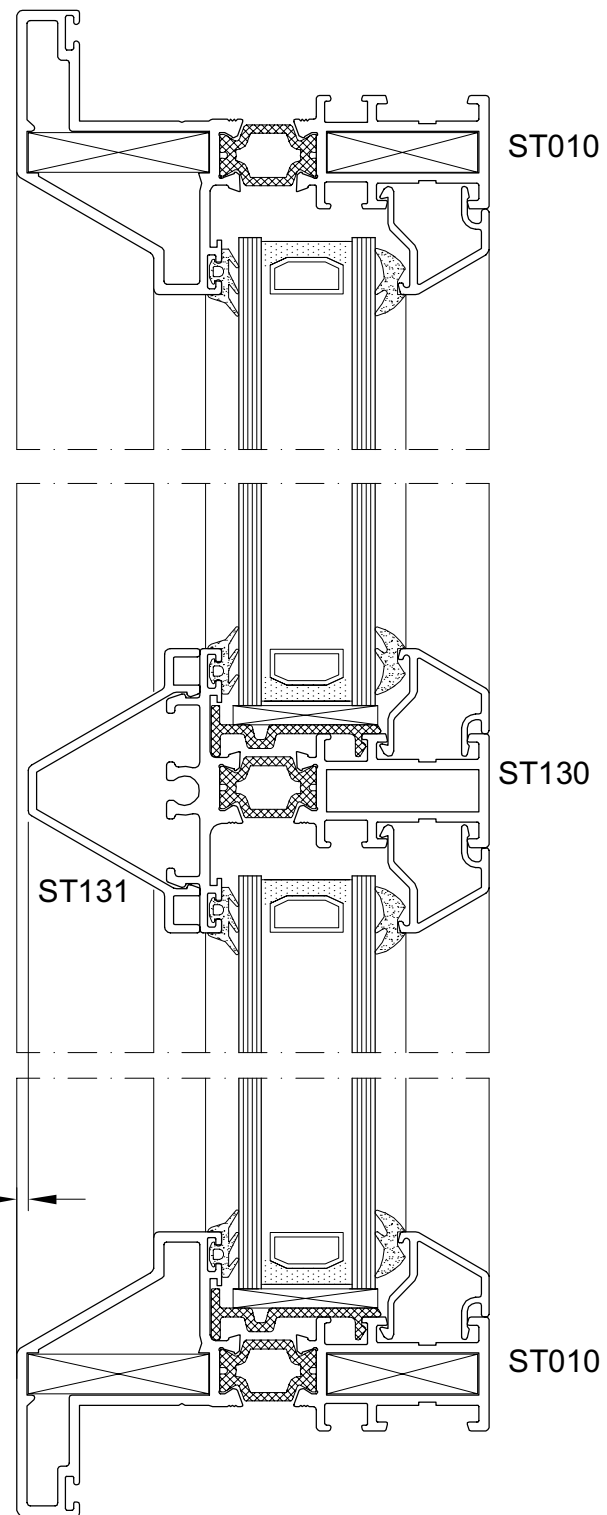

travers

MOGELIJKHEDEN VLEUGELS
POSSIBILITES OUVRANTS
MOGLICHKEITEN FLUGELPROFILE
POSSIBILITIES VENTS

WERKTEKENINGEN - DESSINS DE CONSTRUCTION - KONSTRUKTIONZEICHNUNGEN - CONSTRUCTION DRAWINGS

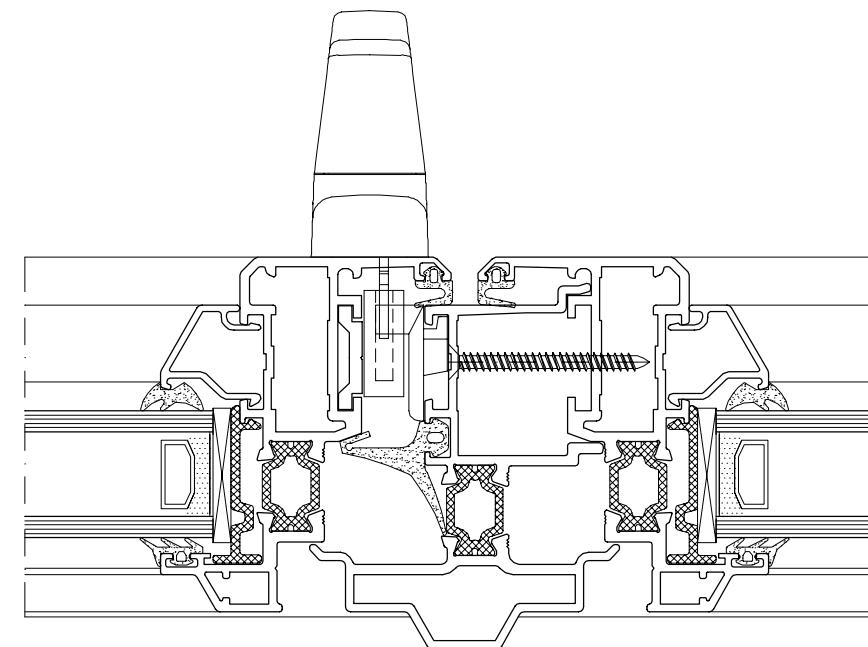
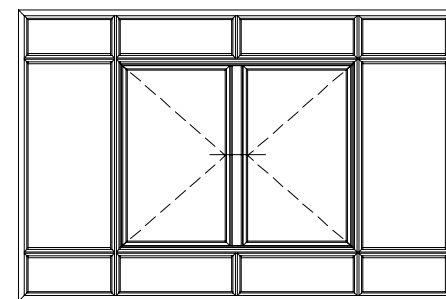
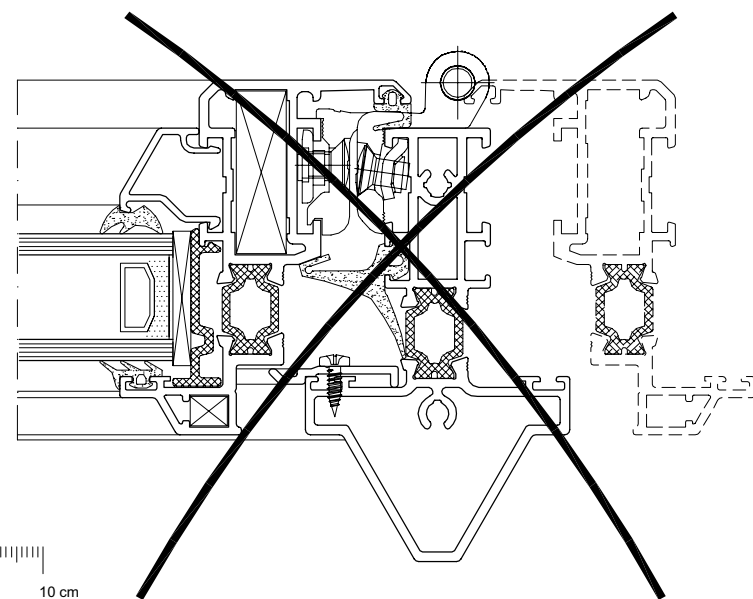
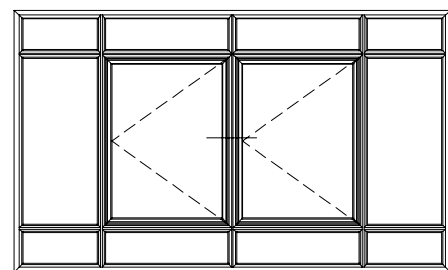
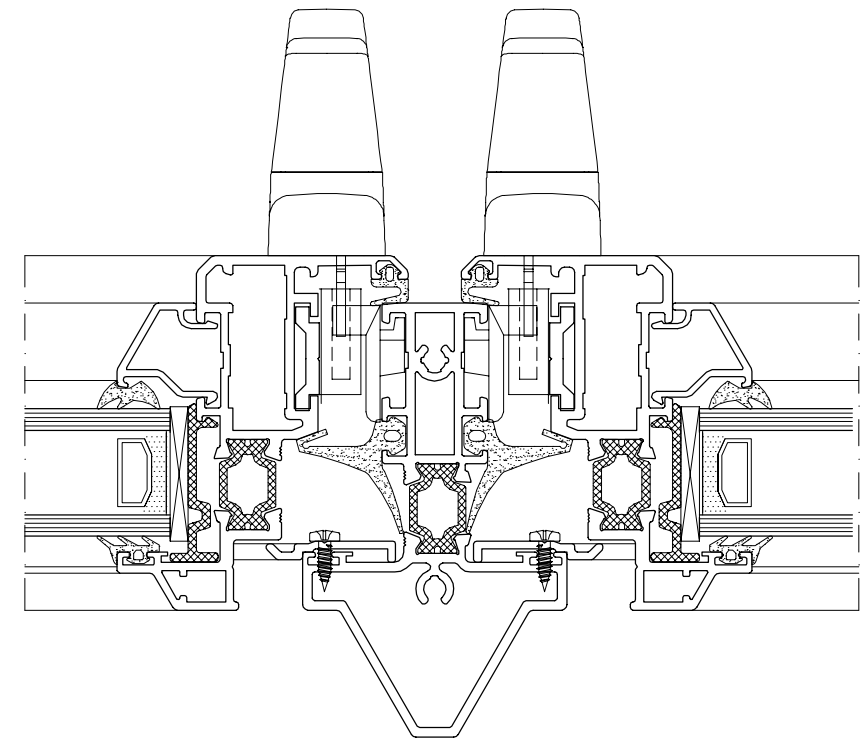
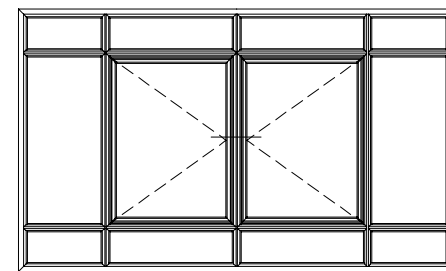
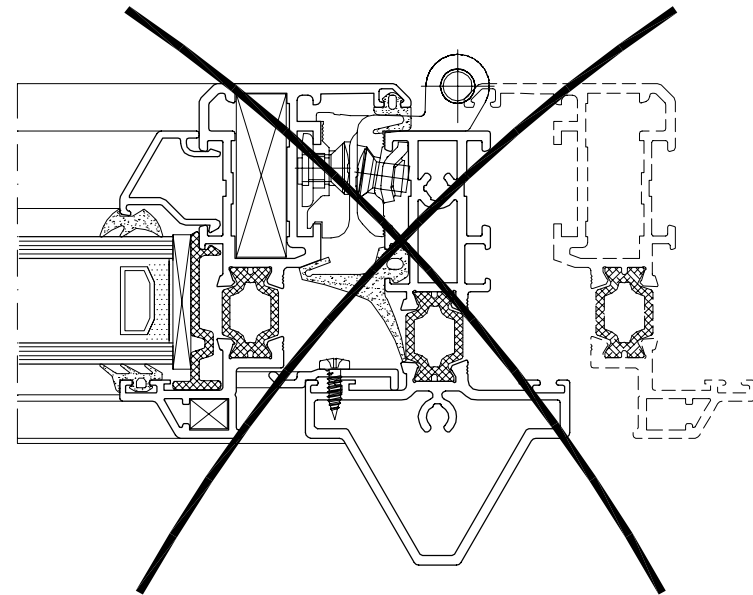
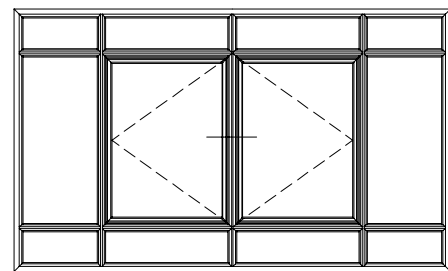

overzicht

MONTAGE ACST054
MONTAGE ACST054
MONTAGE ACST054
MONTAGE ACST054

WERKTEKENINGEN - DESSINS DE CONSTRUCTION - KONSTRUKTIONZEICHNUNGEN - CONSTRUCTION DRAWINGS

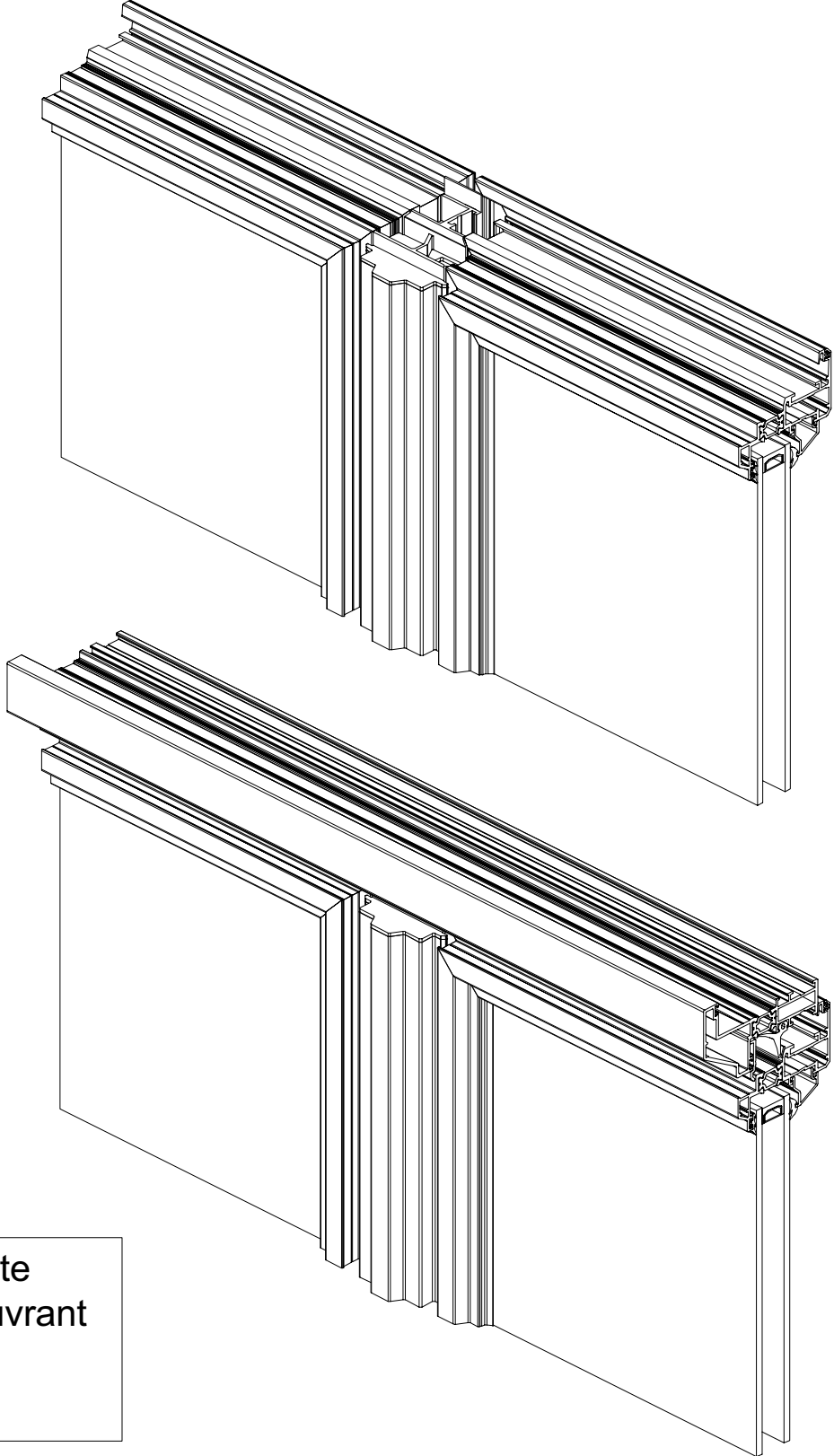
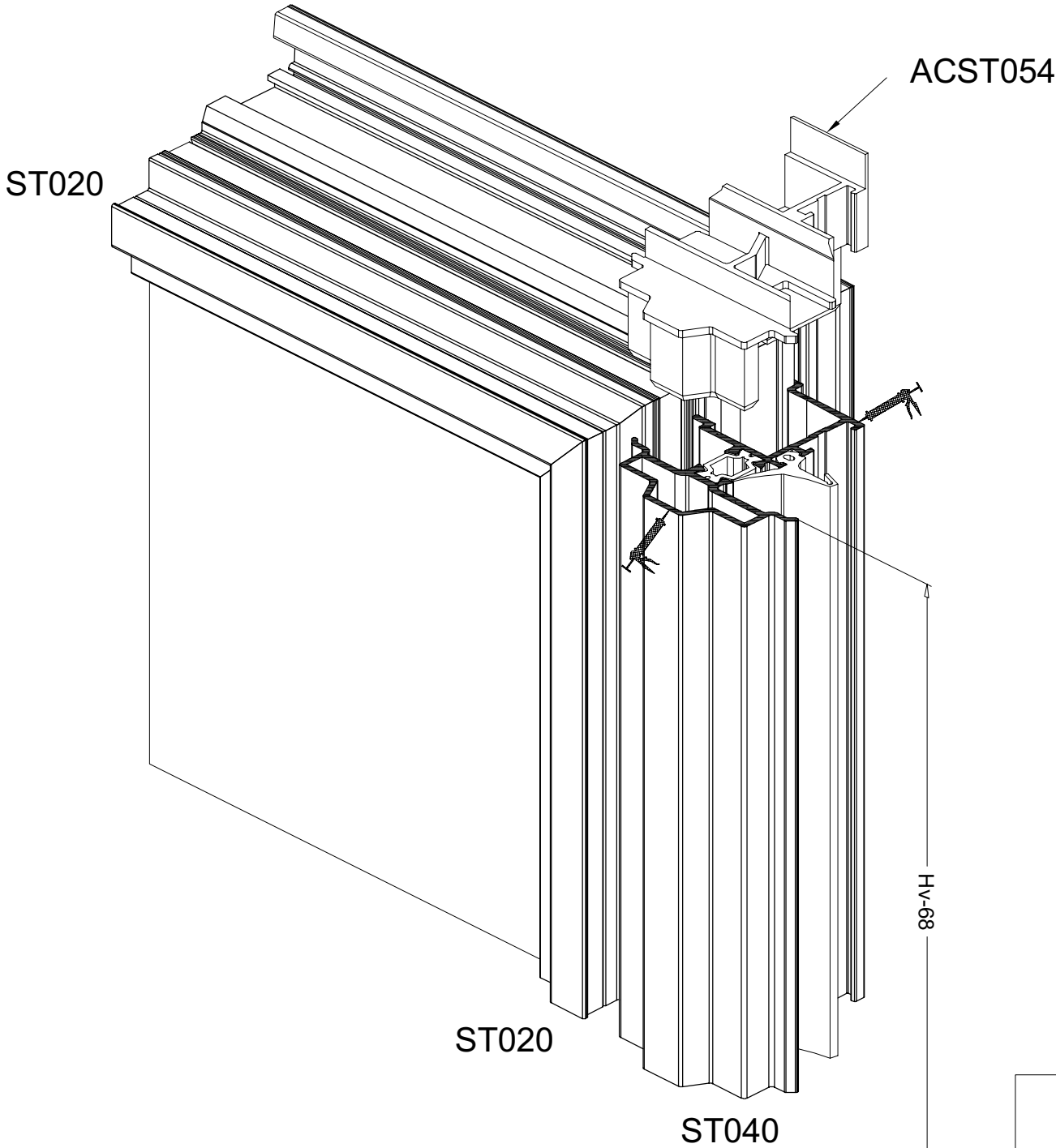

HV= Vleugelhoogte
Hauteur d'ouvrant
Flügel hohe
Vent height

MONTAGE ACST154
MONTAGE ACST154
MONTAGE ACST154
MONTAGE ACST154

WERKTEKENINGEN - DESSINS DE CONSTRUCTION - KONSTRUKTIONZEICHNUNGEN - CONSTRUCTION DRAWINGS

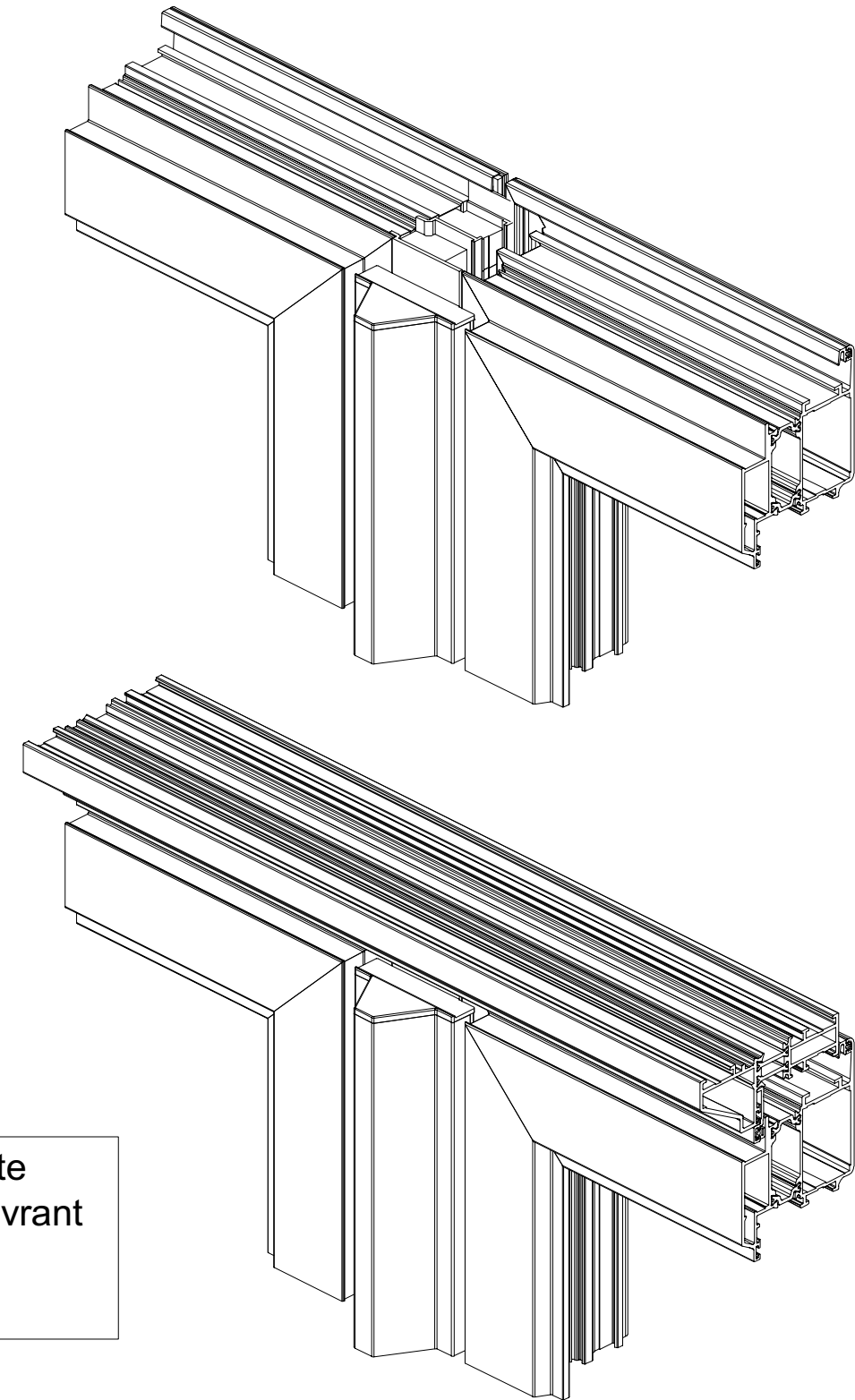
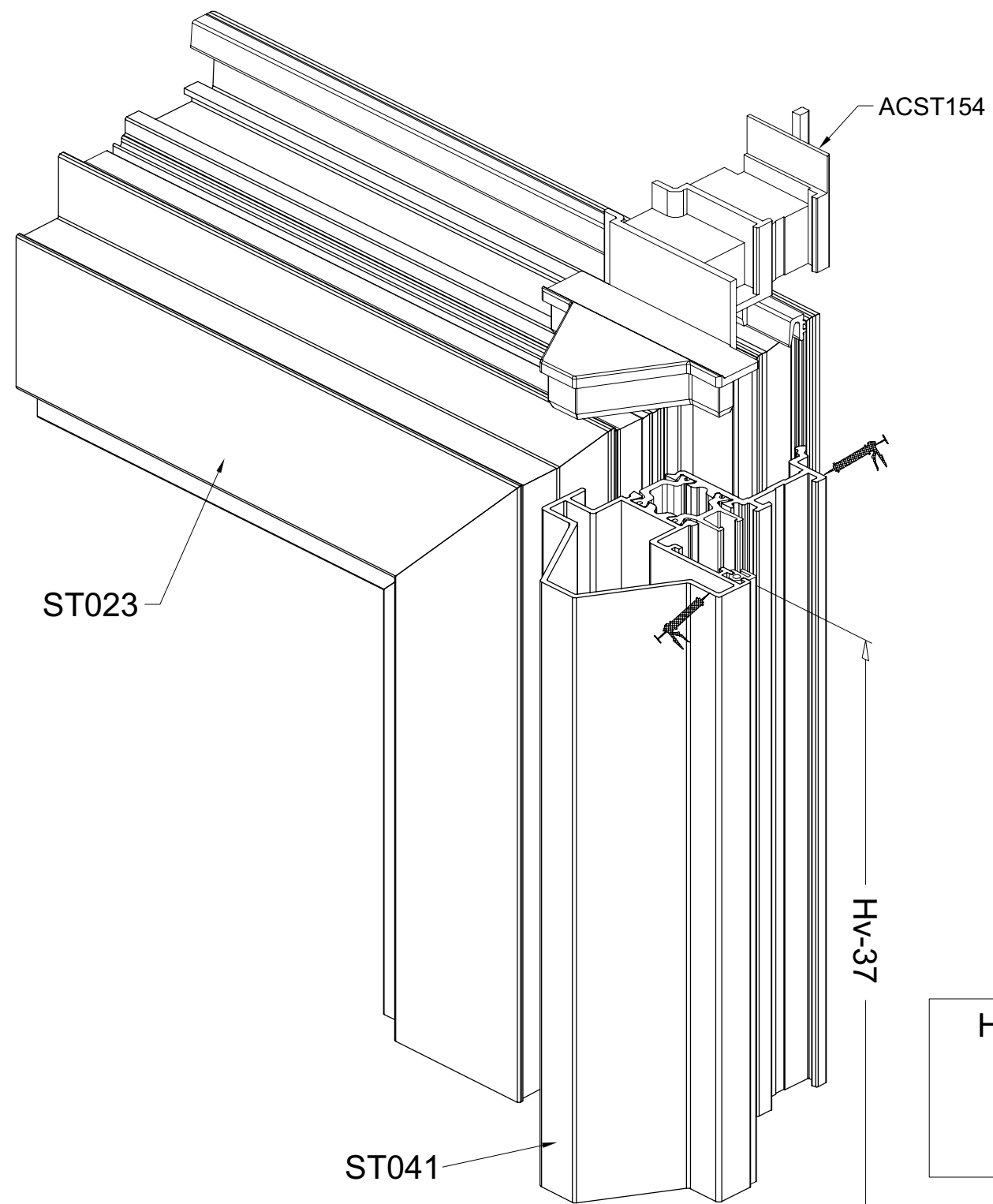

HV= Vleugelhoogte
Hauteur d'ouvrant
Flugel hohe
Vent height

MONTAGE BOORMAL VOOR WATERGAT
MONTAGE CALIBRE POUR EVACUATION D'EAU
MONTAGE BOHRSCABLONE FUR ENTWASSERUNG
MONTAGE BORING JIG SET FOR DRAIN HOLE

WERKTEKENINGEN - DESSINS DE CONSTRUCTION - KONSTRUKTIONZEICHNUNGEN - CONSTRUCTION DRAWINGS

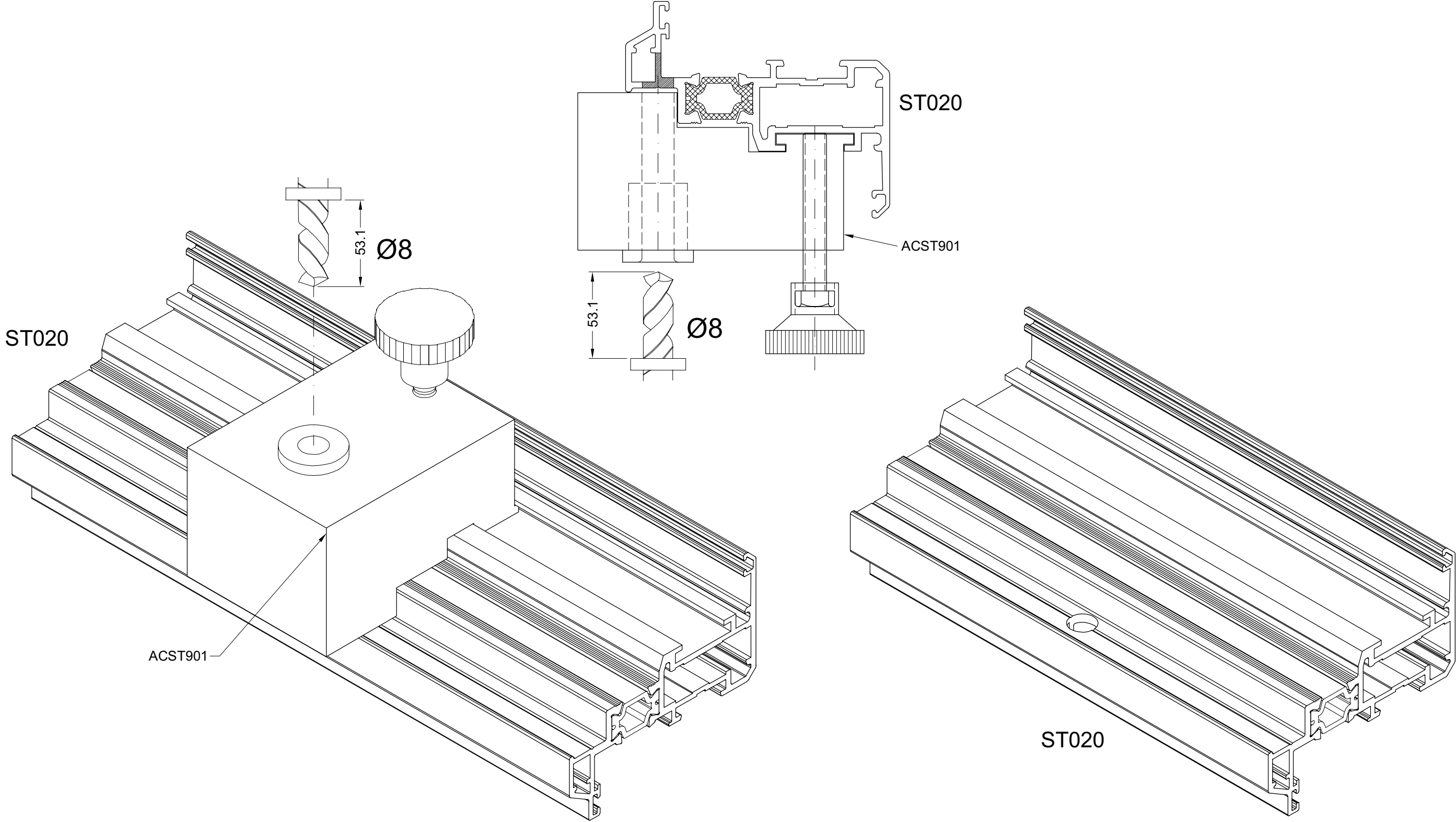

acst901

MONTAGE SLOT IN ST110-ST023
MONTAGE SERRURE DANS ST110-ST023
MONTAGE SCHLOSSER IN ST110-ST023
MONTAGE LOCK IN ST110-ST023

WERKTEKENINGEN - DESSINS DE CONSTRUCTION - KONSTRUKTIONZEICHNUNGEN - CONSTRUCTION DRAWINGS

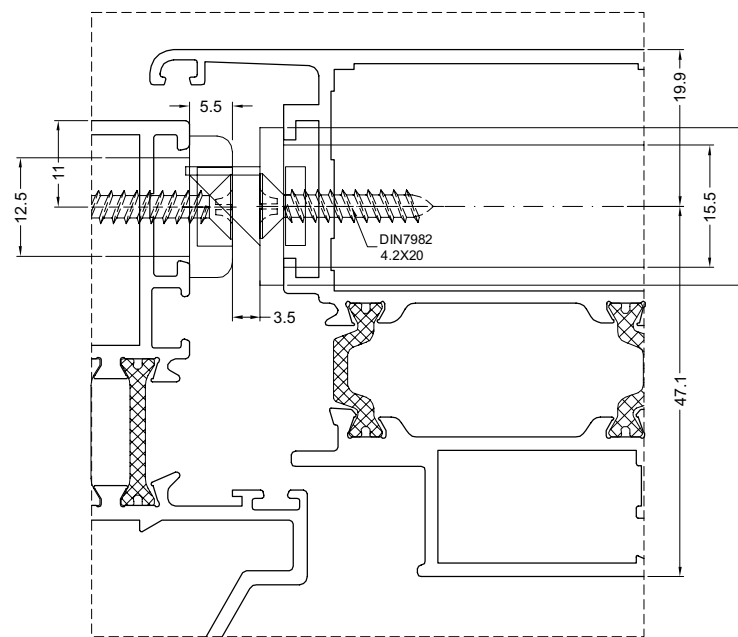
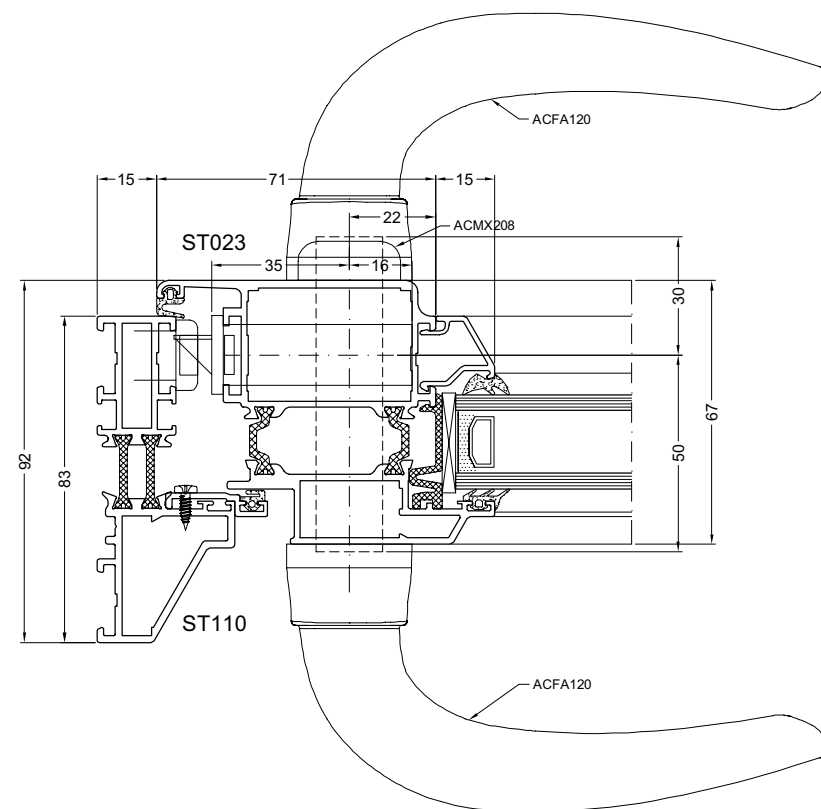

TOEPASSING	ACVL705 ACVL707	
APPLICATION		
ANWENDUNG		
APPLICATION		

DEUR PORTE TUR DOOR	Penslot Serrure à pêne Schloss mit Falle Lock with pen		Rolslot Serrure à rouleau Schloss mit rolle Lock with roll	
	1-punt 1-point 1-Punkt 1-Point	3-punt 3-points 3-Punkt 3-Points	1-punt 1-point 1-Punkt 1-Point	3-punt 3-points 3-Punkt 3-Points
Binnendraaiend Ouvrant vers l'intérieur Innen öffnend Inside opening	ACVL705	ACVL707	ACVL706	ACVL708

Cilinderplaatje Cache cylindre Zylinder-rosette Cover for cylinder	Cilinder Cylindre Zylinder Cylinder	Cilinder 1/2 Cylindre 1/2 Zylinder 1/2 Cylinder 1/2
ACMX208 1x	ACVL117	ACMX01601

UITSPARING VOOR SLOT ACVL705, ACVL706, ACVL707, ACVL708
 ENTAILLE POUR SERRURES ACVL705, ACVL706, ACVL707, ACVL708
 EINBAU FÜR SCHLOSSER ACVL705, ACVL706, ACVL707, ACVL708
 ENBEDDING FOR LOCK ACVL705, ACVL706, ACVL707, ACVL708

WERKTEKENINGEN - DESSINS DE CONSTRUCTION - KONSTRUKTIONZEICHNUNGEN - CONSTRUCTION DRAWINGS

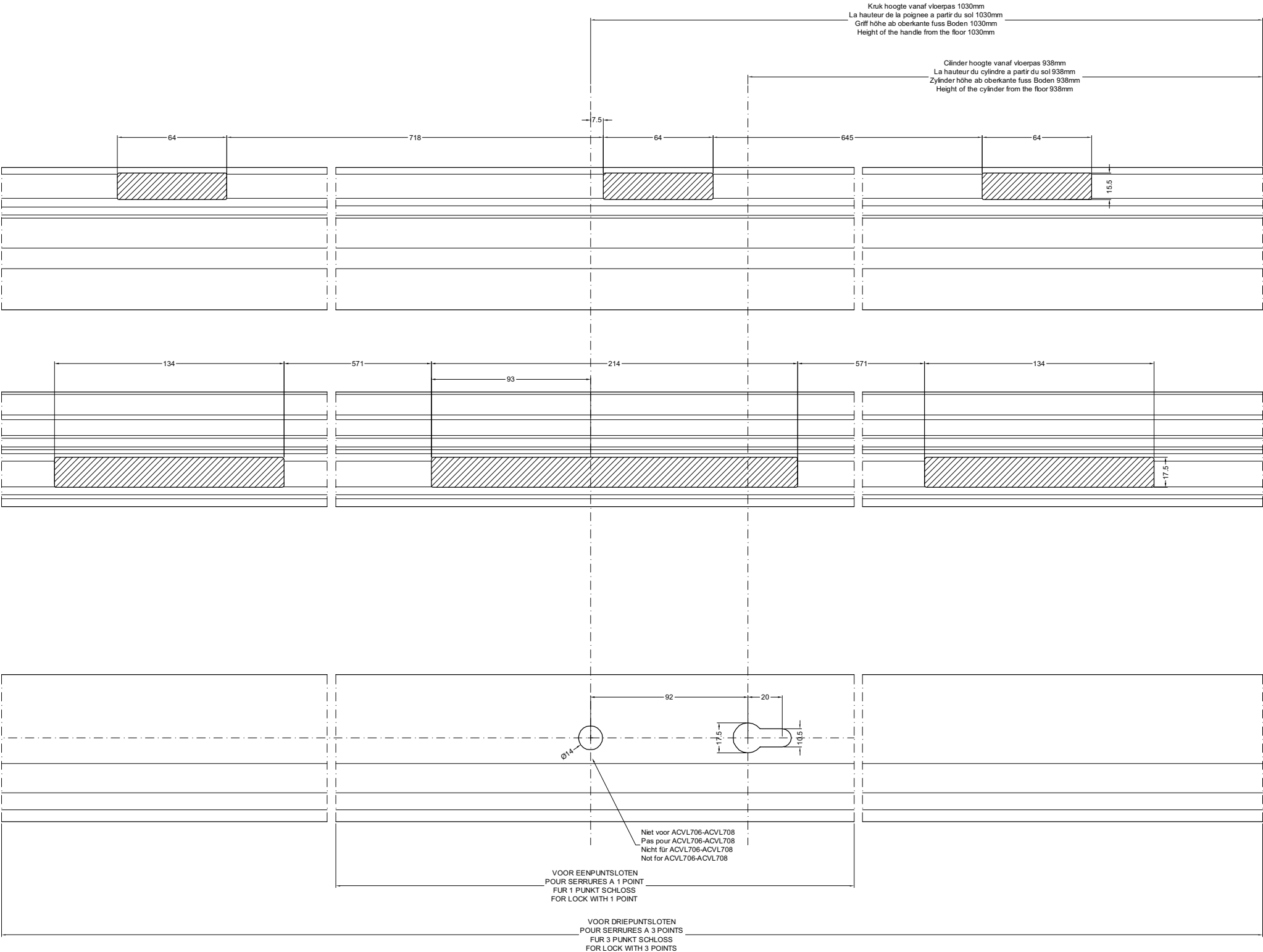
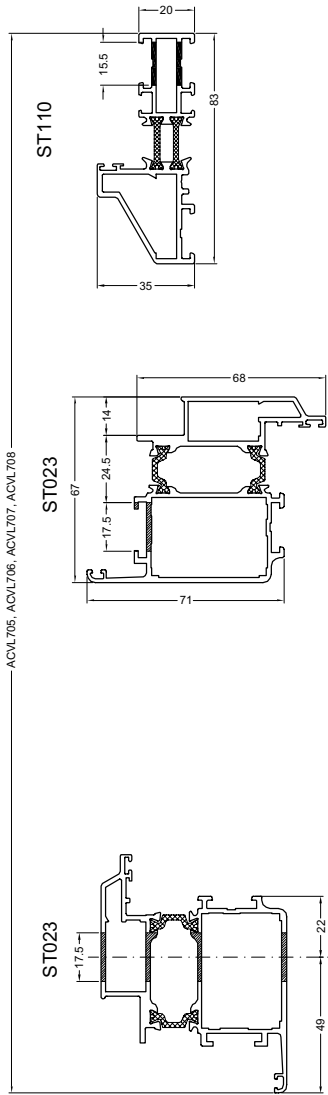

slot2

STEEL LOOK + VICTORIAN

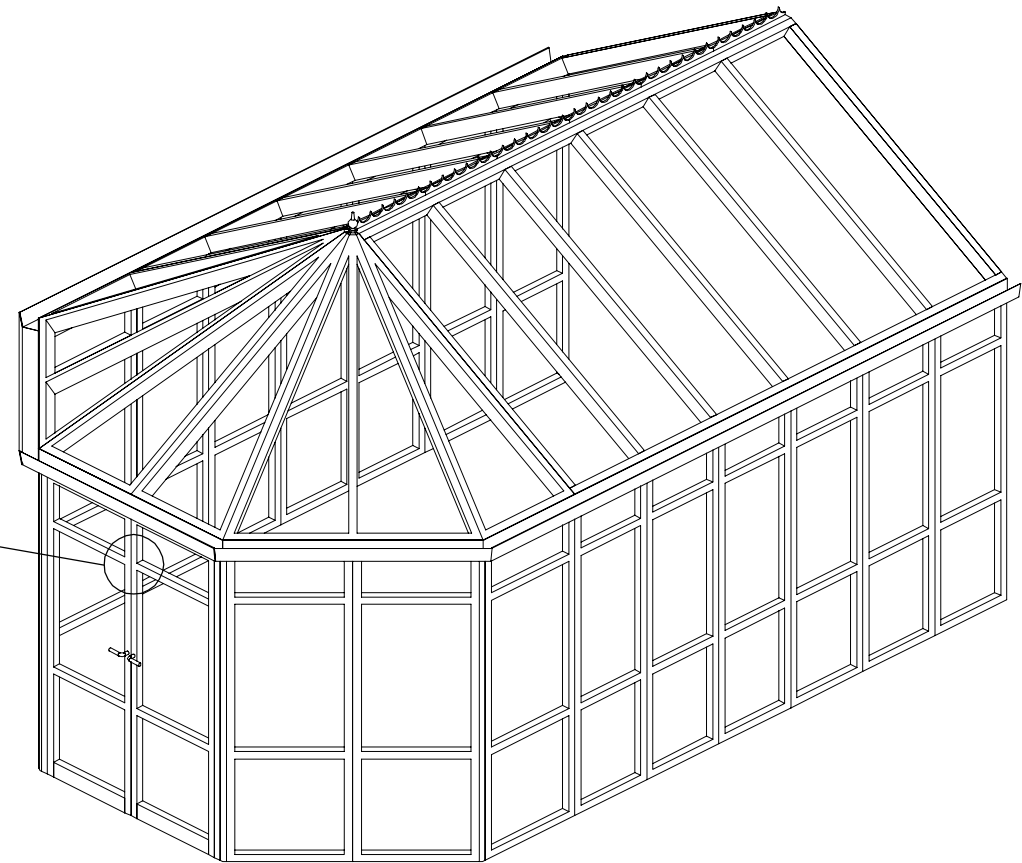
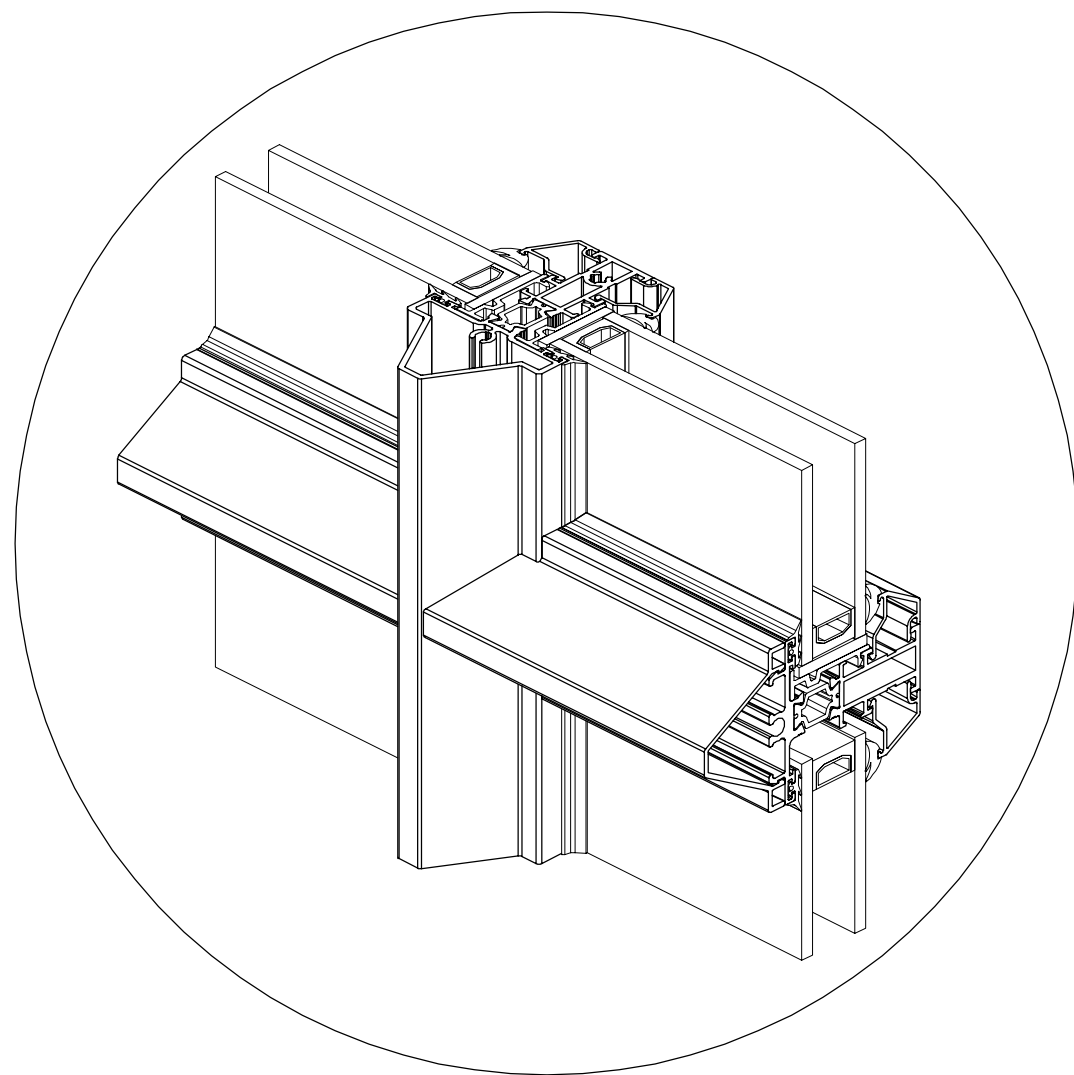

MONTAGE ST-VICTORIAN
MONTAGE ST-VICTORIAN
MONTAGE ST-VICTORIAN
MONTAGE ST-VICTORIAN

WERKTEKENINGEN - DESSINS DE CONSTRUCTION - KONSTRUKTIONZEICHNUNGEN - CONSTRUCTION DRAWINGS

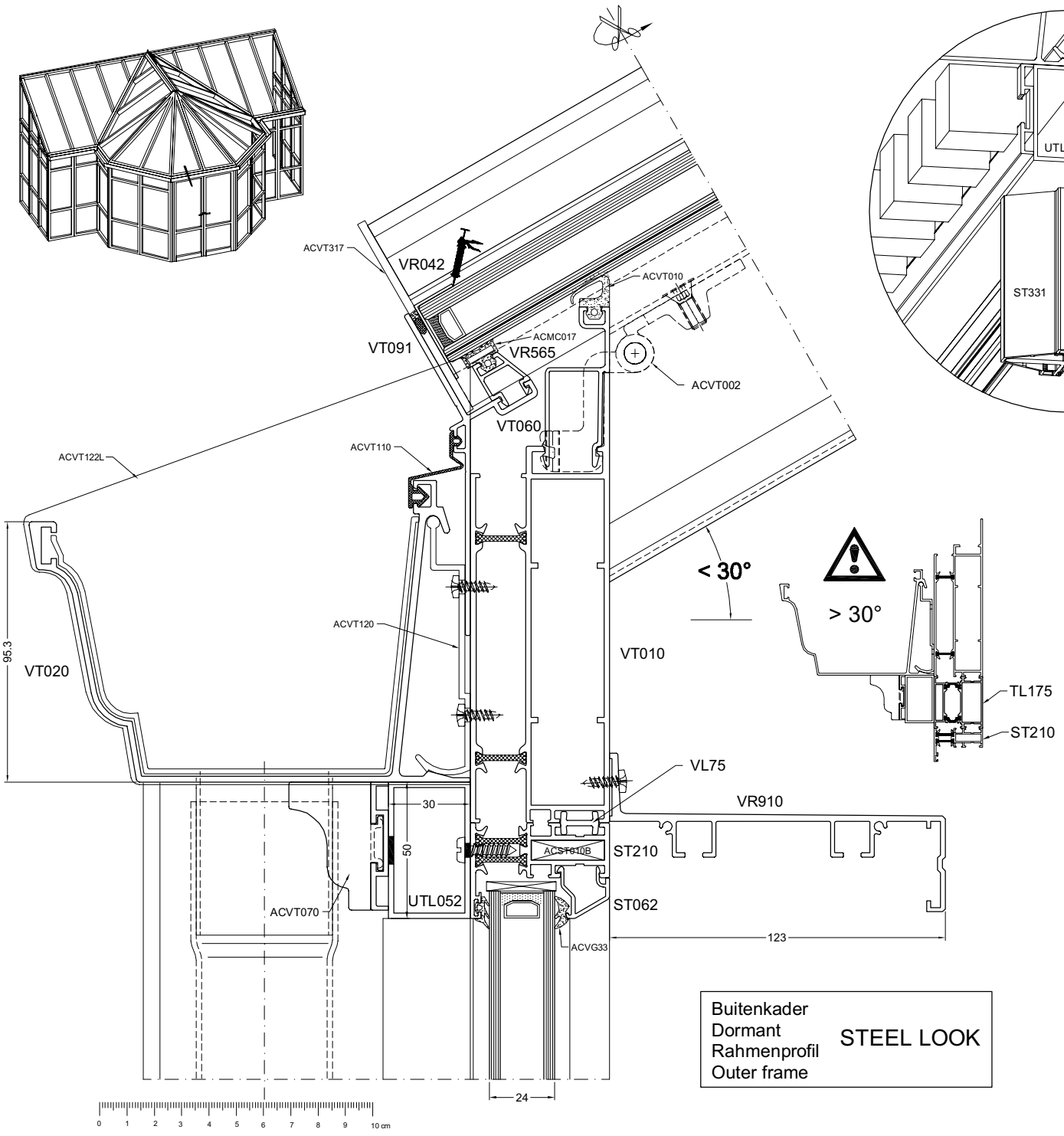

Buitenkader
Dormant
Rahmenprofil
Outer frame
STEEL LOOK

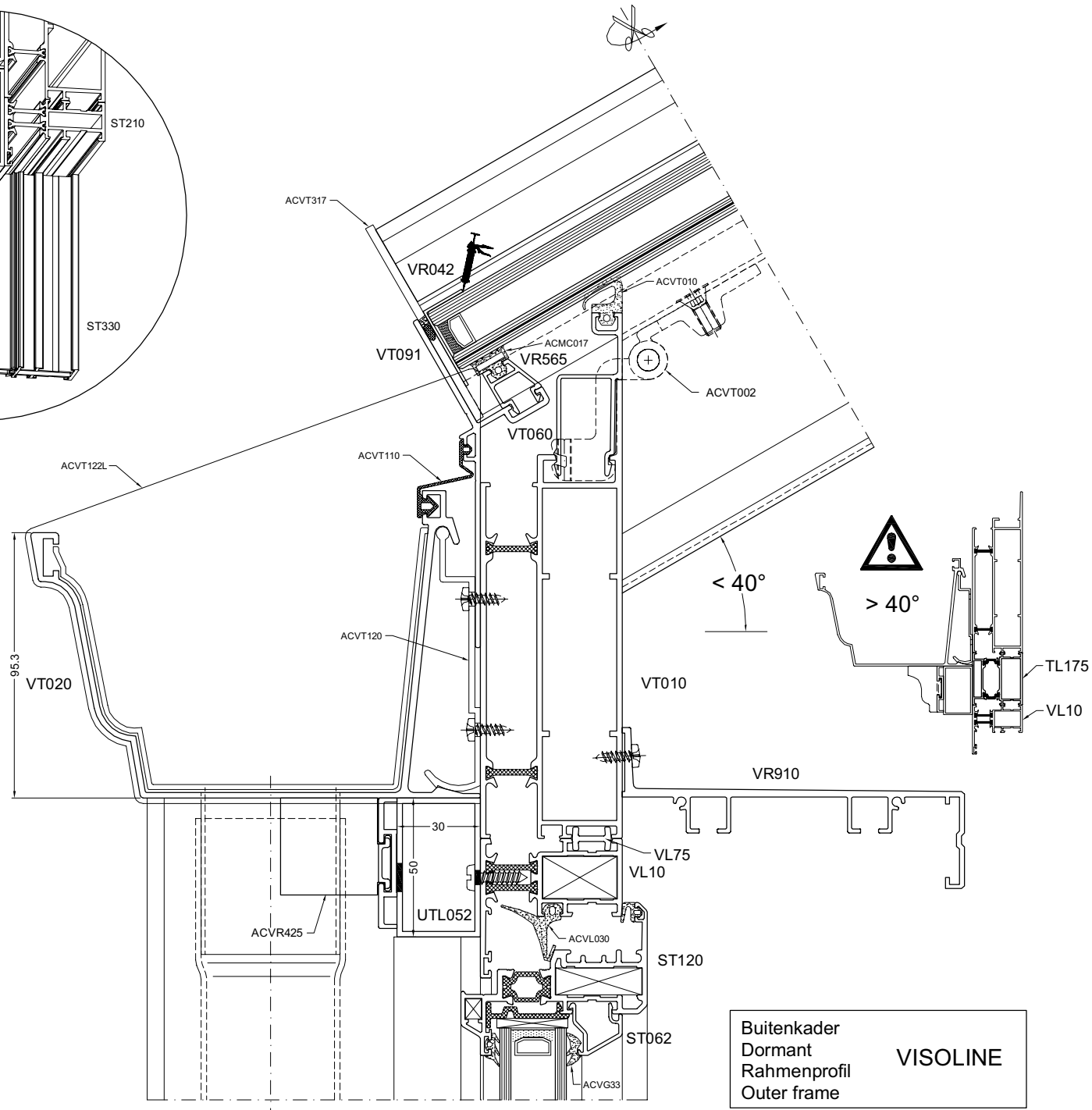

Buitenkader
Dormant
Rahmenprofil
Outer frame
VISOLINE

MONTAGE ST-VICTORIAN
MONTAGE ST-VICTORIAN
MONTAGE ST-VICTORIAN
MONTAGE ST-VICTORIAN

WERKTEKENINGEN - DESSINS DE CONSTRUCTION - KONSTRUKTIONZEICHNUNGEN - CONSTRUCTION DRAWINGS

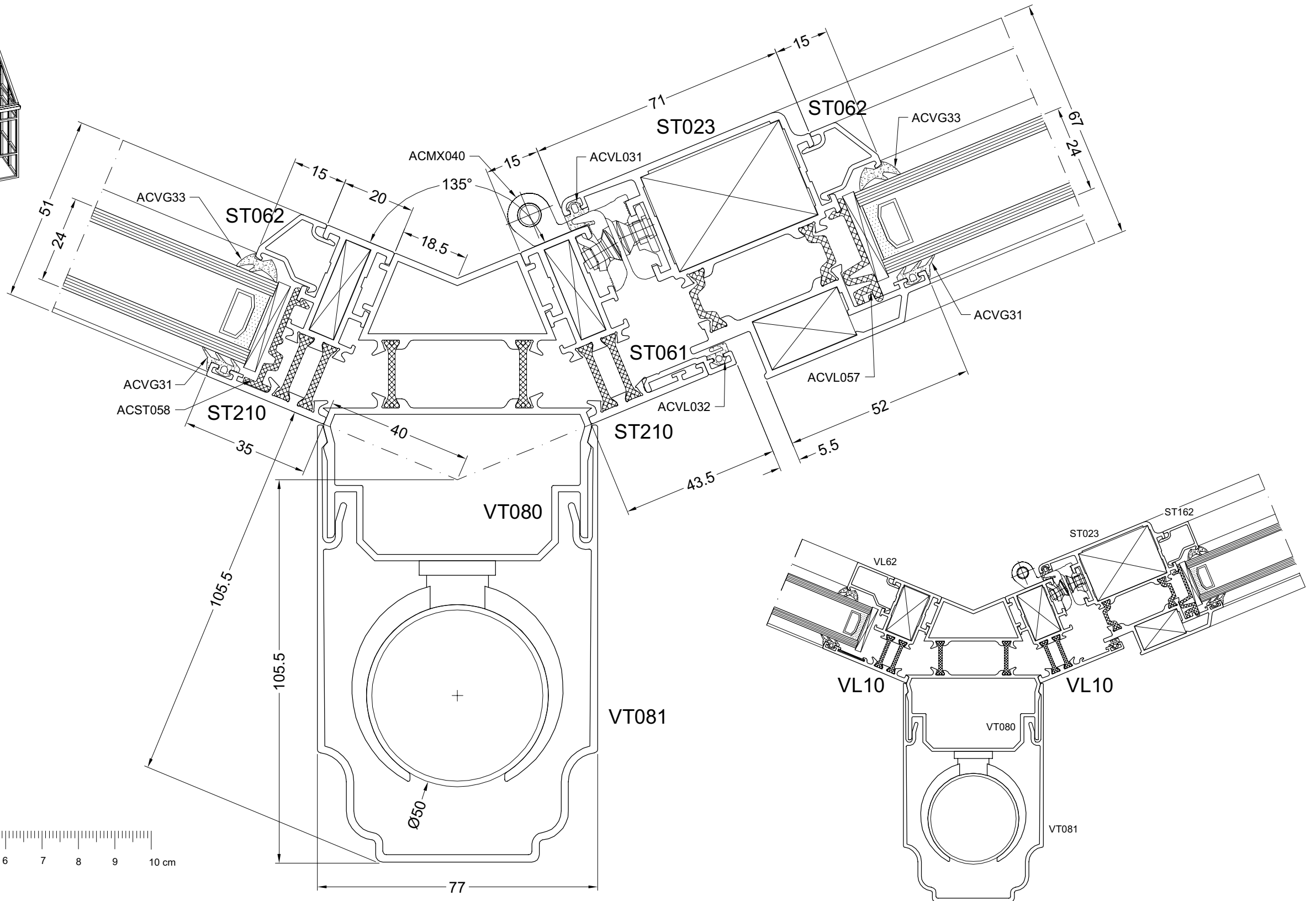
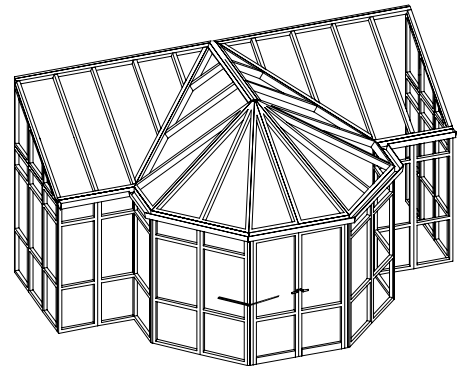

door16a

MONTAGE ST-VICTORIAN
MONTAGE ST-VICTORIAN
MONTAGE ST-VICTORIAN
MONTAGE ST-VICTORIAN

WERKTEKENINGEN - DESSINS DE CONSTRUCTION - KONSTRUKTIONZEICHNUNGEN - CONSTRUCTION DRAWINGS

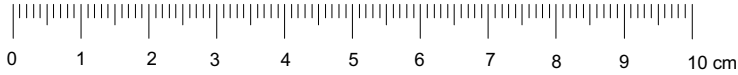
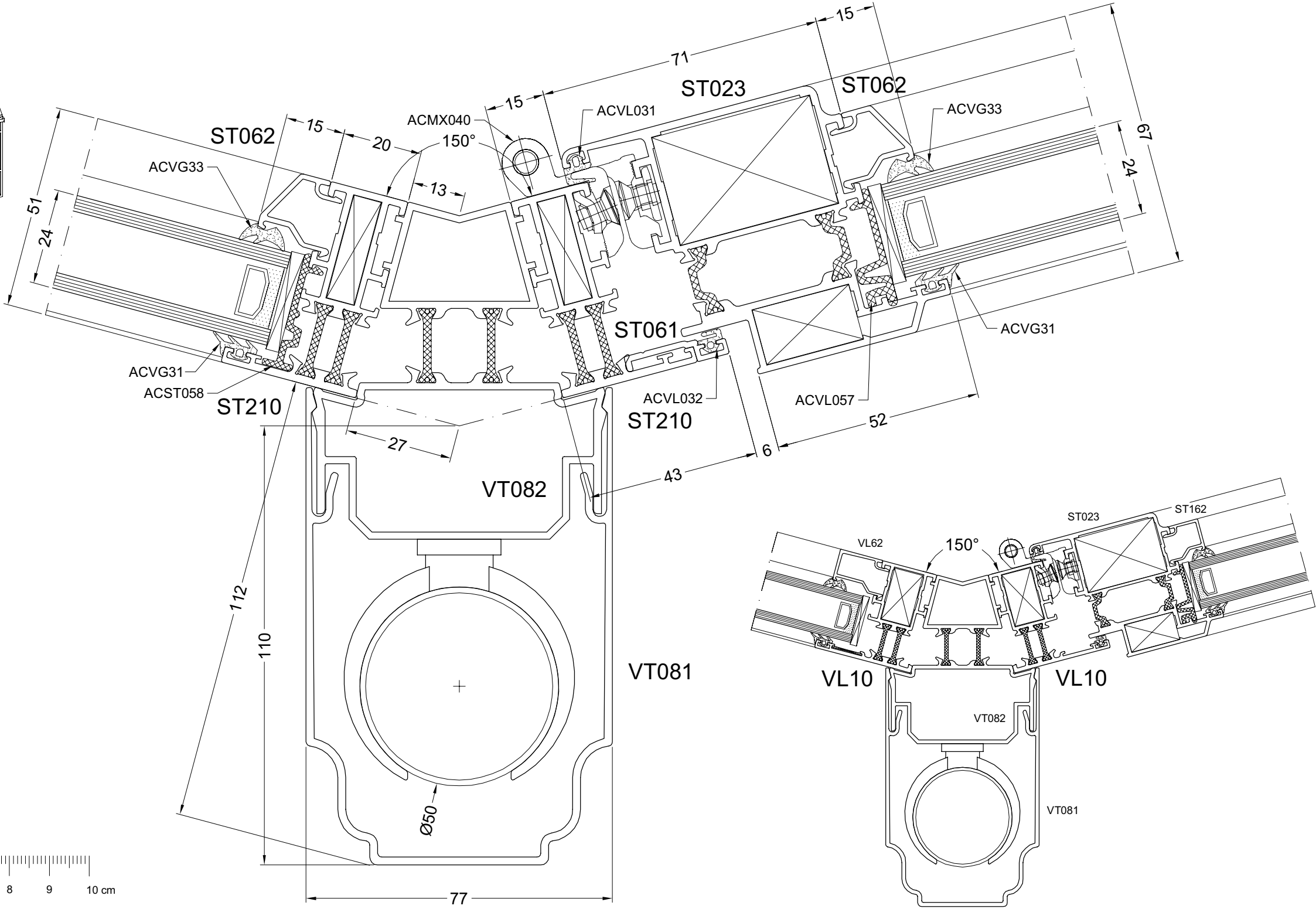
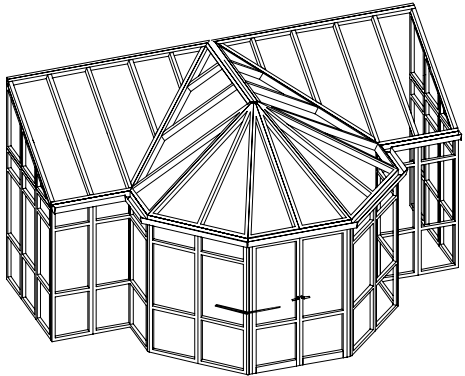

door16b

MONTAGE ST-VICTORIAN
MONTAGE ST-VICTORIAN
MONTAGE ST-VICTORIAN
MONTAGE ST-VICTORIAN

WERKTEKENINGEN - DESSINS DE CONSTRUCTION - KONSTRUKTIONZEICHNUNGEN - CONSTRUCTION DRAWINGS

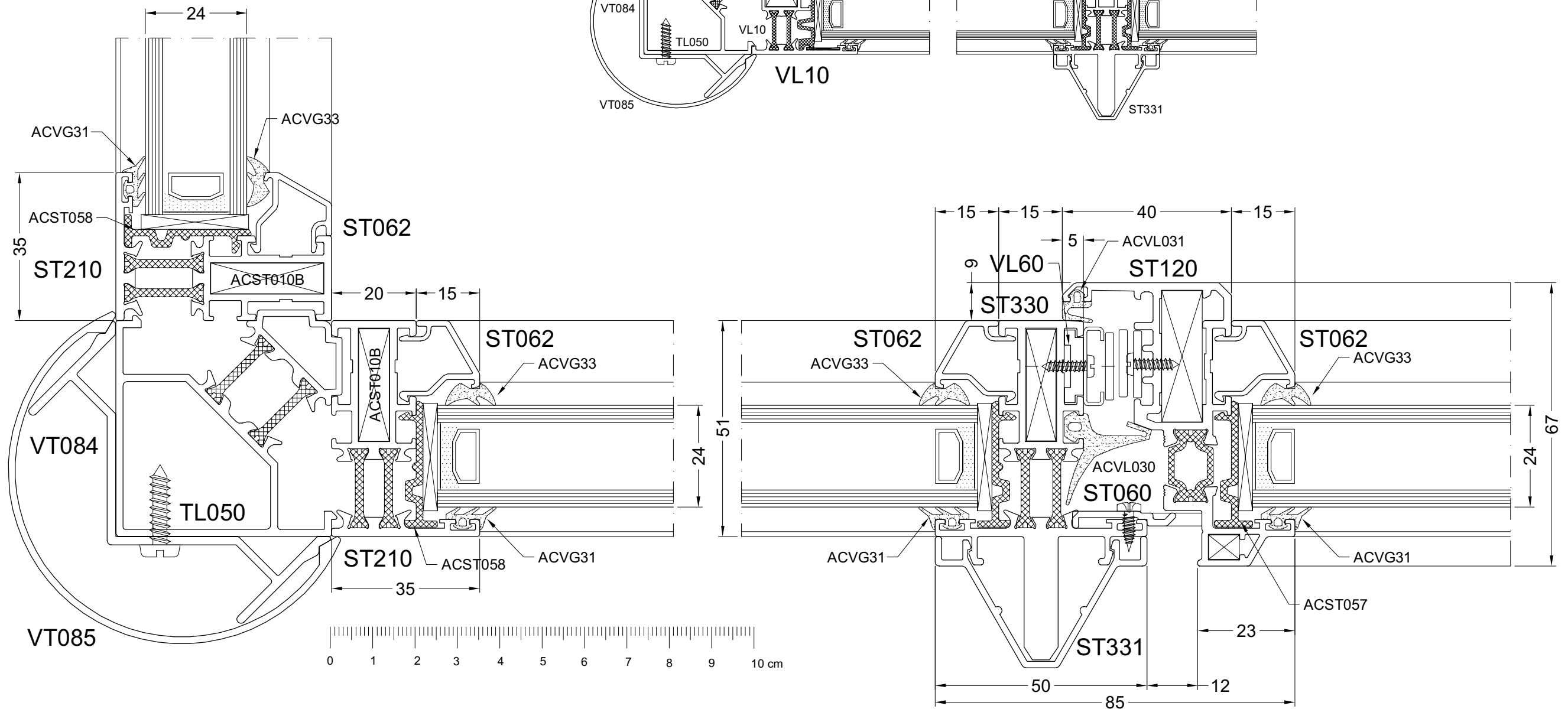
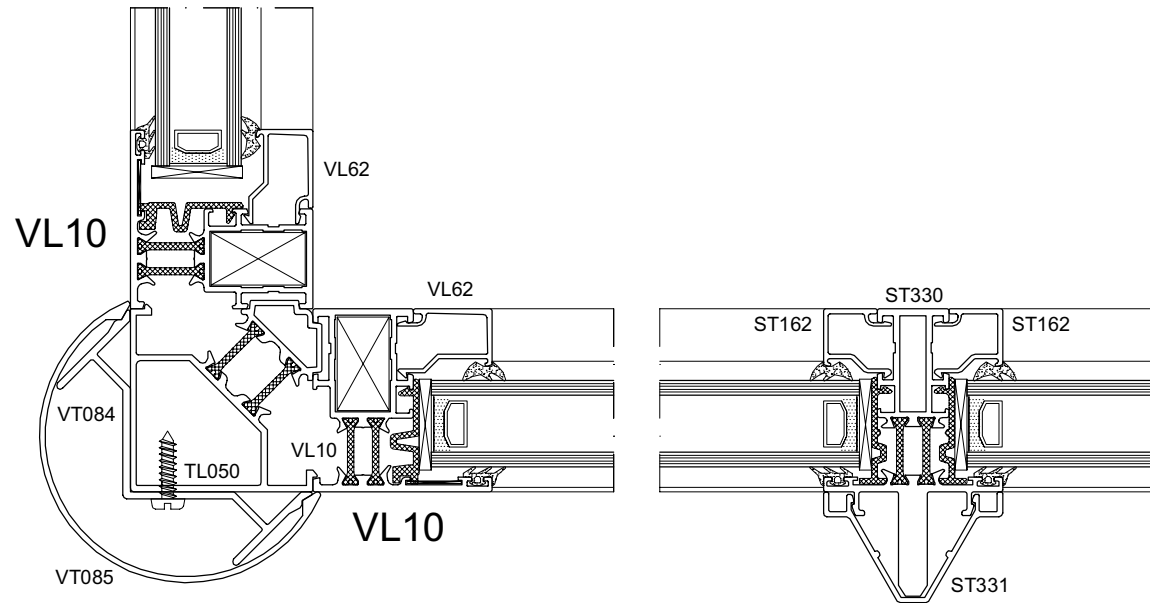
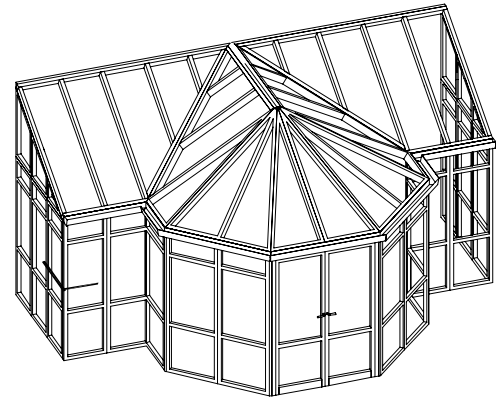

door16c

