

PROFIELEN - PROFILS - PROFILE - PROFILES

BUITENKADERS PROFILS D'ENCADREMENT KADERPROFILE OUTER FRAMES	P. 15
VLEUGELPROFIEL OUVRANT FLUGELPROFIL VENT PROFILE	P. 21
TUSSENREGELS TRAVERSES SPROSSENPROFILE TRANSOMS	P. 22
TUSSENSTIJL MAUCLAIR DICHTUNGSPROFIL MIDDLE POST	P. 24
MIDDENSTIJLEN PROFILS CHICANE WECHSELPROFIL CHICANES	P. 25
DREMPELPROFIELEN PROFILS DE SEUIL SCHWELLE SILLS	P. 26
KOPPELPROFIEL COUPLAGE KUPPLUNG COUPLING MULLION	P. 27
U PROFIEL PROFIL EN U U-PROFILE U-BAR	P. 28
GLASLATTEN LATTES A VITRAGE GLASLEISTE GLAZING BEADS	P. 29
ROLLUIKPROFIELEN PROFILS VOLET ROLLADE PROFILE SHUTTER PROFILES	P. 34

PROFIELEN - PROFILS - PROFILE - PROFILES

AANSLUITPROFIELEN _____ P. 36
PROFILS POUR CHAMBRANLES
ANSCHLIESPROFILE
CASING PROFILES

DIVERSE PROFIELEN _____ P. 37
PROFILS DIVERS
DIVERS PROFILEN
VARIED PROFILES

DOORSNEDES - COUPES - SCHNITT - SECTIONS

SCHUIFRAMEN _____ FENETRES COULISSANTES SCHIEBEFENSTER SLIDING WINDOWS	P. 71
MONORAIL _____ MONORAIL MONORAIL MONORAIL	P. 133
HEFSCHUIFRAMEN _____ FENETRES LEVANT COULISSANTES HEBESCHIEBEFENSTER LIFT SLIDING PATIODOOR	P. 149
MONORAIL HEFSCHUIF _____ MONORAIL LEVANT COULISSANTES MONORAIL HEBESCHIEBE MONORAIL LIFT SLIDING	P. 201
GLASTABELLEN _____ TABLES DE VITRAGE VERGLAZUNGS TABELLEN GLAZING TABLES	P. 215

ZAAGTABELLEN - TABLES DE SCIAGES
ZUSCHNITT-TABELLEN - SAWING TABLES

2 VLEUGELIG SCHUIFRAAM _____ P. 225
FENETRE COULISSANTE 2 VANTAUX
SCHIEBEFENSTER 2 FLUGEL
DOUBLE SLIDING WINDOW

3 VLEUGELIG SCHUIFRAAM _____ P. 227
FENETRE COULISSANTE 3 VANTAUX
SCHIEBEFENSTER 3 FLUGEL
SLIDING WINDOW WITH 3 PANELS

4 VLEUGELIG SCHUIFRAAM _____ P. 228
FENETRE COULISSANTE 4 VANTAUX
SCHIEBEFENSTER 4 FLUGEL
SLIDING WINDOW WITH 4 PANELS

MONORAIL _____ P. 230
MONORAIL
MONORAIL
MONORAIL

HEFSCHUIFRAMEN _____ P. 231
FENETRES LEVANT COULISSANTES
HEBESCHIEBEFENSTER
LIFT SLIDING PATIODOOR

WERKTEKENINGEN - DESSINS DE CONSTRUCTION***KONSTRUKTIONZEICHNUNGEN - CONSTRUCTION DRAWINGS***

MONTAGE HOEKVERBINDERS _____	P. 235
MONTAGE CLAMES	
MONTAGE ECKVERBINDERS	
MONTAGE CORNERS	
MONTAGE MONORAIL _____	P. 240
MONTAGE MONORAIL	
MONTAGE MONORAIL	
MONTAGE MONORAIL	
MONTAGE TUSSENREGELS _____	P. 241
MONTAGE TRAVERSES	
MONTAGE SPROSSENPROFILE	
MONTAGE TRANSOMS	
MONTAGE UG031 _____	P. 242
MONTAGE UG031	
MONTAGE UG031	
MONTAGE UG031	
MONTAGE ACUG028, 128 _____	P. 243
MONTAGE ACUG028, 128	
MONTAGE ACUG028, 128	
MONTAGE ACUG028, 128	
MONTAGE ACUG120 _____	P. 245
MONTAGE ACUG120	
MONTAGE ACUG120	
MONTAGE ACUG120	
MONTAGE CENTRALE DICHTINGEN _____	P. 246
MONTAGE ETANCHEITE CENTRALE	
MONTAGE MITTELDICHTUNG	
MONTAGE PLUG FOR RISERS AND ANTIDUST	
UITFREZING UG030 BIJ VASTE VLEUGEL _____	P. 250
ENTAILLE UG030 POUR VANTAIL FIXE	
EINBAU UG030 FUR FEST FLUGEL	
CUT UG030 FOR FIXED VENT	
MONTAGE ACUG044 _____	P. 251
MONTAGE ACUG044	
MONTAGE ACUG044	
MONTAGE ACUG044	
MONTAGE ACUG048 _____	P. 252
MONTAGE ACUG048	
MONTAGE ACUG048	
MONTAGE ACUG048	

WERKTEKENINGEN - DESSINS DE CONSTRUCTION**KONSTRUKTIONZEICHNUNGEN - CONSTRUCTION DRAWINGS**

MONTAGE ACUG040 _____ P. 253
MONTAGE ACUG040
MONTAGE ACUG040
MONTAGE ACUG040

MONTAGE ACUG110 _____ P. 255
MONTAGE ACUG110
MONTAGE ACUG110
MONTAGE ACUG110

MONTAGE UG140 _____ P. 256
MONTAGE UG140
MONTAGE UG140
MONTAGE UG140

ONTWATERING EN ONTLUCHTING _____ P. 257
DRAINAGE ET VENTILATION
ENTWASSERUNG UND ENTLUFTUNG
DRAINING AND VENTILATION

MONTAGE SLOT IN UG141 _____ P. 264
MONTAGE SERRURE EN UG141
MONTAGE SCHLOSS IN UG141
MONTAGE LOCK IN UG141





UITSPARING VOOR KRUKKEN _____ P. 265
ENTAILLE POUR POIGNEES
EINBAU FÜR HANDGRIFF
EMBEDDING FOR HANDLES



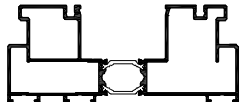
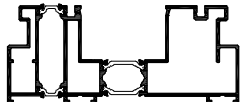
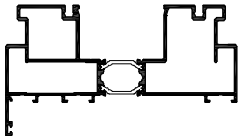
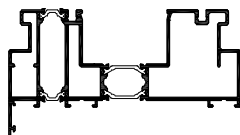

ROLLUIK _____ P. 274
VOLET
ROLLADEN FUHRUNG
ROLLING SHUTTER

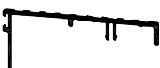

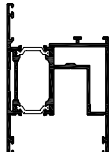
MUURAANSLUITINGEN _____ P. 275
RACCORD MACONNERIE
BAUANSCHLUSS
BUILDING CONNECTIONS

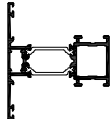
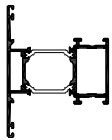
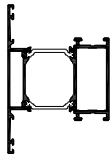



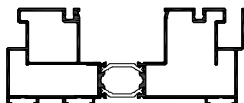

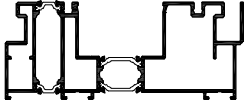
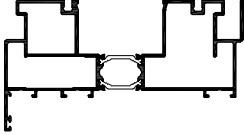
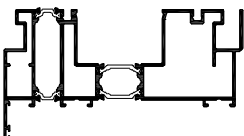
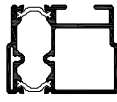

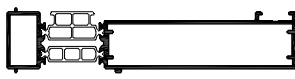
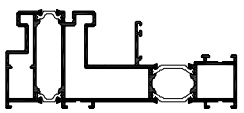
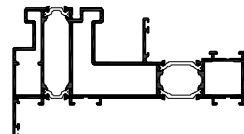
SCHEMA HEFSCHUIF BESLAG _____ P. 277
SCHEMA LEVANT COULISSANT QUINCAILLERIE
SCHEMA HEBESCHIEBE BESCHLAG
SCHEME LIFT SLIDING HARDWARE









BEWERKINGEN HEFSCHUIF _____ P. 278
OPERATION LEVANT COULISSANT
OPERATION HEBESCHIEBE
OPERATION LIFT SLIDING









NUMMER NUMERO NUMMER NUMBER	AFBEELDING IMAGE BILD PICTURE	OMSCHRIJVING DESCRIPTION BESCHREIBUNG DESCRIPTION	LENGTE LONG LANGE LENGTH
UG010		Kozijn schuifdeur Dormant coulissant Rahmen schiebetür Outer frame sliding door	7m
UG011		Kozijn schuifdeur super thermisch Dormant coulissant super thermique Rahmen schiebetür super thermisch Outer frame sliding door super thermic	7m
UG012		Kozijn schuifdeur met buitenaanslag Dormant coulissant avec battée extérieur Rahmen schiebetür mit anschlag Outer frame sliding door with rabbet	7m
UG013		Kozijn schuifdeur met buitenaanslag super thermisch Dormant coulissant avec battée extérieur super thermique Rahmen schiebetür mit anschlag super thermisch Outer frame sliding door with rabbet super thermic	7m
UG014		Drempelprofiel buiten Profil de seuil à l'extérieur Ausser Schwelle Outside sill	6.5m
UG015		Drempelprofiel binnen Profil de seuil à l'intérieur Inner Schwelle Inside sill	6.5m
UG016		Kaderprofiel drieslag schuifdeur Profil pour coulissant 3 vantaux Profil für schiebetür 3 teile Profile for sliding door 3 panels	7m
UG020		Vleugelprofiel schuifdeur Ouvrant coulissant Flügelprofil schiebetür Vent profile sliding door	6.5m









NUMMER NUMERO NUMBER	AFBEELDING IMAGE BILD PICTURE	OMSCHRIJVING DESCRIPTION BESCHREIBUNG DESCRIPTION	LENGTE LONG LANGE LENGTH
UG025		Tussenregel 77mm Travers 77mm Sprossenprofiel 77mm Transom 77mm	6.5m
UG026		Tussenregel 87mm Travers 87mm Sprossenprofiel 87mm Transom 87mm	6.5m
UG027		Tussenregel 98mm Travers 98mm Sprossenprofiel 98mm Transom 98mm	6.5m
UG030		Middenstijl schuifdeur Profil chicane coulissant Wechselprofil schiebetür Chicane for sliding door	6.5m
UG031		Verstevigingsprofiel Profil de reinforcement Verstärkungsprofil Reinforcing profile	6.5m
UG050		Isolatieprofiel PVC voor schuifdeur Profil d'isolation pour coulissant Schranke aus PVC für Schiebetür PVC thermal break profile	7m
UG051		Haakprofiel PVC voor schuifdeur Chicane PVC pour coulissant Schikane PVC für Schiebetür PVC chicane for sliding door	6.5m
UG110		Verlaagd kozijn schuifdeur Baissant dormant coulissant Gesenk Rahmen schiebetür Lowered outer frame sliding door	7m





NUMMER NUMERO NUMMER NUMBER	AFBEELDING IMAGE BILD PICTURE	OMSCHRIJVING DESCRIPTION BESCHREIBUNG DESCRIPTION	LENGTE LONG LANGE LENGTH
UG111		Verlaagd kozijn schuifdeur super thermisch Baissant dormant coulissant super thermique Gesenkt Rahmen schiebetür super thermisch Lowered outer frame sliding door super thermic	7m
UG112		Verlaagd kozijn schuifdeur met buitenaanslag Baissant dormant coulissant avec battée extérieur Gesenkt Rahmen schiebetür mit anschlag Lowered outer frame sliding door with rabbet	7m
UG113		Verlaagd kozijn schuifdeur met buitenaanslag super therm. Baissant dormant coulissant avec battée ext. super thermique Gesenkt Rahmen schiebetür mit anschlag super thermisch Lowered outer frame sliding door with rabbet super thermic	7m
UG140		Tussenstijl vierslag schuifdeur Mauclair 4 vantaux coulissant Dichtungsprofil für 4-teiliges Schiebetür Middle post sliding door 4 panels	6.5m
UG141		Tussenstijl vierslag hefschuifdeur Mauclair 4 vantaux levant coulissant Dichtungsprofil für 4-teiliges hebe Schiebetür Middle post sliding patio door 4 panels	6.5m
UG150		Koppelprofiel Couplage Küplung Coupling mullion	6.5m
UG610		Monorail super thermisch Monorail super thermique Monorail super thermisch Monorail super thermic	7m
UG612		Monorail super thermisch met buitenaanslag Monorail super thermique avec battée extérieur Monorail super thermisch mit anschlag Monorail super thermic with rabbet	7m

NUMMER NUMERO NUMBER	AFBEELDING IMAGE BILD PICTURE	OMSCHRIJVING DESCRIPTION BESCHREIBUNG DESCRIPTION	LENGTE LONG LANGE LENGTH
UG614		Drempelprofiel 29mm Profil de seuil 29mm Schwelle 29mm Sill clips 29mm	6.5m
IP063		Glaslat 28mm Latte à vitrage 28mm Glasleiste 28mm Glazing bead 28mm	6.5m
IP064		Glaslat 39mm Latte à vitrage 39mm Glasleiste 39mm Glazing bead 39mm	6.5m
IP065		Glaslat 48mm Latte à vitrage 48mm Glasleiste 48mm Glazing bead 48mm	6.5m
IP561		Glaslat 4mm Latte à vitrage 4mm Glasleiste 4mm Glazing bead 4mm	6.5m
IP564		Glaslat 26mm Latte à vitrage 26mm Glasleiste 26mm Glazing bead 26mm	6.5m
IP566		Glaslat 21.5mm Latte à vitrage 21.5mm Glasleiste 21.5mm Glazing bead 21.5mm	6.5m
IP568		Glaslat 30mm Latte à vitrage 30mm Glasleiste 30mm Glazing bead 30mm	6.5m

NUMMER NUMERO NUMBER NUMBER	AFBEELDING IMAGE BILD PICTURE	OMSCHRIJVING DESCRIPTION BESCHREIBUNG DESCRIPTION	LENGTE LONG LANGE LENGTH
IP569		Glaslat 34mm Latte à vitrage 34mm Glasleiste 34mm Glazing bead 34mm	6.5m
SP065		Glaslat 37mm Latte à vitrage 37mm Glasleiste 37mm Glazing bead 37mm	6.5m
SP066		Glaslat 41mm Latte à vitrage 41mm Glasleiste 41mm Glazing bead 41mm	6.5m
SP067		Glaslat 45mm Latte à vitrage 45mm Glasleiste 45mm Glazing bead 45mm	6.5m
SR014		Clips Clips Klippeprofil Finishing profile	7m
UTL029		U profiel 20X30X20X2 Profil en U 20X30X20X2 U Profile 20X30X20X2 U bar 20X30X20X2	6m
VG52		Afwerkingsprofiel PVC Profil de finition PVC Zierleiste PVC Ornamental strip PVC	7m
VG53		Inox geleidingsstrip Rail inox pour coulissant Inox Schiene für Schiebetür Inox rail for sliding door	6.5m

NUMMER NUMERO NUMBER	AFBEELDING IMAGE BILD PICTURE	OMSCHRIJVING DESCRIPTION BESCHREIBUNG DESCRIPTION	LENGTE LONG LANGE LENGTH
VG53A		Alu geleidingsstrip Rail alu pour coulissant Alu Schiene für Schiebetür Alu rail for sliding door	6.5m
VL61		Glaslat 4mm Latte à vitrage 4mm Glasleiste 4mm Glazing bead 4mm	6.5m
VL62		Glaslat 16mm Latte à vitrage 16mm Glasleiste 16mm Glazing bead 16mm	6.5m
VL63		Glaslat 20mm Latte à vitrage 20mm Glasleiste 20mm Glazing bead 20mm	6.5m
VL64		Glaslat 26mm Latte à vitrage 26mm Glasleiste 26mm Glazing bead 26mm	6.5m
VL65		Glaslat 34mm Latte à vitrage 34mm Glasleiste 34mm Glazing bead 34mm	6.5m
VL70		Rolluikgeleider Guide à volet Rolladenführung Shutter guide	6.5m
VL71		Inloop rolluikgeleider Entree guide à volet Einlauf Rolladenführung Entrance shutter guide	4.5m 6.5m

NUMMER NUMERO NUMBER NUMBER	AFBEELDING IMAGE BILD PICTURE	OMSCHRIJVING DESCRIPTION BESCHREIBUNG DESCRIPTION	LENGTE LONG LANGE LENGTH
VL77		Aansluitprofiel Profilé pour chambranle Anschliesprofil Casing profile	6.5m
VL78		Aansluitprofiel voor 18mm plaat Profilé pour chambranle pour plaque 18mm Anschliesprofil für 18mm platte Casing profile for 18mm plate	6.5m
VL170		Dubbele rolluikgeleider Guide à volet double Doppelt Rolladenführung Double shutter guide	6.5m
VL171		Rolluikgeleider Guide à volet Rolladenführung Shutter guide	6.5m
VL172		Rolluik lamel Lamelle pour volet Rolladen Lamelle Shutter Lamella	6.5m
VL561		Glaslat 12mm Latte à vitrage 12mm Glasleiste 12mm Glazing bead 12mm	6.5m
VL562		Glaslat 16mm Latte à vitrage 16mm Glasleiste 16mm Glazing bead 16mm	6.5m
VL610		Glaslat 8mm Latte à vitrage 8mm Glasleiste 8mm Glazing bead 8mm	6.5m

NUMMER NUMERO NUMMER NUMBER	AFBEELDING IMAGE BILD PICTURE	OMSCHRIJVING DESCRIPTION BESCHREIBUNG DESCRIPTION	LENGTE LONG LANGE LENGTH
VL611		Glaslat 12mm Latte à vitrage 12mm Glasleiste 12mm Glazing bead 12mm	6.5m
VL612		Glaslat 14mm Latte à vitrage 14mm Glasleiste 14mm Glazing bead 14mm	6.5m
VL630		Glaslat 23mm Latte à vitrage 23mm Glasleiste 23mm Glazing bead 23mm	6.5m
VL640		Glaslat 30mm Latte à vitrage 30mm Glasleiste 30mm Glazing bead 30mm	6.5m

BUITENKADERS
 PROFILS D'ENCADREMENT
 KADERPROFILE
 OUTER FRAMES

PROFIELEN - PROFILS - PROFILE - PROFILES

UG010

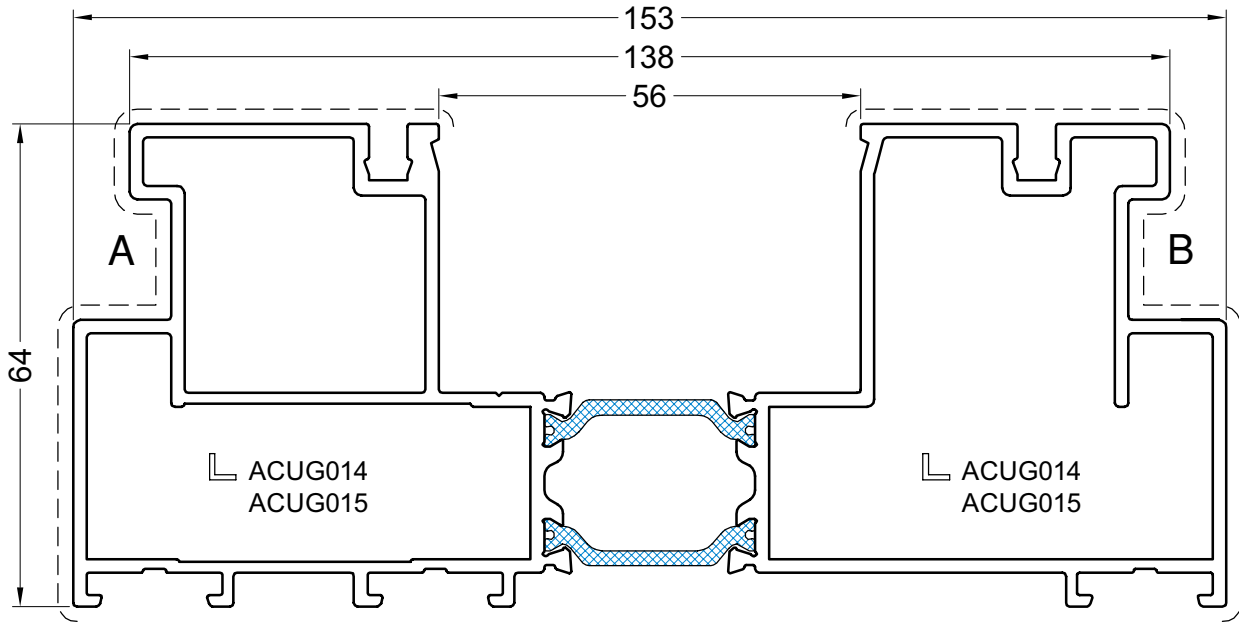

$I_x = 287.53 \text{ cm}^4$
 $I_y = 51.78 \text{ cm}^4$
 $W_x = 36.96 \text{ cm}^3$
 $W_y = 15.72 \text{ cm}^3$

UG012

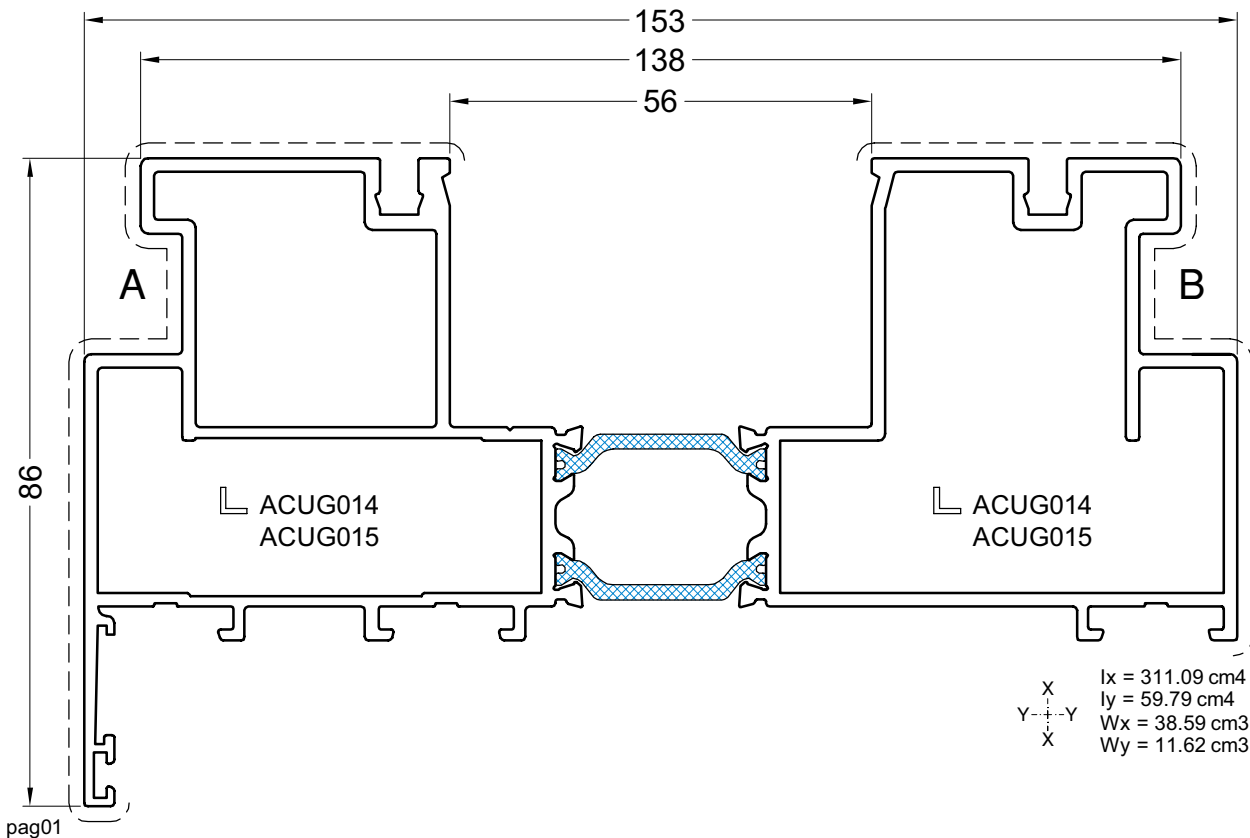

$I_x = 311.09 \text{ cm}^4$
 $I_y = 59.79 \text{ cm}^4$
 $W_x = 38.59 \text{ cm}^3$
 $W_y = 11.62 \text{ cm}^3$

UG110

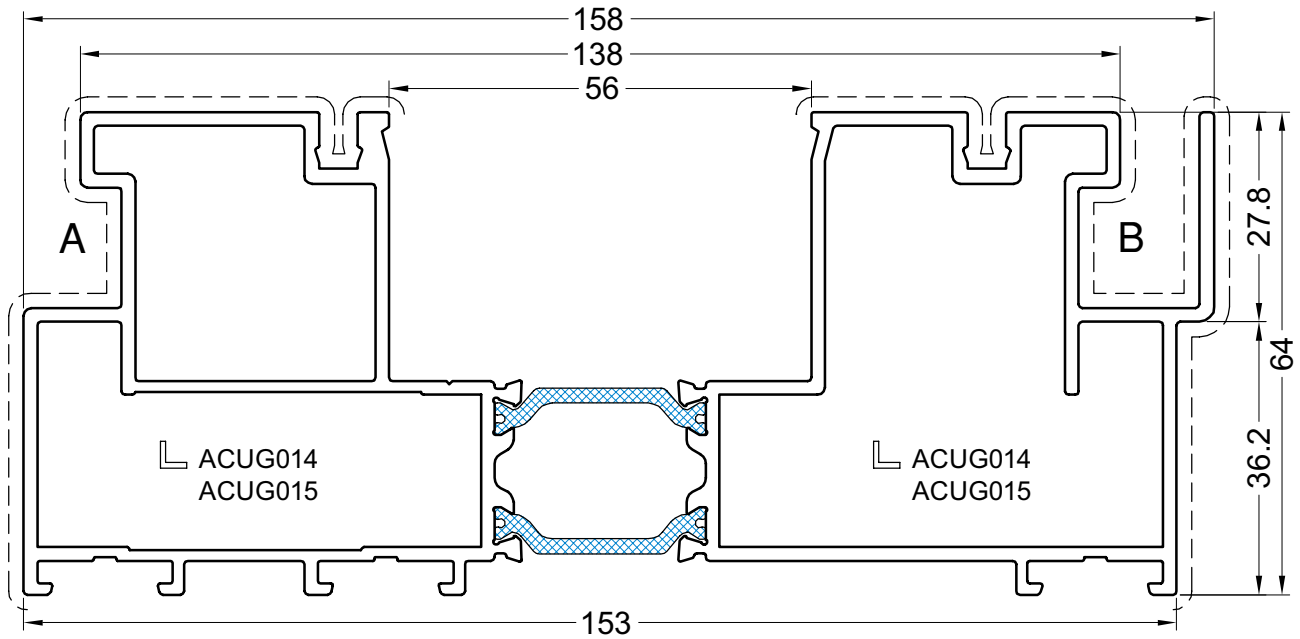

$I_x = 325.63 \text{ cm}^4$
 $I_y = 54.07 \text{ cm}^4$
 $W_x = 41.04 \text{ cm}^3$
 $W_y = 16.88 \text{ cm}^3$

UG112

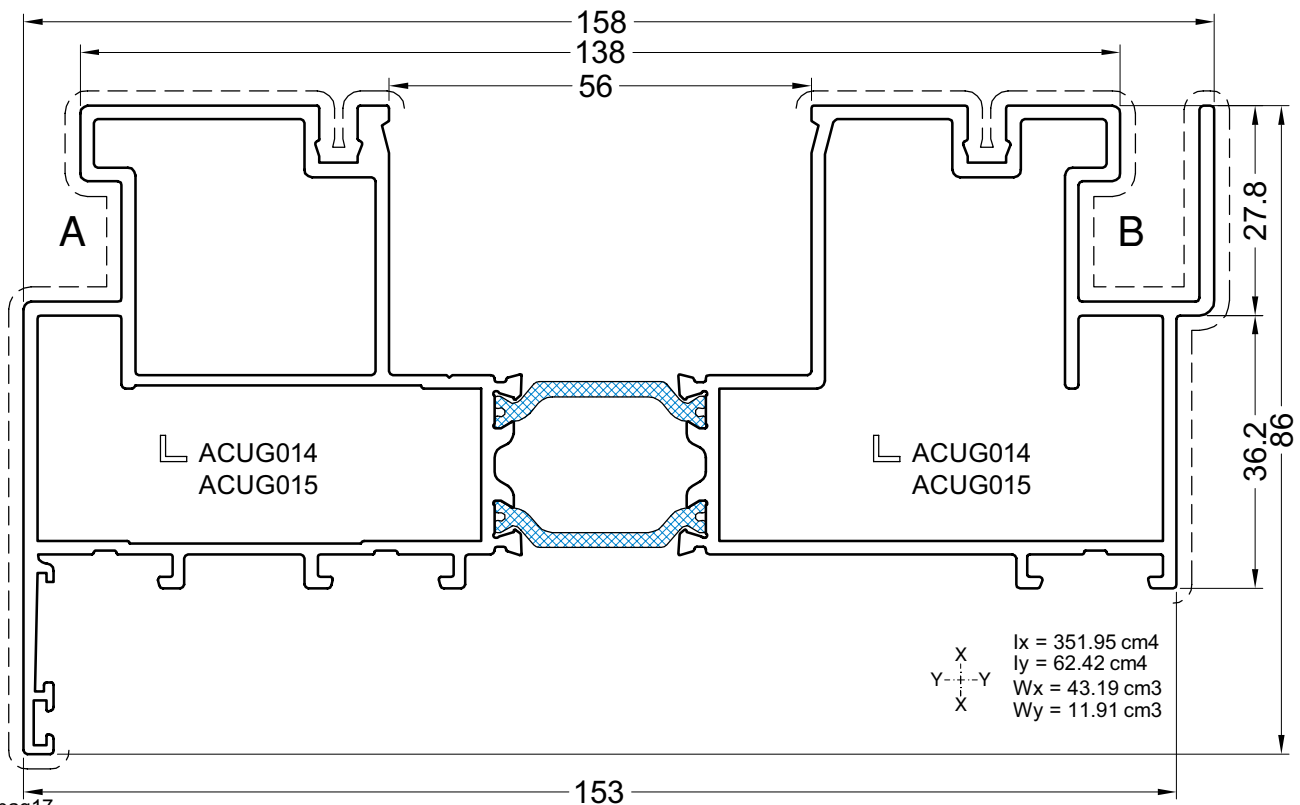

$I_x = 351.95 \text{ cm}^4$
 $I_y = 62.42 \text{ cm}^4$
 $W_x = 43.19 \text{ cm}^3$
 $W_y = 11.91 \text{ cm}^3$

pag17

BUITENKADERS
 PROFILS D'ENCADREMENT
 KADERPROFILE
 OUTER FRAMES

PROFIELEN - PROFILS - PROFILE - PROFILES

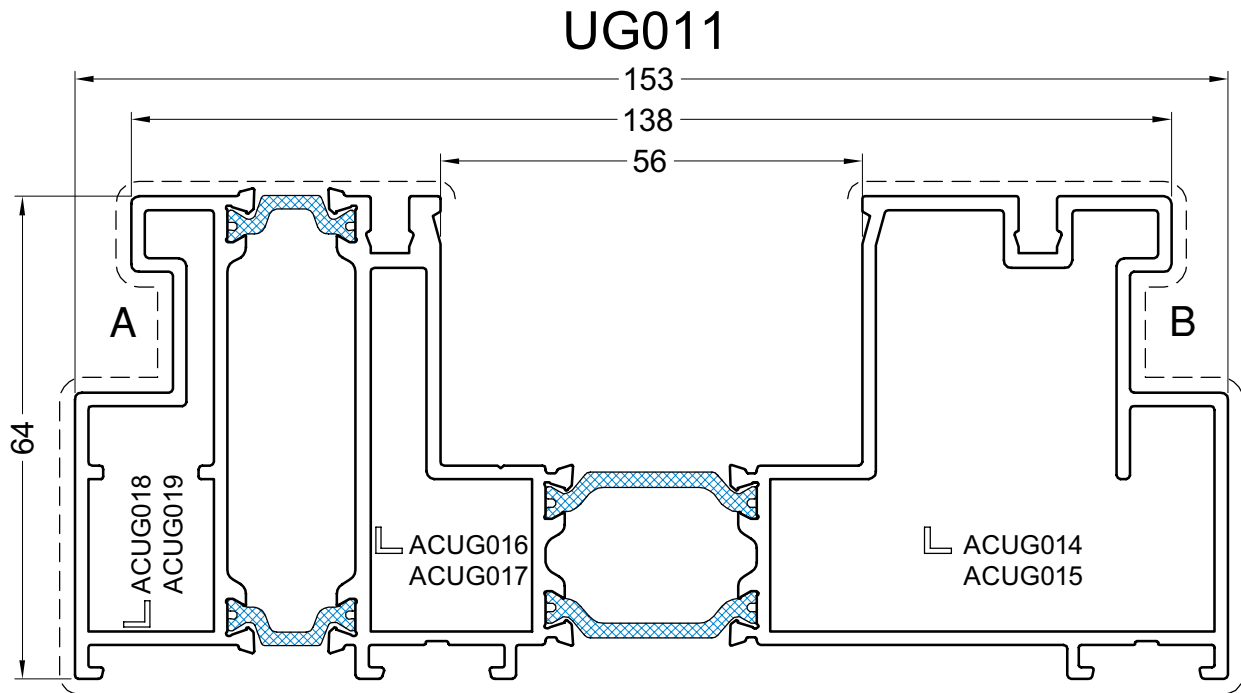

X	$I_x = 315.71 \text{ cm}^4$
Y	$I_y = 55.23 \text{ cm}^4$
X	$W_x = 38.06 \text{ cm}^3$
Y	$W_y = 16.34 \text{ cm}^3$

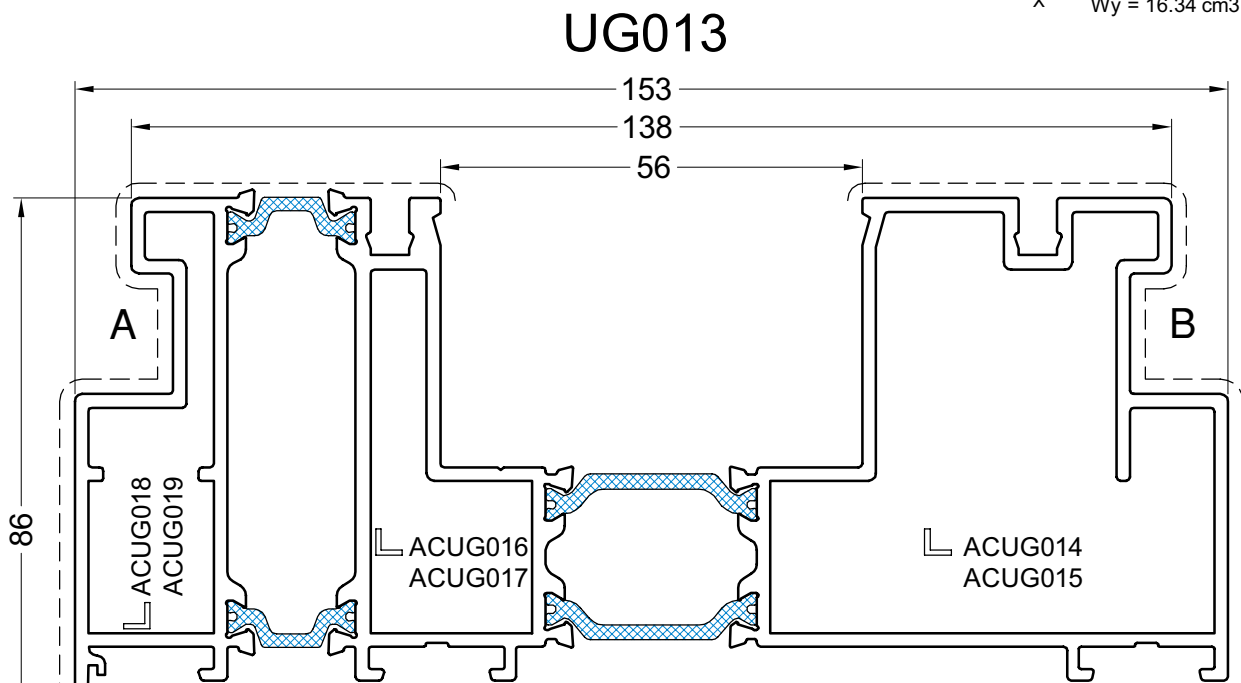

X	$I_x = 338.98 \text{ cm}^4$
Y	$I_y = 64.41 \text{ cm}^4$
X	$W_x = 38.97 \text{ cm}^3$
Y	$W_y = 12.79 \text{ cm}^3$

pag16

UG111

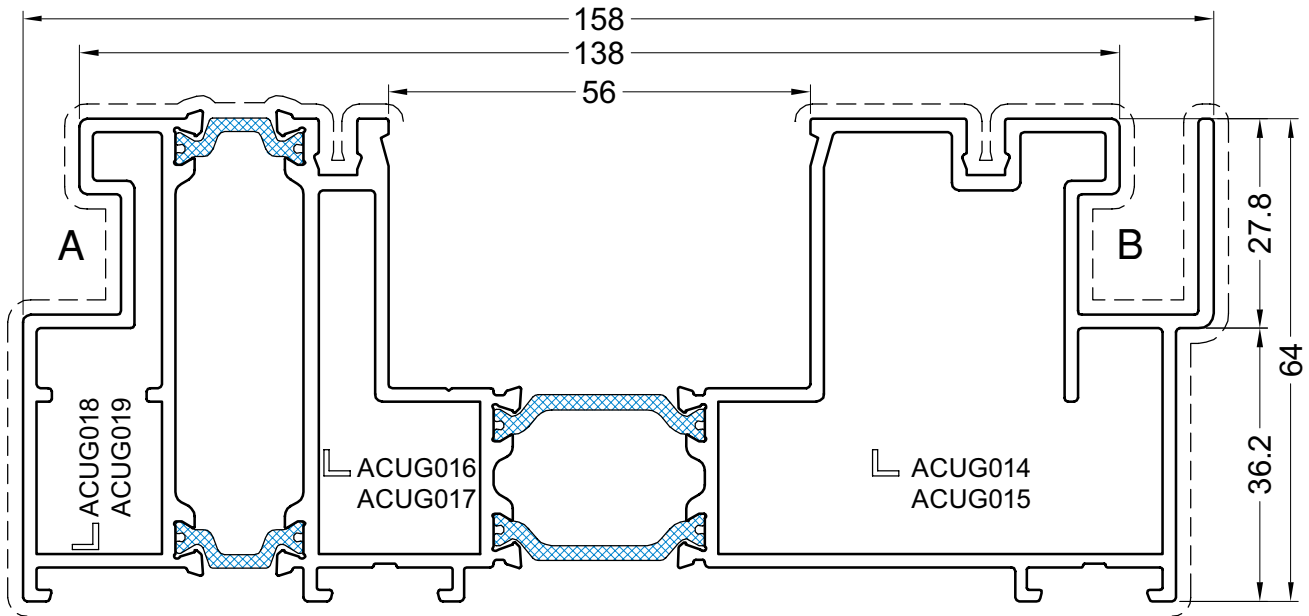

$I_x = 359.03 \text{ cm}^4$
 $I_y = 57.48 \text{ cm}^4$
 $W_x = 42.73 \text{ cm}^3$
 $W_y = 17.41 \text{ cm}^3$

UG113

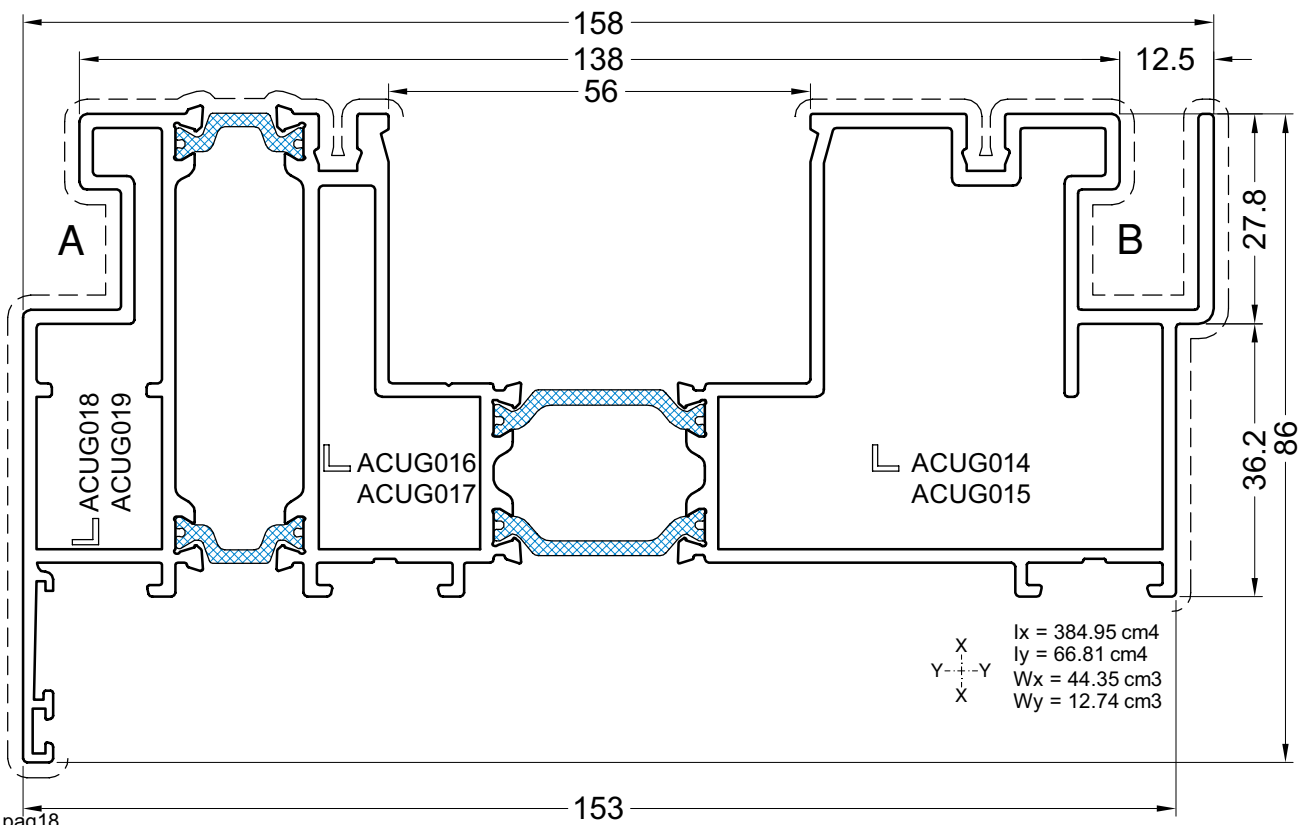

$I_x = 384.95 \text{ cm}^4$
 $I_y = 66.81 \text{ cm}^4$
 $W_x = 44.35 \text{ cm}^3$
 $W_y = 12.74 \text{ cm}^3$

pag18

BUITENKADERS
 PROFILS D'ENCADREMENT
 KADERPROFILE
 OUTER FRAMES

PROFIELEN - PROFILS - PROFILE - PROFILES

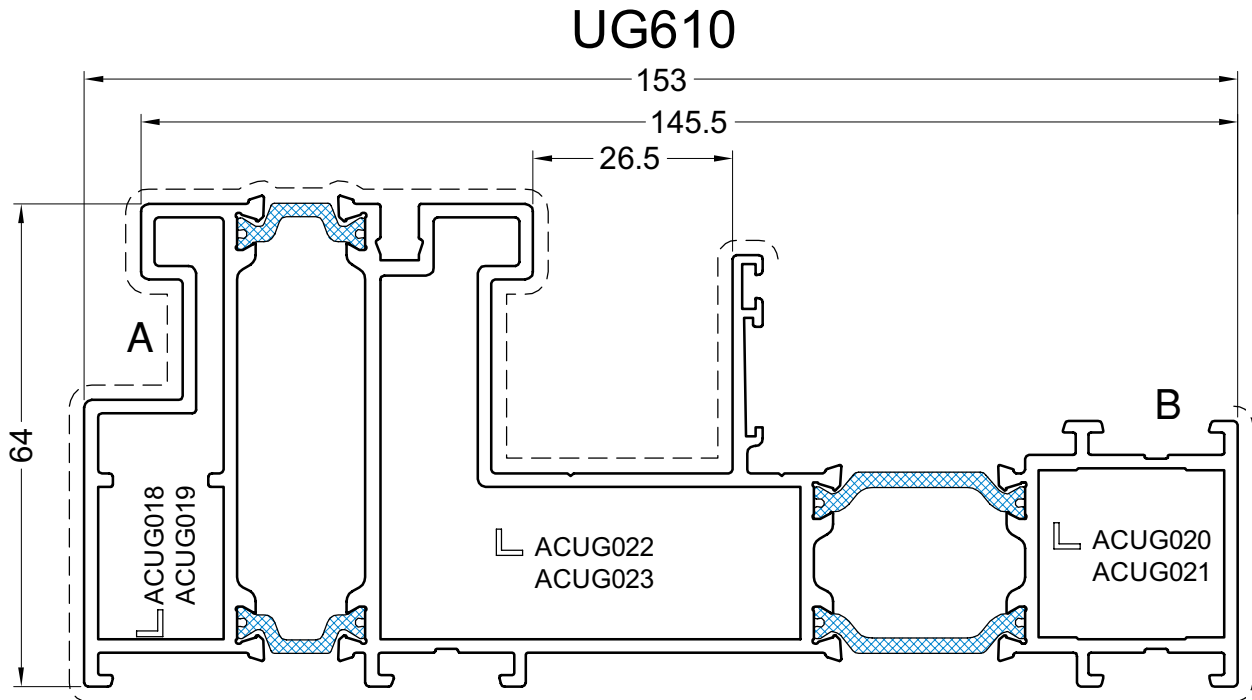

X	$I_x = 263.09 \text{ cm}^4$
Y	$I_y = 44.55 \text{ cm}^4$
X	$W_x = 29.70 \text{ cm}^3$
X	$W_y = 12.03 \text{ cm}^3$

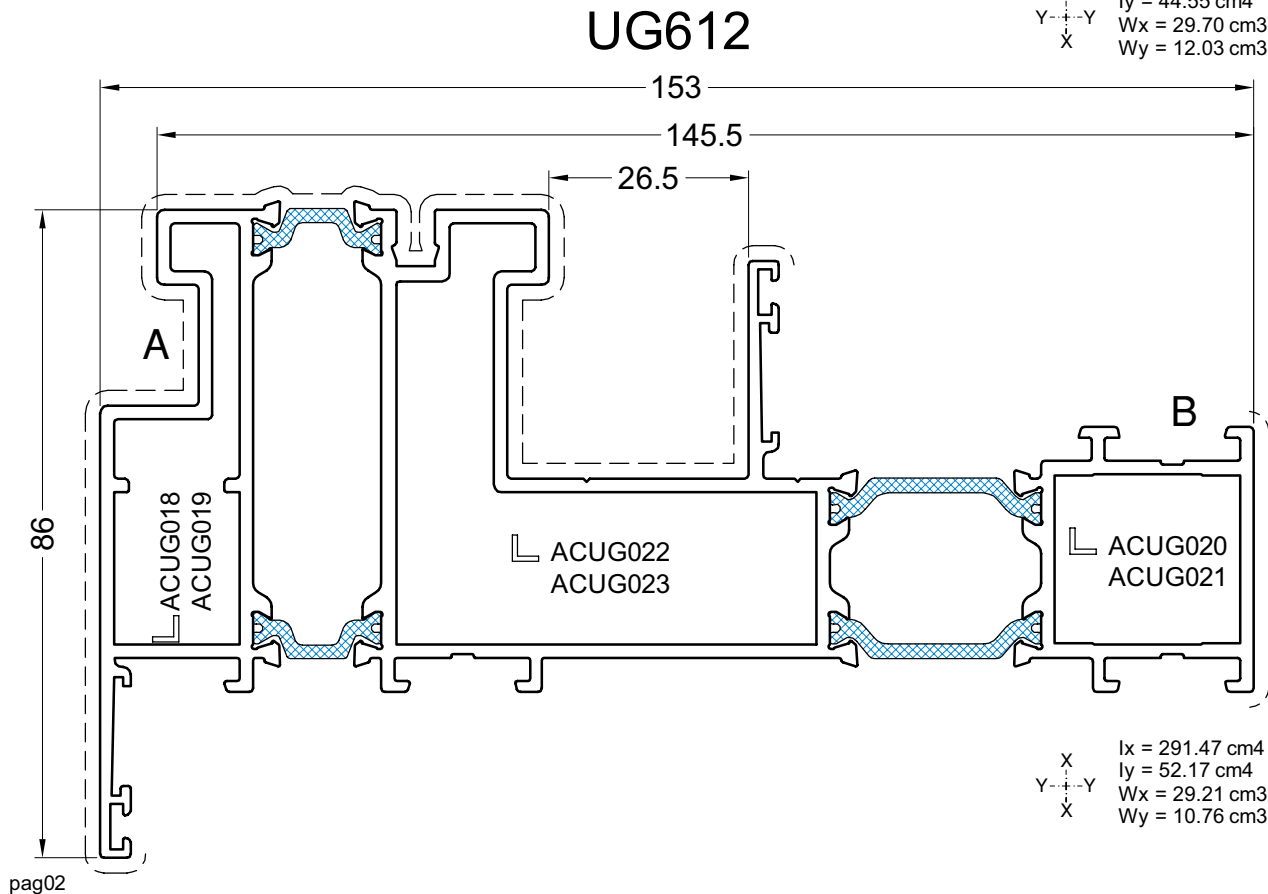

X	$I_x = 291.47 \text{ cm}^4$
Y	$I_y = 52.17 \text{ cm}^4$
X	$W_x = 29.21 \text{ cm}^3$
X	$W_y = 10.76 \text{ cm}^3$

pag02

UG016

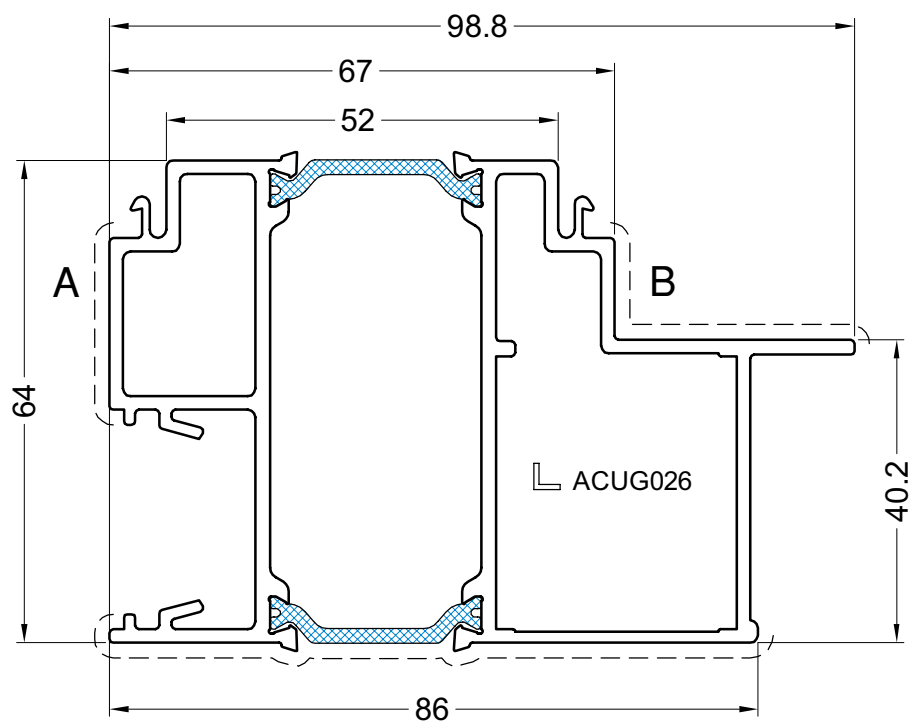

$I_x = 61.92 \text{ cm}^4$
 $I_y = 34.15 \text{ cm}^4$
 $W_x = 10.81 \text{ cm}^3$
 $W_y = 10.26 \text{ cm}^3$

SR014

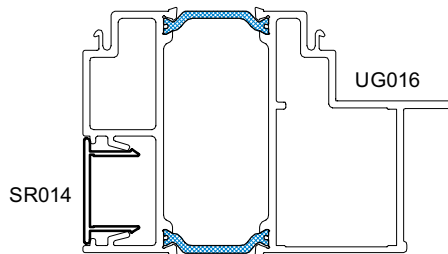
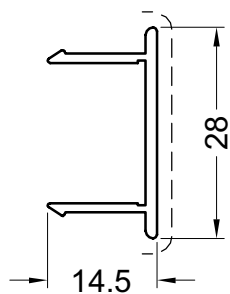

VLEUGELPROFIEL
OUVRANT
FLUGELPROFILE
VENT PROFILE

UG020

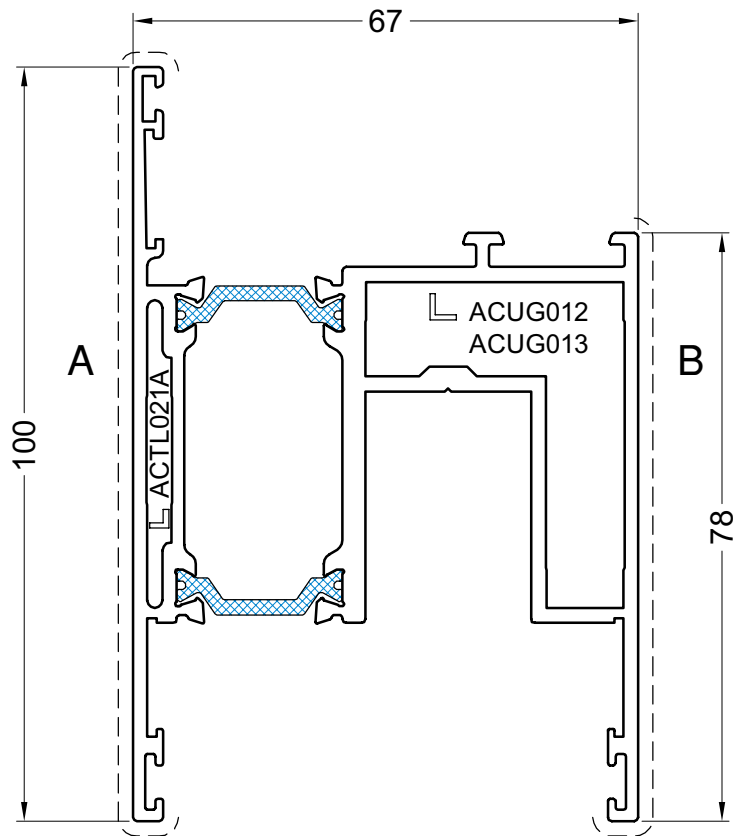

X	lx = 53.60 cm ⁴
Y	ly = 42.71 cm ⁴
X	Wx = 14.92 cm ³
Y	Wy = 8.35 cm ³

PROFIELEN - PROFILS - PROFILE - PROFILES

TUSSENREGELS
 TRAVERSES
 SPROSSENPROFILE
 TRANSOMS

UG025

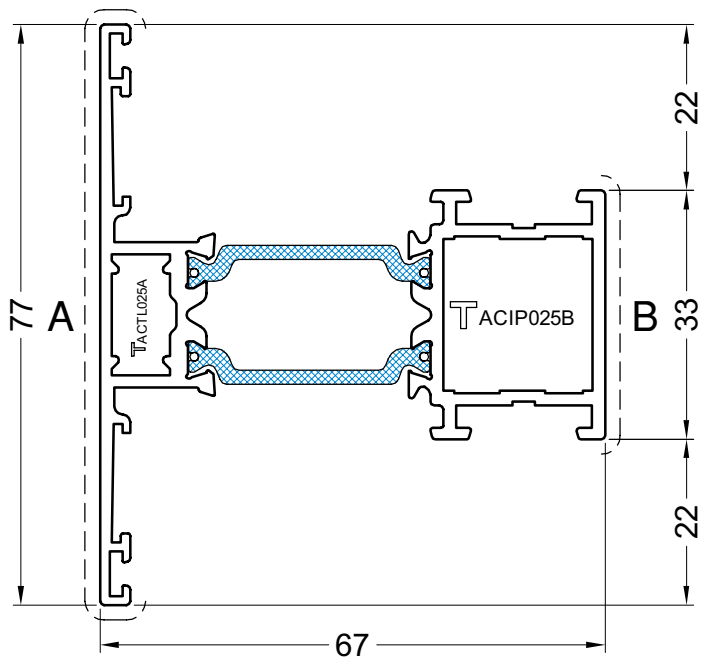

$I_x = 30.56 \text{ cm}^4$
 $I_y = 10.93 \text{ cm}^4$
 $W_x = 7.81 \text{ cm}^3$
 $W_y = 2.84 \text{ cm}^3$

UG026

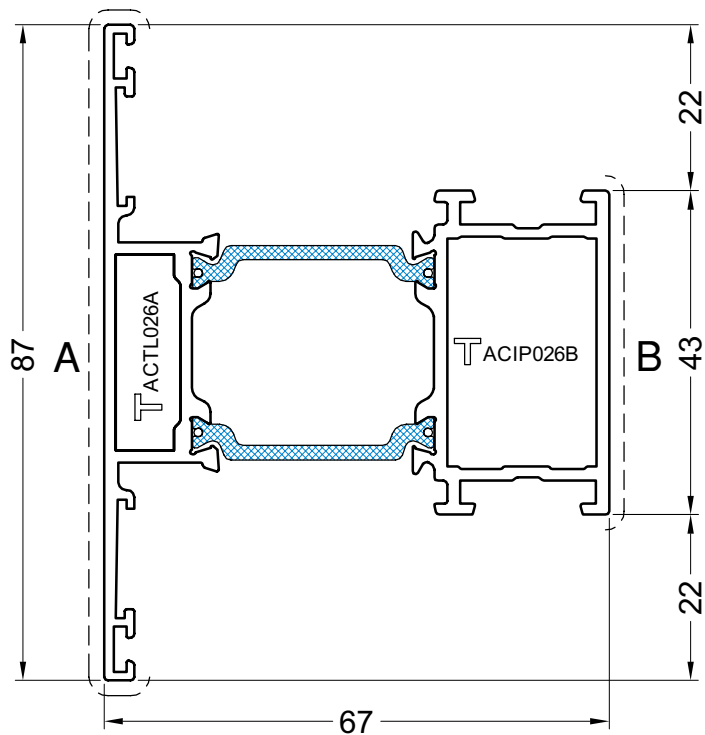

$I_x = 34.67 \text{ cm}^4$
 $I_y = 17.81 \text{ cm}^4$
 $W_x = 9.07 \text{ cm}^3$
 $W_y = 4.09 \text{ cm}^3$

TUSSENREGELS
 TRAVERSES
 SPROSSENPROFILE
 TRANSOMS

UG027

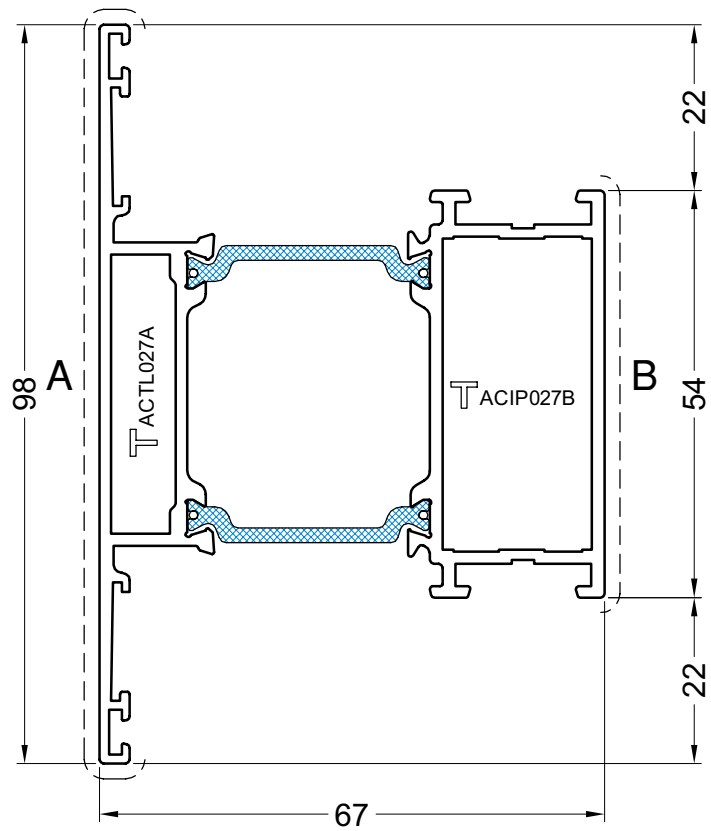

X
 Y---Y
 X
 Ix = 39.53 cm⁴
 Iy = 28.45 cm⁴
 Wx = 10.44 cm³
 Wy = 5.81 cm³

TUSSENSTIJL
MAUCLAIR
DICHTUNGSPROFIL
MIDDLE POST

UG140

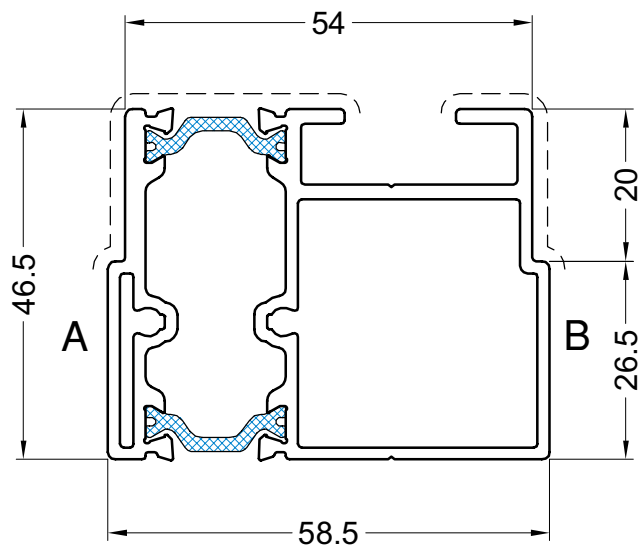

$I_x = 21.01 \text{ cm}^4$
 $I_y = 12.46 \text{ cm}^4$
 $W_x = 6.49 \text{ cm}^3$
 $W_y = 5.32 \text{ cm}^3$

UG141

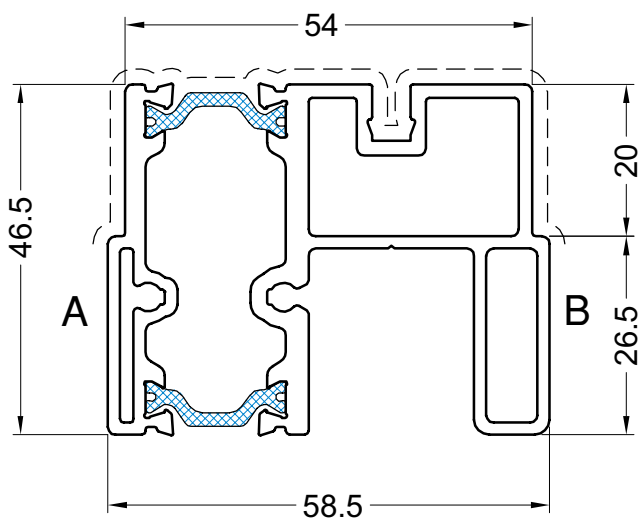

$I_x = 22.81 \text{ cm}^4$
 $I_y = 12.93 \text{ cm}^4$
 $W_x = 7.36 \text{ cm}^3$
 $W_y = 5.21 \text{ cm}^3$

MIDDENSTIJLEN
 PROFILS CHICANE
 WECHSELPROFIL
 CHICANES

UG030

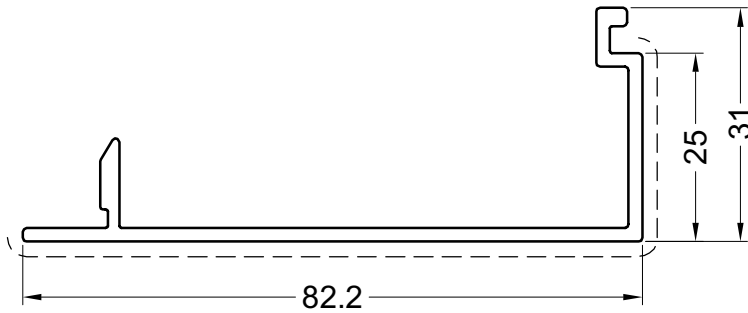

X
 Y---Y
 X
 lx = 19.03 cm⁴
 ly = 1.91 cm⁴
 Wx = 3.90 cm³
 Wy = 0.78 cm³

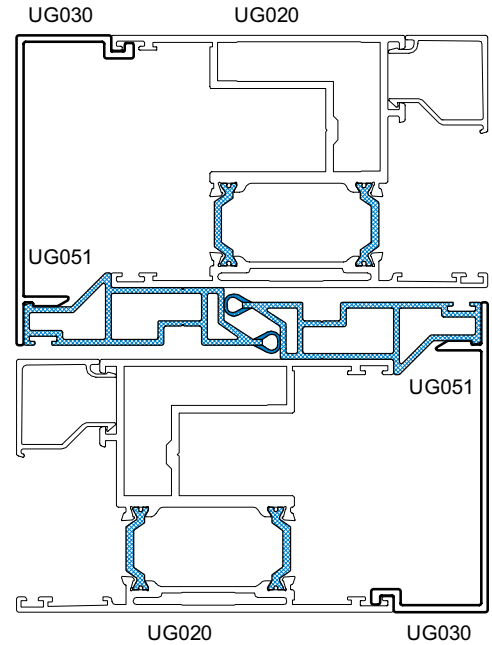

UG031

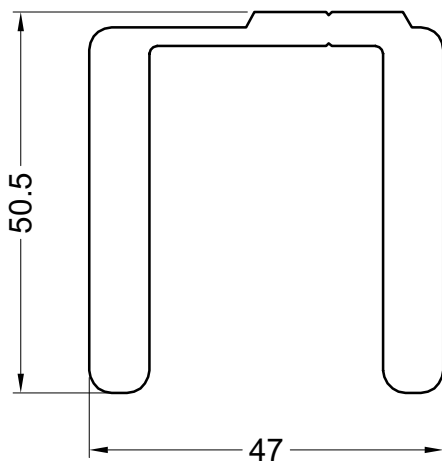

X
 Y---Y
 X
 lx = 30.47 cm⁴
 ly = 20.36 cm⁴
 Wx = 12.76 cm³
 Wy = 7.39 cm³

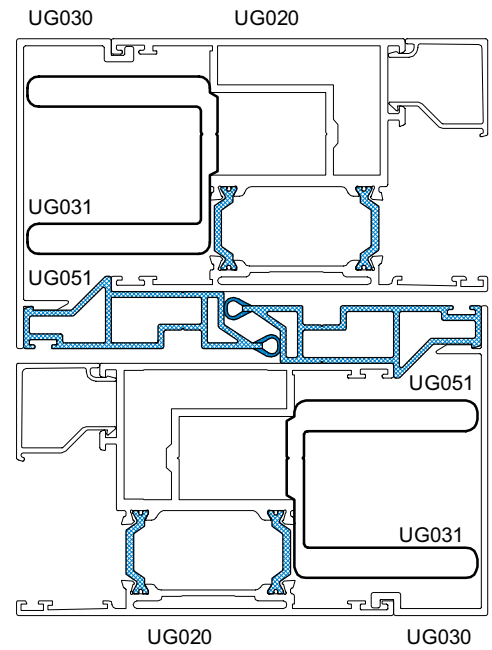

PROFIELEN - PROFILS - PROFILE - PROFILES

DREMPELPROFIELEN
 PROFILS DE SEUIL
 SCHWELLE
 SILLS

UG014

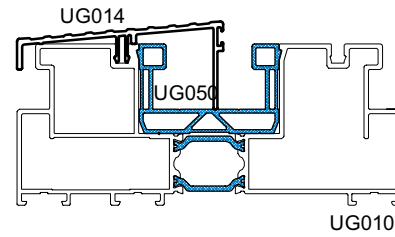
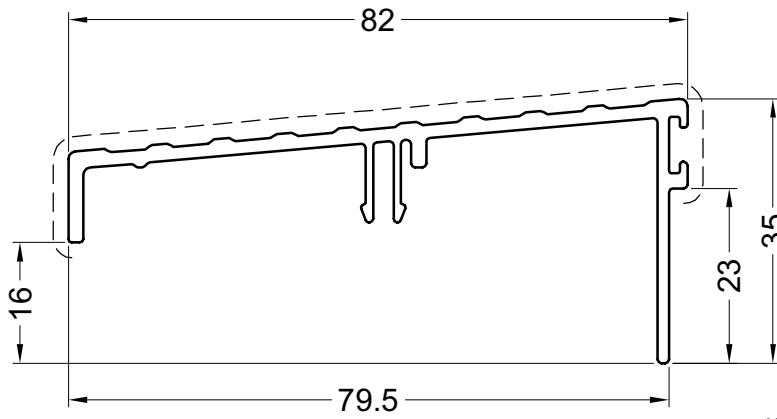

$I_x = 20.34 \text{ cm}^4$
 $I_y = 1.38 \text{ cm}^4$
 $W_x = 4.39 \text{ cm}^3$
 $W_y = 0.52 \text{ cm}^3$



UG015

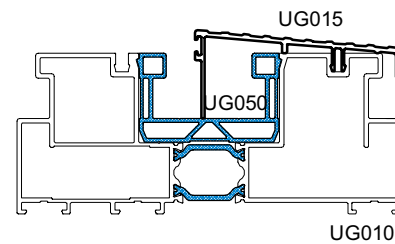
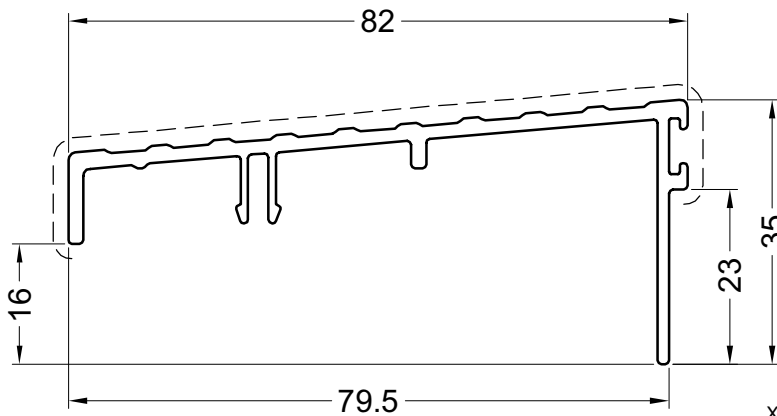

$I_x = 21.14 \text{ cm}^4$
 $I_y = 1.37 \text{ cm}^4$
 $W_x = 4.68 \text{ cm}^3$
 $W_y = 0.52 \text{ cm}^3$



UG614

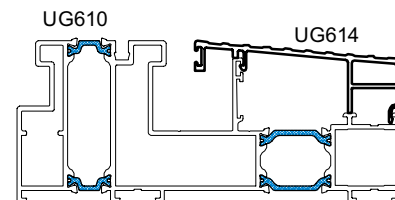
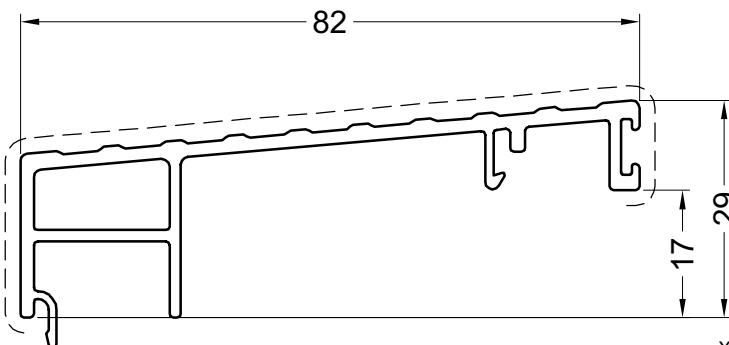

$I_x = 23.29 \text{ cm}^4$
 $I_y = 1.80 \text{ cm}^4$
 $W_x = 4.90 \text{ cm}^3$
 $W_y = 0.79 \text{ cm}^3$



pag06

KOPPELPROFIEL
COUPLAGE
KUPPLUNG
COUPLING MULLION

UG150

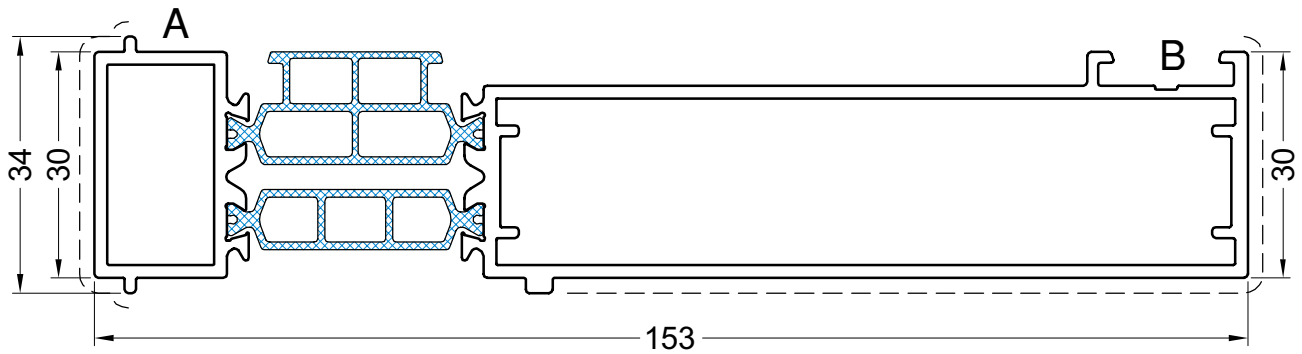

X
Y
X
Y

$I_x = 176.25 \text{ cm}^4$
 $I_y = 8.03 \text{ cm}^4$
 $W_x = 23.02 \text{ cm}^3$
 $W_y = 4.36 \text{ cm}^3$

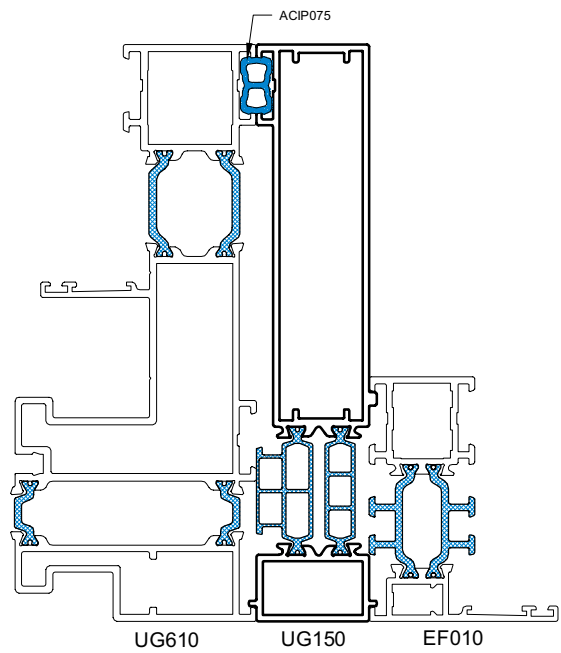
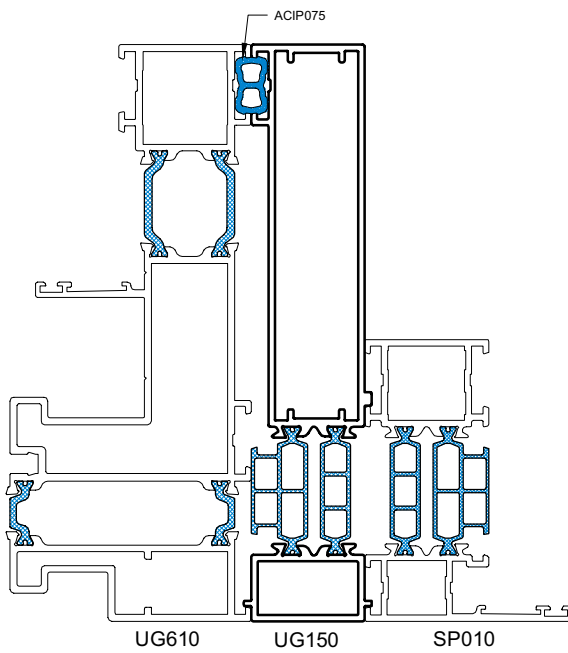

PROFIELEN - PROFILS - PROFILE - PROFILES

U-PROFIEL
PROFIL EN U
U-PROFILE
U-BAR

UTL029

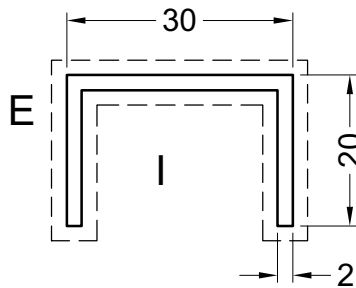

GLASLATTEN
LATTES A VITRAGE
GLASLEISTE
GLAZING BEADS

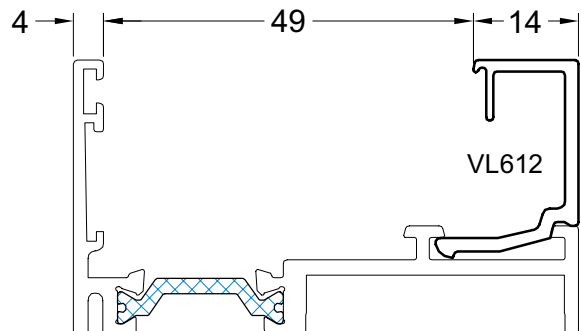
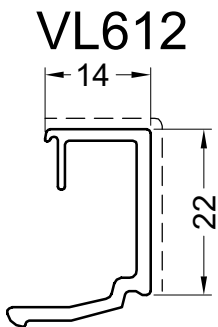
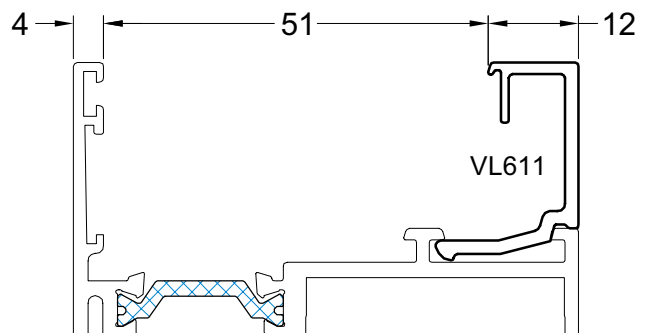
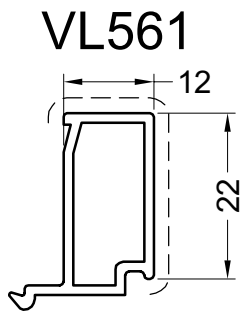
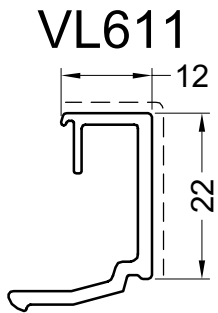
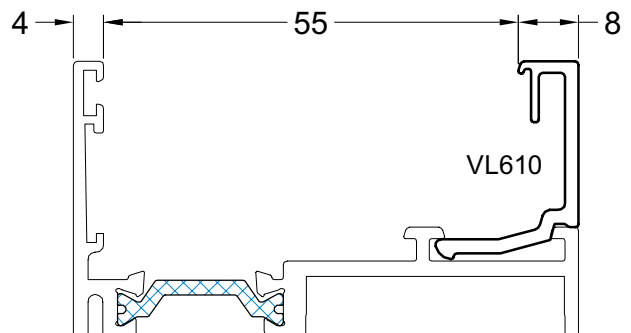
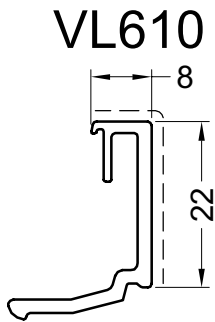
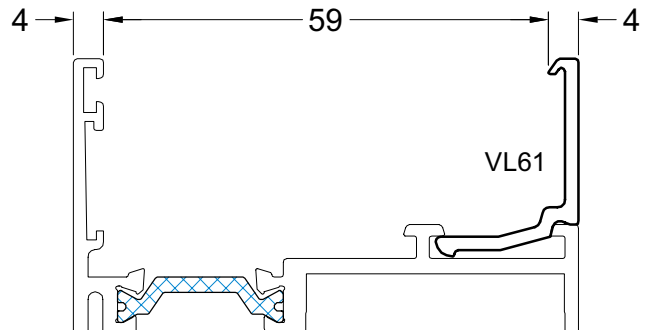
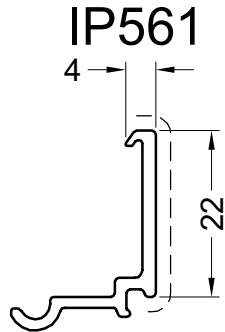
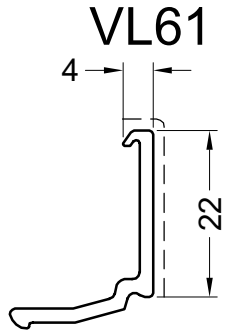

PROFIELEN - PROFILS - PROFILE - PROFILES

pag07

GLASLATTEN
LATTES A VITRAGE
GLASLEISTE
GLAZING BEADS

VL62

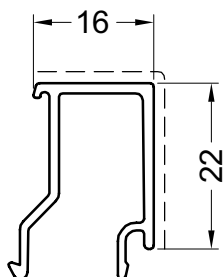

VL562

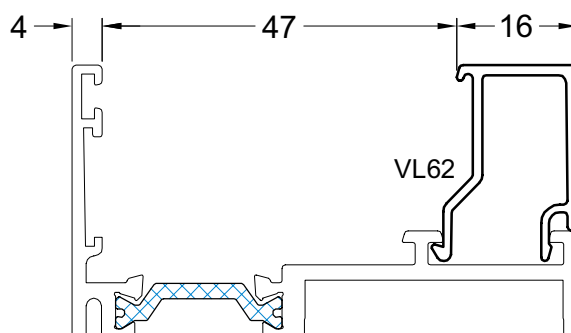
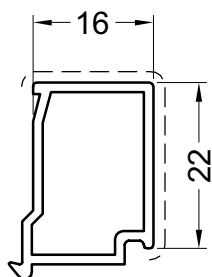

VL63

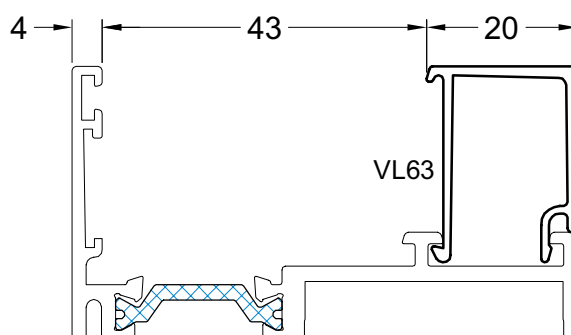
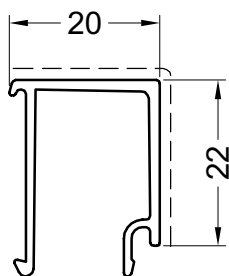

IP566

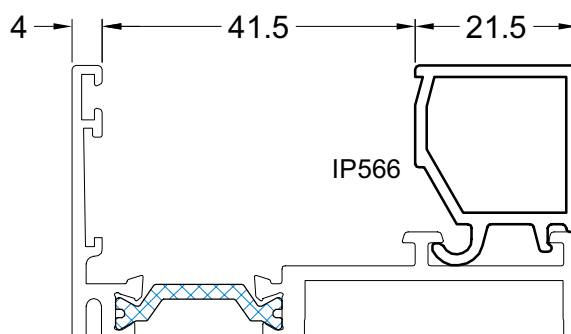
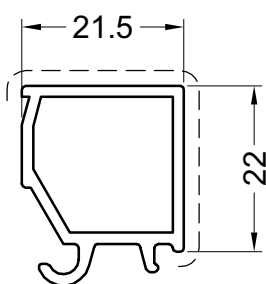

VL630

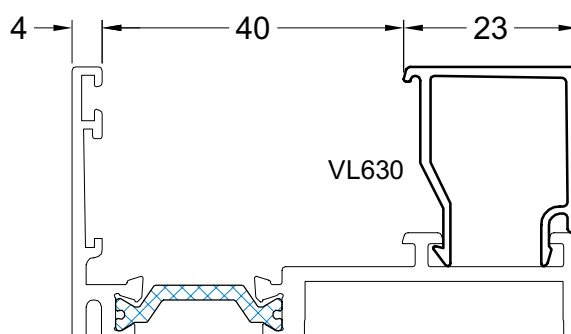
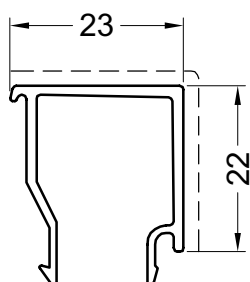

pag08

Primaire zichtbare zijde
Face visible primaire

Secundaire zichtbare zijde
Face visible secondaire

GLASLATTEN
LATTES A VITRAGE
GLASLEISTE
GLAZING BEADS

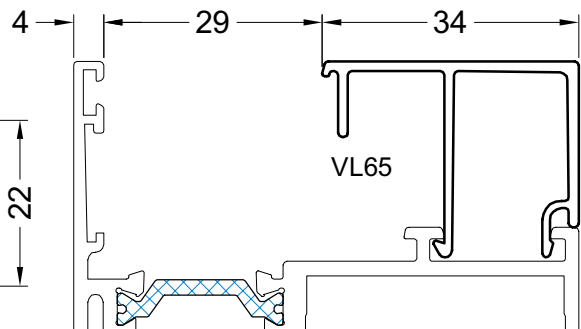
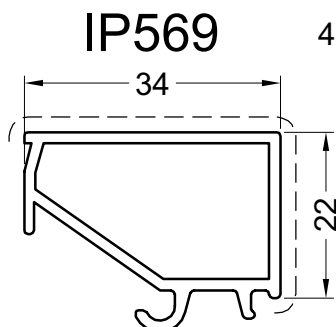
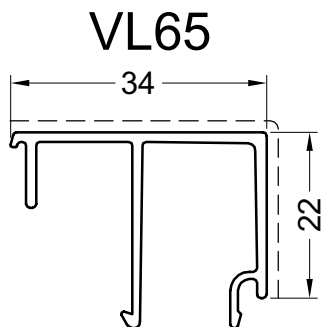
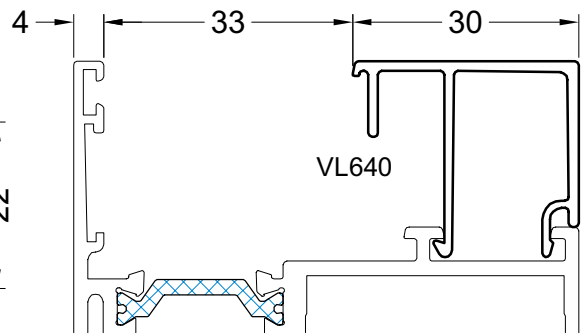
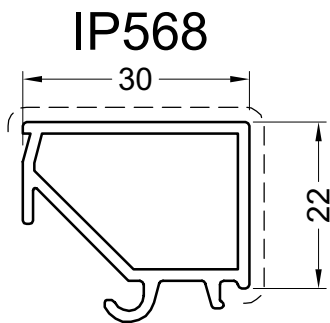
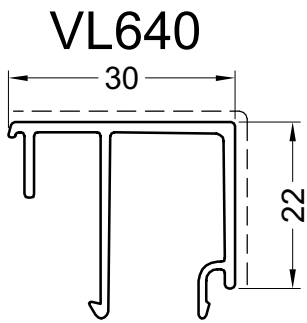
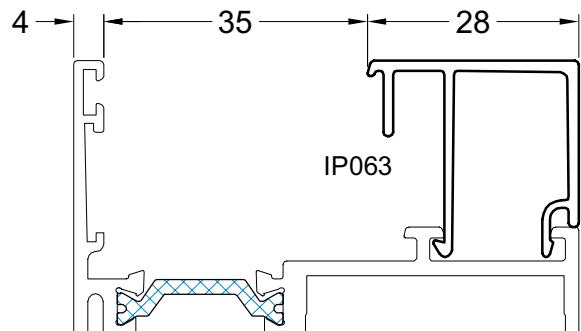
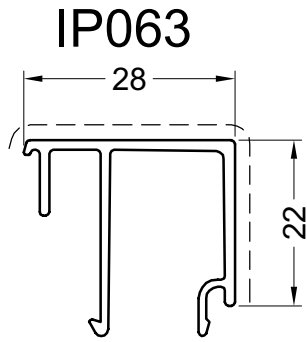
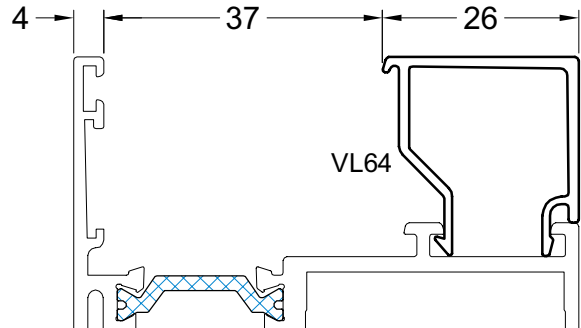
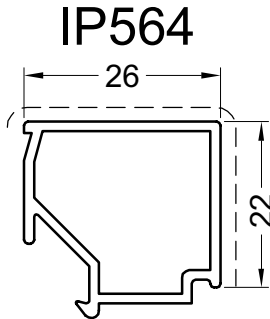
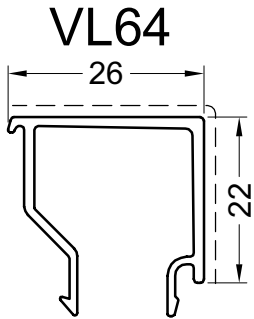

PROFIELEN - PROFILS - PROFILE - PROFILES

pag09

GLASLATTEN
LATTES A VITRAGE
GLASLEISTE
GLAZING BEADS

SP065

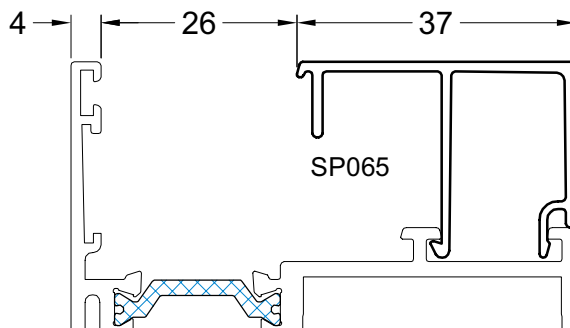
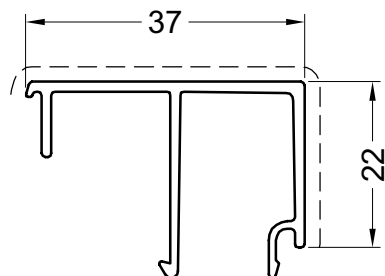

IP064

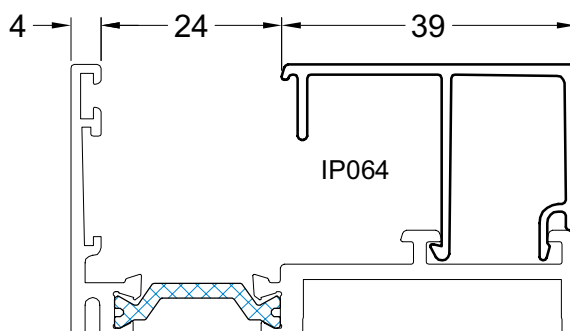
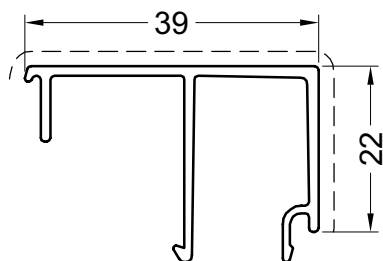

SP066

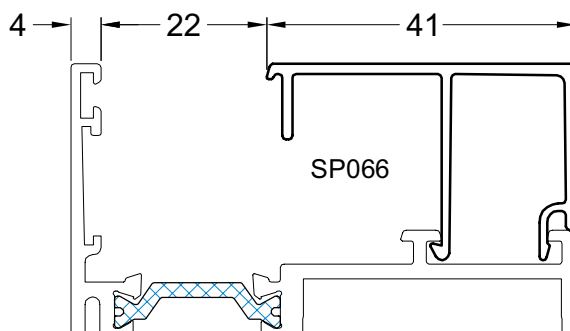
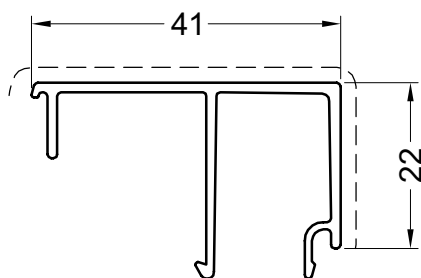

SP067

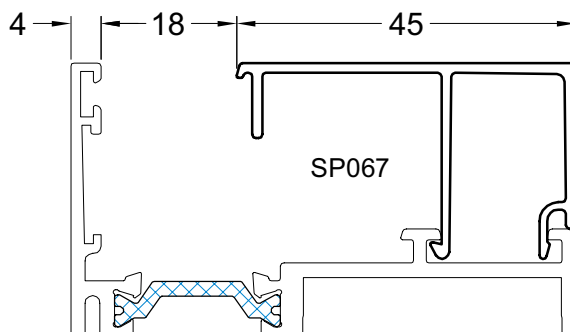
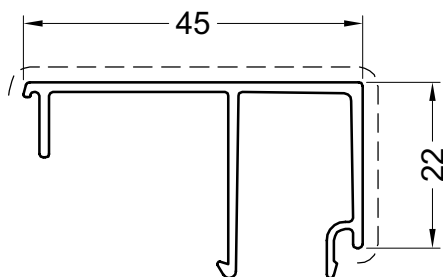

GLASLATTEN
LATTES A VITRAGE
GLASLEISTE
GLAZING BEADS

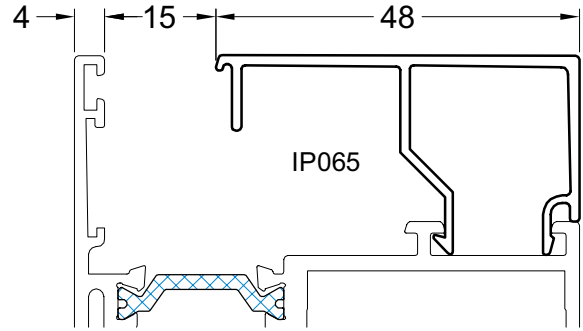
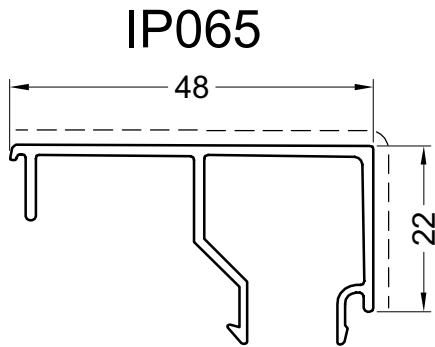

PROFIELEN - PROFILS - PROFILE - PROFILES

ROLLUIKPROFIELEN
 PROFILS VOLET
 ROLLADEN PROFILE
 SHUTTER PROFILES

VL70

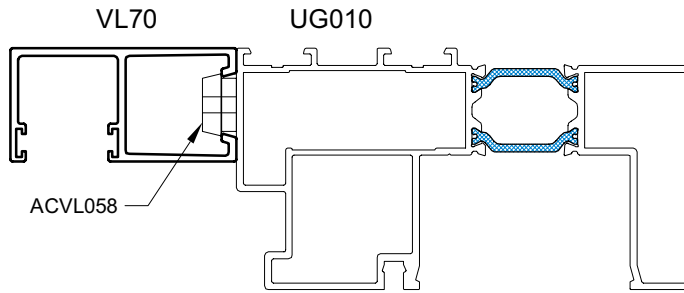
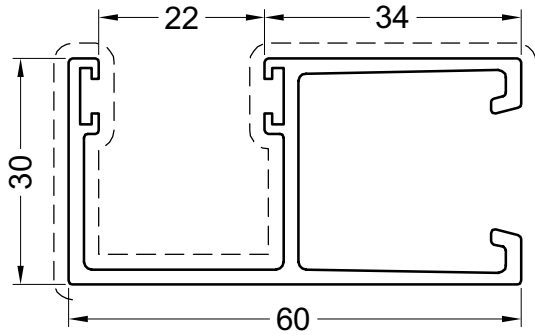

VL71

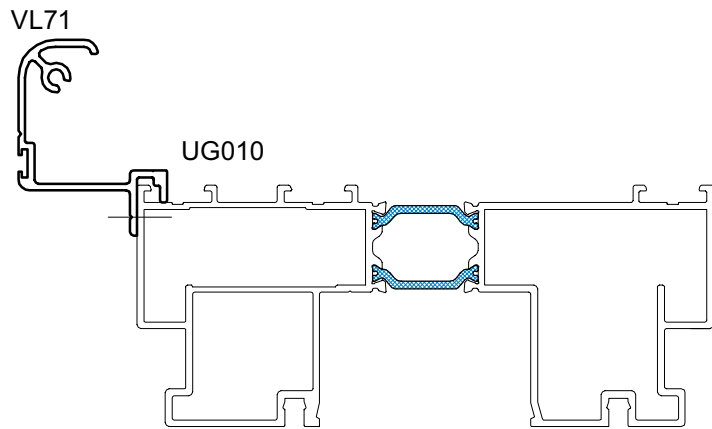
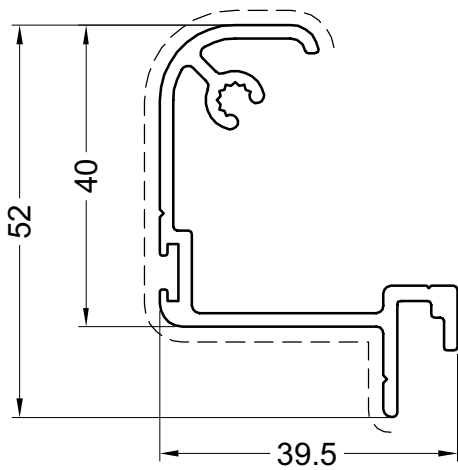

VL170

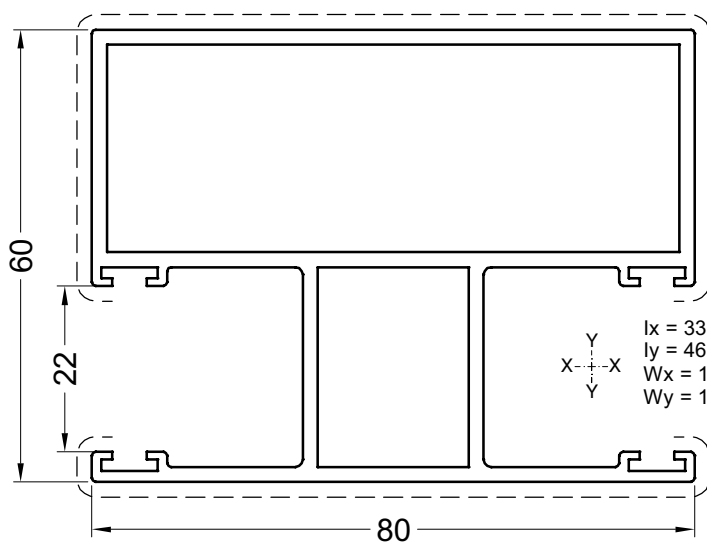

$I_x = 33.33 \text{ cm}^4$
 $I_y = 46.87 \text{ cm}^4$
 $W_x = 10.93 \text{ cm}^3$
 $W_y = 11.72 \text{ cm}^3$

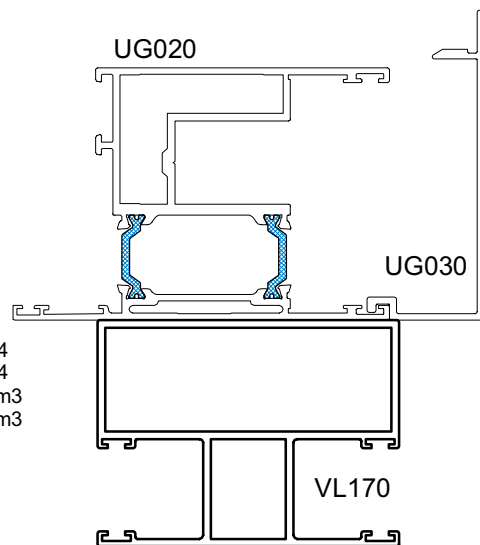

ROLPROFIEL

Primaire zichtbare zijde
 Face visible primaire

Secundaire zichtbare zijde
 Face visible secondaire

ROLLUIKPROFIELEN
 PROFILS VOLET
 ROLLADEN PROFILE
 SHUTTER PROFILES

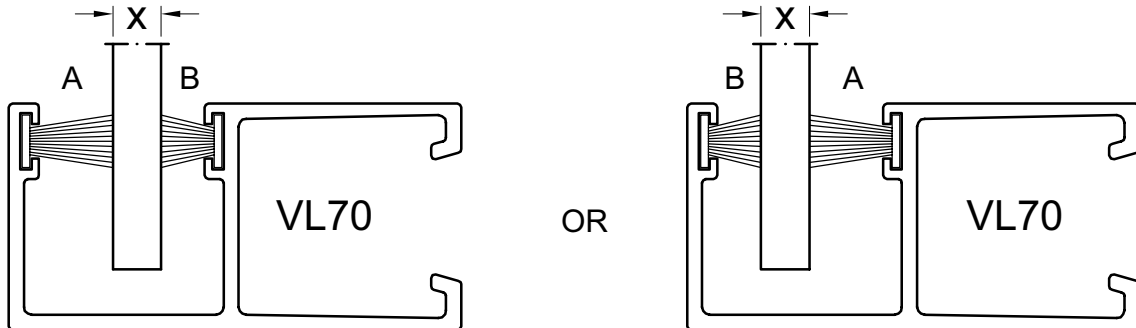

X	A	B
6 → 8	ACSR011	ACSR011
8 → 12	ACSR011	ACVL033
12 → 14	ACSR011	ACVG42
14 → 15	ACVL033	ACVL033
15 → 17	ACVL033	ACVG42
17 → 18	ACVG42	ACVG42

VL171

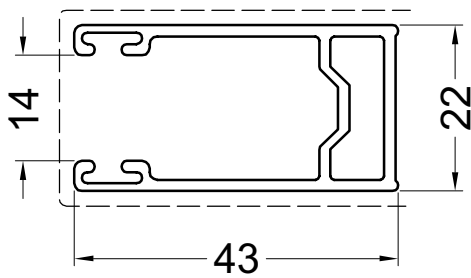

VL172

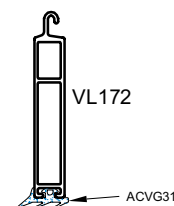
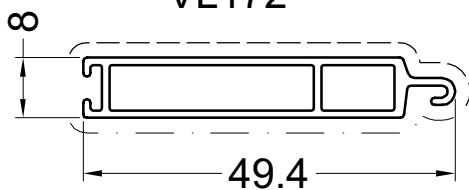

PROFIELEN - PROFILS - PROFILE - PROFILES

ROLTABEL

Primaire zichtbare zijde
 Face visible primaire

Secundaire zichtbare zijde
 Face visible secondaire

AANSLUITPROFIELEN
 PROFILS POUR CHAMBRANLES
 ANSCHLIESPROFILE
 CASING PROFILES

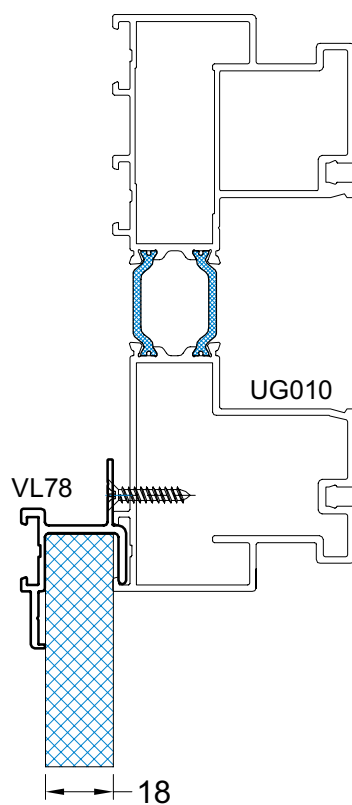
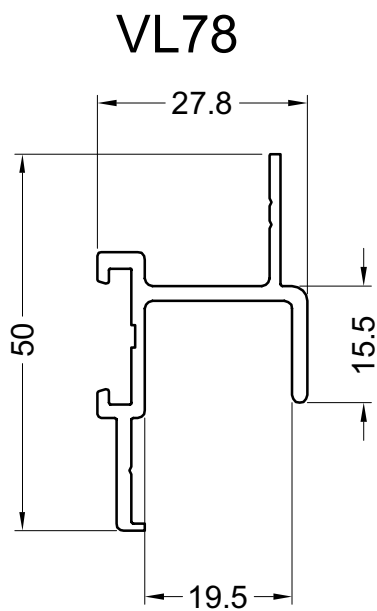
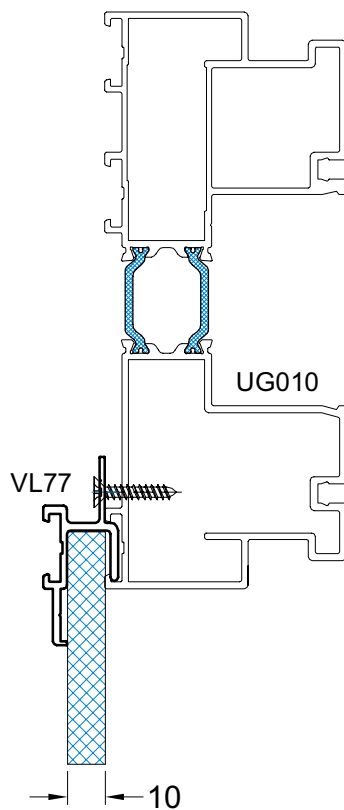
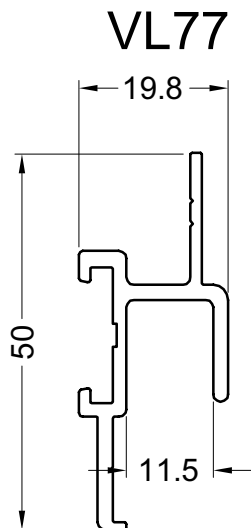

DIVERSE PROFIELEN
 PROFILS DIVERS
 DIVERS PROFILS
 VARIED PROFILES

UG050

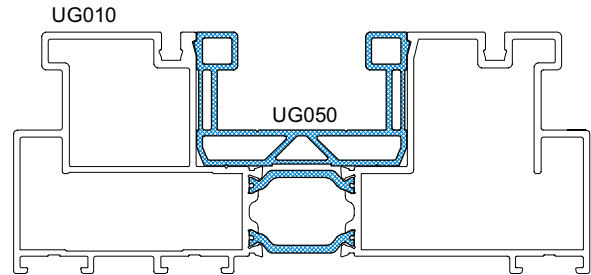
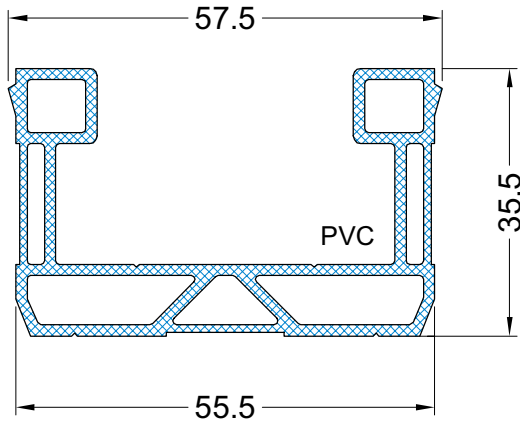

UG051

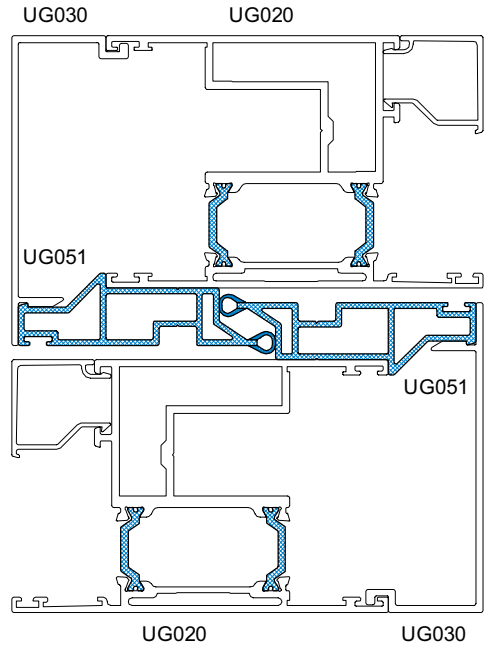
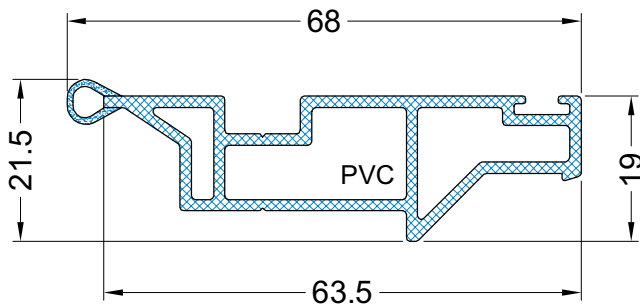

VG52

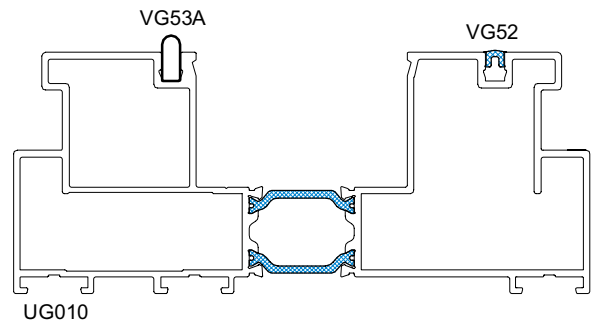
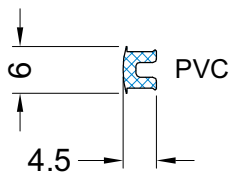

VG53

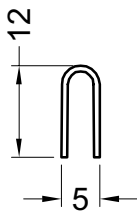



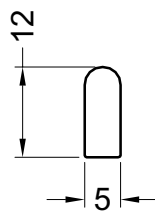







VG53A









PROFIELEN - PROFILS - PROFILE - PROFILES



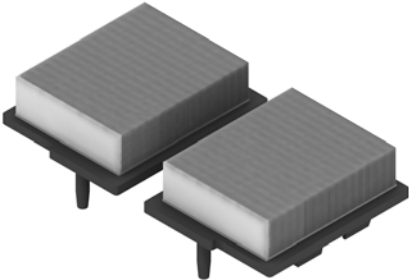
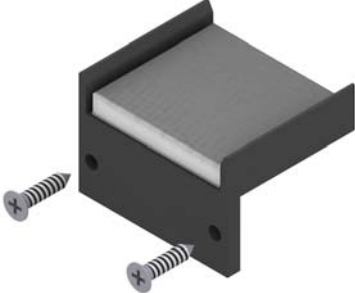

pag12

		Toepassing Application Anwendung Application	Verp. per Emb. par Pack pr. Pack pr.
	ACUG012	UG020	1
	-Pershoek voor binnenste kamer -Clame à presser pour chambre intérieure -Eckverbinder stanzbar für innere Kammer -Clamping corner for inside chamber		
	ACUG013	UG020	1
	-Schroefhoek voor binnenste kamer -Clame à visser pour chambre intérieure -Eckverbinder schraubbar für innere Kammer -Square coupling joint for inside chamber		
	ACUG014	UG010 UG011 UG012 UG013 UG110 UG111 UG112 UG113	1
	-Pershoek voor buiten- en binnenkamer -Clame à presser pour chambre intérieure et extérieure -Eckverbinder stanzbar für aussere und innere Kammer -Clamping corner for outside and inside chamber		
	ACUG015	UG010 UG011 UG012 UG013 UG110 UG111 UG112 UG113	1
	-Schroefhoek voor buiten- en binnenkamer -Clame à visser pour chambre intérieure et extérieure -Eckverbinder schraubbar für aussere und innere Kammer -Square coupling joint for outside and inside chamber		
	ACUG016	UG011 UG013 UG111 UG113	1
	-Pershoek voor middenkamer -Clame à presser pour chambre central -Eckverbinder stanzbar für zentral Kammer -Clamping corner for central chamber		

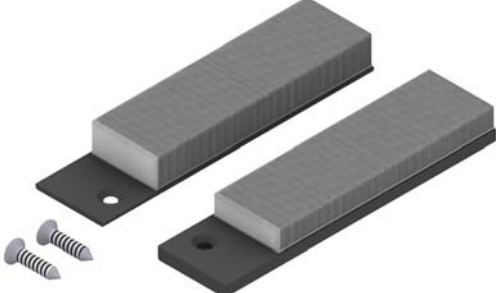
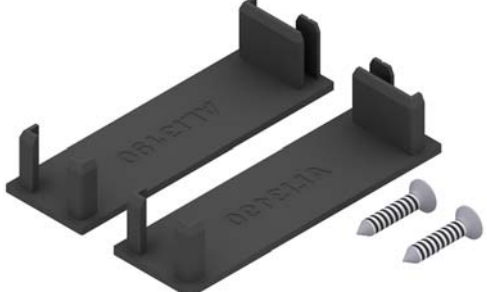
		Toepassing Application Anwendung Application	Verp. per Emb. par Pack pr. Pack pr.
	ACUG017 -Schroefhoek voor middenkamer -Clame à visser pour chambre central -Eckverbinder schraubbar für zentral Kammer -Square coupling joint for central chamber	UG011 UG013 UG111 UG113	1
	ACUG018 -Pershoek voor buitenste kamer -Clame à presser pour chambre extérieure -Eckverbinder stanbar für aussere Kammer -Clamping corner for outside chamber	UG011 UG013 UG111 UG113 UG610 UG612	1
	ACUG019 -Schroefhoek voor buitenste kamer -Clame à visser pour chambre extérieure -Eckverbinder schraubbar für aussere Kammer -Square coupling joint for outside chamber	UG011 UG013 UG111 UG113 UG610 UG612	1
	ACUG020 -Pershoek voor binnenste kamer -Clame à presser pour chambre intérieure -Eckverbinder stanbar für innere Kammer -Clamping corner for inside chamber	UG610 UG612	1
	ACUG021 -Schroefhoek voor binnenste kamer -Clame à visser pour chambre intérieure -Eckverbinder schraubbar für innere Kammer -Square coupling joint for inside chamber	UG610 UG612	1

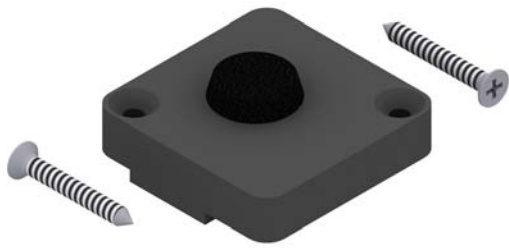
		Toepassing Application Anwendung Application	Verp. per Emb. par Pack pr. Pack pr.
	ACUG022	UG610 UG612	1
	-Pershoek voor middenkamer -Clame à presser pour chambre central -Eckverbinder stanzzbar für zentral Kammer -Clamping corner for central chamber		
	ACUG023	UG610 UG612	1
	-Schroefhoek voor middenkamer -Clame à visser pour chambre central -Eckverbinder schraubbar für zentral Kammer -Square coupling joint for central chamber		
	ACUG024	UG610 UG612 UG020	1
	-T-verbinding -Assemblage-T -T-verbinder -Connecting bracket		
	ACUG025	UG610 UG612 UG020	1
	-T-verbinding -Assemblage-T -T-verbinder -Connecting bracket		
	ACUG026	UG016	1
	-Lijmhoek voor binnenste kamer -Equerre de colle pour chambre intérieure -Eckverstärkung für innere Kammer -Glue square for inside chamber		

		Toepassing Application Anwendung Application	Verp. per Emb. par Pack pr. Pack pr.
	<p>ACUG028</p> <ul style="list-style-type: none"> -Centrale dichting -Etanchéité centrale -Mitteldichtung -Plug for risers and antidust 	UG140	1
	<p>ACUG029</p> <ul style="list-style-type: none"> -Centreerstukje -Centre piece -Zentrier Stuck -Center piece 	UG020	1
	<p>ACUG030</p> <ul style="list-style-type: none"> -Centrale dichting onder en boven -Etanchéité centrale inférieure et supérieure -Mitteldichtung unten und oben -Plug for risers and antidust up and down 	UG010 UG011	1
	<p>ACUG031</p> <ul style="list-style-type: none"> -Centrale dichting onder en boven -Etanchéité centrale inférieure et supérieure -Mitteldichtung unten und oben -Plug for risers and antidust up and down 	UG016	1
	<p>ACUG032</p> <ul style="list-style-type: none"> -Eindstuk -Embout -Endstück -End piece 	UG016 UG030 UG051	1

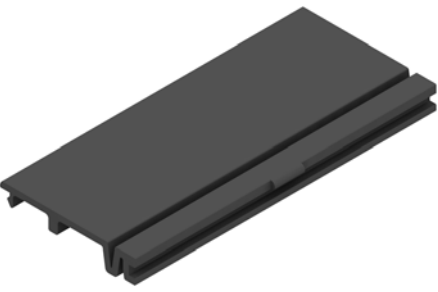
		Toepassing Application Anwendung Application	Verp. per Emb. par Pack pr. Pack pr.
	<p>ACUG040</p> <ul style="list-style-type: none"> -Sluitstootbuffer -Butee de fermeture -Stossklotz -Stop block 	<p>UG610 UG612 UG020</p>	<p>1</p>
	<p>ACUG042</p> <ul style="list-style-type: none"> -Afdichtingsrubber -Joint d'étanchéité -Dichtungsgummi -Weathering gasket 		<p>1</p>
	<p>ACUG044</p> <ul style="list-style-type: none"> -Vleugelsteun -Support de vantail -Flügelunterstützung -Vent support 		<p>1</p>
	<p>ACUG048</p> <ul style="list-style-type: none"> -Stootbuffer -Butée -Buffer -Stopper 		<p>1</p>
	<p>ACUG057</p> <ul style="list-style-type: none"> -Glassteun -Support cale de vitrage -Klotz-auflage -Glazing support 		<p>1</p>

Toepassing
Application
Anwendung
Application

Verp. per
Emb. par
Pack pr.
Pack pr.

ACUG060

100M

- Zelfklevende isolatie strip
- Autocollante isolation barre
- Selbstklebend isolation strip
- Self adhesive insulation strip



9 X 10

ACUG061

100M

- Zelfklevende isolatie strip
- Autocollante isolation barre
- Selbstklebend isolation strip
- Self adhesive insulation strip



21.5 X 10

ACUG062

100M

- Zelfklevende isolatie strip
- Autocollante isolation barre
- Selbstklebend isolation strip
- Self adhesive insulation strip



53 X 50

ACUG110

1

- Inox tandemwiel
- Roulette en inox
- Inox tandemrolle
- Double pulley en inox



ACUG120

1

- Sluitstuk raildoorgang
- Closoir passage rail
- Abdeckkappe
- Central plug

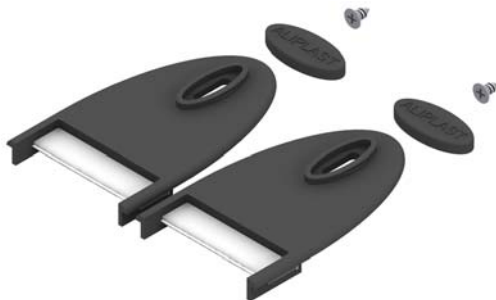

Toepassing	Verp. per
Application	Emb. par
Anwendung	Pack pr.
Application	Pack pr.

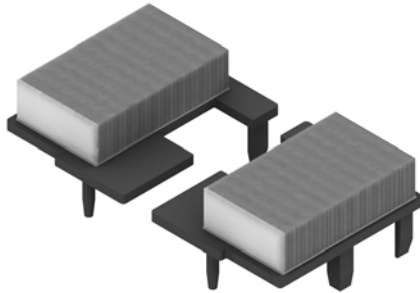

ACUGI28

UG141

1

- Centrale dichting
- Etanchéité centrale
- Mitteldichtung
- Plug for risers and antidust



ACUGI30

1

- Centrale dichting onder en boven hefschuif
- Etanchéité centrale inférieure et supérieure coulissant levant
- Mitteldichtung unten und oben hebeschiebe
- Plug for risers and antidust up and down lift sliding

ACUG200

1

-Slotoverbrenging
-Transmission de serrure
-Getriebe
-Espag

1343mm < Hv < 1942mm

ACUG201

1

-Slotoverbrenging
-Transmission de serrure
-Getriebe
-Espag

1943mm < Hv < 2242mm

ACUG202

1

-Slotoverbrenging
-Transmission de serrure
-Getriebe
-Espag

2243mm < Hv < 2542mm

ACUG203

1

-Slotoverbrenging
-Transmission de serrure
-Getriebe
-Espag

2543mm < Hv < 2842mm

Toepassing
Application
Anwendung
Application

Verp. per
Emb. par
Pack pr.
Pack pr.

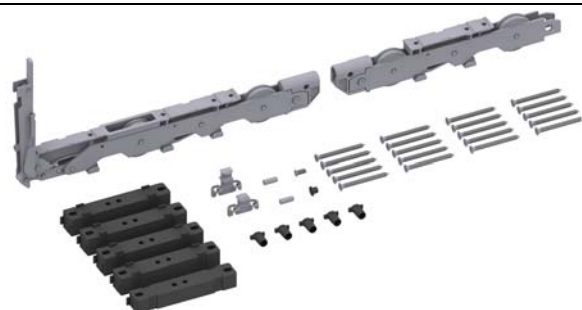

ACUG210

1

- Basispakket hefschuif vleugel
- Paquet de base pour porte à levage
- Grundkarton für Hebe-Schiebe flügel
- Basic set lift slide vent



ACUG220

1

- Aanvullend sluitpunt
- Point de fermeture supplémentaire
- Zusätzlicher Schliesspunkt
- Additional locking point



ACUG221

1

- Sluitpunt 4 vleugels
- Point de fermeture 4 vantaux
- Schliesspunkt 4 Flügel
- Locking point 4 vents



ACUG230

1

- Verbindingsstaaf
- Barre de connection
- Verbindungsstab
- Connecting plate

894mm < Bv < 1574mm



ACUG231

1

- Verbindingsstaaf
- Barre de connection
- Verbindungsstab
- Connecting plate

1575mm < Bv < 2074mm

**ACUG232**

- Verbindingsstaaf
- Barre de connection
- Verbindungsstab
- Connecting plate

2075mm < Bv < 2574mm

1

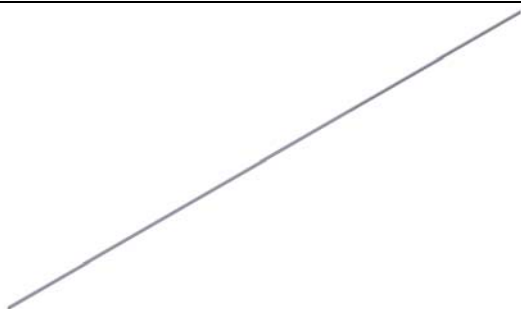
**ACUG233**

- Verbindingsstaaf
- Barre de connection
- Verbindungsstab
- Connecting plate

2464mm < Bv < 3314mm

1

**ACUG282**

- Schroef M5 X 70
- Vis M5 X 70
- Schraube M5 X 70
- Screws M5 X 70

1

**ACUG283**

- Tubtara voor slot
- Tubtara pour serrure
- Gewindebuchsen für Getriebe
- Threaded bushes for espag

1





**ACUG284**

- Kongreep buiten
- Cuvette extérieur
- Griffschale aussen
- Integrated handle outside

1

Toepassing
Application
Anwendung
Application

Verp. per
Emb. par
Pack pr.
Pack pr.

	<p>ACUG285</p> <ul style="list-style-type: none"> -Enkele draaigreep voor hefschuifdeur binnen -Poignée simple pour levant coulissant intérieur -Drehgriff für hebeschiebetür innen -Single turn handle for lift sliding patio door inside 	1
	<p>ACUG286</p> <ul style="list-style-type: none"> -Dubbele draaigreep voor hefschuifdeur -Poignée double pour levant coulissant -Drehgriff beidseitig für hebeschiebetür -Double turn handle for lift sliding patio door 	1
	<p>ACUG287</p> <ul style="list-style-type: none"> -Enkele draaigreep voor hefschuifdeur met cilindergat -Poignée simple pour levant coulissant avec cylindre -Drehgriff für hebeschiebetür mit Zylinder -Single turn handle for lift sliding patio door with cylinder hole 	1
	<p>ACUG288</p> <ul style="list-style-type: none"> -Handgreep set binnen -Poignée set intérieur -Griffgarnitur innen -Handle set inside 	1
	<p>ACUG289</p> <ul style="list-style-type: none"> -Handgreep set met cilindergat -Poignée set avec cylindre -Griffgarnitur mit Zylinder -Handle set with cylinder 	1

Toepassing
Application
Anwendung
Application

Verp. per
Emb. par
Pack pr.
Pack pr.

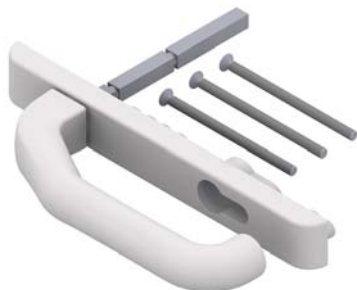

ACUG553

ACVG551

1

- Buitenruk met stift 136mm inbraakvertragend
- Poignée extérieure avec tige 136mm anti effraction
- Krücke aussen mit stift 136mm einbruchhemmend
- Handle outside with pin 136mm burglary proof

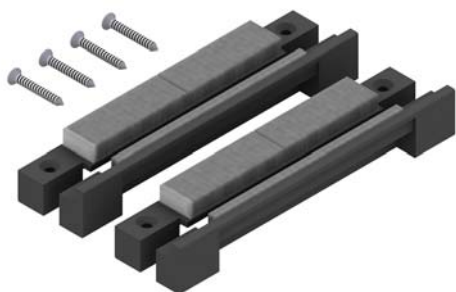

ACUG630

1

- Centrale dichting onder en boven monorail
- Etanchéité centrale inférieure et supérieure monorail
- Mitteldichtung unten und oben monorail
- Plug for risers and antidust up and down monorail



ACUG730

1

- Centrale dichting onder en boven monorail hefschuif
- Etanchéité centrale inférieure et supérieure monorail coulissant levant
- Mitteldichtung unten und oben monorail hebeschiebe
- Plug for risers and antidust up and down monorail lift sliding



ACUG746

ACUG749
ACVG551
ACVG751

1

- Ondervulling voor slot
- Support pour serrure
- Stütze für Schloss
- Support for lock



ACUG747

ACUG749
ACVG551
ACVG751

1

- Ondervulling voor slot
- Support pour serrure
- Stütze für Schloss
- Support for lock

	Toeassing Application Anwendung Application	Verp. per Emb. par Pack pr. Pack pr.
	ACUG748 -Slotplaat -Gäche -Schliessplatte -Lock plate	ACUG749 1
		H=2970mm

Toepassing
Application
Anwendung
Application

Verp. per
Emb. par
Pack pr.
Pack pr.





ACUG749



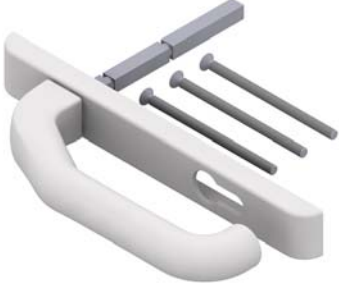

1

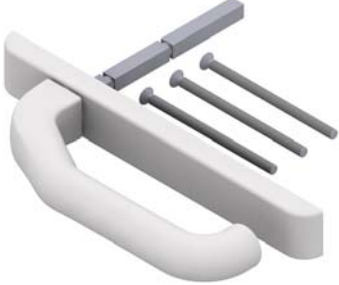
- Meerpuntsluiting 5p.
- Fermeture multi-points 5p.
- Multipunkte Verschluss 5p.
- Multiple point lock 5p.

H=2370mm

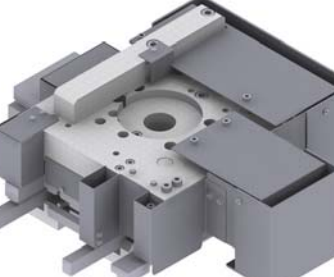

		Toepassing Application Anwendung Application	Verp. per Emb. par Pack pr. Pack pr.
	ACUG753 -Buitenkruk met stift 136mm -Poignée extérieure avec tige 136mm -Handgriff aussen mit Stift 136mm -Outside handle with pin 136mm	ACUG749 ACVG751	1
	ACUG755 -Rolluikkruk met stift 118mm -Poignée volet avec tige 118mm -Handgriff Rolladen mit Stift 118mm -Handle shutter with pin 118mm	ACUG749 ACVG751	1
	ACUG756 -Stift 70mm -Tige 70mm -Stift 70mm -Pin 70mm	ACVG754	1
	ACUG757 -Buitenkruk met stift 136mm zonder cilindergat -Poignée extérieure avec tige 136mm sans trou de cylindre -Handgriff aussen mit Stift 136mm ohne Zylinderloch -Outside handle with pin 136mm without cylinder gap	ACUG749 ACVG751	1
	ACUG759 -Rolluikkruk met stift 118mm zonder cilindergat -Poignée volet avec tige 118mm sans trou de cylindre -Handgriff Rolladen mit Stift 118mm ohne Zylinderloch -Handle shutter with pin 118mm without cylinder gap	ACUG749 ACVG751	1

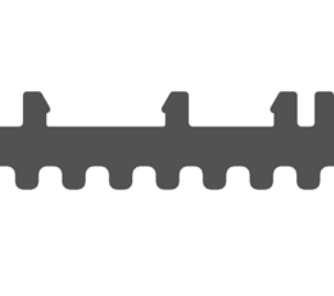
		Toepassing Application Anwendung	Verp. per Emb. par Pack pr. Pack pr.
	<p>ACUG760</p> <ul style="list-style-type: none"> -Verkorte buitenkruk met stift 128mm met cilinder gat -Poignée extérieure raccourc avec tige 128mm avec trou de cylindre -Kürzend Krücke aussen mit Stift 128mm mit Zylinder loch -Shortened handle outside with pin 128mm with cylinder gap 	ACUG749 ACVG751	1
	<p>ACUG761</p> <ul style="list-style-type: none"> -Verkorte buitenkruk met stift 128mm zonder cilinder gat -Poignée extérieure raccourc avec tige 128mm sans trou de cylindre -Kürzend Krücke aussen mit Stift 128mm ohne Zylinder loch -Shortened handle outside with pin 128mm without cylinder gap 	ACUG749 ACVG751	1
	<p>ACUG900</p> <ul style="list-style-type: none"> -Pneumatische matrijs -Poinconneuse pneumatique -Stanzwerkzeug -Punch tool 		1
	<p>ACUG950</p> <ul style="list-style-type: none"> -Boormal -Gabarit de perçage -Bohrer mall -Boring jig 		1
	<p>ACEF300</p> <ul style="list-style-type: none"> -Basis rubber -Base gache -Basis Gummi -Base rubber 		25M

Toepassing
Application
Anwendung
Application

Verp. per
Emb. par
Pack pr.
Pack pr.

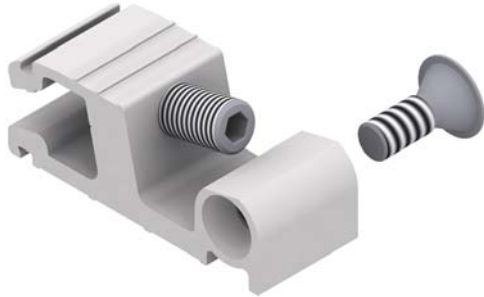

ACIP025B

UG025

1

- T-verbinding voor binnenste kamer
- Assemblage-T pour chambre intérieure
- T-verbinder für innere Kammer
- Connecting bracket for inside chamber



ACIP026B

UG026

1

- T-verbinding voor binnenste kamer
- Assemblage-T pour chambre intérieure
- T-verbinder für innere Kammer
- Connecting bracket for inside chamber



ACIP027B

UG027

1

- T-verbinding voor binnenste kamer
- Assemblage-T pour chambre intérieure
- T-verbinder für innere Kammer
- Connecting bracket for inside chamber



ACIP075

50M

- Koppelrubber
- Gache couplage
- Küplung gummi
- Coupling gasket



ACIP300

25M

- Basis rubber
- Base gache
- Basis Gummi
- Base rubber

Toepassing
Application
Anwendung
Application

Verp. per
Emb. par
Pack pr.
Pack pr.



ACIP910

- Boormal voor T-verbinding
- Calibre pour assemblage T
- Bohrschablone für T-Verbindung
- Boring jet set for connection T

UG025
UG026
UG027

1



ACMX01603

- Halve cilinder 40
- Demi cylindre 40
- Halbzylinder 40
- Half cylinder 40

1



ACMX01621

- Cilinder 40/55
- Cylindre 40/55
- Zylinder 40/55
- Cylinder 40/55

1



ACMX09700

- Alu-polish
- Alu-polish
- Alu-polish
- Alu-polish

750ml

1

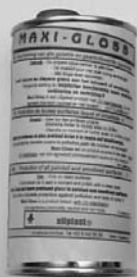

ACMX09761

- Maxi-gloss
- Maxi-gloss
- Maxi-gloss
- Maxi-gloss

500ml

1

Toepassing
Application
Anwendung
Application

Verp. per
Emb. par
Pack pr.
Pack pr.

	<p>ACMX09762</p> <ul style="list-style-type: none"> -Periodi-clean -Periodi-clean -Periodi-clean -Periodi-clean <p>500ml</p> <p style="text-align: right;">1</p>
	<p>ACMX09763</p> <ul style="list-style-type: none"> -Teflon spray -Teflon spray -Teflon spray -Teflon spray <p>400ml</p> <p style="text-align: right;">1</p>
	<p>ACMX09764</p> <ul style="list-style-type: none"> -Maxi-cleaner -Maxi-cleaner -Maxi-cleaner -Maxi-cleaner <p>500ml</p> <p style="text-align: right;">1</p>
	<p>ACMX09765</p> <ul style="list-style-type: none"> -Glue-cleaner -Glue-cleaner -Glue-cleaner -Glue-cleaner <p>500ml</p> <p style="text-align: right;">1</p>
	<p>ACMX09766</p> <ul style="list-style-type: none"> -Surface activator -Surface activator -Surface activator -Surface activator <p>1l</p> <p style="text-align: right;">1</p>

Toepassing
Application
Anwendung
Application

Verp. per
Emb. par
Pack pr.
Pack pr.



ACMX09767

-Anti-stone

opgepast voor natuursteen en metselwerk
attention pour pierre de taille et maçonnerie
achtung für Naturstein und Mauerwerk
attention for natural stone and bricklaying

500ml

1



ACMX09770

-Rol andywrap 100mm
-Rouleau andywrap 100mm
-Rolle andywrap 100mm
-Roll andywrap 100mm

150M

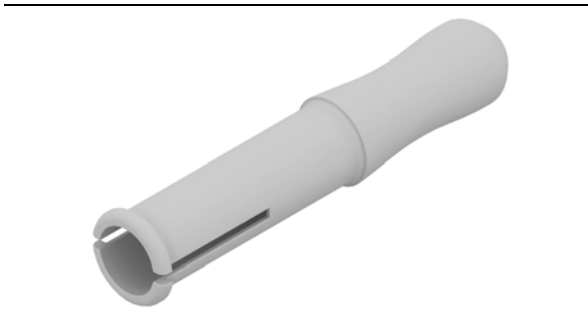

ACMX09775

-Houder andywrap
-Manche andywrap
-Halter andywrap
-Grip andywrap

1

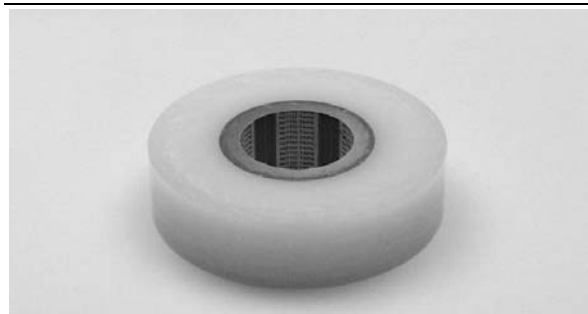

ACMX09801

-Beschermtape 50mm (500m)
-Tape de protection 50mm (500m)
-Schutz klebeband 50mm (500m)
-Protective tape 50mm (500m)

1

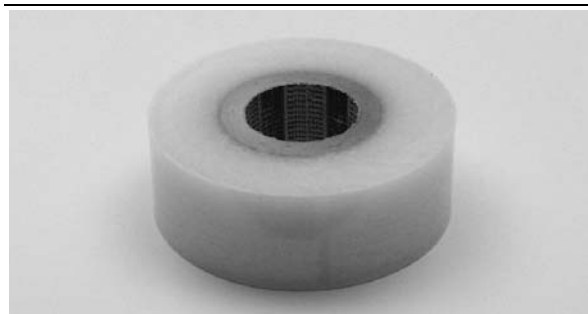

ACMX09802

-Beschermtape 70mm (500m)
-Tape de protection 70mm (500m)
-Schutz klebeband 70mm (500m)
-Protective tape 70mm (500m)

1

Toepassing
Application
Anwendung
Application

Verp. per
Emb. par
Pack pr.
Pack pr.

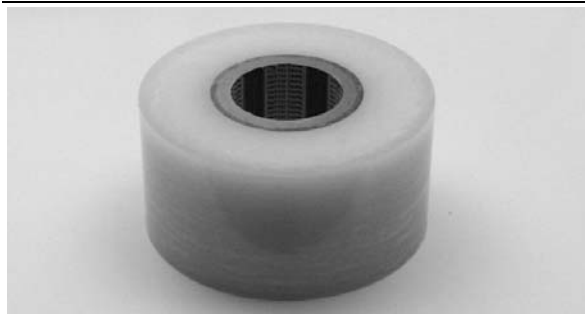

ACMX09803

1

- Beschermtape 100mm (500m)
- Tape de protection 100mm (500m)
- Schutz klebeband 100mm (500m)
- Protective tape 100mm (500m)

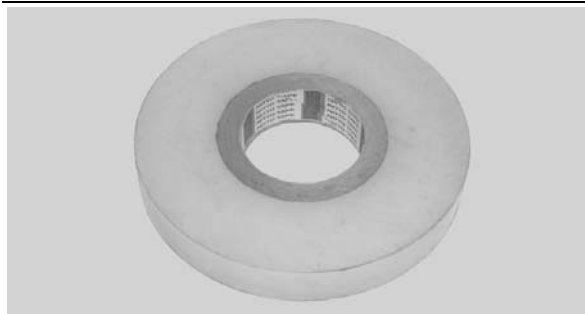

ACMX09804

1

- Beschermtape 35mm (500m)
- Tape de protection 35mm (500m)
- Schutz klebeband 35mm (500m)
- Protective tape 35mm (500m)



ACMX09830

1

- Kleefstof voor EPDM-rubbers
- Colle pour EPDM-caoutchouc
- Dichtmasse + klebstoff EPDM gummi
- Gum for EPDM-rubber



ACSG073

ACUG753
ACUG755
ACUG757
ACVG754

1

- Haakslot + slotplaat
- Serrure à crochet + gache
- Haakschloss + schliesplatte
- Hooklock + lock plate



ACSG080

ACUG749
ACVG551
ACVG751

1





- Bevestigingsplaat voor slot
- Plaques de fixation pour serrure
- Befestigungsplatte für Schloss
- Fixation plates for lock

		Toepassing Application Anwendung Application	Verp. per Emb. par Pack pr. Pack pr.
	<p>ACSG081</p> <ul style="list-style-type: none"> -Bevestigingsplaat voor slot -Plaque de fixation pour serrure -Befestigungsplatte für Schloss -Fixation plate for lock 	ACUG749 ACVG551 ACVG751	1
	<p>ACSIL04</p> <ul style="list-style-type: none"> -Afdichtingslijmkit voor versteknaden -Joint d'étanchéité pour onglets -Leim für abdichtung -Sealingglue 		1
	<p>ACSIL08</p> <ul style="list-style-type: none"> -Siliconenpomp -Pistolet doseur pour les tubes silicones -Handkartuschenpistole für die verarbeitung von silikon und leime -Silicone gun 		1
	<p>ACSIL013</p> <ul style="list-style-type: none"> -Lijm voor verstekhoek -Colle pour onglet -Kleber für gehrung -Glue for mitre 		1
	<p>ACSIL014</p> <ul style="list-style-type: none"> -Anticorro - beschermingsproduct -Anticorro - produit de protection -Anticorro - schutzprodukt -Anticorro - protection product <p>500ml</p>		1

Toepassing
Application
Anwendung
Application





Verp. per
Emb. par
Pack pr.
Pack pr.

	<p>ACSP031</p> <ul style="list-style-type: none"> -Beglazingsrubber buiten 3mm -Joint de vitrage extérieure 3mm -Glasanlage-Dichtung aussen 3mm -Glazing gasket outside 3mm 	100M
	<p>ACSP032</p> <ul style="list-style-type: none"> -Beglazingsrubber binnen 3mm -Joint de vitrage intérieur 3mm -Glasdichtung innen 3mm -Glazing gasket inside 3mm 	100M
	<p>ACSP033</p> <ul style="list-style-type: none"> -Beglazingsrubber binnen 4mm -Joint de vitrage intérieur 4mm -Glasdichtung innen 4mm -Glazing gasket inside 4mm 	100M
	<p>ACSP034</p> <ul style="list-style-type: none"> -Beglazingsrubber binnen 5mm -Joint de vitrage intérieur 5mm -Glasdichtung innen 5mm -Glazing gasket inside 5mm 	100M
	<p>ACSP340</p> <ul style="list-style-type: none"> -Beglazingsrubber binnen 6mm -Joint de vitrage intérieur 6mm -Glasdichtung innen 6mm -Glazing gasket inside 6mm 	100M

		Toepassing Application Anwendung Application	Verp. per Emb. par Pack pr. Pack pr.
	ACSR011 -Borstel 12mm -Brosse 12mm -Bürste 12mm -Brush 12mm	VL70	100M
	ACTL021A -Pershoek voor buitenste kamer -Clame à presser pour chambre extérieure -Eckverbinder Stanzbar für aussere Kammer -Clamping corner for outside chamber	UG020	1 48
	ACTL025A -T-verbinding voor buitenste kamer -Assemblage-T pour chambre extérieure -T-verbinder für aussere Kammer -Connecting bracket for outside chamber	UG025	1
	ACTL026A -T-verbinding voor buitenste kamer -Assemblage-T pour chambre extérieure -T-verbinder für aussere Kammer -Connecting bracket for outside chamber	UG026	1
	ACTL027A -T-verbinding voor buitenste kamer -Assemblage-T pour chambre extérieure -T-verbinder für aussere Kammer -Connecting bracket for outside chamber	UG027	1

Toepassing
Application
Anwendung
Application

Verp. per
Emb. par
Pack pr.
Pack pr.

	ACVG29	1
	<ul style="list-style-type: none"> -Anti-uithefstukje -Anti-dégondage -Anti-aufhebenstück -Anti lift-up piece 	
	ACVG31	VL172 200M
	<ul style="list-style-type: none"> -Beglazingsrubber buiten 3mm -Joint de vitrage extérieur 3mm -Glasanlage dichtung aussen 3mm -Glazing gasket outside 3mm 	
	ACVG42	UG014 100M UG015 UG020 UG051 UG614 VL70
	<ul style="list-style-type: none"> -Borstelafdichting -Brosse -Bürstendichtung -Brush fitting 	
	ACVG045	1
	<ul style="list-style-type: none"> -Afdekkapje waterafvoer (zwart / wit) -Capuchon écoulement d'eau (noir / blanc) -Abdeckkappe entwässerung (schwarz / weiss) -Drain hole cover (black / white) 	
	ACVG045-2500	2500
	ACVG57	UG010 1 UG011 UG610
	<ul style="list-style-type: none"> -Stormventieltje -Clapet anti-réroulement -Sturm ventil -Storm valve 	

Toepassing
Application
Anwendung
Application

Verp. per
Emb. par
Pack pr.
Pack pr.

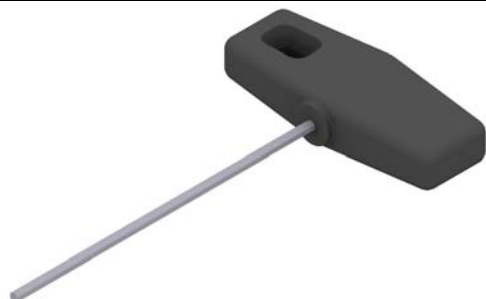
**ACVG65**

-Zeskantsleutel 2.5mm
-Clé à six pans 2.5mm
-Sechskantschlüssel 2.5mm
-T-handle hexagon key 2.5mm

ACUG013

1

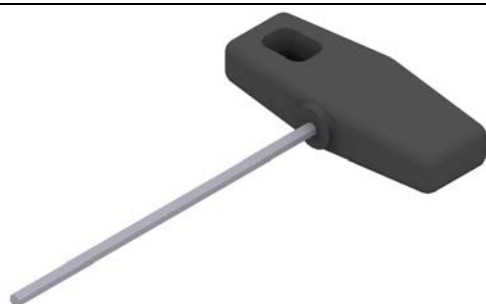
**ACVG66**

-Zeskantsleutel 3mm
-Clé à six pans 3mm
-Sechskantschlüssel 3mm
-T-handle hexagon key 3mm

ACUG013
ACUG015
ACUG017
ACUG019
ACUG021
ACUG023
ACUG024

1

Toepassing	Verp. per
Application	Emb. par
Anwendung	Pack pr.
Application	Pack pr.

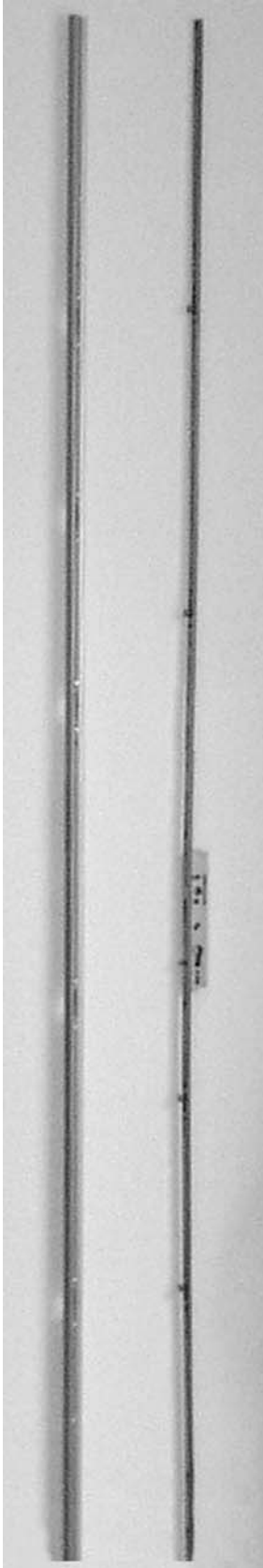
**ACVG55I**

1

- Inbraakvertragend 5 puntslot + slotplaat
- Serrure 5 point + gache pour anti effraction
- 5 Punkt Schloss + Platte für einbruchhemmend
- Lock with 5 points + lock plate for burglary proof

H=2370mm

Toepassing
Application
Anwendung
Application

Verp. per
Emb. par
Pack pr.
Pack pr.



ACVG554

- Binnenkruk inbraakvertragend
- Poignée intérieure anti effraction
- Krücke innen einbruchhemmend
- Handle inside burglary proof

UG020
ACVG551

1



ACVG750

- Slotplaat
- Gâche
- Schliessplatte
- Lock plate

ACVG751

1

Toepassing	Verp. per
Application	Emb. par
Anwendung	Pack pr.
Application	Pack pr.





ACVG75I

1

- Meerpuntsluiting 5p.
- Fermeture multi-points 5p.
- Multipunkte Verschluss 5p.
- Multiple point lock 5p.

H=2170mm

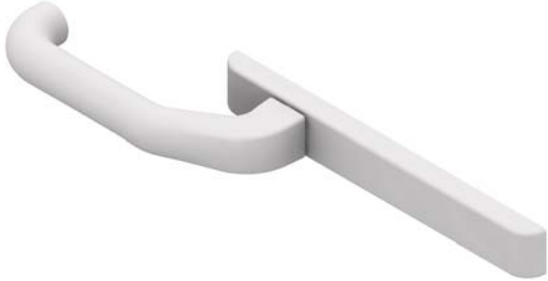

		Toepassing Application Anwendung Application	Verp. per Emb. par Pack pr. Pack pr.
	ACVG754 -Binnenkruk -Poignée intérieure -Handgriff innen -Inside handle	ACUG749 ACVG751	1
	ACVG758 -Binnenkruk zonder cilindergat -Poignée intérieure sans trou de cylindre -Handgriff innen ohne Zylinder loch -Inside handle without cylinder gap	ACUG749 ACVG751	1
	ACVG762 -Vaste binnenkruk -Poignée intérieure fixe -Krücke intern unbeweglich -Inside handle fixed	ACUG749 ACVG751	1
	ACVG763 -Vaste buitenkruk -Poignée extérieure fixe -Krücke aussen unbeweglich -Outside handle fixed	ACUG749 ACVG751	1
	ACVG764 -Kongreep buiten -Cuvette extérieur -Griff aussen -Grip outside	ACVG754 ACVG758	1

Toepassing
Application
Anwendung
Application

Verp. per
Emb. par
Pack pr.
Pack pr.

	<p>ACVL020</p> <ul style="list-style-type: none"> -Verstekhoekje in inox -Equerre de jonction en inox -Eckverstärkung in inox -Framing square in stainless steel 	1
	<p>ACVL020B</p> <ul style="list-style-type: none"> -Verstekhoekje in kunststof -Equerre de jonction en plastique -Eckverstärkung in plastik -Framing square in plastic 	1 2500
	<p>ACVL029</p> <ul style="list-style-type: none"> -Verstevigingsstukje voor T-verbinder -Pièce renforcement pour assemblage-T -Verstärkung stück für T-verbinder -Strengthening piece for connecting bracket 	1
	<p>ACVL033</p> <ul style="list-style-type: none"> -Borsteldichting -Brosse -Burstendichtung -Brush fitting 	VL70 50M
	<p>ACVL058</p> <ul style="list-style-type: none"> -Klemstuk -Clip -Befestigungsklotz -Clip 	VL70 1

Toepassing
Application
Anwendung
Application

Verp. per
Emb. par
Pack pr.
Pack pr.

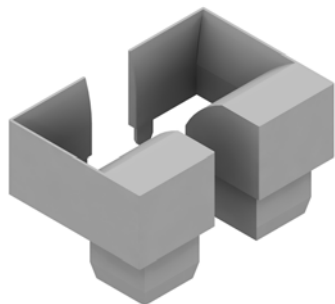
**ACVL062**

VL70

1 SET

- Inloopstuk rolluikgeleider (zwart / wit)
- Entonnoir coulisseau store (noir / blanc)
- Inlaufstück für Rolladen (schwarz / weiss)
- Enterpiece for shutter (black / white)

**ACVL063**

VL71

1

- Aandrukrol voor rolluik
- Rouleau renvoi pour store
- Andrückrolle für Rolladen
- Push roller for shutter

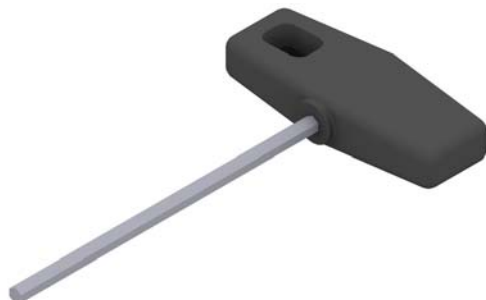
**ACVLI50**ACUG024
ACUG025

1

- Zeskantsleutel 4mm
- Clé à six pans 4mm
- Sechskantschlüssel 4mm
- T-handle hexagon key 4mm

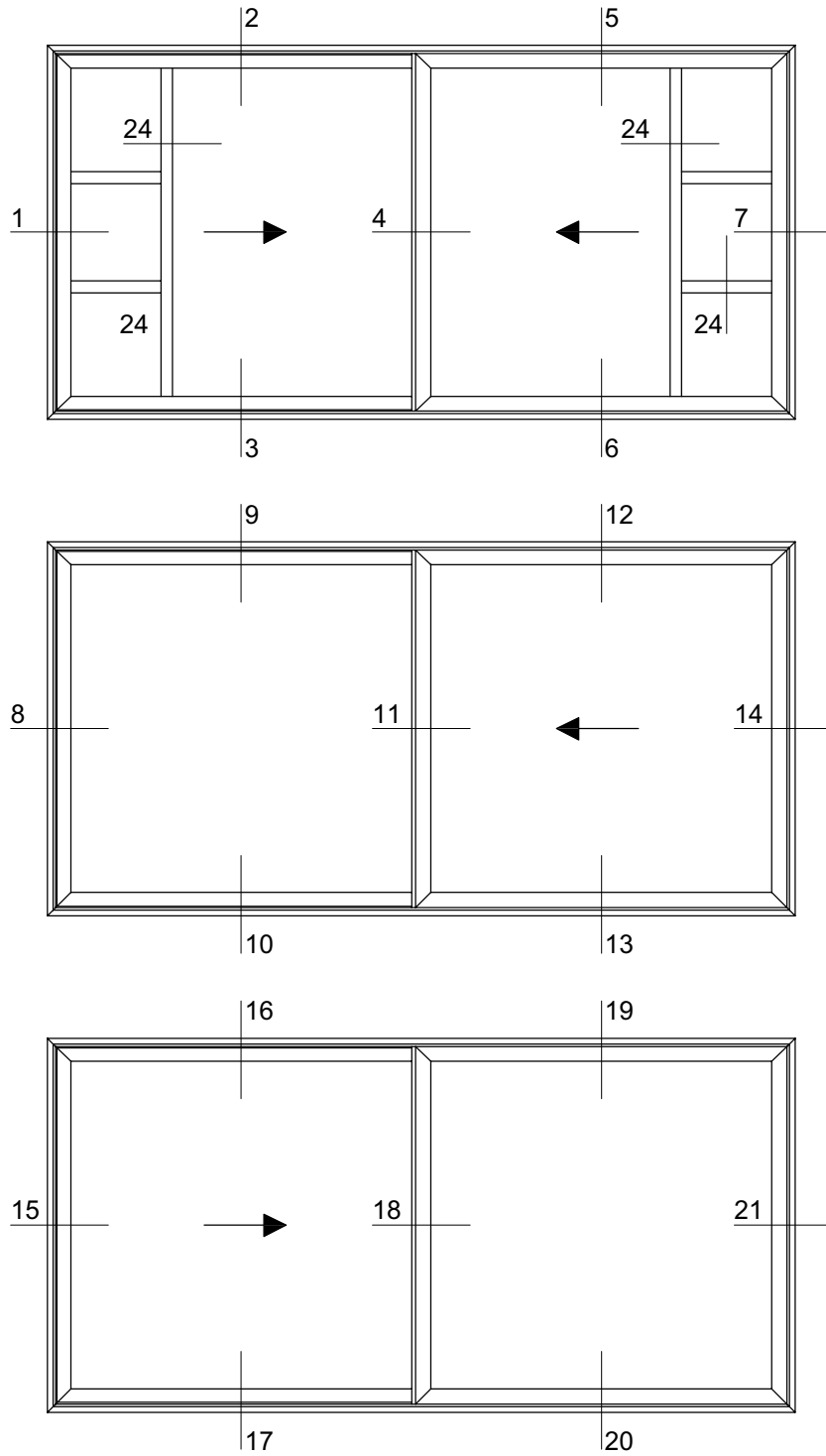

type01

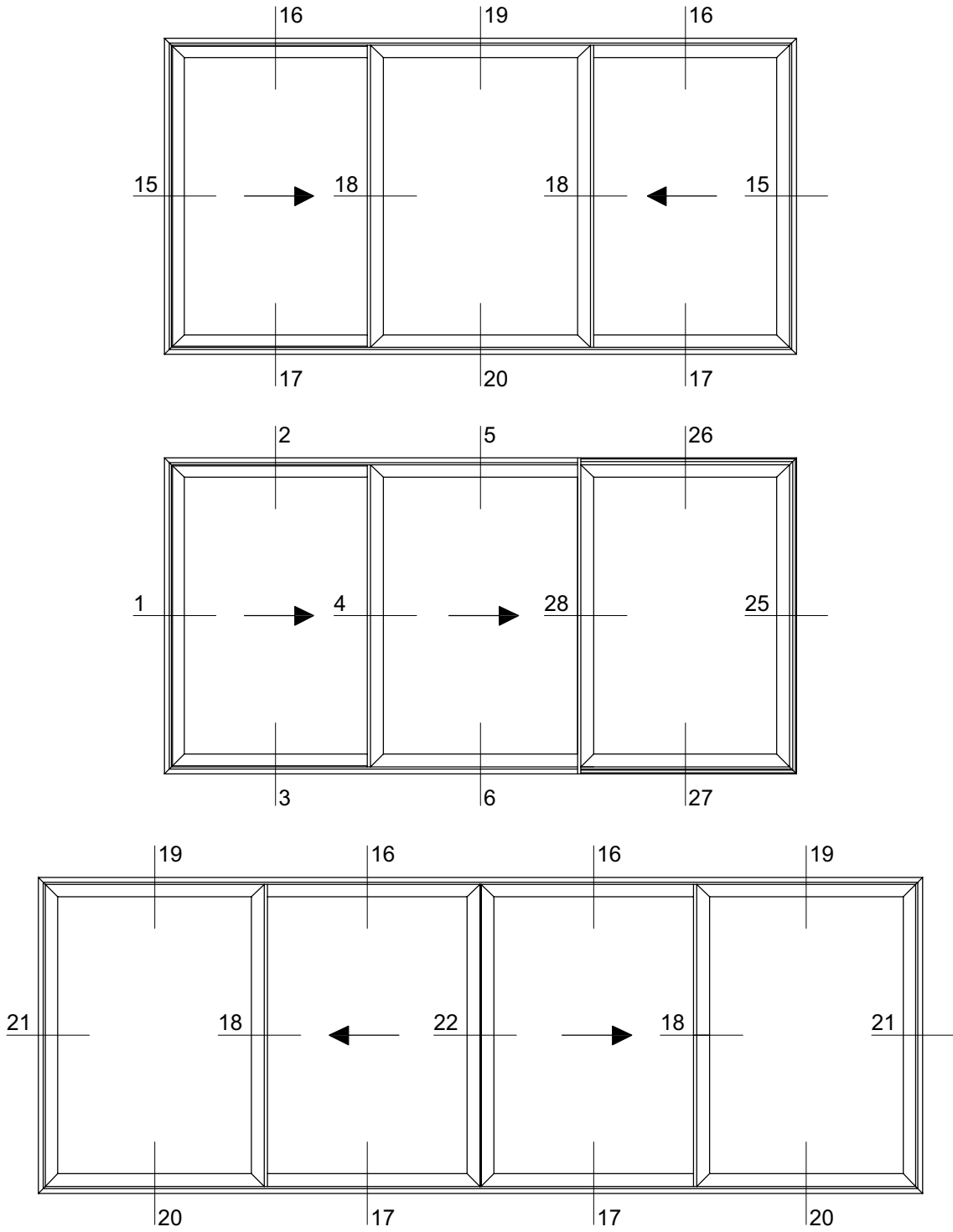

type02

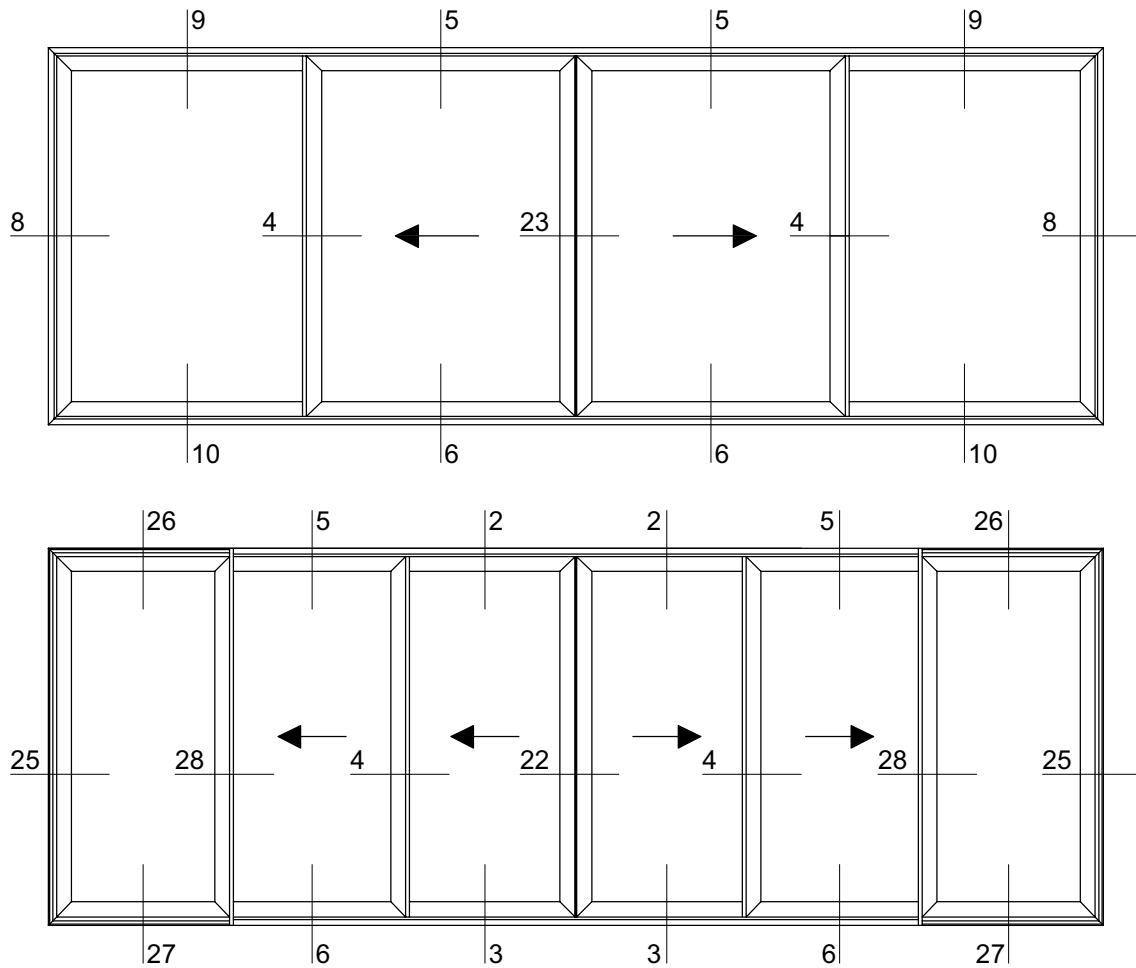

DOORSNEDE - COUPE - SCHNITT - SECTIONS

type03

1A

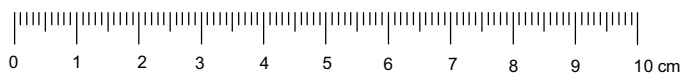
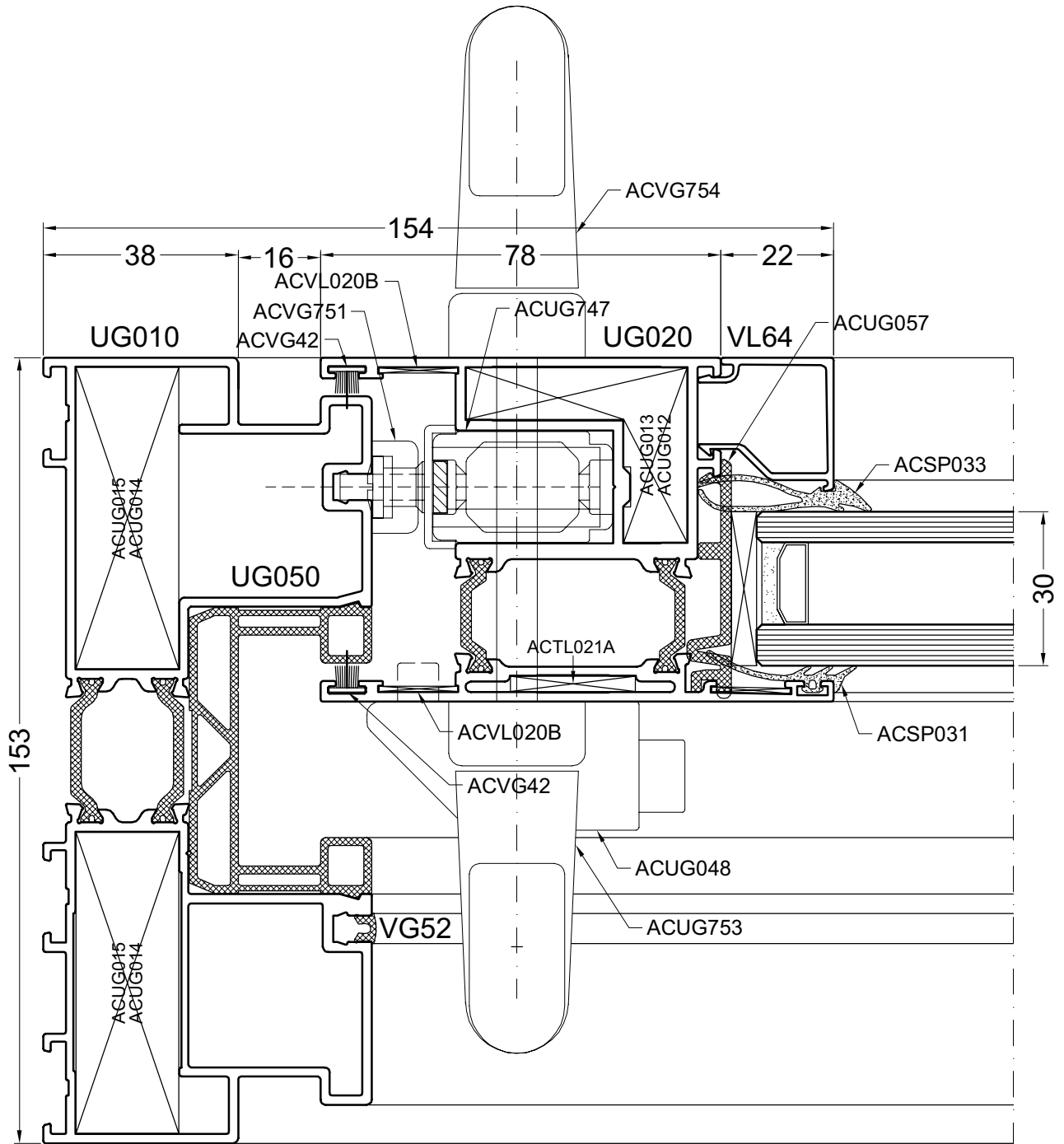

door1

1B

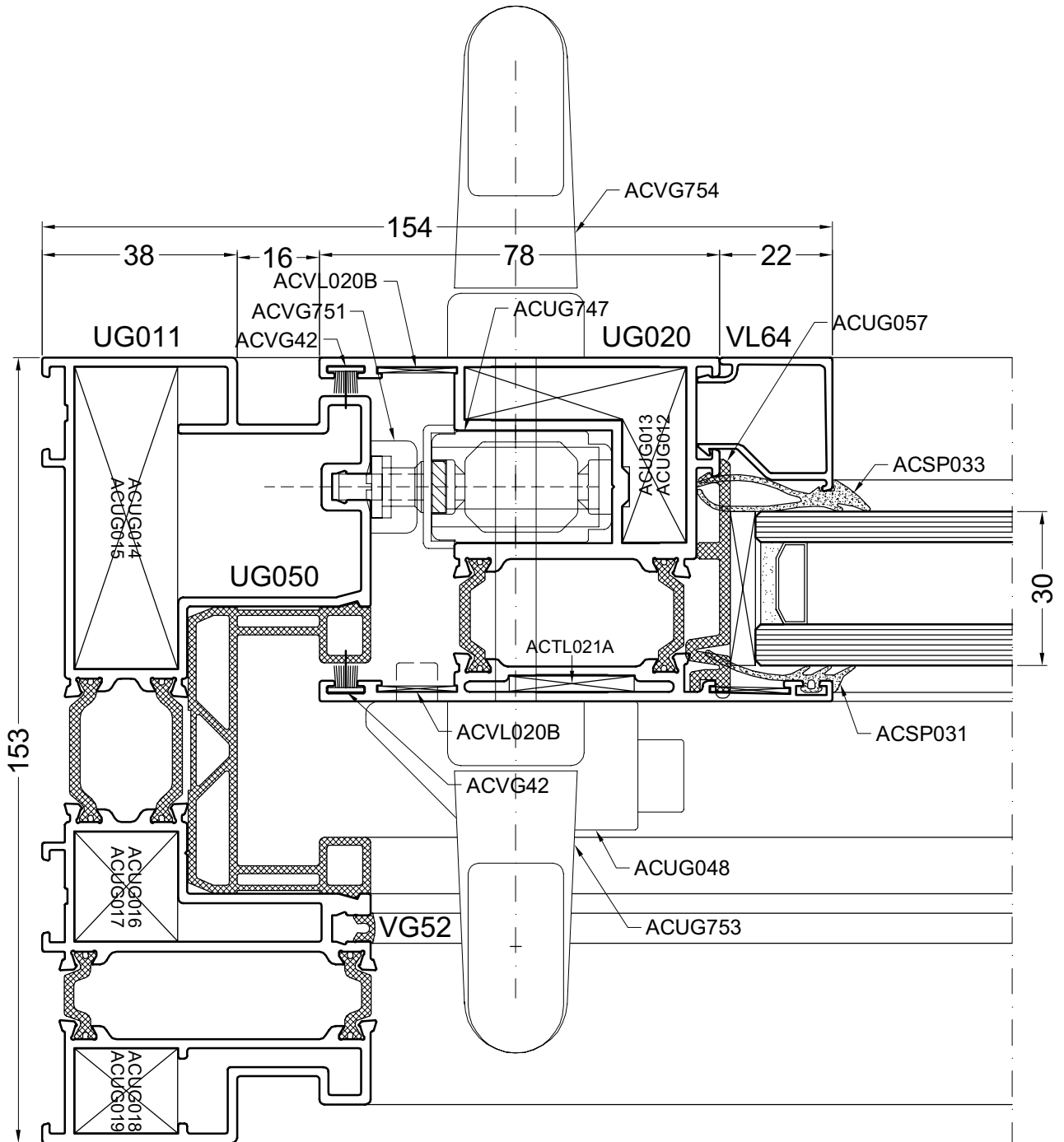

DOORSNEDE - COUPE - SCHNITT - SECTIONS



door1a

2A

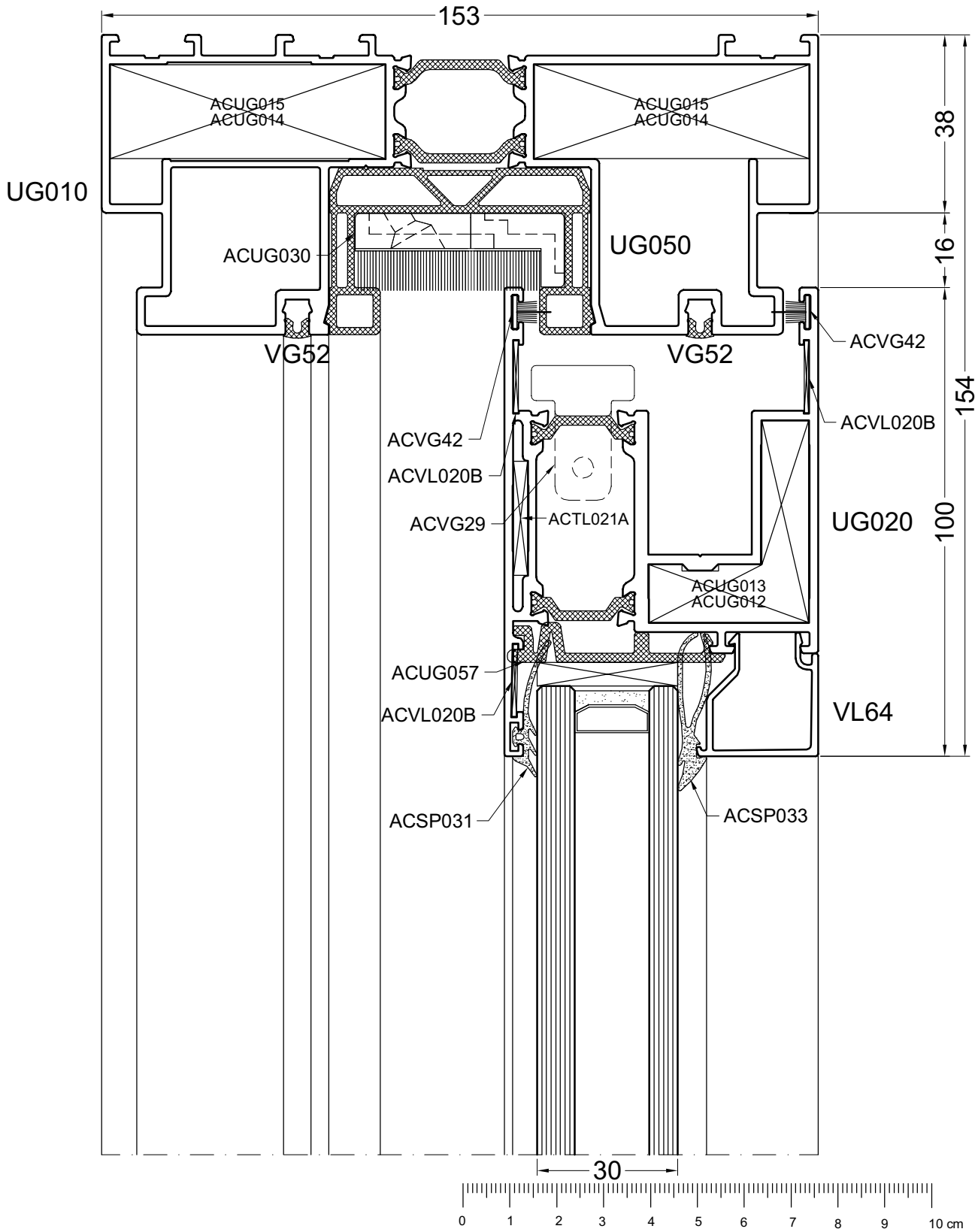

door2

2B

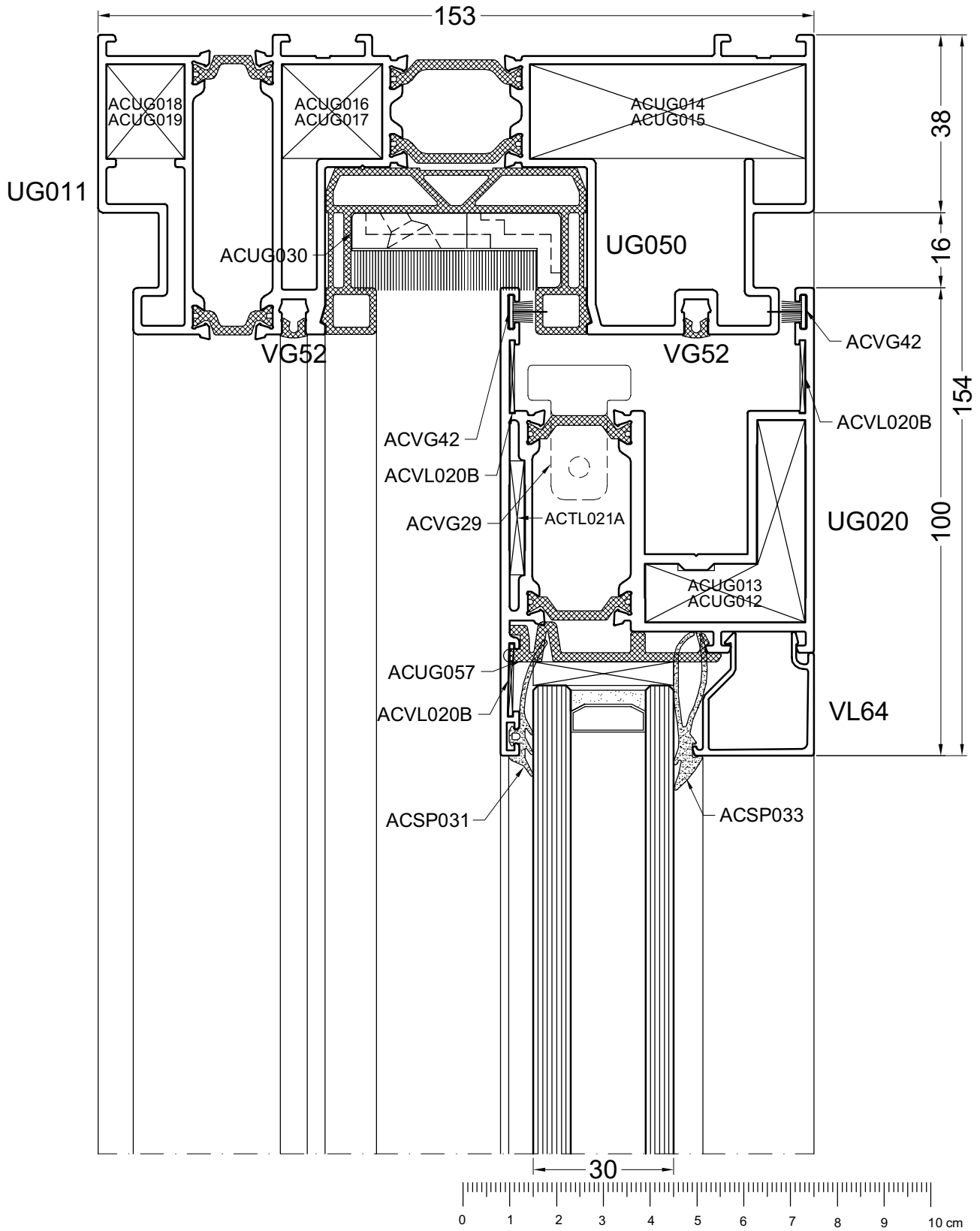

DOORSNEDE - COUPE - SCHNITT - SECTIONS

door2a

3A

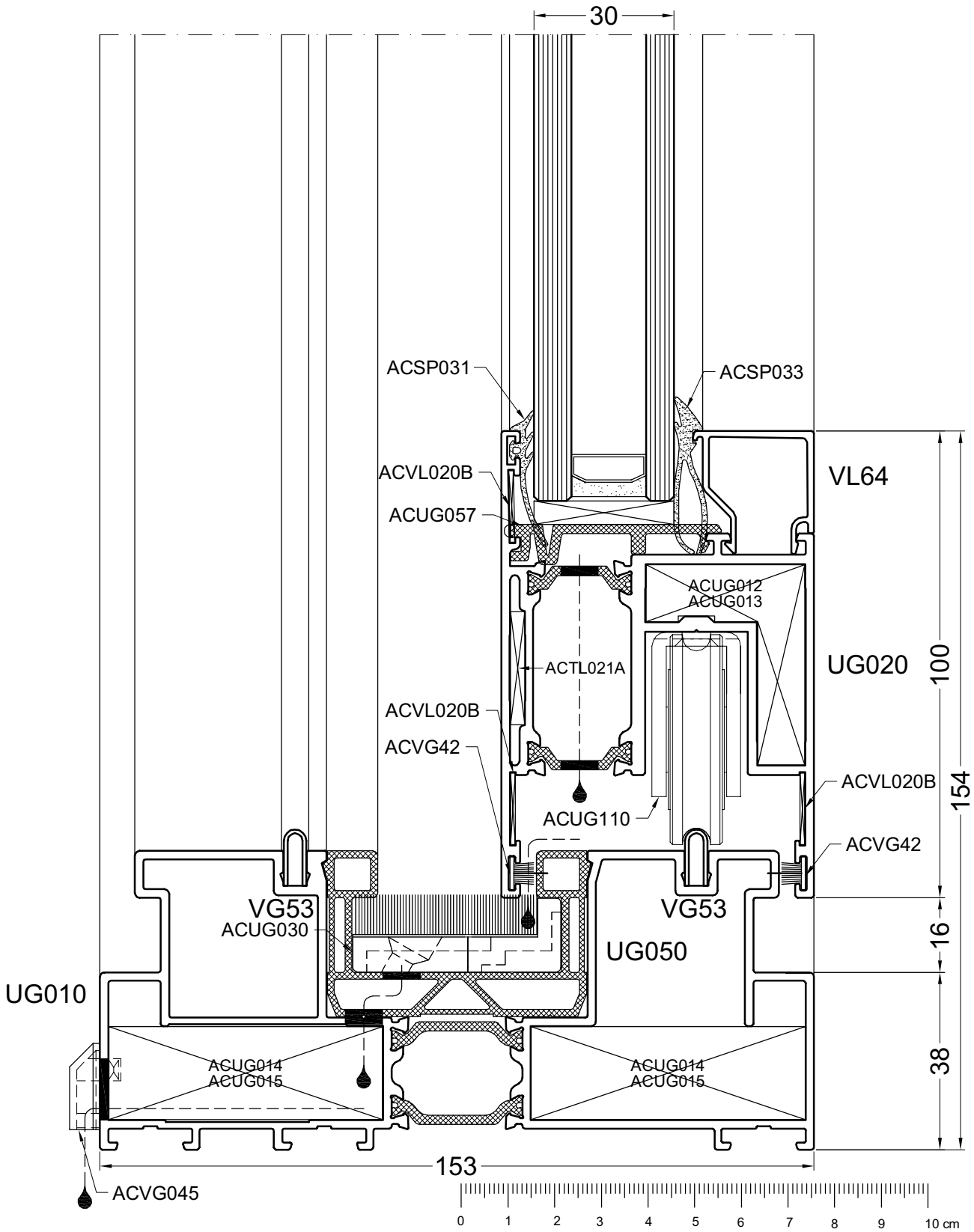

door3

3B

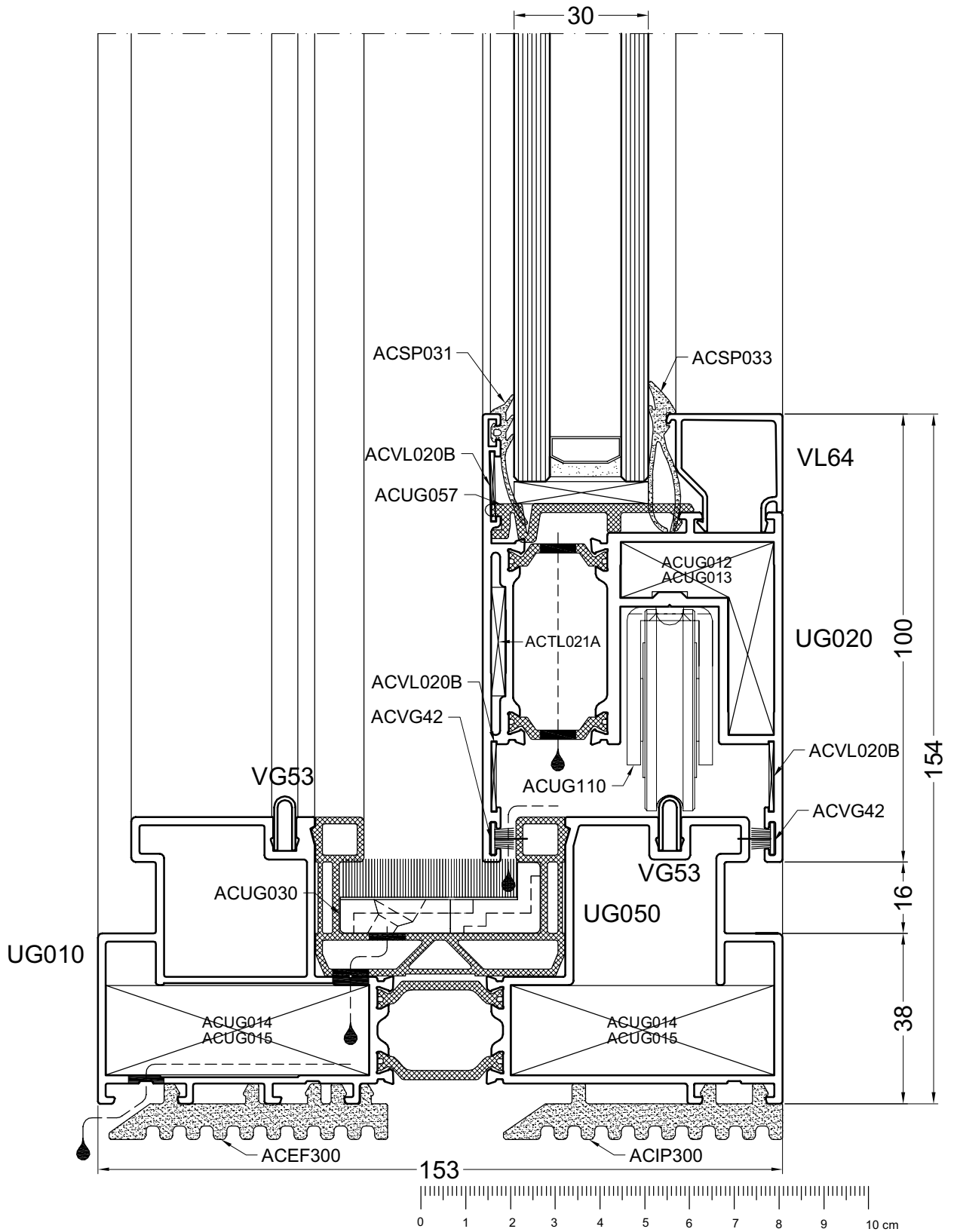

DOORSNEDE - COUPE - SCHNITT - SECTIONS

door3a

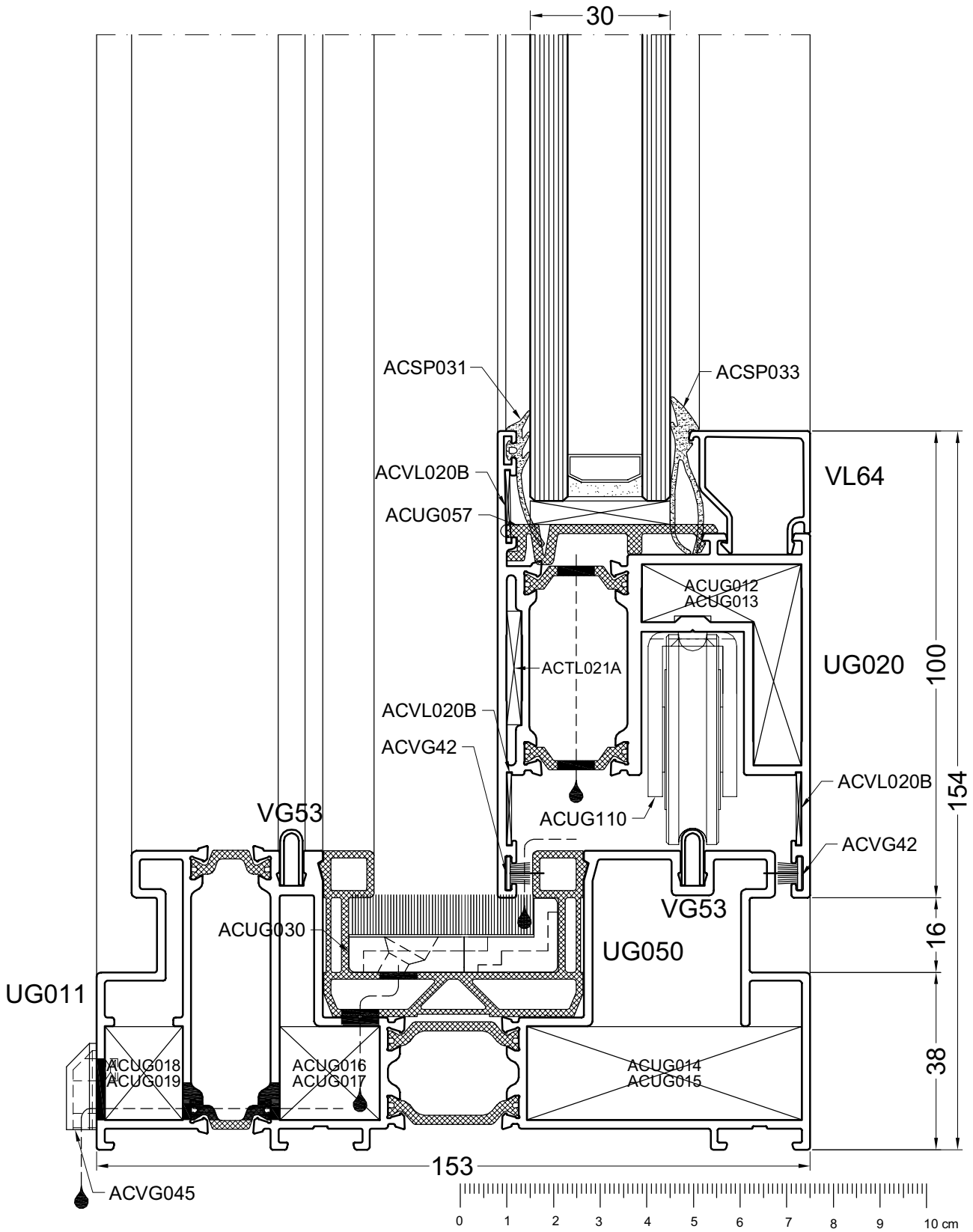

door3b

4A

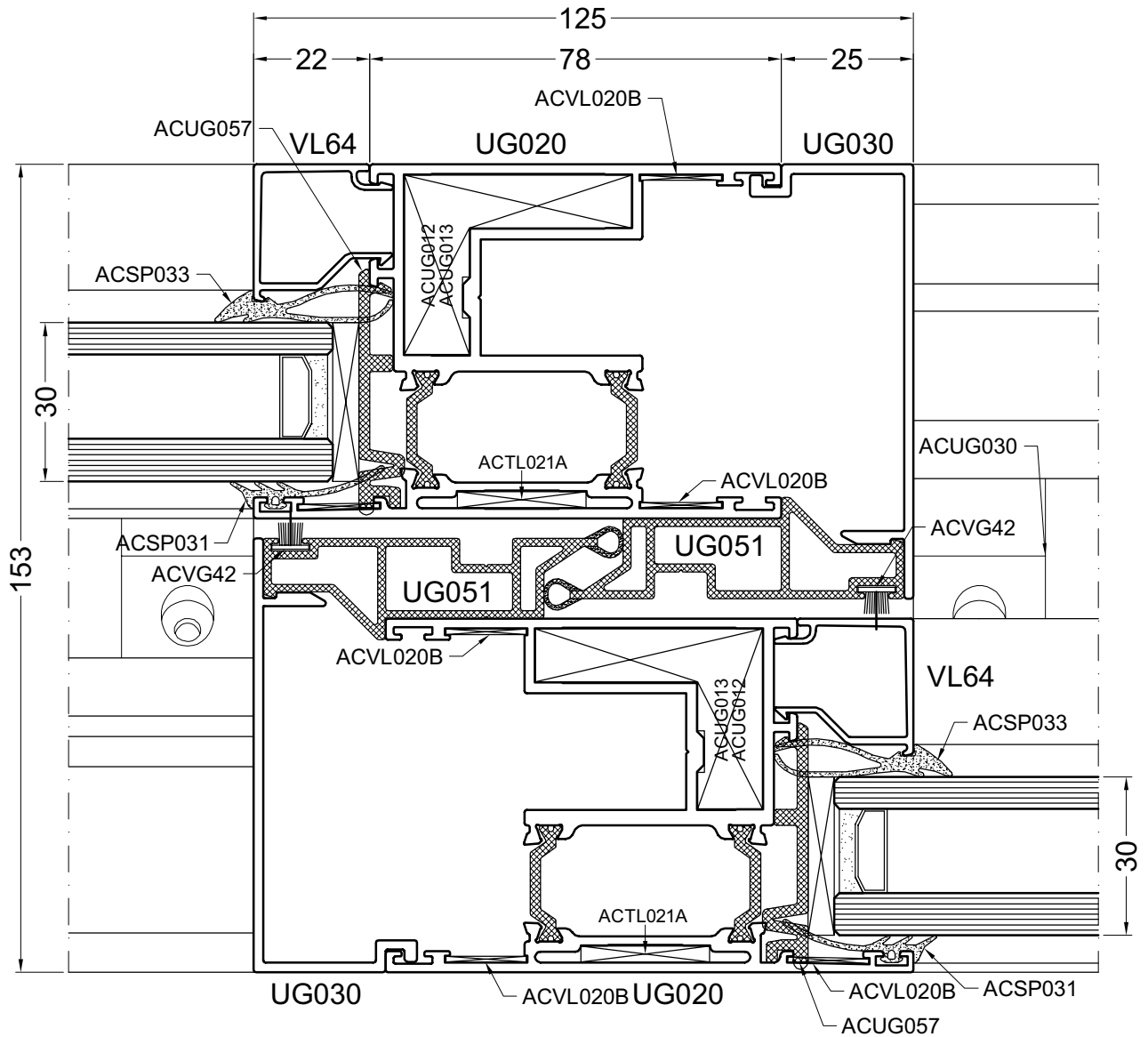

door4

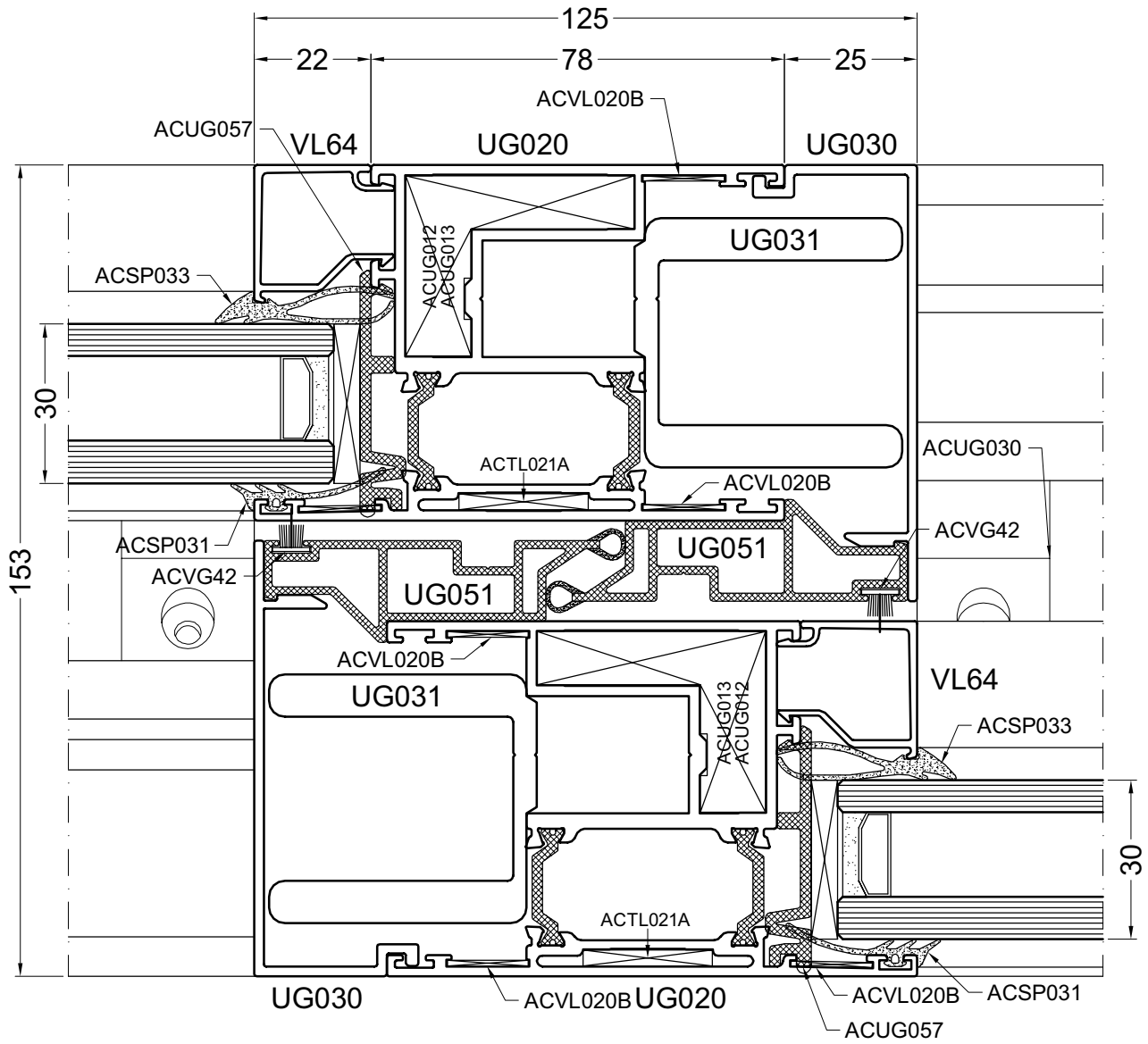

door4a

5A

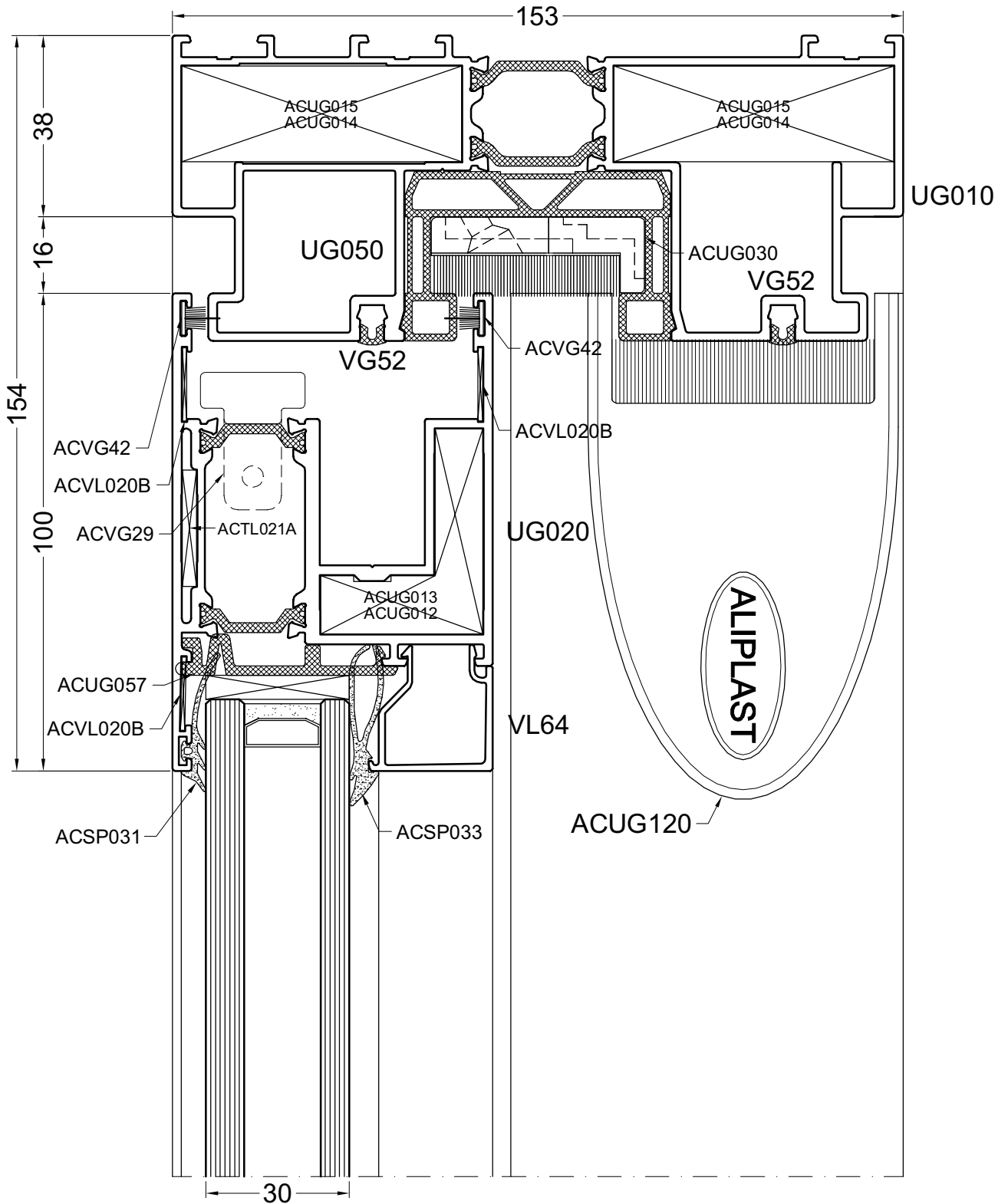

DOORSNEDE - COUPE - SCHNITT - SECTIONS

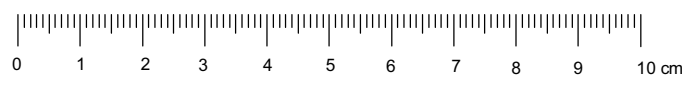

door5

5B

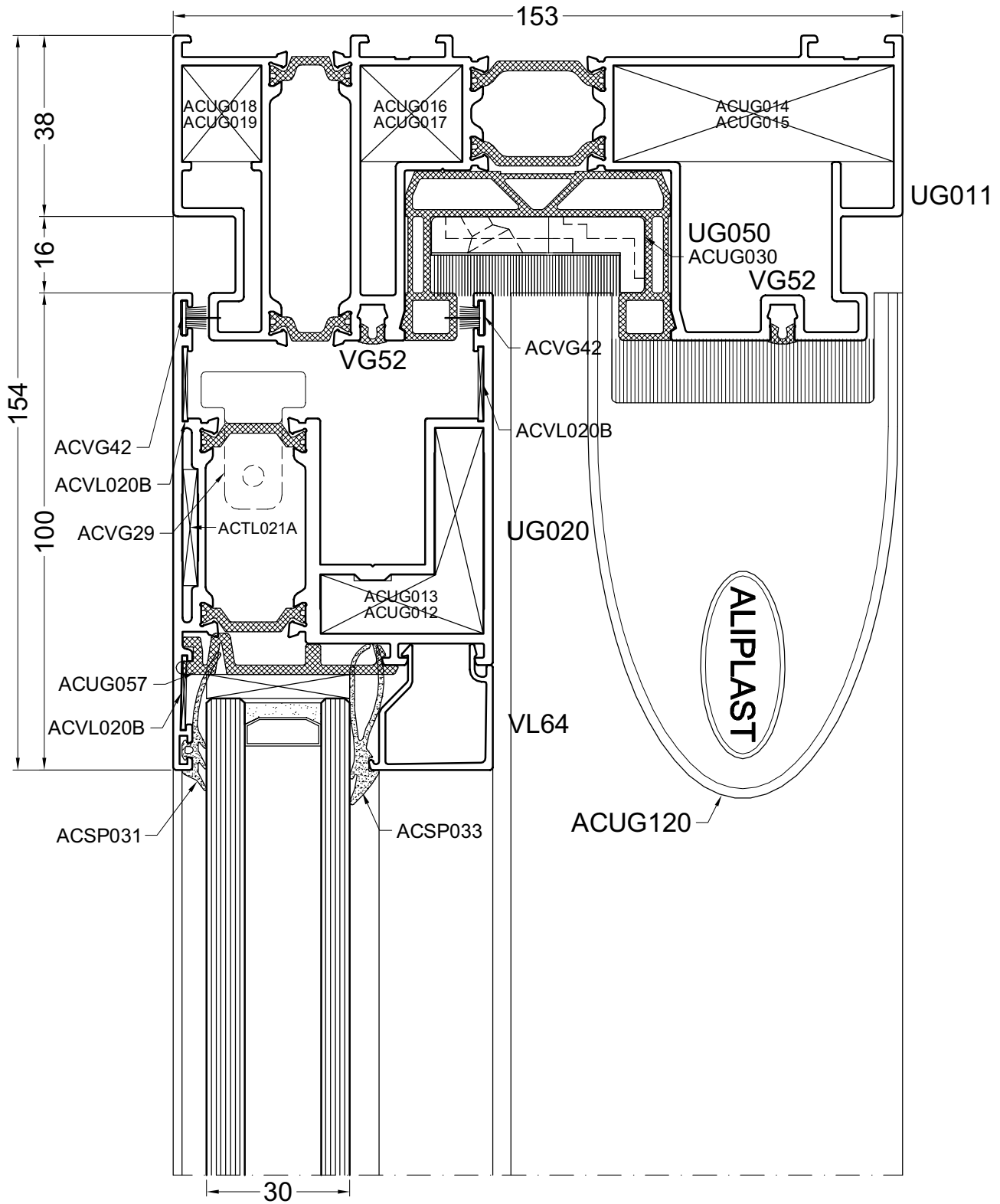

door5a

6A

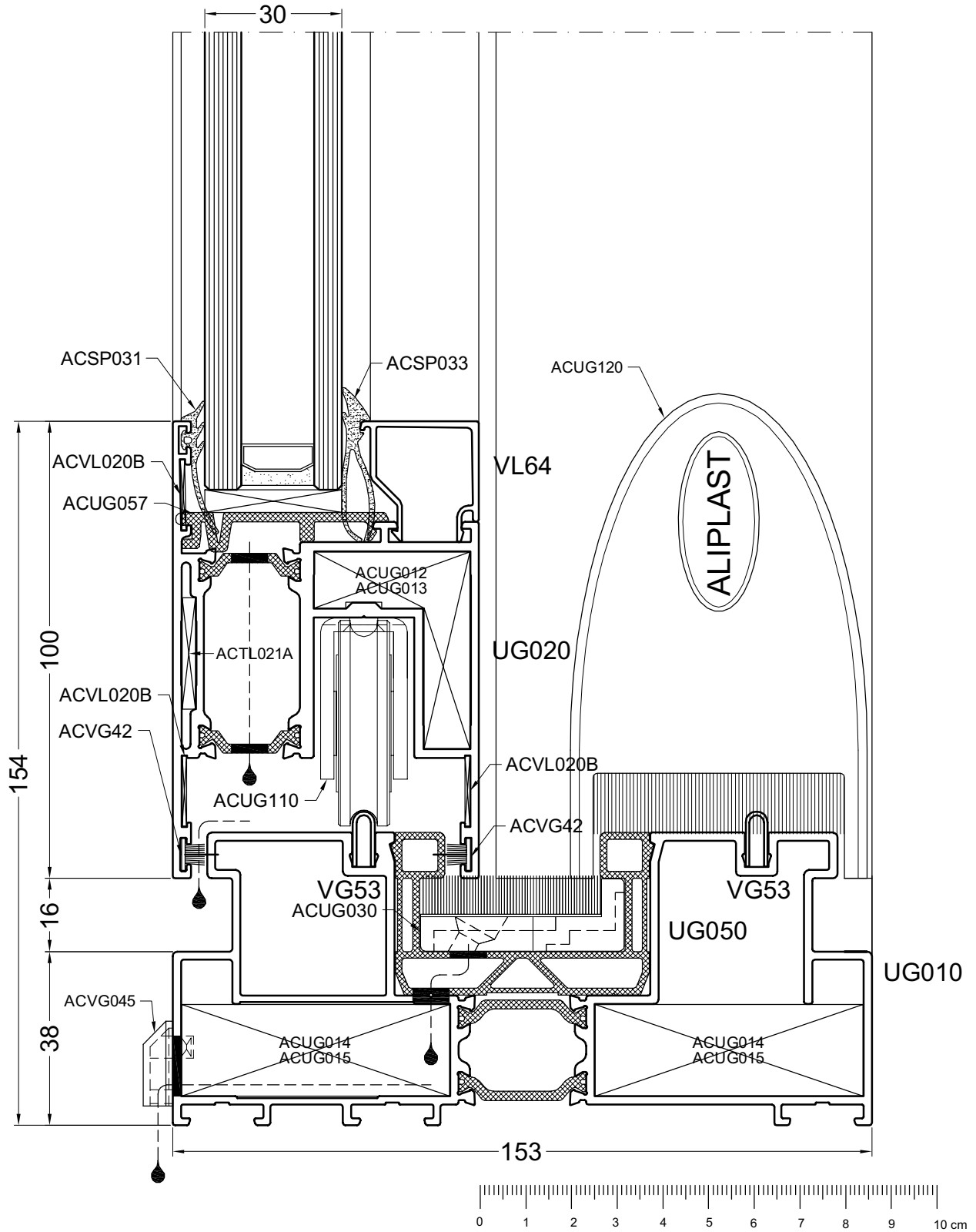

DOORSNEDE - COUPE - SCHNITT - SECTIONS

door6

6B

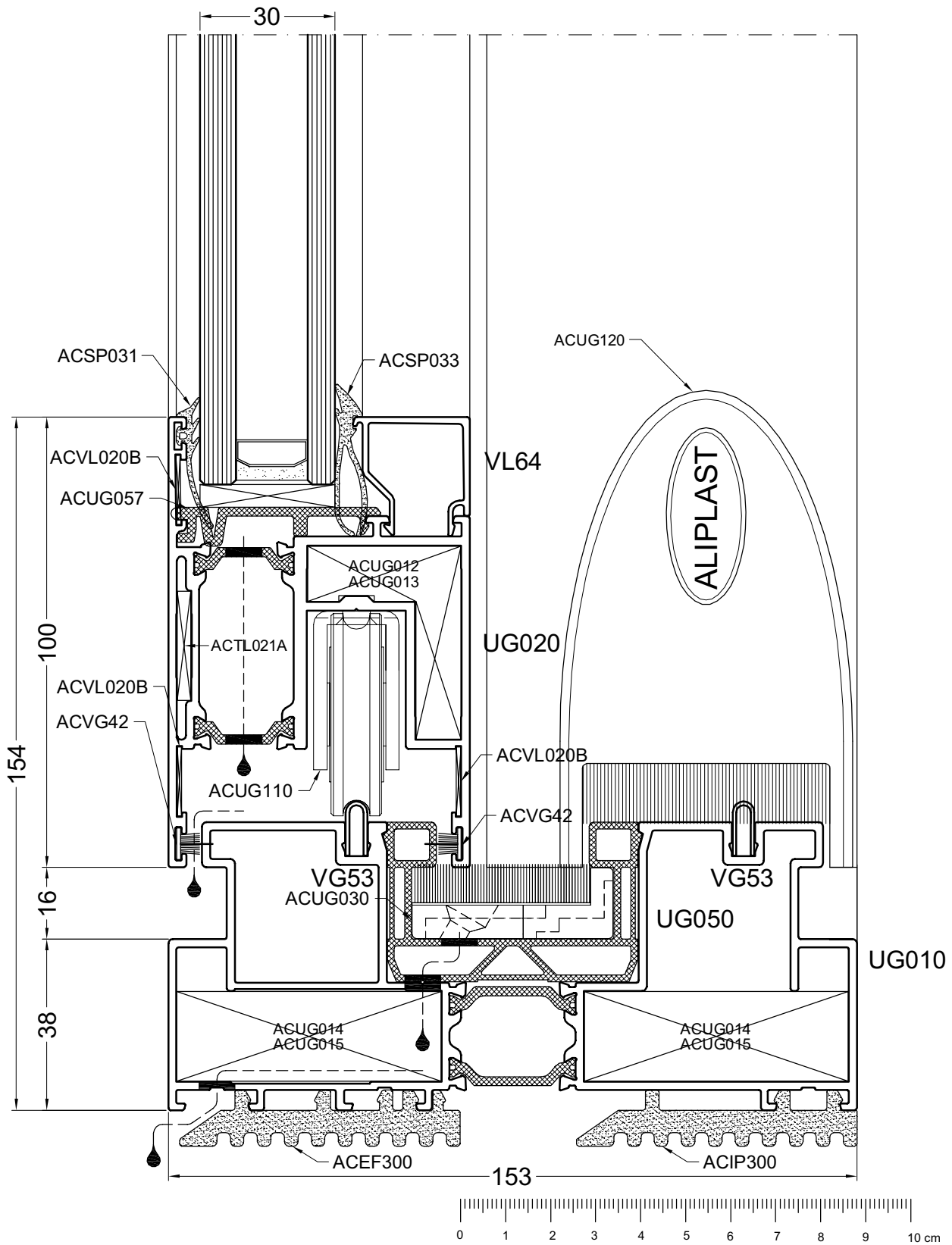

door6a

6C

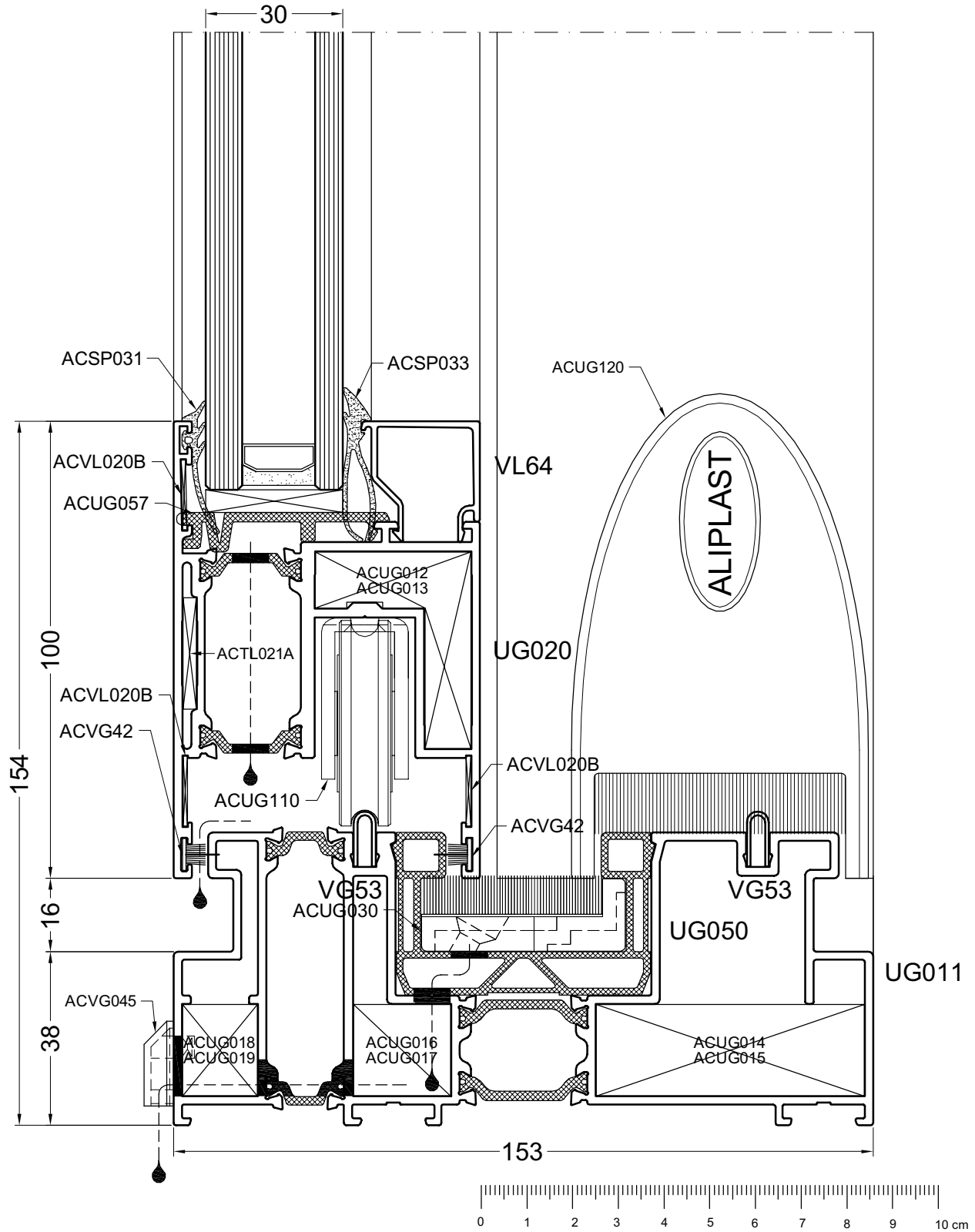

DOORSNEDE - COUPE - SCHNITT - SECTIONS

door6b

7A

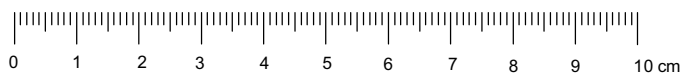
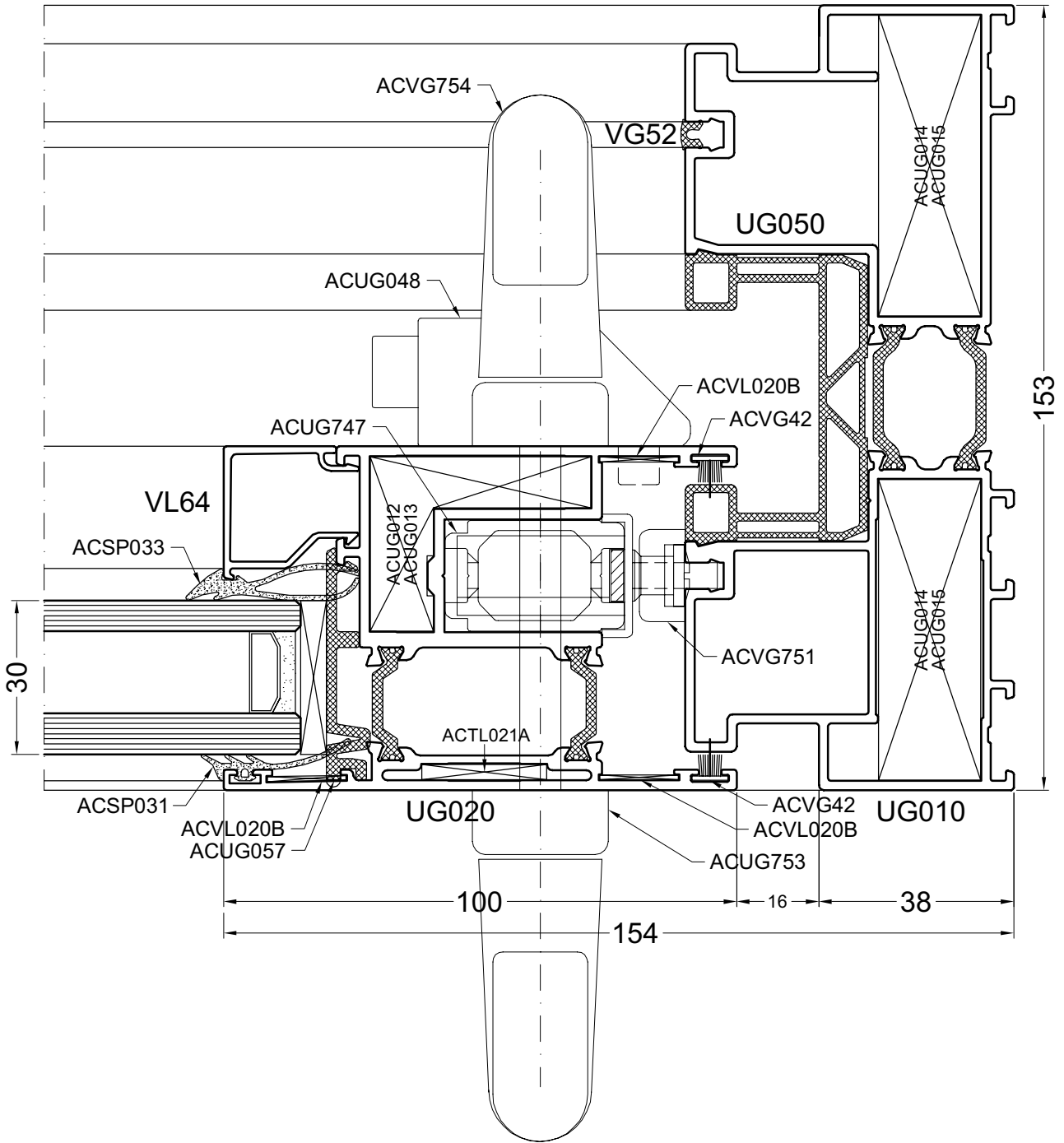

door7

7B

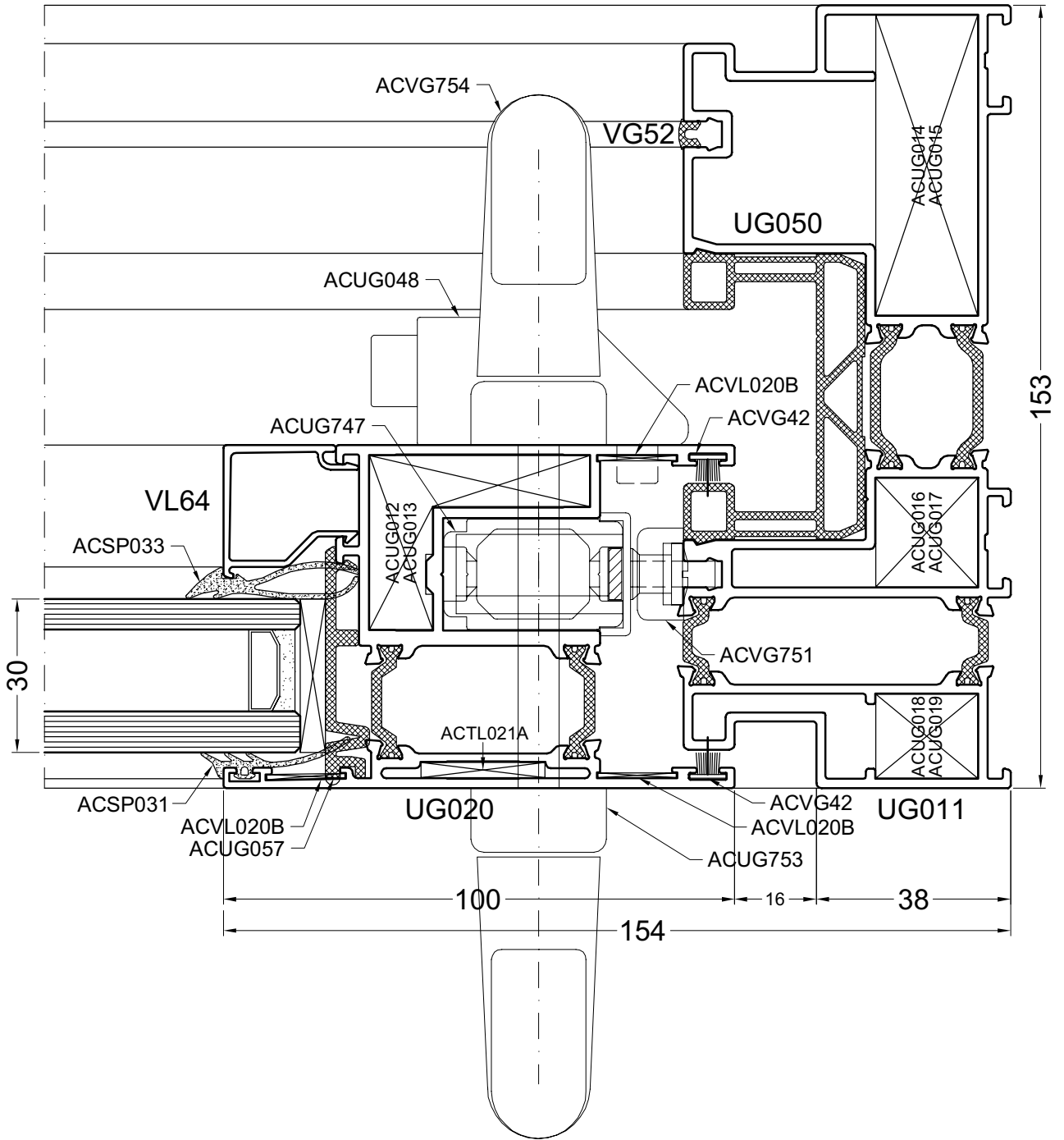

DOORSNEDE - COUPE - SCHNITT - SECTIONS

door7a

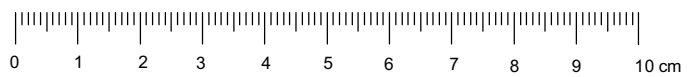

8A

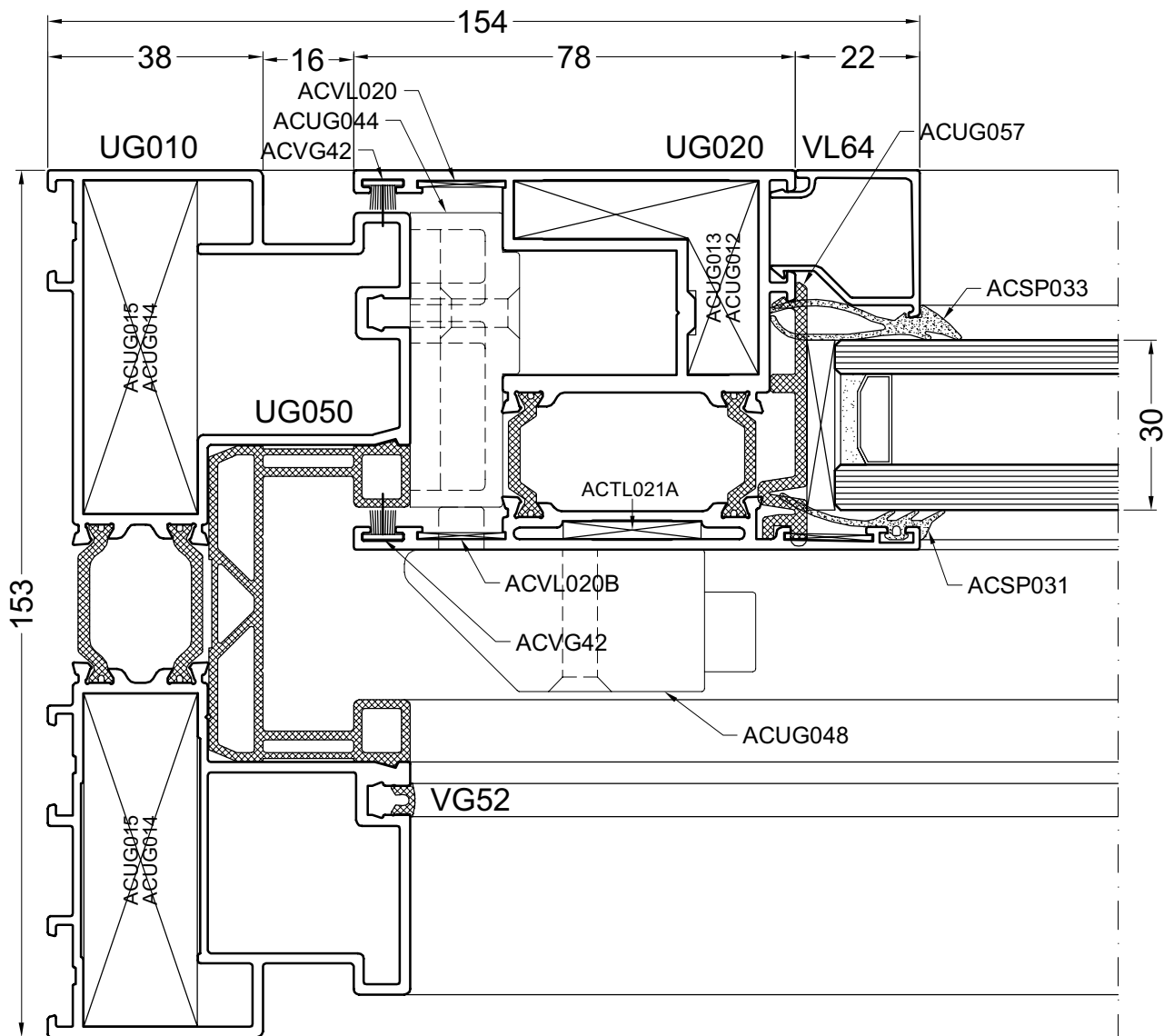

door8

8B

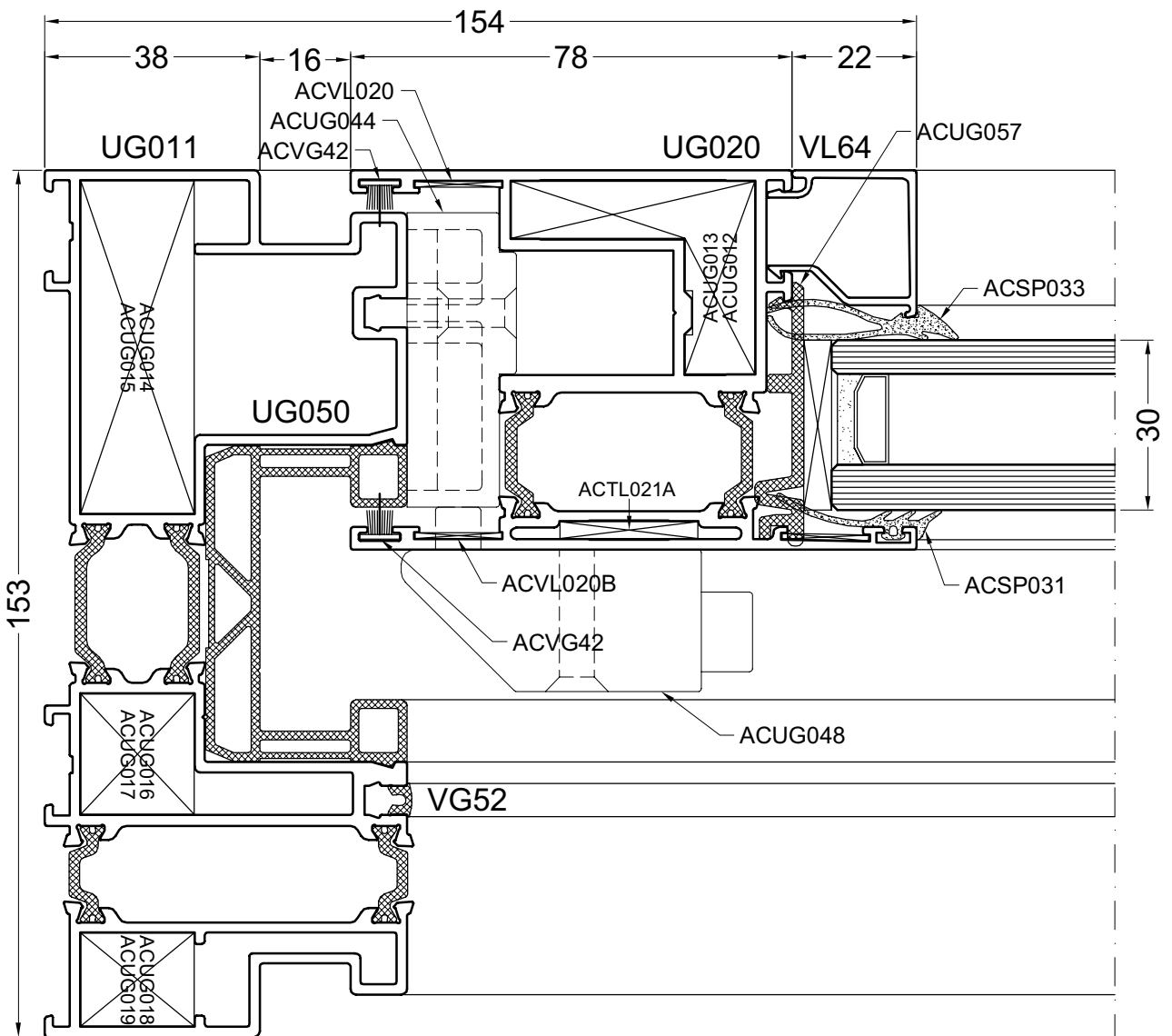

DOORSNEDE - COUPE - SCHNITT - SECTIONS



door8a

9A

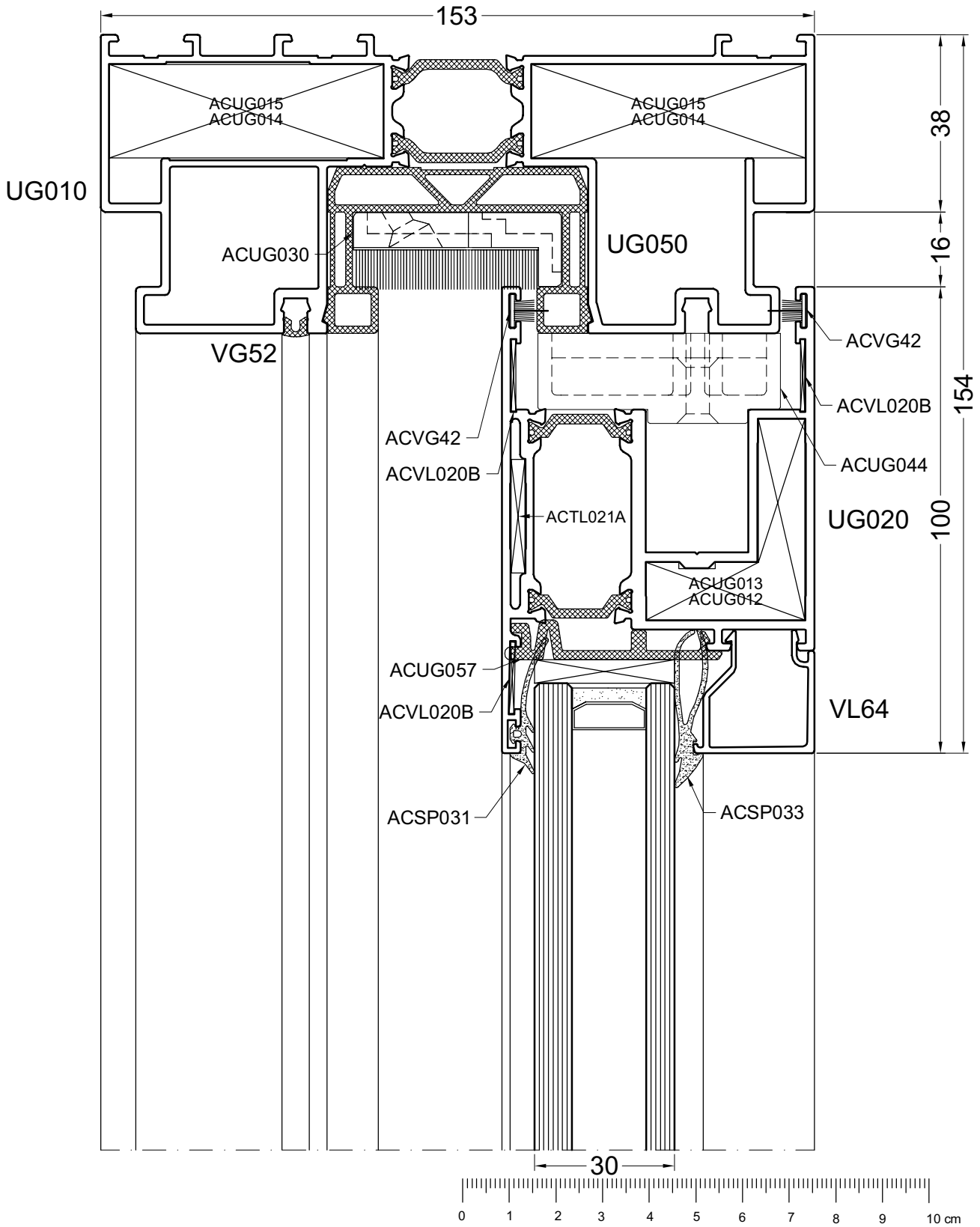

door9

9B

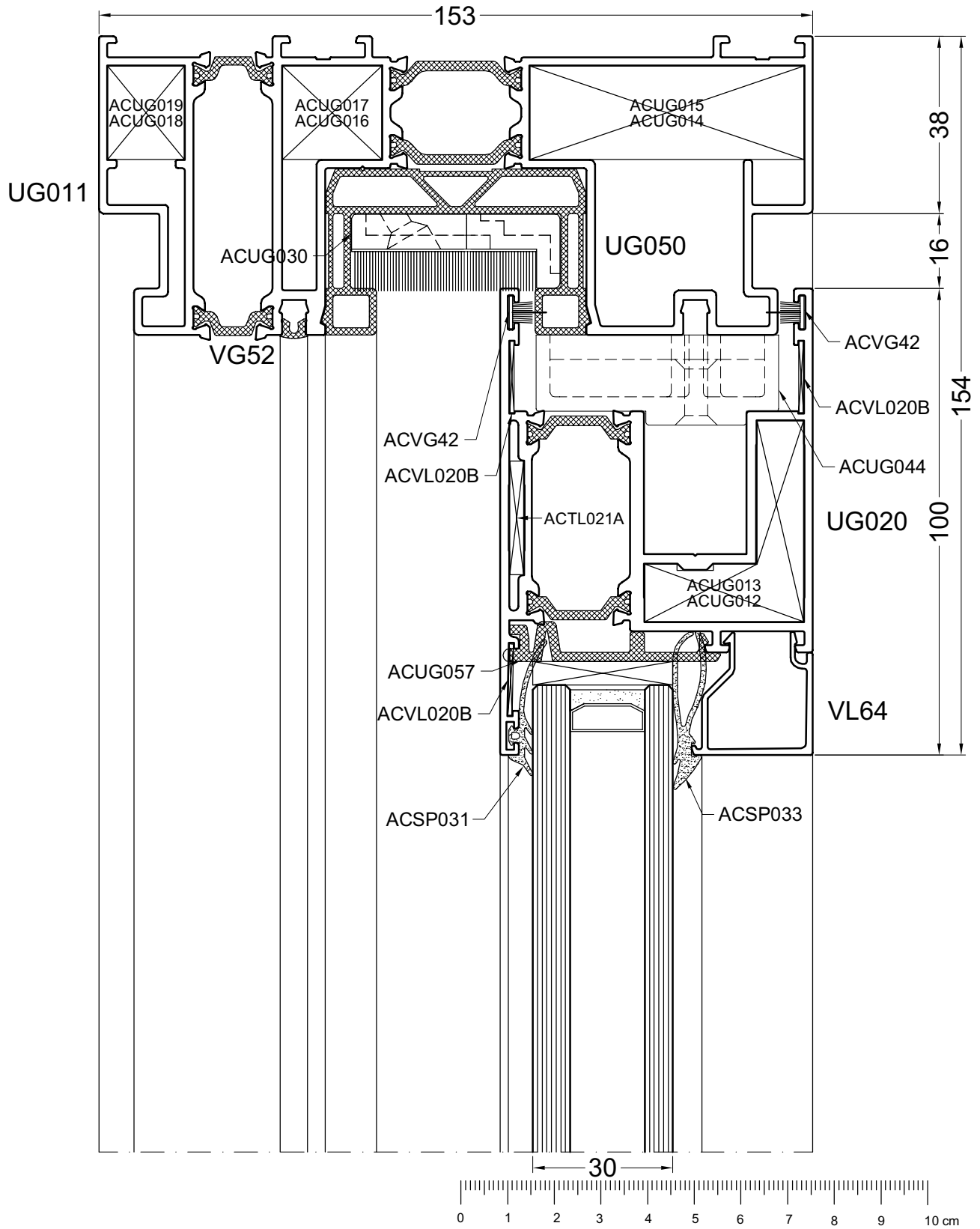

DOORSNEDE - COUPE - SCHNITT - SECTIONS

door9a

10A

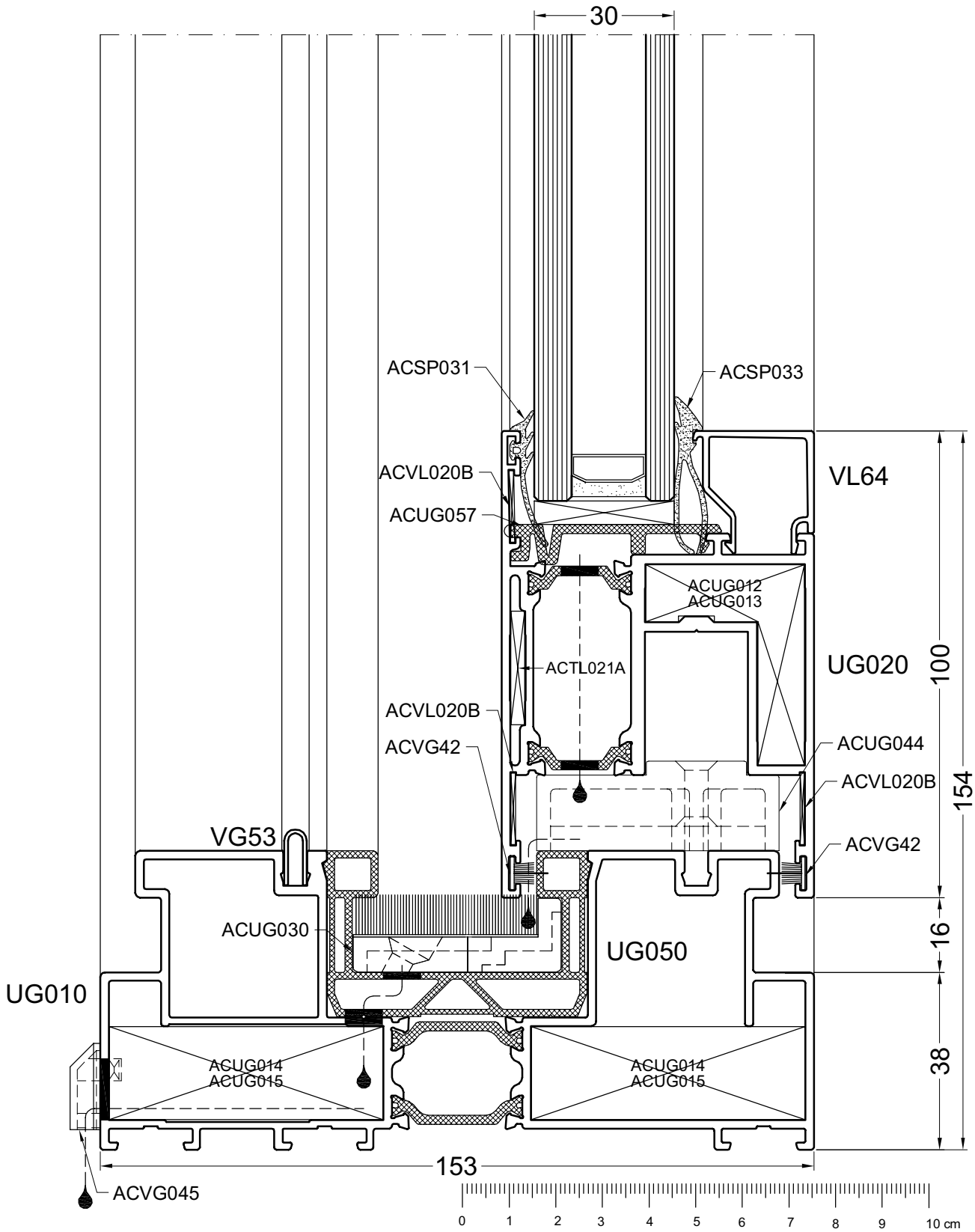

door10

10B

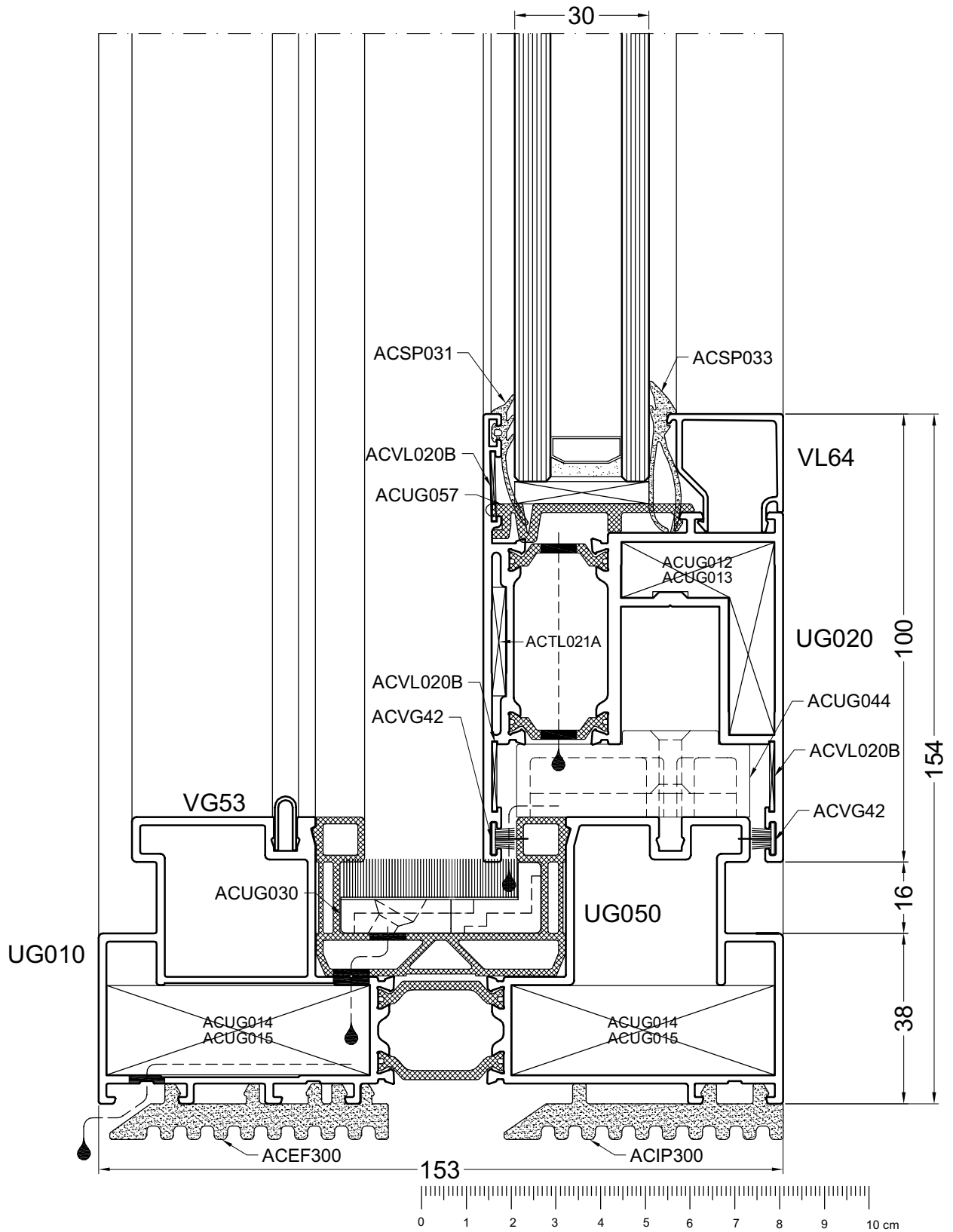

DOORSNEDE - COUPE - SCHNITT - SECTIONS

door10a

10C

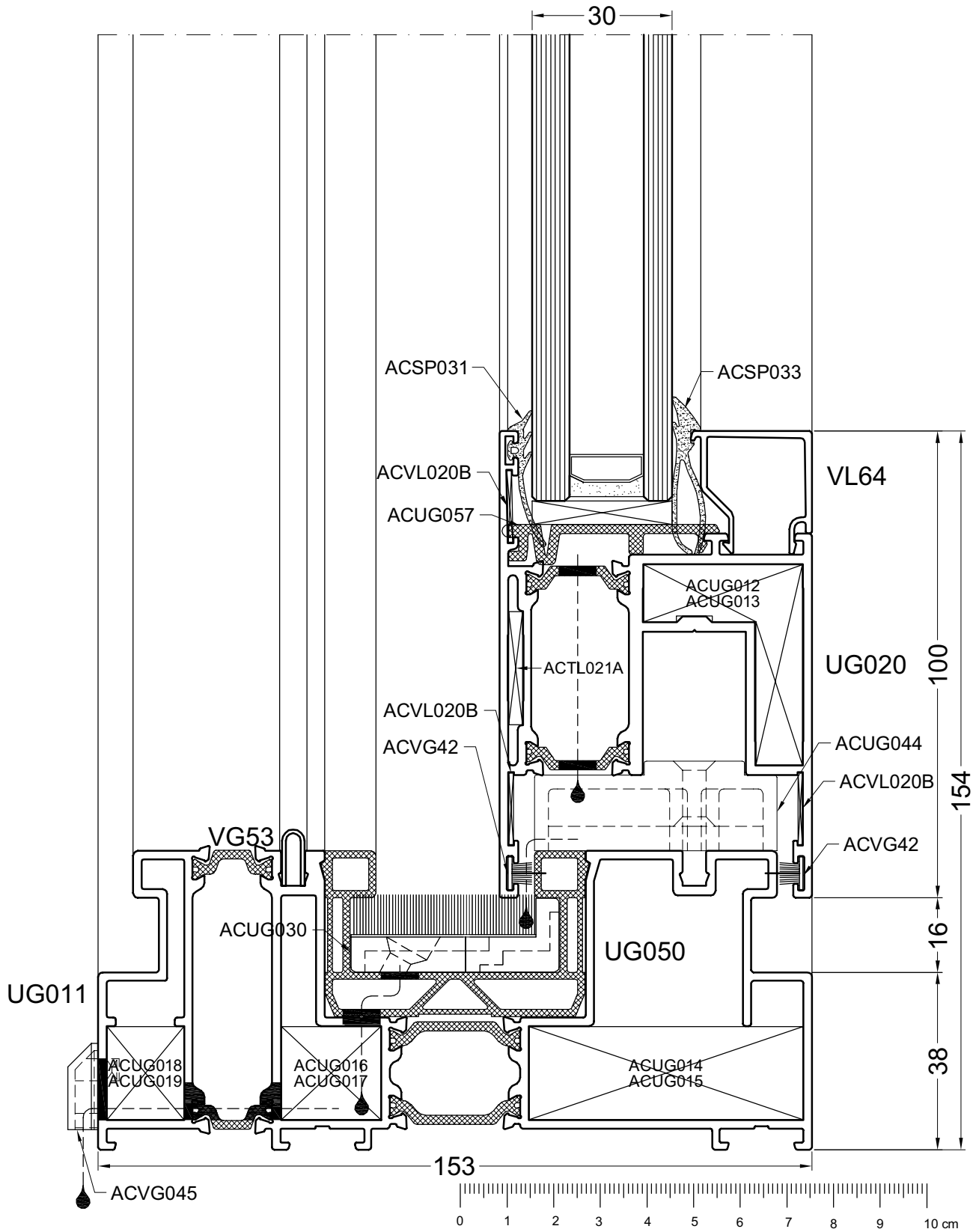

door10b

11A

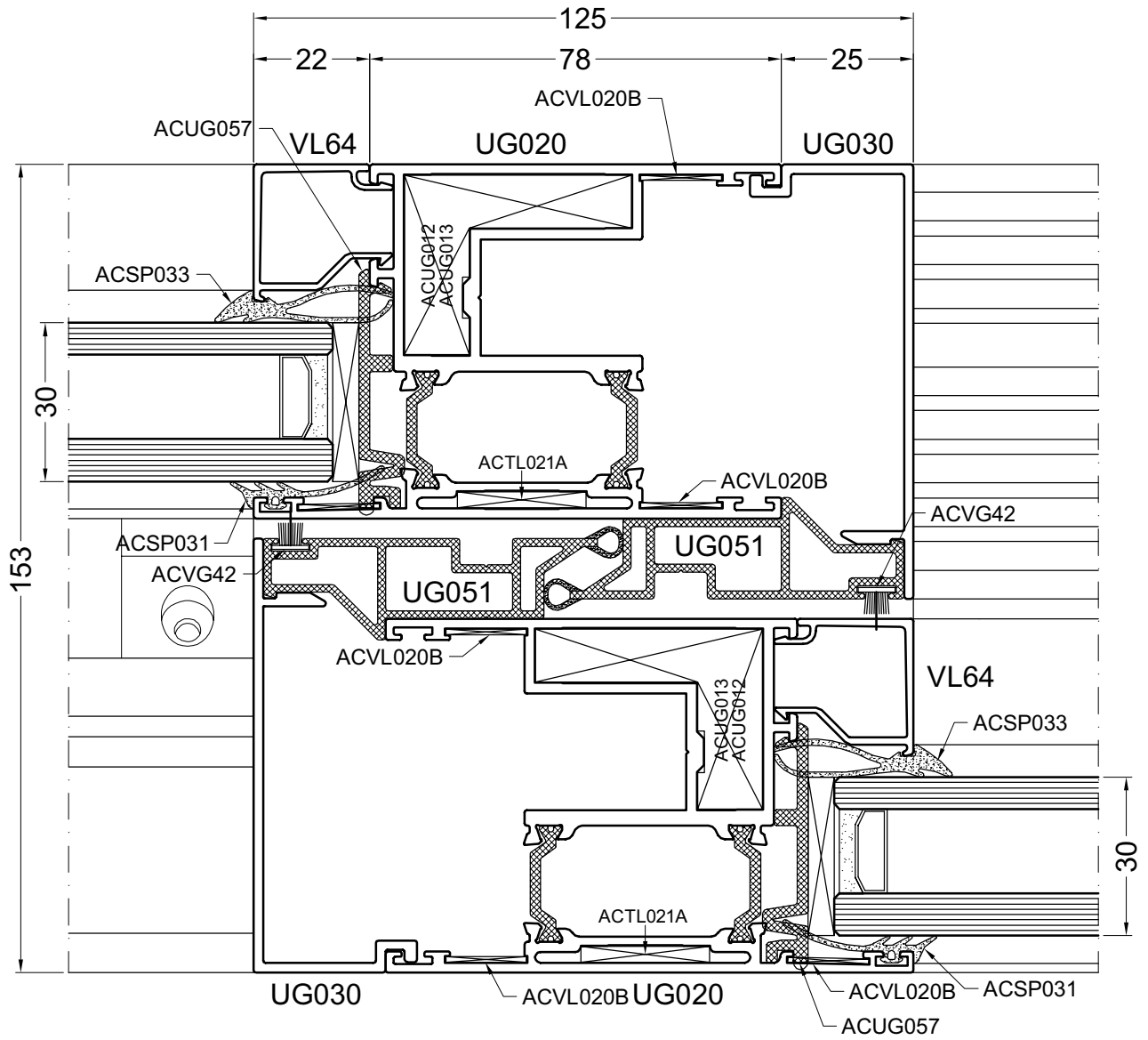

door11

11B

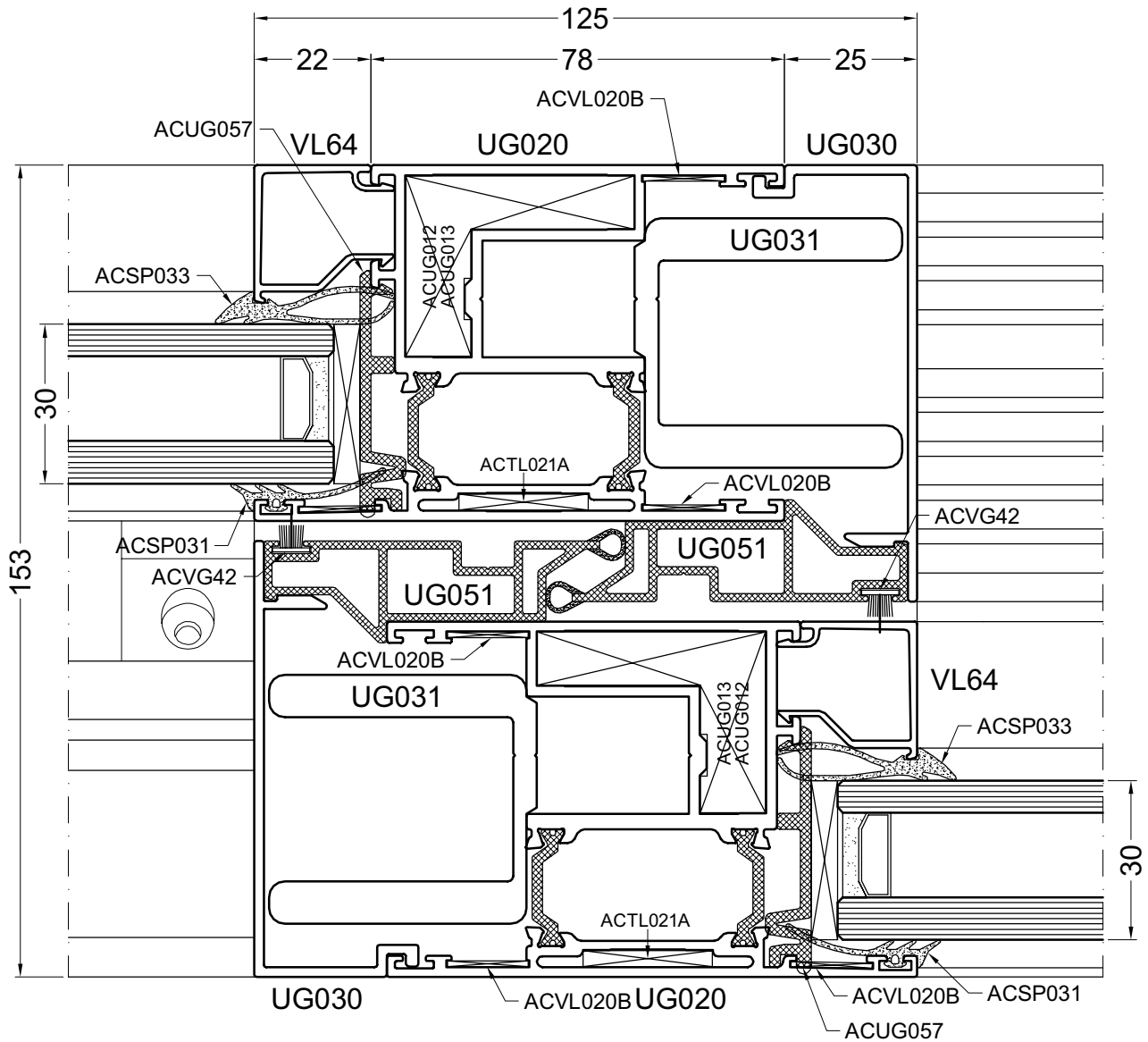

door11a

12A

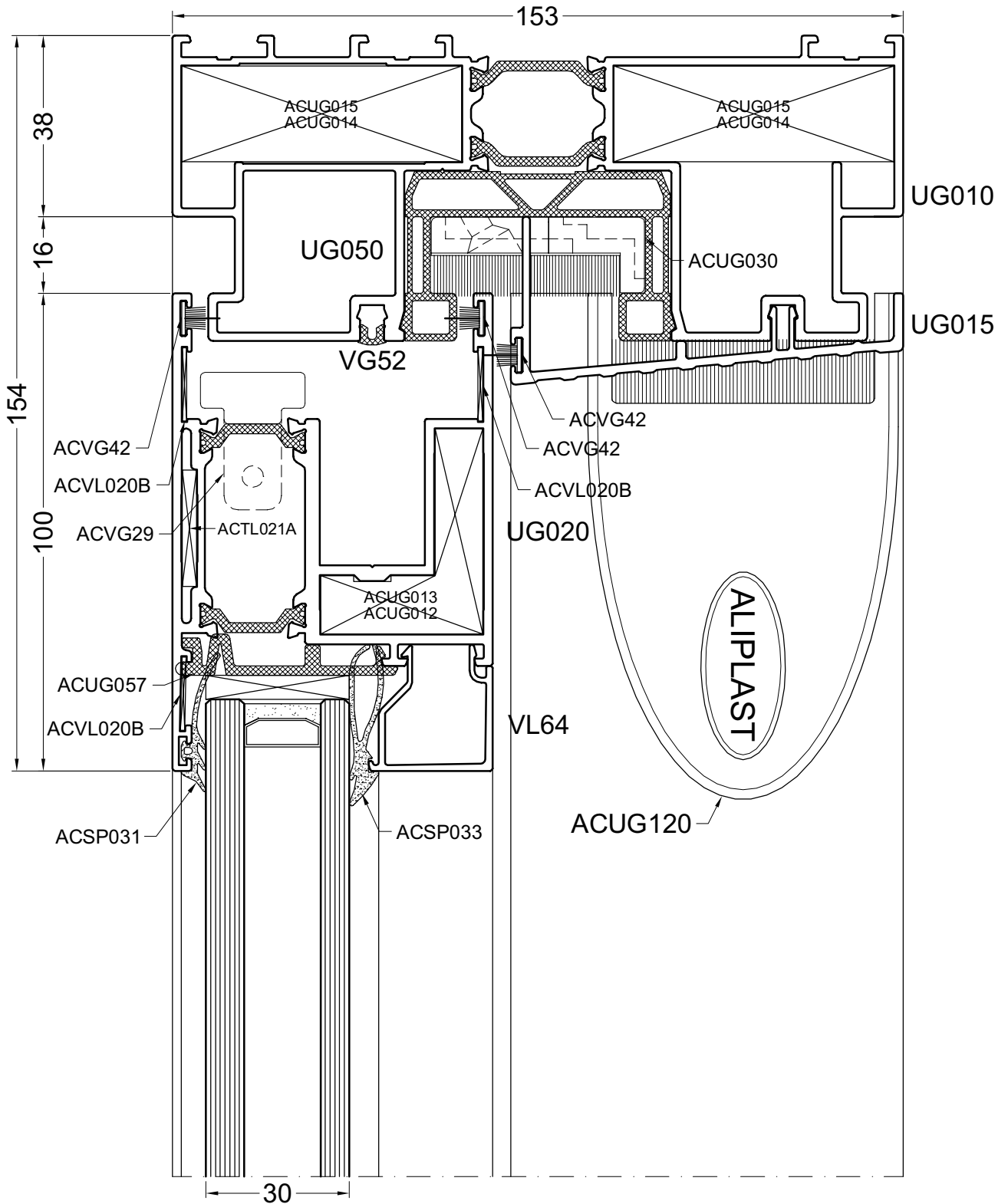

DOORSNEDE - COUPE - SCHNITT - SECTIONS

door12

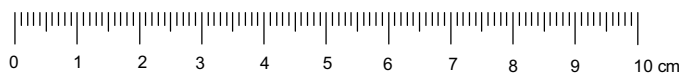

12B

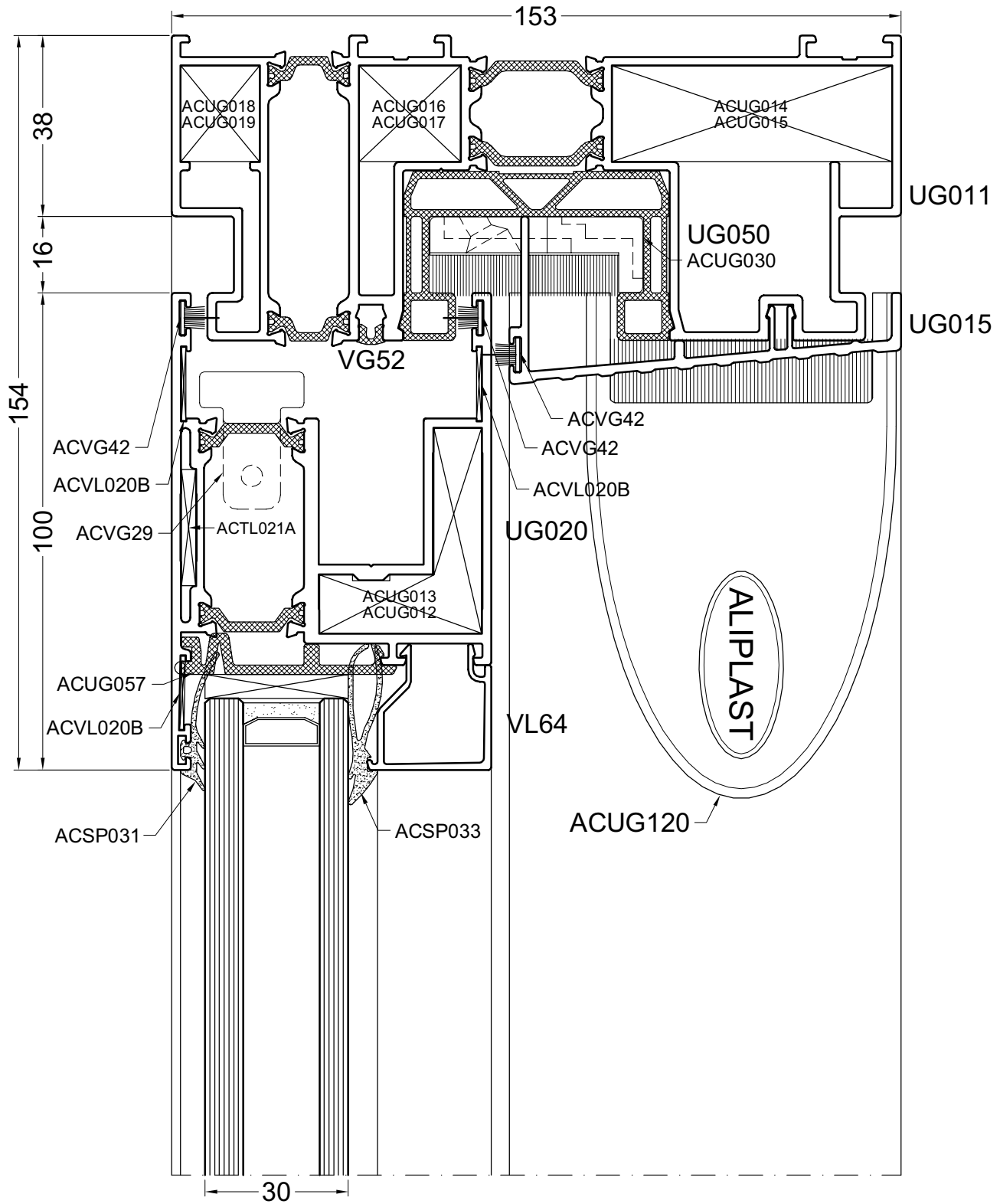

door12a

13A

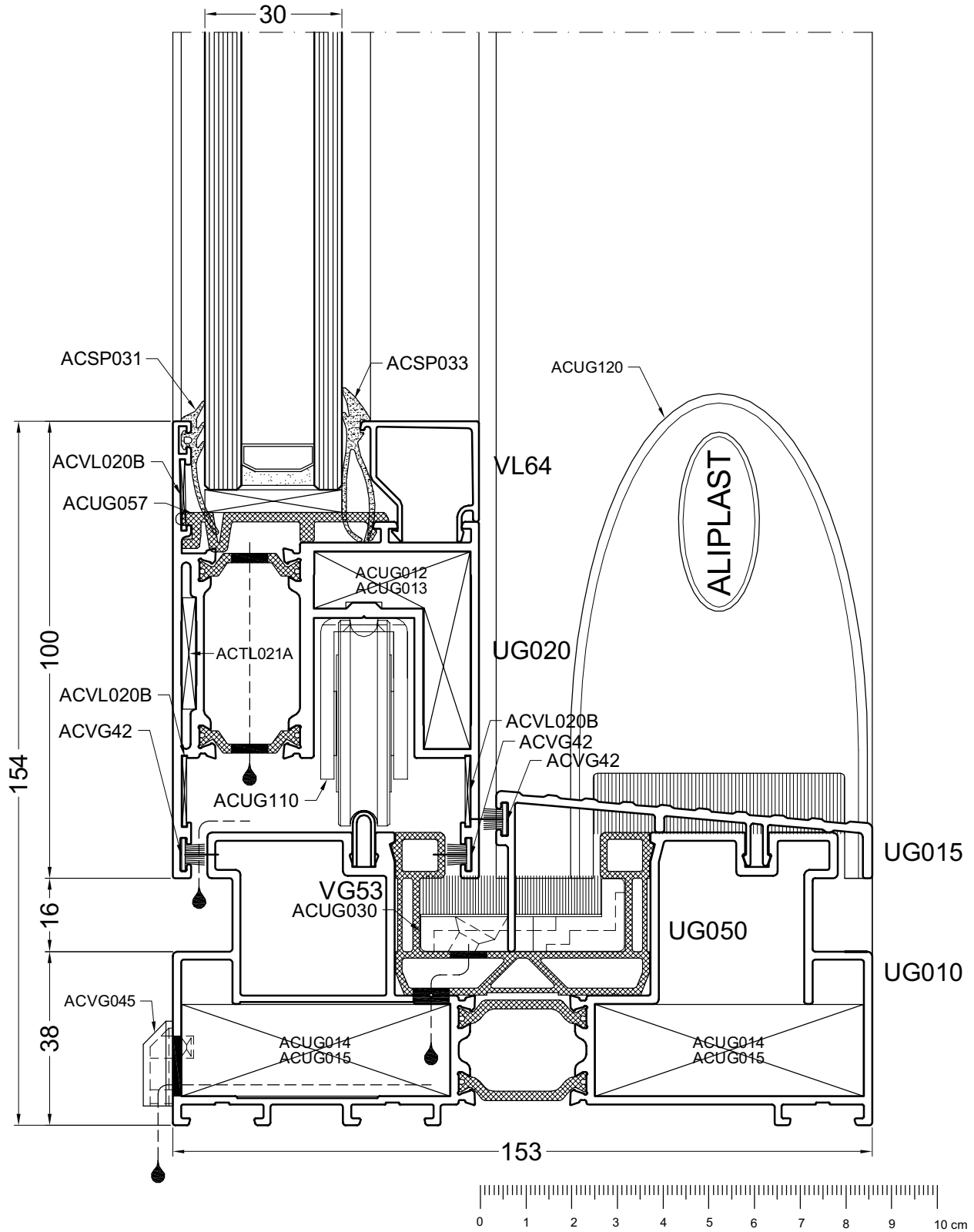

DOORSNEDE - COUPE - SCHNITT - SECTIONS

door13

13B

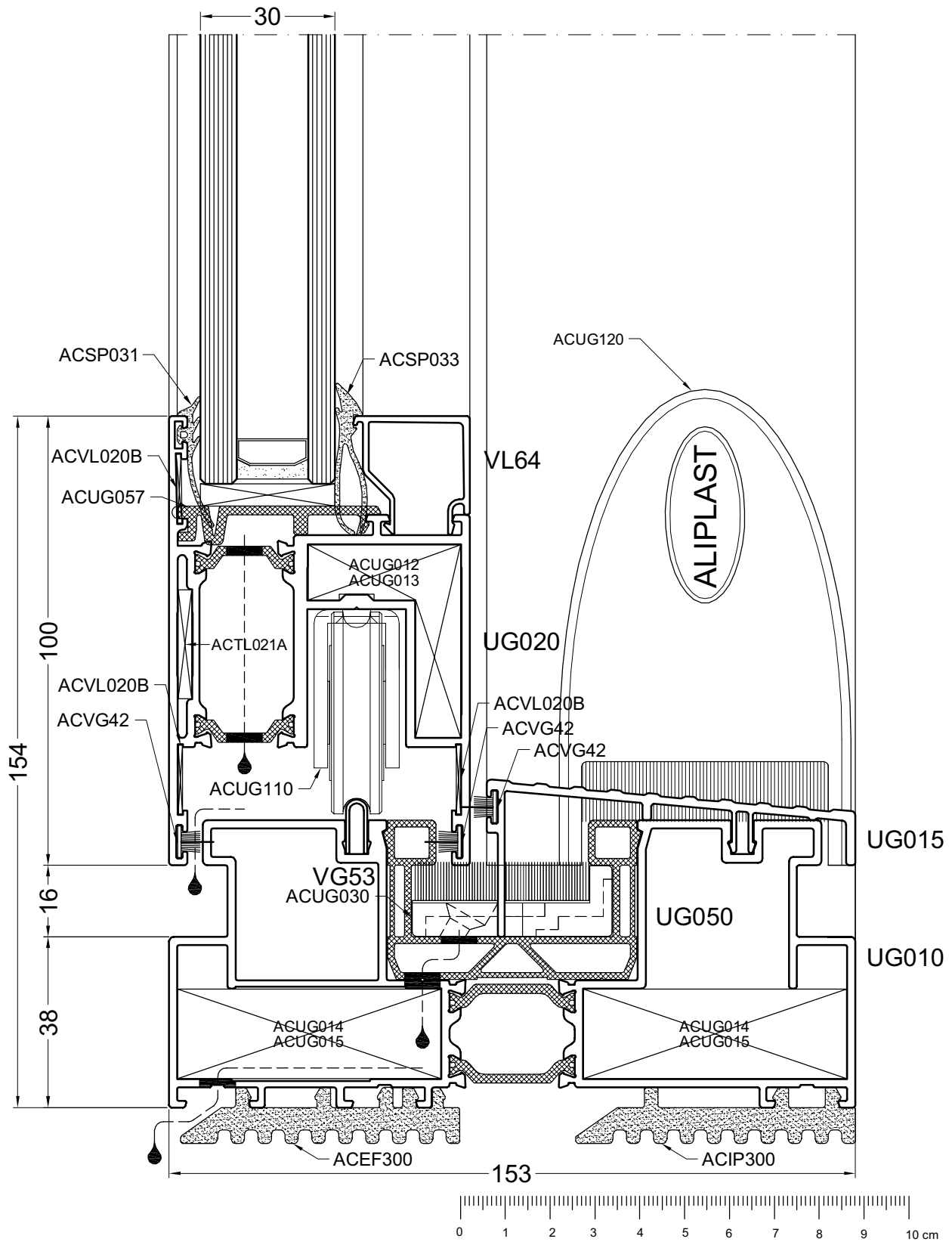

door13a

13C

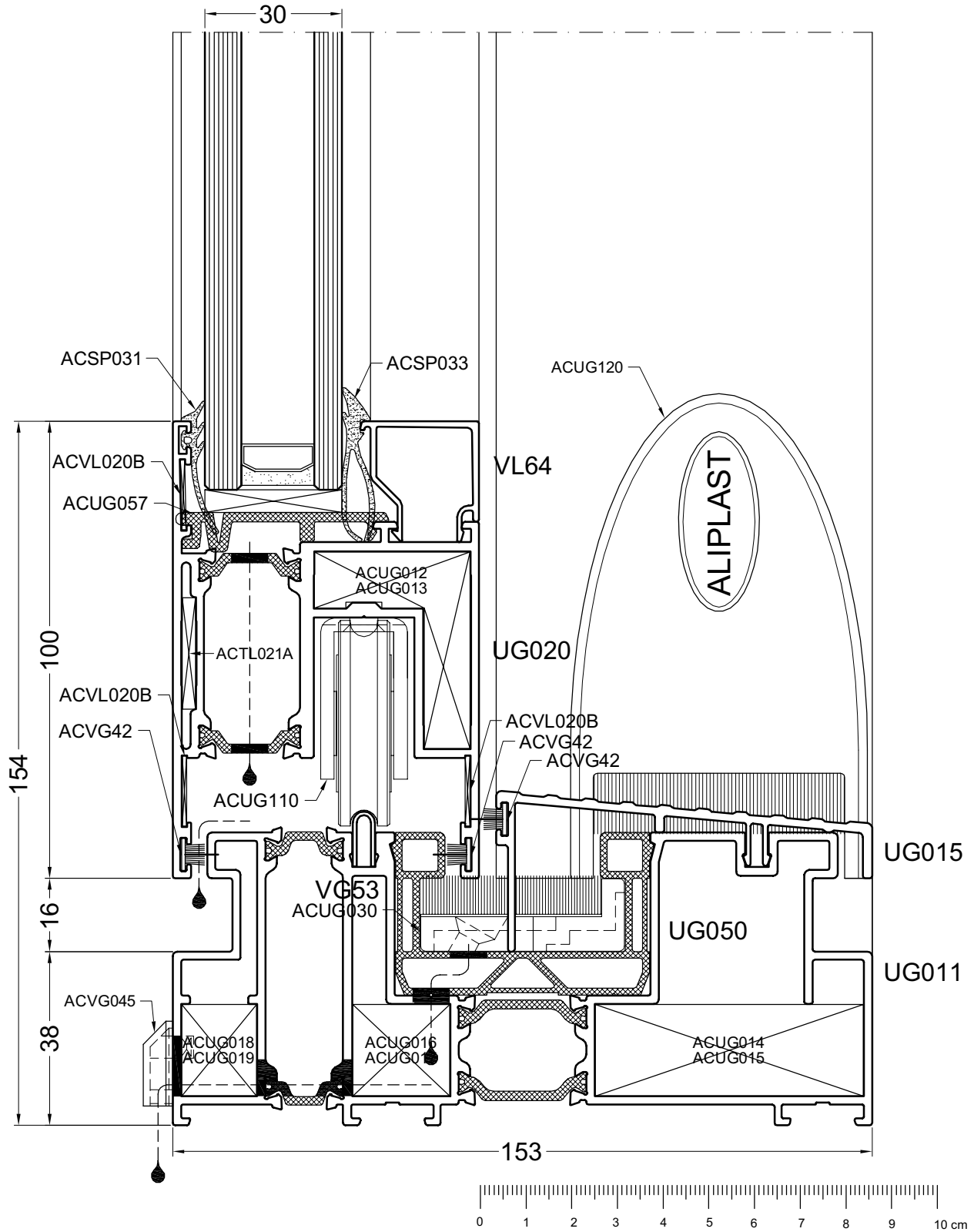

DOORSNEDE - COUPE - SCHNITT - SECTIONS

door13b

14A

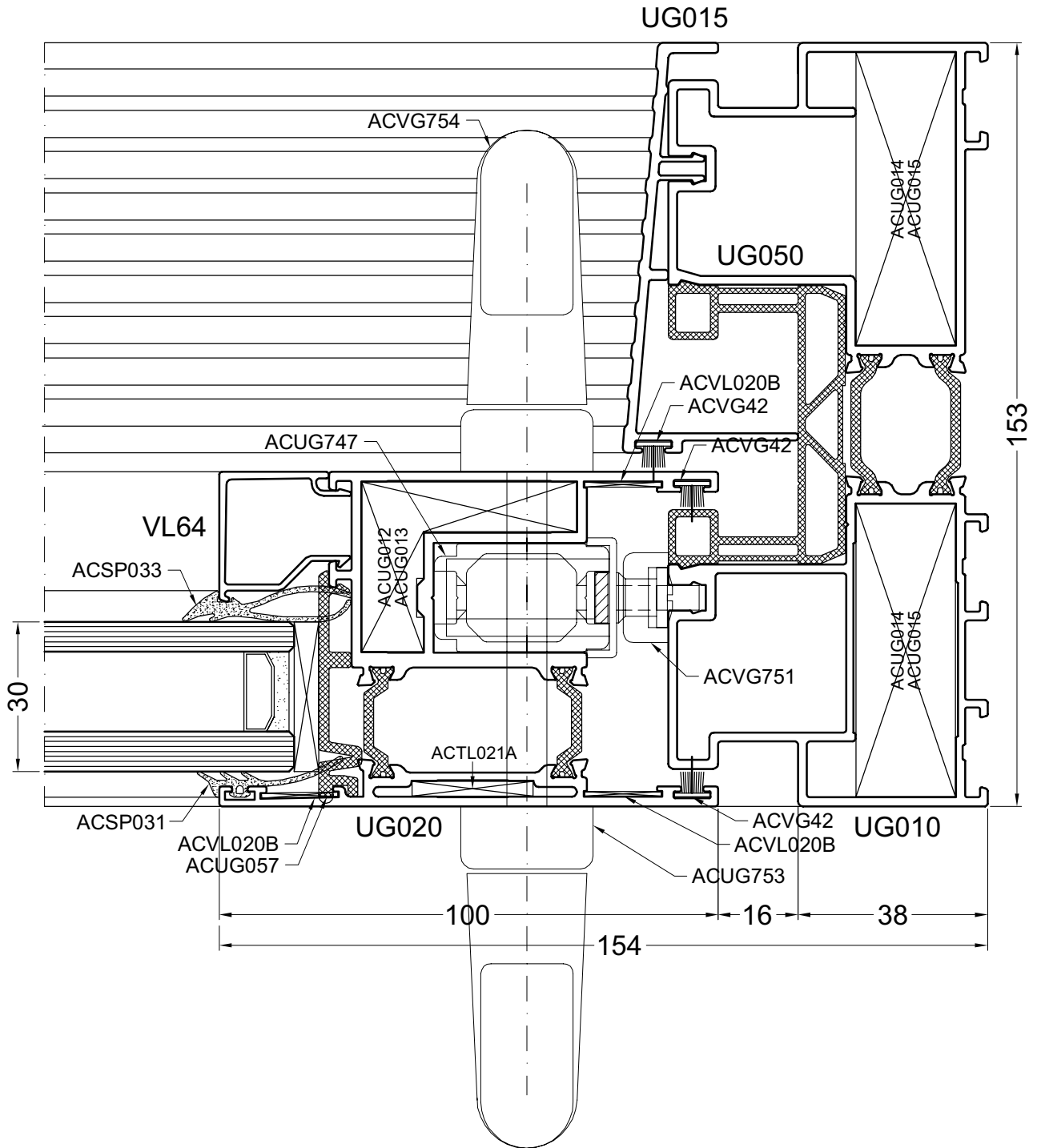

door14

14B

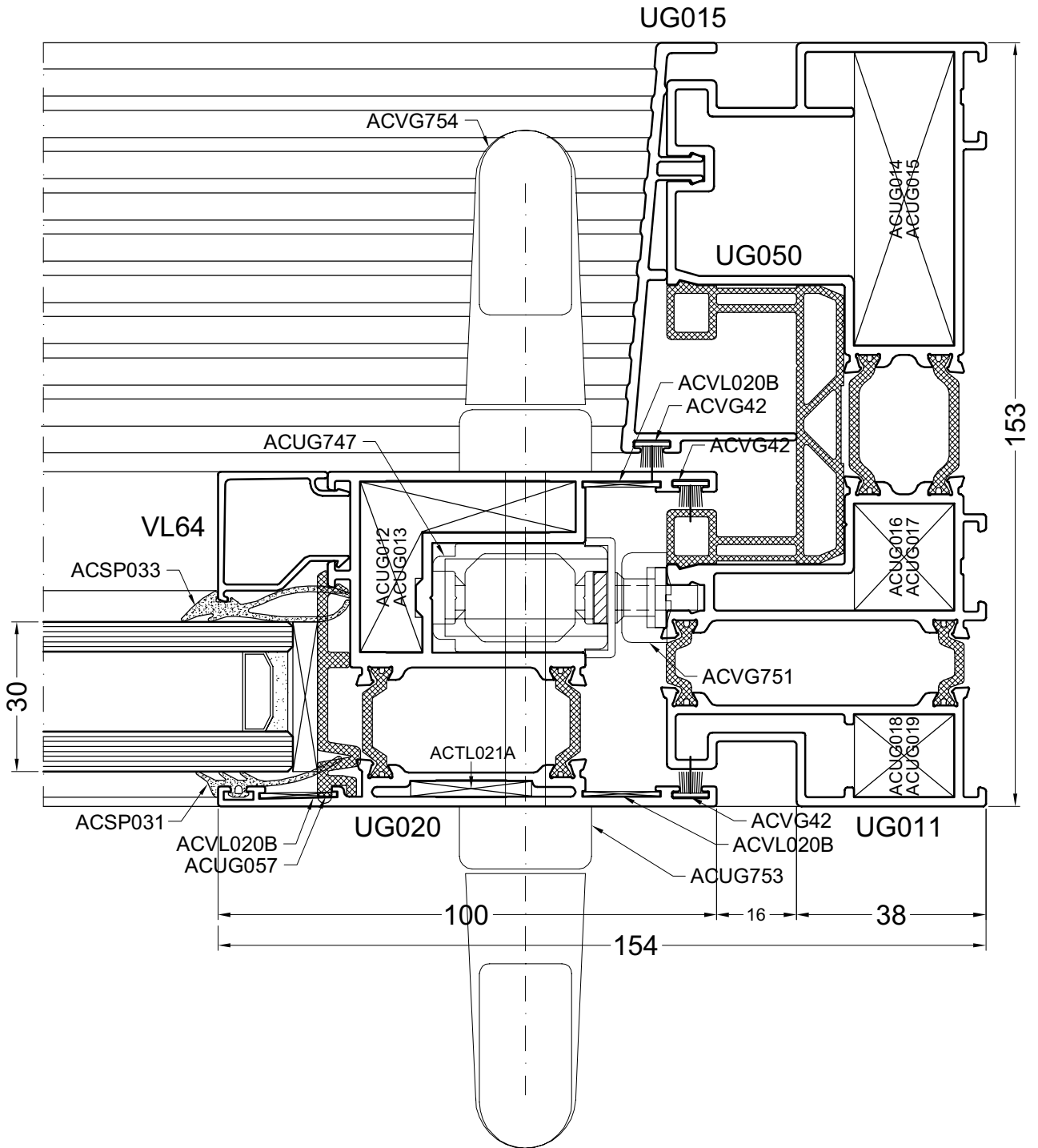

DOORSNEDE - COUPE - SCHNITT - SECTIONS

door14a

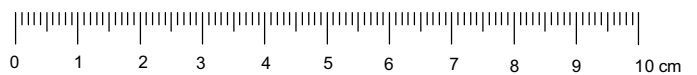

15A

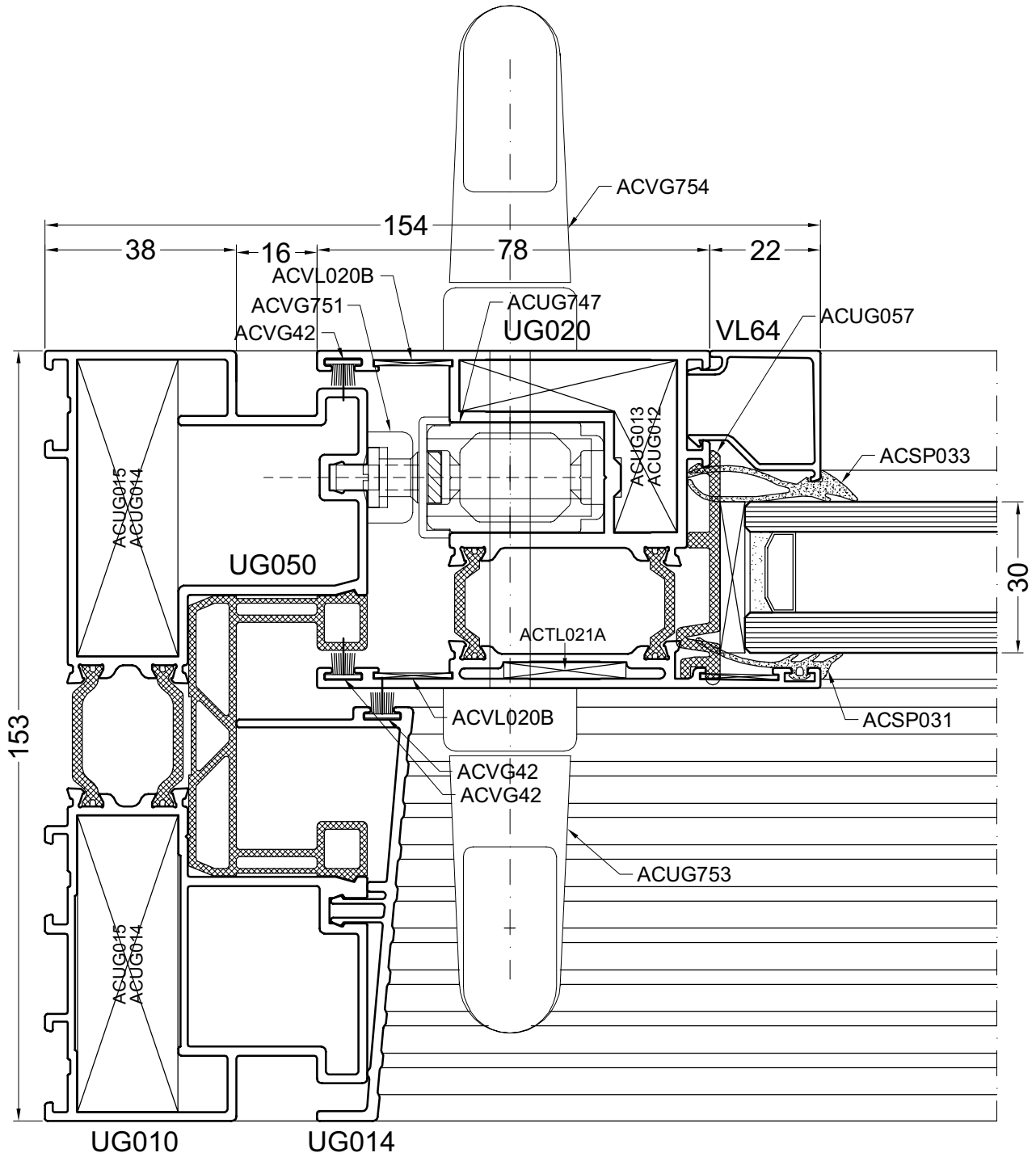

door15

15B

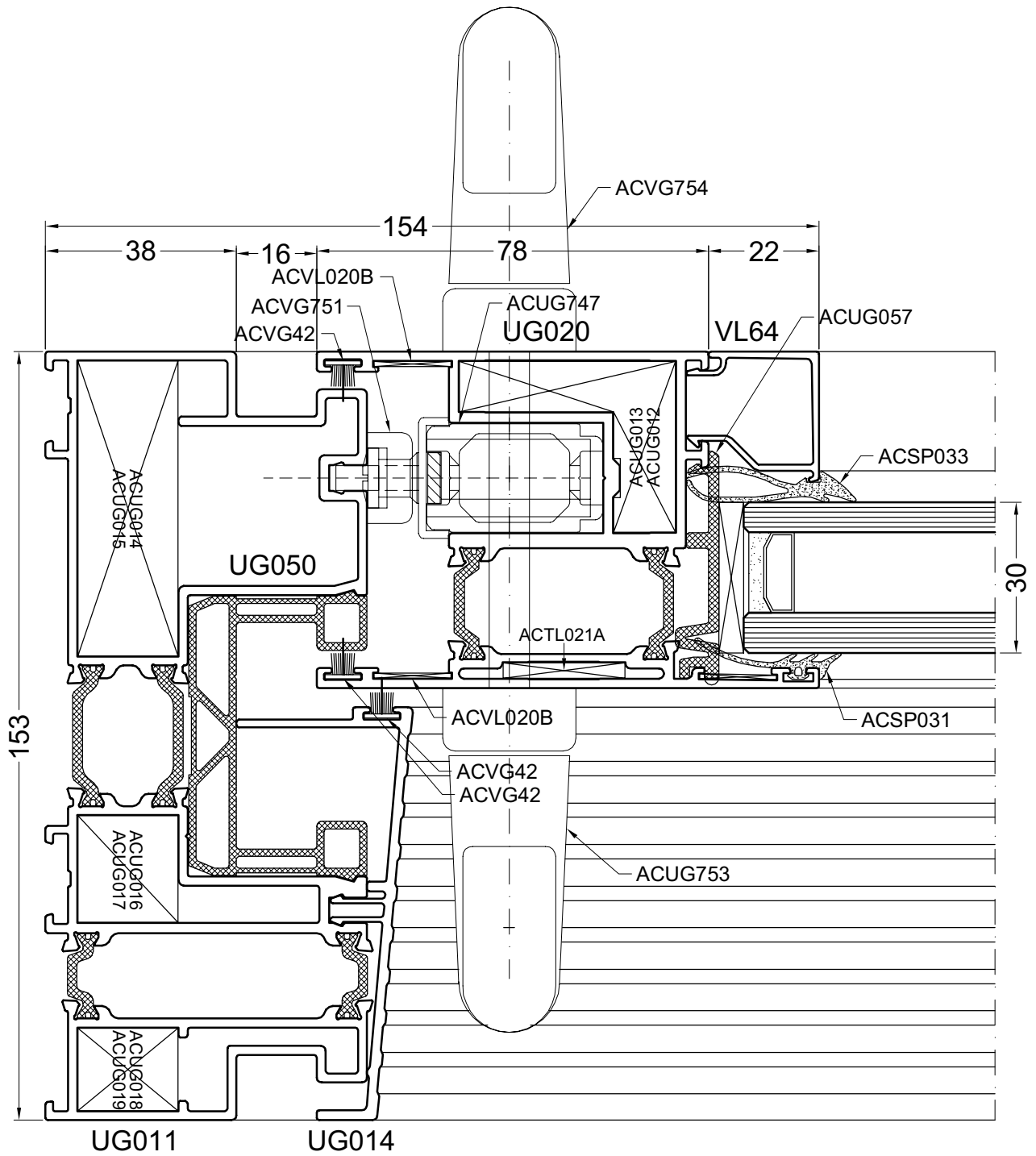

DOORSNEDE - COUPE - SCHNITT - SECTIONS

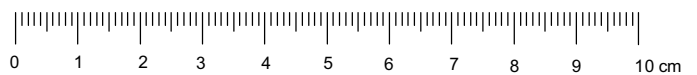

door15a

16A

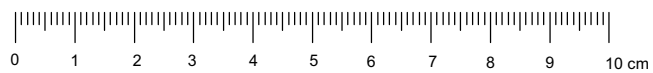
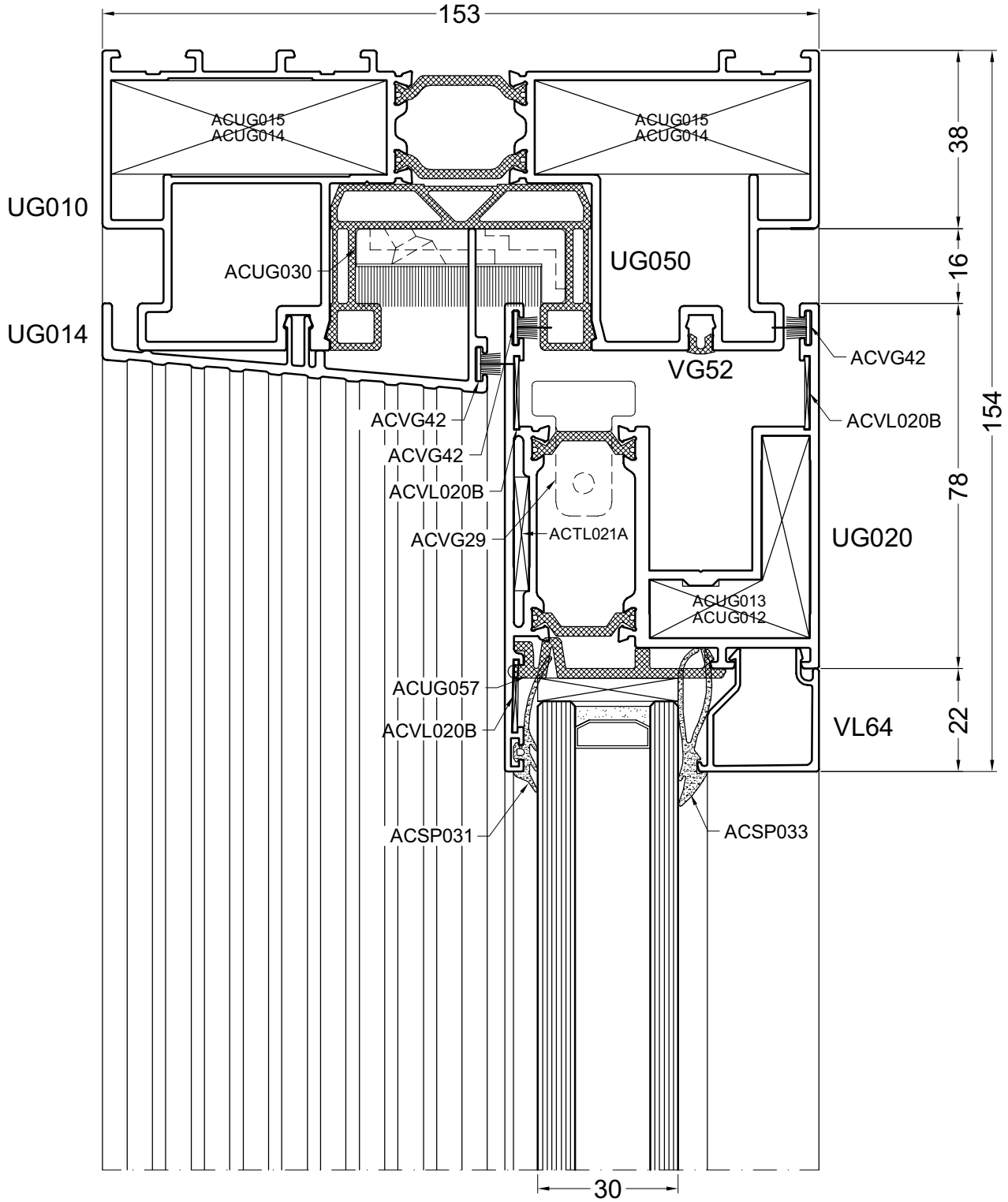

door16

16B

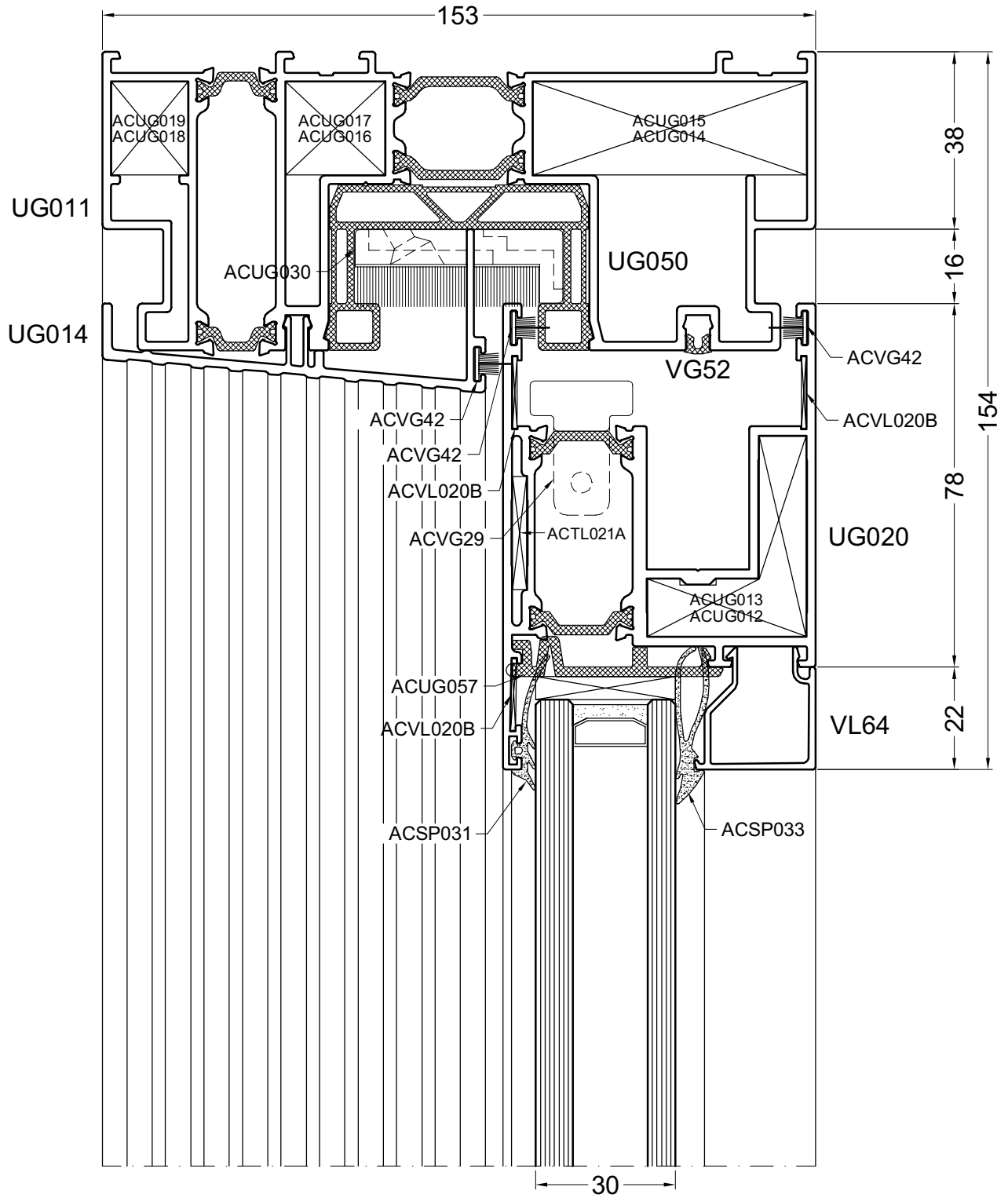

DOORSNEDE - COUPE - SCHNITT - SECTIONS



door16a

17A

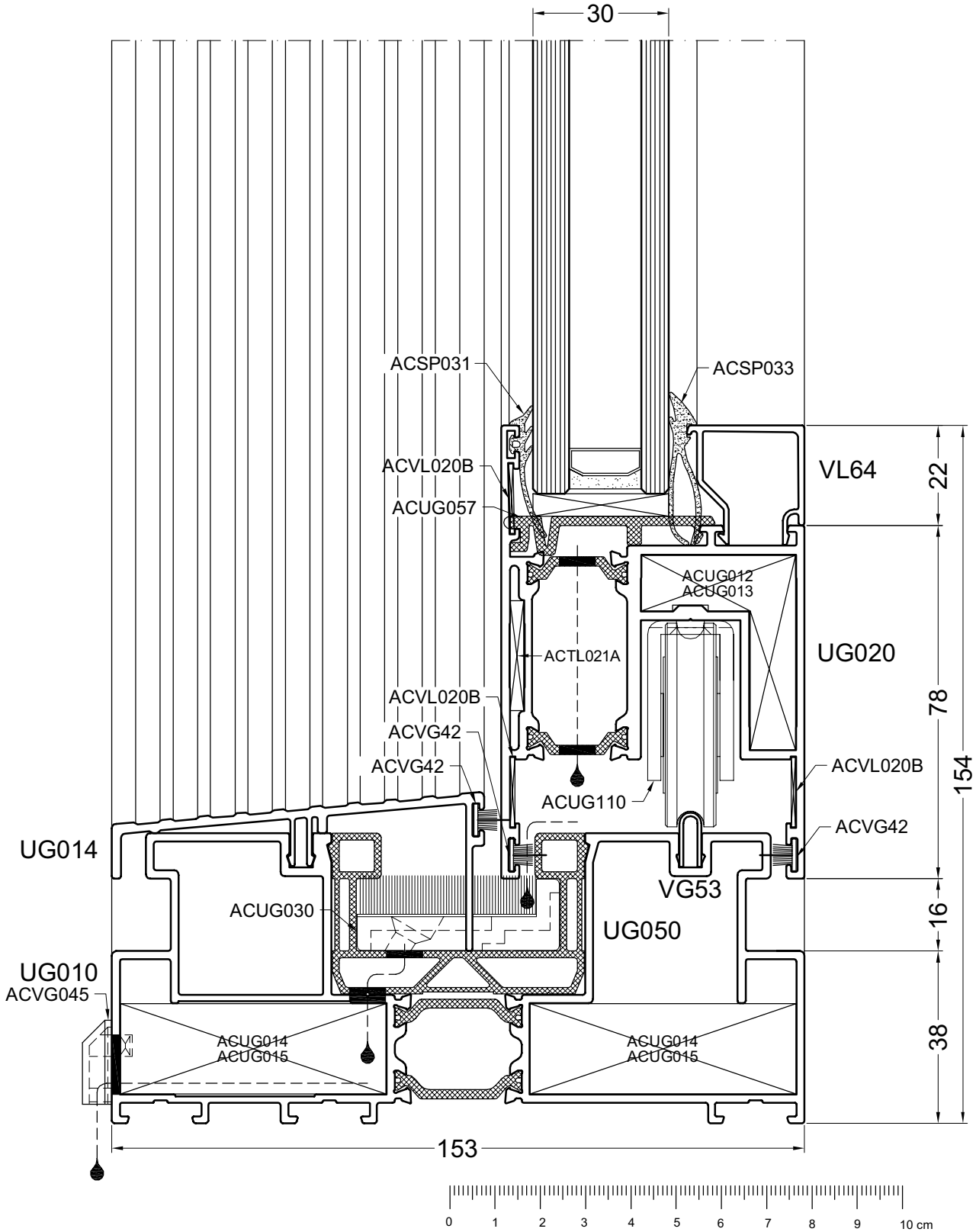

door17

17B

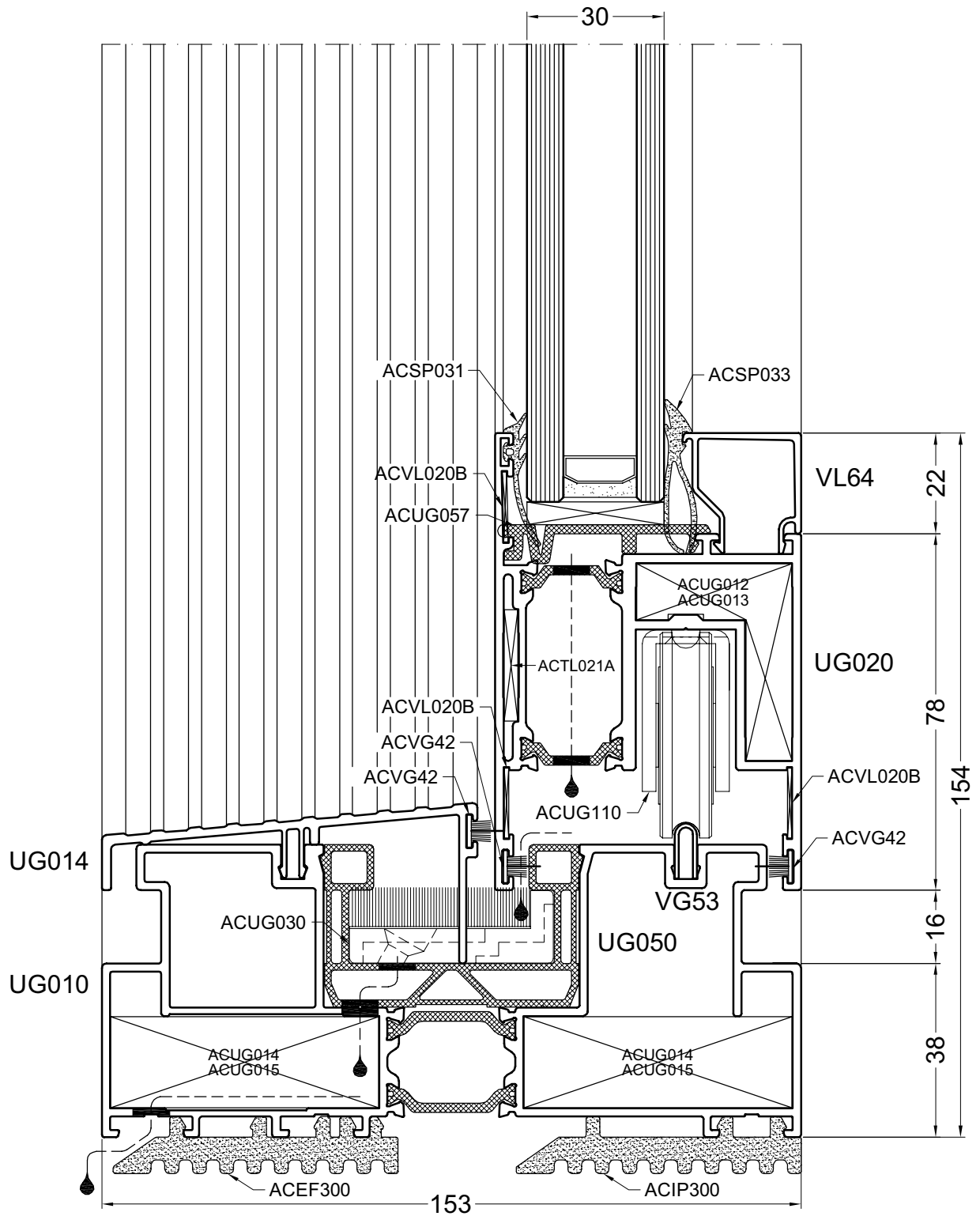

DOORSNEDE - COUPE - SCHNITT - SECTIONS



door17a

17C

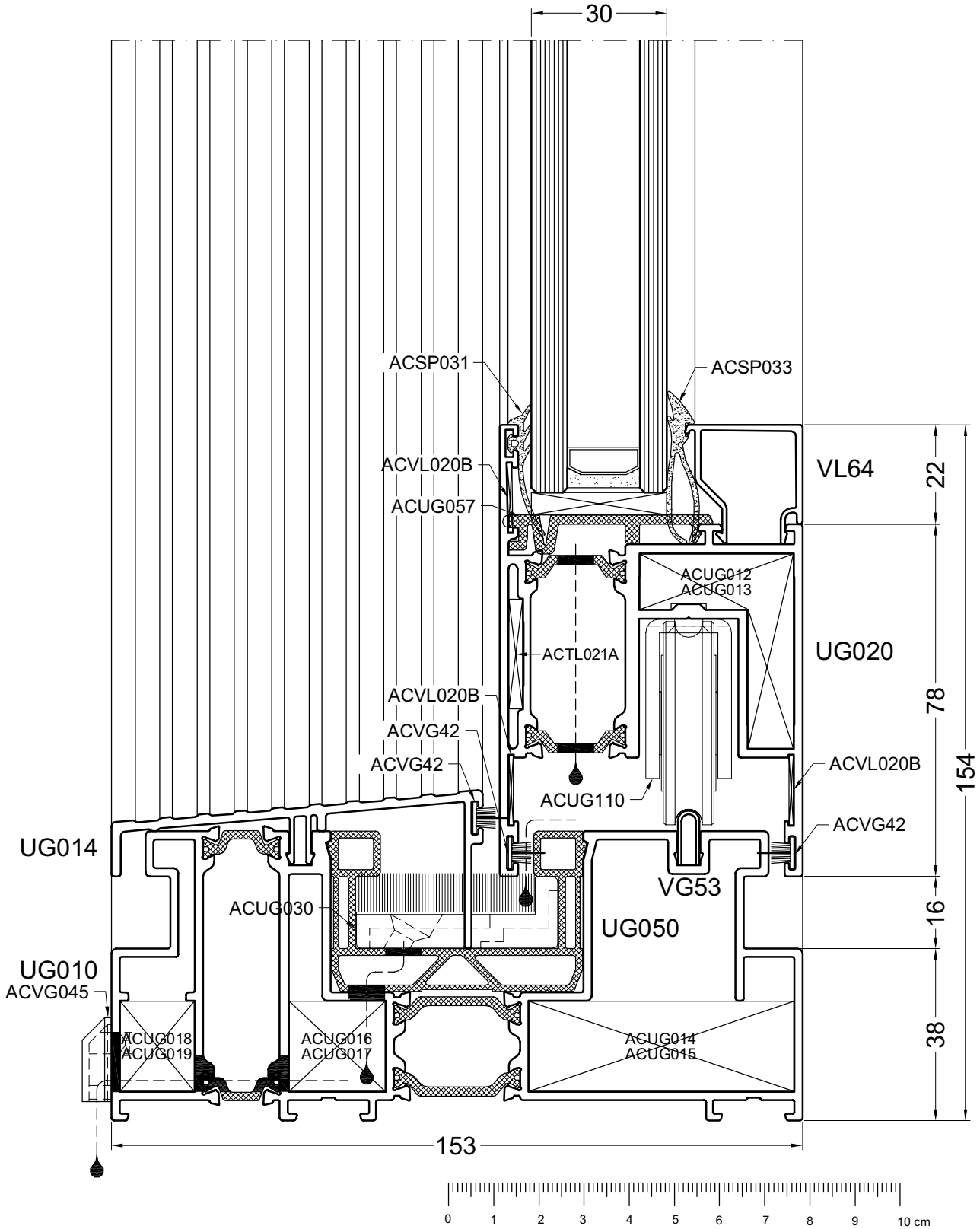

door17b

18A

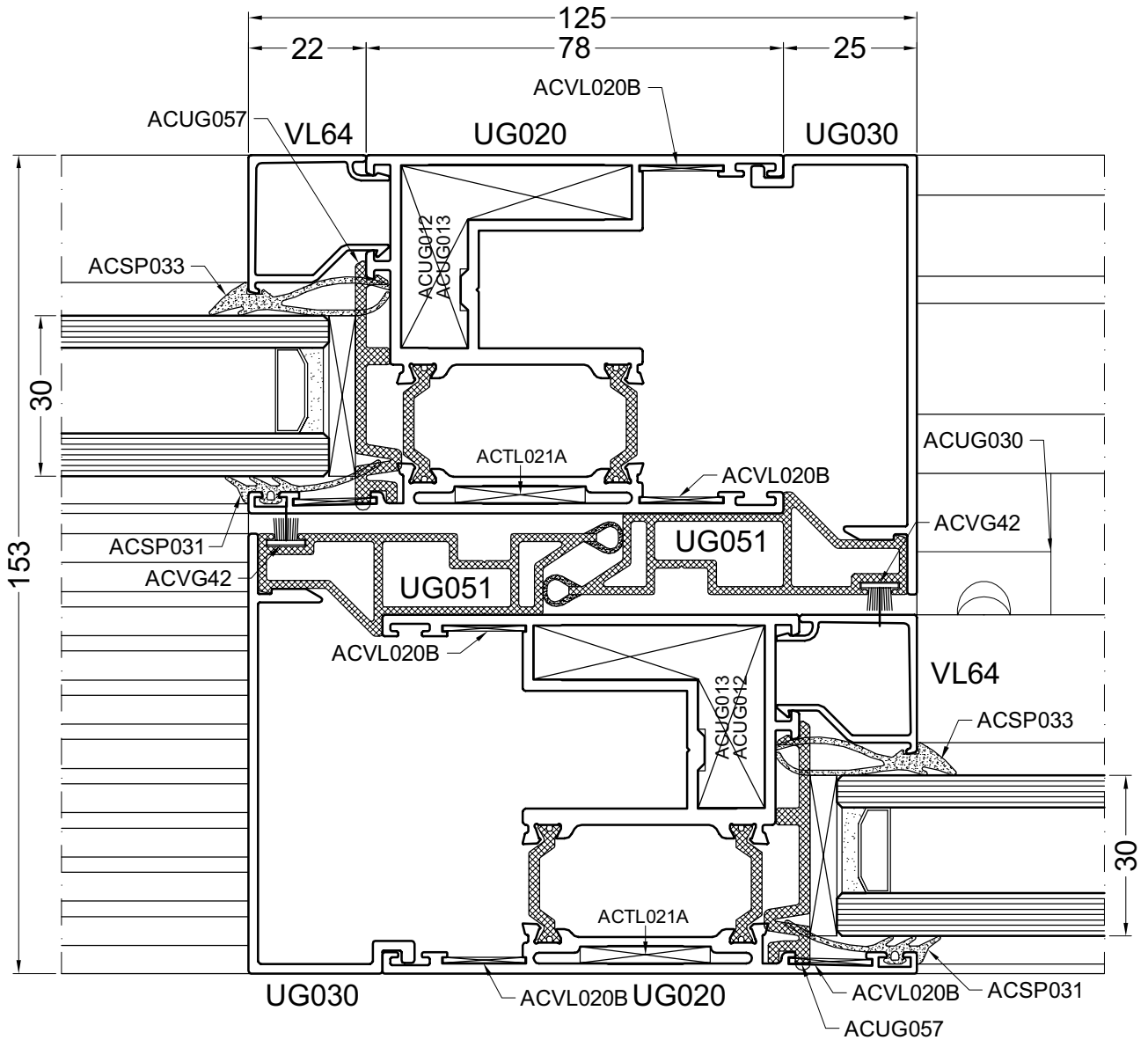

door18



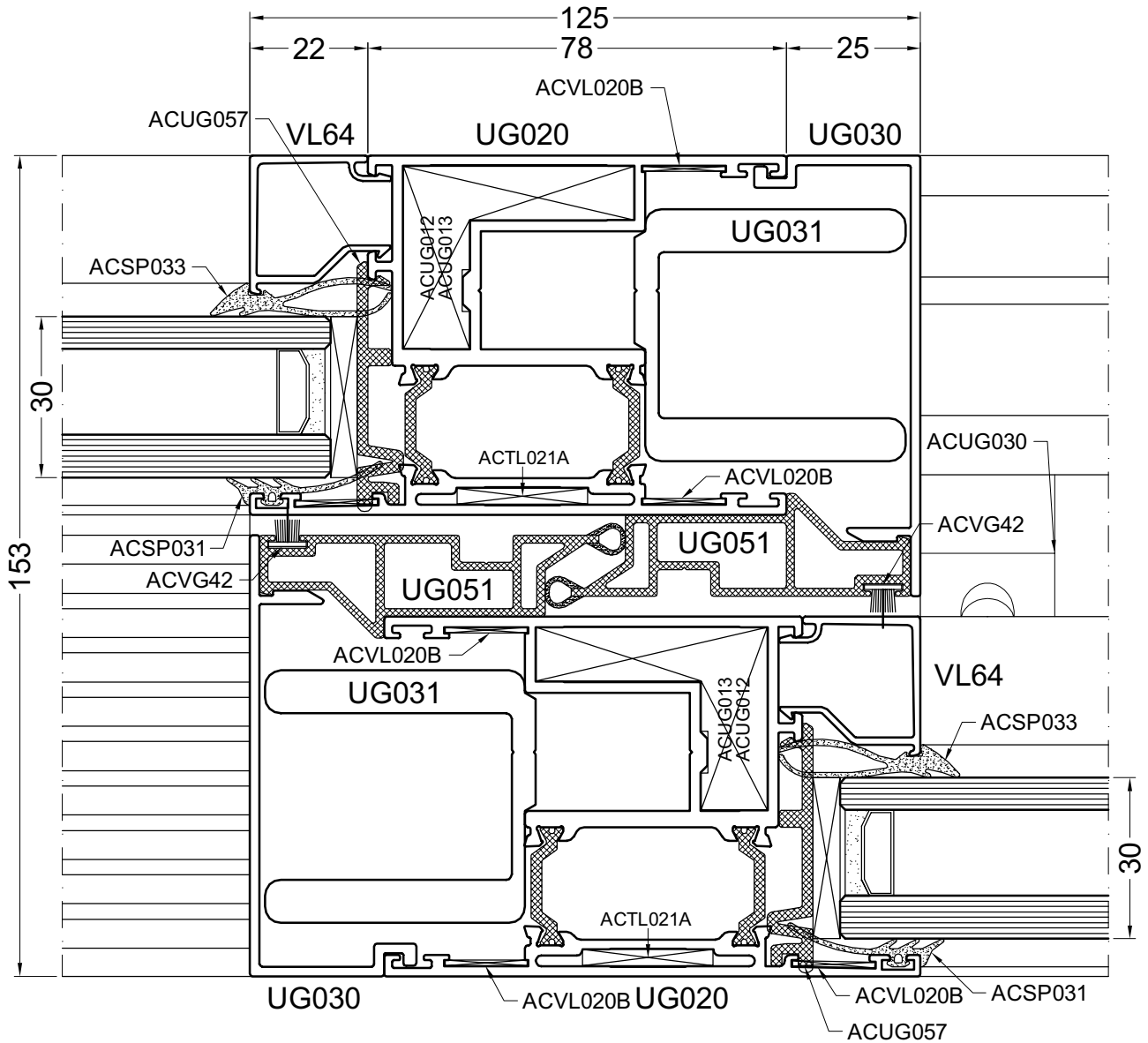

door18a

19A

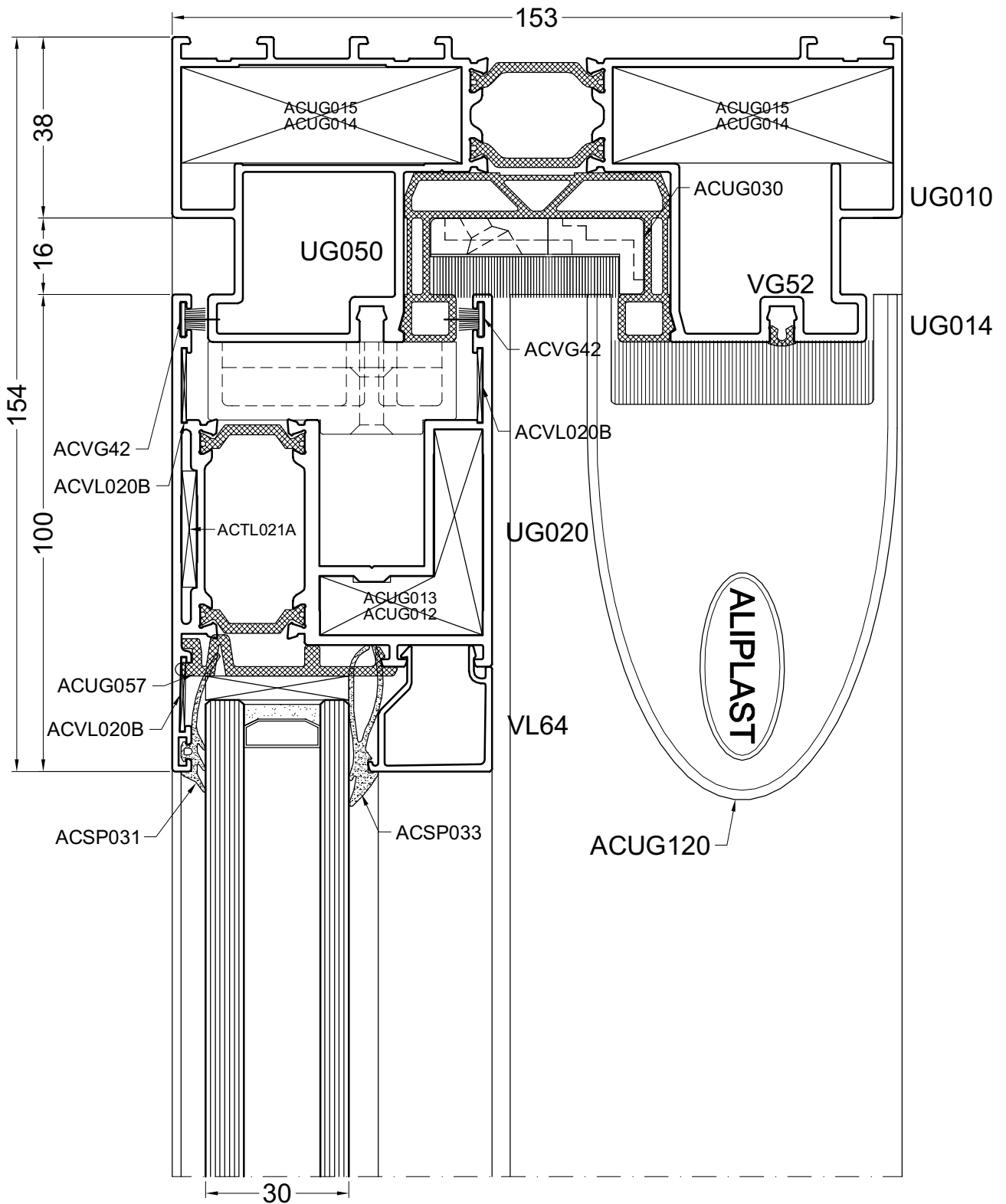

DOORSNEDE - COUPE - SCHNITT - SECTIONS

door19



19B

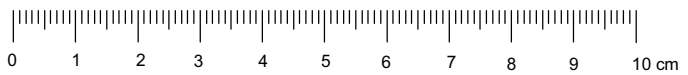
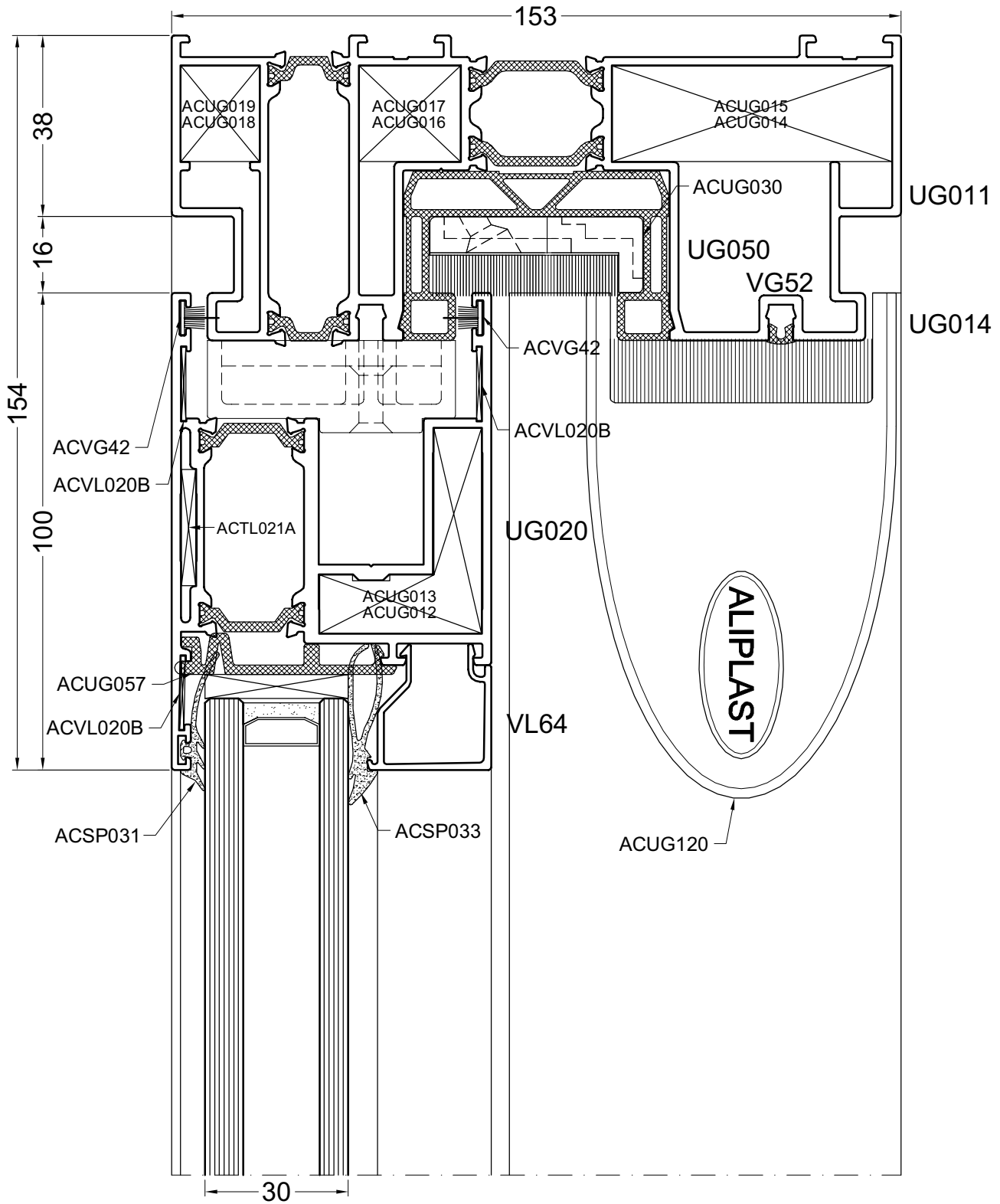

door19a

20A

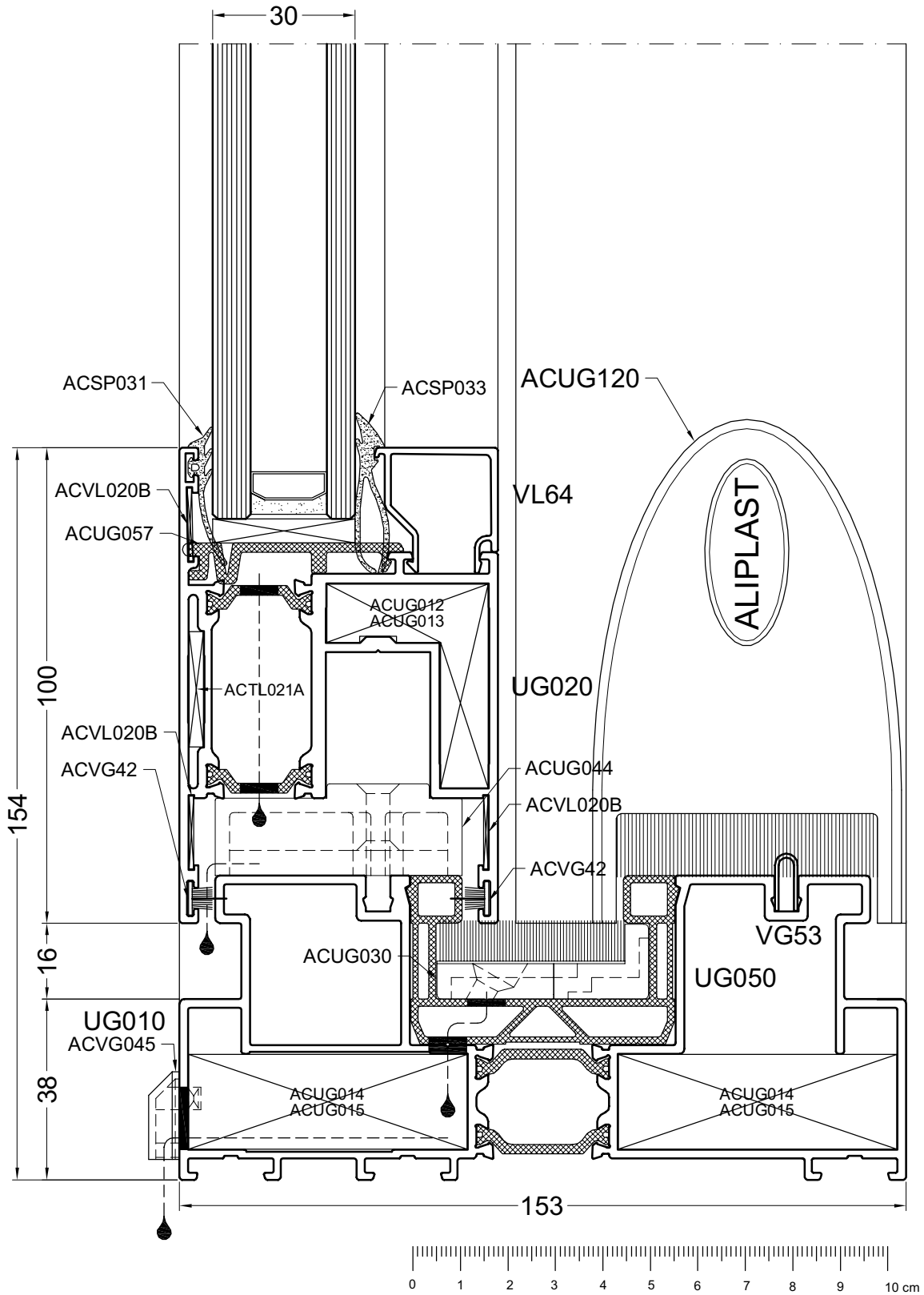

DOORSNEDE - COUPE - SCHNITT - SECTIONS

door20

20B

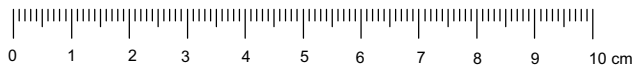
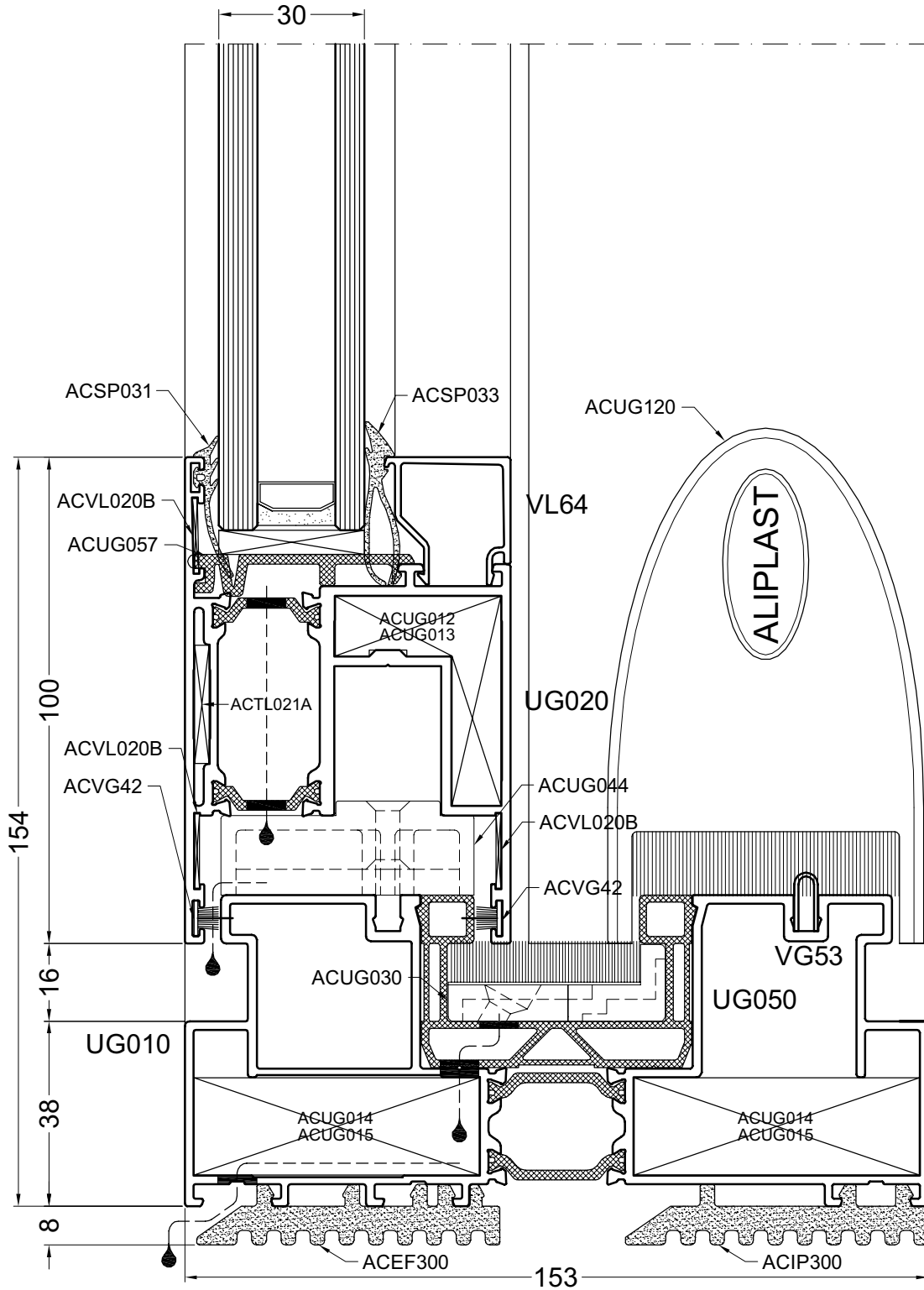

door20a

20C

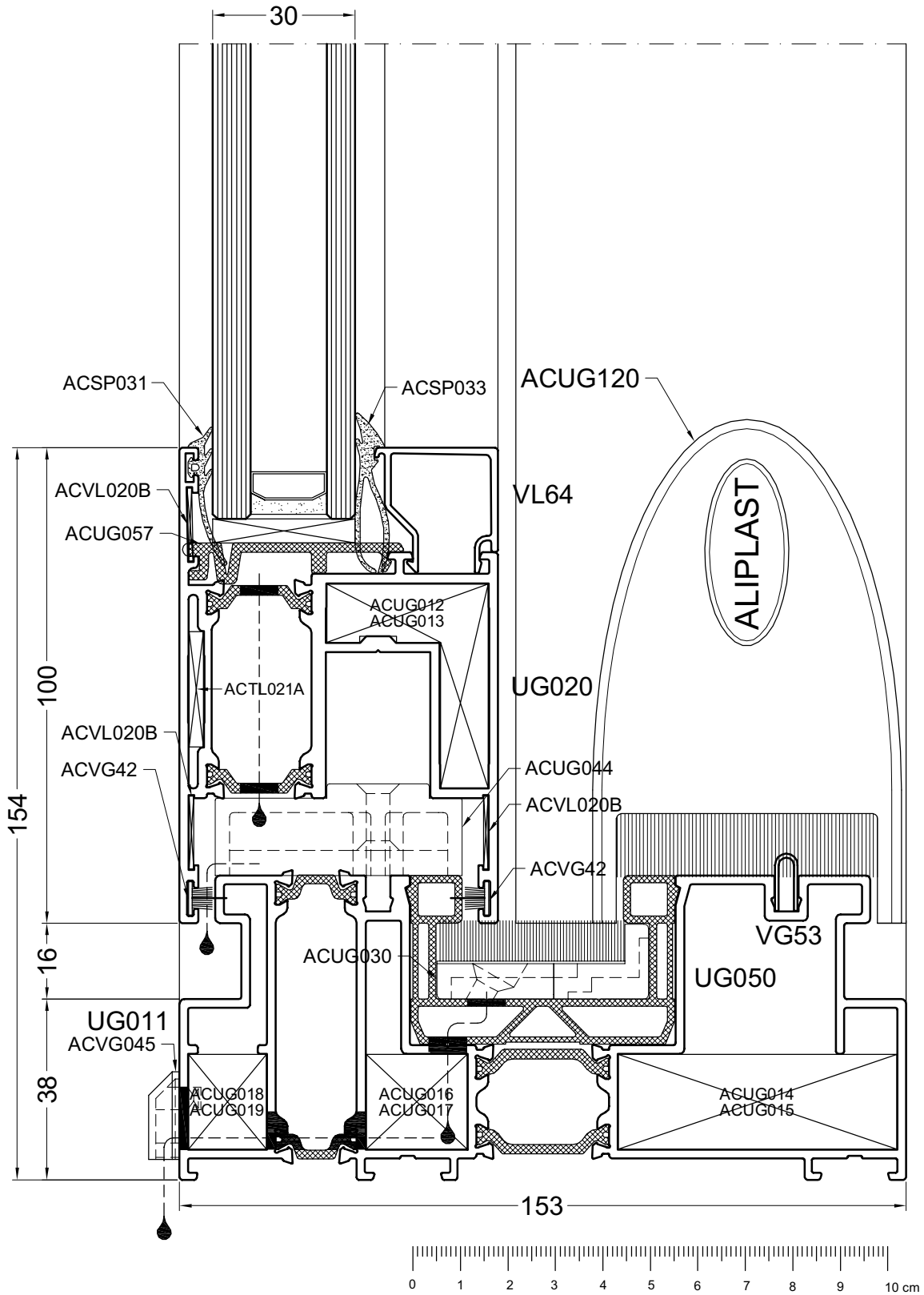

DOORSNEDE - COUPE - SCHNITT - SECTIONS

door20b

21A

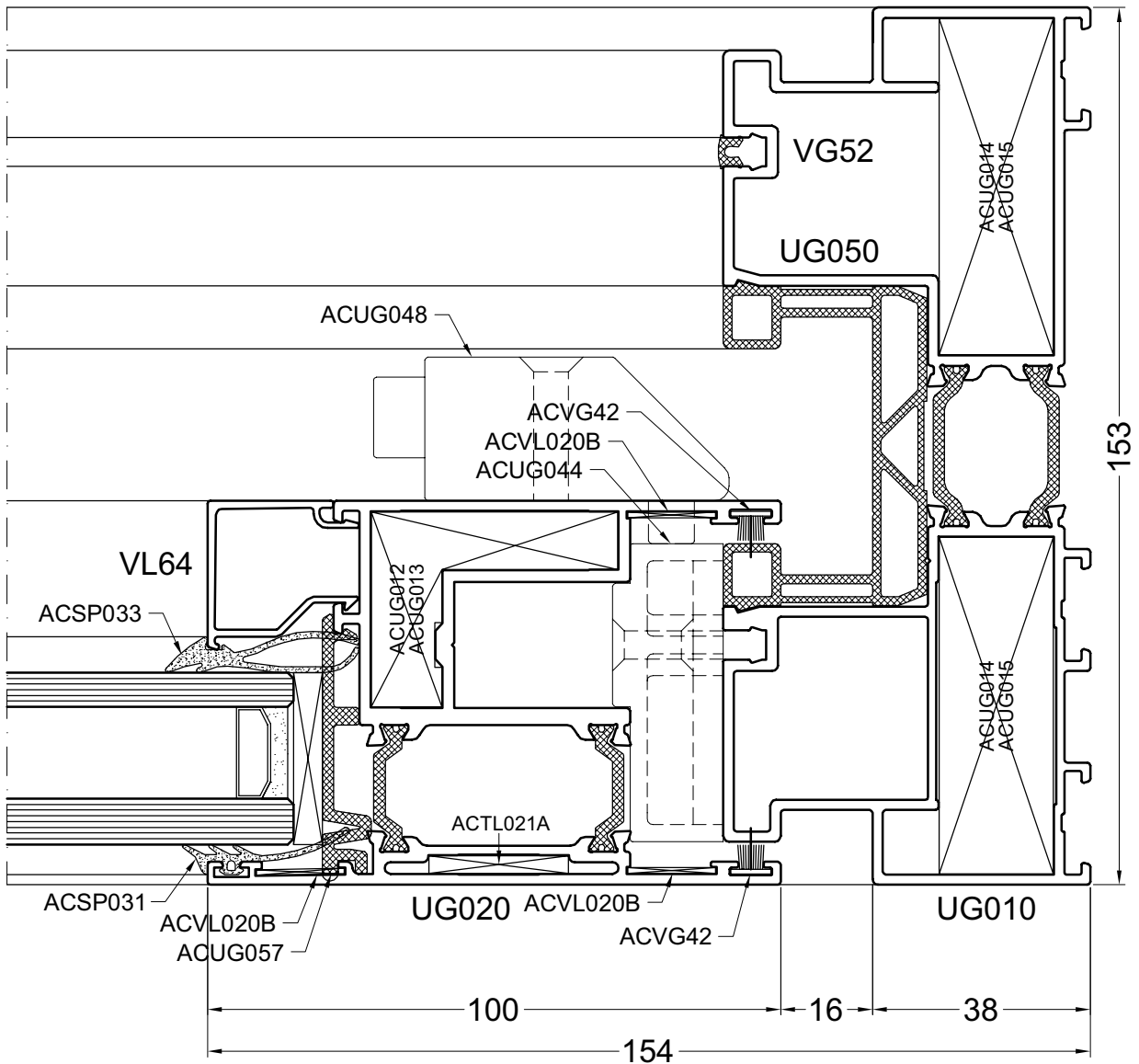

door21



21B

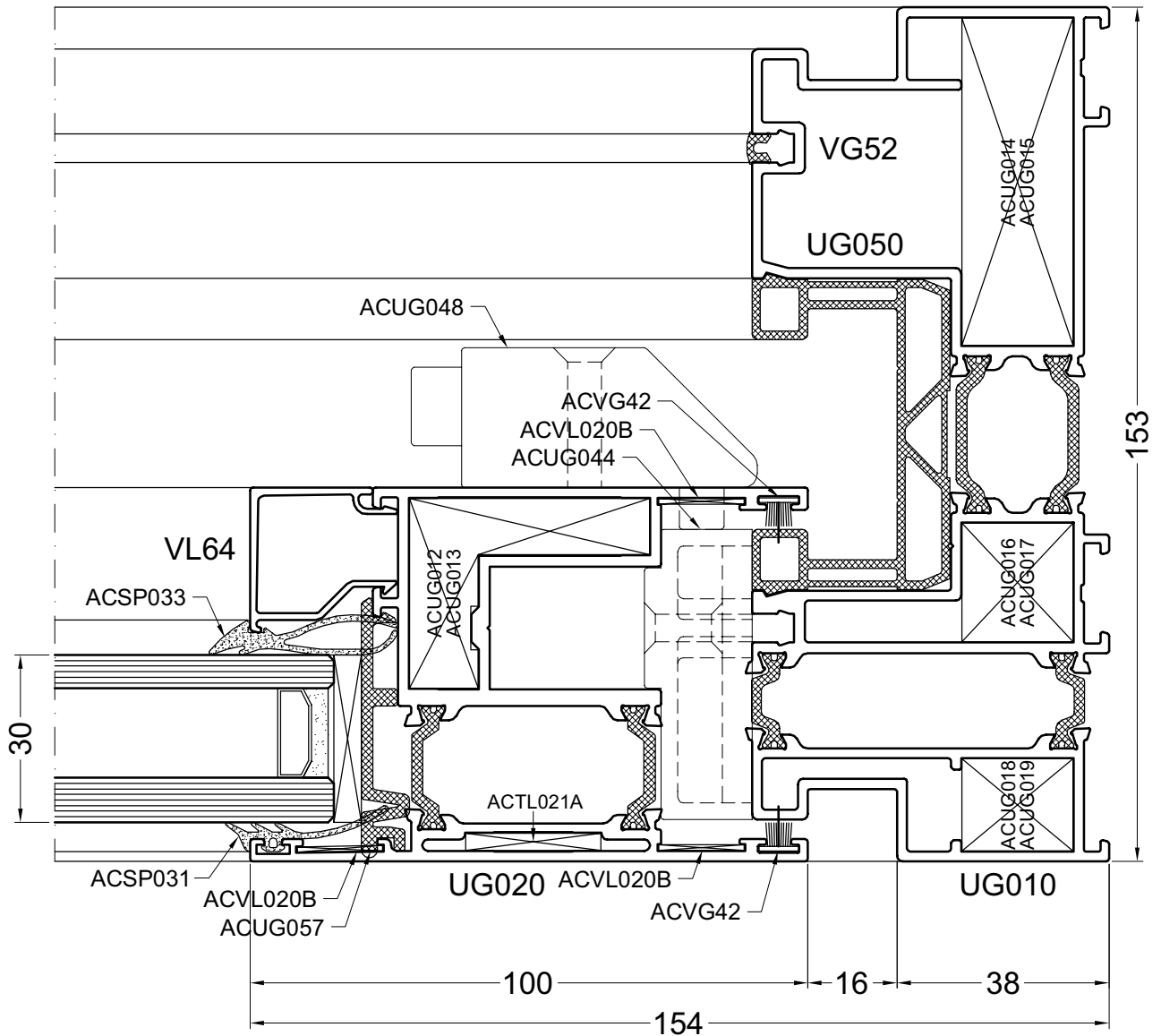

door21a

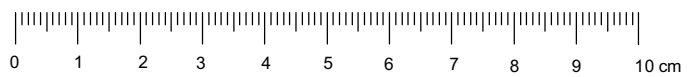

22A

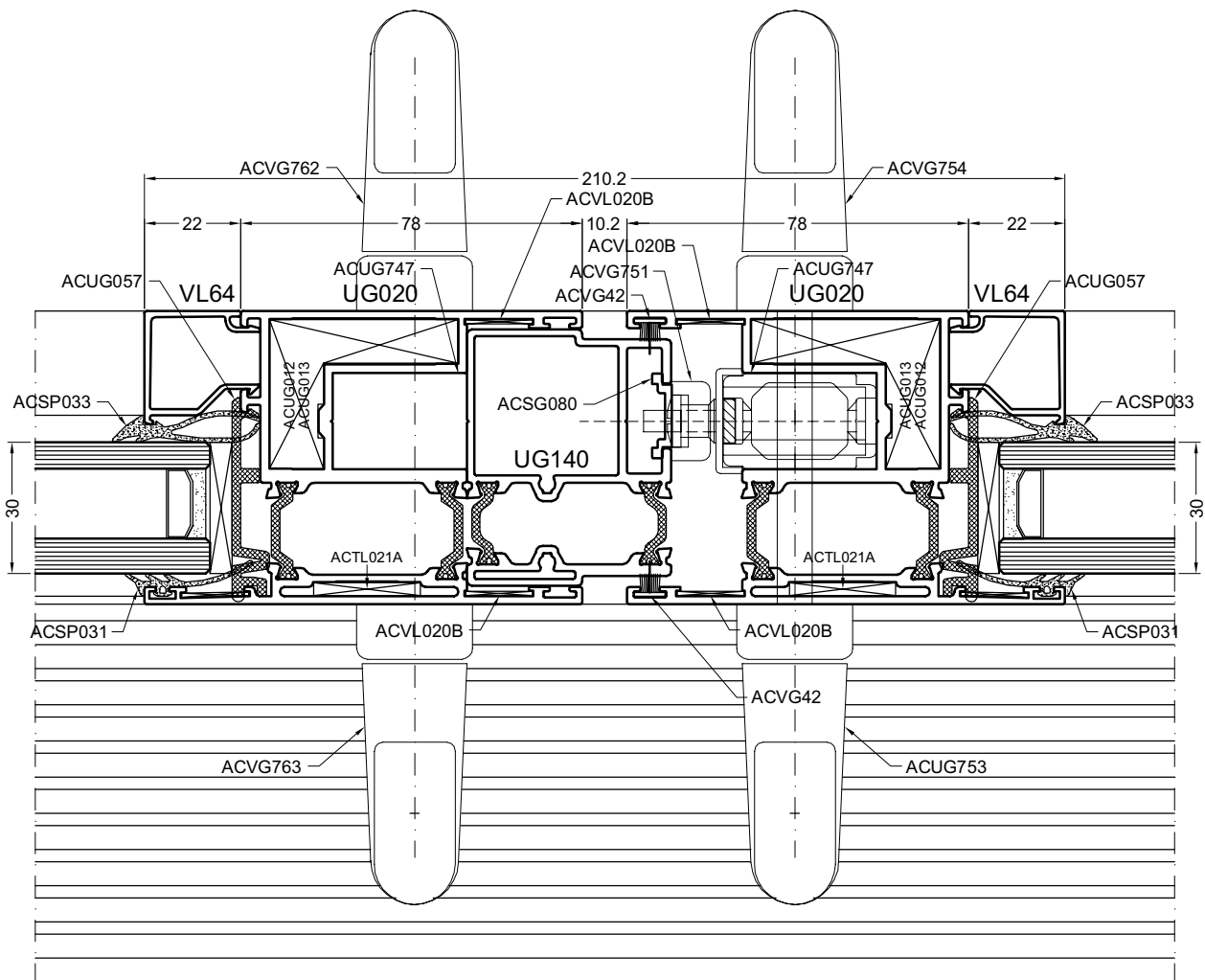

door22

22B

DOORSNEDE - COUPE - SCHNITT - SECTIONS

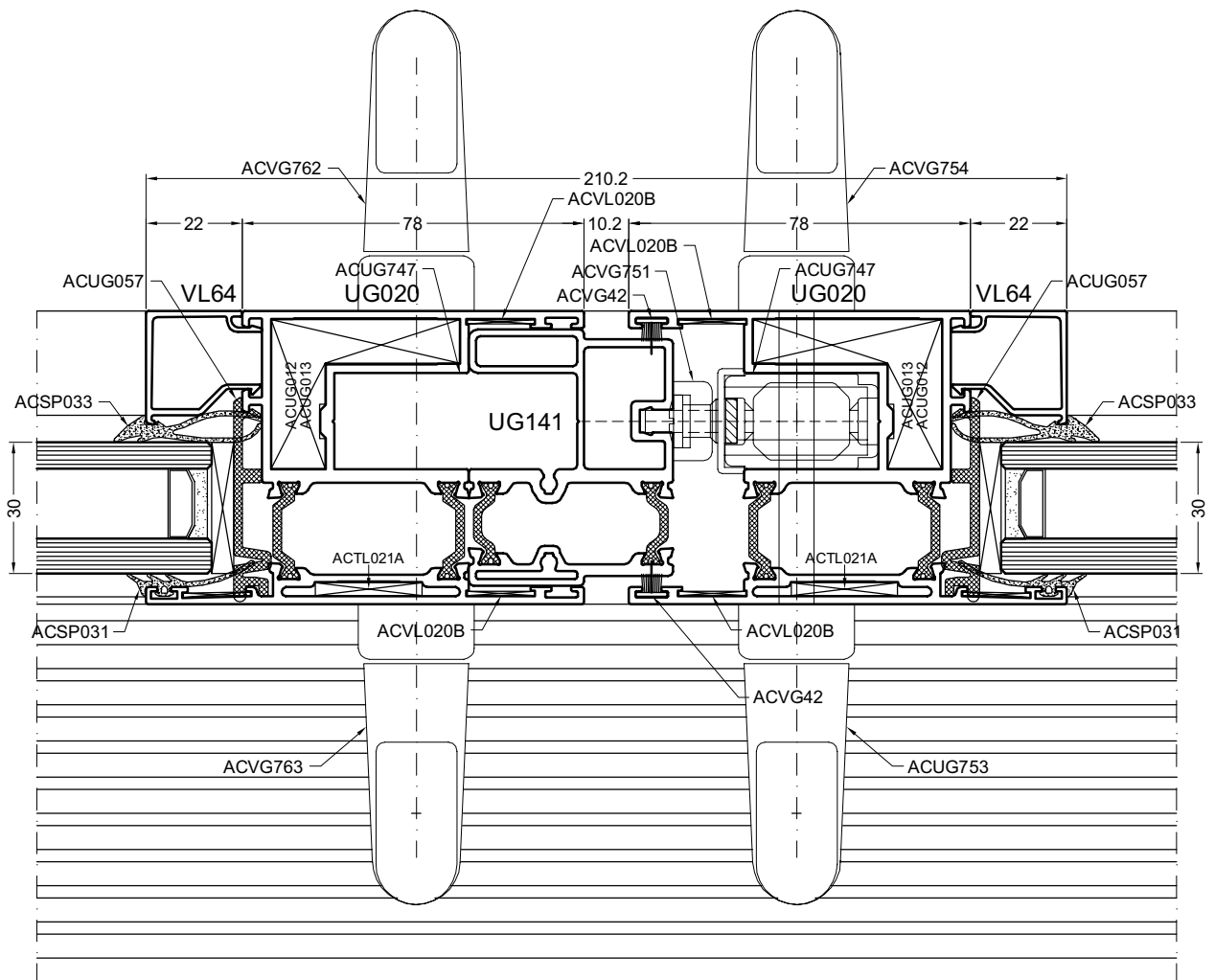

door22a



23A

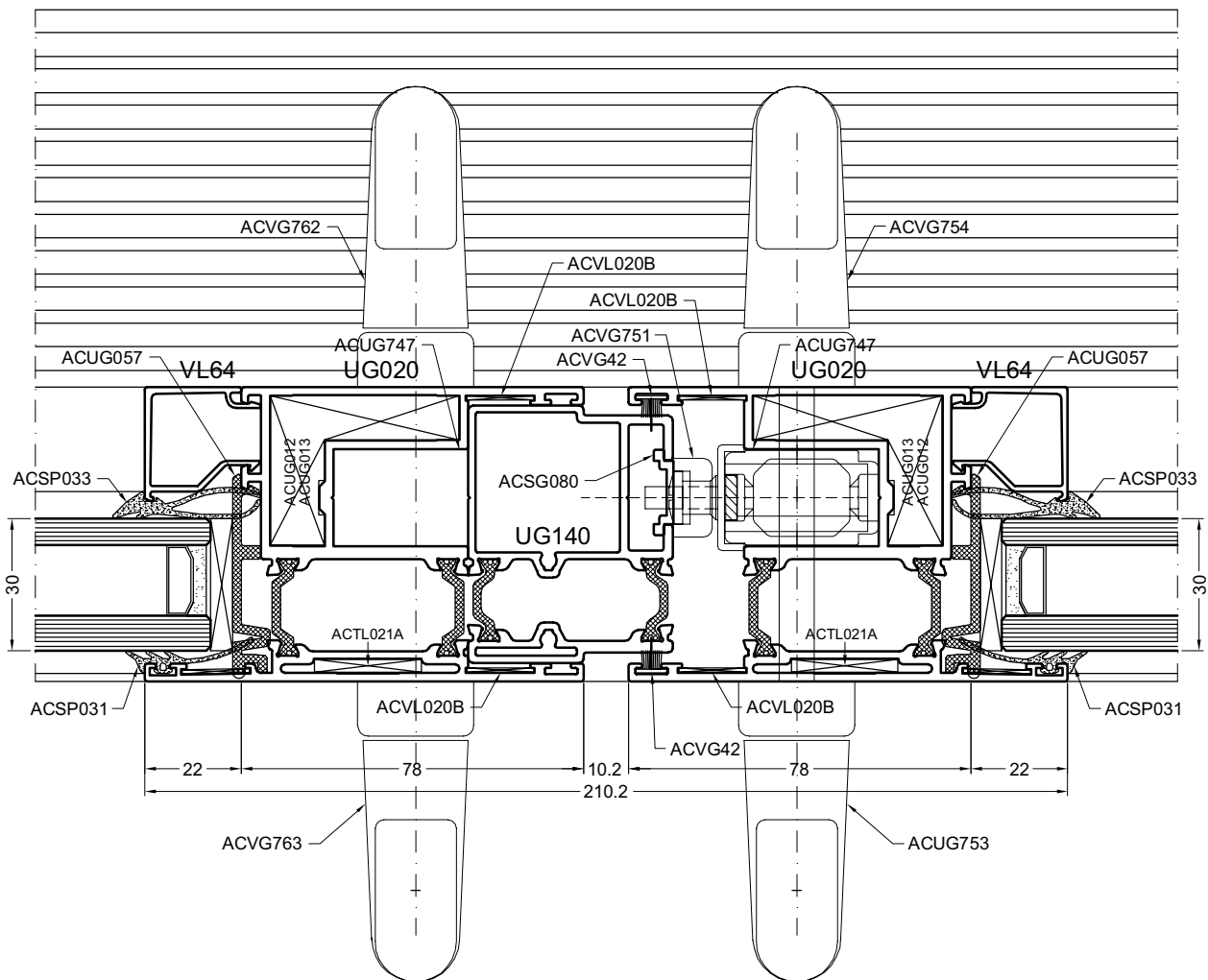

door23

23B

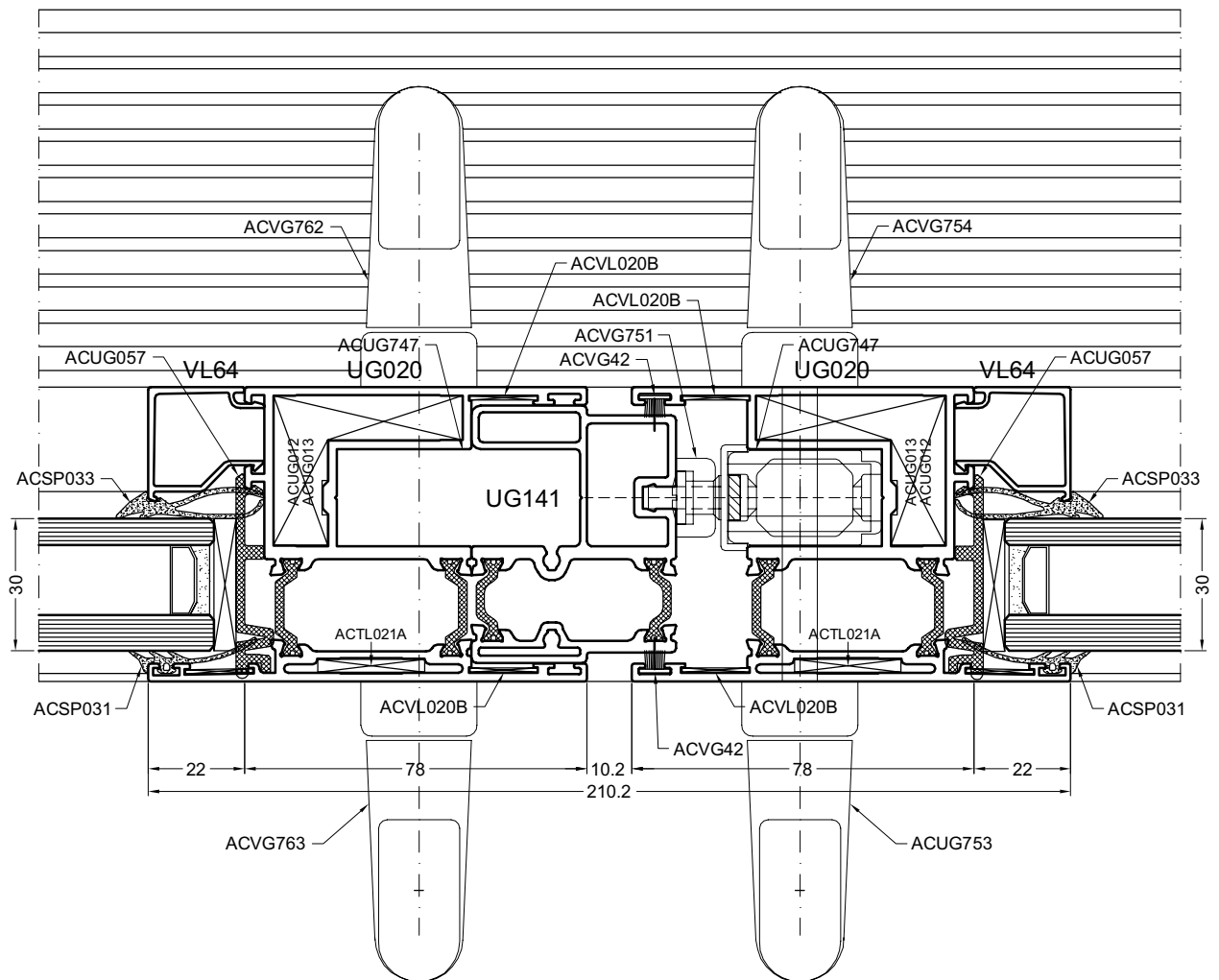

door23a

24A

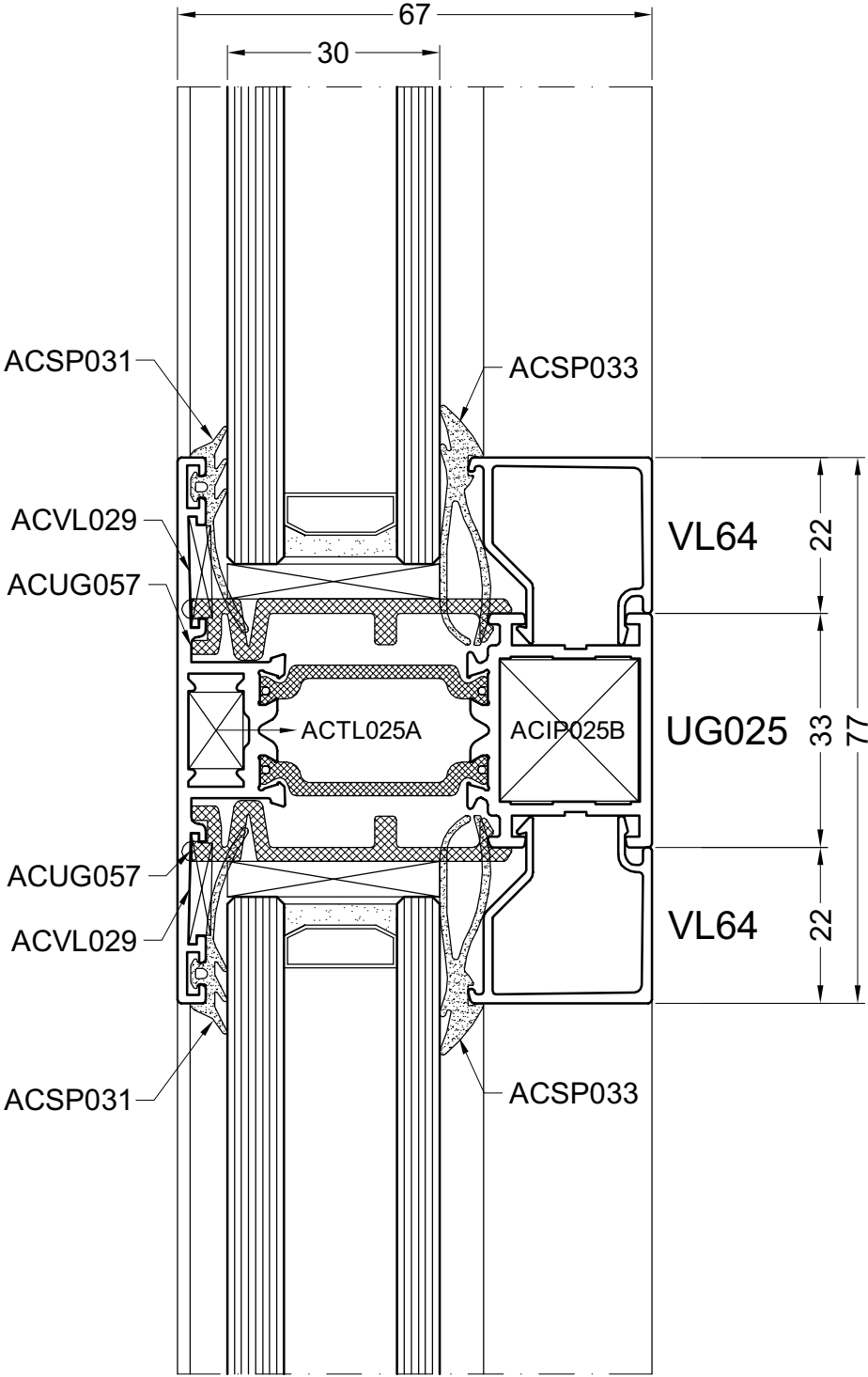

door24

24B

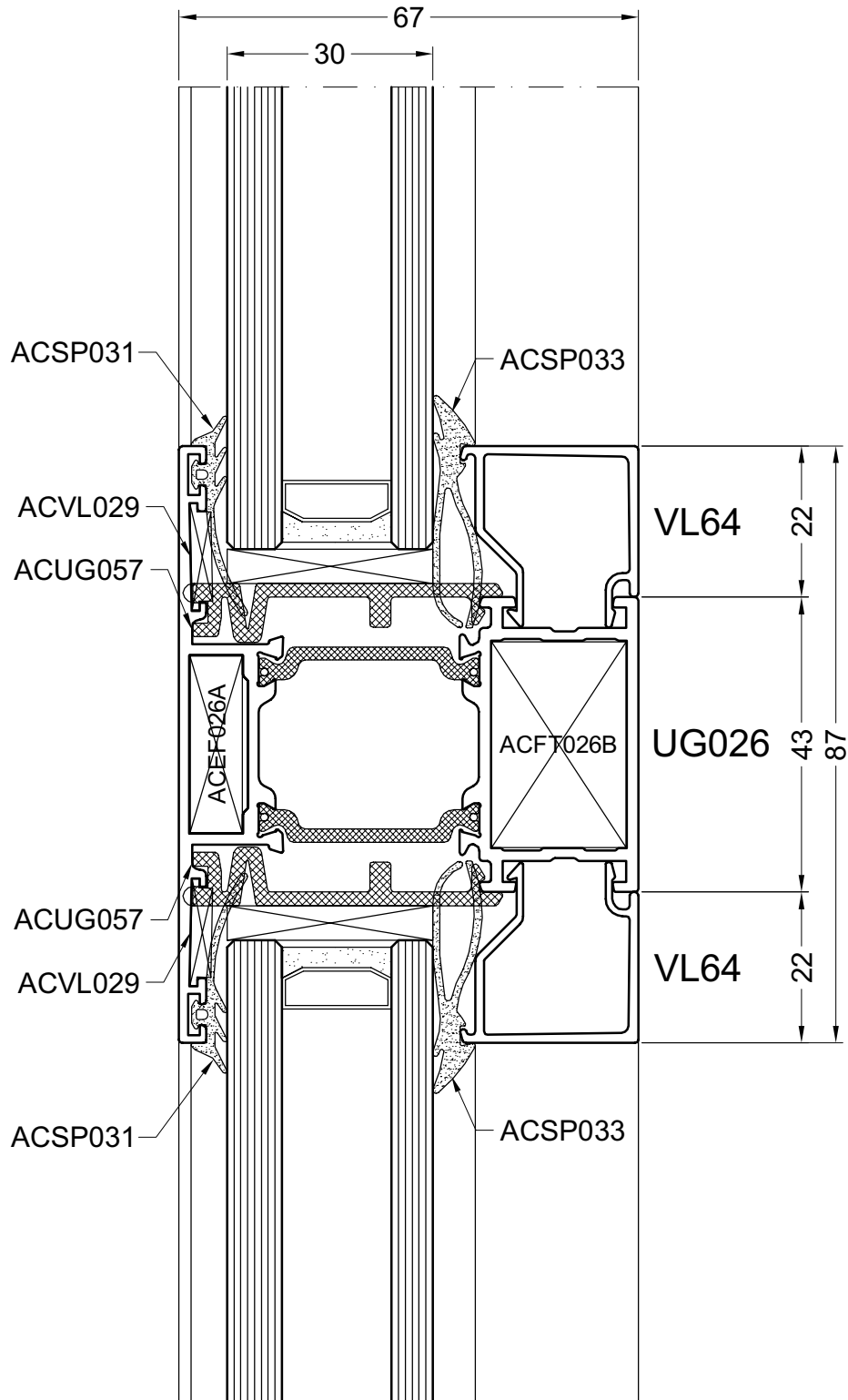

DOORSNEDE - COUPE - SCHNITT - SECTIONS

door24a

6/1/2010

BY ALIPLAST

24C

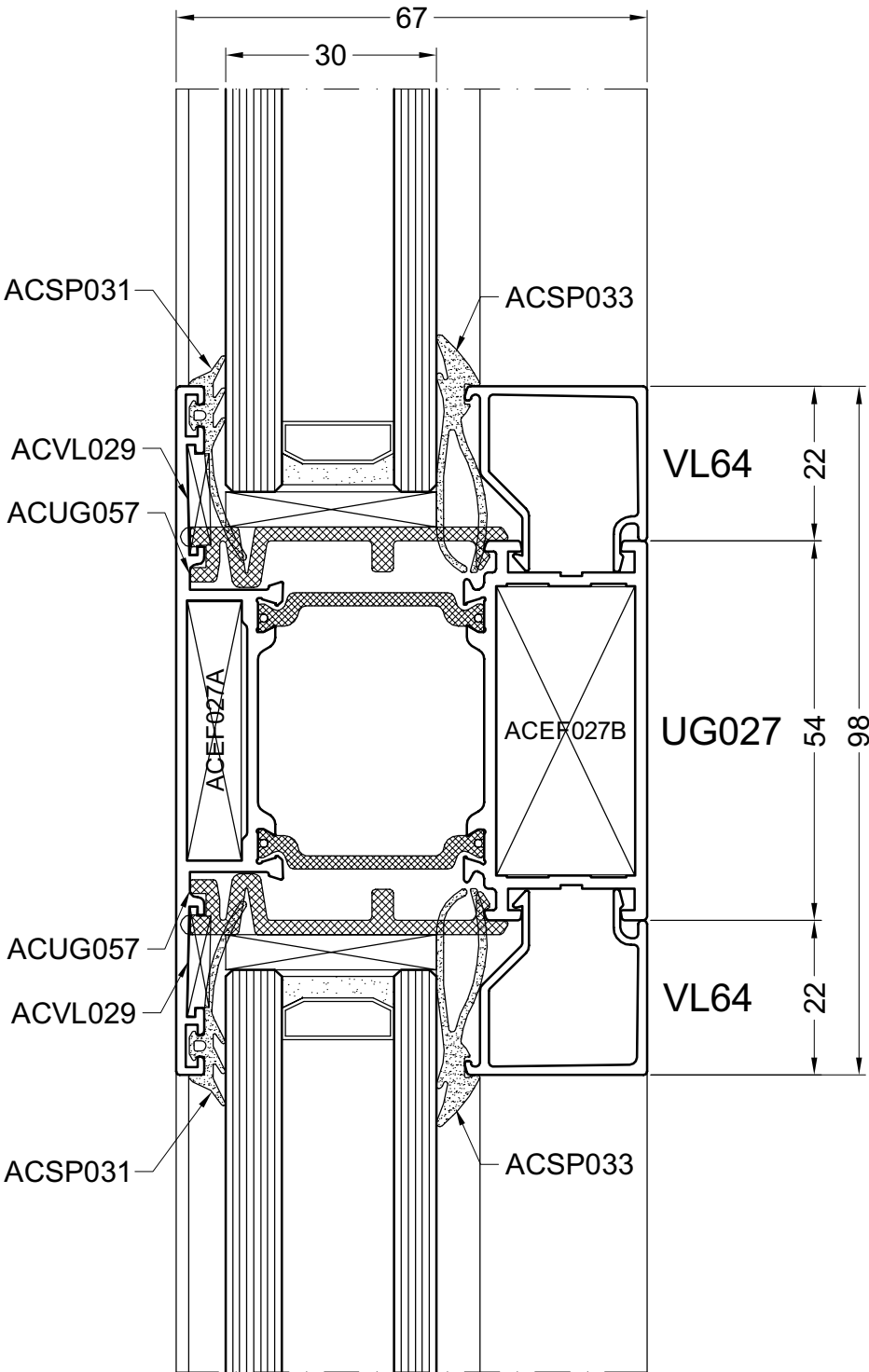

door24b

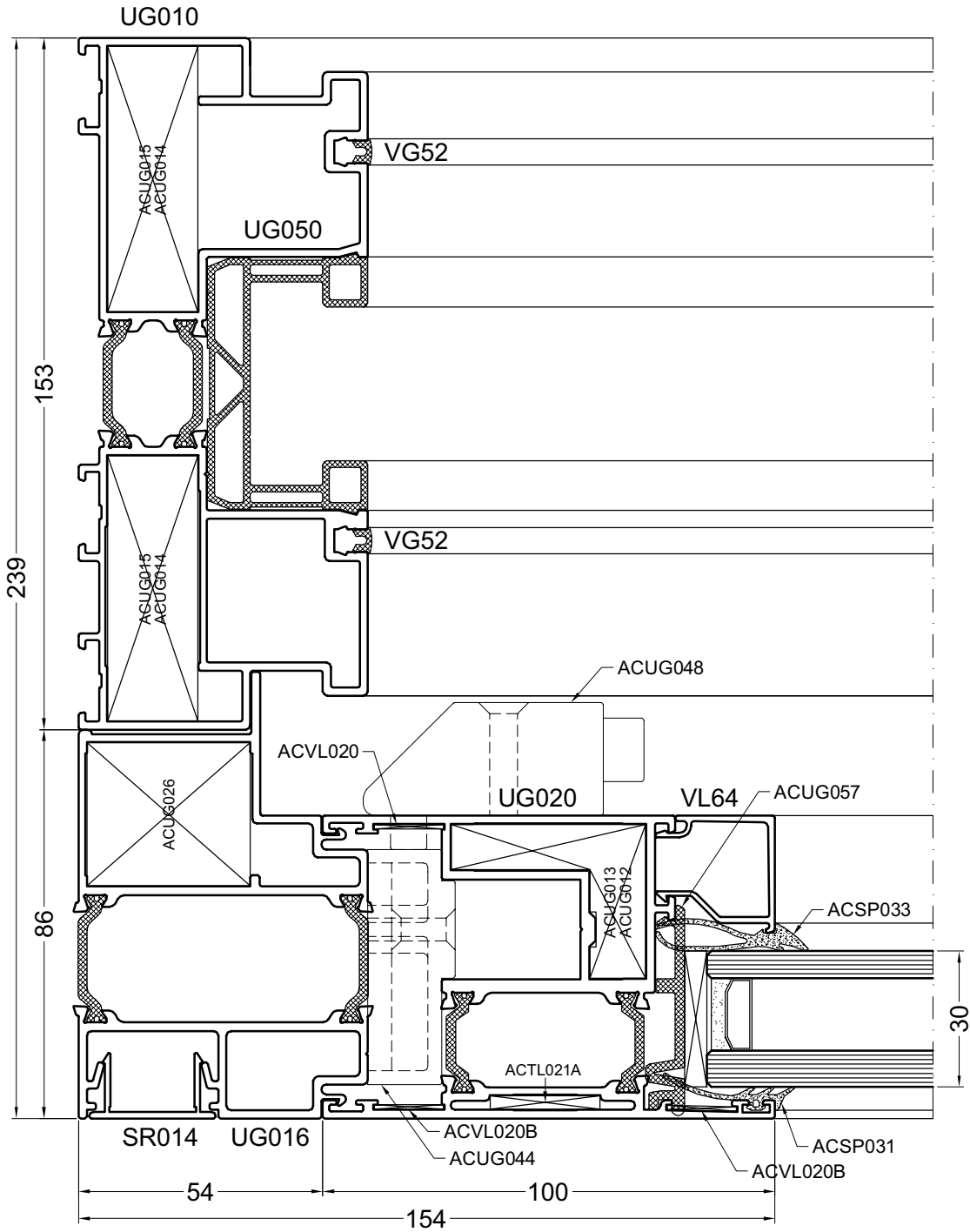

door25

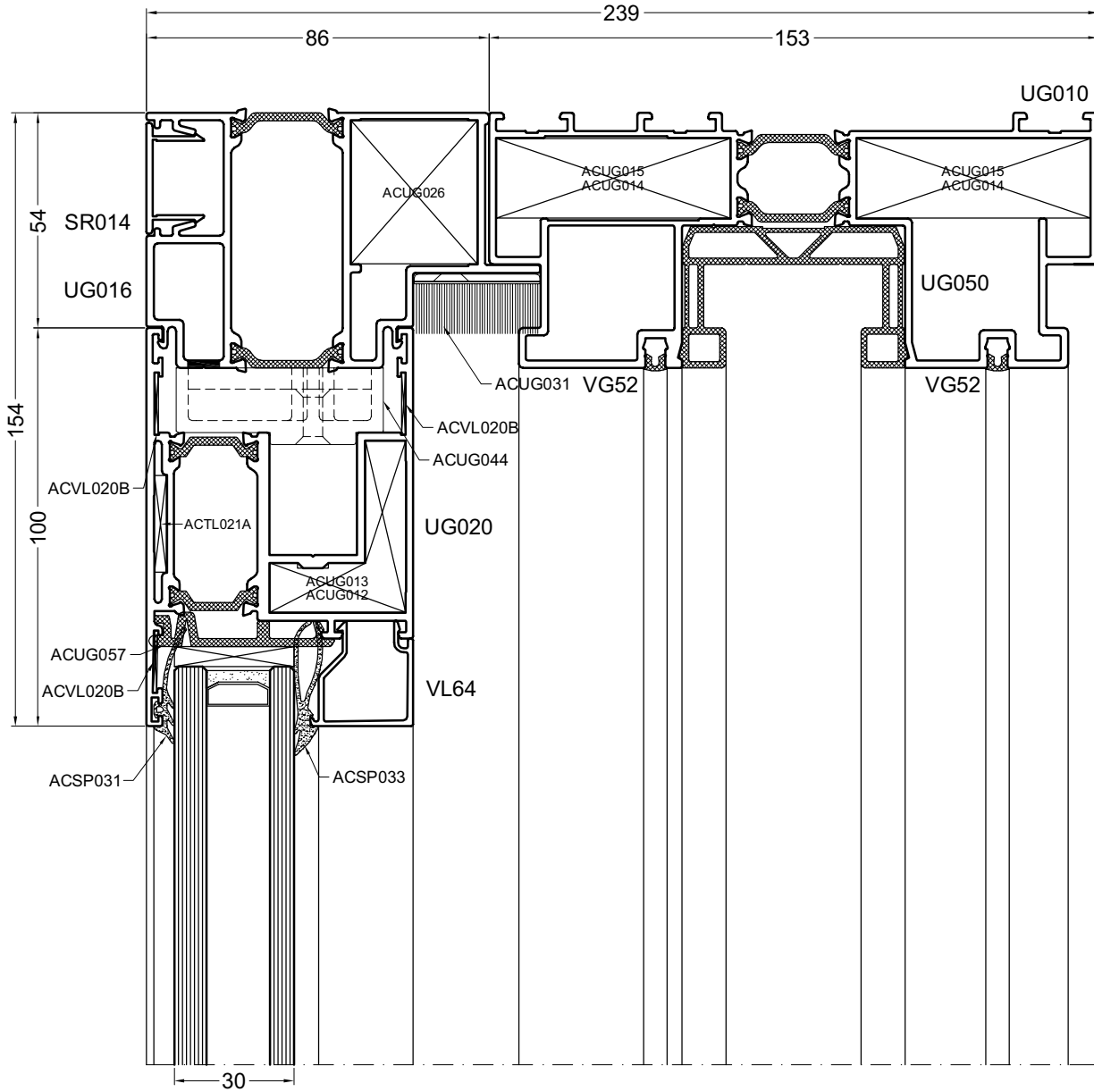

door26

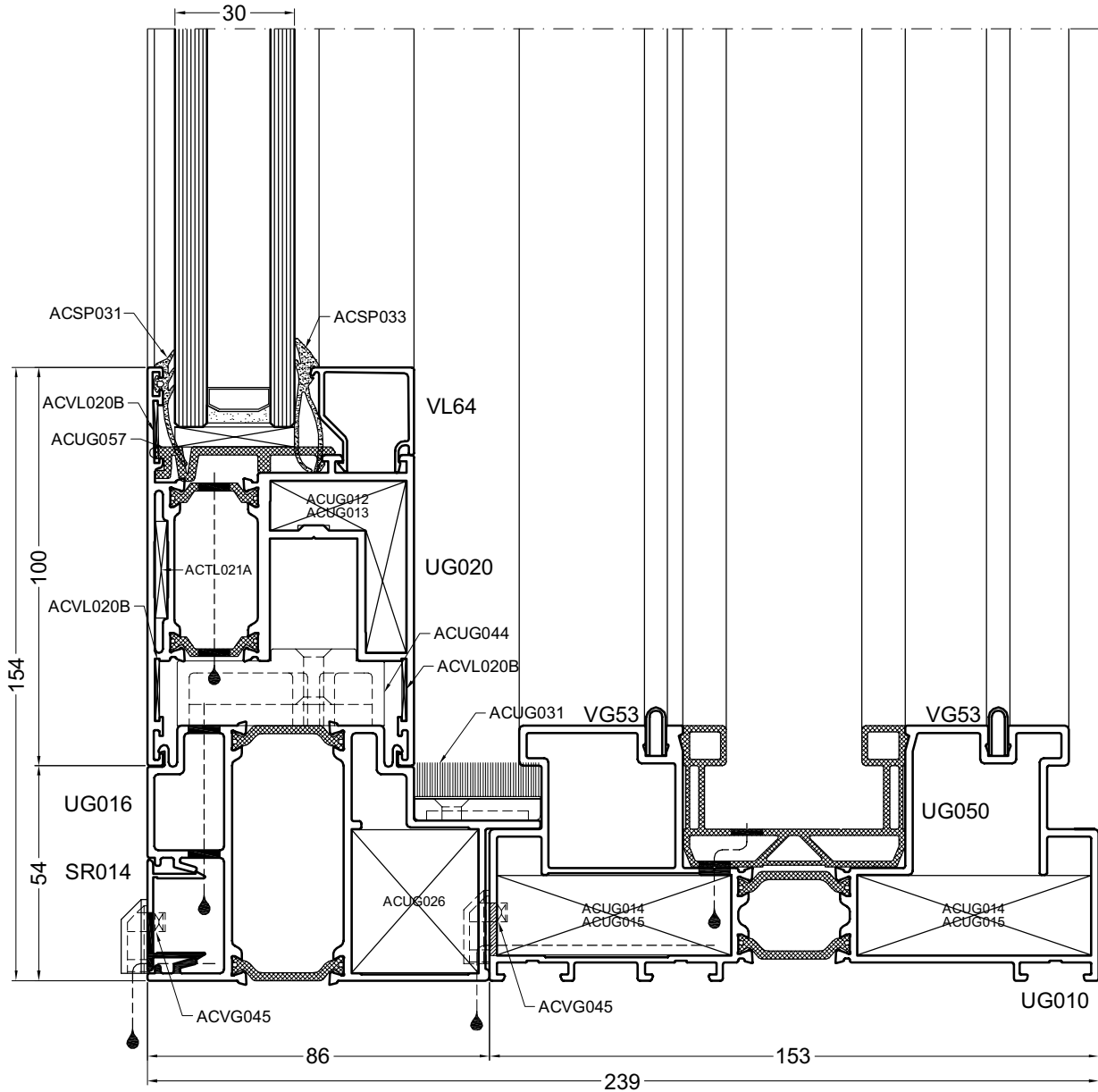

door27

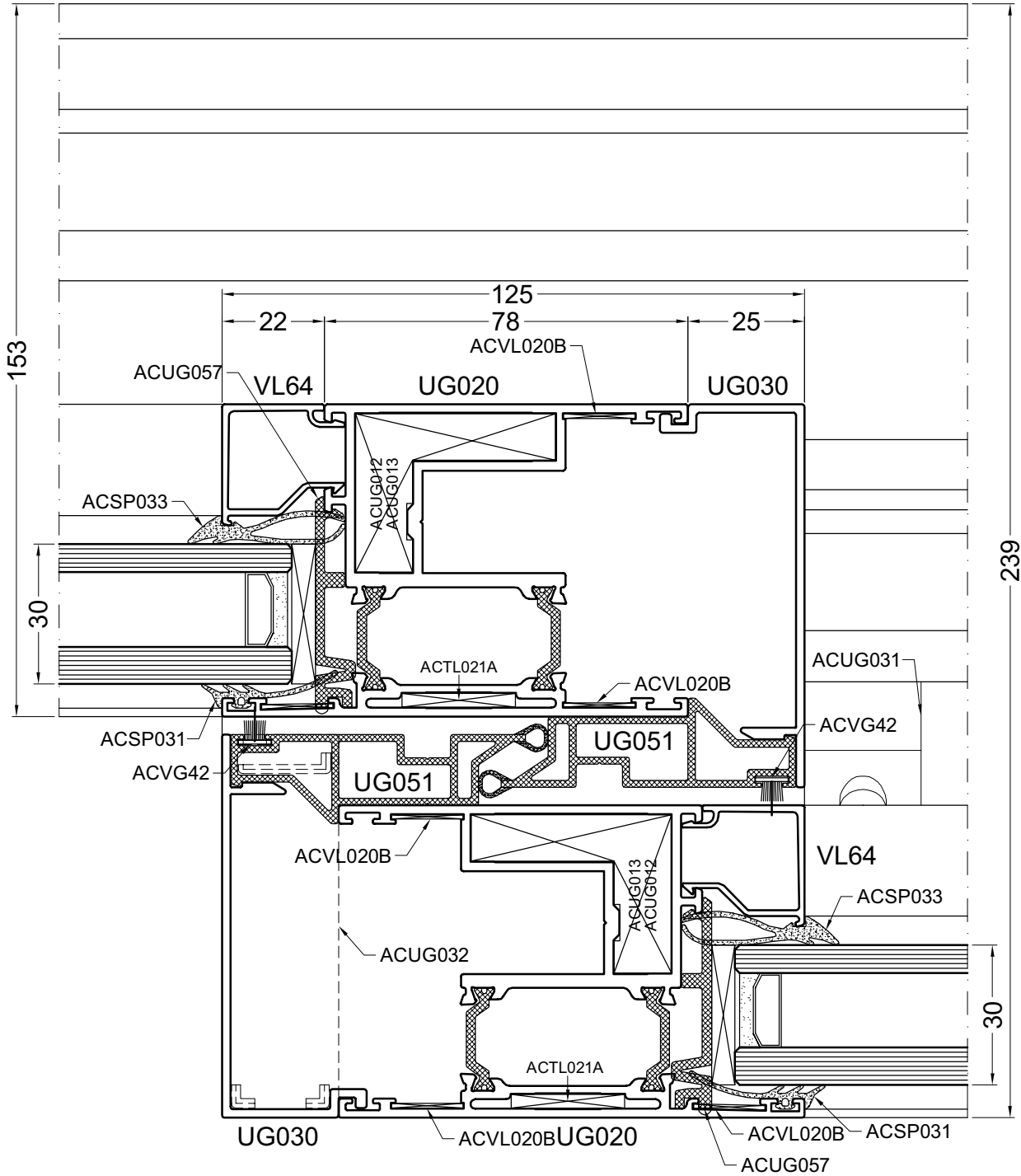

door28

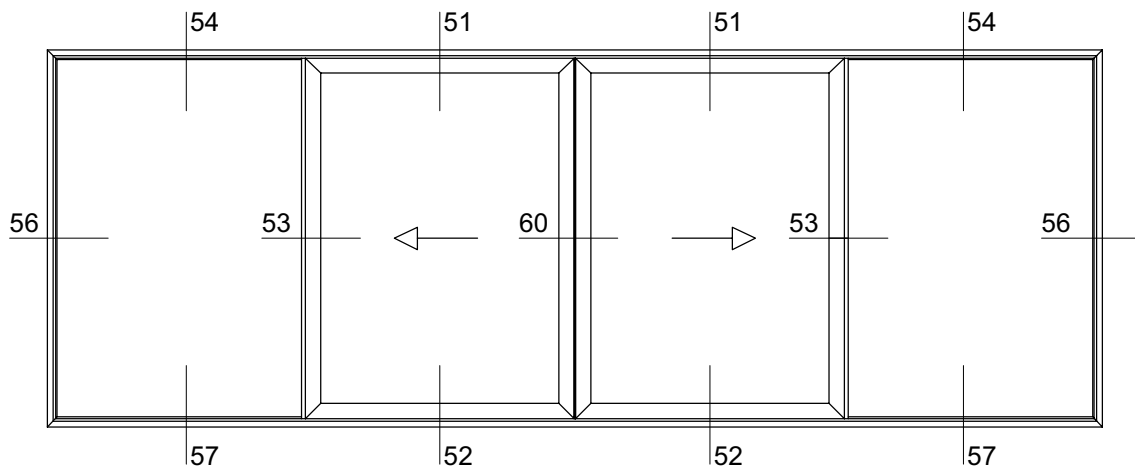
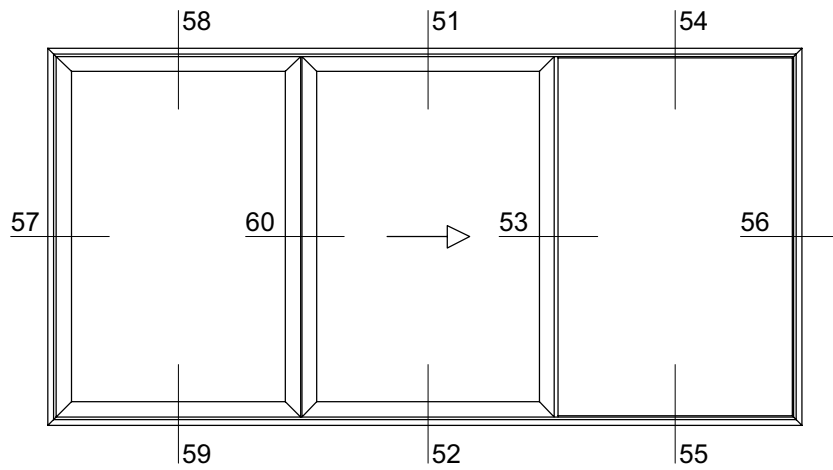
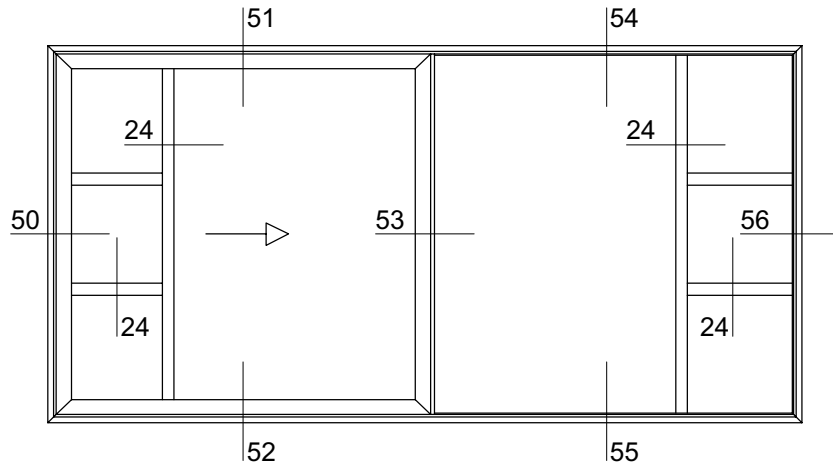

type05

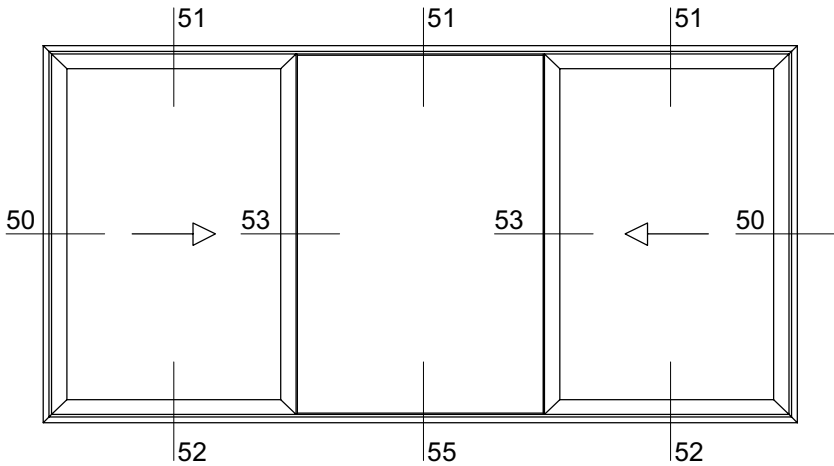

type06

50

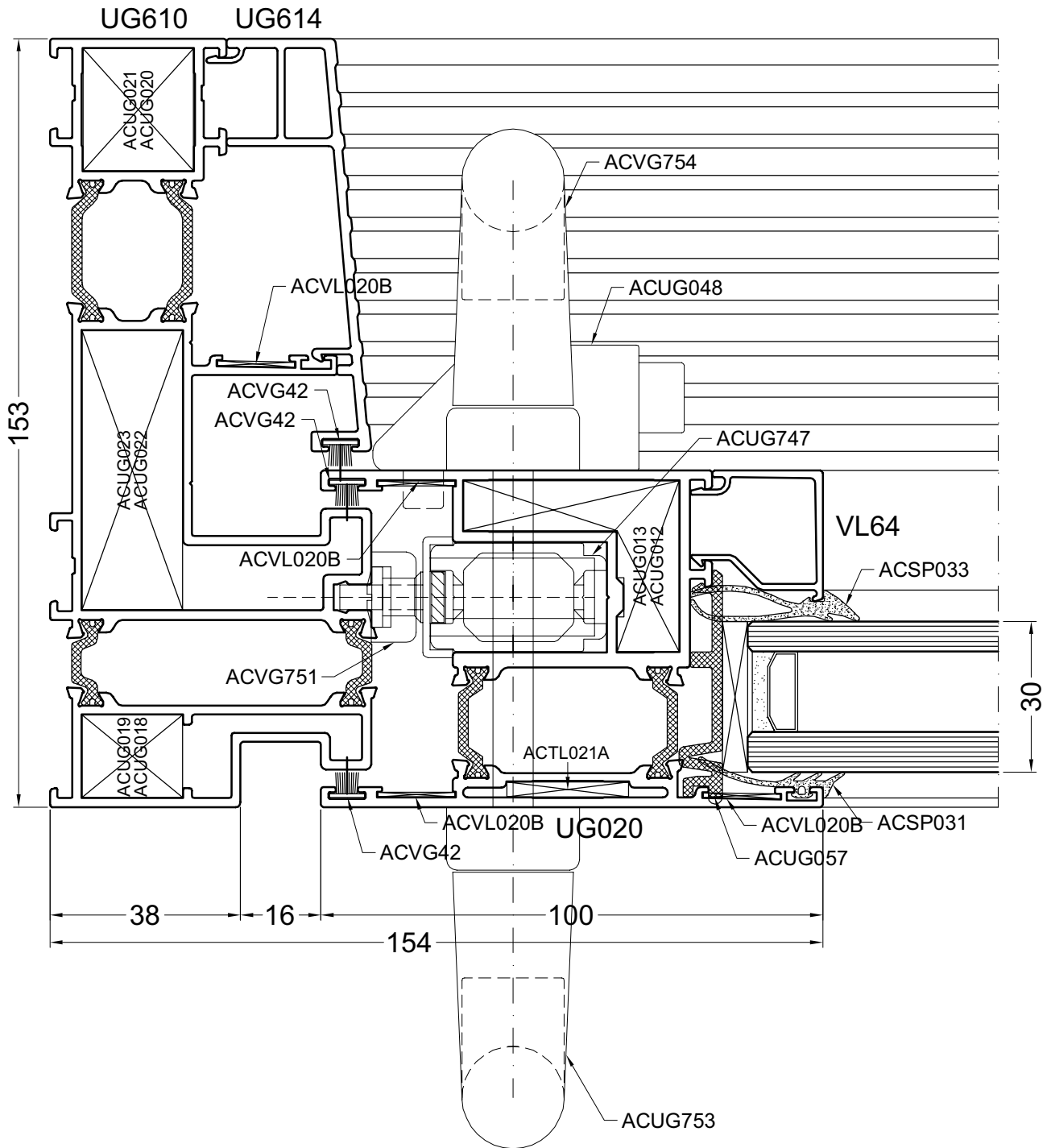

DOORSNEDE - COUPE - SCHNITT - SECTIONS

door50

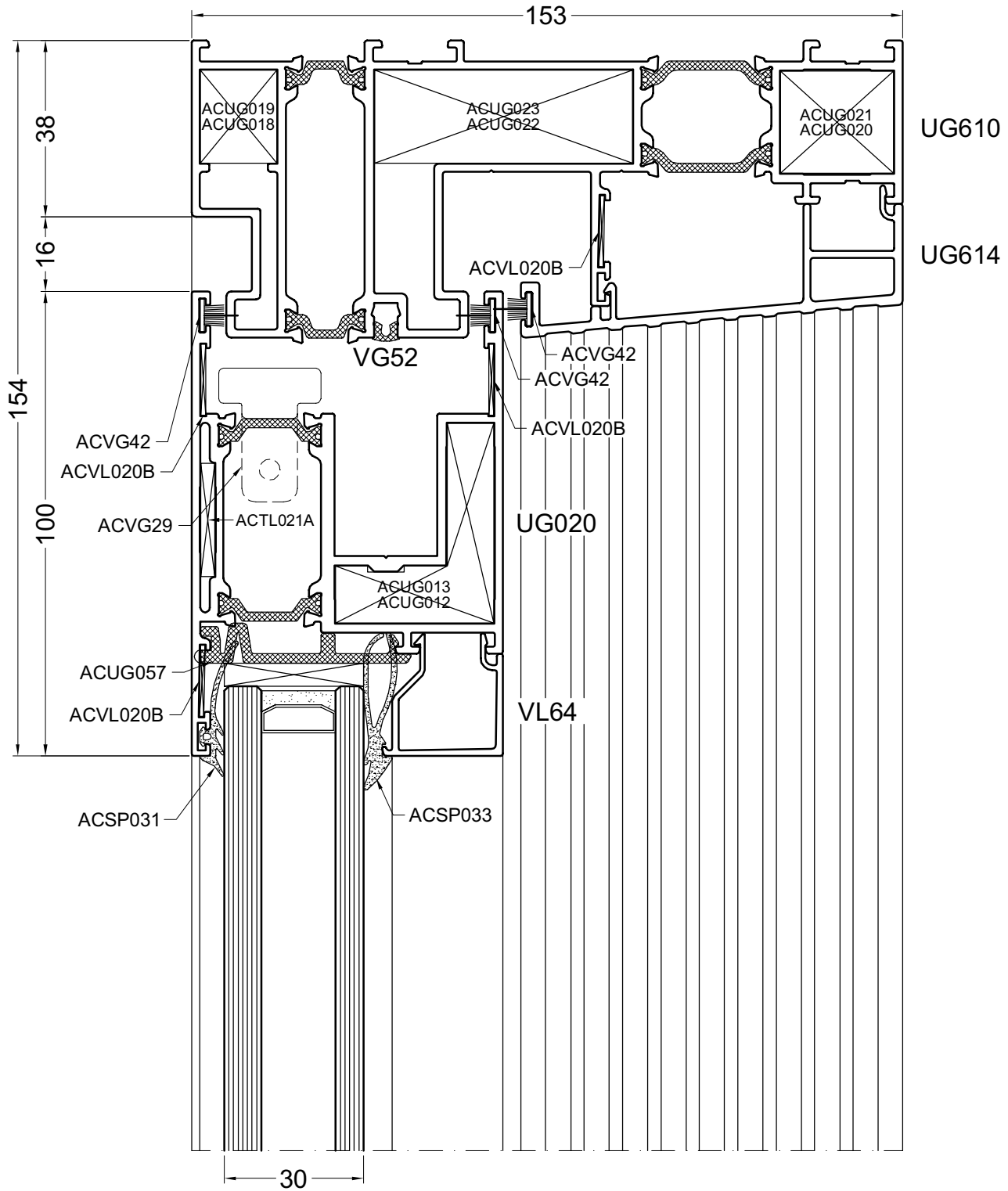

door51

52

DOORSNEDE - COUPE - SCHNITT - SECTIONS

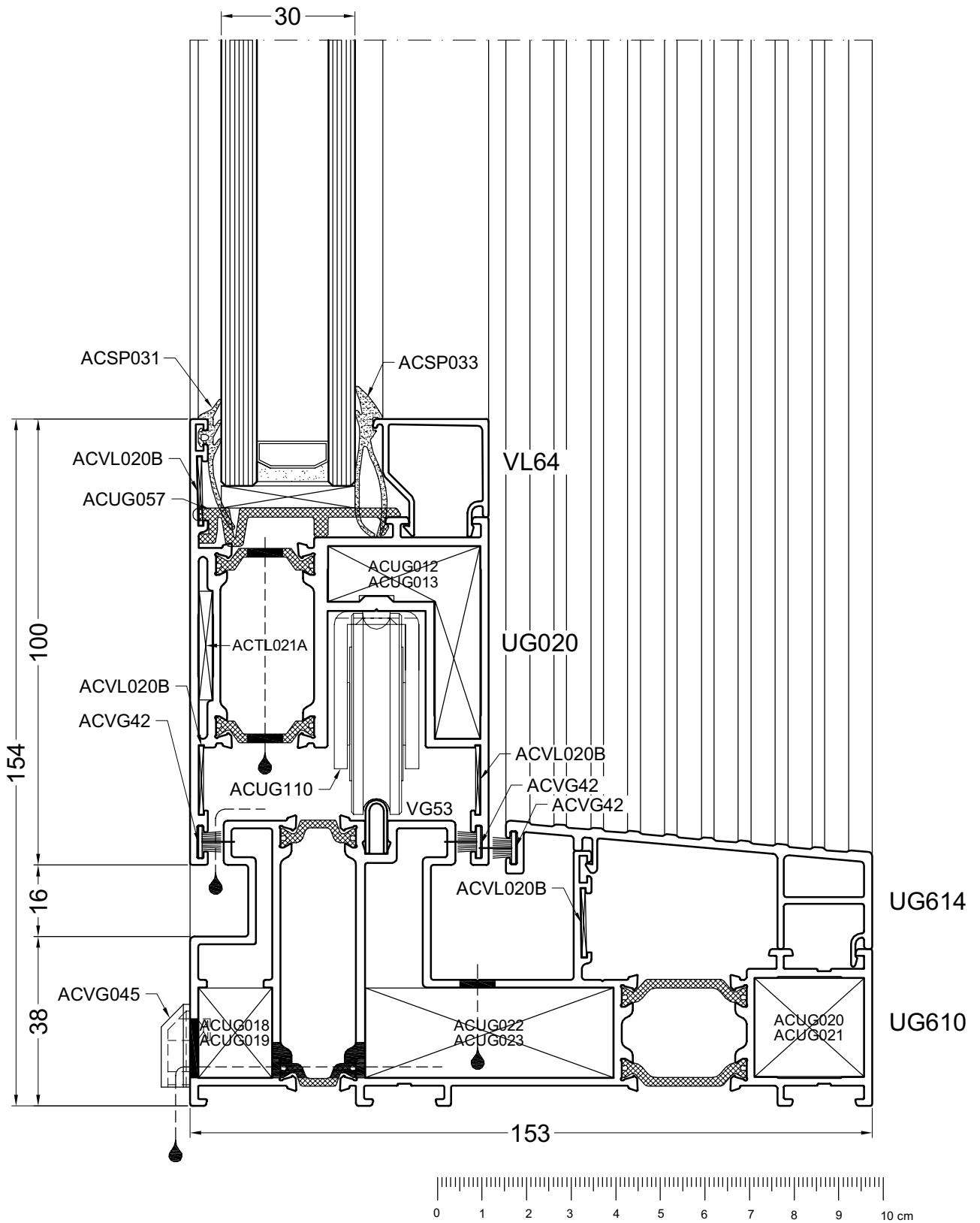

door52

53A

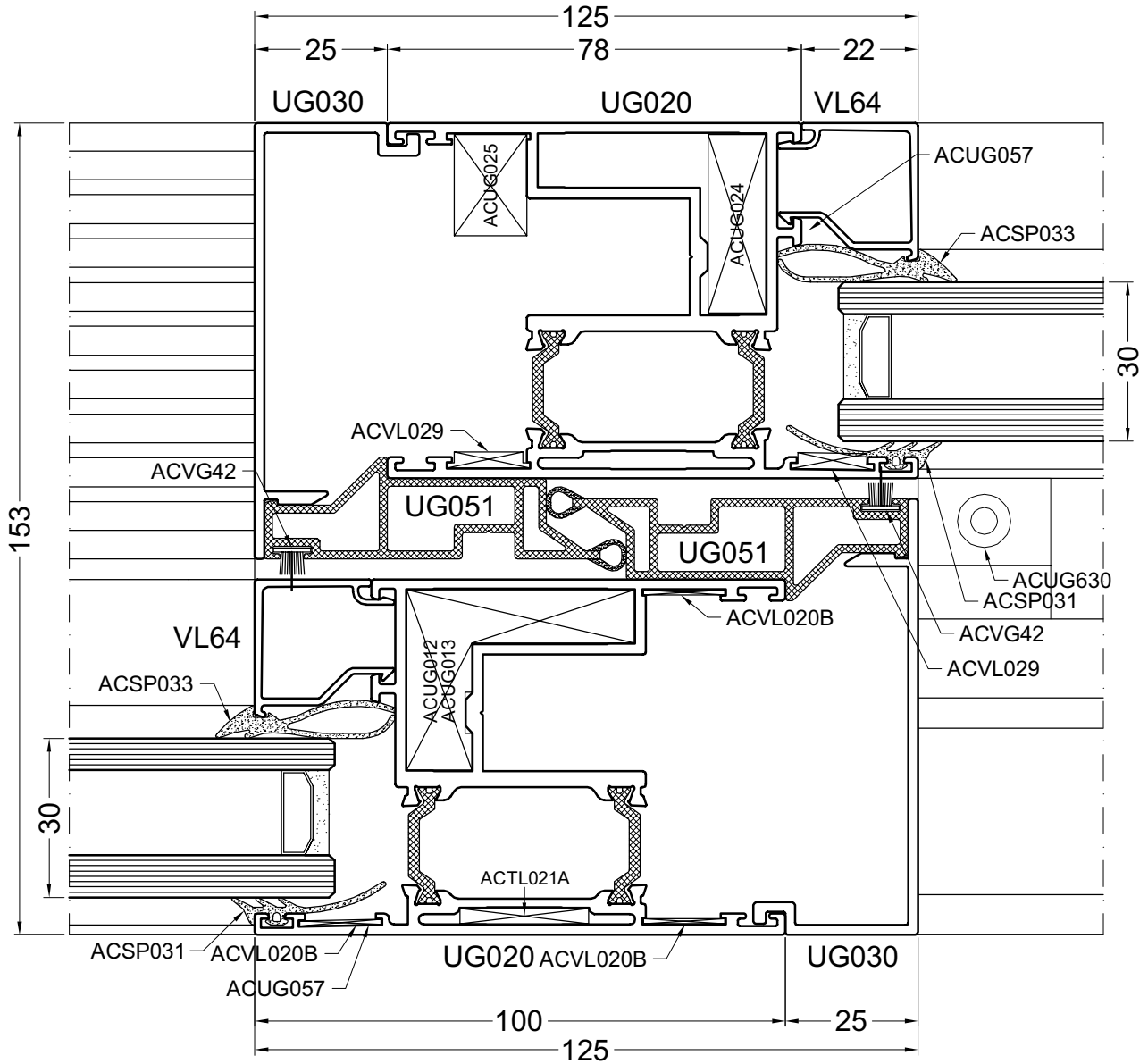

door53

53B

DOORSNEDE - COUPE - SCHNITT - SECTIONS

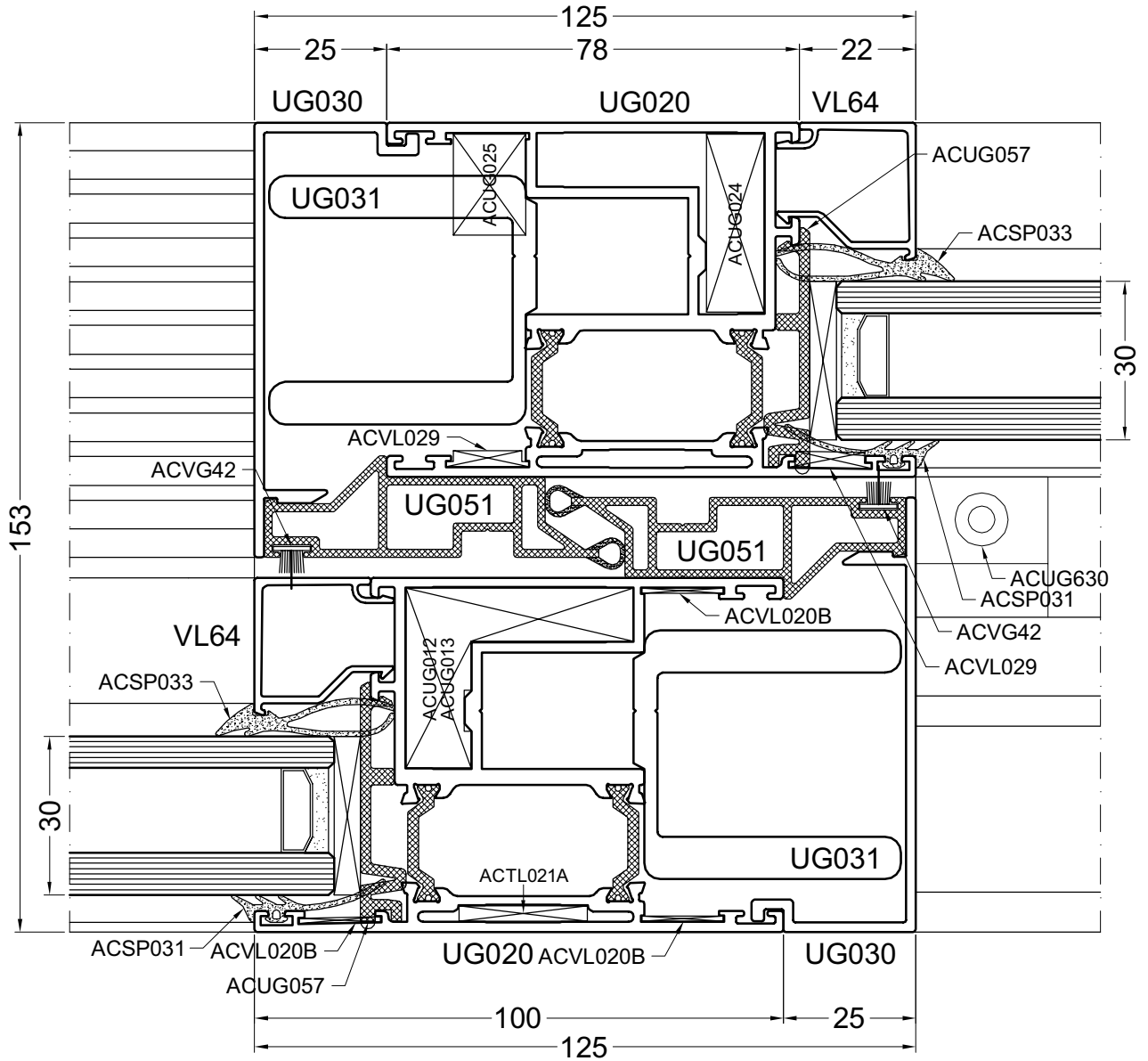

door53a

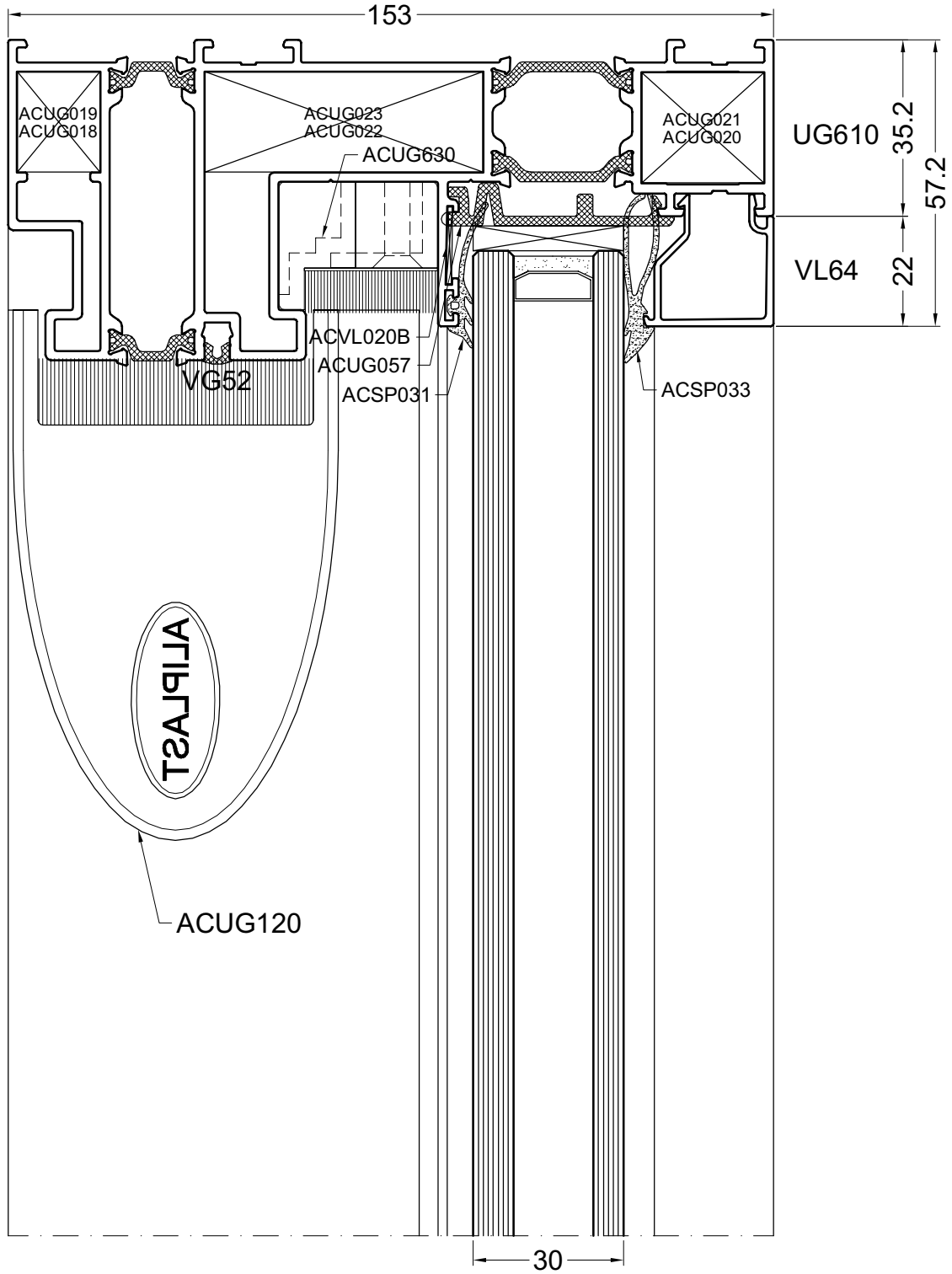

door54

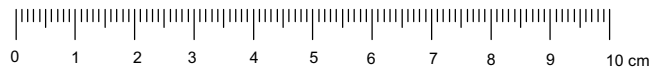

55

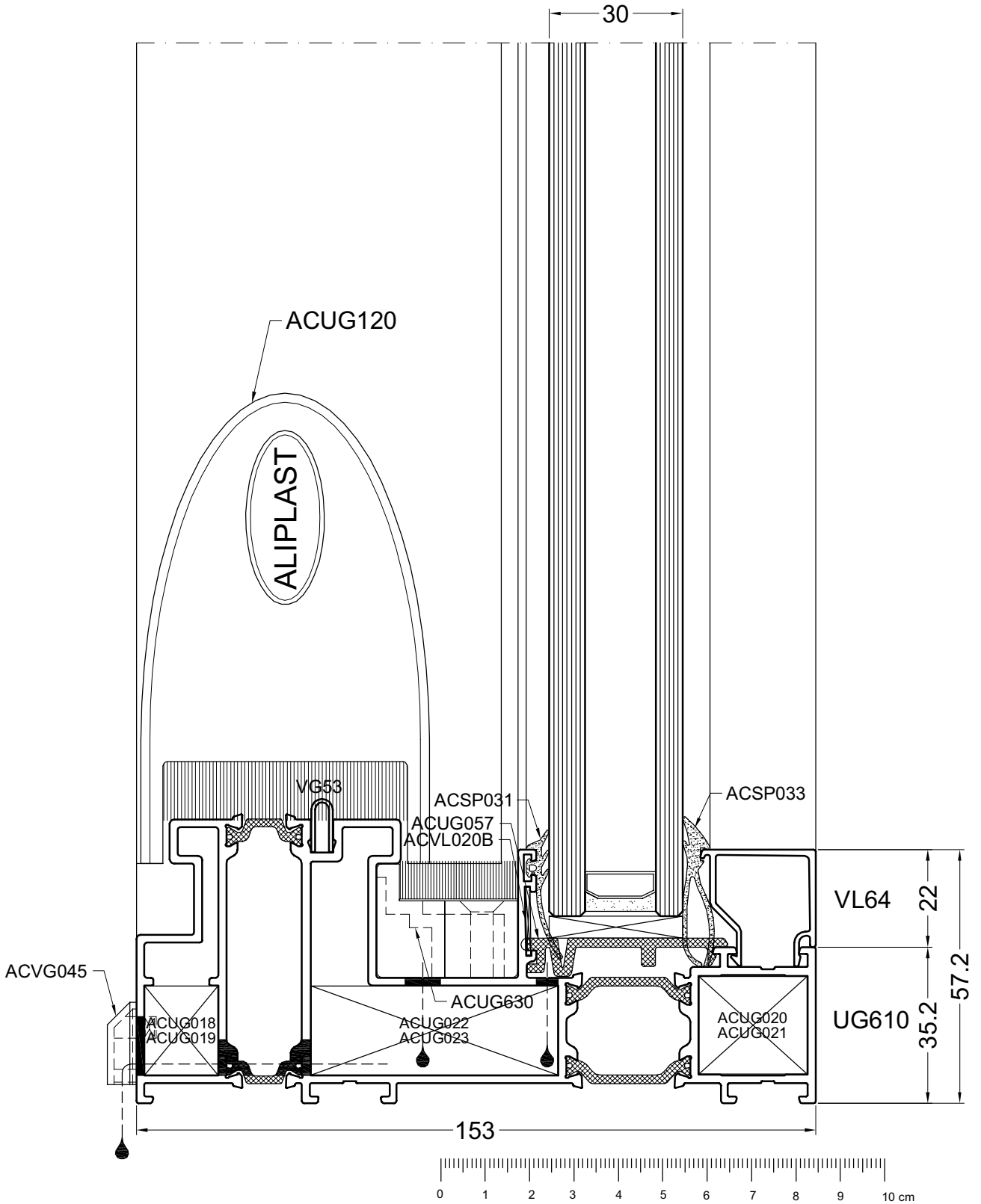

DOORSNEDE - COUPE - SCHNITT - SECTIONS

door55

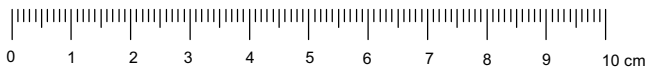
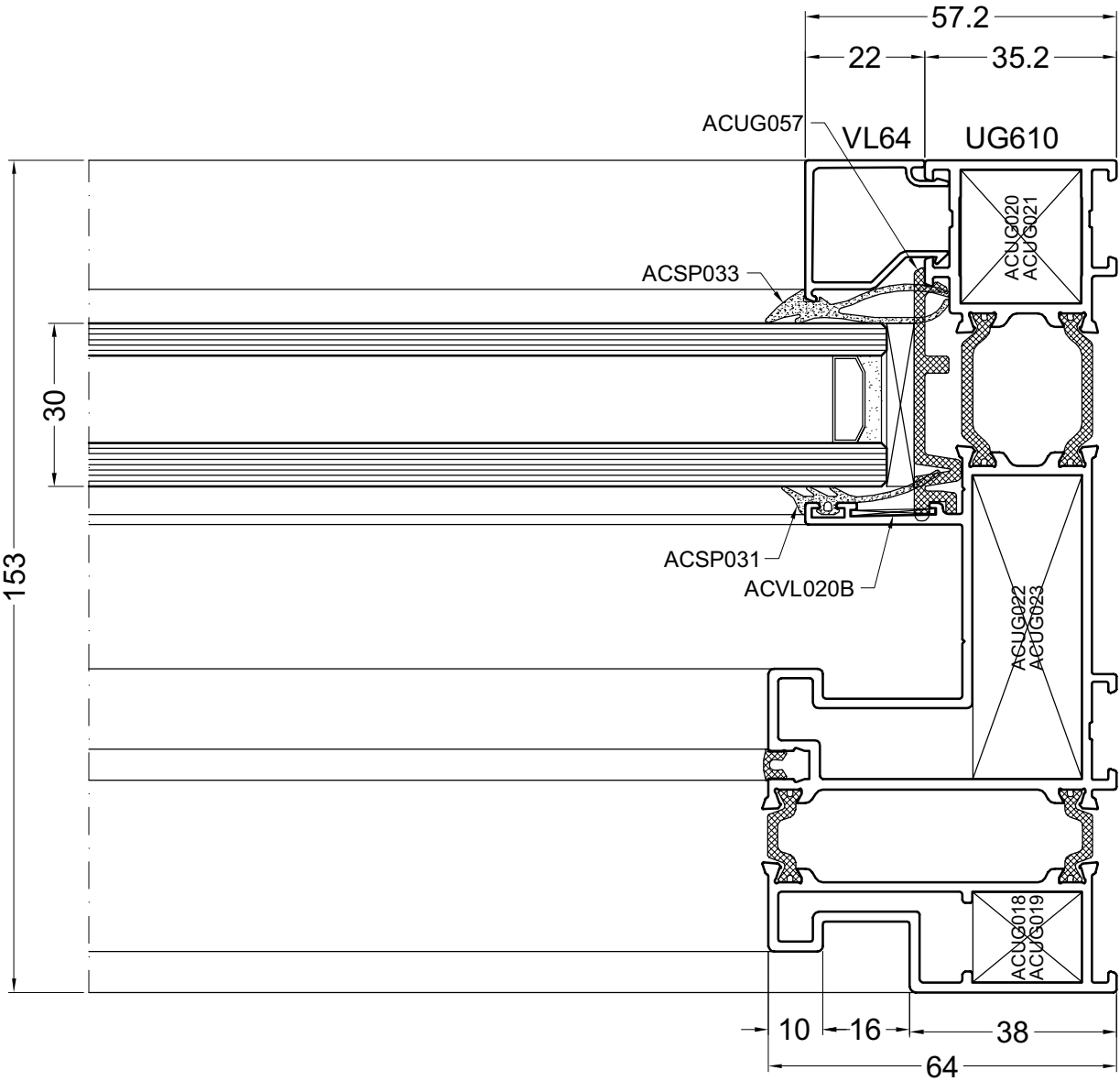

door56

57

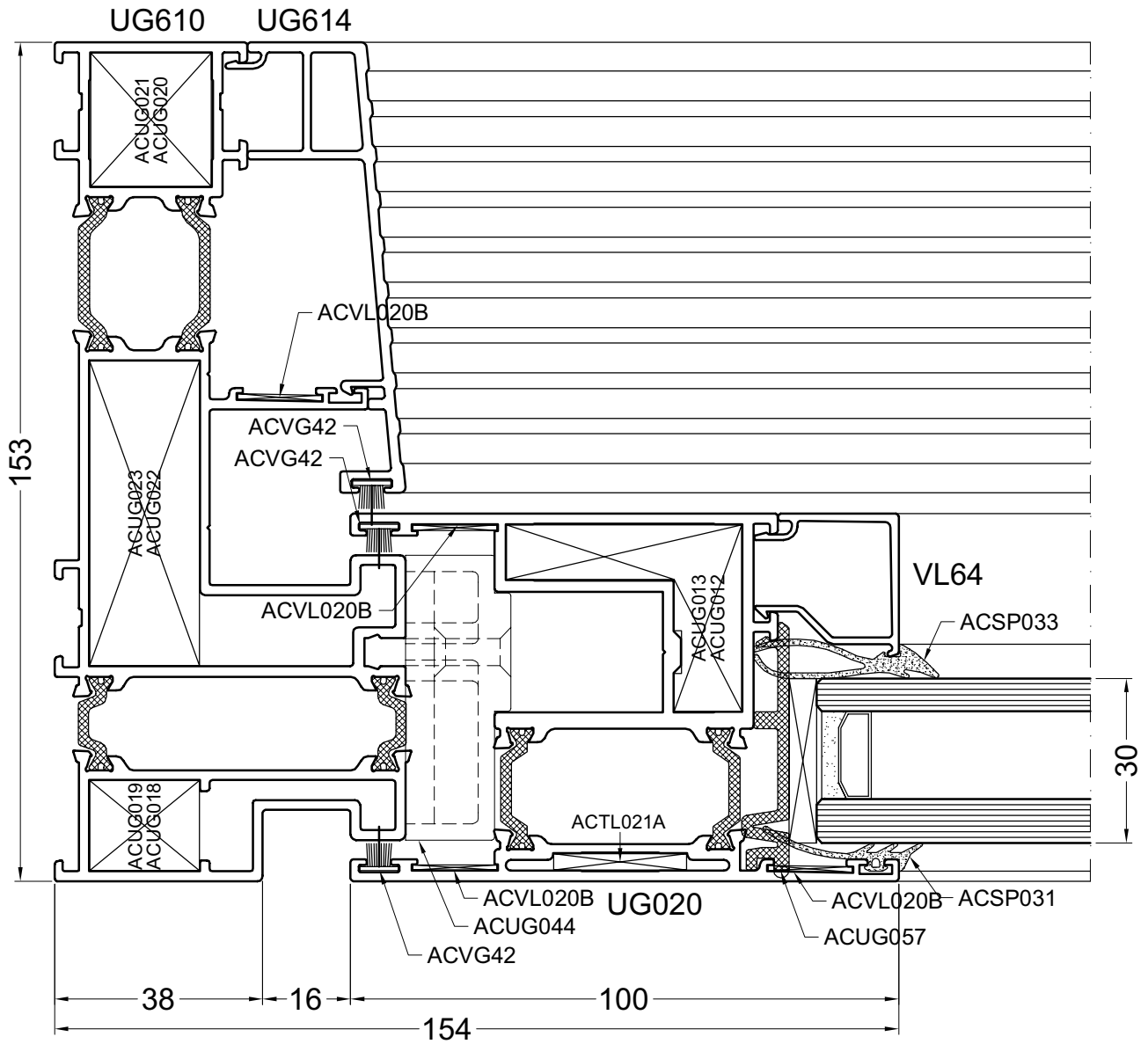

DOORSNEDE - COUPE - SCHNITT - SECTIONS

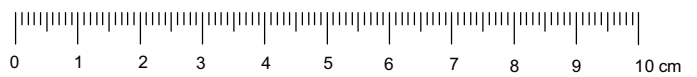

door57

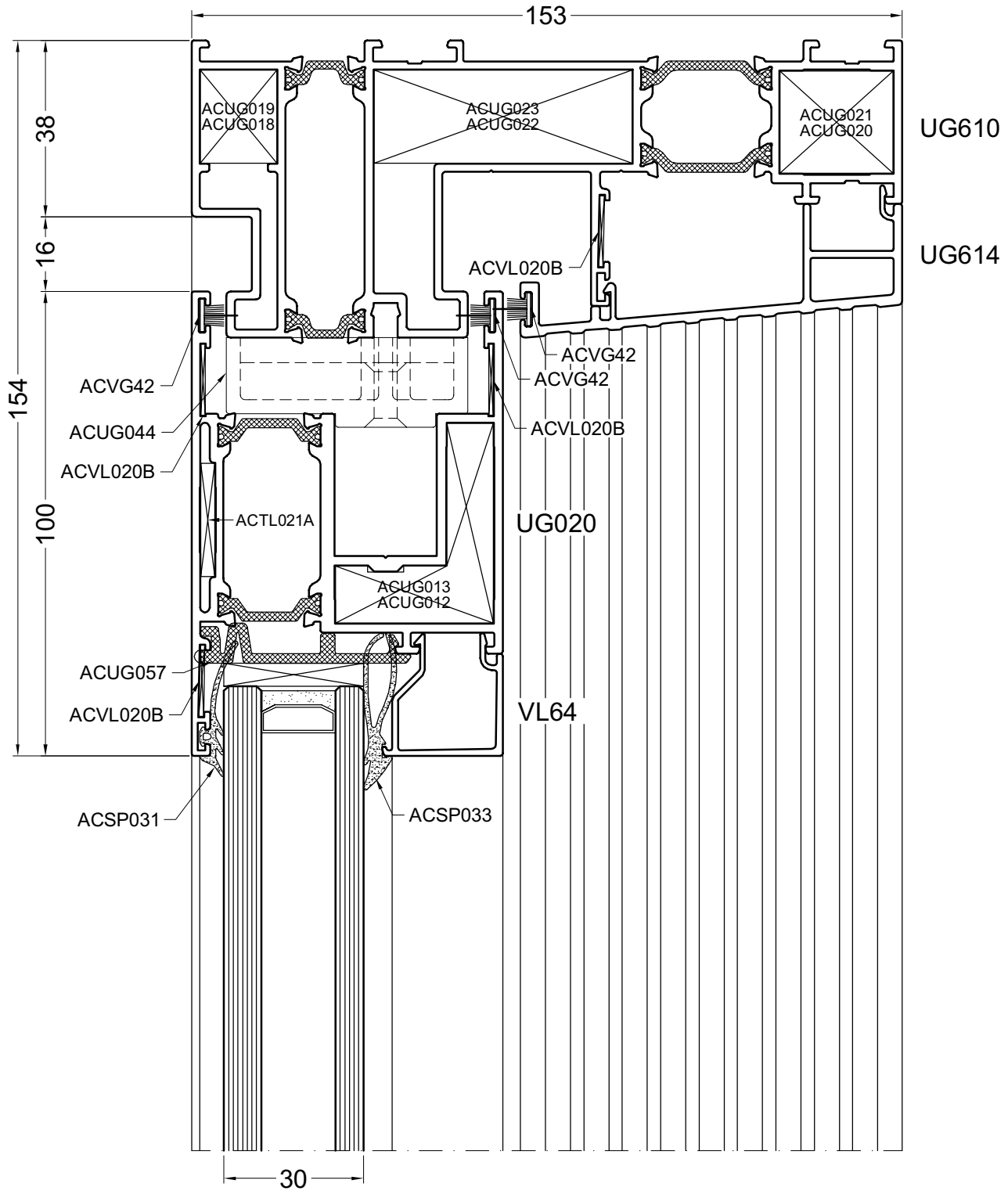

door58



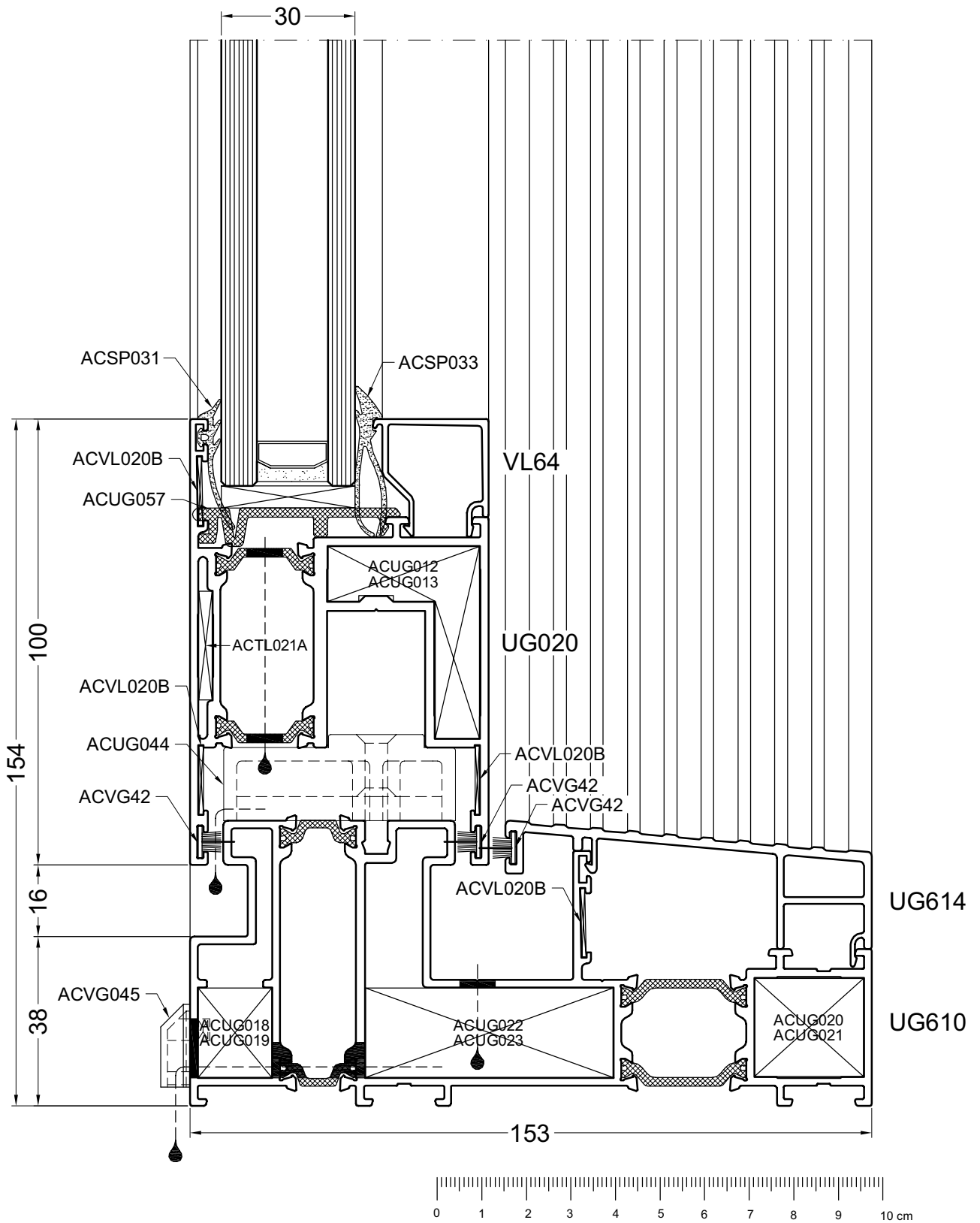

DOORSNEDE - COUPE - SCHNITT - SECTIONS

door59

60A

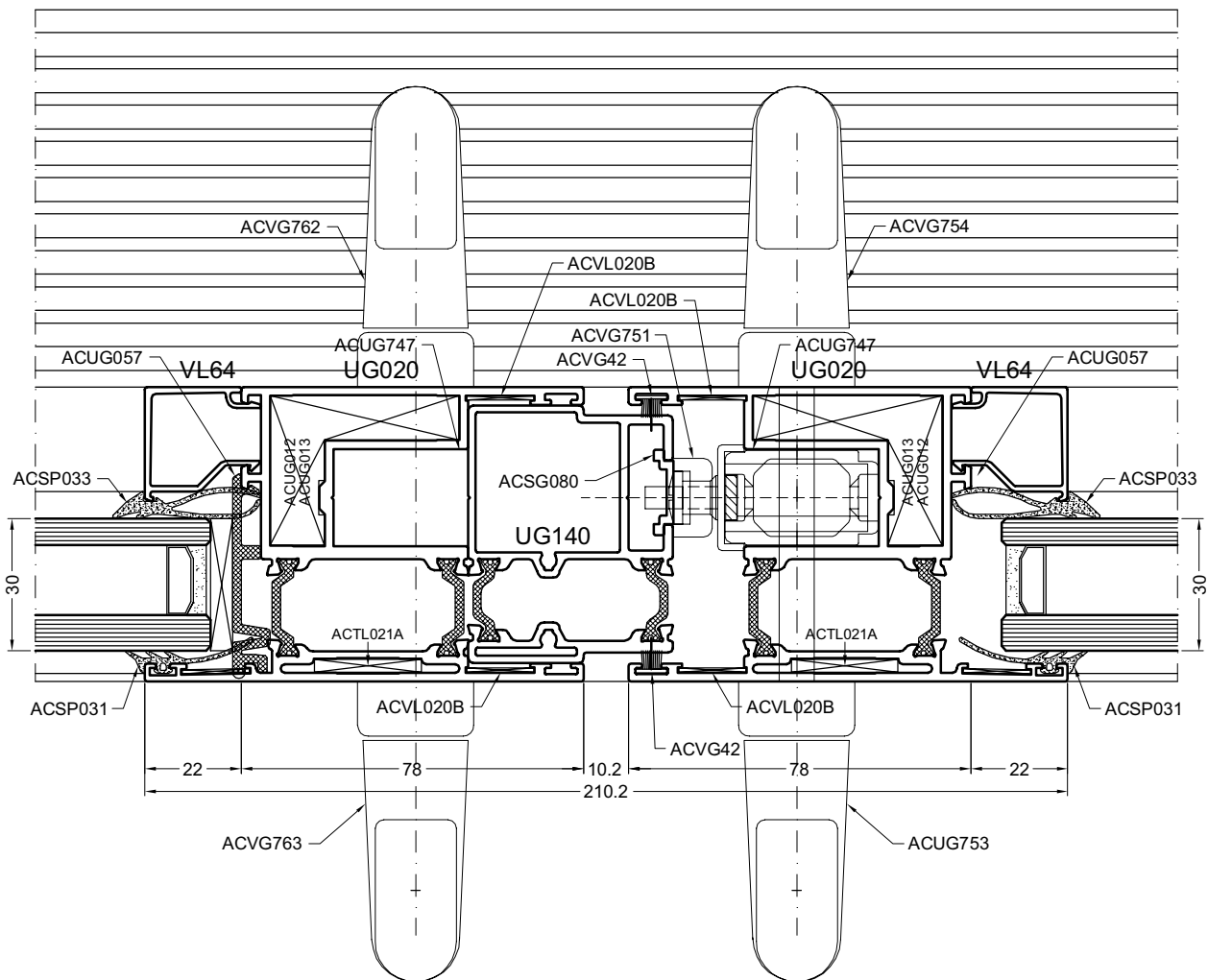

door60

60B

DOORSNEDE - COUPE - SCHNITT - SECTIONS

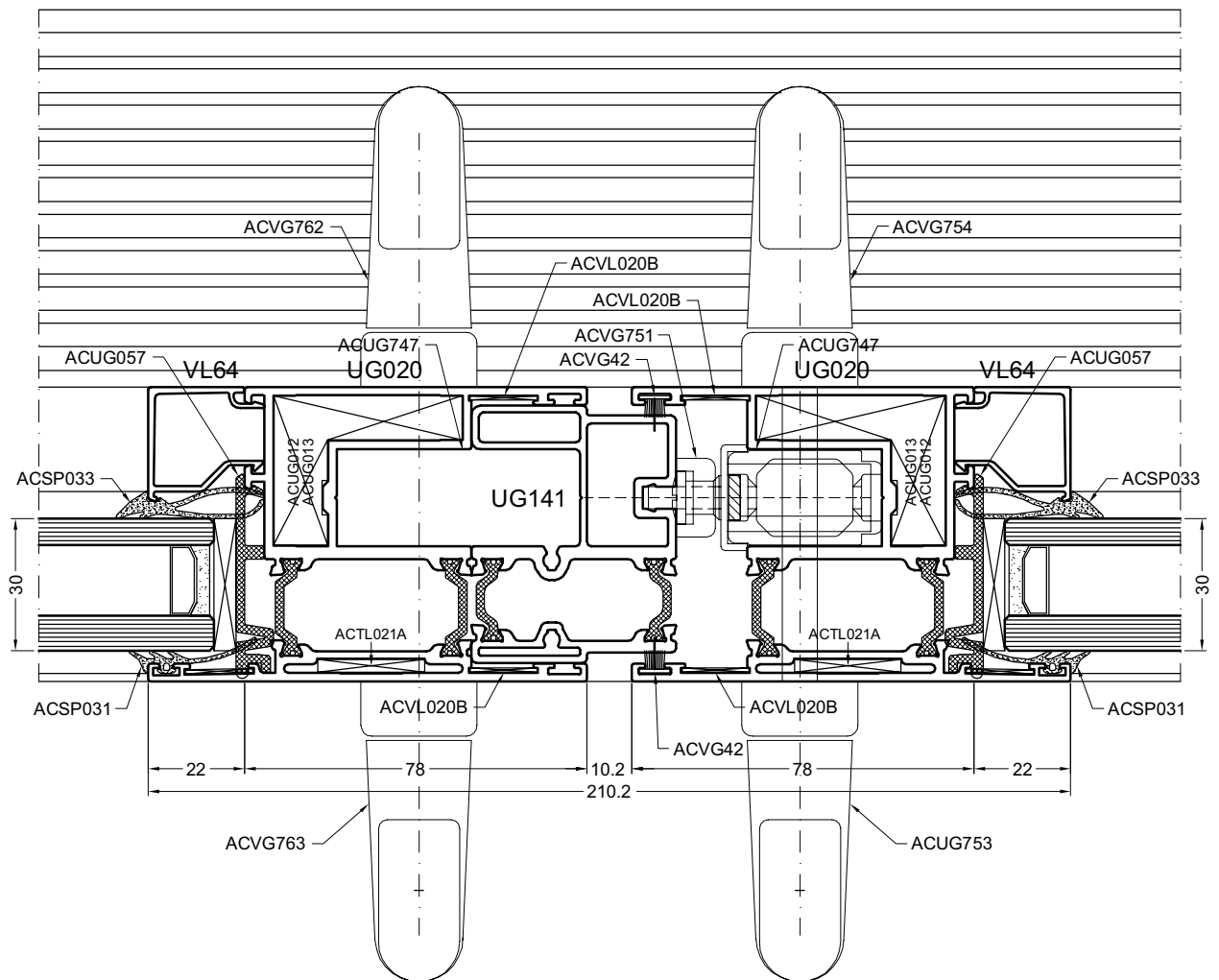

door60a



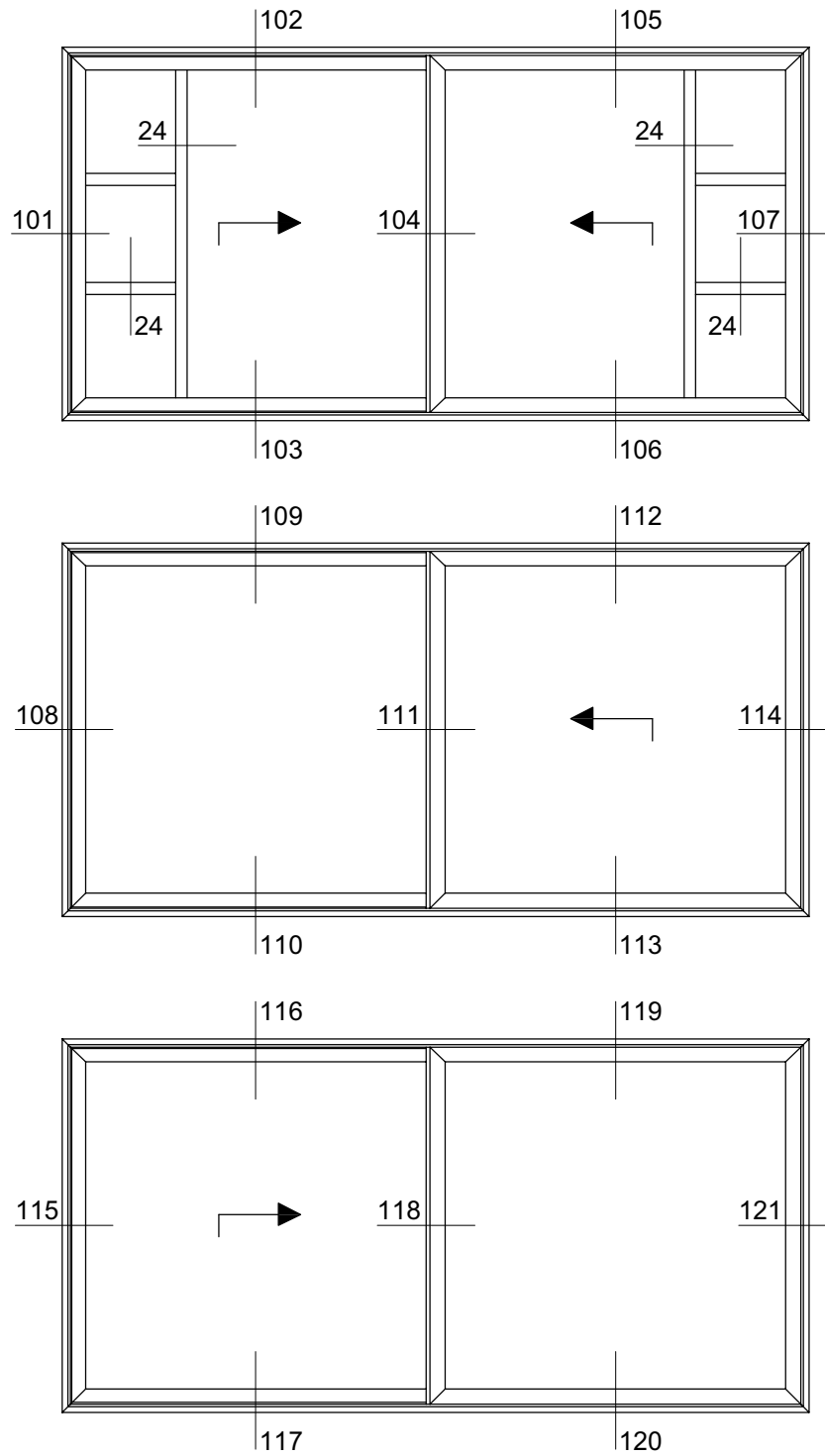

type11

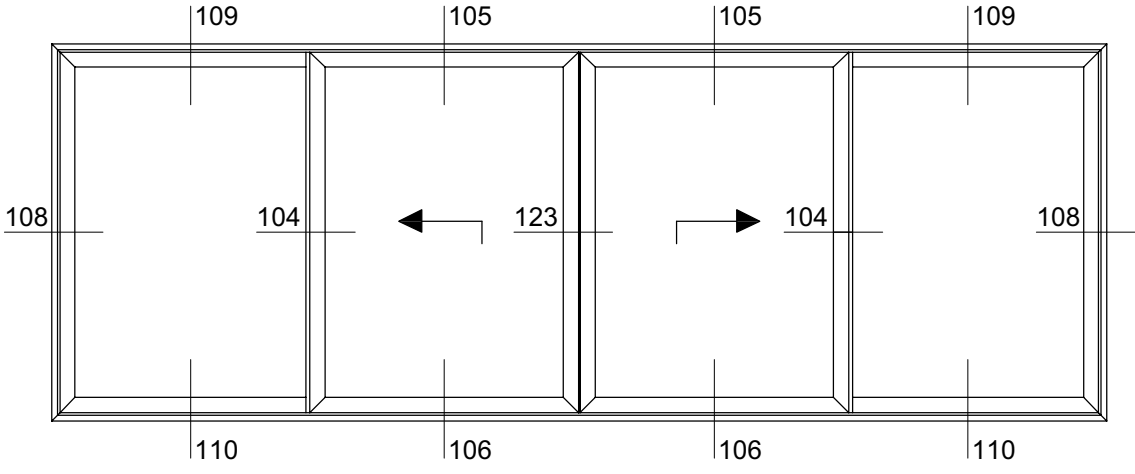
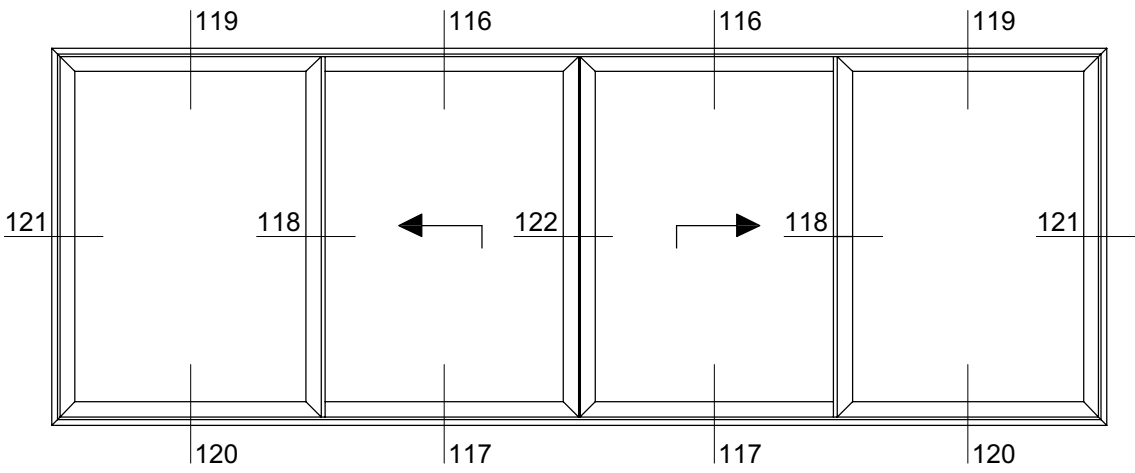
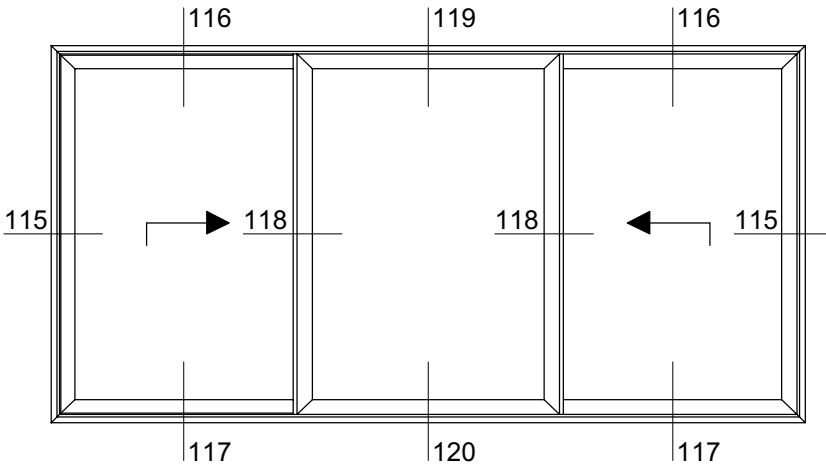

type12

101A

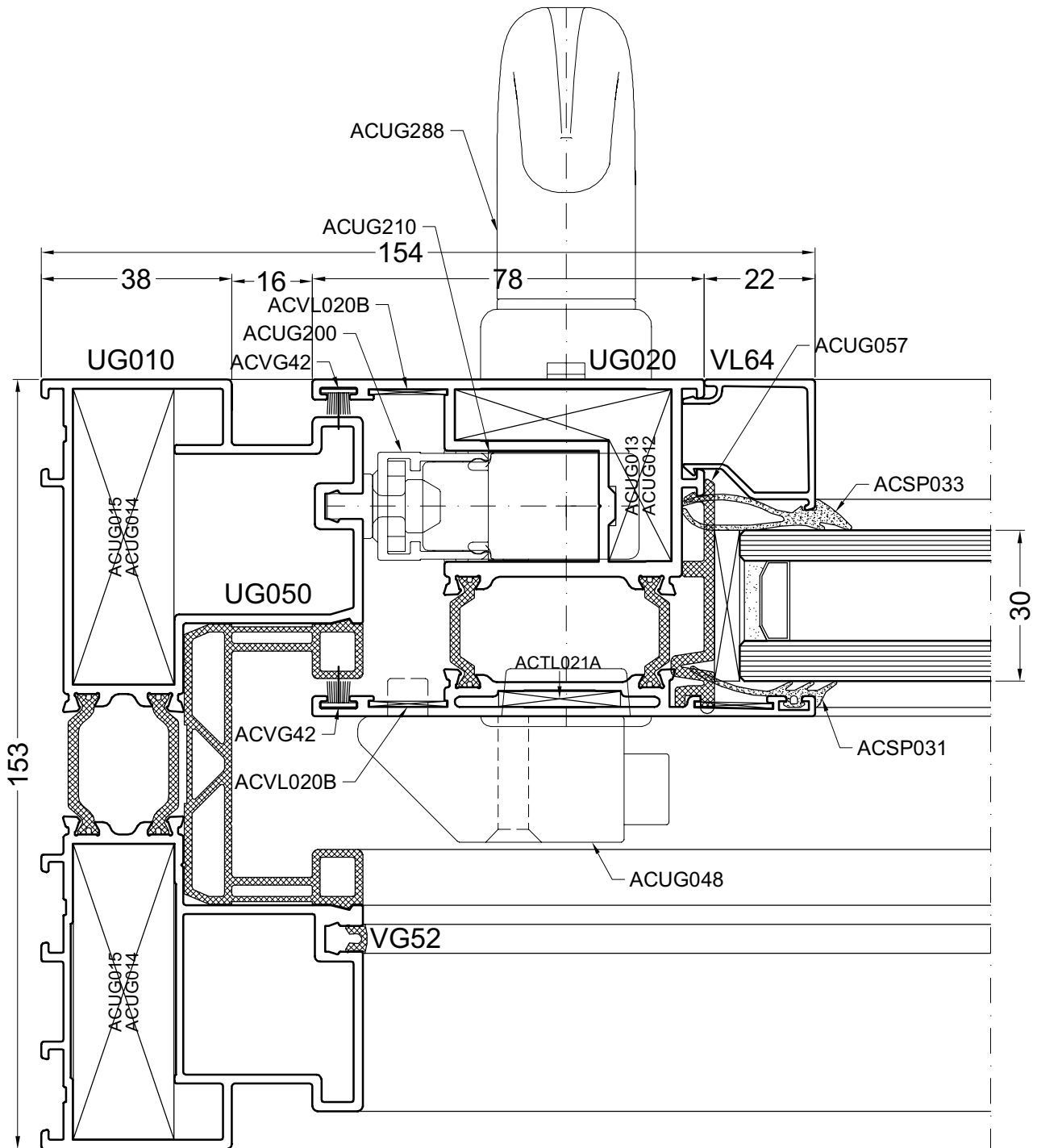

DOORSNEDE - COUPE - SCHNITT - SECTIONS

door101

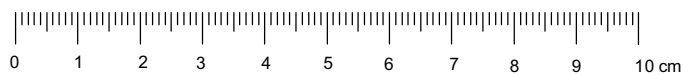

101B

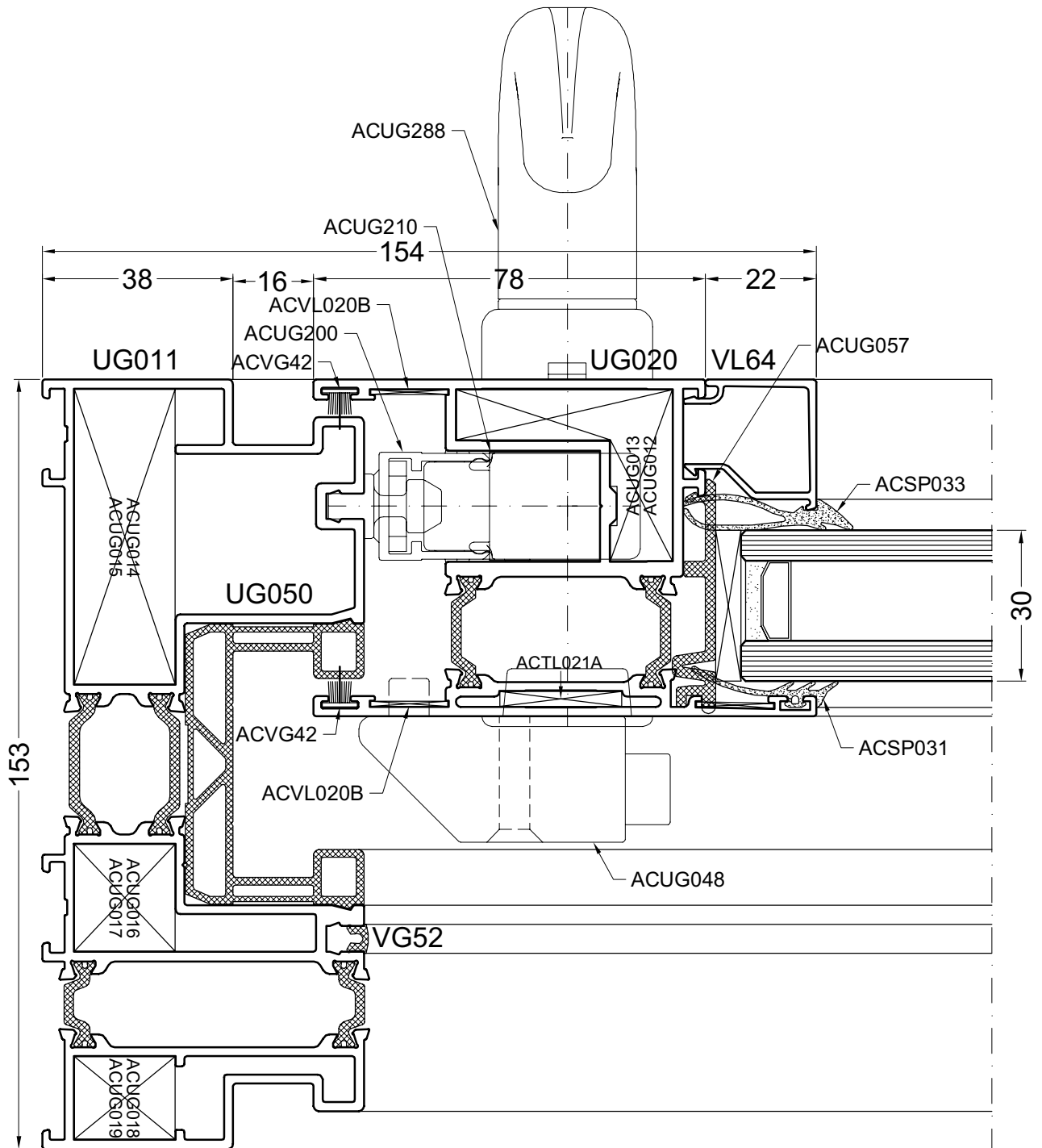

door101a

102A

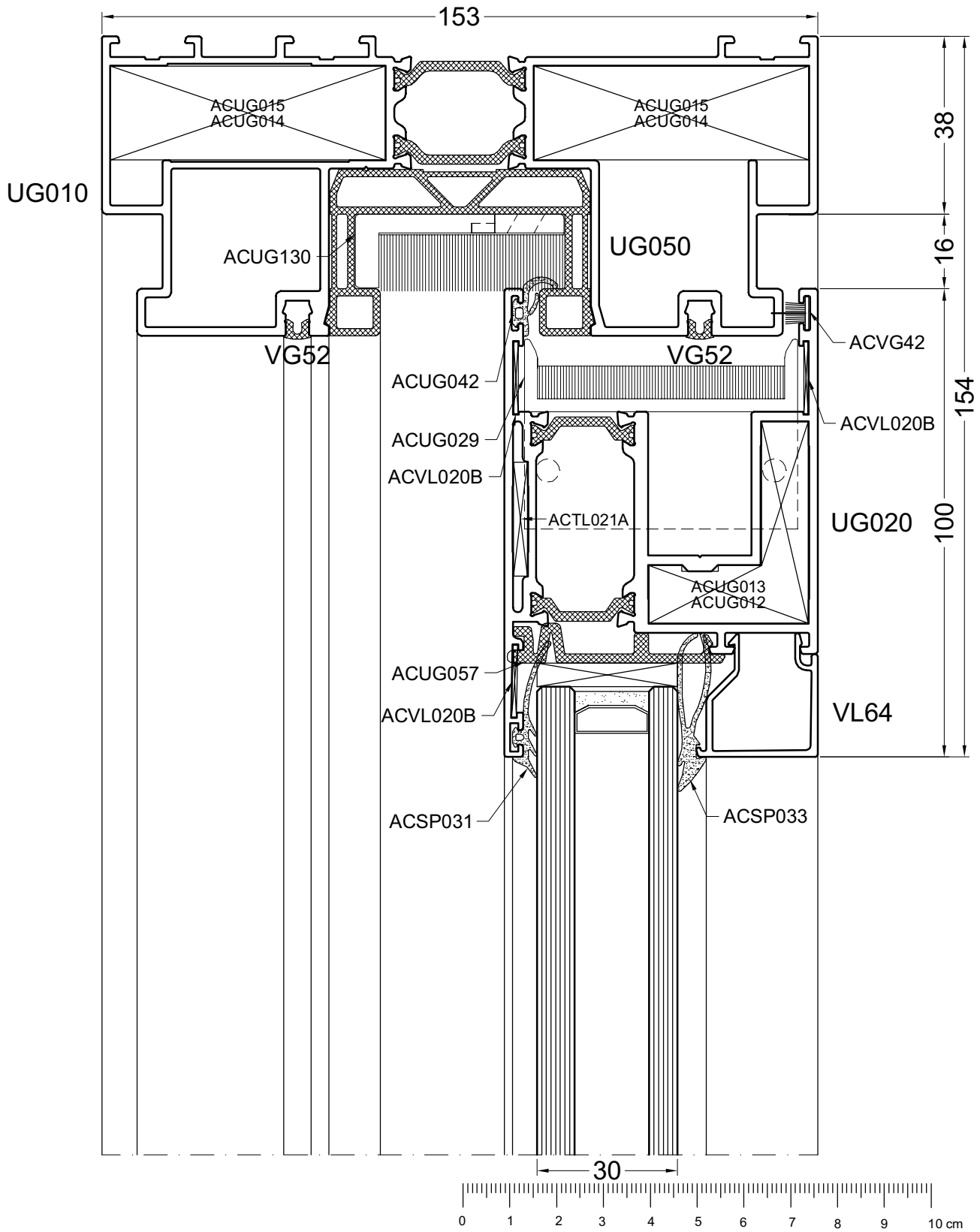

DOORSNEDE - COUPE - SCHNITT - SECTIONS

door102

6/1/2010

BY ALIPLAST

102B

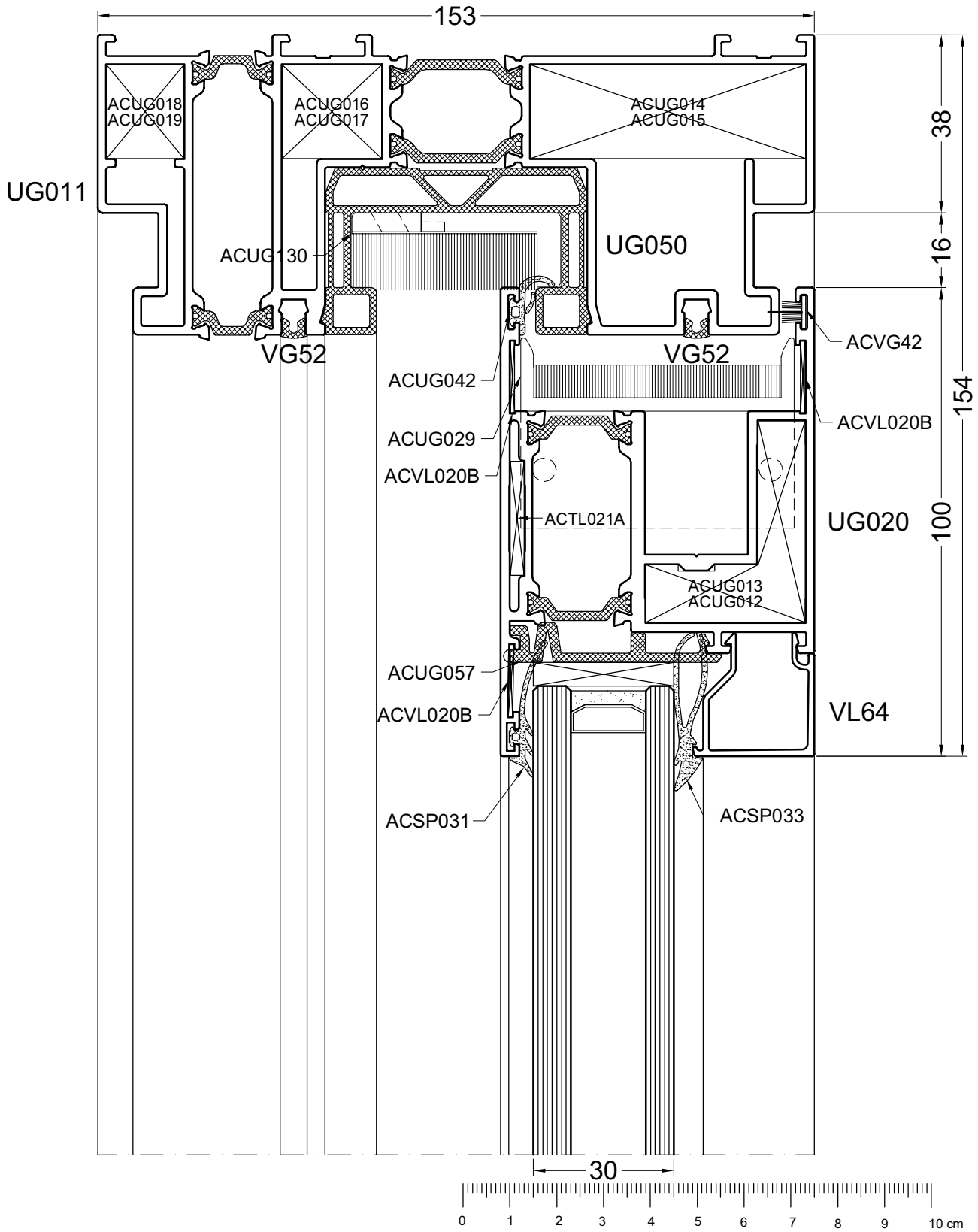

door102a

103A

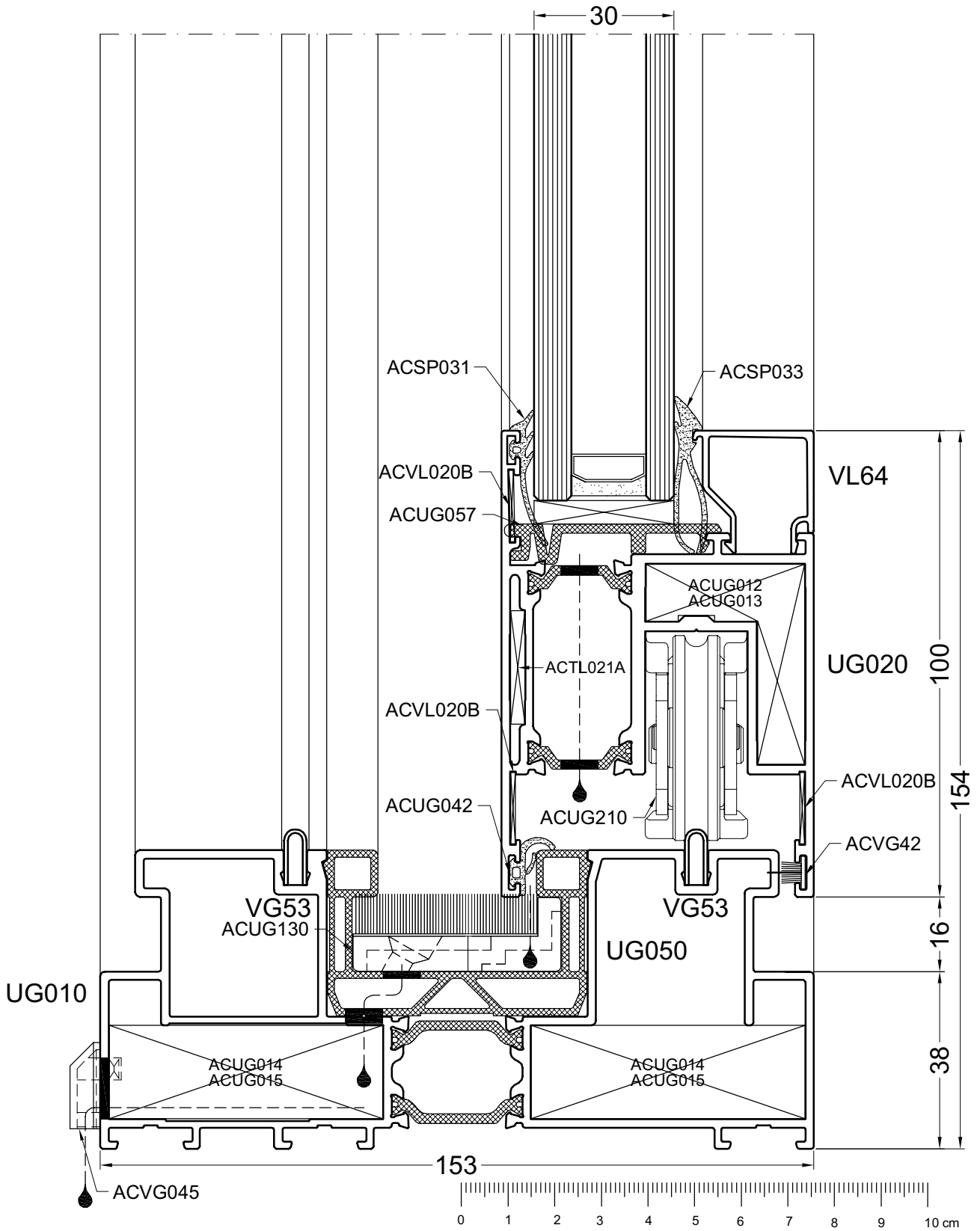

DOORSNEDE - COUPE - SCHNITT - SECTIONS

door103

103B

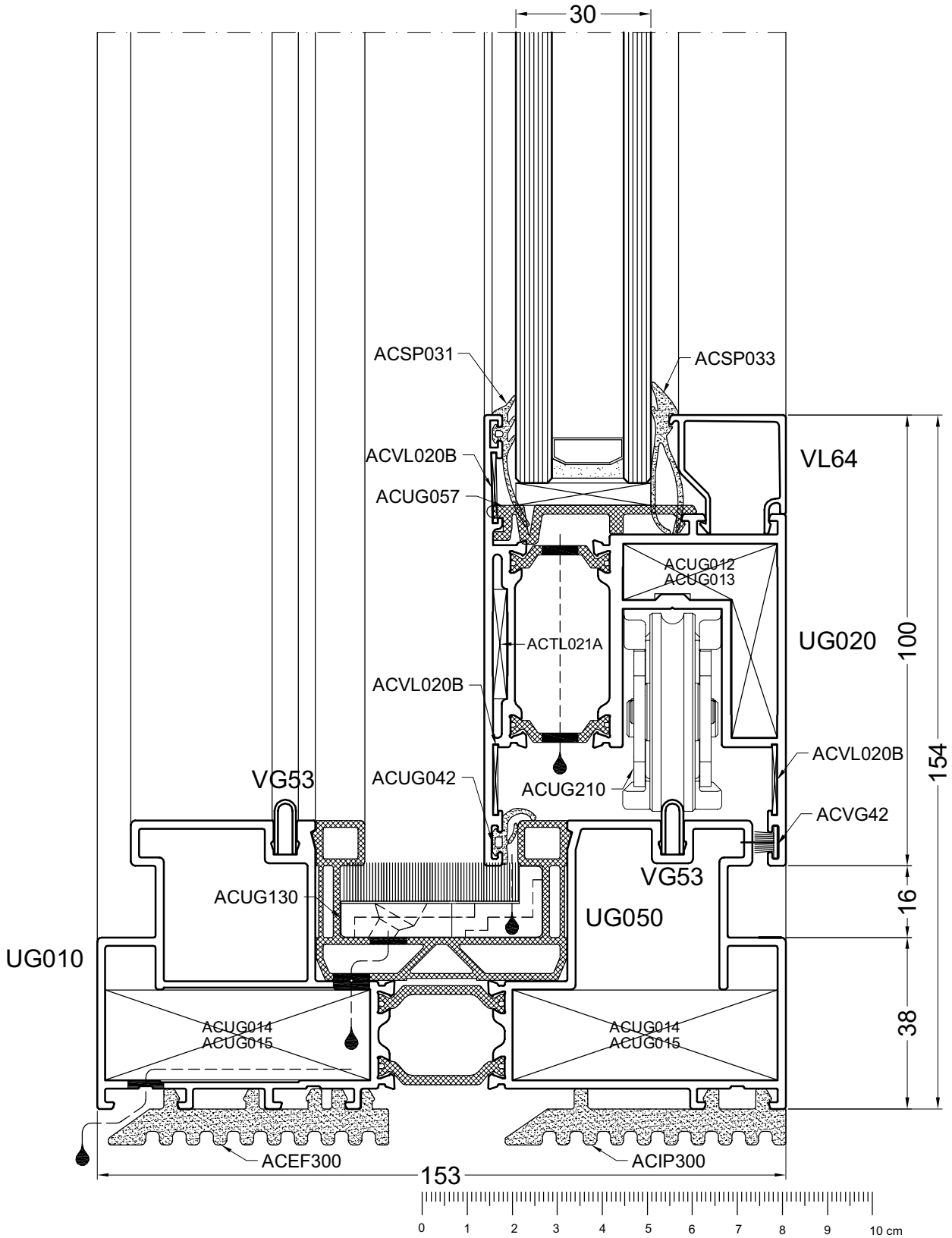

door103a

103C

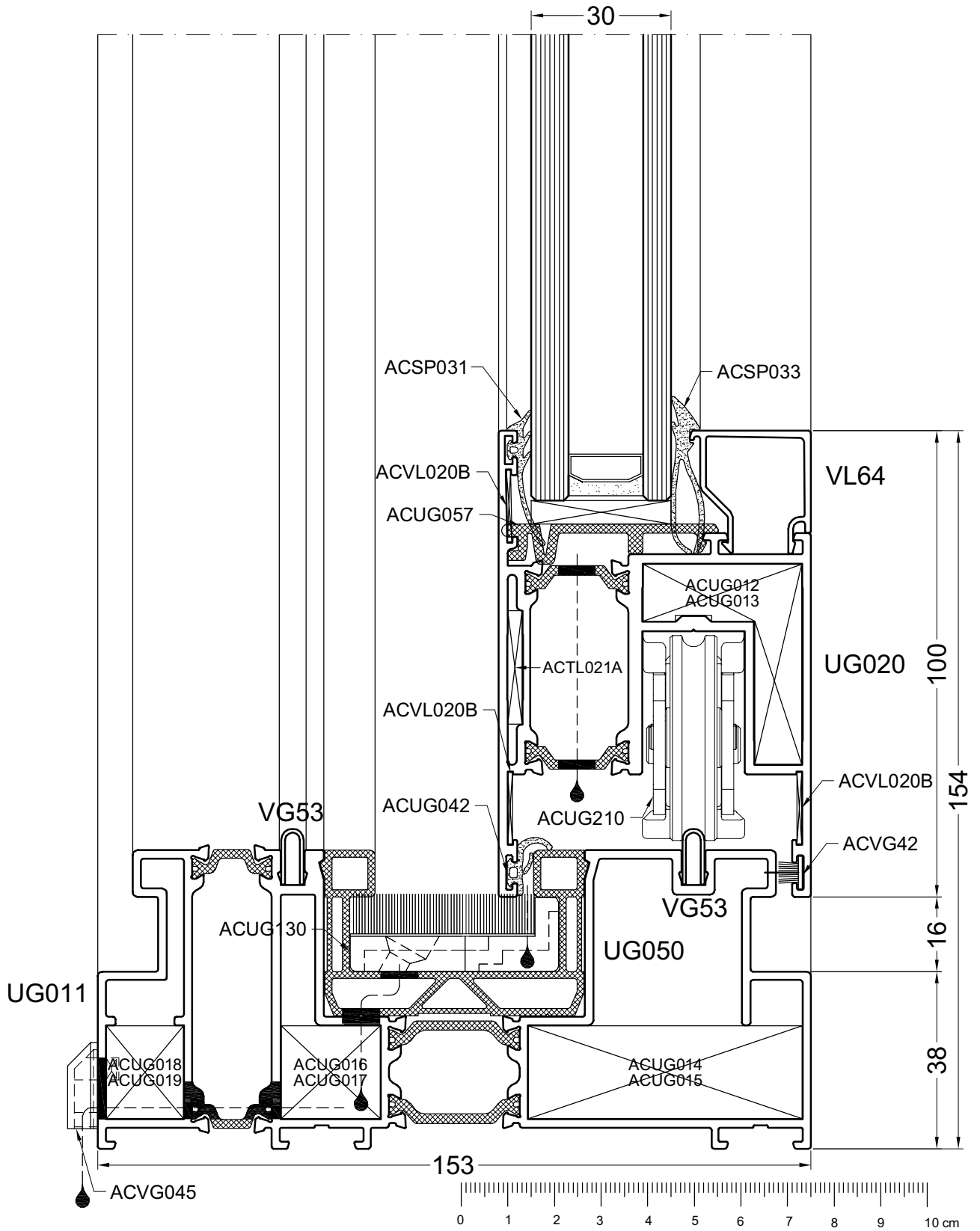

DOORSNEDE - COUPE - SCHNITT - SECTIONS

door103b

104A

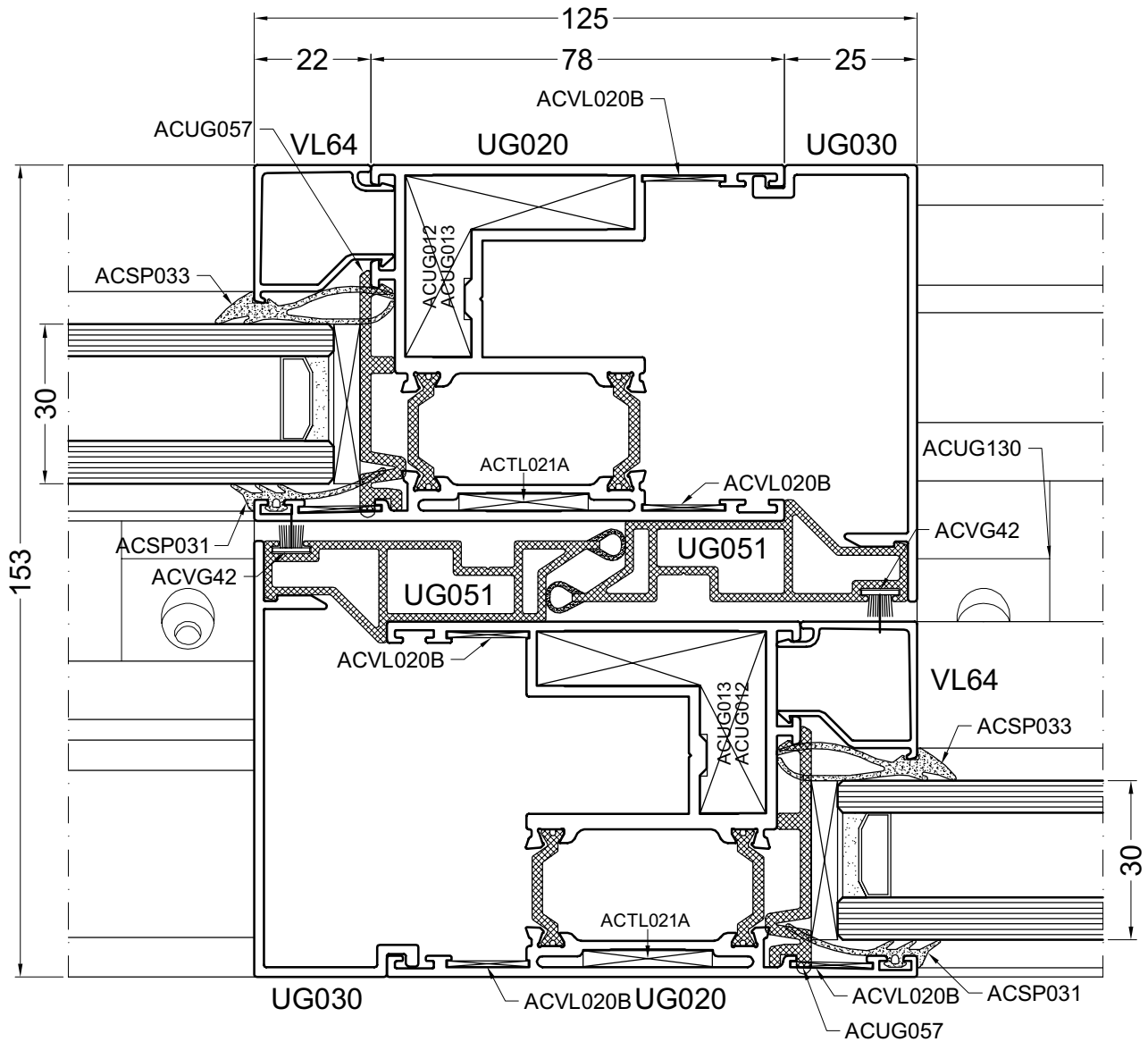

door104

104B

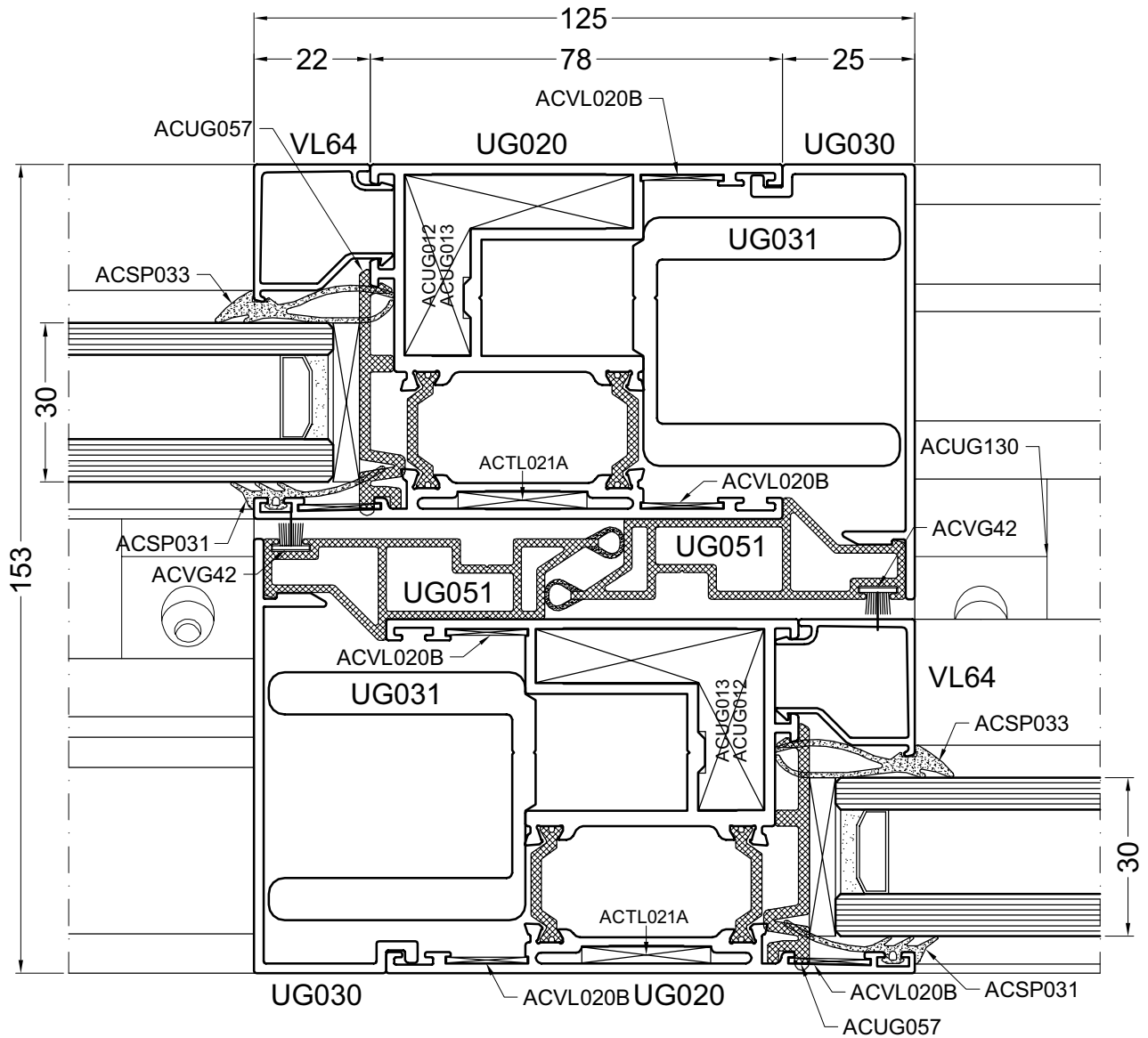

door104a



105A

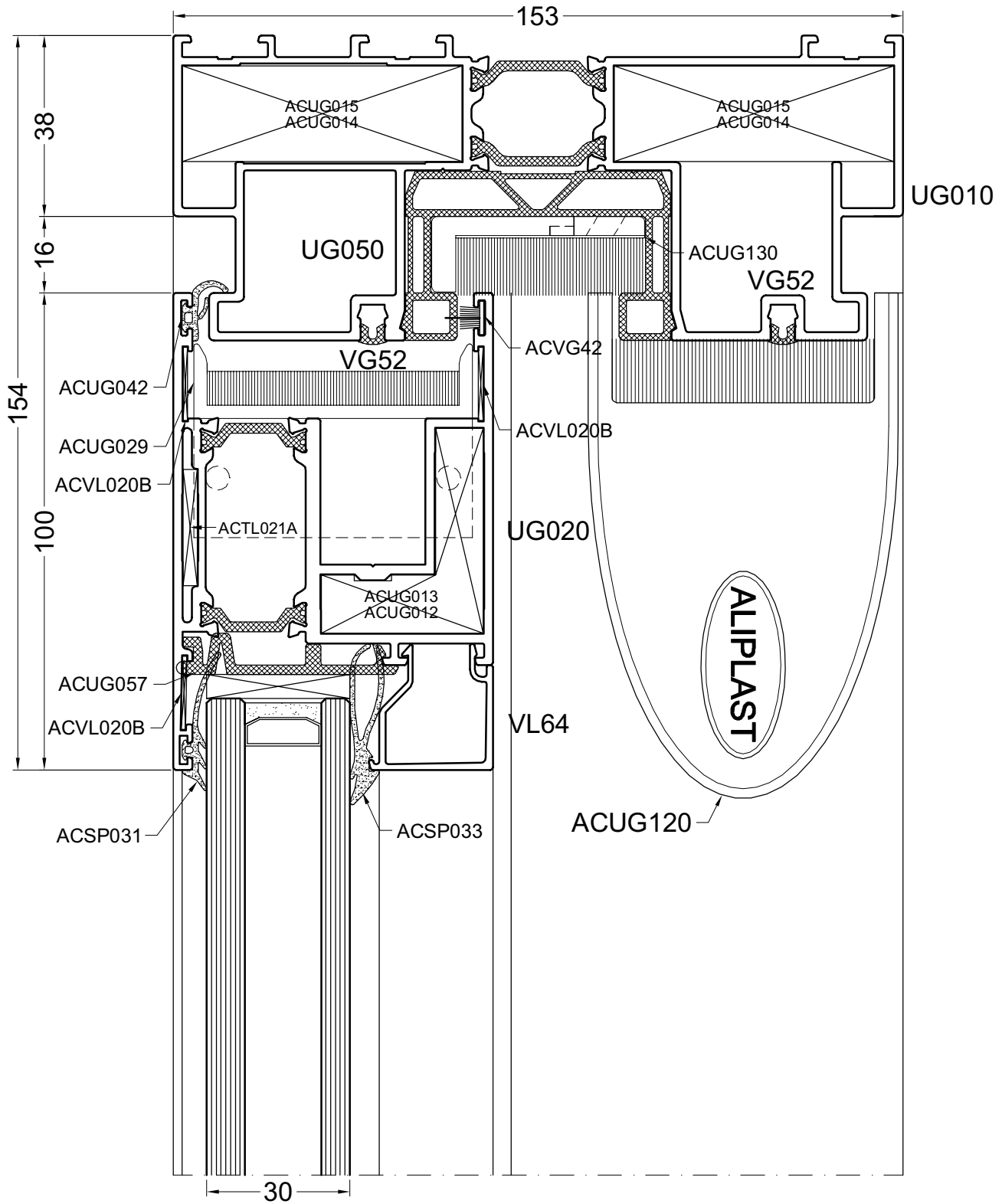

door105

105B

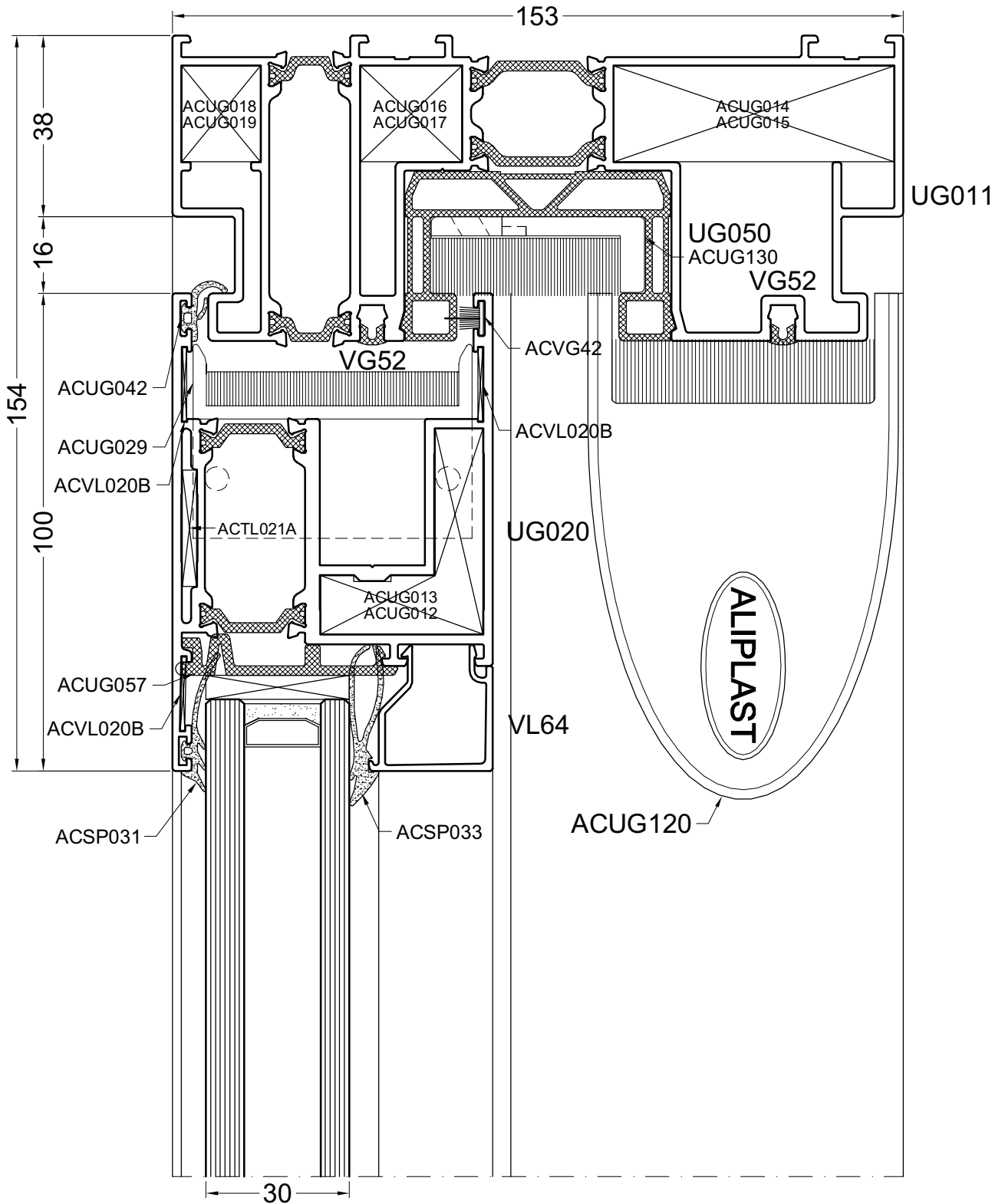

DOORSNEDE - COUPE - SCHNITT - SECTIONS

door105a



106A

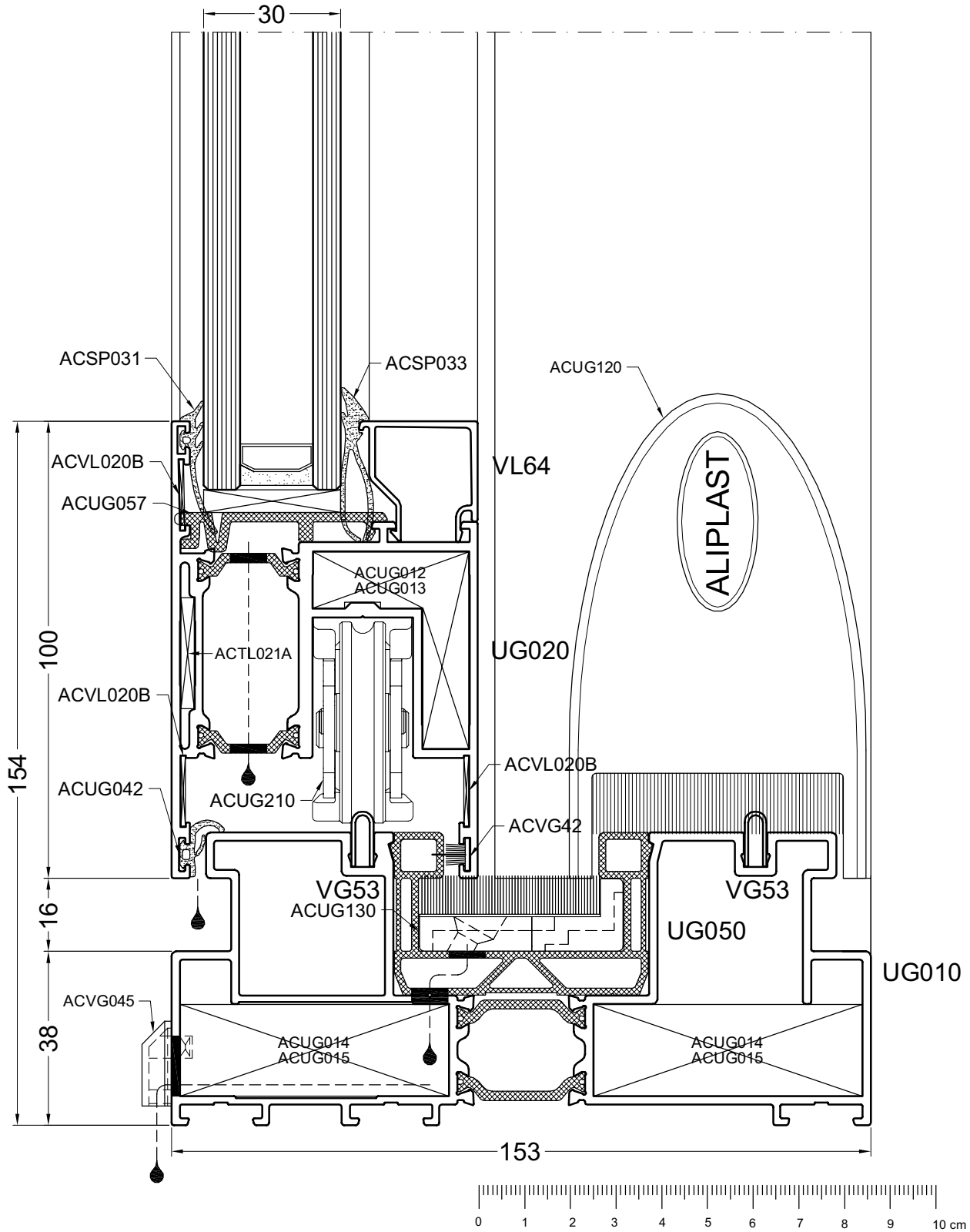

door106

106B

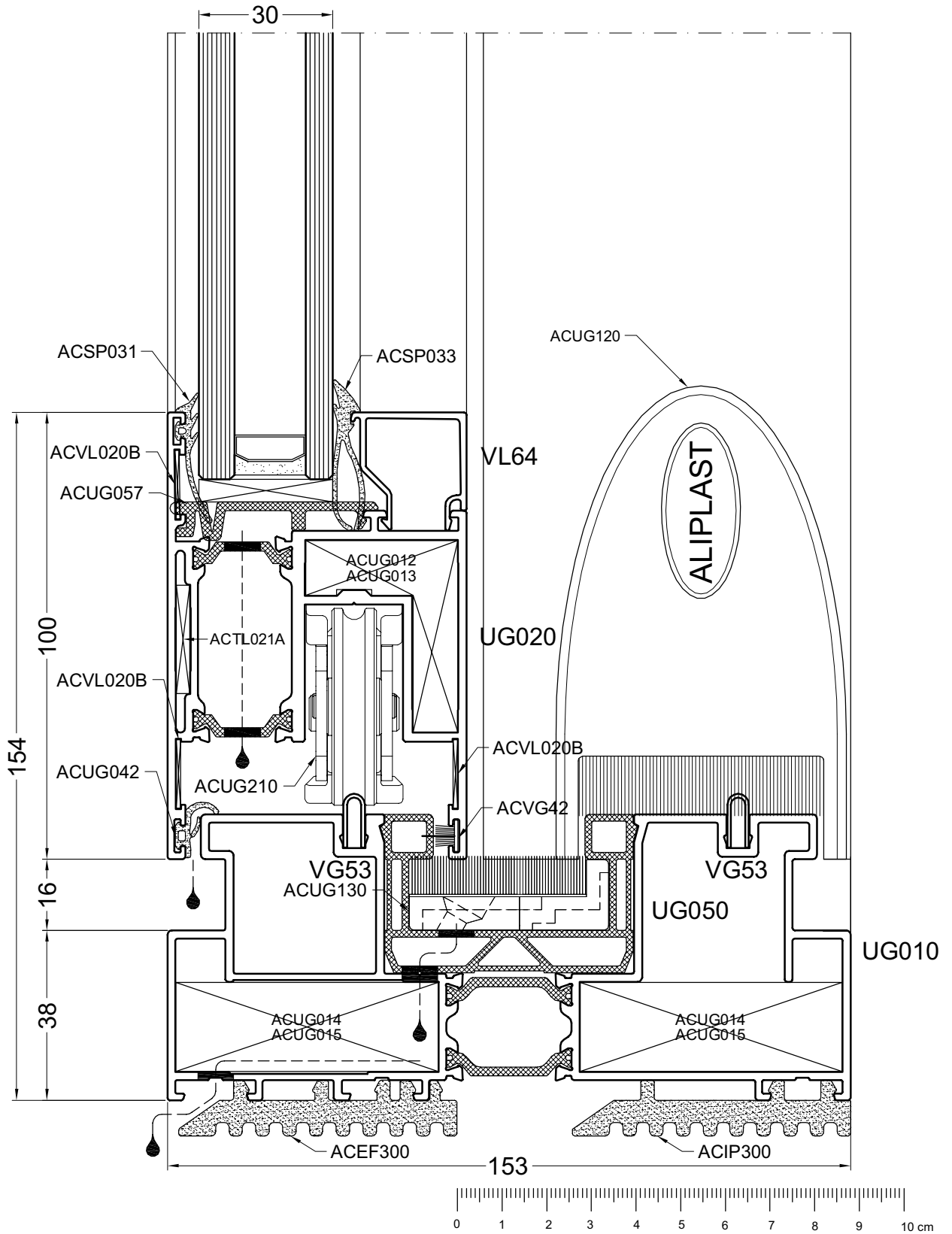

DOORSNEDE - COUPE - SCHNITT - SECTIONS

door106a

106C

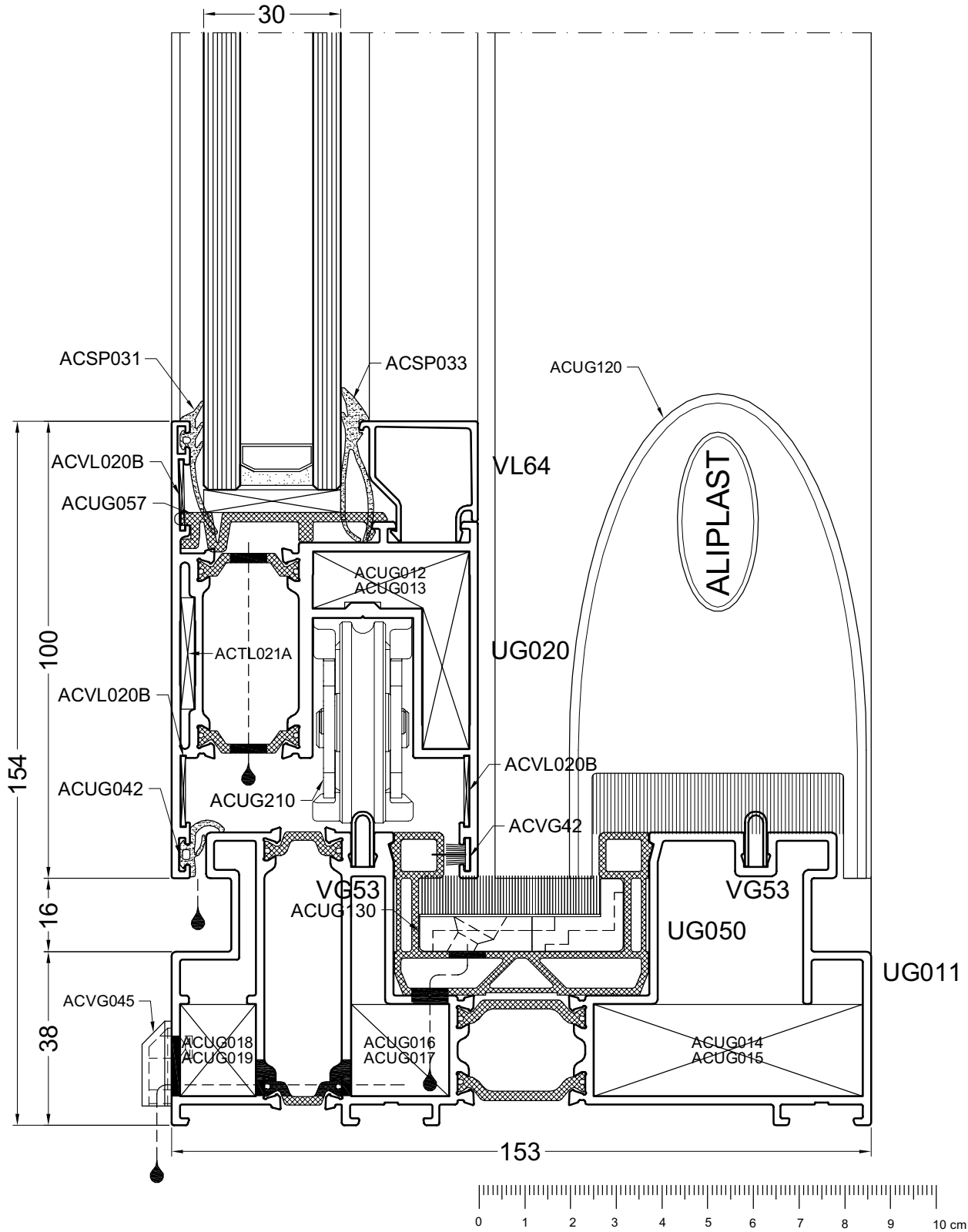

door106b

107A

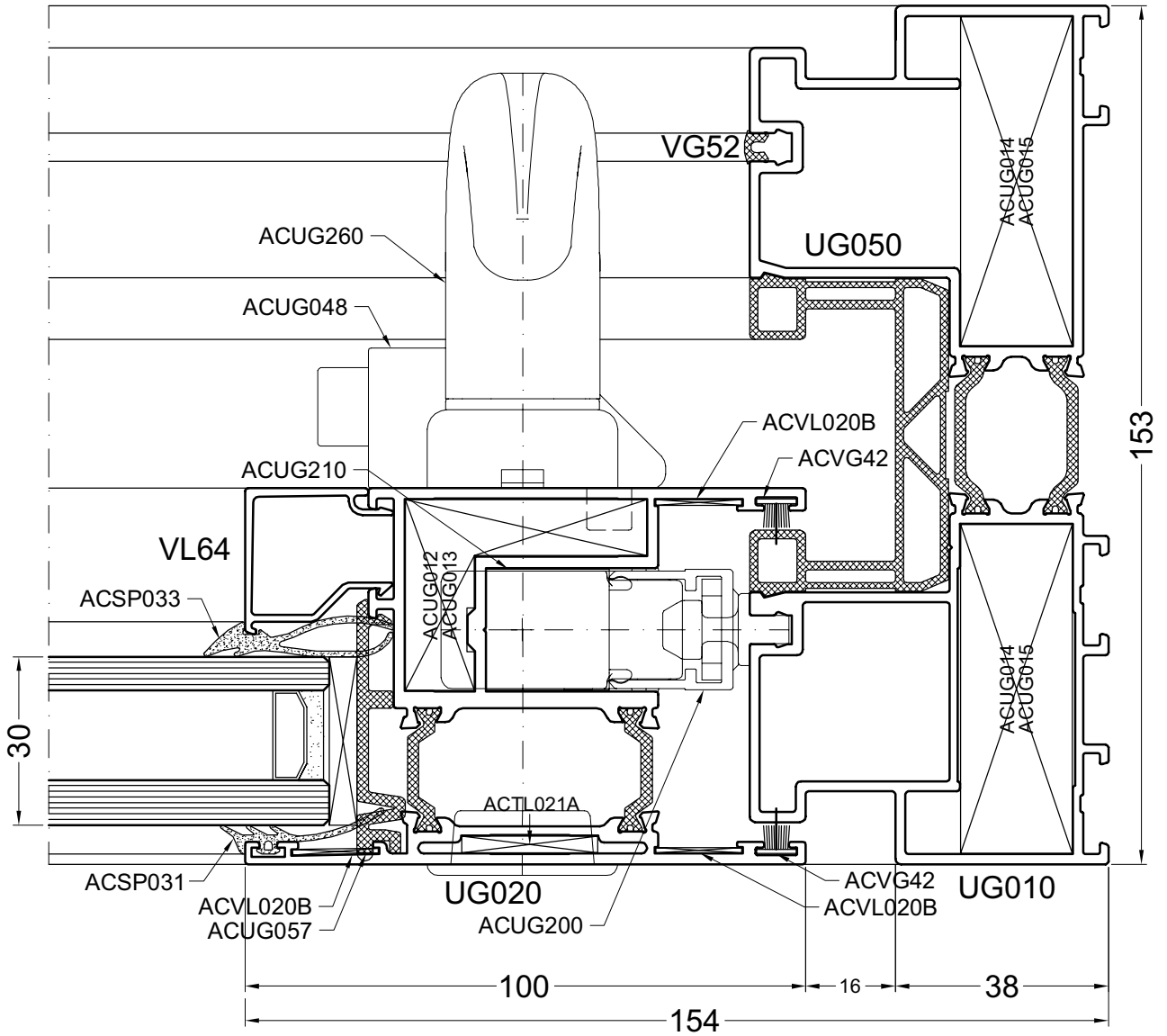

DOORSNEDE - COUPE - SCHNITT - SECTIONS

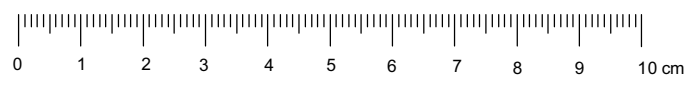

door107

107B

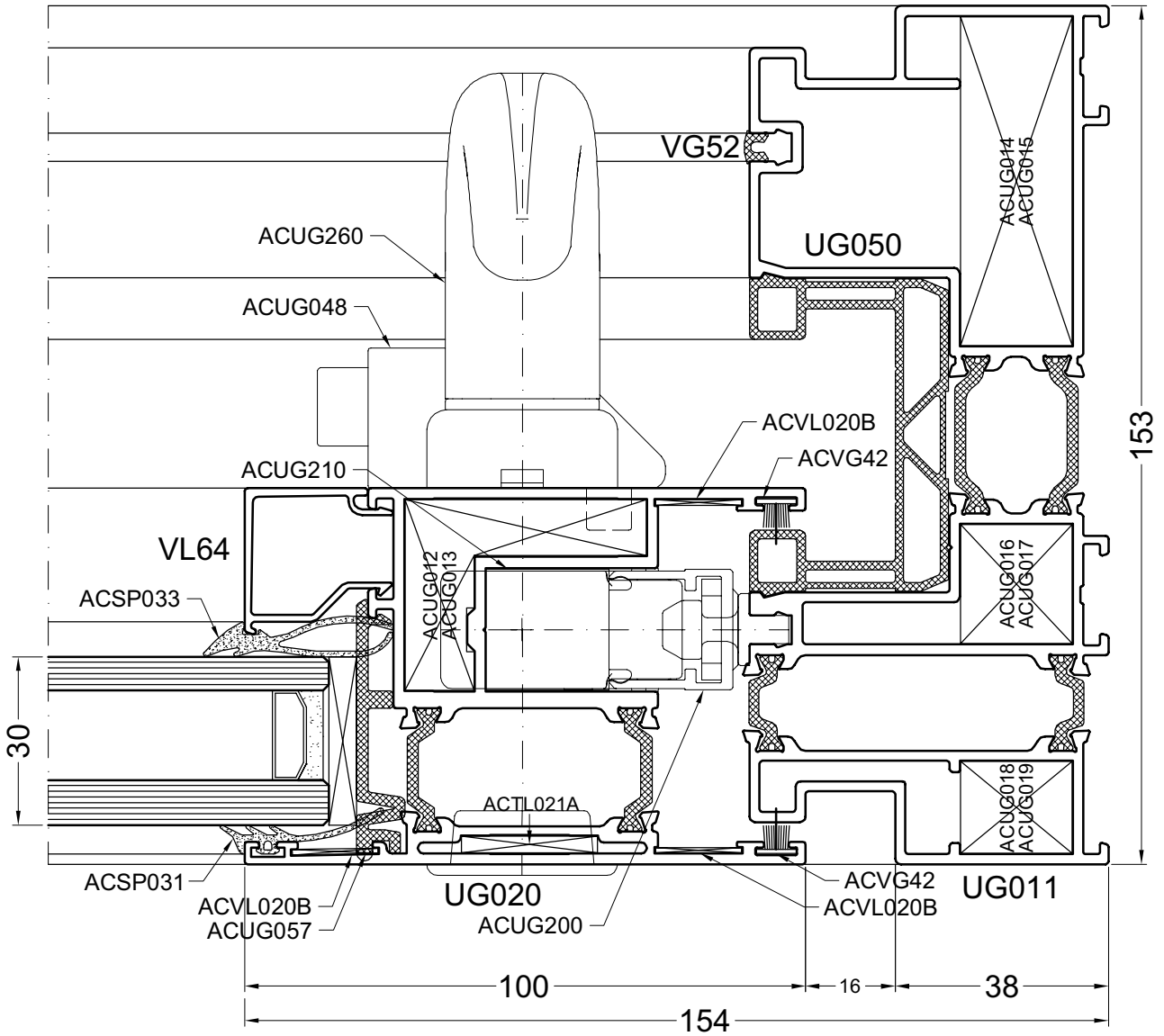

door107a

108A

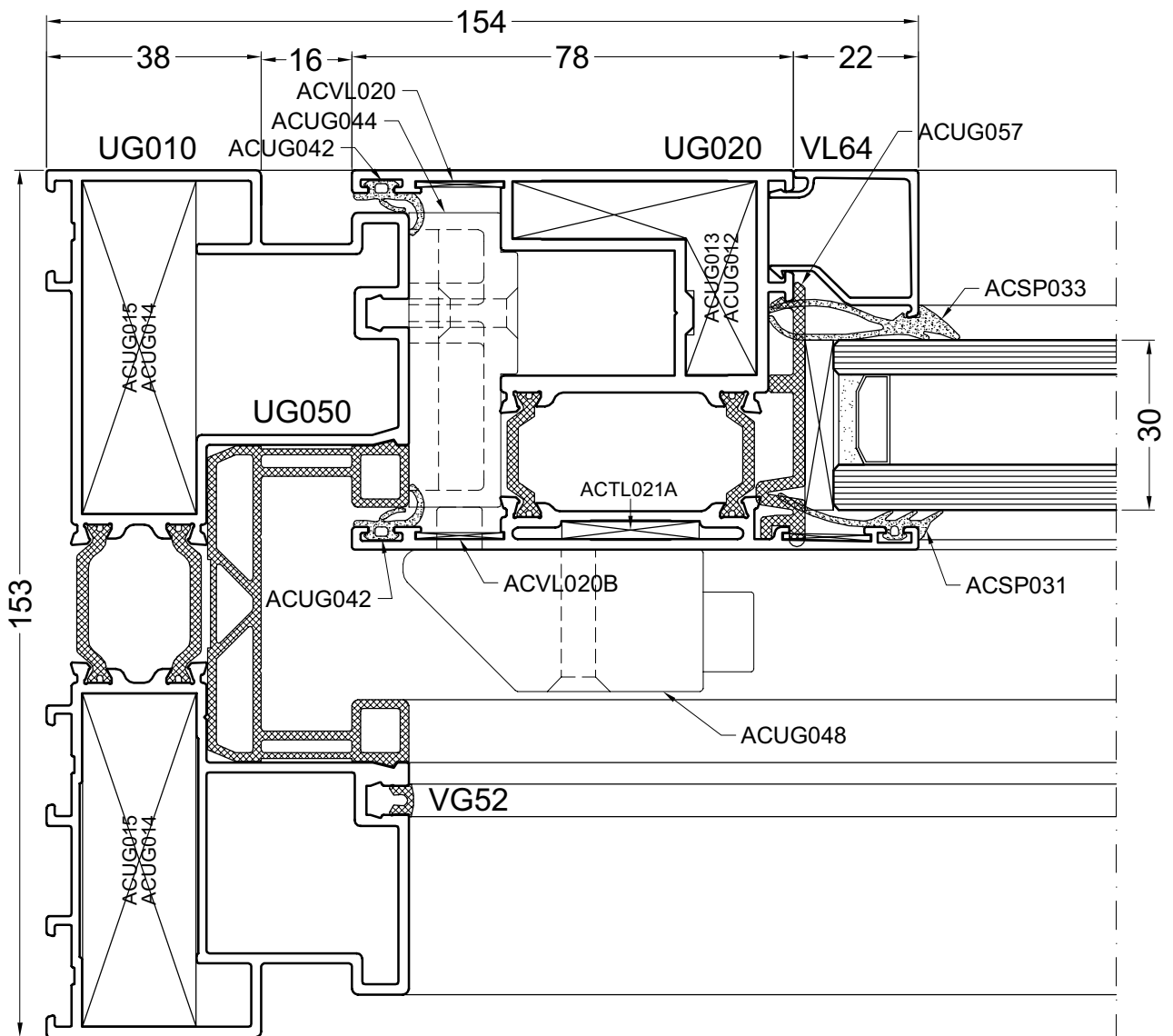

DOORSNEDE - COUPE - SCHNITT - SECTIONS

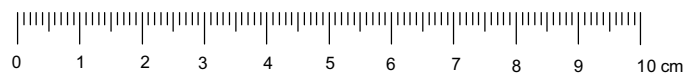

door108

108B

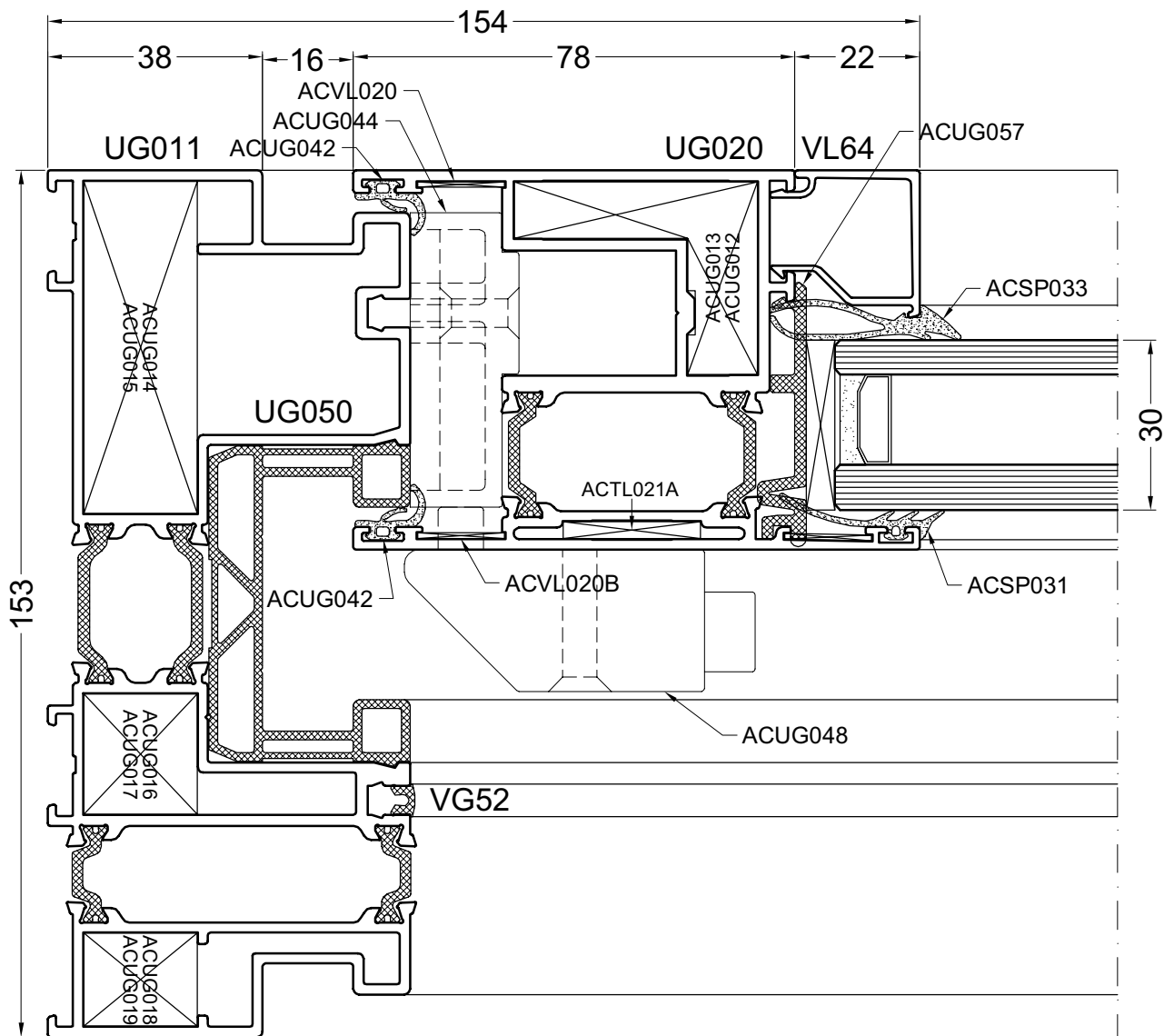

door108a

109A

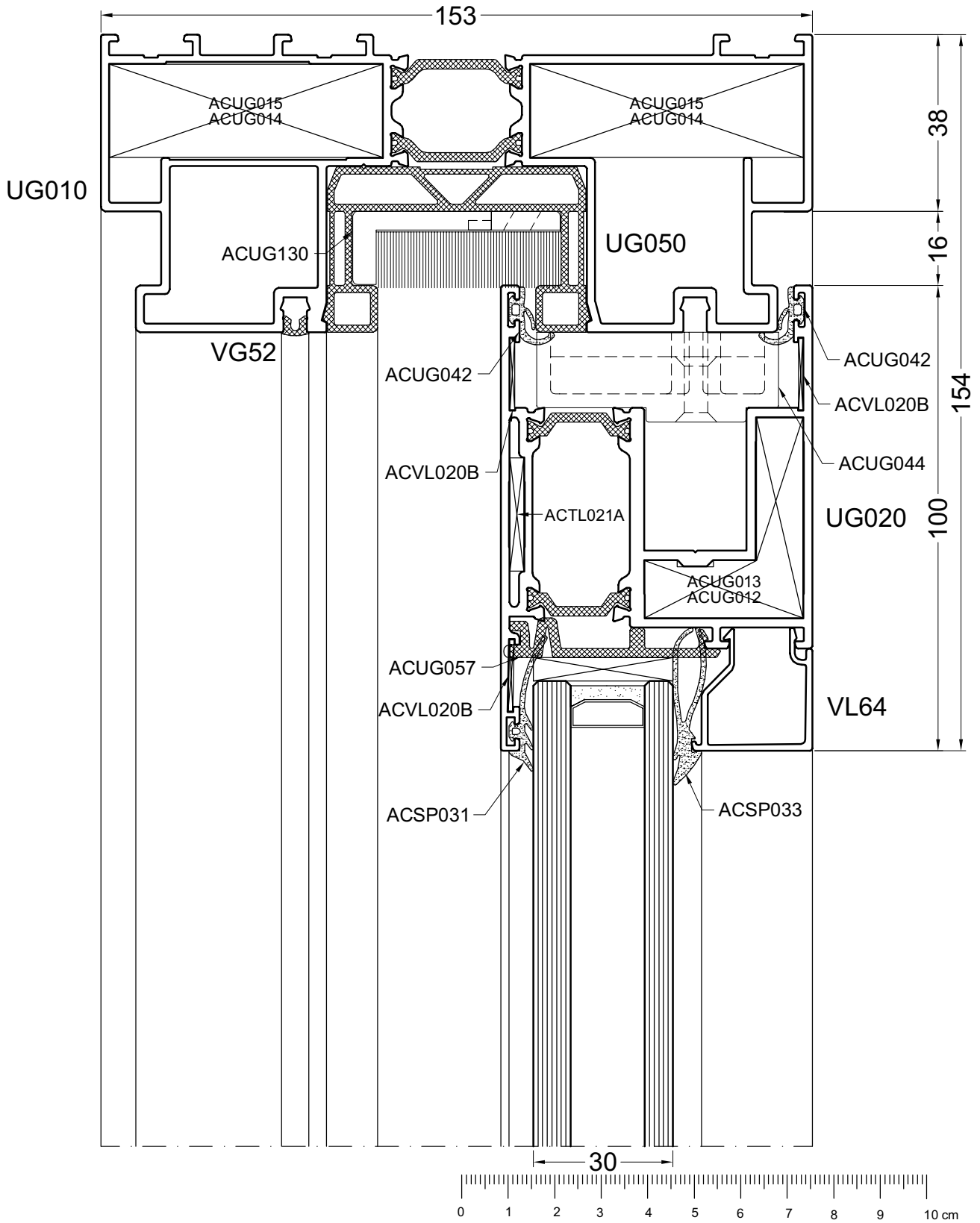

DOORSNEDE - COUPE - SCHNITT - SECTIONS

door109

109B

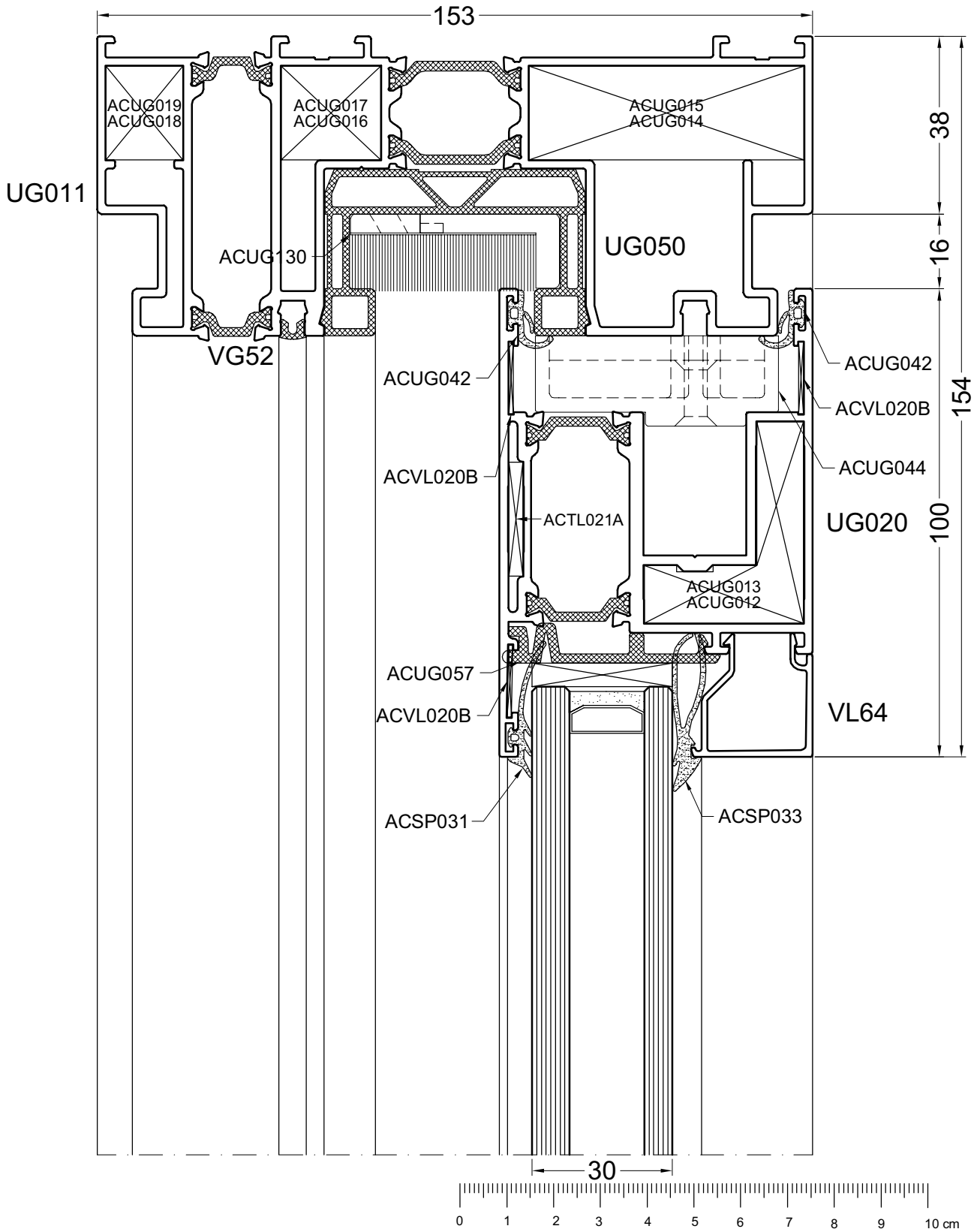

door109a

110A

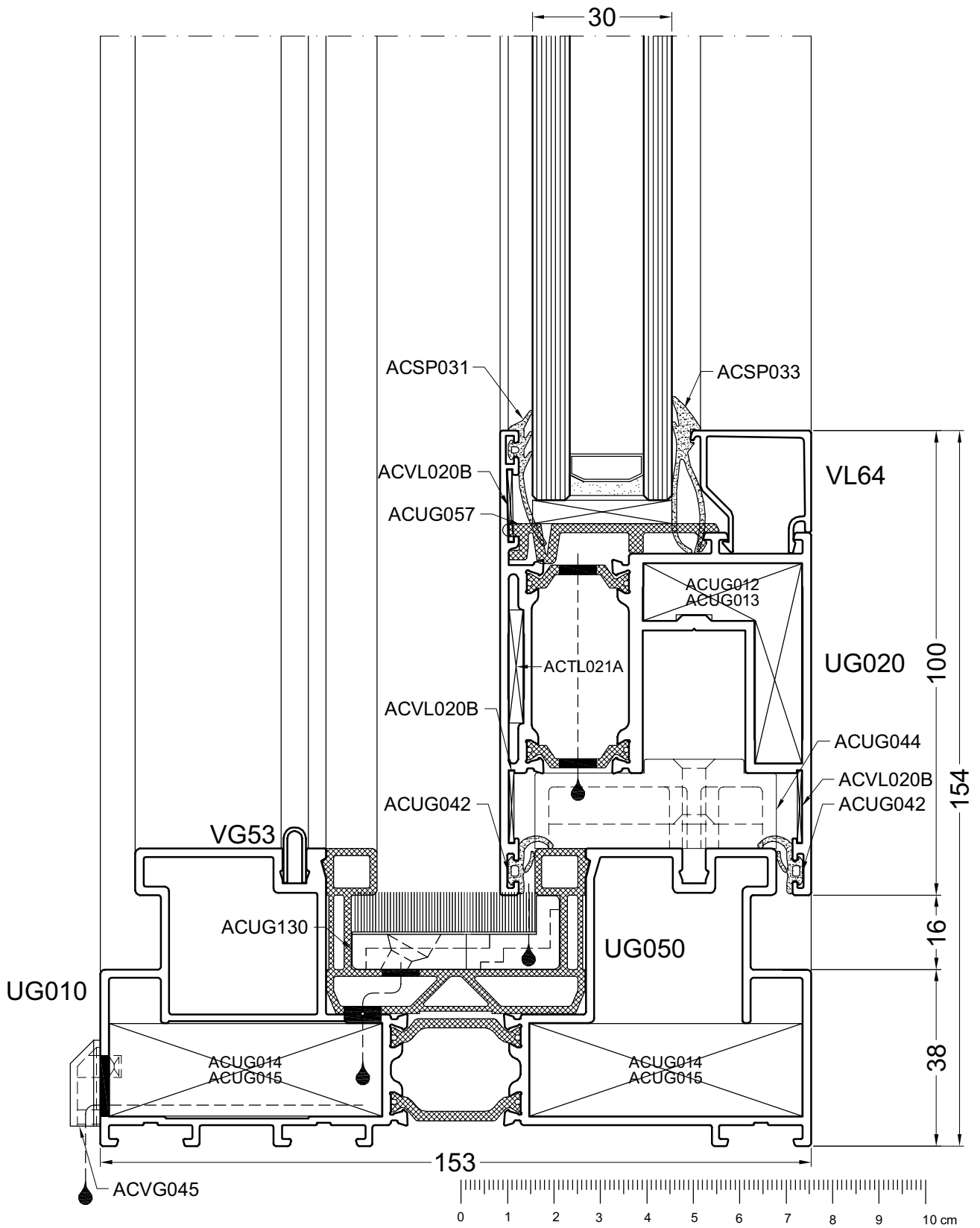

DOORSNEDE - COUPE - SCHNITT - SECTIONS

door110

110B

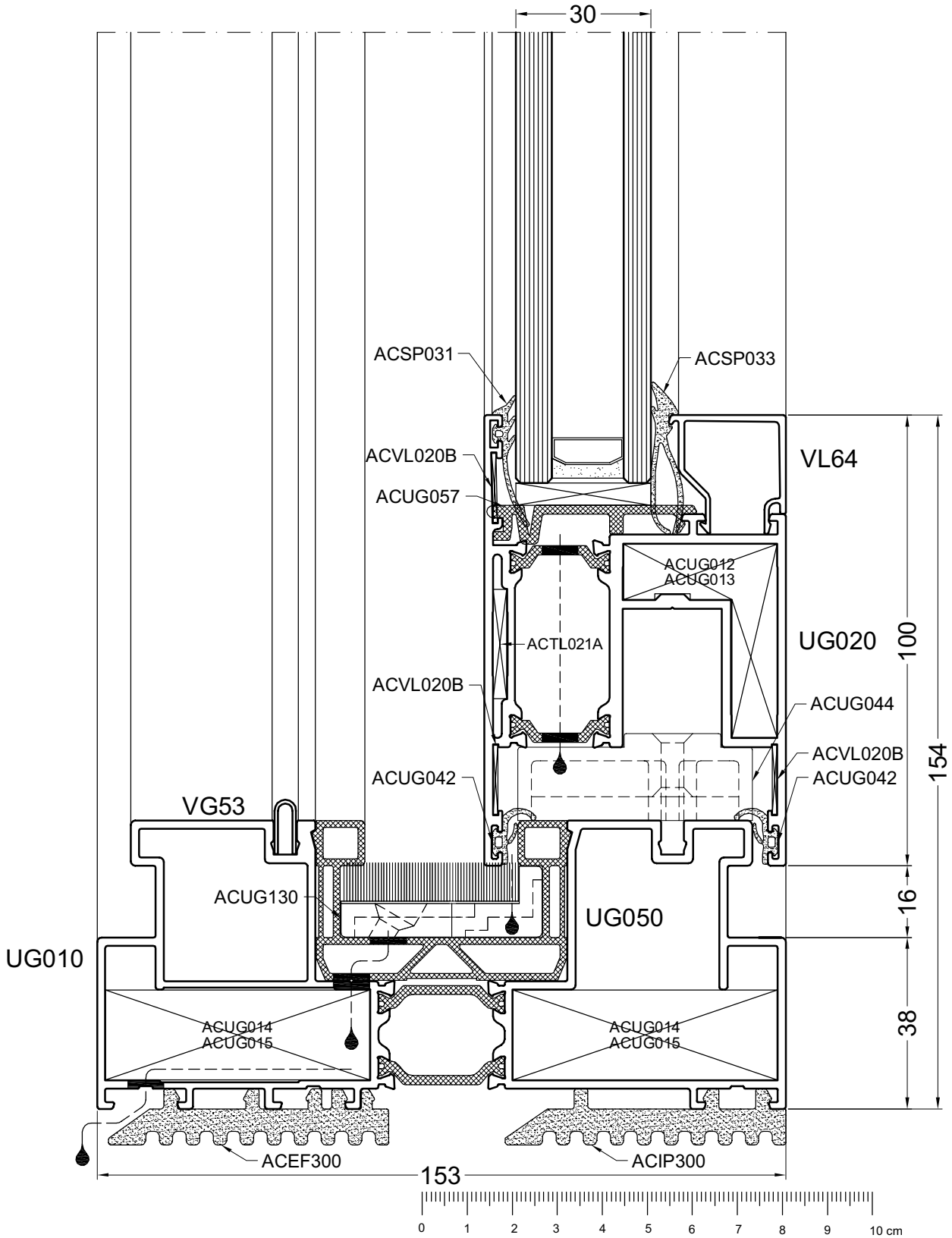

door110a

110C

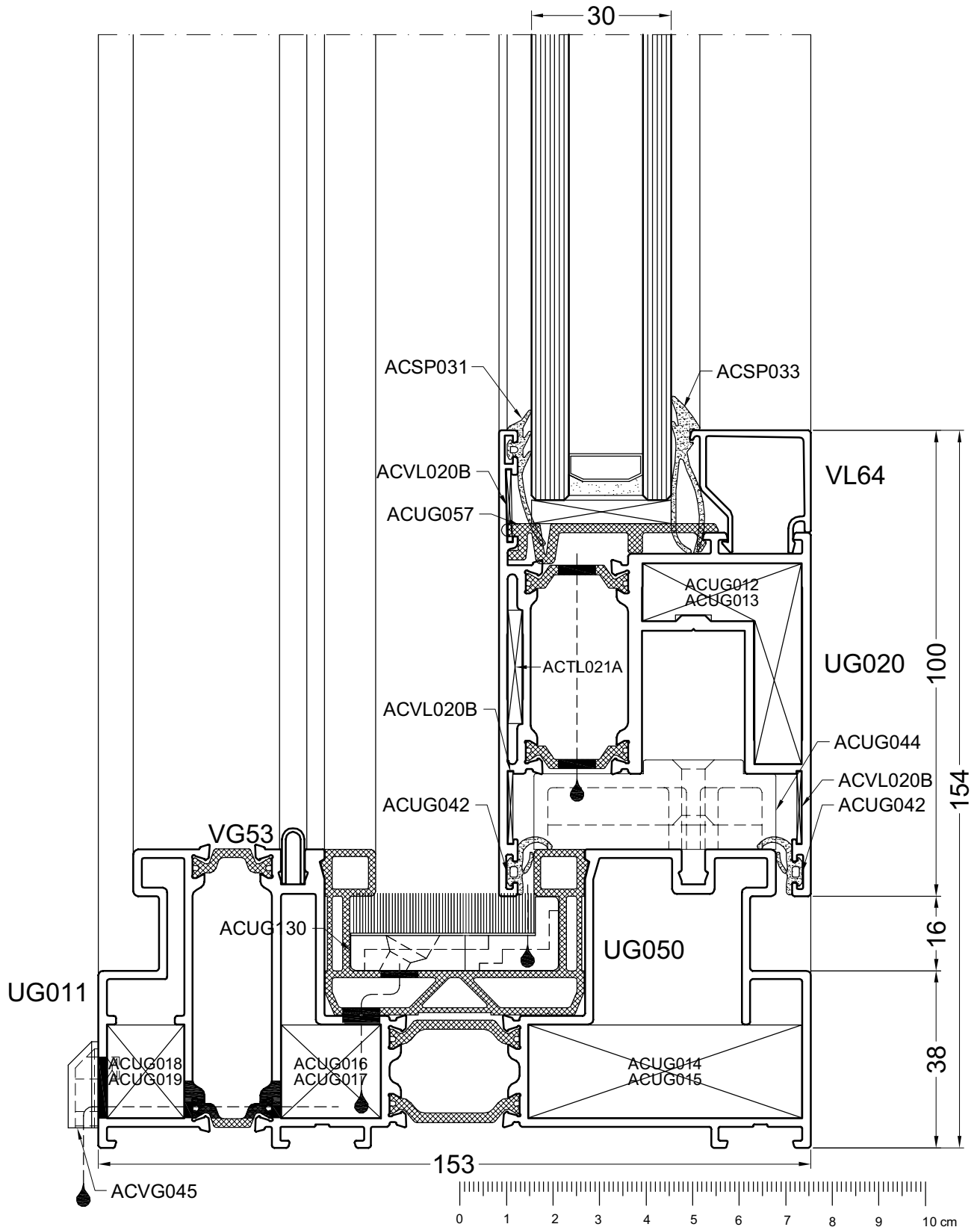

DOORSNEDE - COUPE - SCHNITT - SECTIONS

door110b

111A

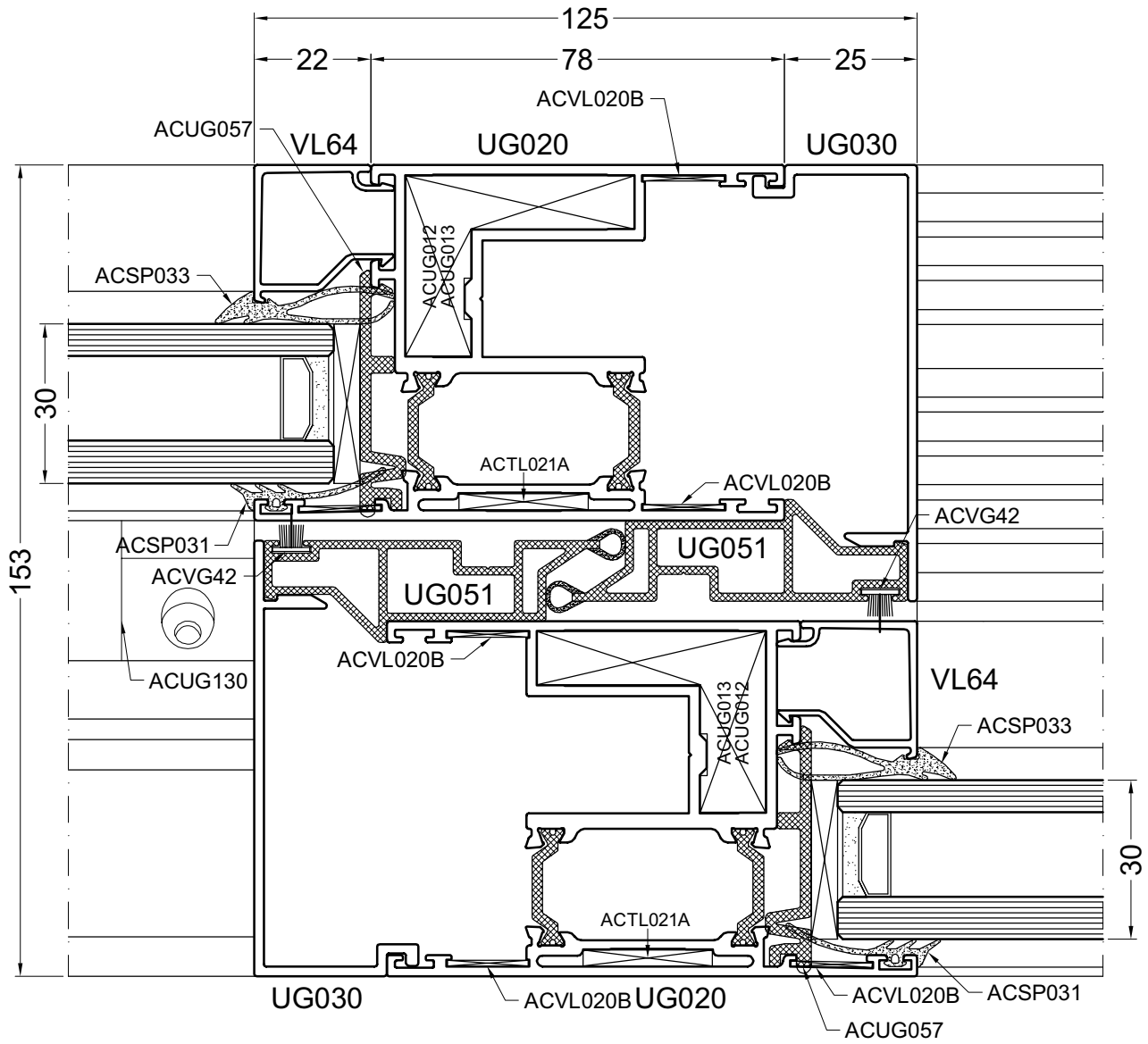

door111

111B

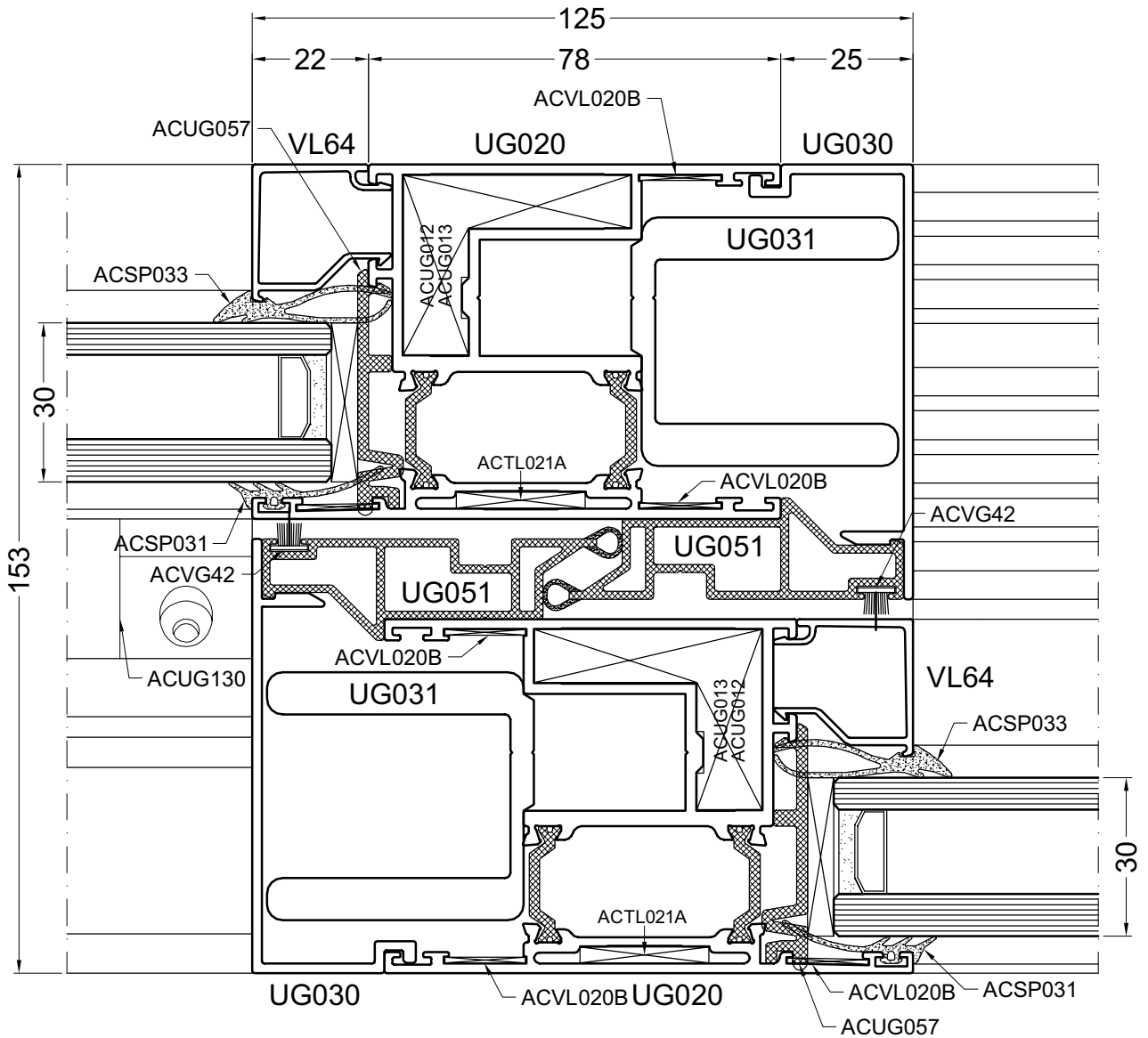

door111a

112A

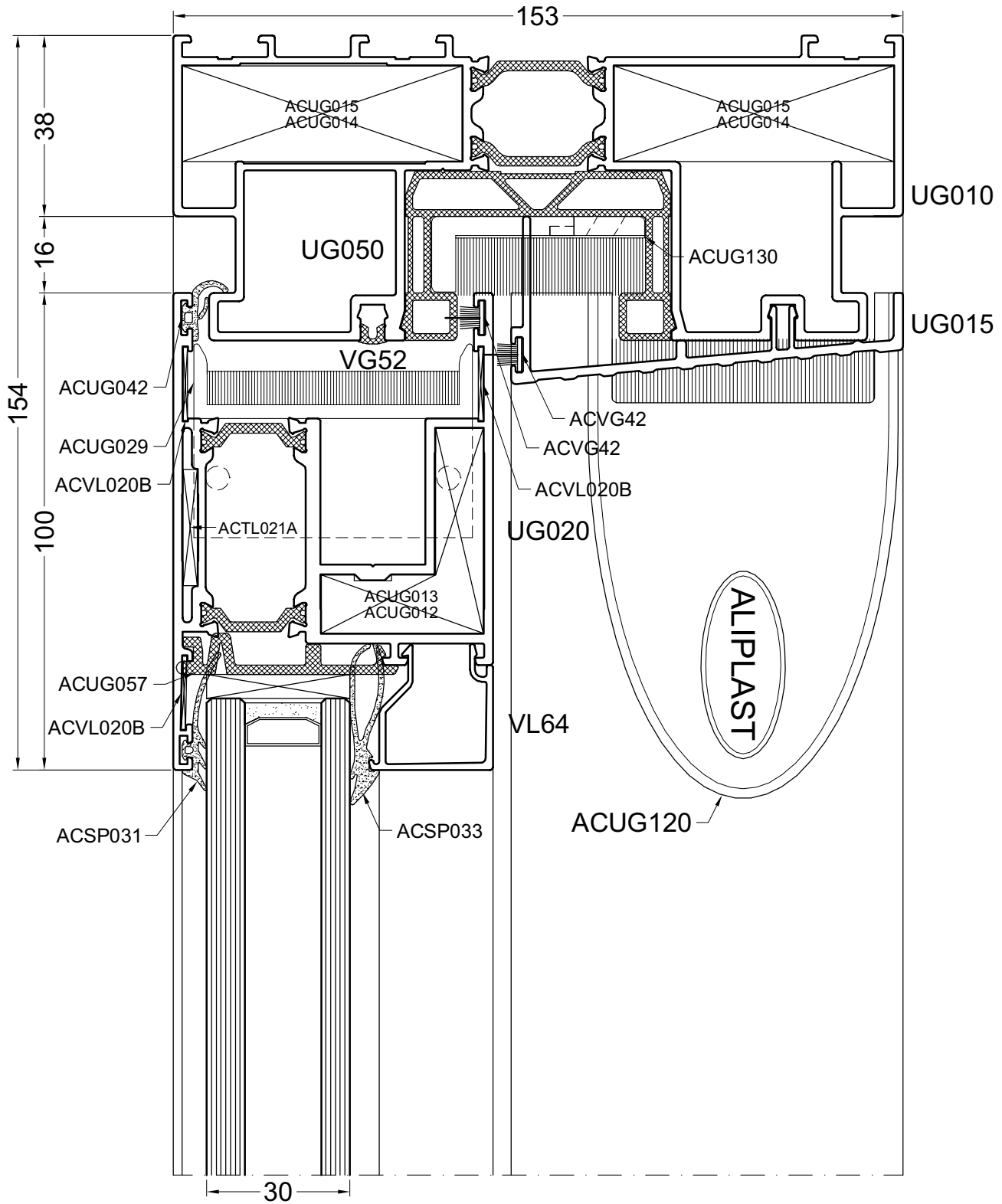

door112

112B

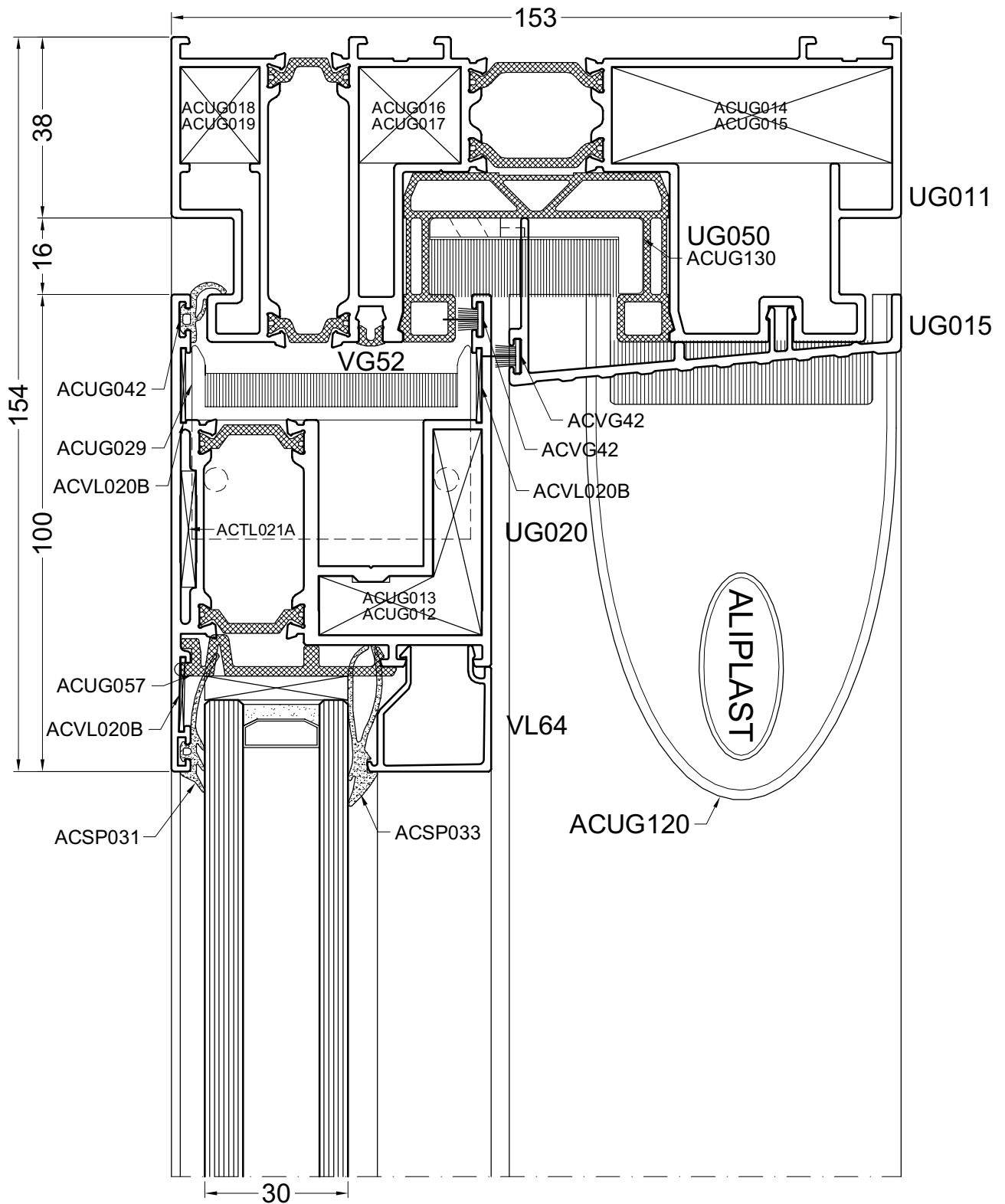

DOORSNEDE - COUPE - SCHNITT - SECTIONS

door112a



113A

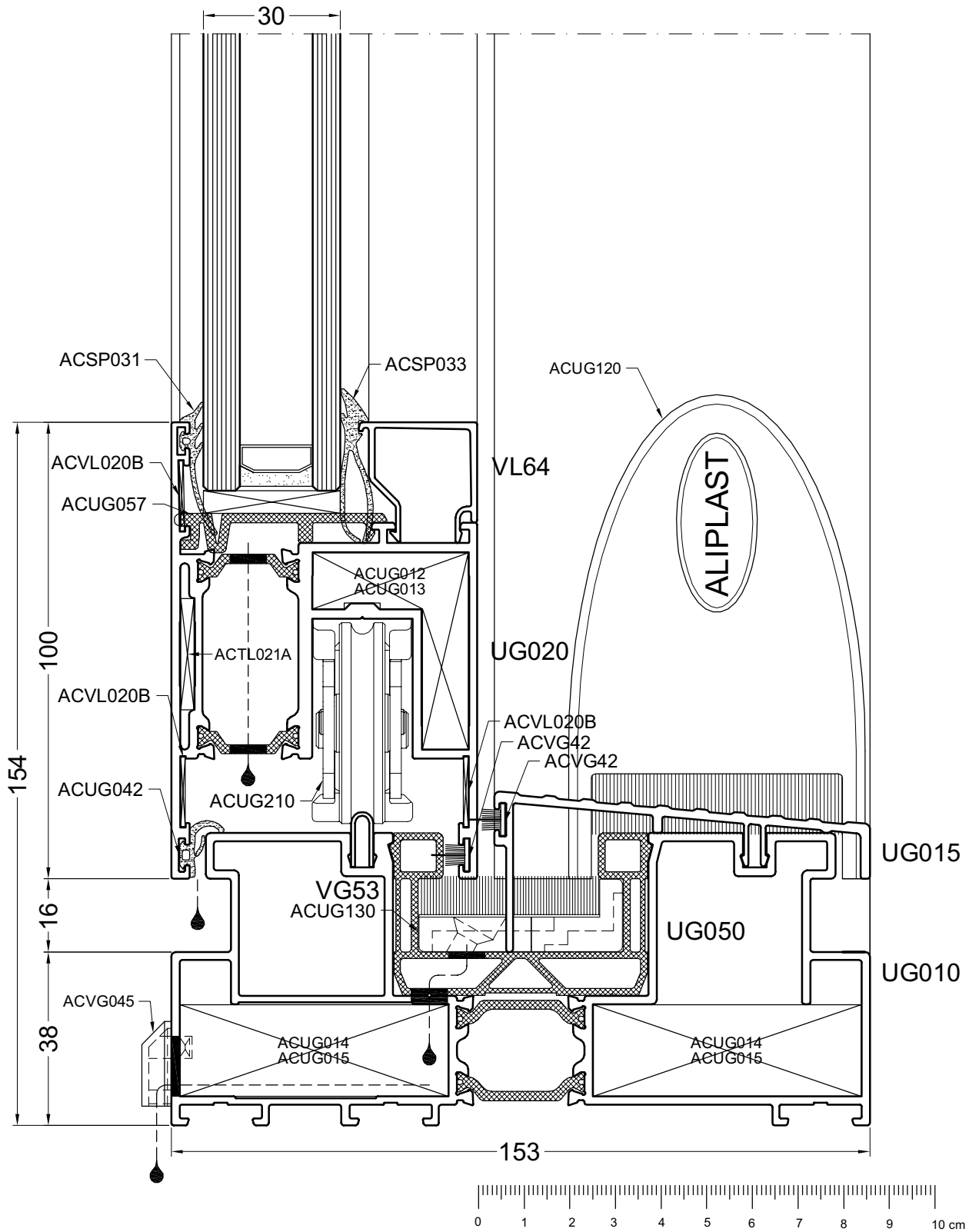

door113

113B

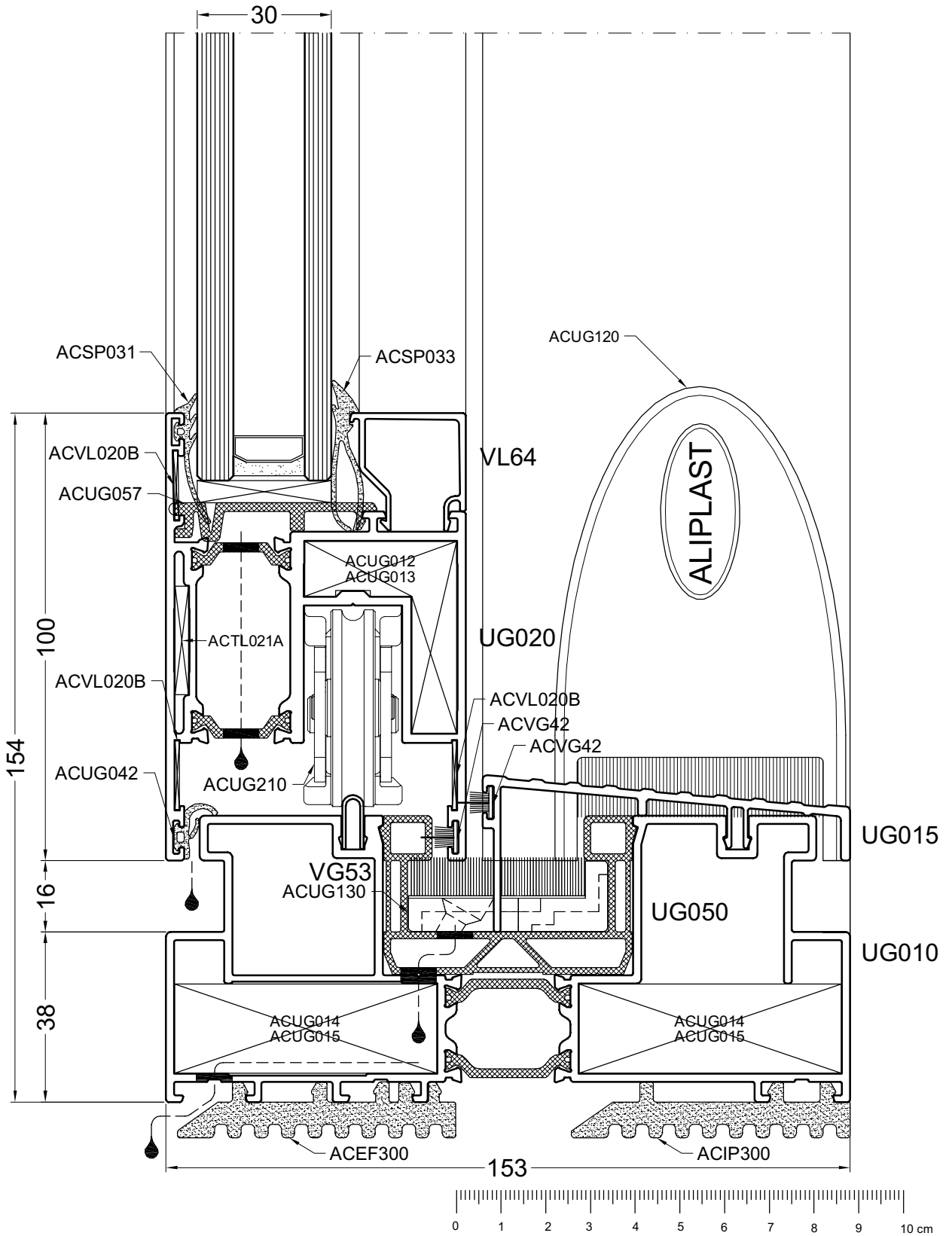

DOORSNEDE - COUPE - SCHNITT - SECTIONS

door113a

113C

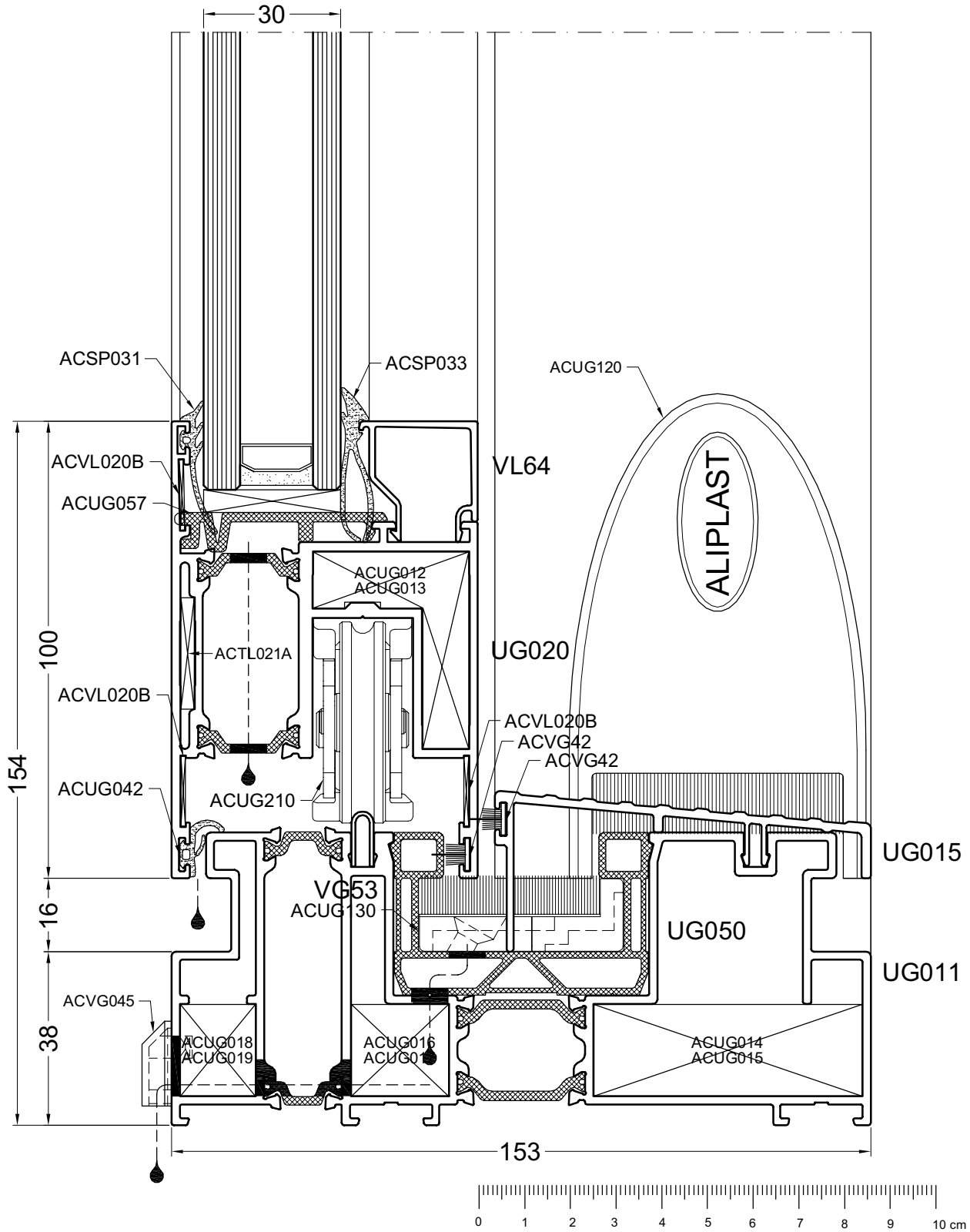

door113b

114A

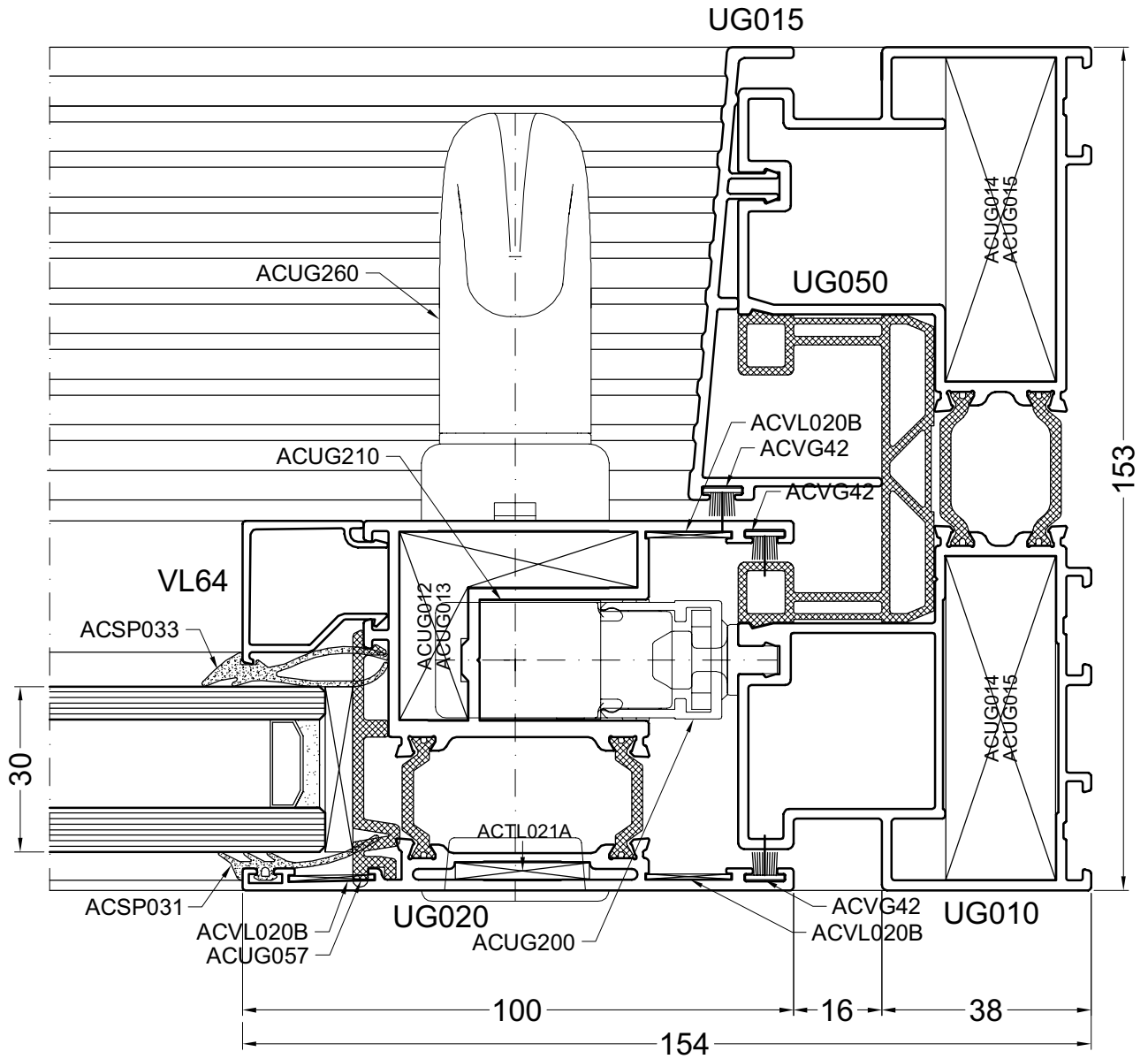

DOORSNEDE - COUPE - SCHNITT - SECTIONS

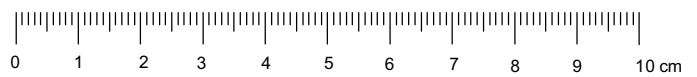

door114

114B

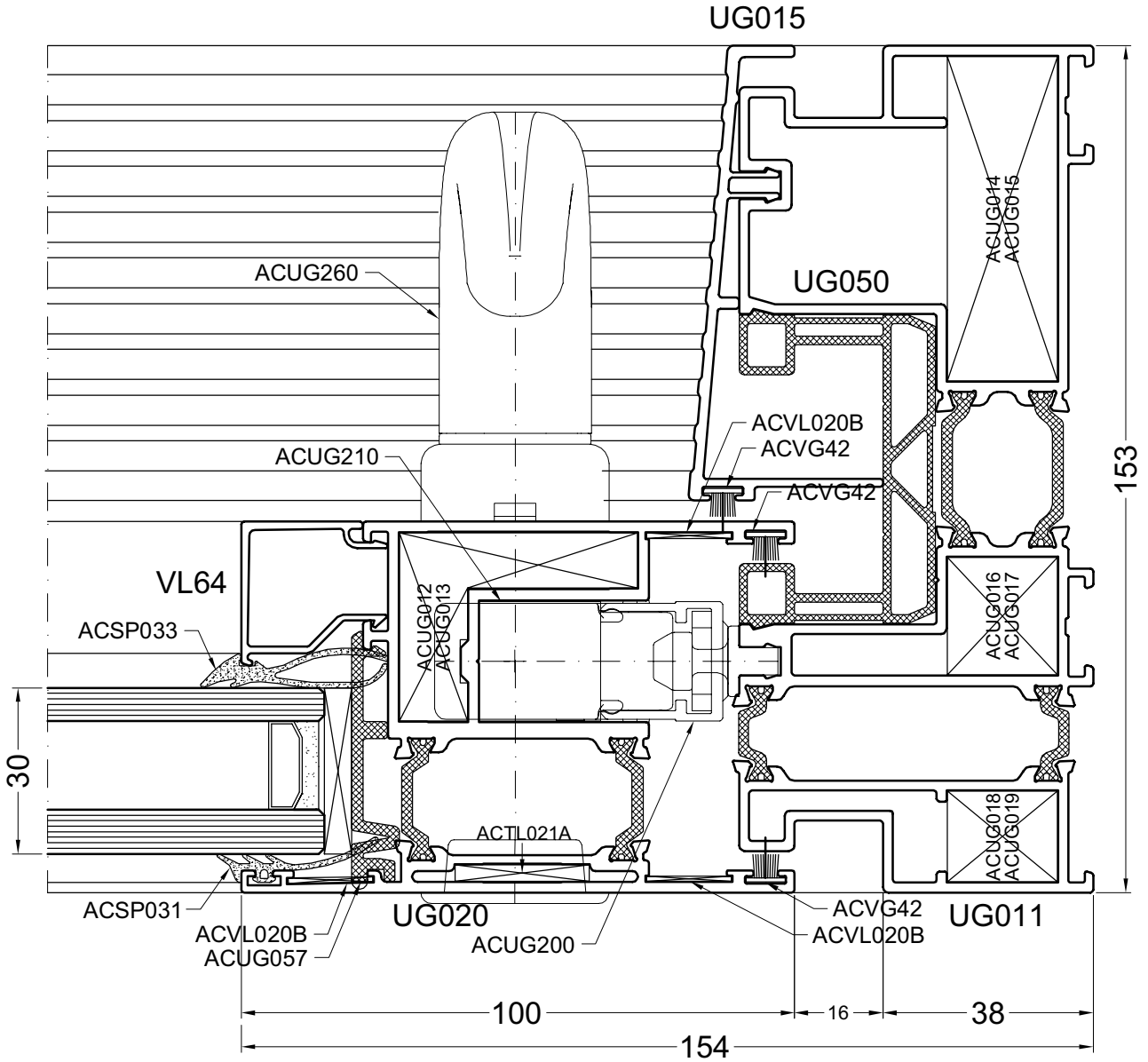

door114a

115A

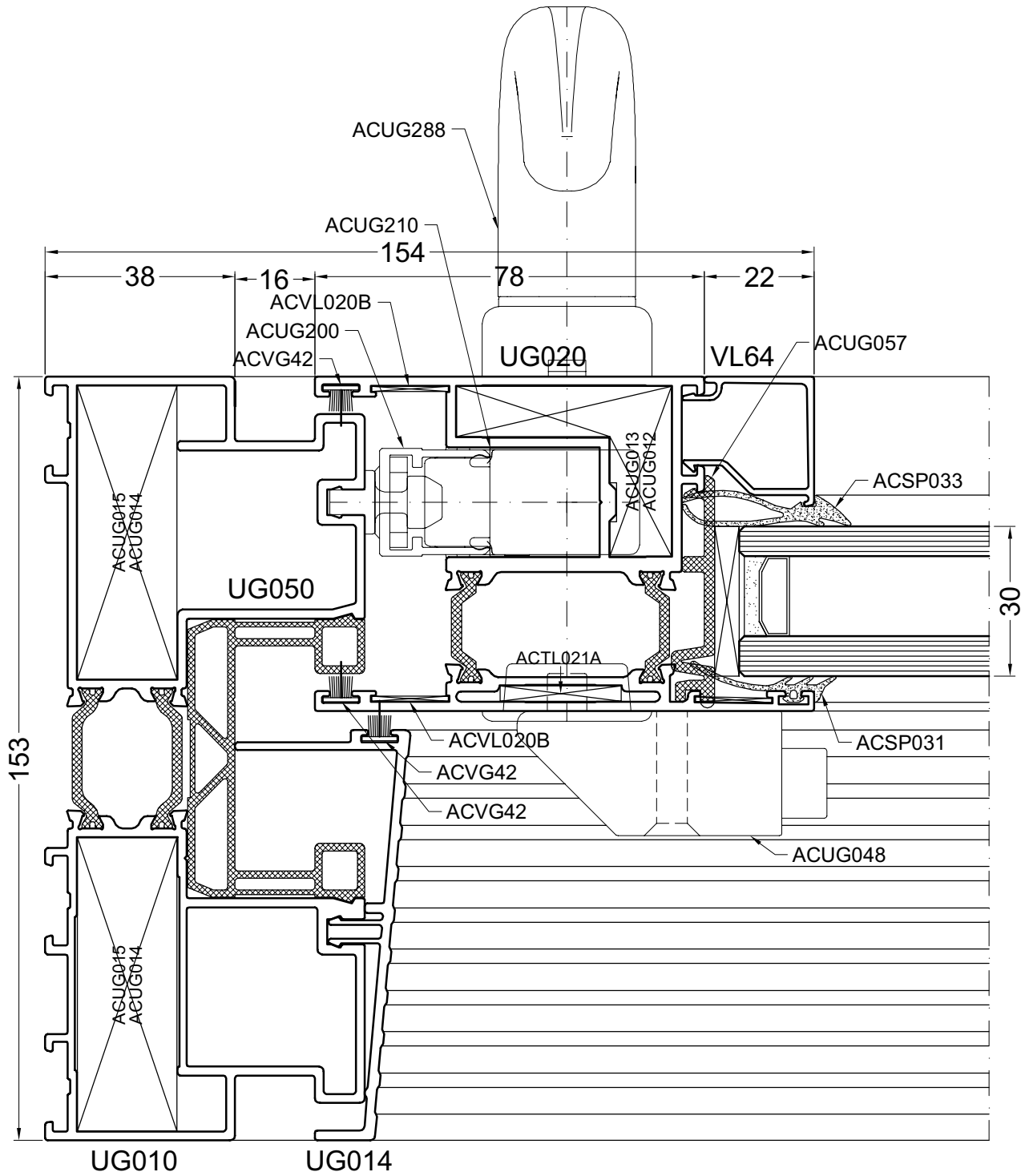

DOORSNEDE - COUPE - SCHNITT - SECTIONS

door115

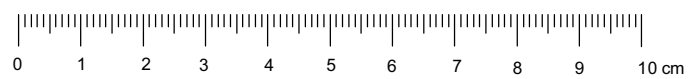

115B

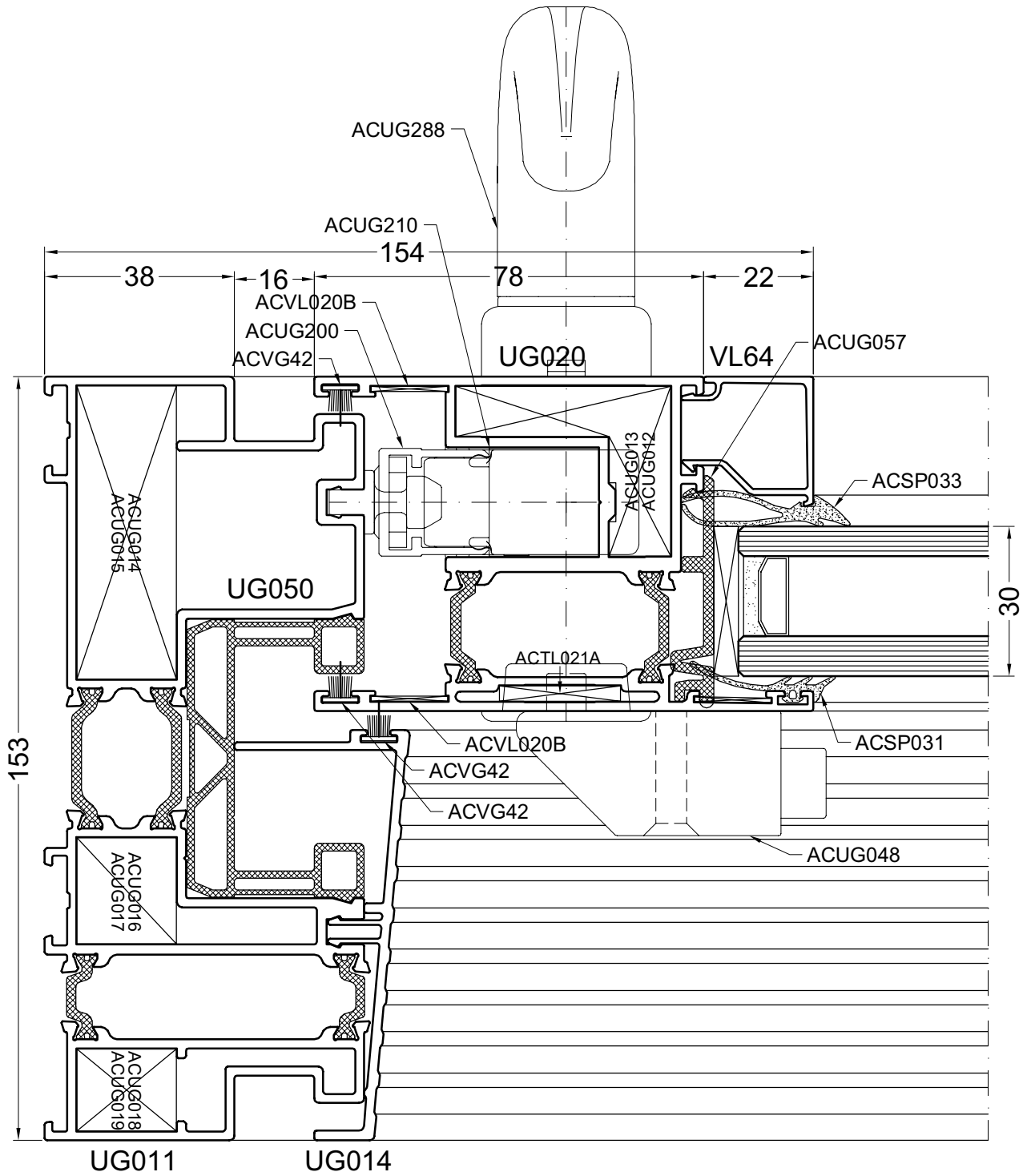

door115a

116A

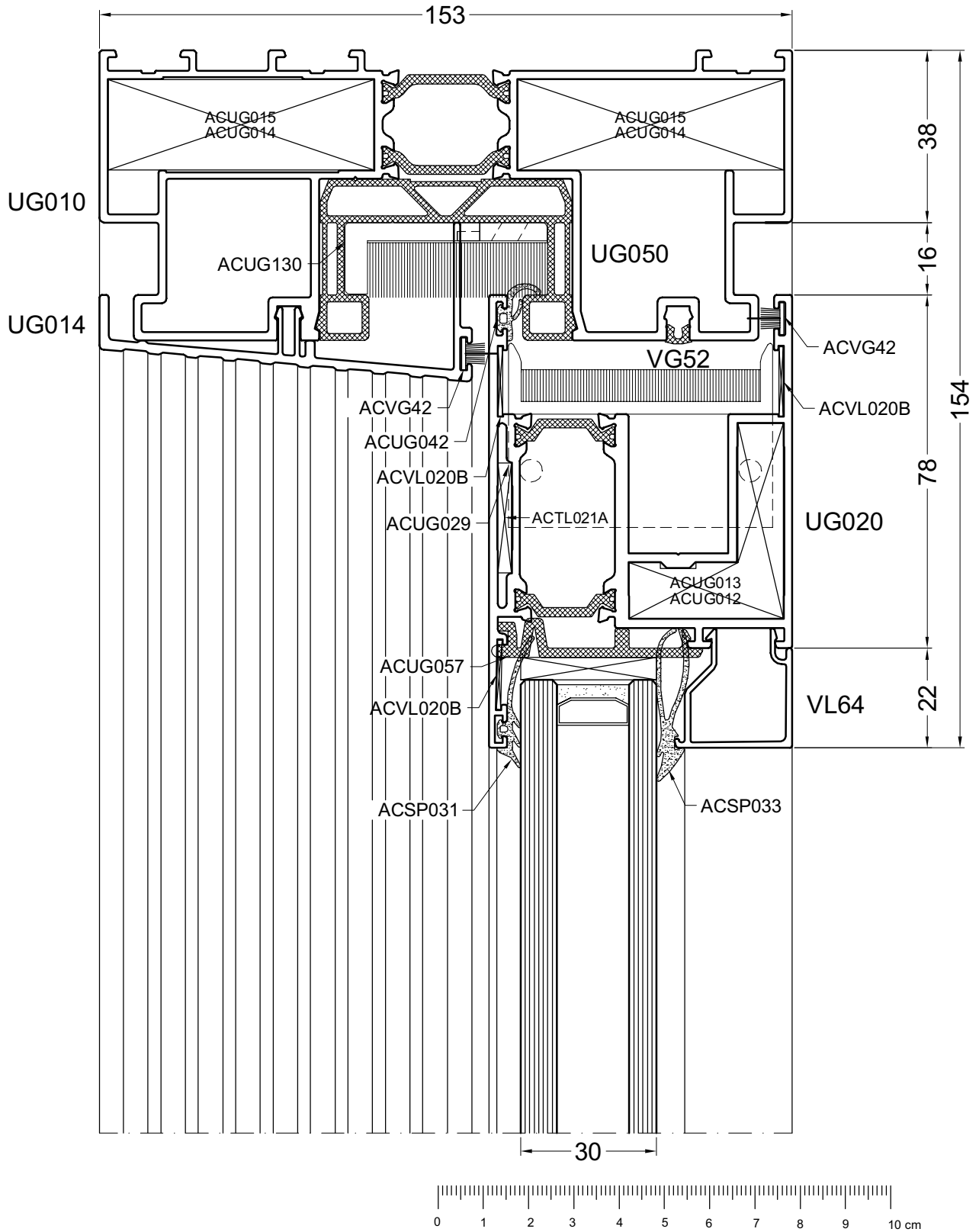

DOORSNEDE - COUPE - SCHNITT - SECTIONS

door116

116B

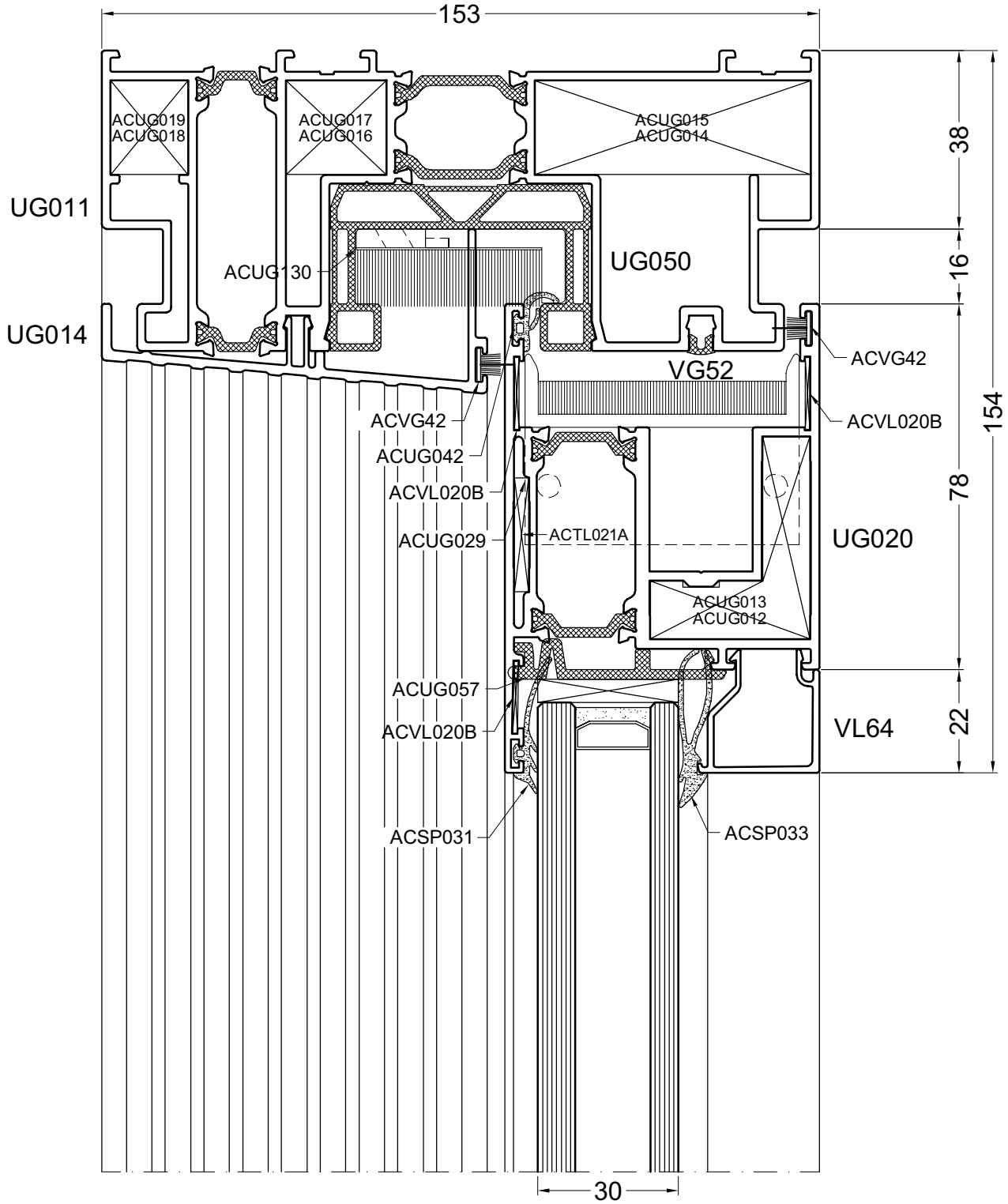

door116a

117A

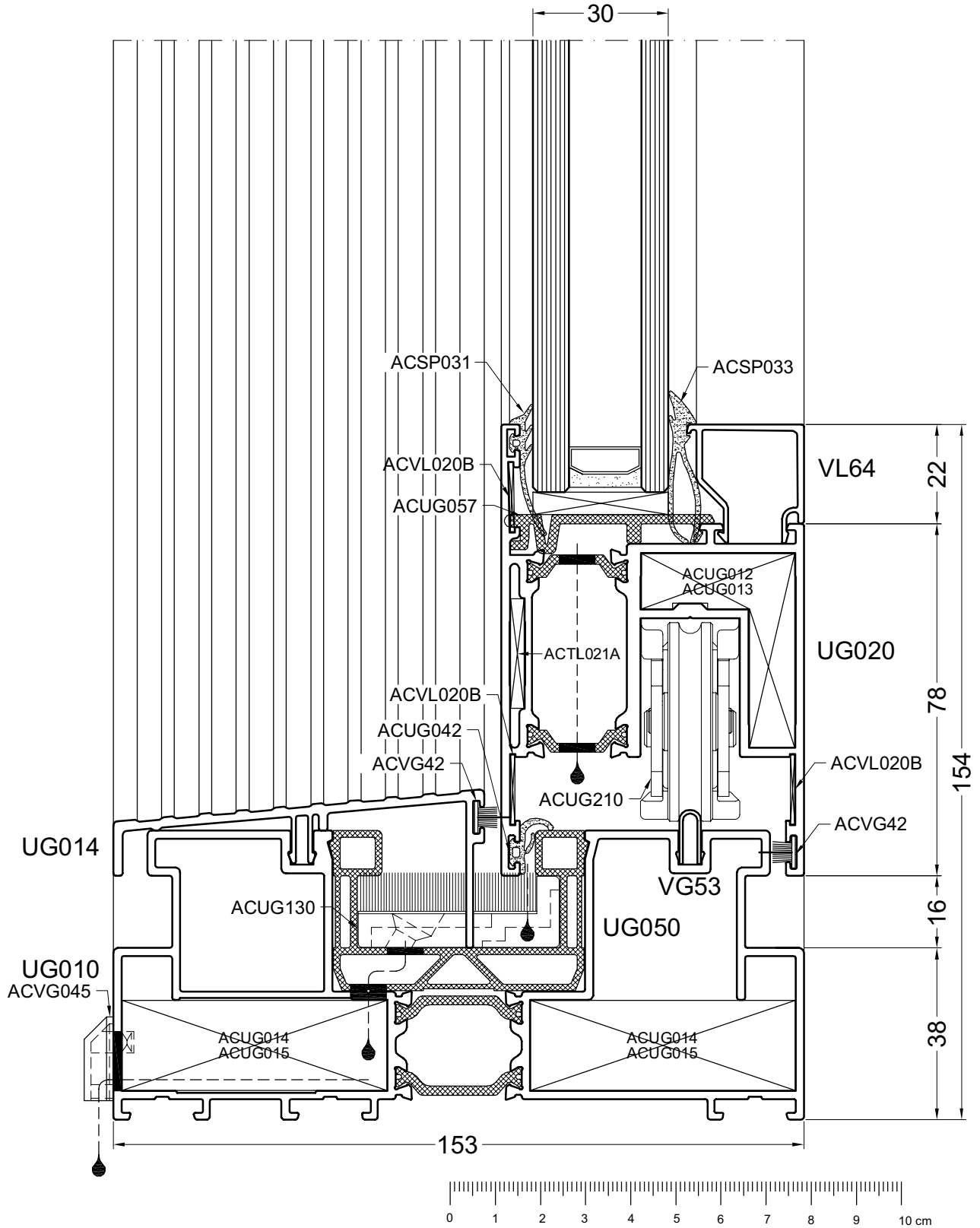

DOORSNEDE - COUPE - SCHNITT - SECTIONS

door117

117B

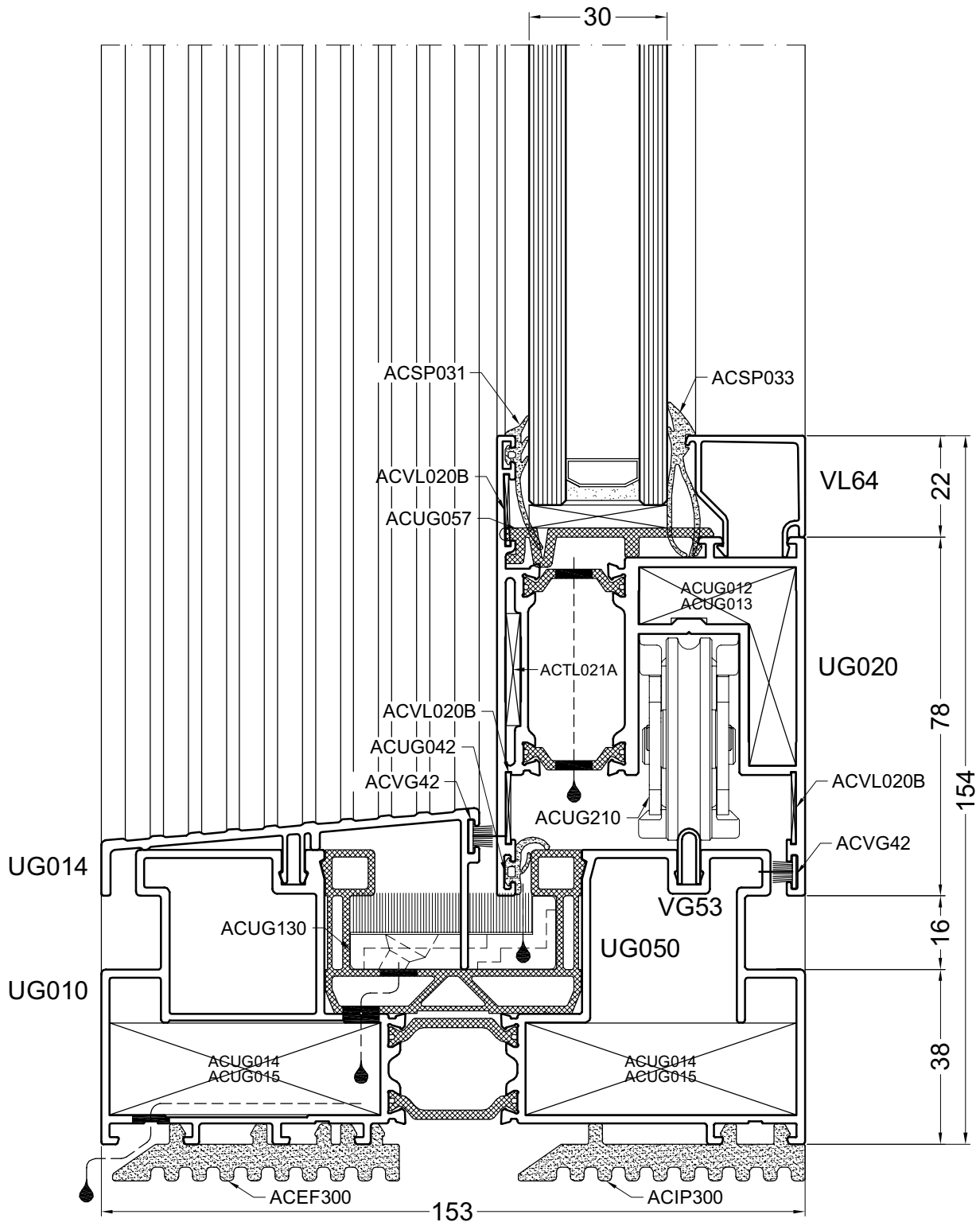

door117a

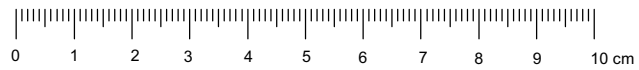

117C

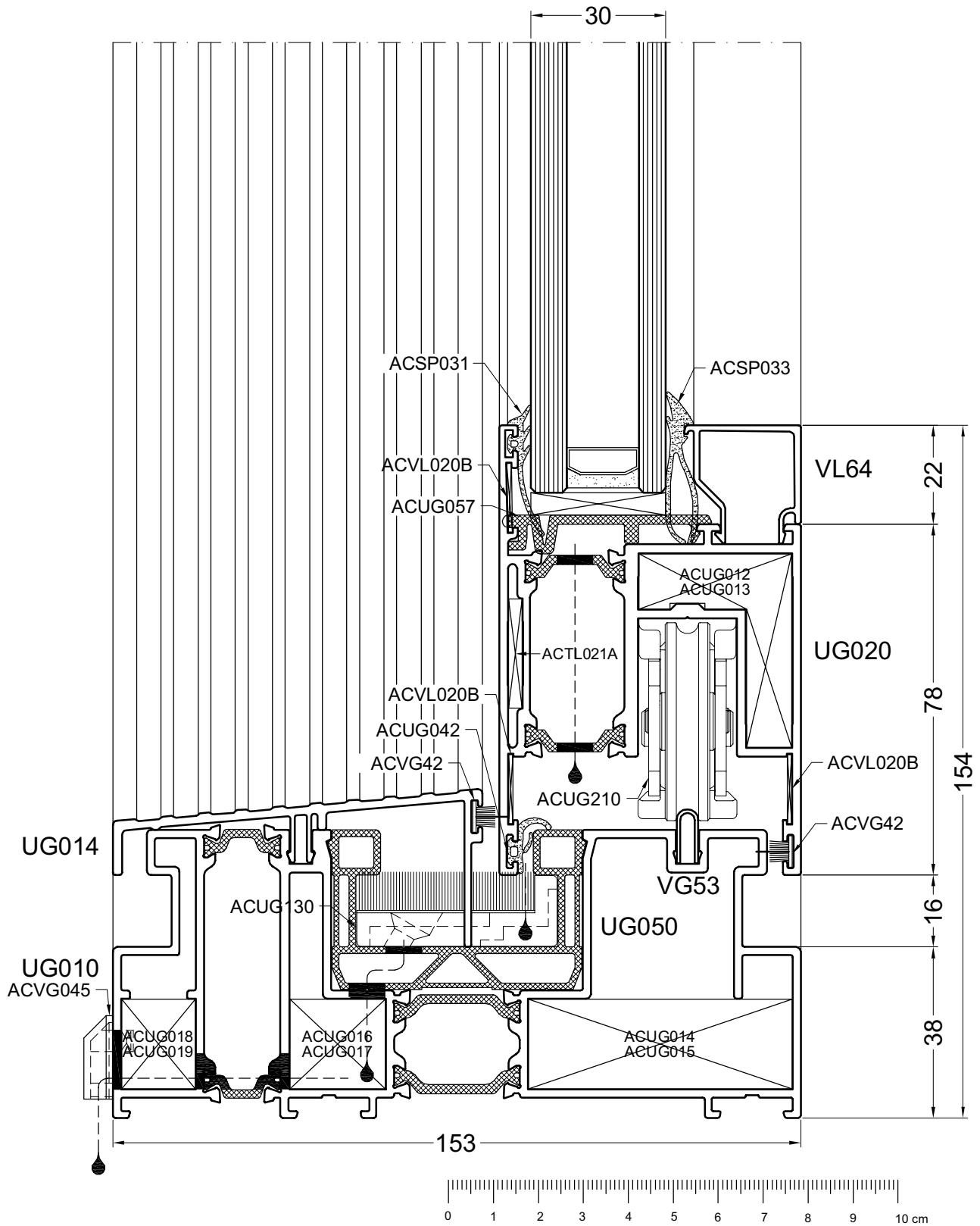

DOORSNEDE - COUPE - SCHNITT - SECTIONS

door117b

118A

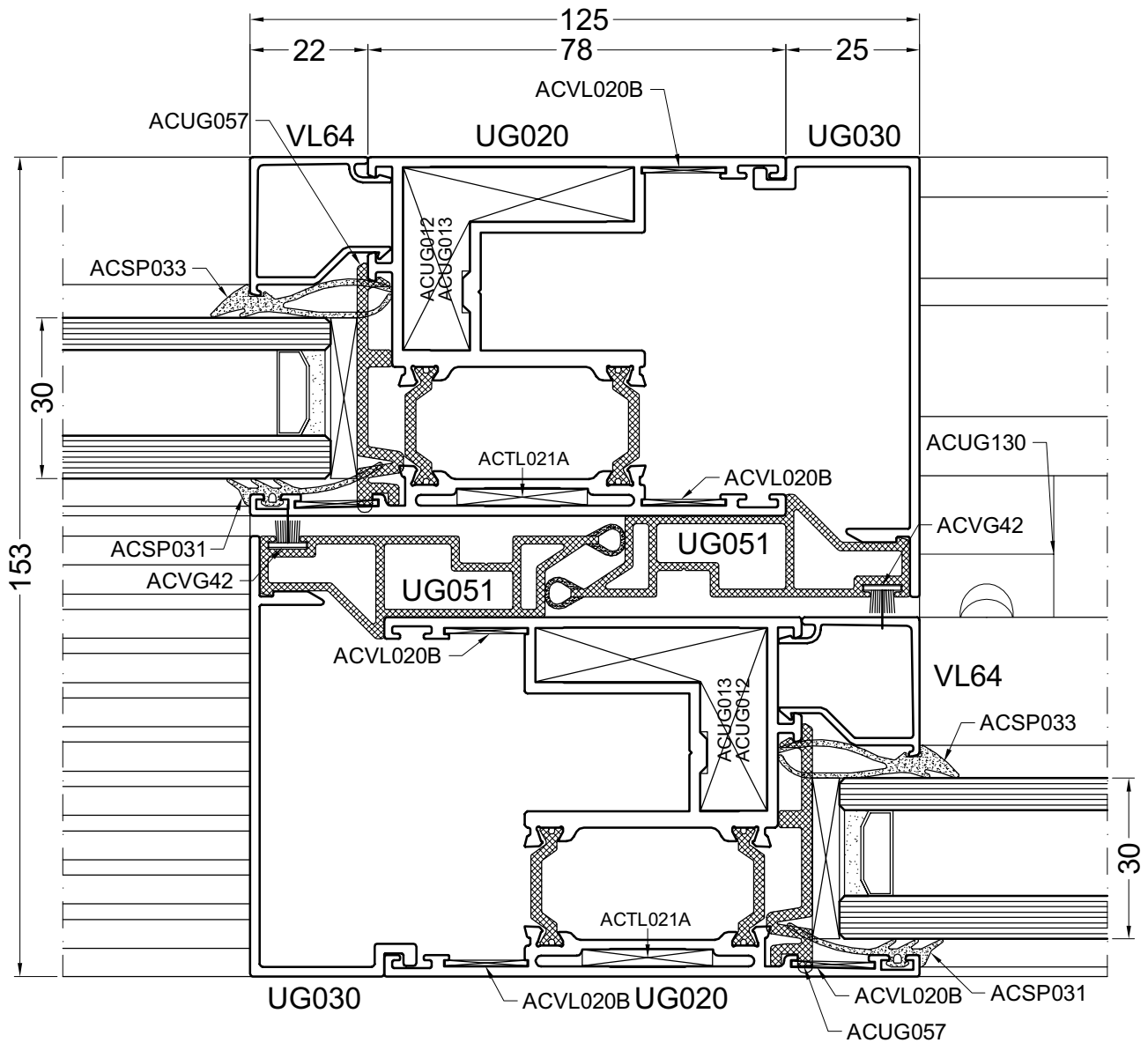

door118

118B

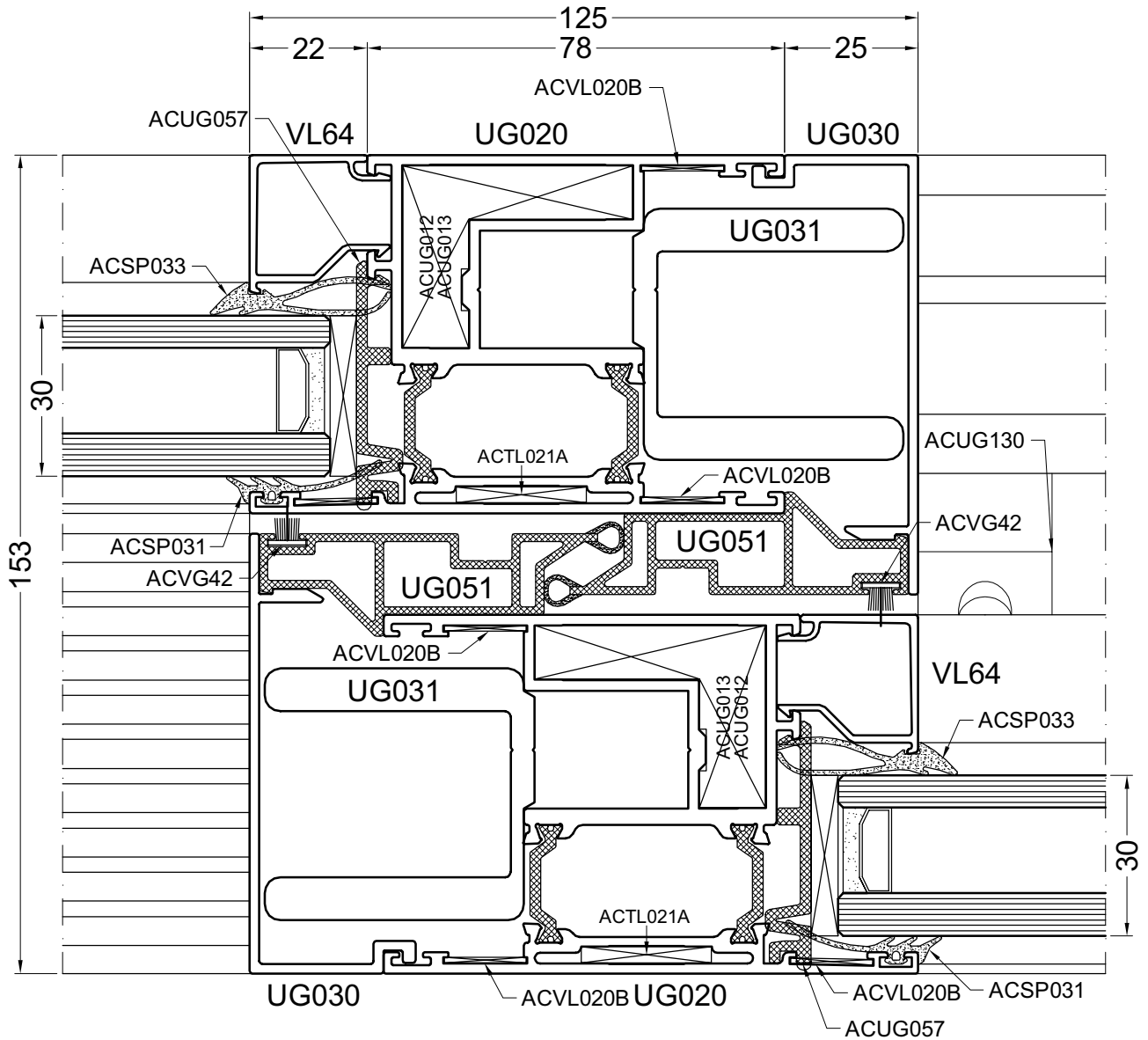

door118a



119A

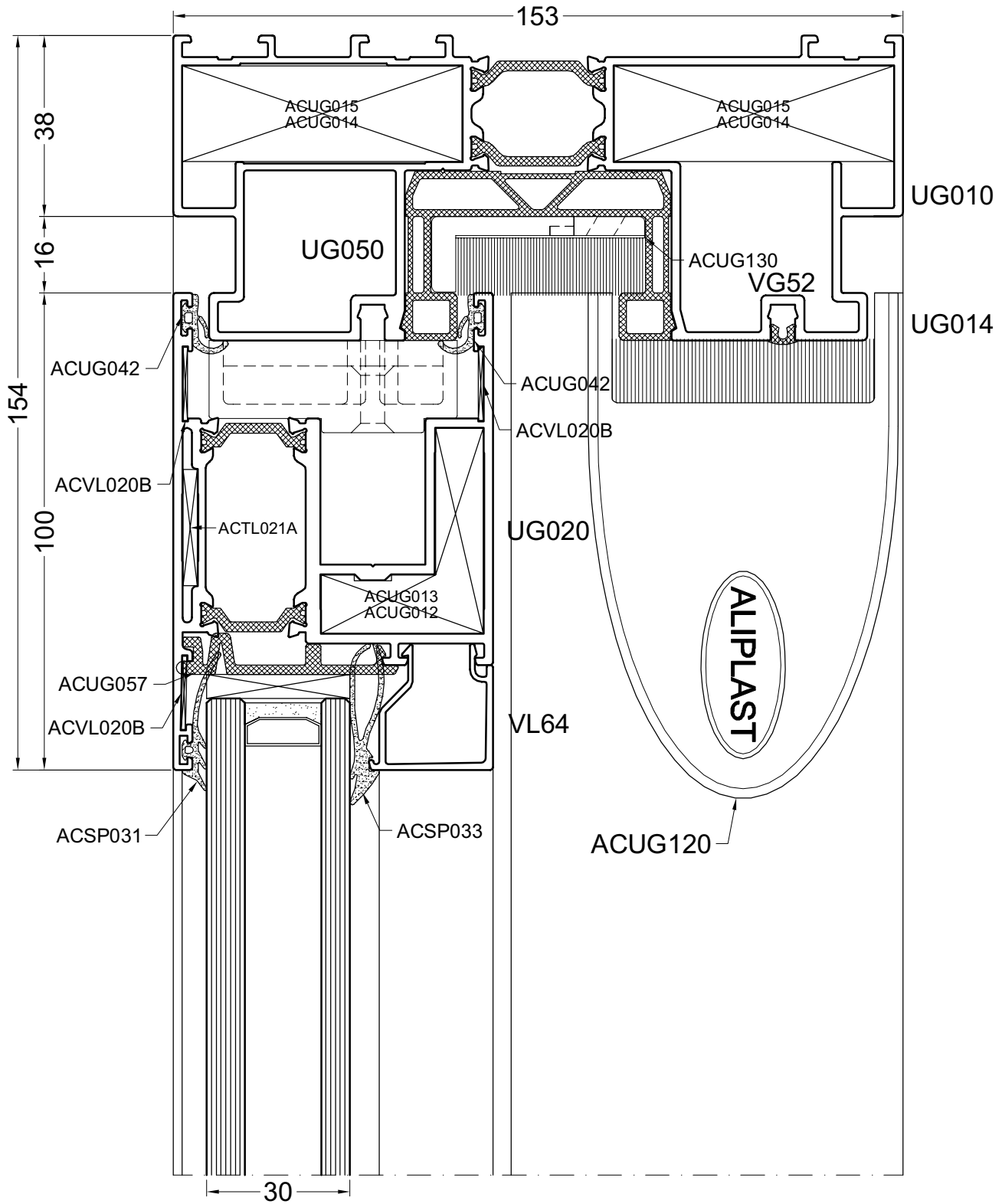

door119

119B

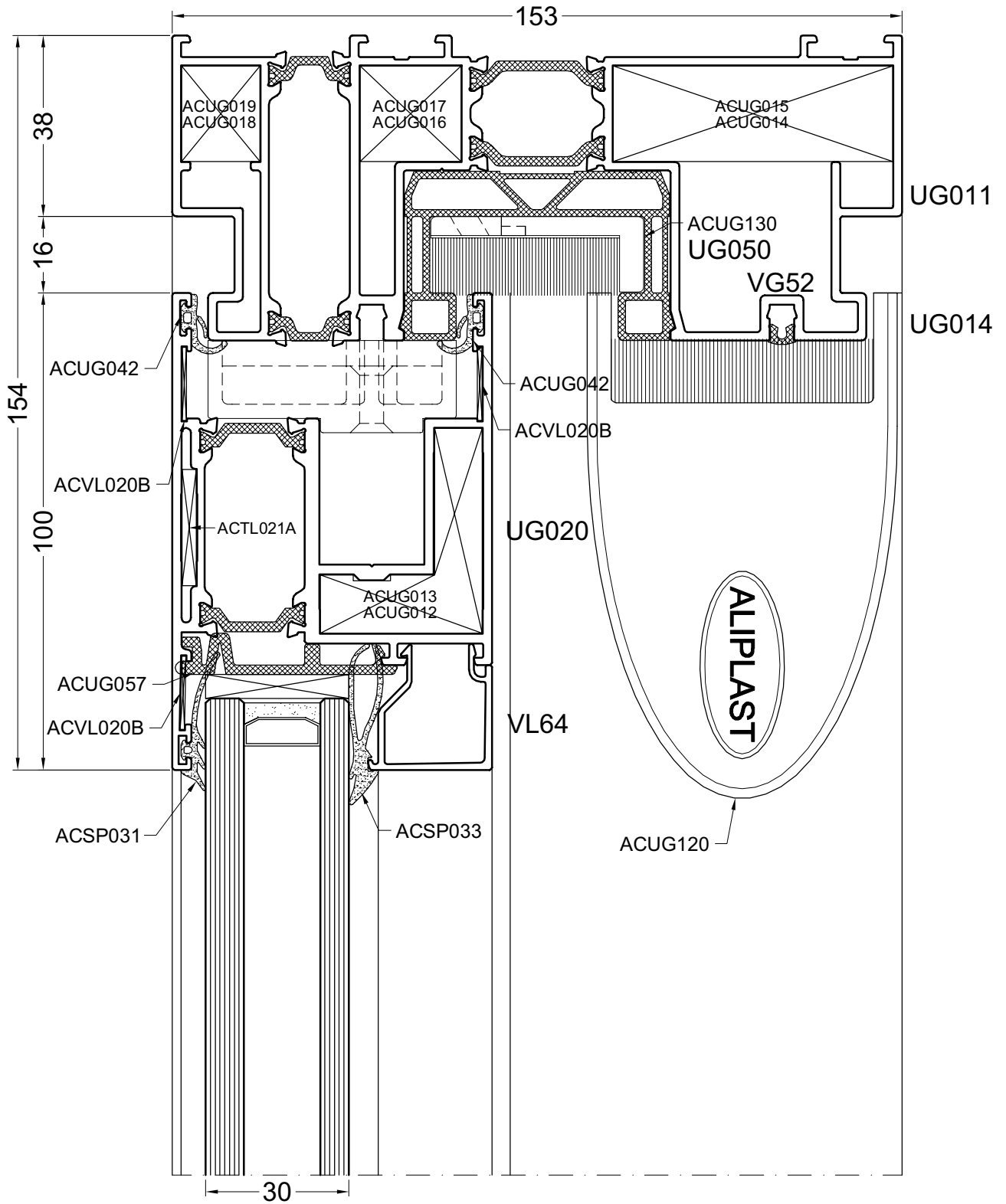

DOORSNEDE - COUPE - SCHNITT - SECTIONS

door119a

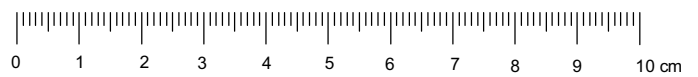

120A

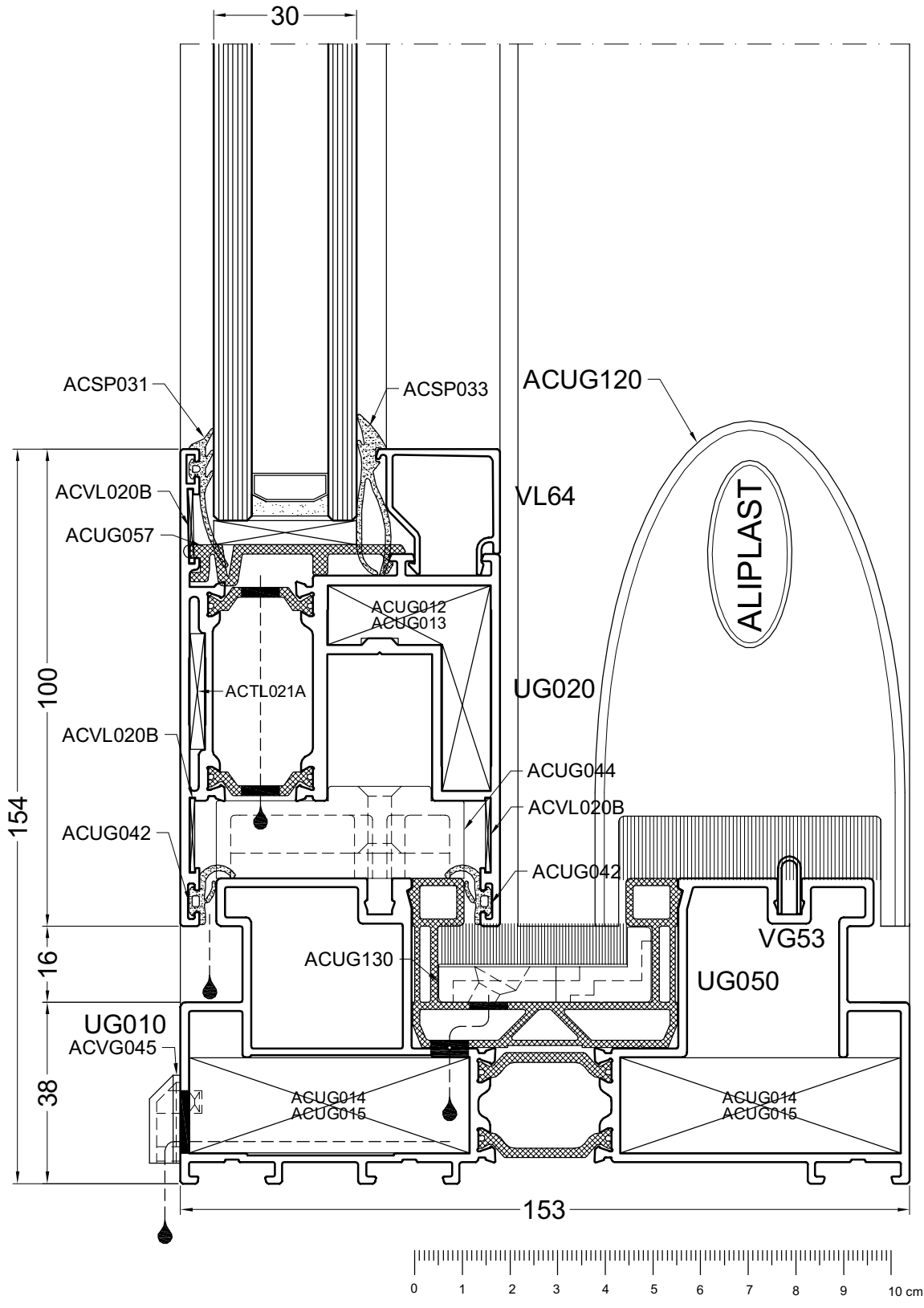

door120

120B

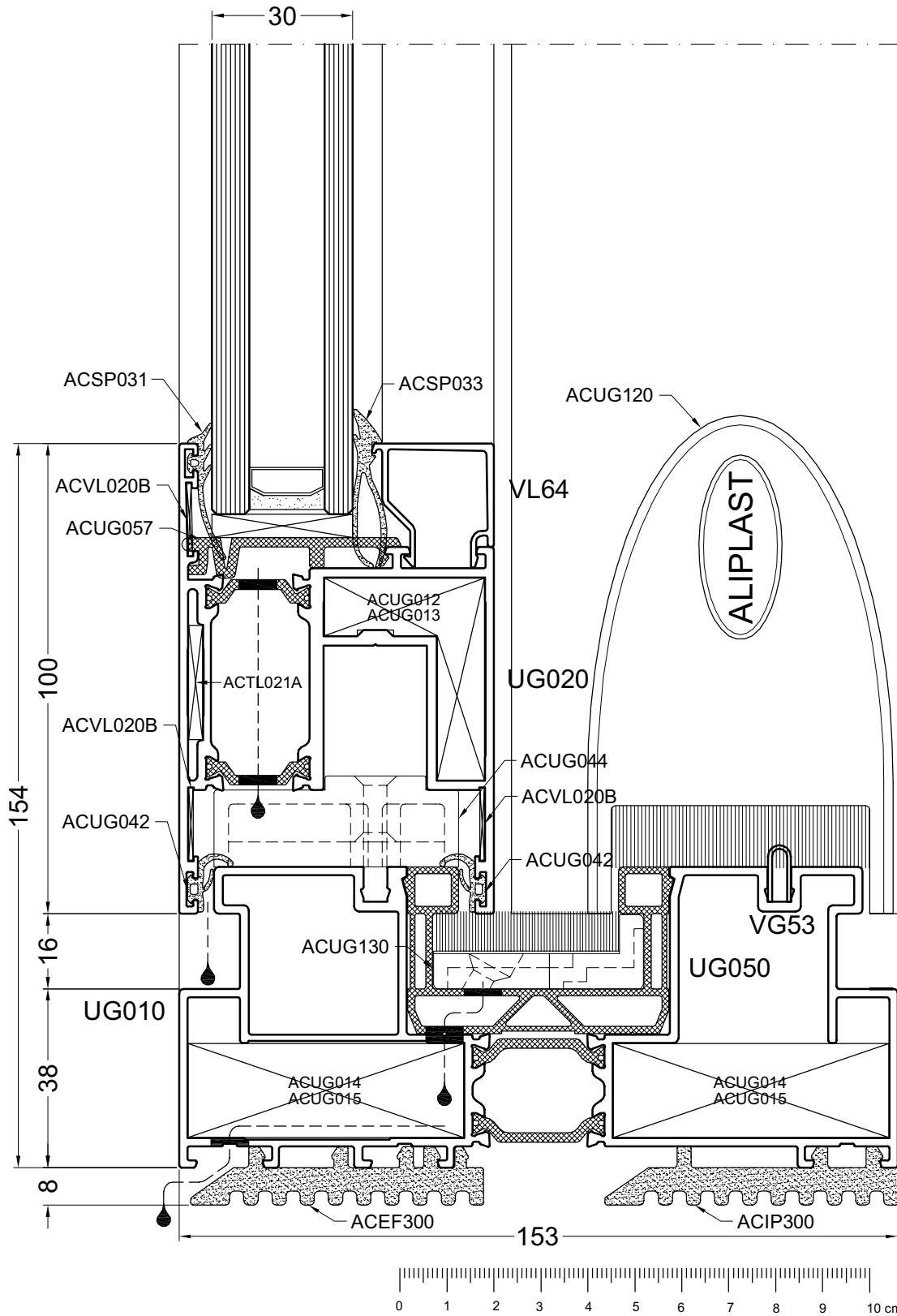

DOORSNEDE - COUPE - SCHNITT - SECTIONS

door120a

120C

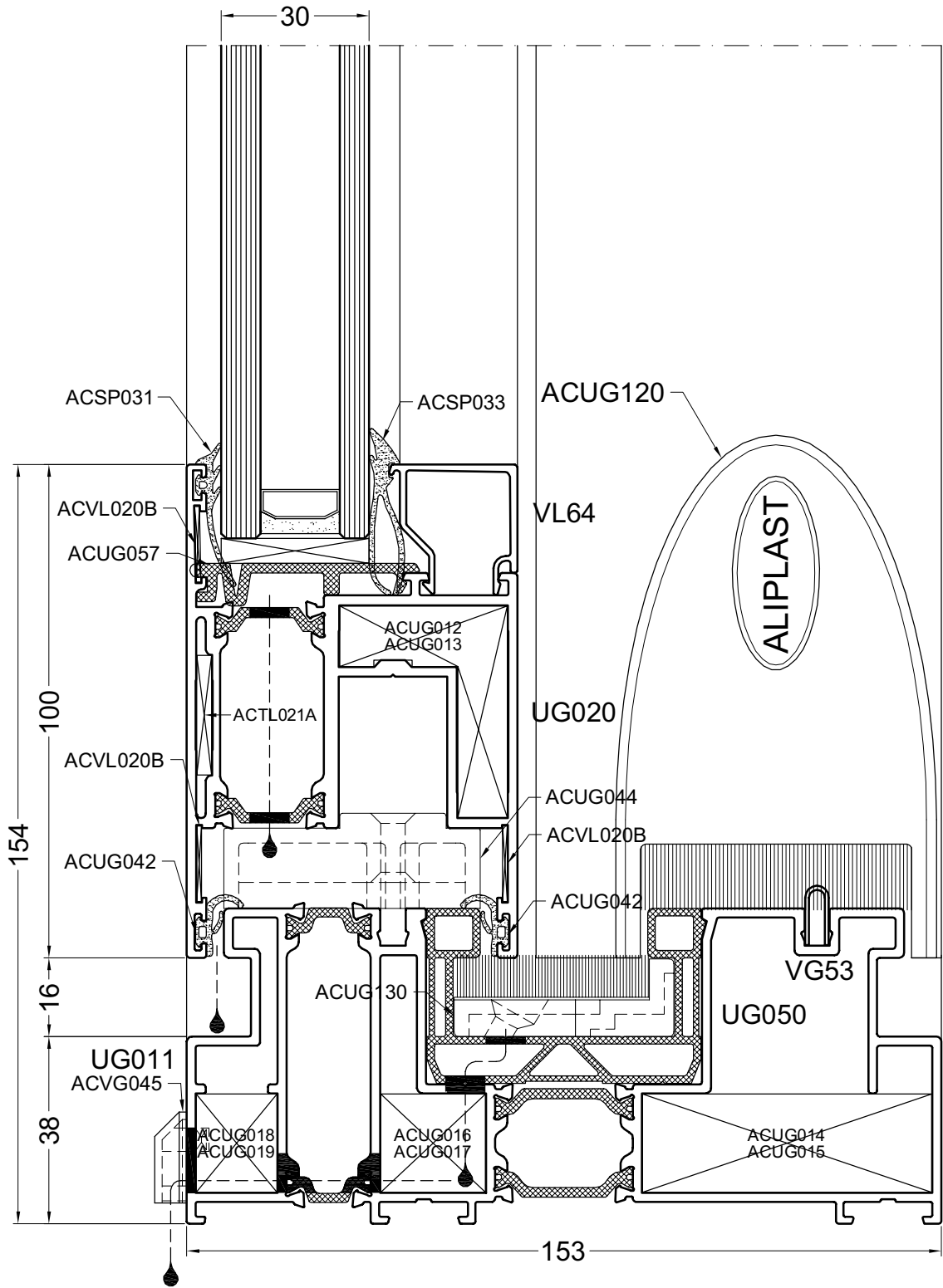

door120b

121A

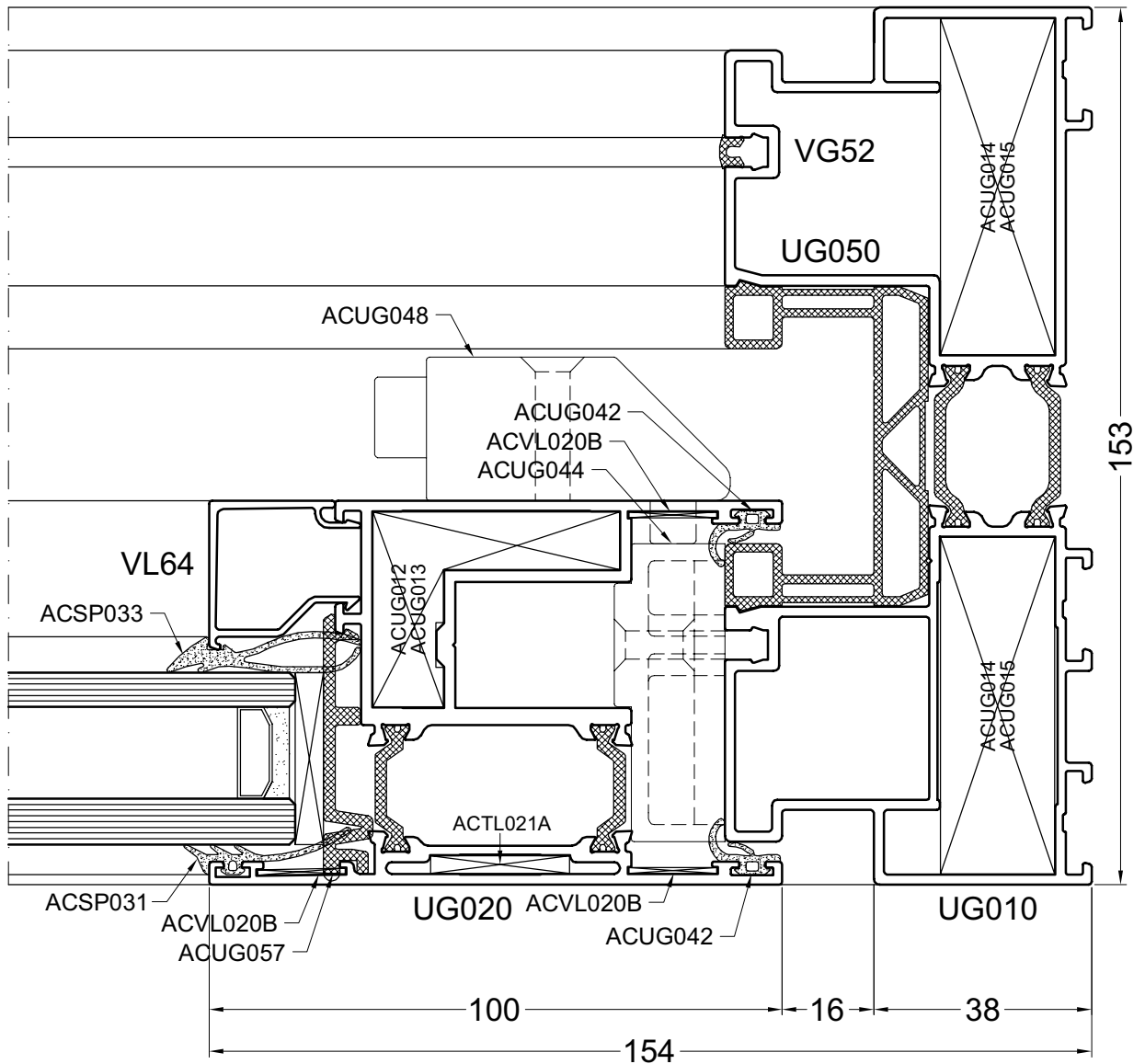

DOORSNEDE - COUPE - SCHNITT - SECTIONS

door121



121B

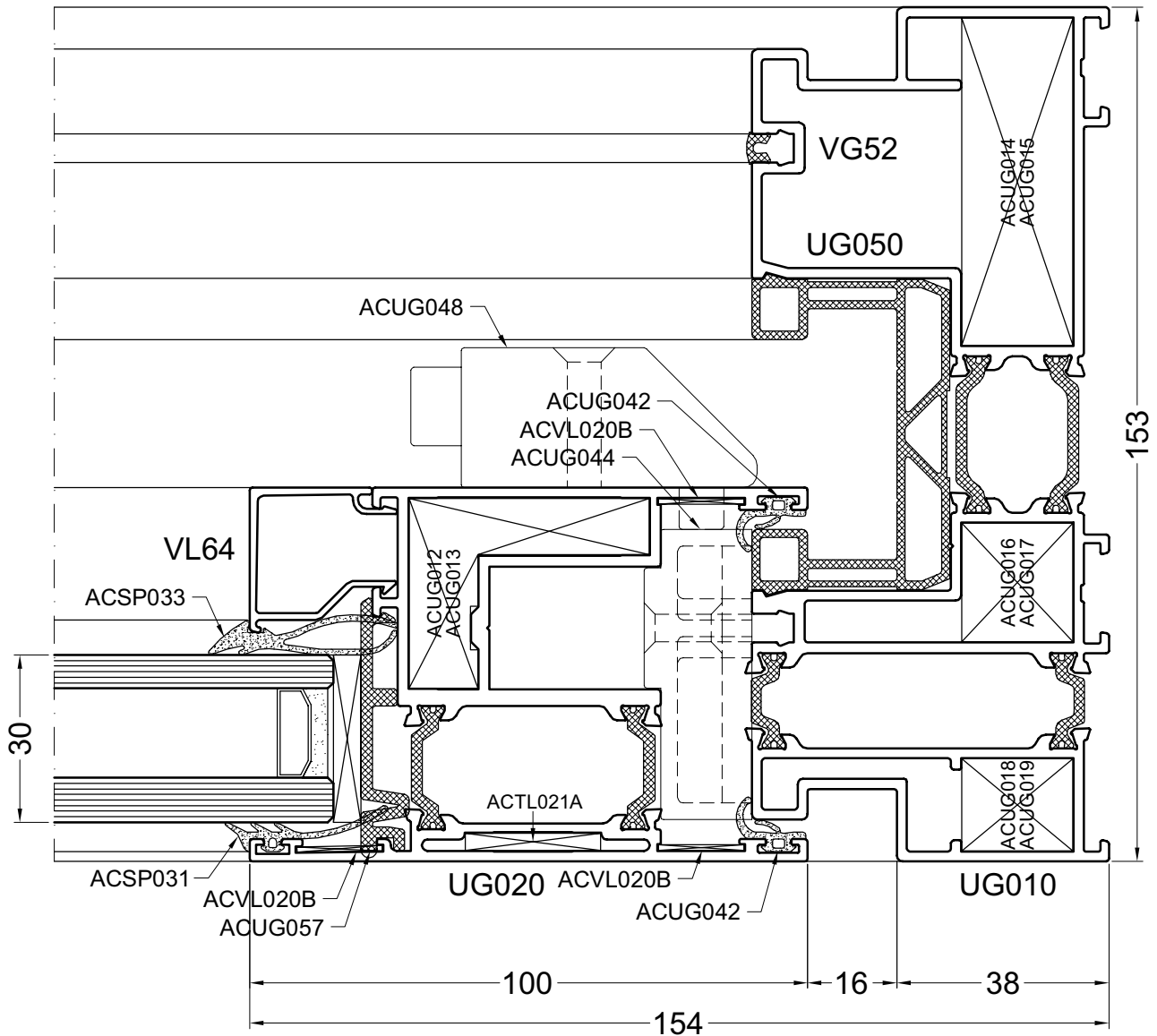

door121a

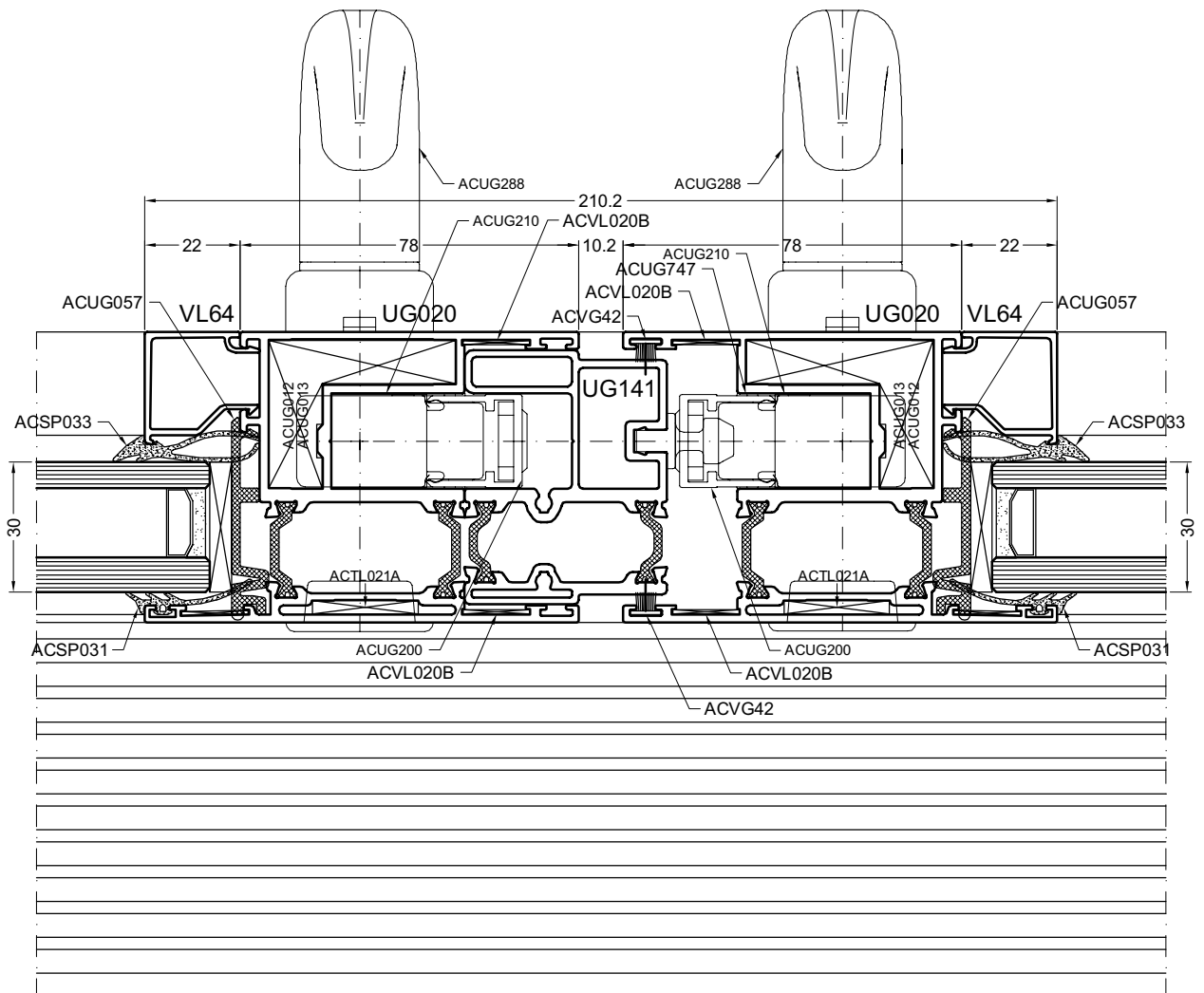

door122

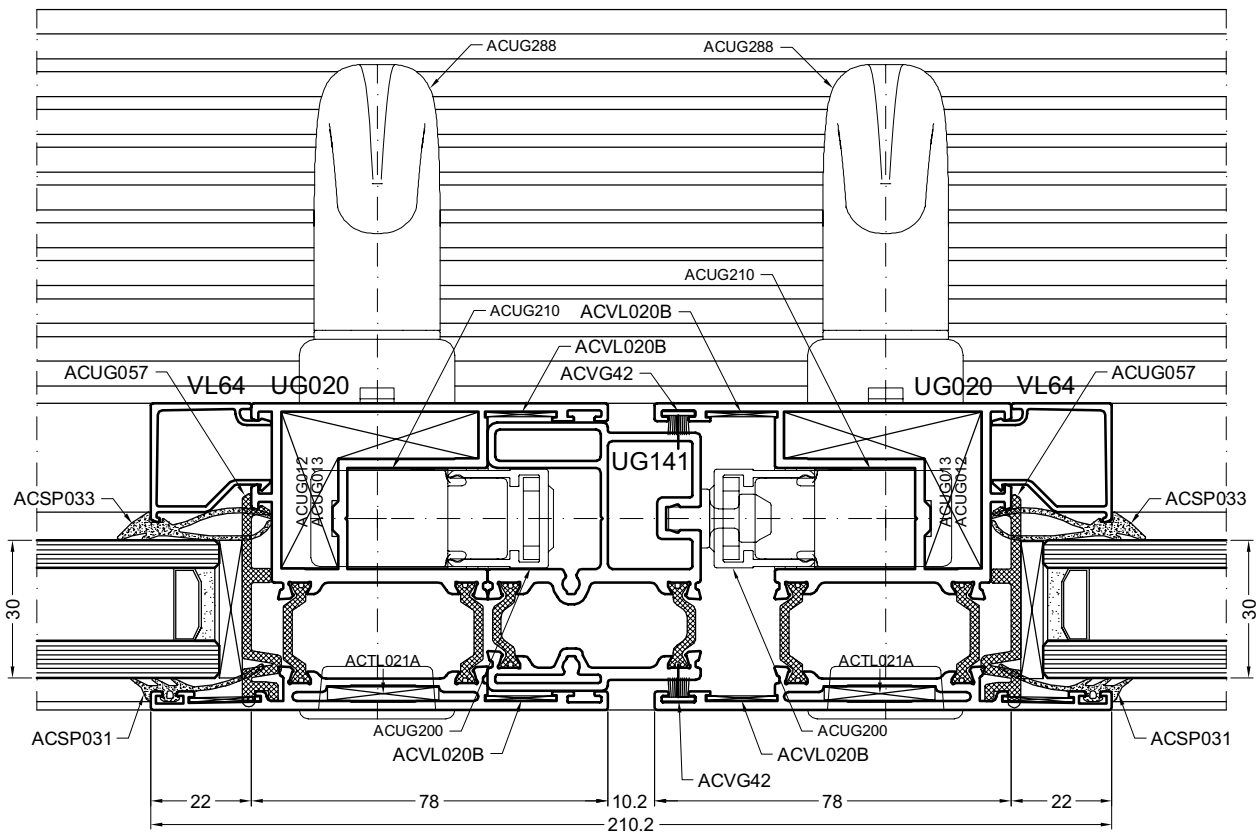

door123

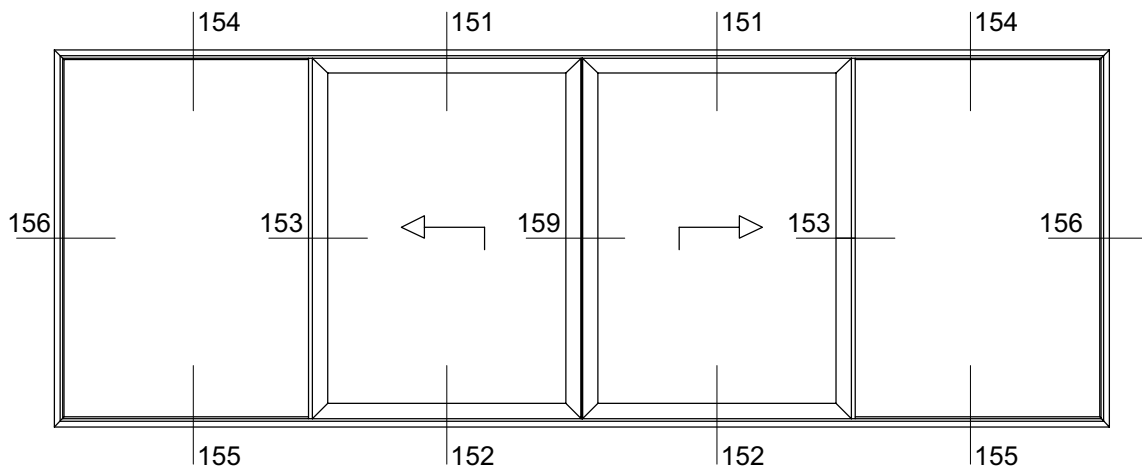
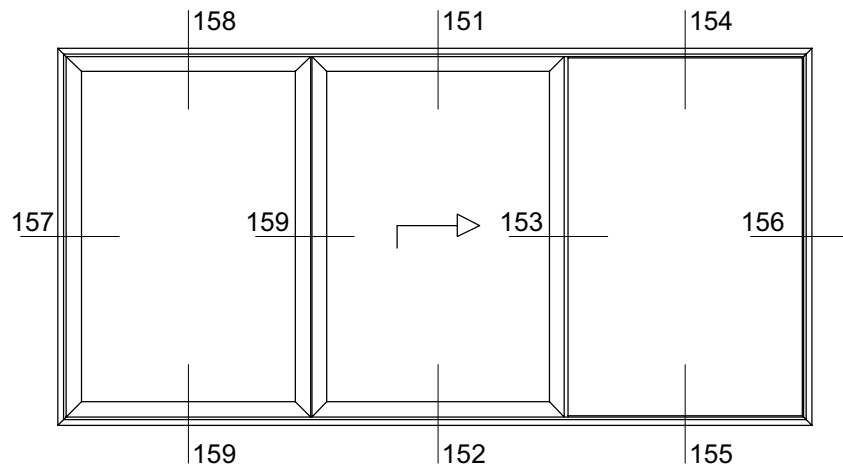
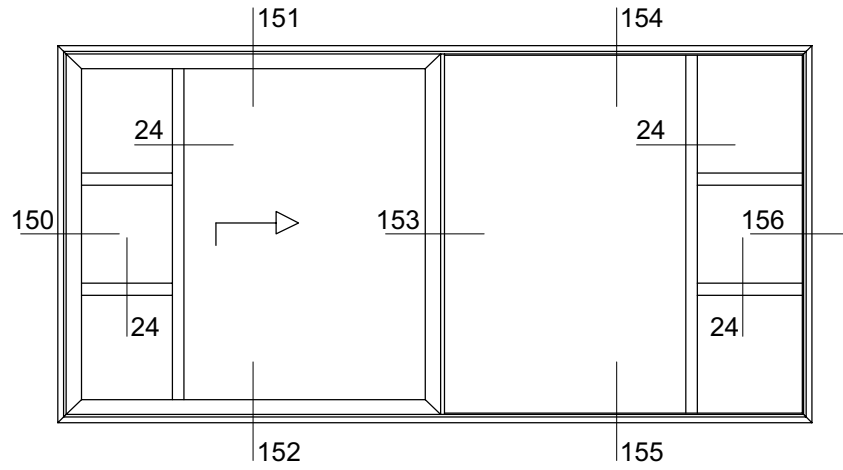

type15

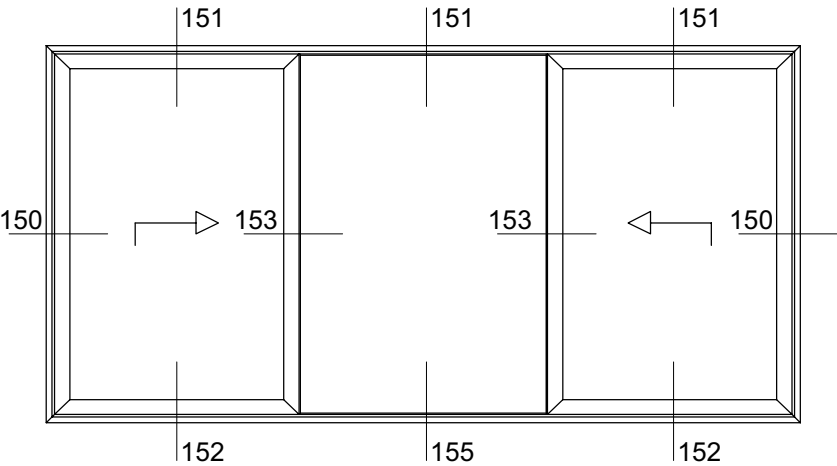

type16

150

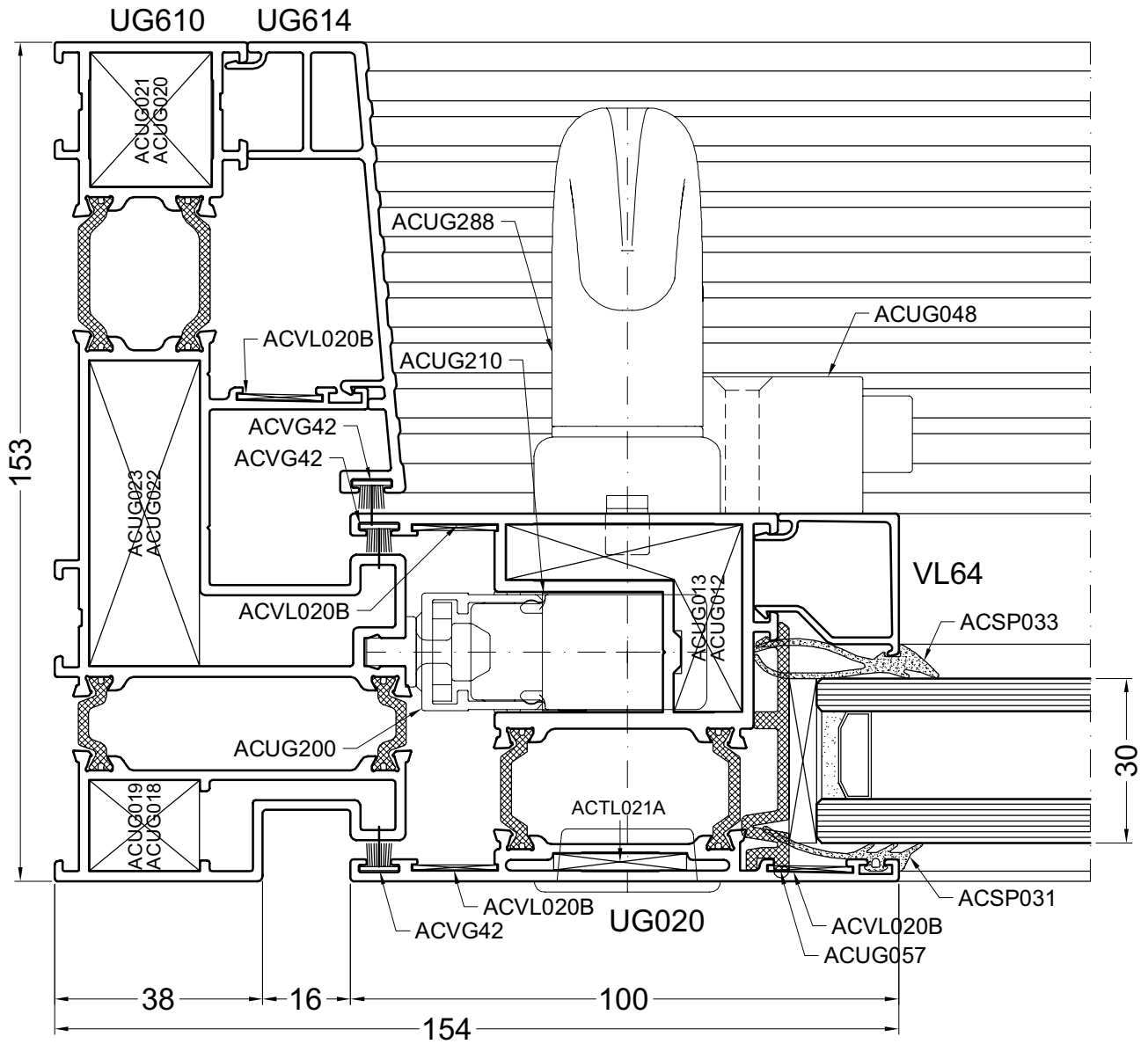

DOORSNEDE - COUPE - SCHNITT - SECTIONS



door150

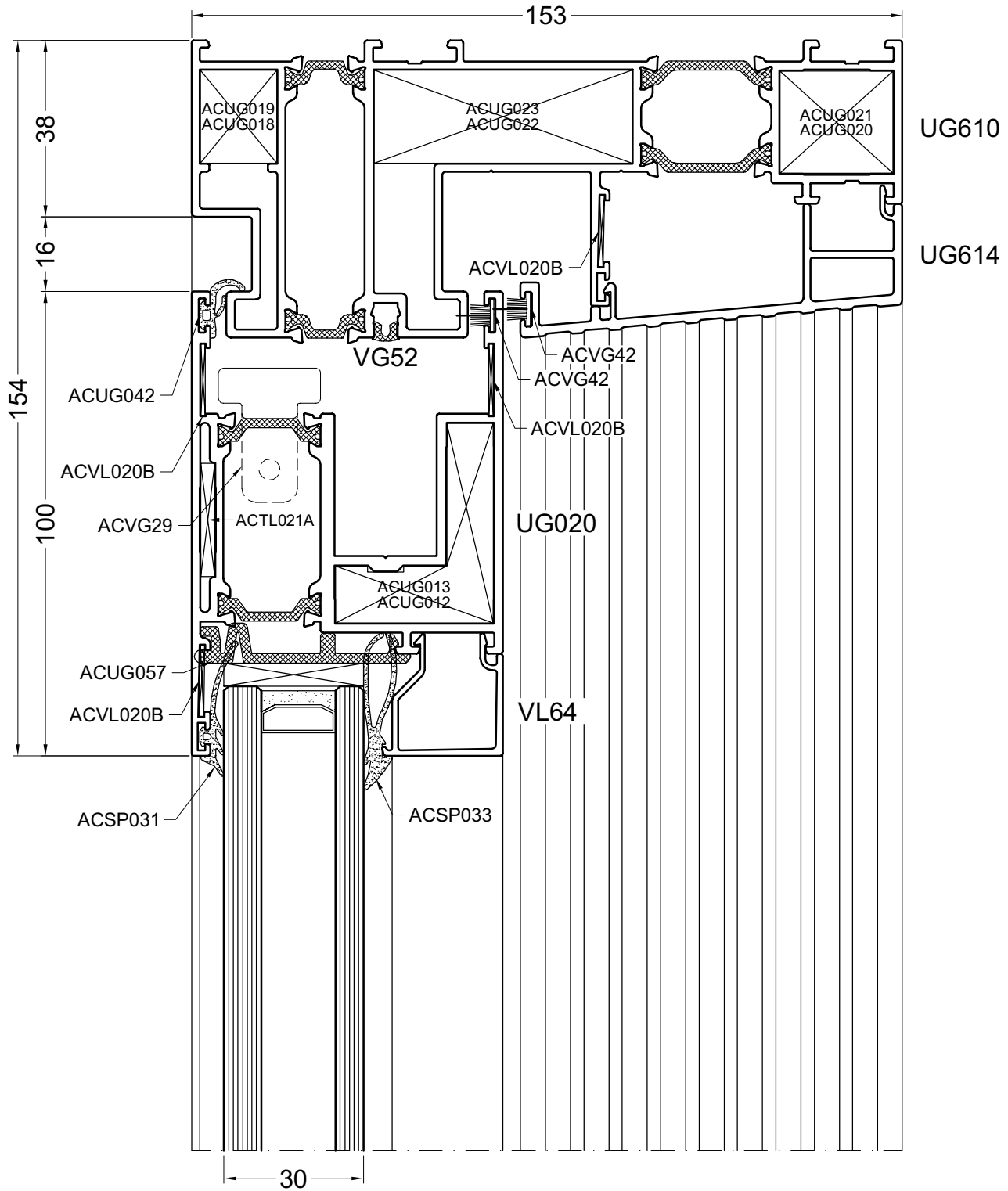

door151

152

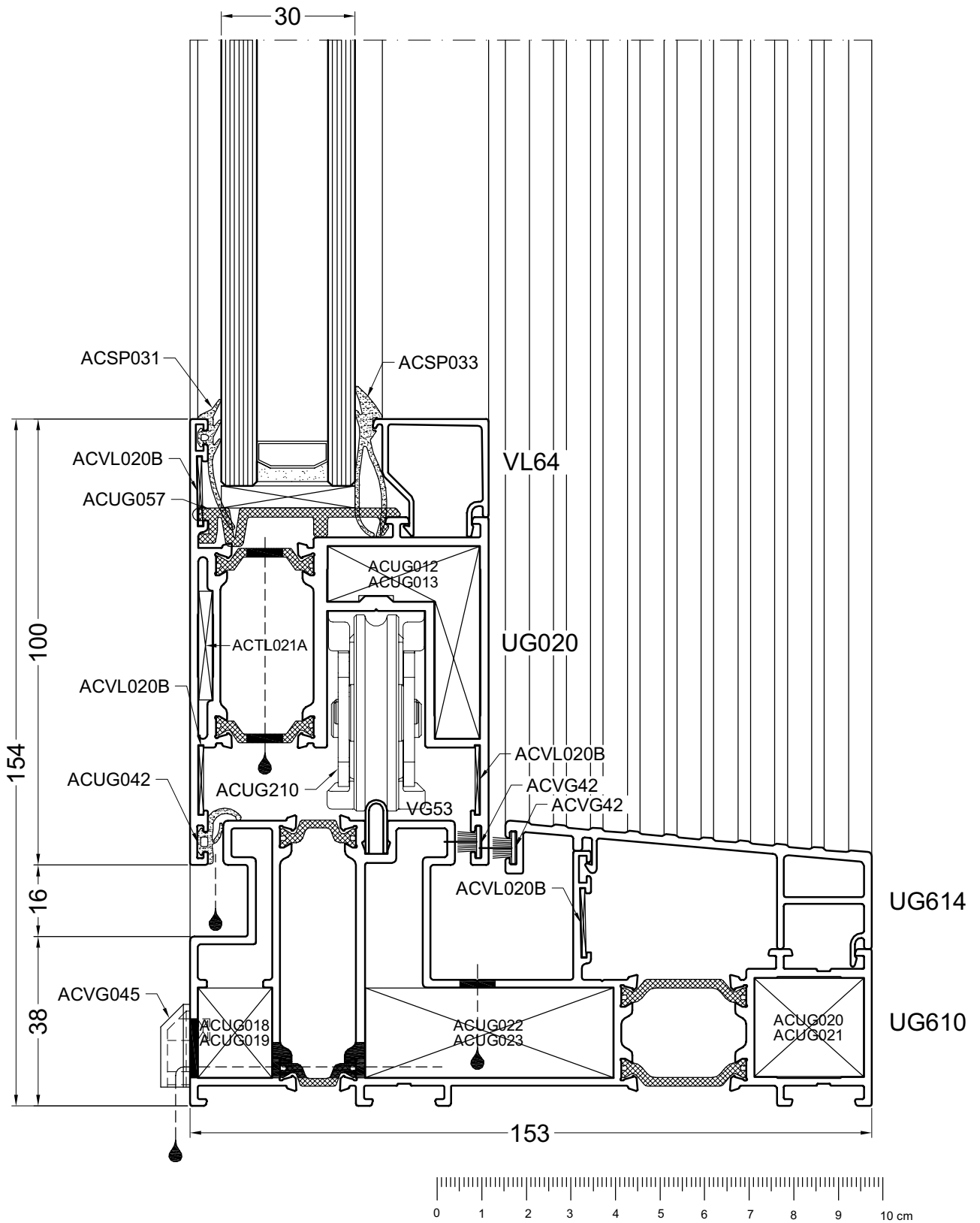

DOORSNEDE - COUPE - SCHNITT - SECTIONS

door152

153A

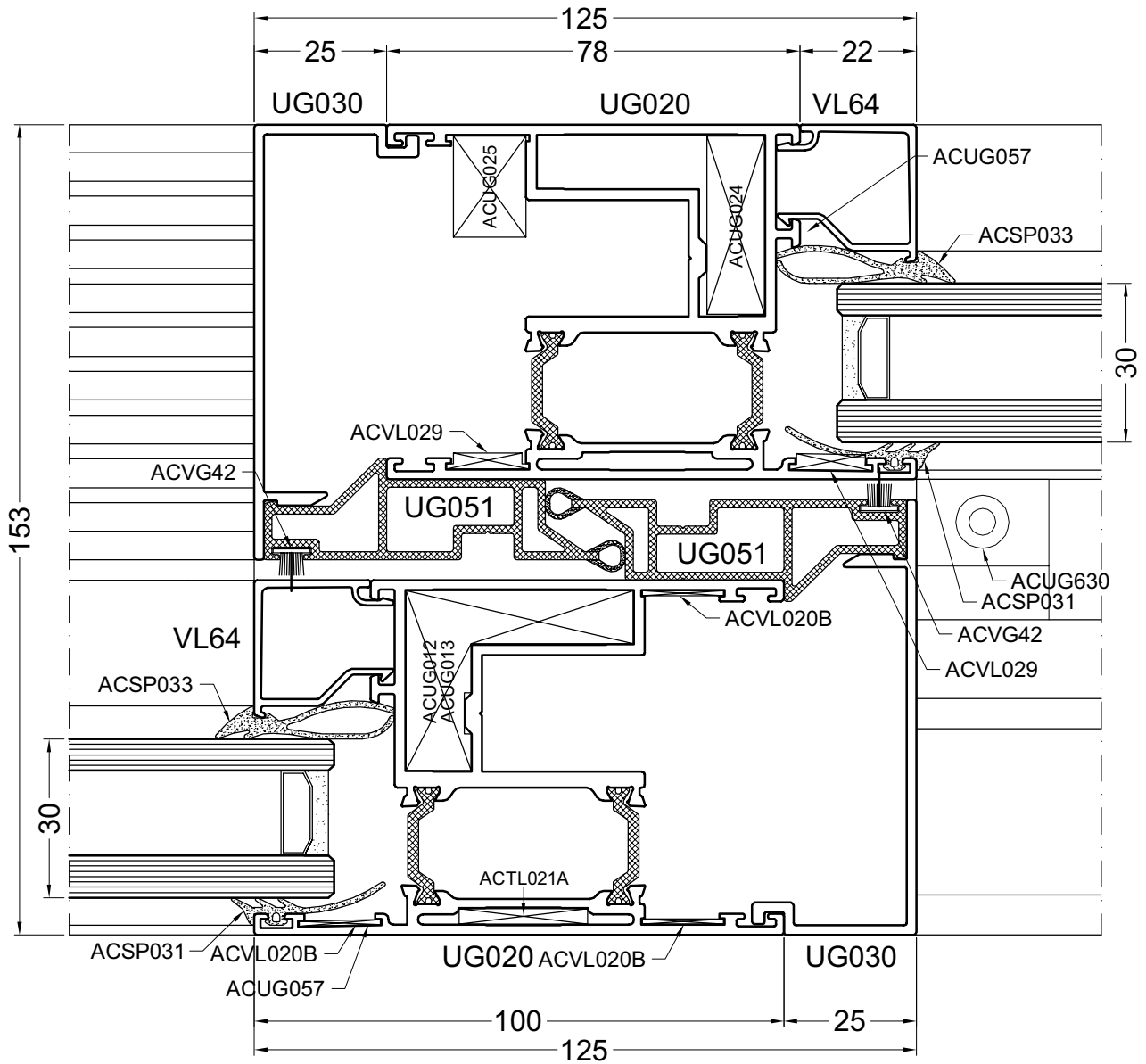

door153

153B

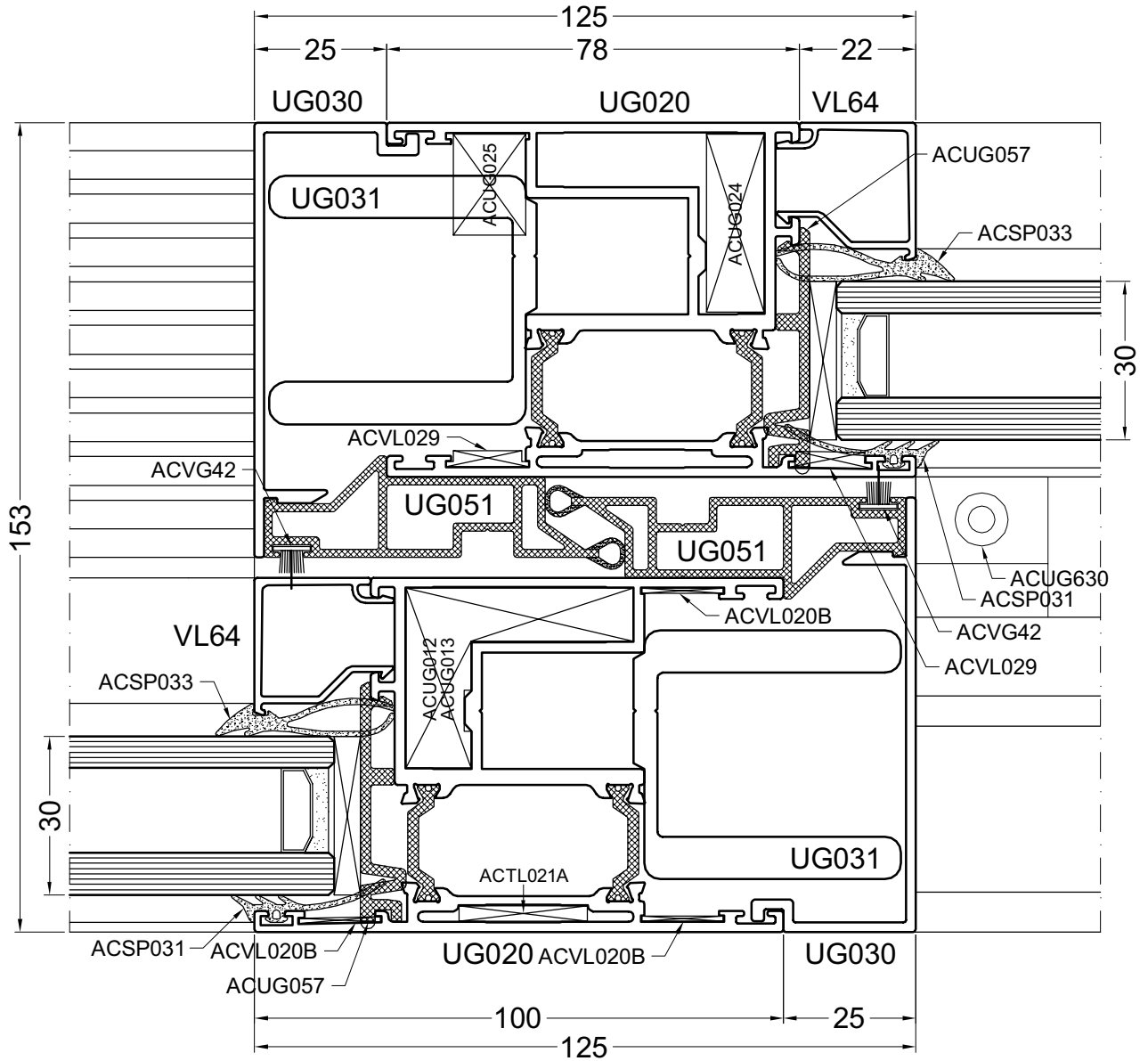

door153a



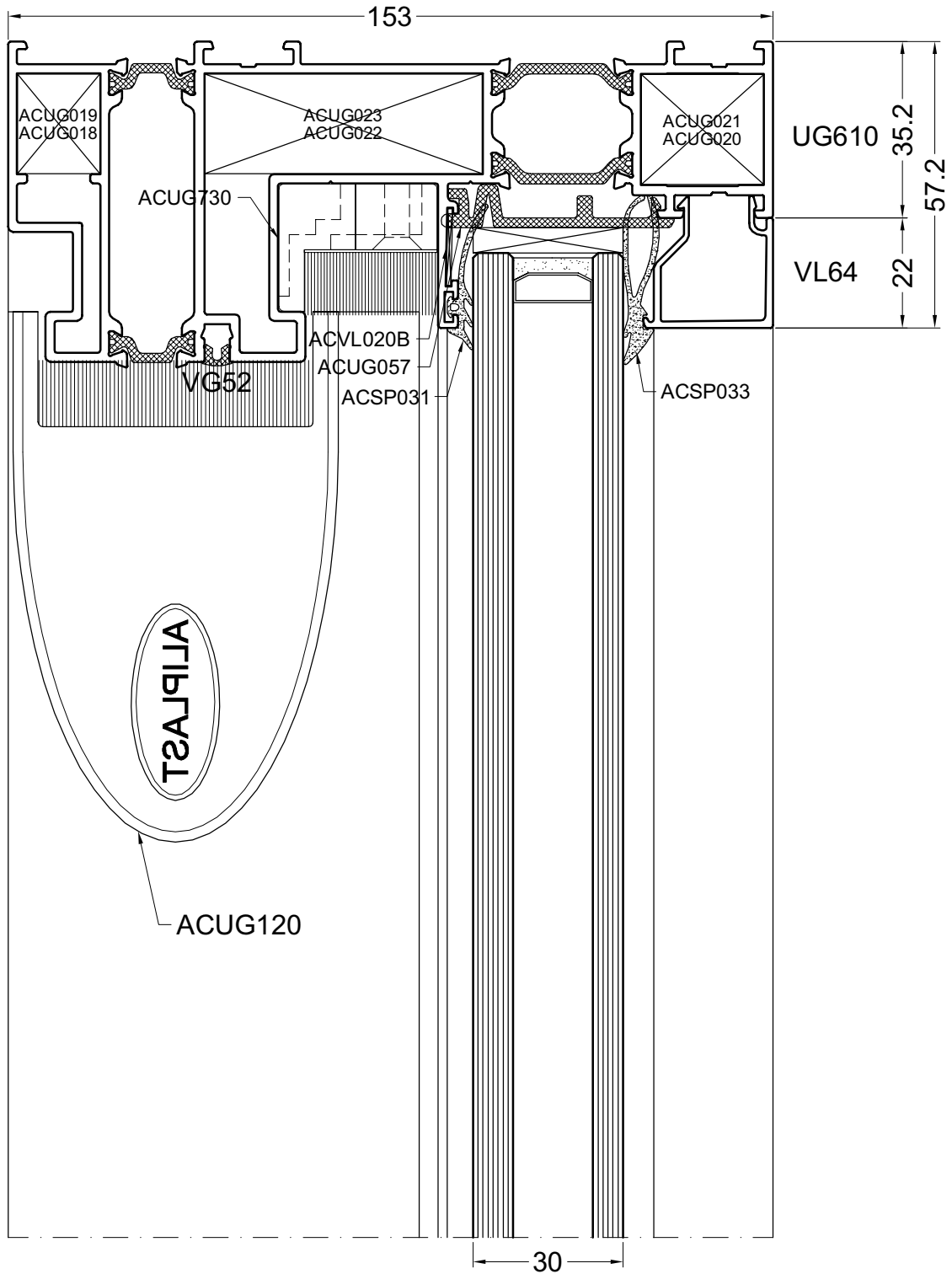

door154

155

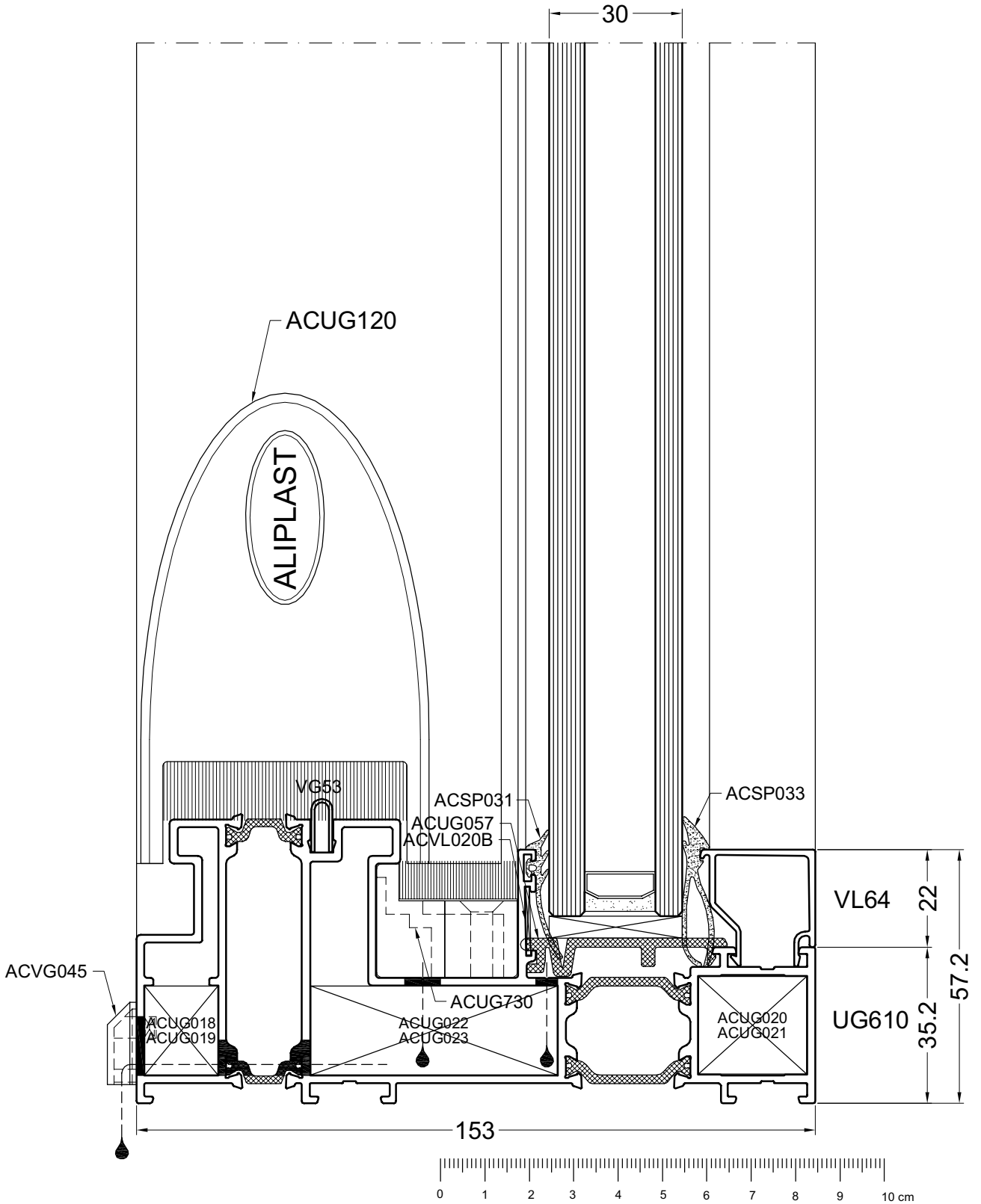

DOORSNEDE - COUPE - SCHNITT - SECTIONS

door155

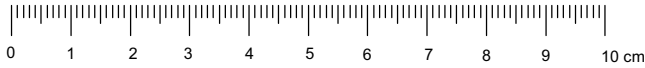
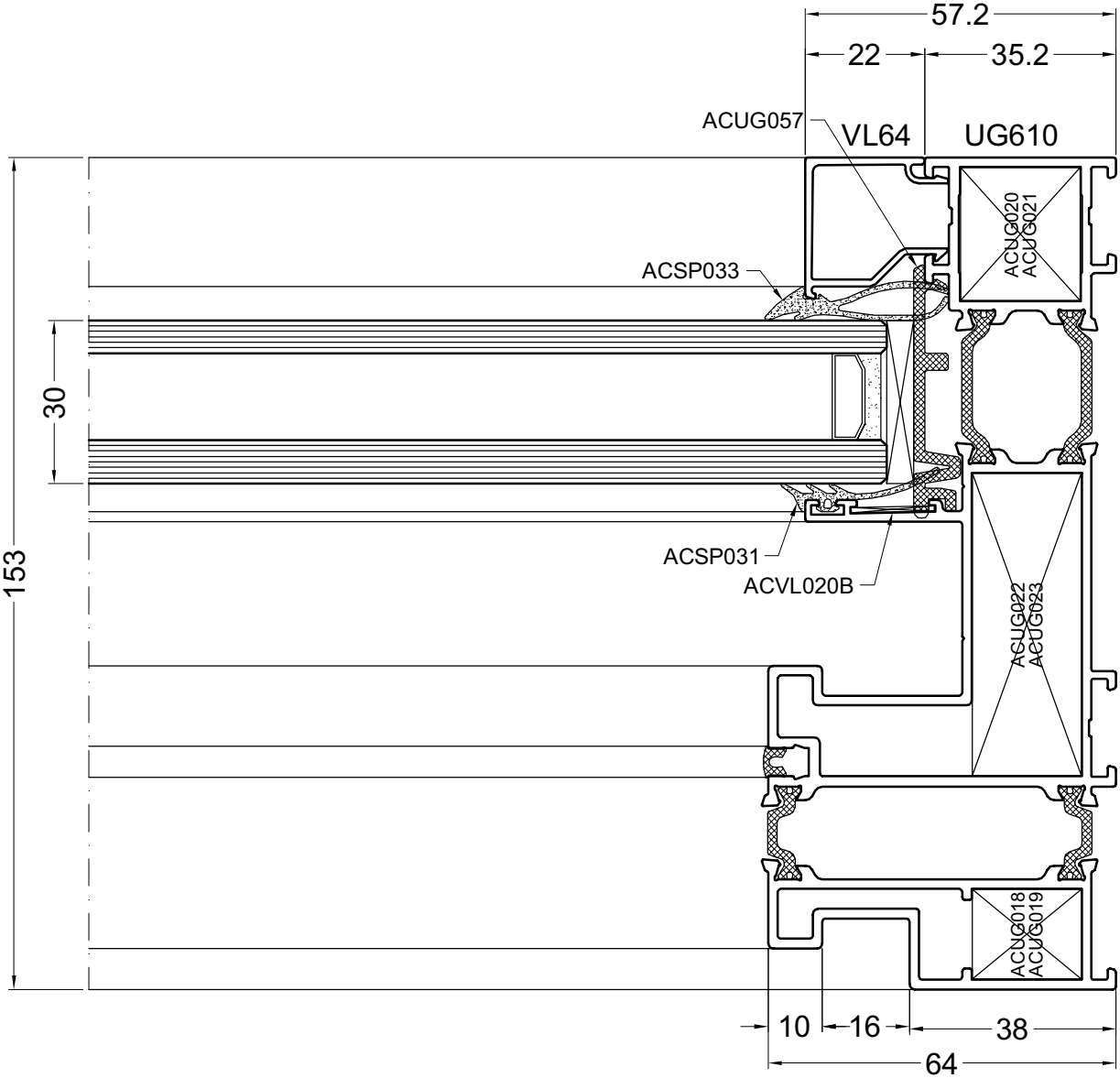

door156

157

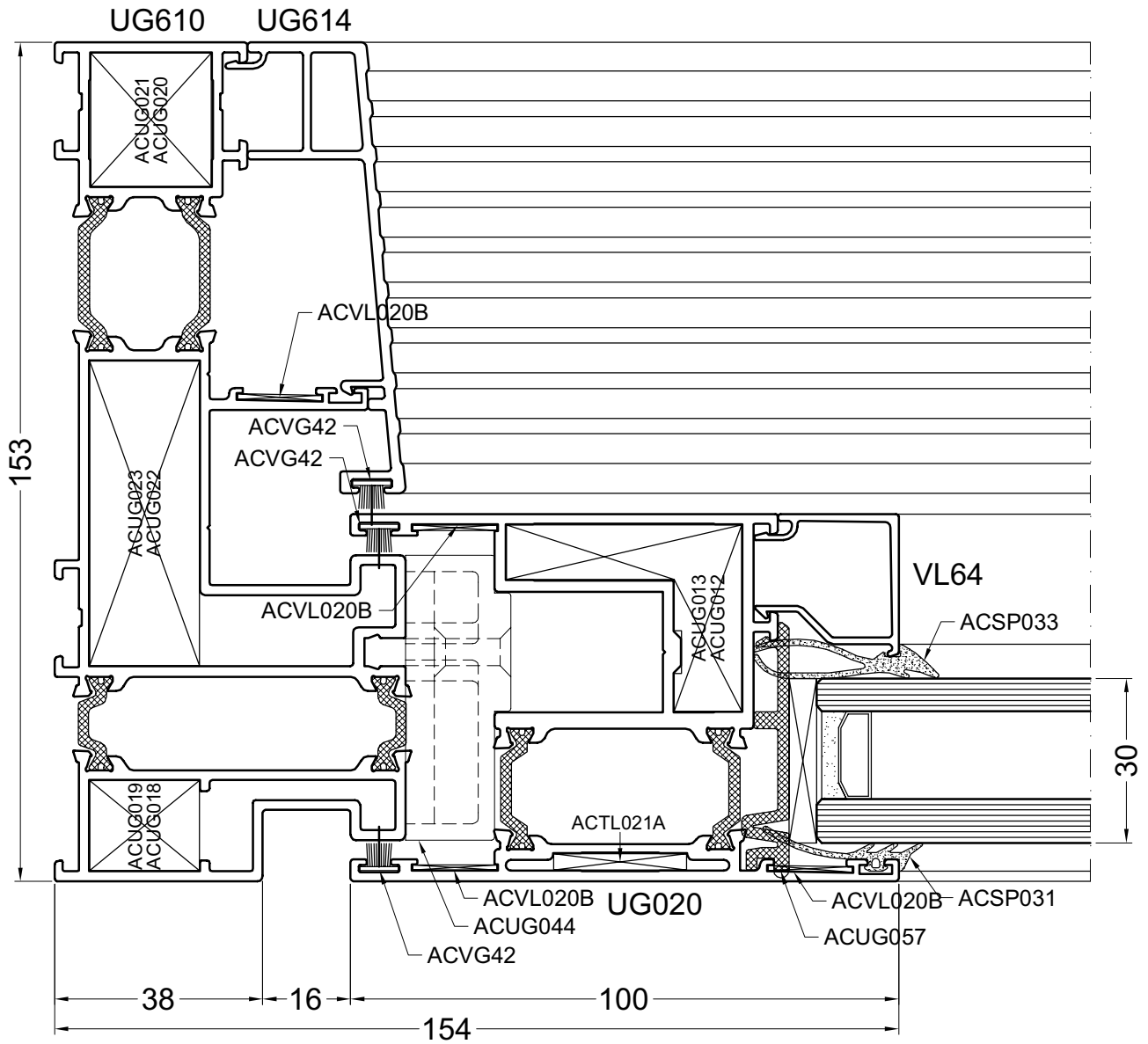

DOORSNEDE - COUPE - SCHNITT - SECTIONS

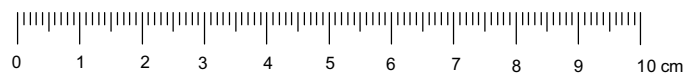

door157

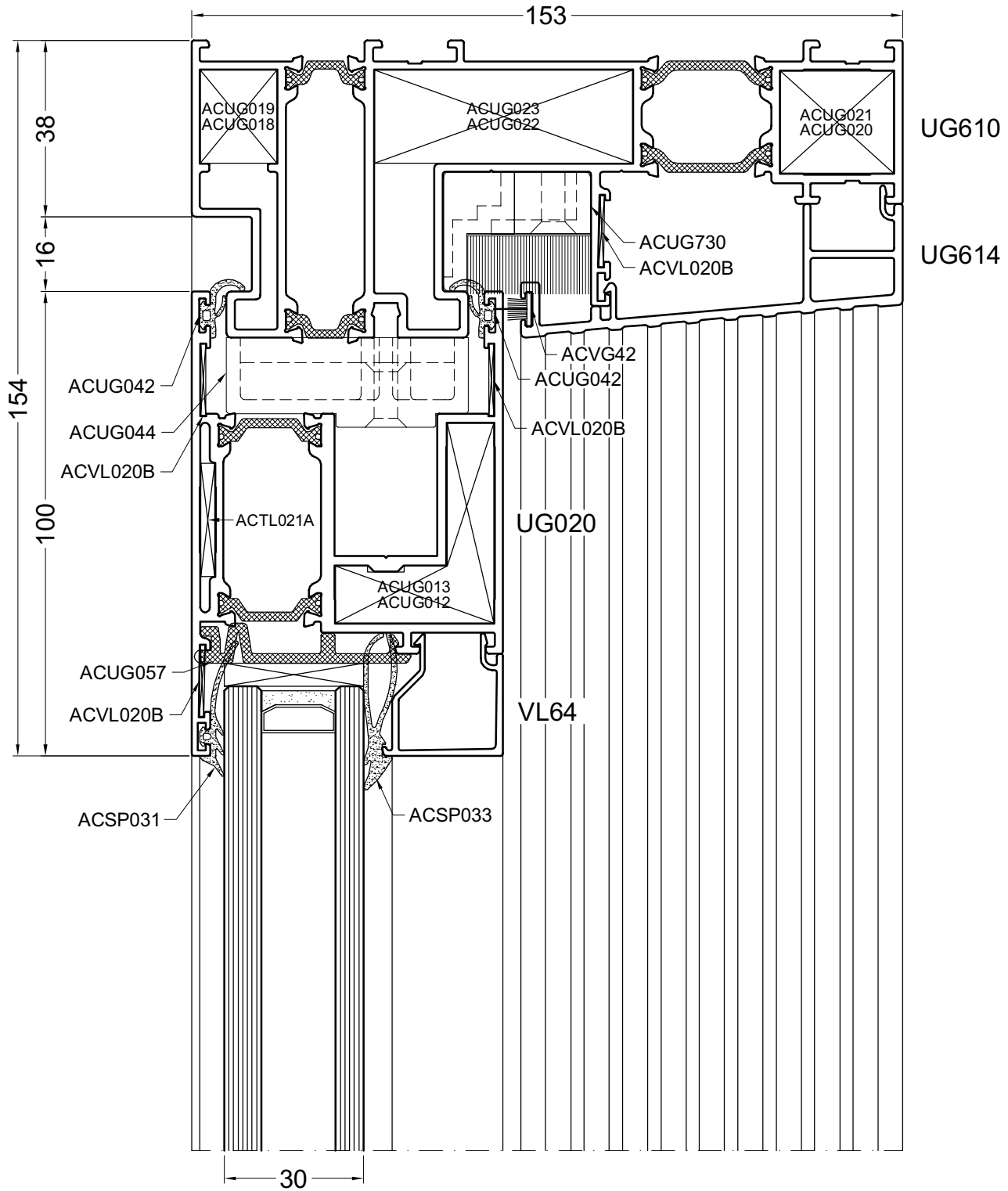

door158

159

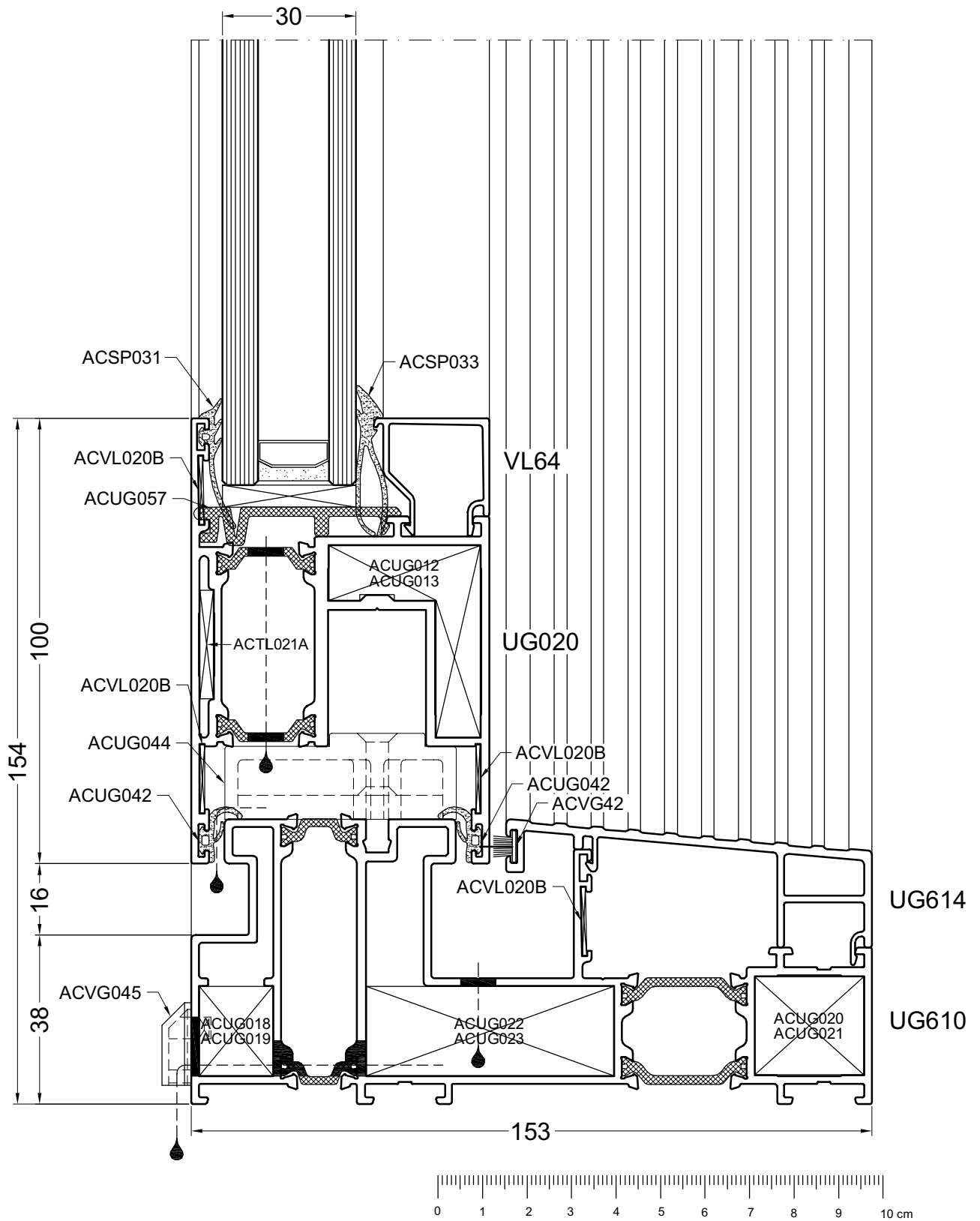

DOORSNEDE - COUPE - SCHNITT - SECTIONS

door159

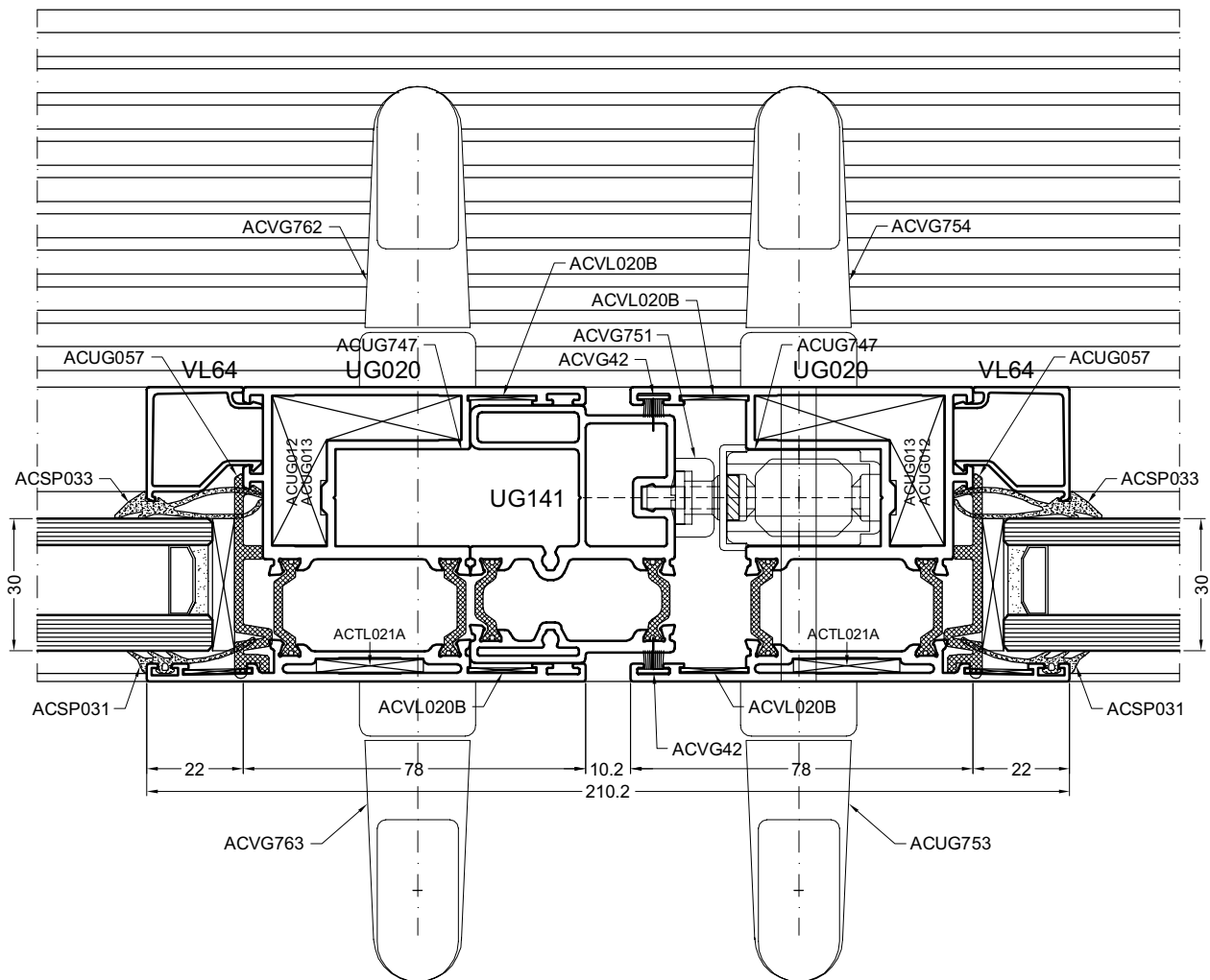

door160

GLASTABELLEN
 TABLES DE VITRAGE
 BEGLAZUNG TABELLEN
 GLAZING TABLES

GLASDIKTE (MM) EPAISSEUR DE VERRE (MM) GLAS DICKE (MM) GLASS THICKNES (MM)	RUBBER BUITEN JOINT EXT. GLASDICHTUNG AUSSEN GASKET OUTSIDE	RUBBER BINNEN JOINT INT. GLASDICHTUNGINNEN GASKET INSIDE	GLASLAT LATTE A VITRAGE VERGLASUNG LATTE GLAZING SLAT
6	ACSP031	ACSP340	IP065
7	ACSP031	ACSP034	IP065
8	ACSP031	ACSP033	IP065
9	ACSP031	ACSP032	IP065
10	ACSP031	ACSP034	SP067
11	ACSP031	ACSP033	SP067
12	ACSP031	ACSP032	SP067
13	ACSP031	ACSP340	SP066
14	ACSP031	ACSP034	SP066
15	ACSP031	ACSP033	SP066
16	ACSP031	ACSP032	SP066
17	ACSP031	ACSP033	IP064
18	ACSP031	ACSP032	IP064
19	ACSP031	ACSP033	SP065
20	ACSP031	ACSP032	SP065
21	ACSP031	ACSP034	VL65
22	ACSP031	ACSP033	VL65
23	ACSP031	ACSP032	VL65
24	ACSP031	ACSP340	VL640
25	ACSP031	ACSP034	VL640
26	ACSP031	ACSP033	VL640
27	ACSP031	ACSP032	VL640
28	ACSP031	ACSP033	IP063

DOORSNEDE - COUPE - SCHNITT - SECTIONS

glastabel1

GLASTABELLEN
 TABLES DE VITRAGE
 BEGLAZUNG TABELLEN
 GLAZING TABLES

GLASDIKTE (MM) EPAISSEUR DE VERRE (MM) GLAS DICKE (MM) GLASS THICKNES (MM)	RUBBER BUITEN JOINT EXT. GLASDICHTUNG AUSSEN GASKET OUTSIDE	RUBBER BINNEN JOINT INT. GLASDICHTUNGINNEN GASKET INSIDE	GLASLAT LATTE A VITRAGE VERGLASUNG LATTE GLAZING SLAT
29	ACSP031	ACSP032	IP063
30	ACSP031	ACSP033	VL64
31	ACSP031	ACSP032	VL64
32	ACSP031	ACSP034	VL630
33	ACSP031	ACSP033	VL630
34	ACSP031	ACSP032	VL630
35	ACSP031	ACSP034	VL63
36	ACSP031	ACSP033	VL63
37	ACSP031	ACSP032	VL63
38	ACSP031	ACSP340	VL62
39	ACSP031	ACSP034	VL62
40	ACSP031	ACSP033	VL62
41	ACSP031	ACSP032	VL62
42	ACSP031	ACSP033	VL612
43	ACSP031	ACSP032	VL612
44	ACSP031	ACSP033	VL611
45	ACSP031	ACSP032	VL611
46	ACSP031	ACSP340	VL610
47	ACSP031	ACSP034	VL610
48	ACSP031	ACSP033	VL610
49	ACSP031	ACSP032	VL610
50	ACSP031	ACSP340	VL61
51	ACSP031	ACSP034	VL61
52	ACSP031	ACSP033	VL61
53	ACSP031	ACSP032	VL61

glastabel2

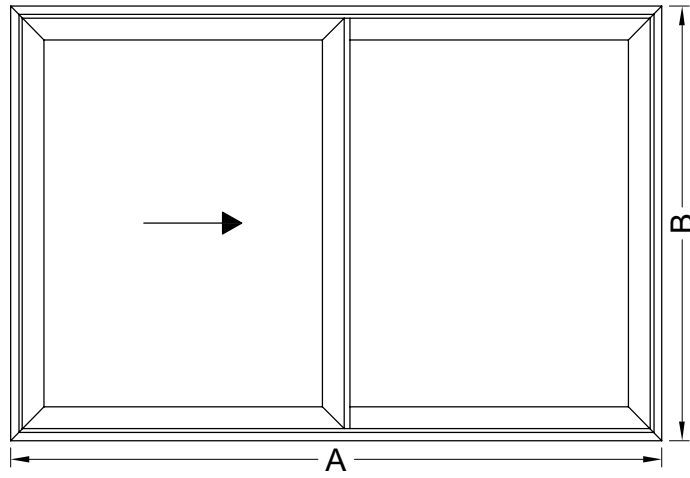

$I_{xx} = 145.08 \text{ cm}^4$
 $f_{max} = B/360 < 8 \text{ mm}$

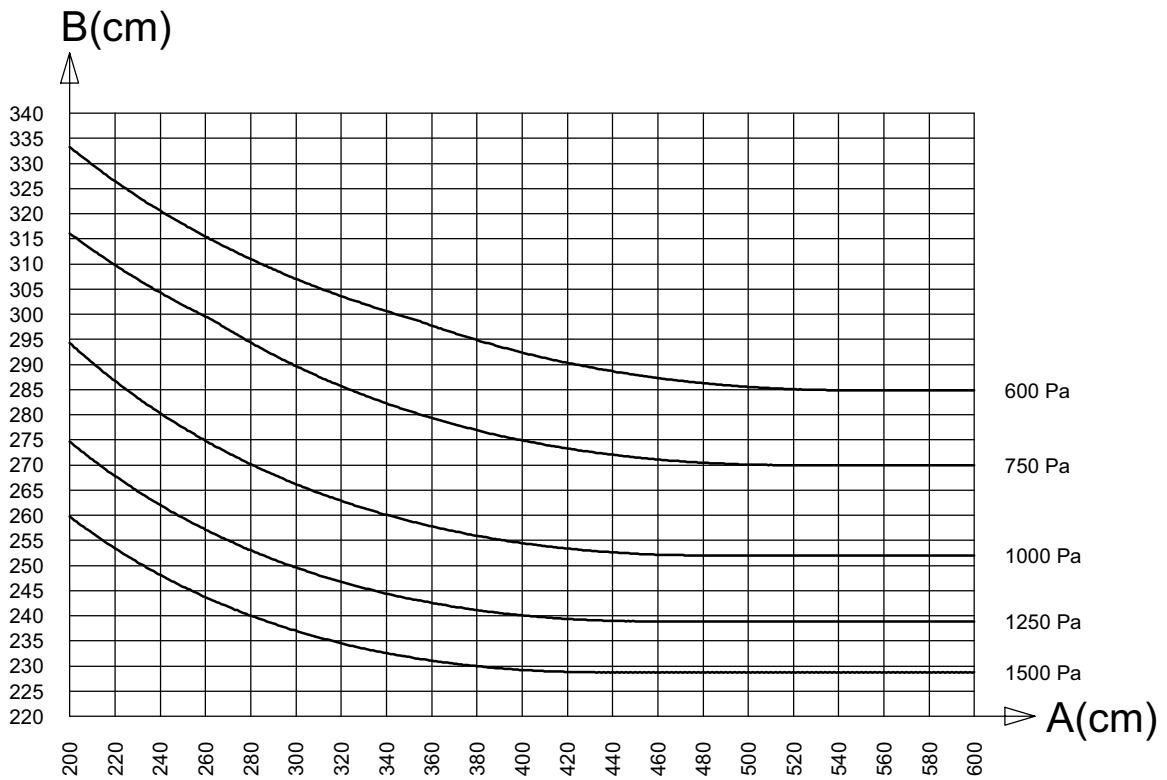
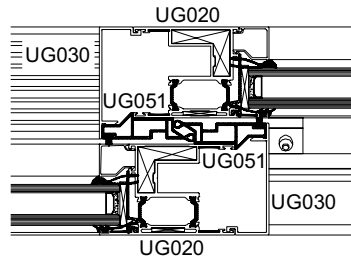

statica1

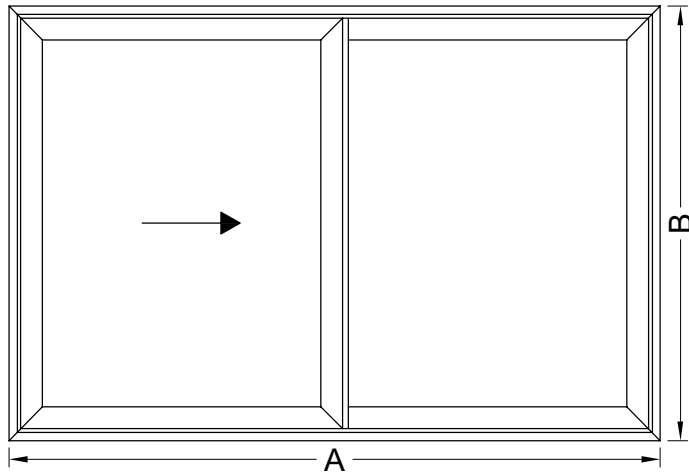

$I_{xx} = 175.55 \text{ cm}^4$
 $f_{max} = B/360 < 8 \text{ mm}$

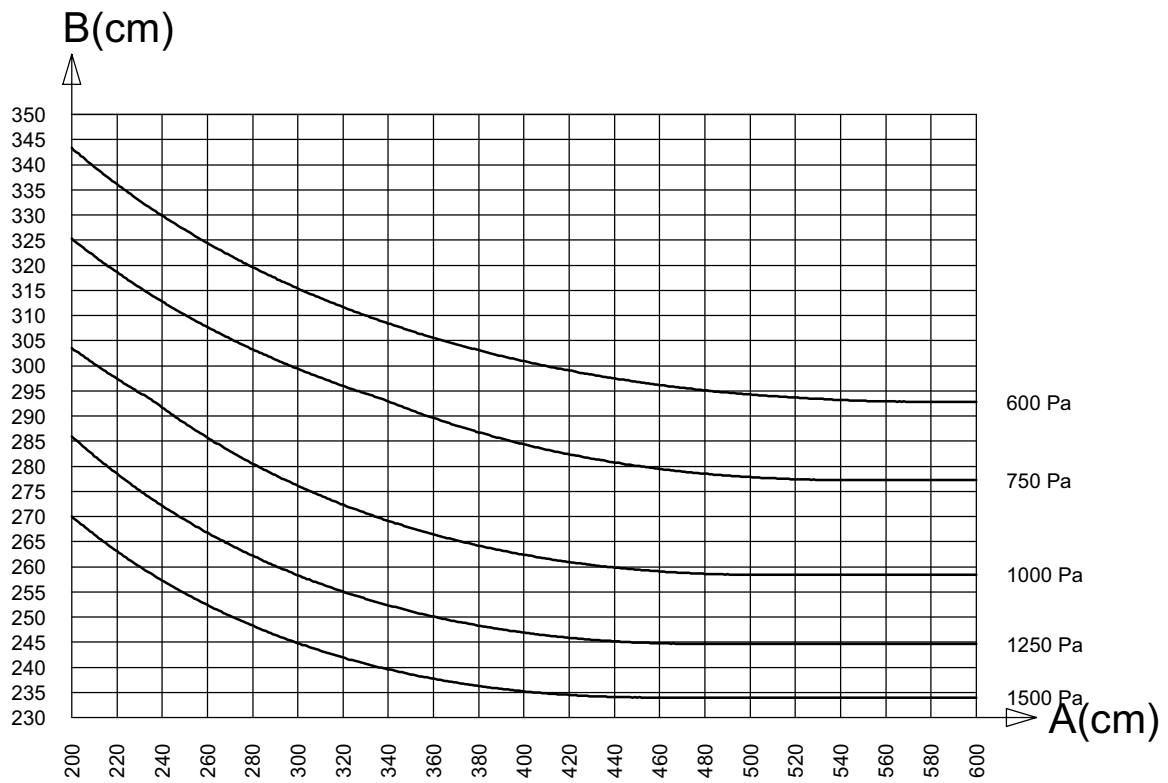
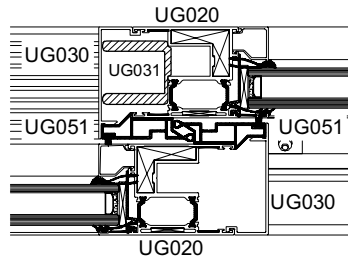

statica2

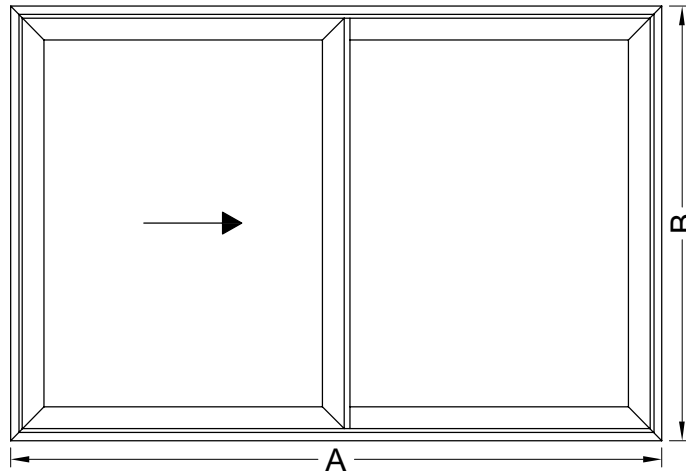

$I_{xx} = 206.02 \text{ cm}^4$
 $f_{max} = B/360 < 8 \text{ mm}$

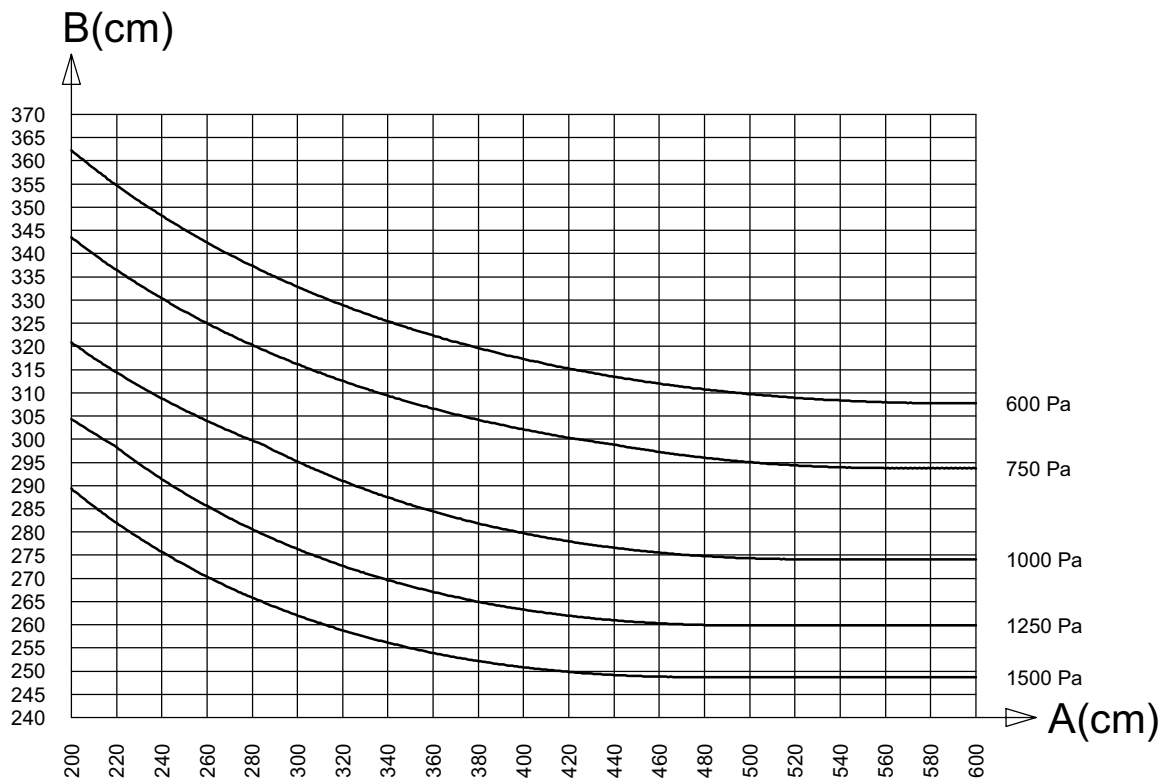
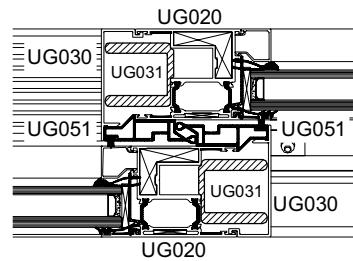

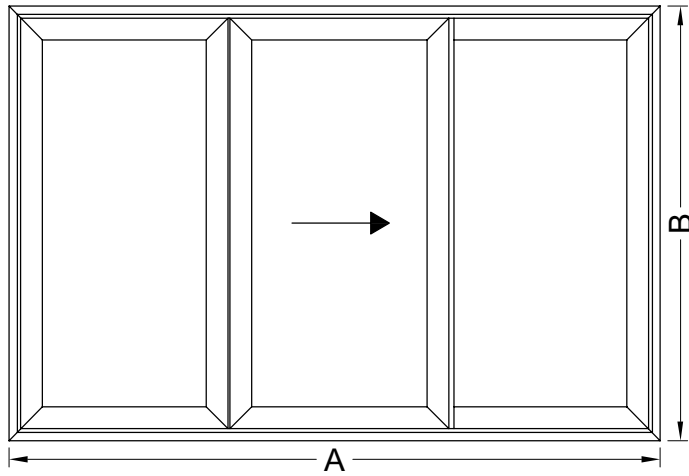

$I_{xx} = 128.21 \text{ cm}^4$
 $f_{max} = B/360 < 8 \text{ mm}$

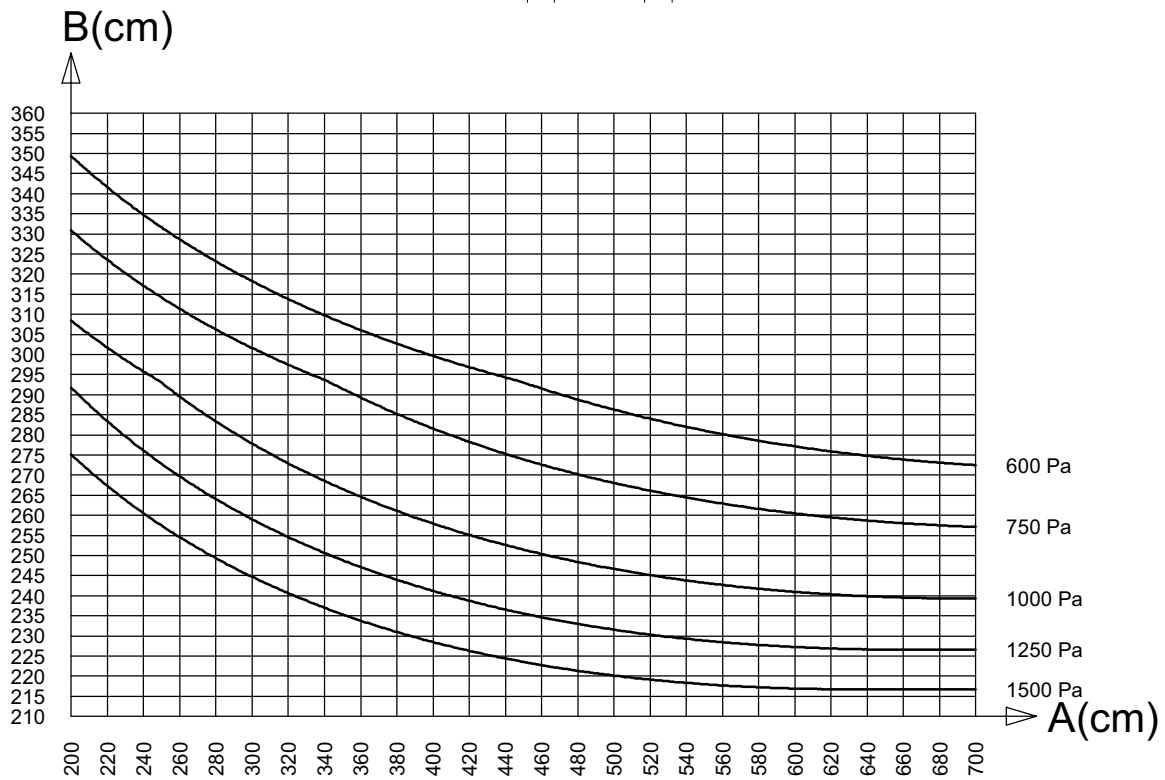
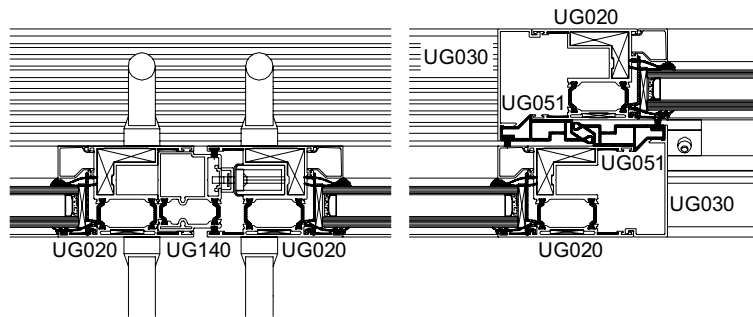

statica5

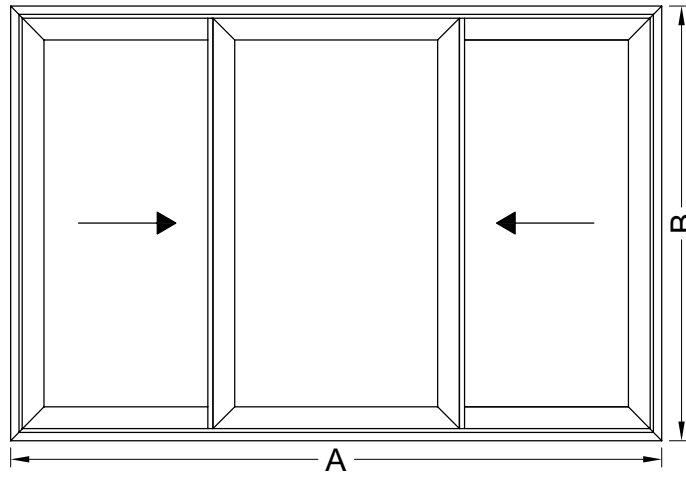

$I_{xx} = 145.08 \text{ cm}^4$
 $f_{max} = B/360 < 8 \text{ mm}$

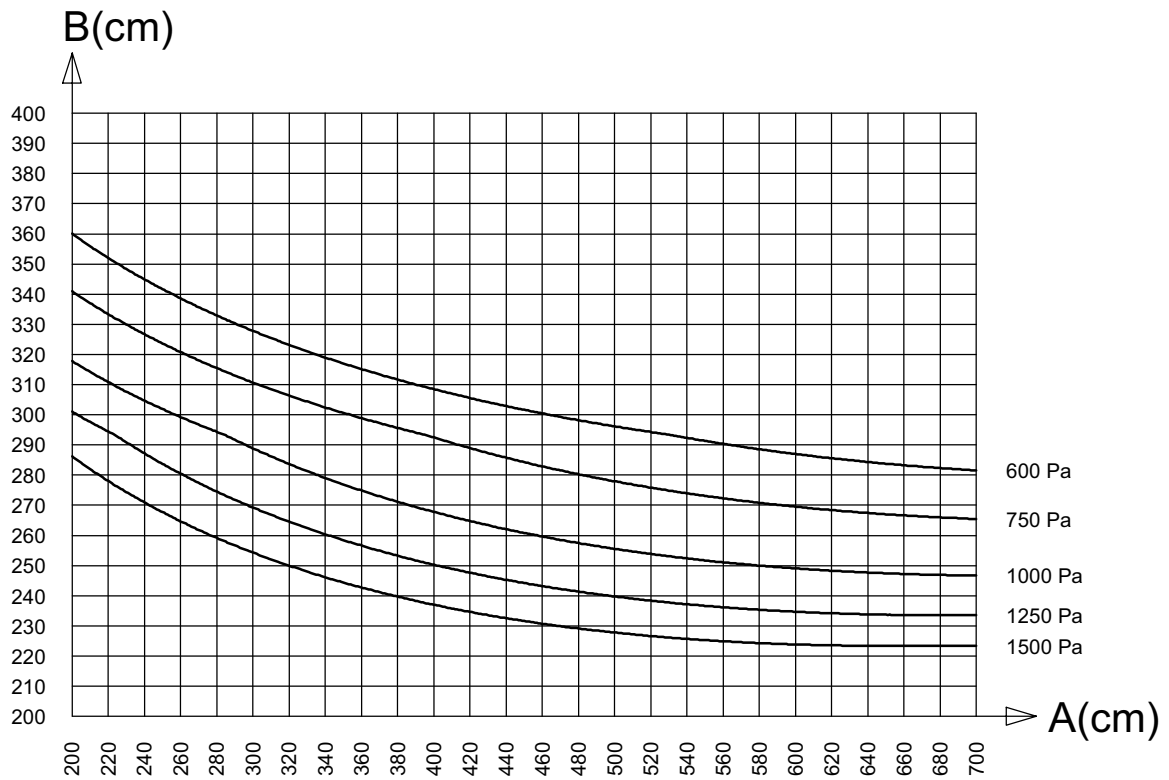
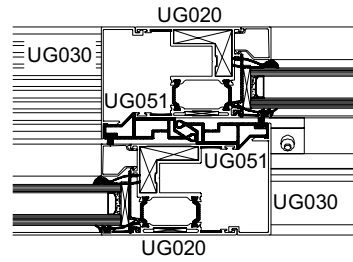

statica6

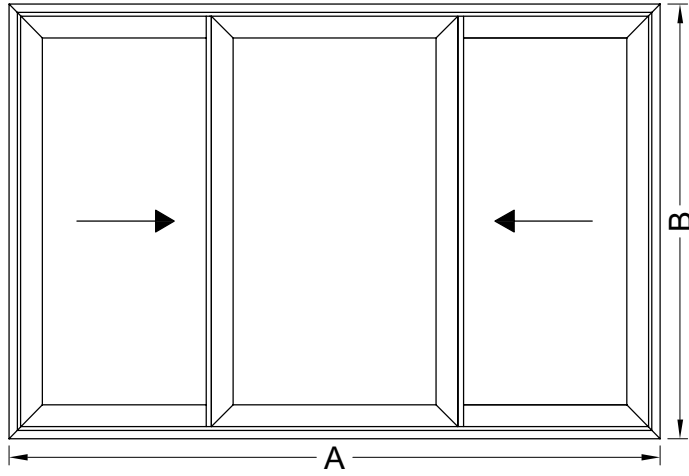

$I_{xx} = 175.55 \text{ cm}^4$
 $f_{max} = B/360 < 8 \text{ mm}$

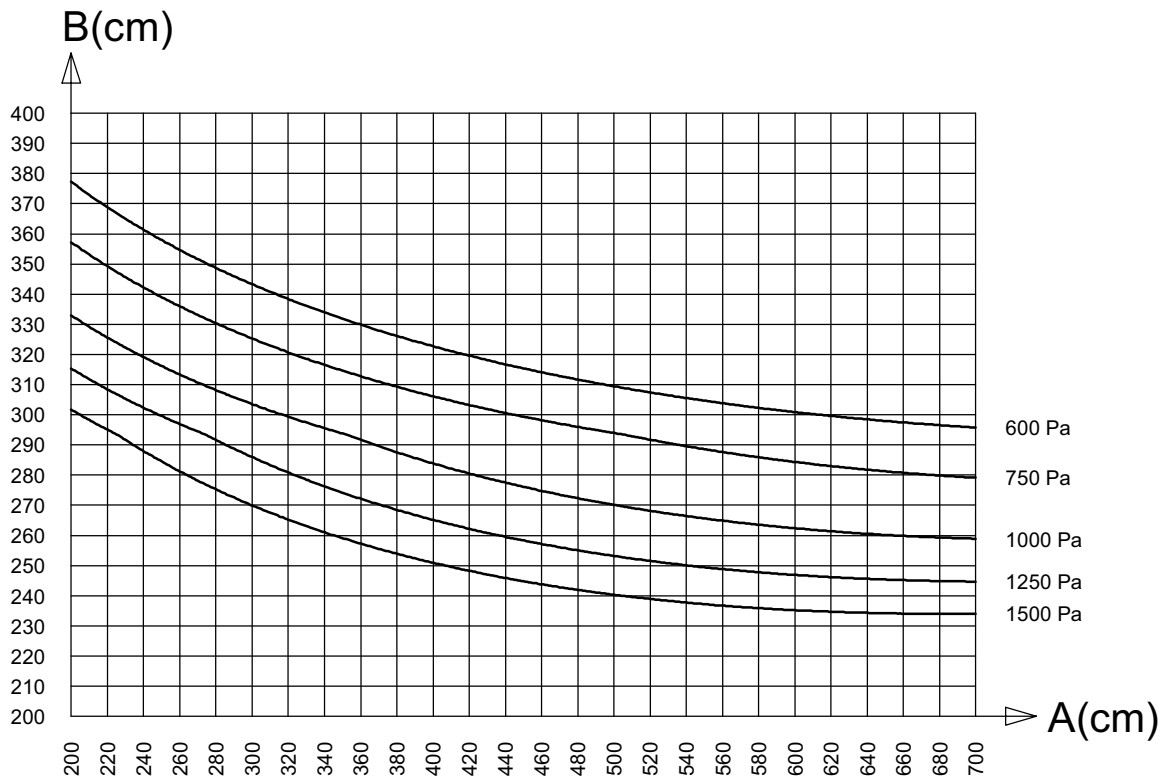
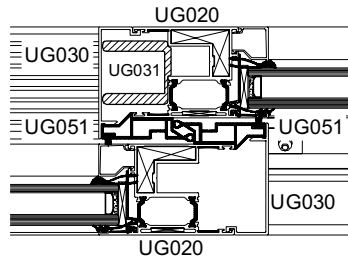

statica7

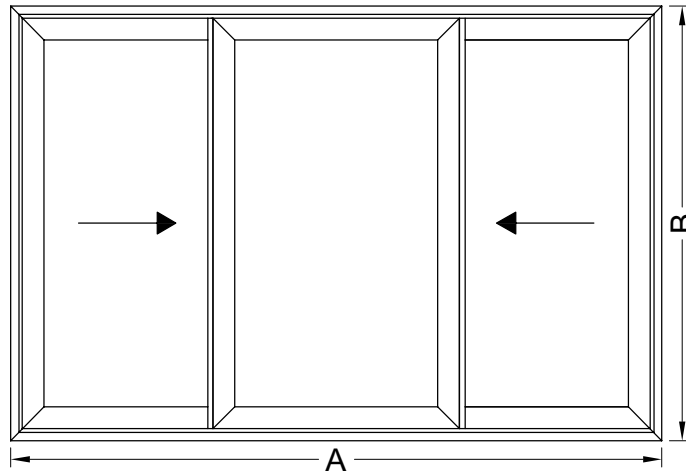

$I_{xx} = 206.02 \text{ cm}^4$
 $f_{max} = B/360 < 8 \text{ mm}$

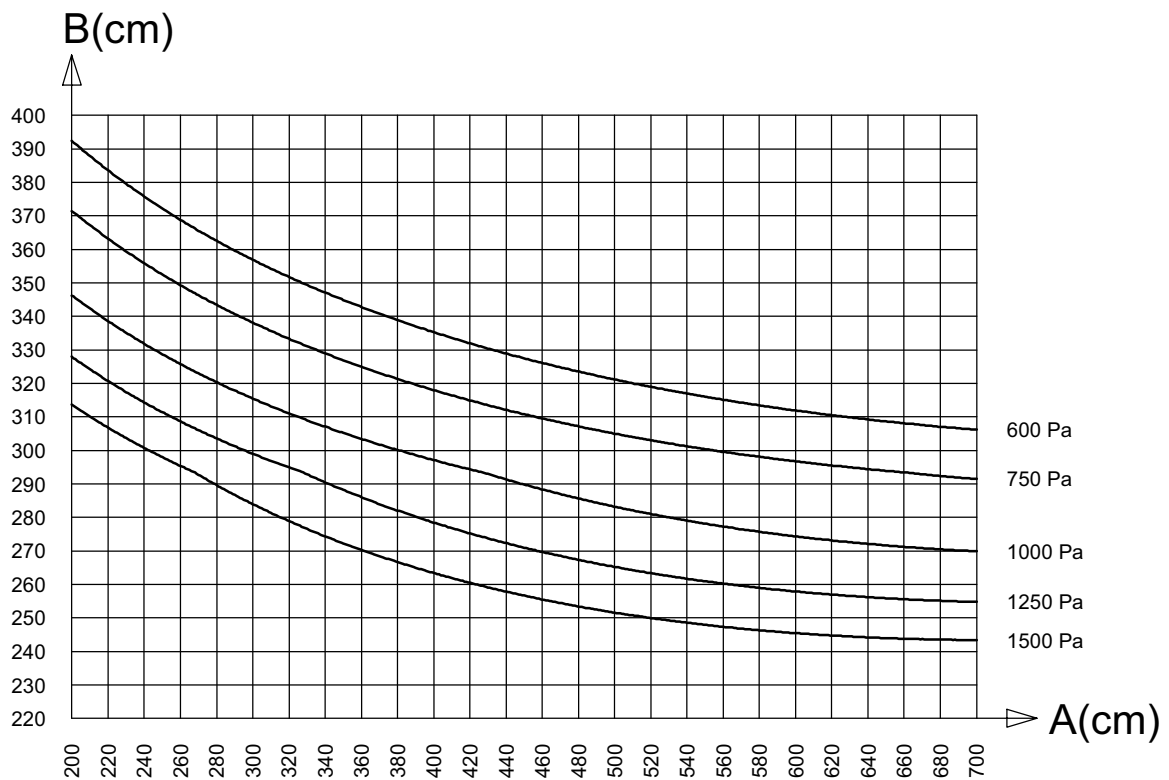
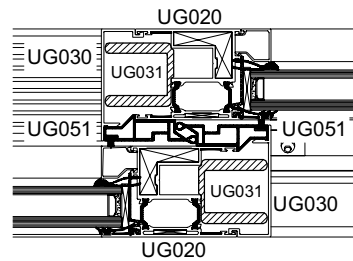

STATICA - STATIQUE - STATIK - STATICS

statica8

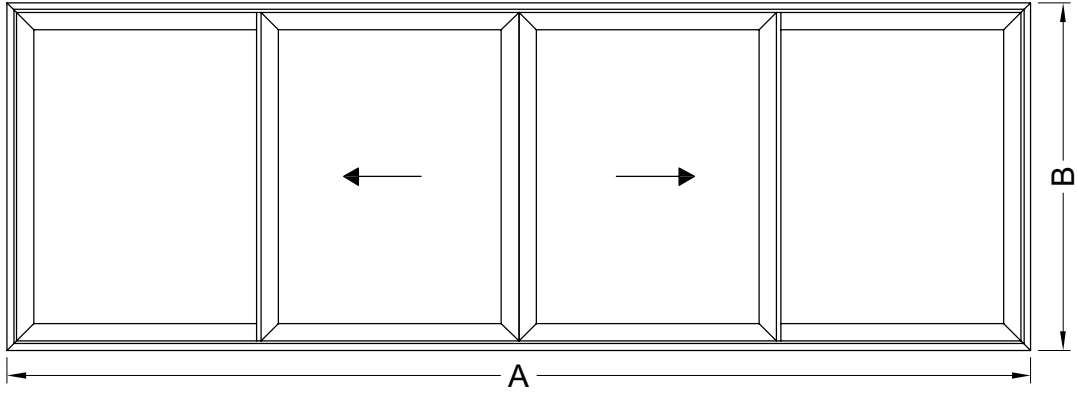

$I_{xx} = 128.21 \text{ cm}^4$
 $f_{max} = B/360 < 8 \text{ mm}$

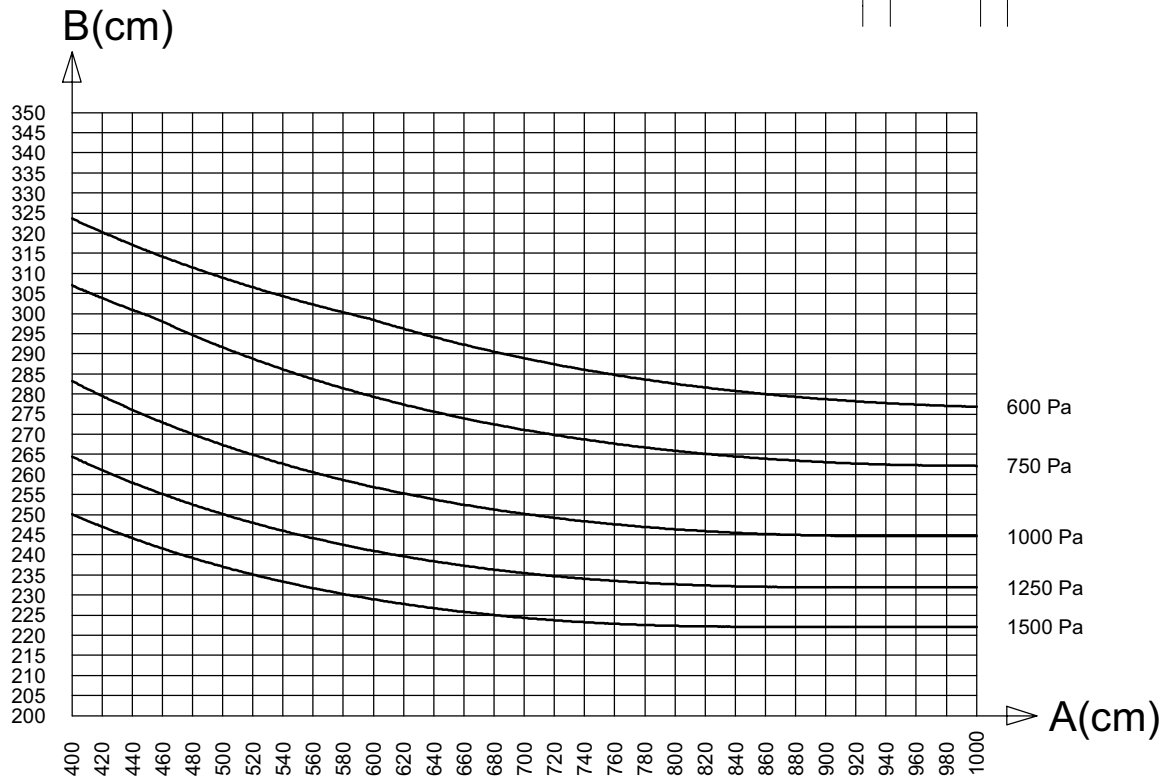
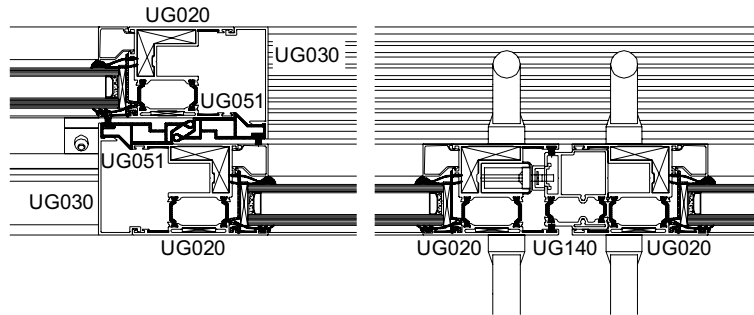

statica4

2 VLEUGELIG SCHUIFRAAM
FENETRE COULISSANTE 2 VANTAUX
SCHIEBEFENSTER 2 FLUGEL
DOUBLE SLIDING WINDOW

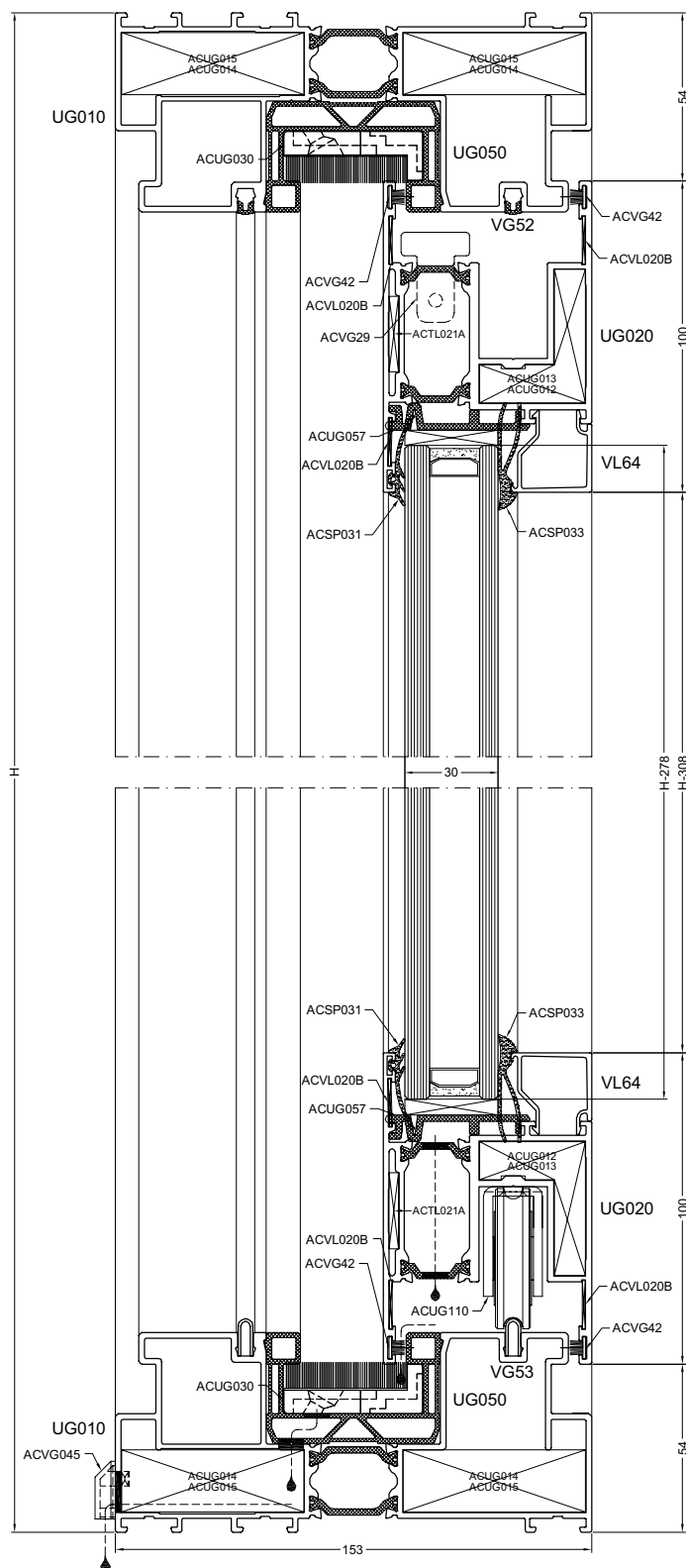

PROFIELN / PROFILES / PROFILS / PROFILS

UG010		2		H
UG010		2		B
UG020		4		H-108
UG020		4		B/2-16.5
VL*		4		H-308
VL*		4		B/2-172.5
UG050		2		H-57
UG050		2		B-57
UG030		2		H-108
UG051		2		H-108
VG52		2		H-133
VG52		2		B-128
VG53		2		B-118

GLASMATEN
DIMENSIONS DES VITRAGES
GLASSMASSE
GLASS SIZE

2X B/2-186.5
H-278

MAXIMAAL VLEUGELGEWICHT
POIDS MAXIMUM PAR VANTAIL
MAXIMAL FLUGELGEWICHT
MAX. WEIGHT OF THE VENT

250 KG

TOEBEHOREN / ACCESSOIRES
ZUBEHÖRTEILE / ACCESSORIES

ACUG014/015	8
ACTL021A	8
ACVL020B	24
ACUG057	8
ACUG030	1
ACUG48	2
ACVG45	2
ACVG29	2
ACUG120	2
ACUG110	4
ACUG040	2
ACUG746	10
ACUG747	8
ACVG751	2
ACVG754	2
ACUG753	2
ACMX01621	2
ACSP031	4H+2B-1600
ACSP033	4H+2B-1600
ACVG42	7H+5B-1400

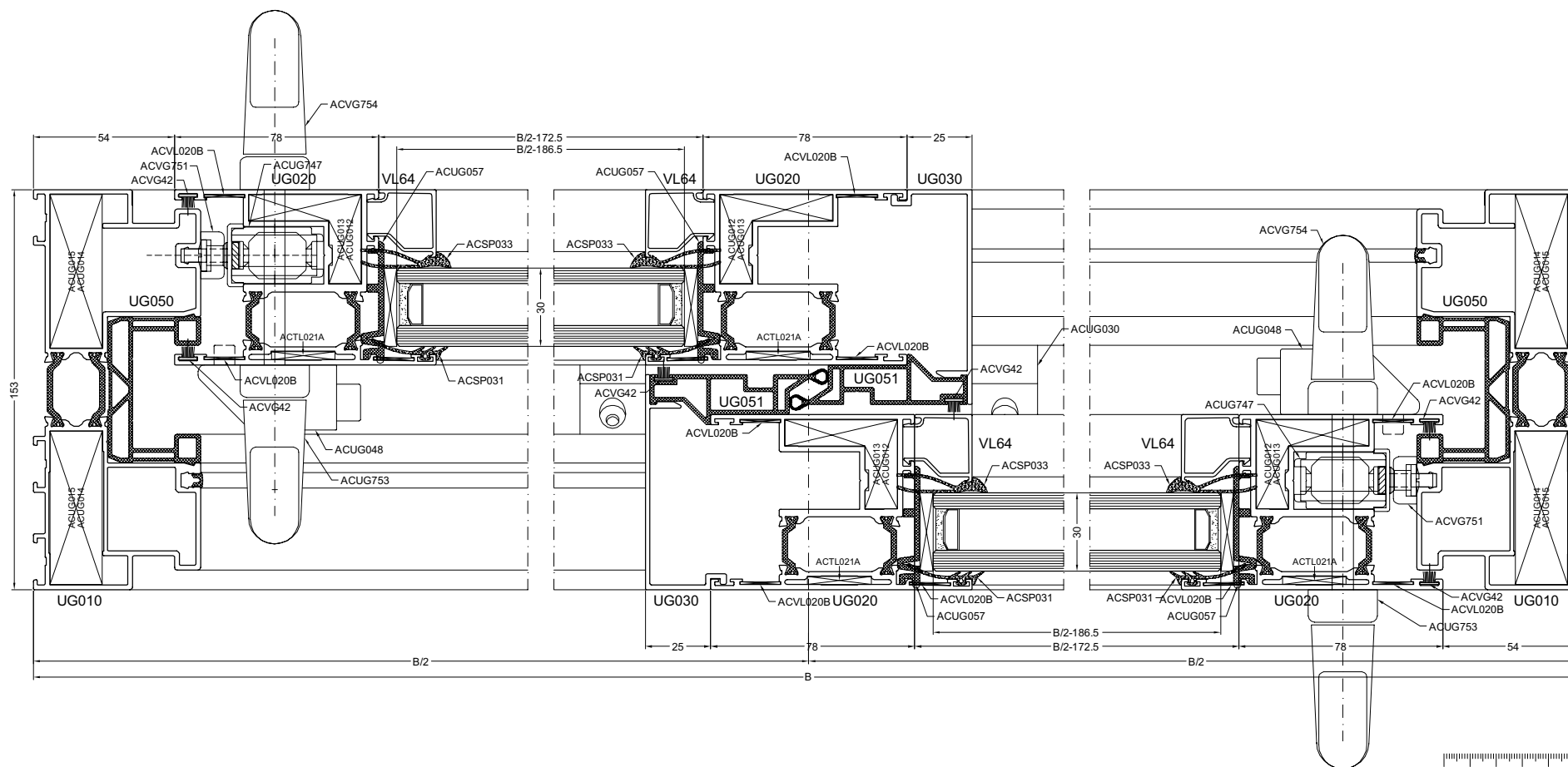
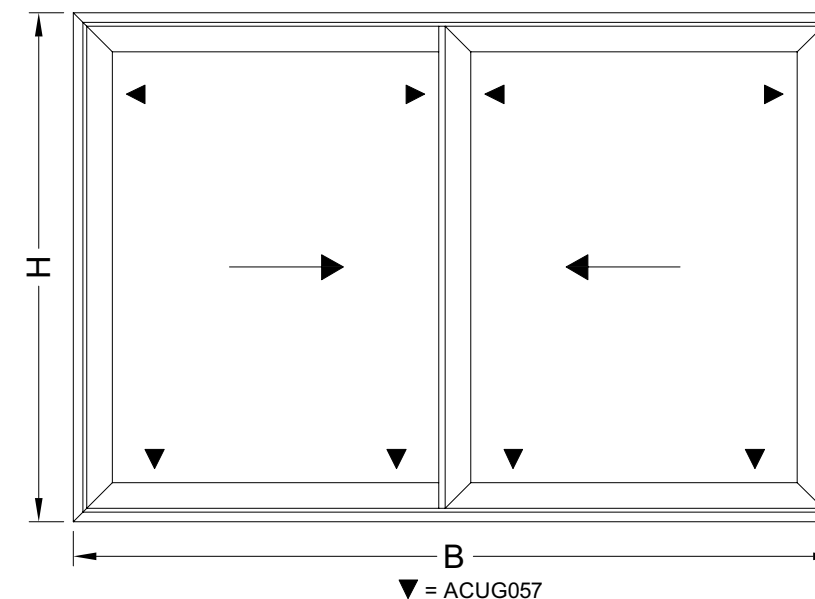

zaag1

ZAAGTABELLEN - TABLES DE SCIAGES - ZUSCHNITT-TABELLEN - SAWING TABLES

2 VLEUGELIG SCHUIFRAAM
FENETRE COULISSANTE 2 VANTAUX
SCHIEBEFENSTER 2 FLUGEL
DOUBLE SLIDING WINDOW

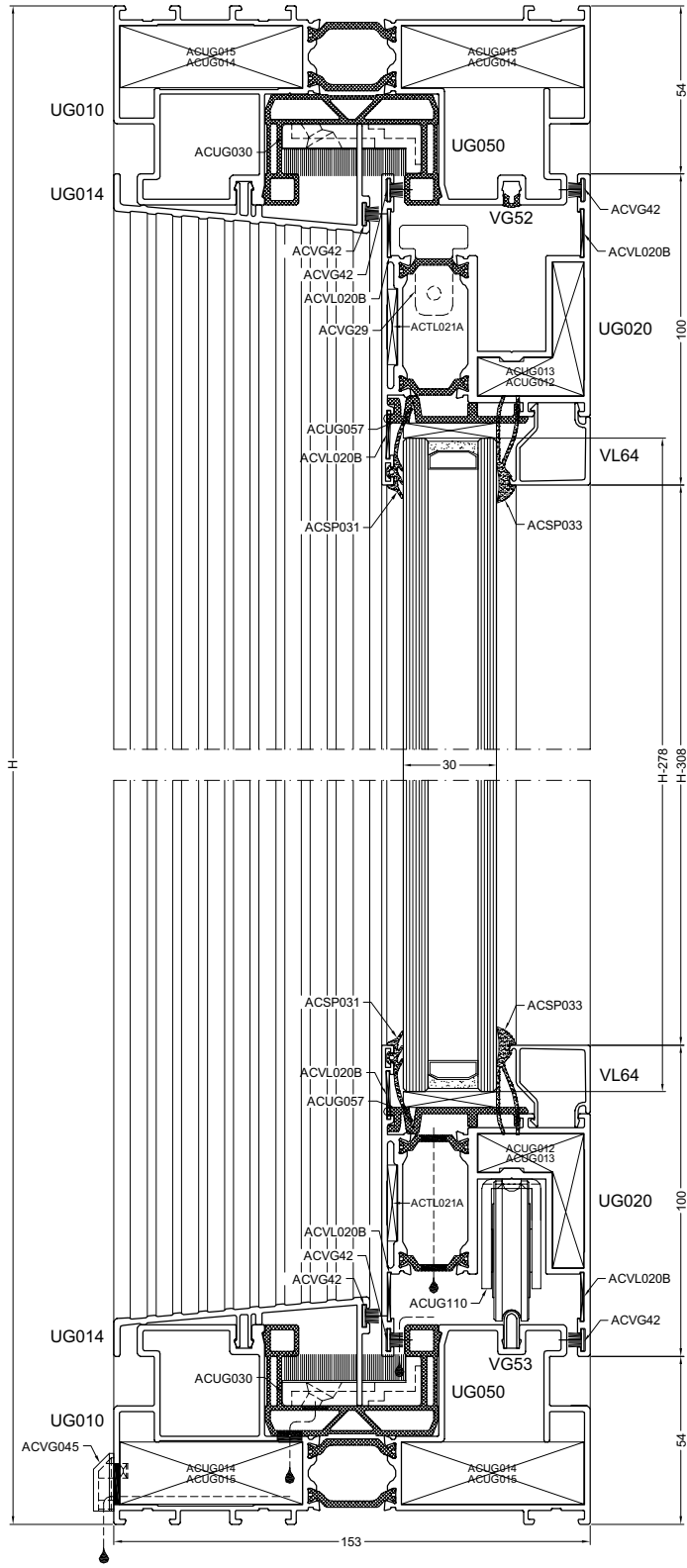

PROFIELN / PROFILES / PROFILS / PROFILS

UG010		2		H
UG010		2		B
UG020		4		H-108
UG020		4		B/2-16.5
VL*		4		H-308
VL*		4		B/2-172.5
UG050		2		H-57
UG050		2		B-57
UG030		2		H-108
UG051		2		H-108
UG014		1		H-76
UG014		2		B/2-100.5
VG52		2		H-133
VG52		1		B-128
VG53		1		B-118

GLASMATEN
 DIMENSIONS DES VITRAGES
 GLASSMASSE
 GLASS SIZE

**2X B/2-186.5
 H-278**

MAXIMAAL VLEUGELGEWICHT
 POIDS MAXIMUM PAR VANTAIL
 MAXIMAL FLUGELGEWICHT
 MAX. WEIGHT OF THE VENT

250 KG

**TOEBEHOREN / ACCESSOIRES
 ZUBEHÖRTEILE / ACCESSORIES**

ACUG014/015	8
ACUG012/013	8
ACTL021A	8
ACVL020B	24
ACUG057	8
ACUG044	5
ACUG030	1
ACUG48	1
ACVG45	2
ACVG29	1
ACUG120	1
ACUG110	2
ACUG040	1
ACUG746	5
ACUG747	4
ACUG751	1
ACVG754	1
ACUG753	1
ACMX01621	1
ACSP031	4H+2B-1600
ACSP033	4H+2B-1600
ACVG42	7H+5B-1400

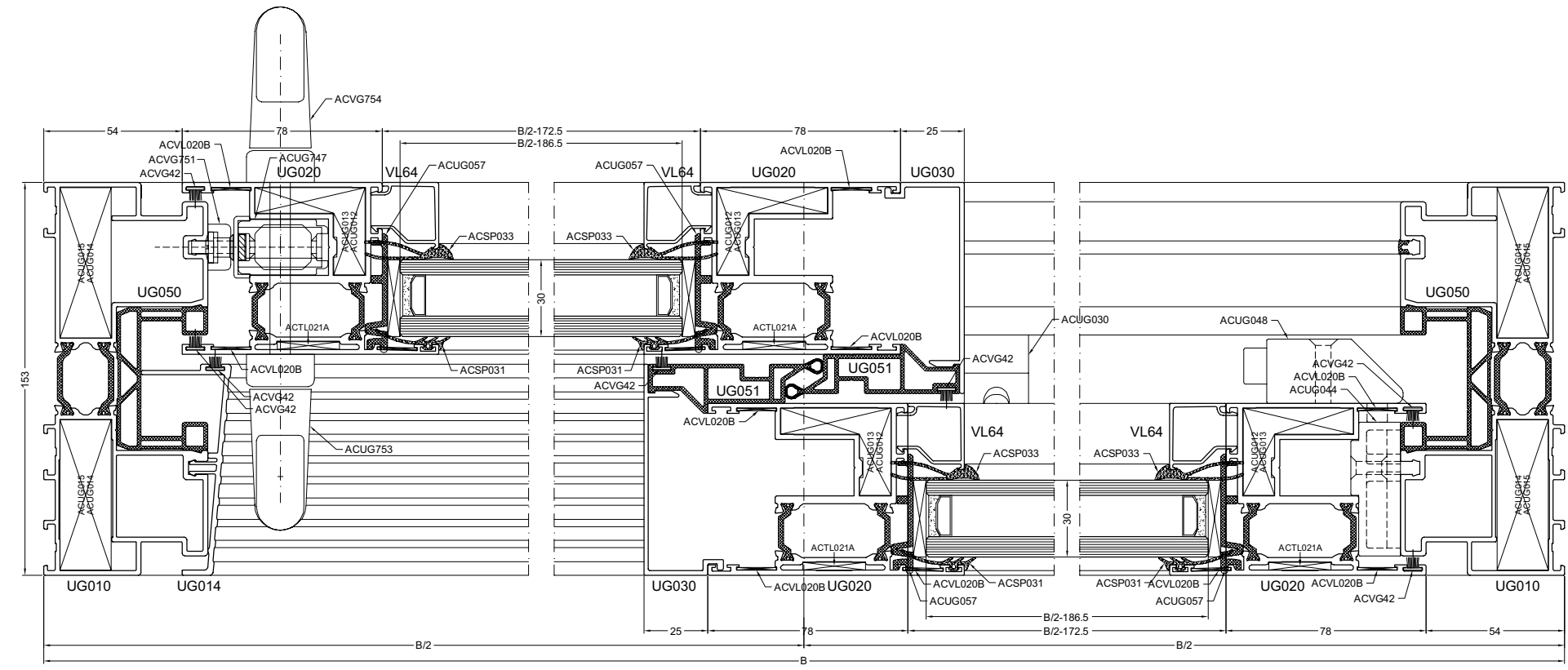
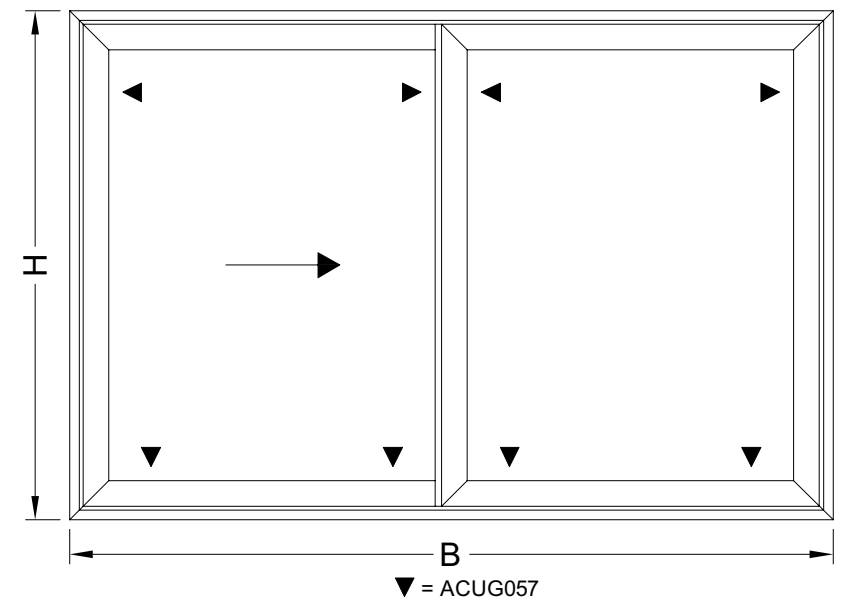

3 VLEUGELIG SCHUIFRAAM
FENETRE COULISSANTE 3 VANTAUX
SCHIEBEFENSTER 3 FLUGEL
SLIDING WINDOW WITH 3 PANELS

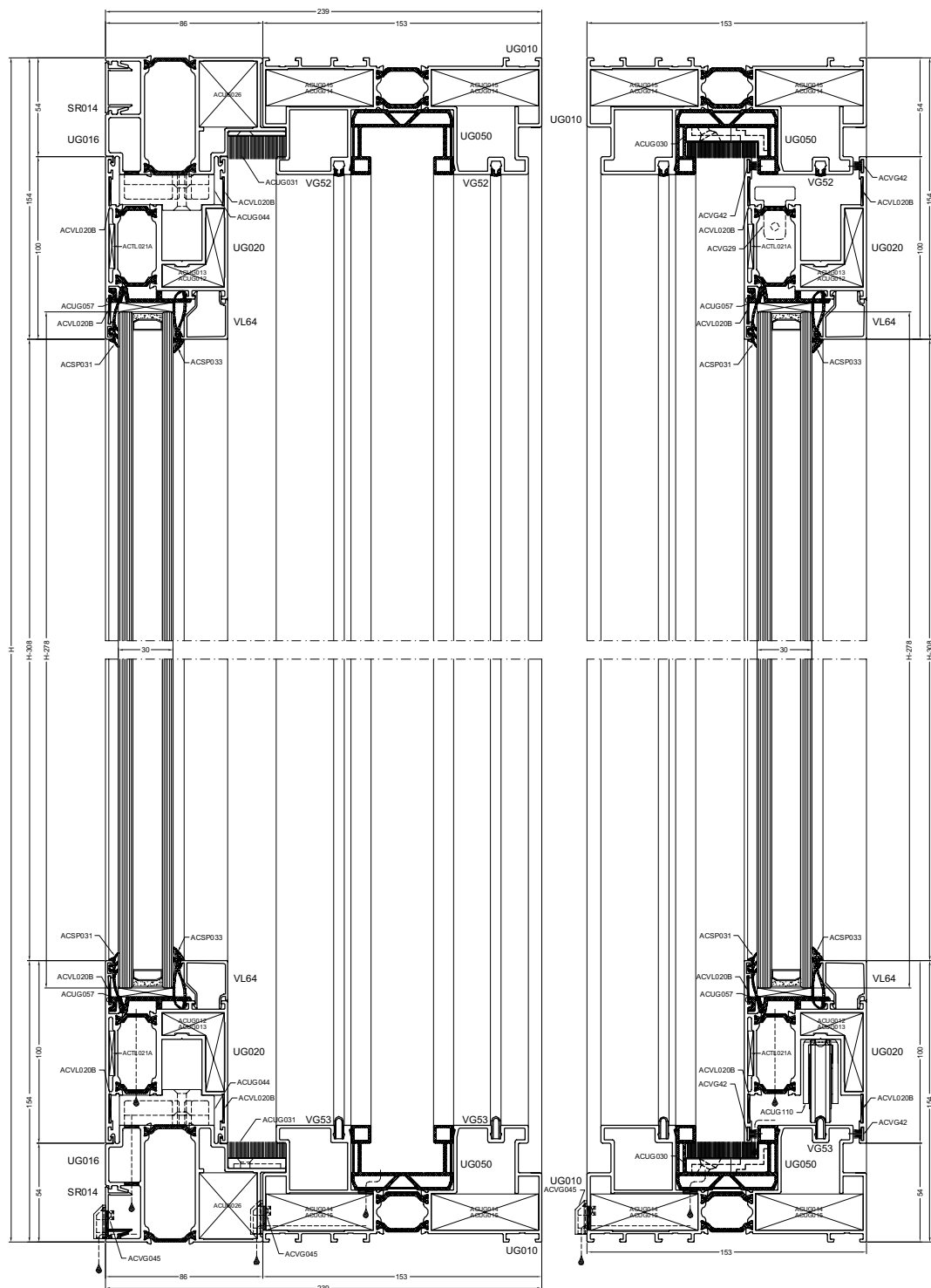

PROFIELEN / PROFILES / PROFILES / PROFILS

UG010		2		H
UG010		2		B
UG020		6		H-108
UG020		6		B/3+14
UG016		1		B/3+68
UG016		1		B/3+68
UG016		1		H
SR014		1		B/3+65.5
SR014		1		B/3+65.5
SR014		1		H-4.5
VL*		6		H-308
VL*		6		B/3-142
UG050		2		H-57
UG050		2		B-57
UG030		3		H-108
UG051		3		H-108
UG030		1		H-4
UG051		1		H-4
VG52		3		H-133
VG52		2		B-128
VG53		2		B-118

TOEBEHOREN / ACCESSOIRES
ZUBEHÖRTEILE / ACCESSORIES

ACUG014/015	8
ACUG026	2
ACUG012/013	12
ACTL021A	12
ACVL020B	36
ACUG057	12
ACUG030	1
ACUG031	1
ACUG48	2
ACVG45	4
ACVG29	2
ACUG120	3
ACUG110	4
ACUG040	1
ACUG044	5
ACUG746	5
ACUG747	4
ACVG751	1
ACVG754	1
ACUG753	1
ACMX01621	1
ACSP031	6H+2B-2300
ACSP033	6H+2B-2300
ACVG42	7H+5B-1400

GLASMATEN
DIMENSIONS DES VITRAGES
GLASSMASSE
GLASS SIZE

3X B/3-156
H-278

MAXIMAAL VLEUGELGEWICHT
POIDS MAXIMUM PAR VANTAIL
MAXIMAL FLUGELGEWICHT
MAX. WEIGHT OF THE VENT

250 KG

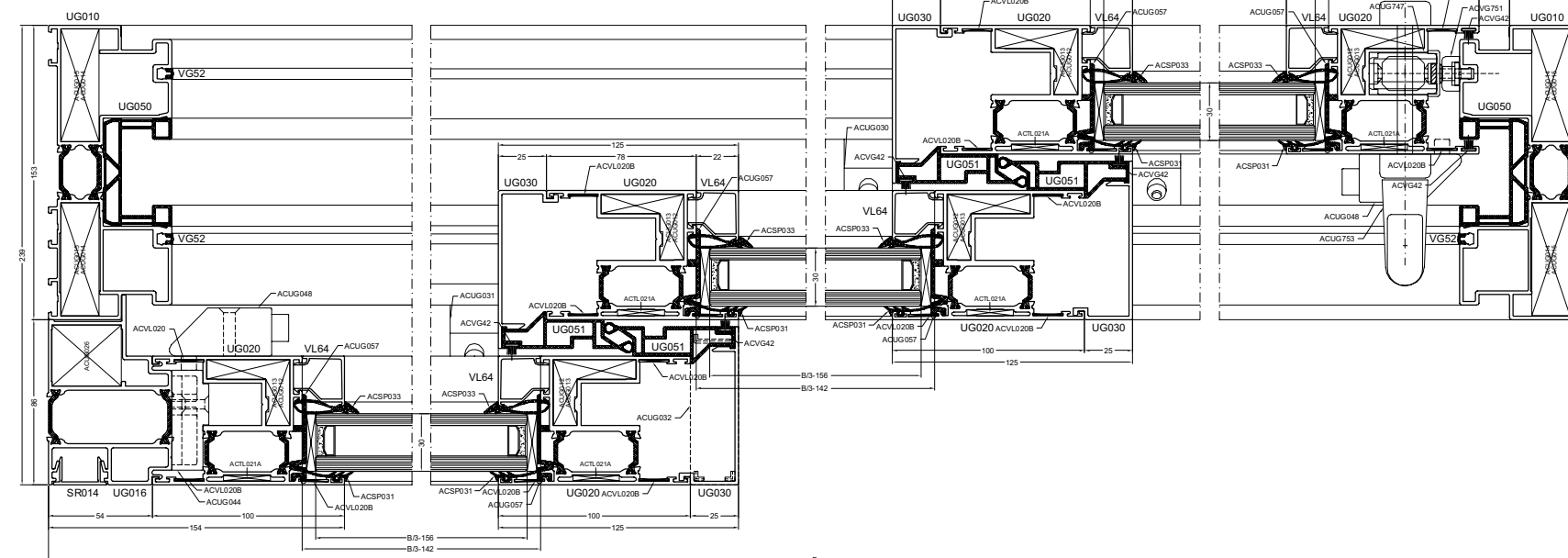
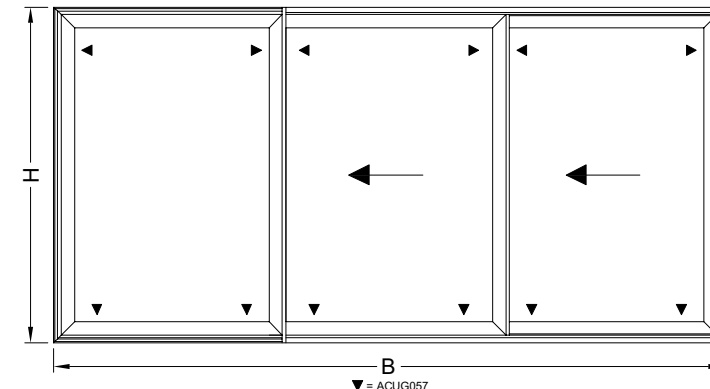

4 VLEUGELIG SCHUIFRAAM
FENETRE COULISSANTE 4 VANTAUX
SCHIEBEFENSTER 4 FLUGEL
SLIDING WINDOW WITH 4 PANELS

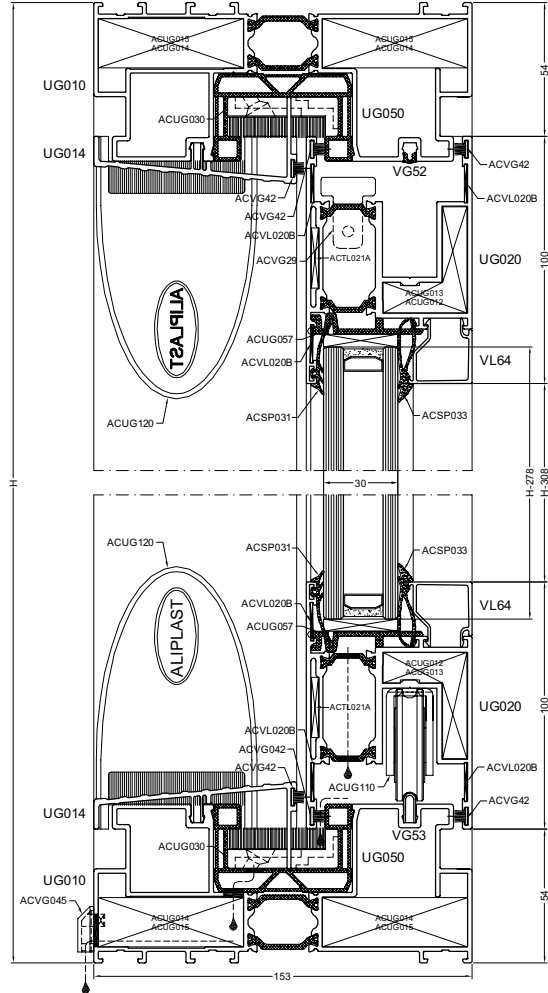

PROFIELEN / PROFILES / PROFILS / PROFILS			
UG010		2	H
UG010		2	B
UG020		8	H-108
UG020		8	B/4+8
VL*		4	H-308
VL*		4	B/4-148
UG050		2	H-57
UG050		2	B-57
UG030		4	H-108
UG051		4	H-108
UG140		1	H-160
UG014		2	B/2-174
VG52		2	H-133
VG52		1	B-128
VG53		1	B-118

GLASMATEN
 DIMENSIONS DES VITRAGES
 GLASMASSE
 GLASS SIZE

**4X B/4-162
 H-278**

MAXIMAAL VLEUGELGEWICHT
 POIDS MAXIMUM PAR VANTAIL
 MAXIMAL FLUGELGEWICHT
 MAX. WEIGHT OF THE VENT

250 KG

TOEBEHOREN / ACCESSOIRES ZUBEHÖRTEILE / ACCESSORIES	
ACUG014/015	8
ACUG012/013	16
ACTL021A	16
ACVL020B	48
ACUG057	16
ACUG044	10
ACUG030	2
ACUG028	1
ACSG080	1
ACSG081	1
ACUG48	2
ACVG45	4
ACVG29	2
ACUG120	2
ACUG110	4
ACUG040	1
ACUG746	5
ACUG747	4
ACVG751	1
ACVG754	1
ACUG753	1
ACVG762	1
ACVG763	1
ACMX01621	1
ACSP031	8H+4B-6400
ACSP033	8H+4B-6400
ACVG42	10H+6B-2400

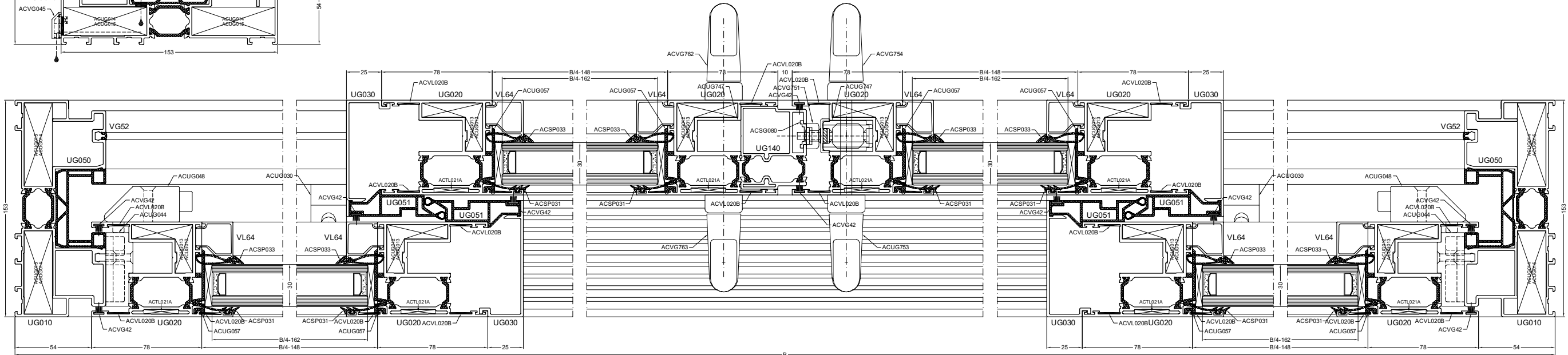
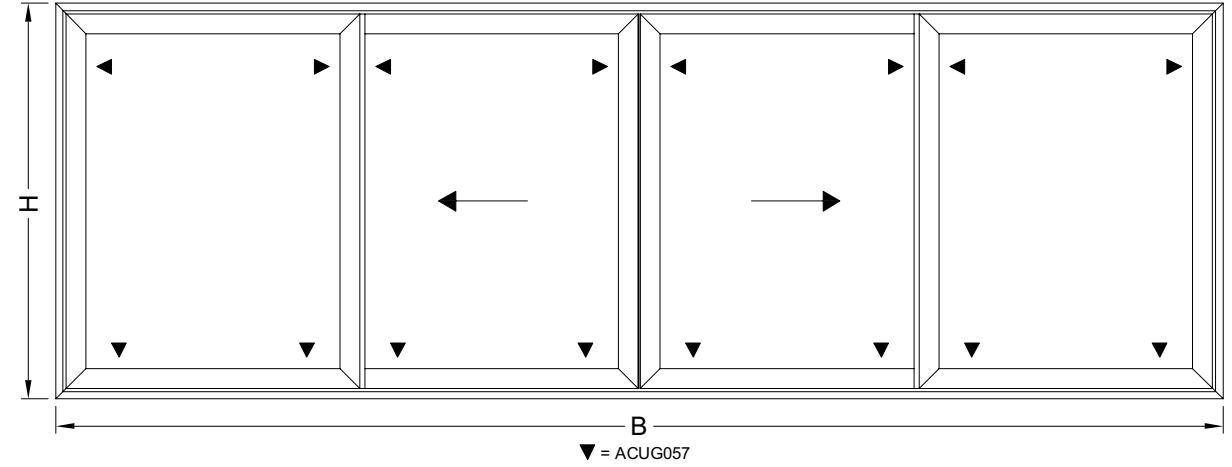

4 VLEUGELIG SCHUIFRAAM
FENETRE COULISSANTE 4 VANTAUX
SCHIEBEFENSTER 4 FLUGEL
SLIDING WINDOW WITH 4 PANELS

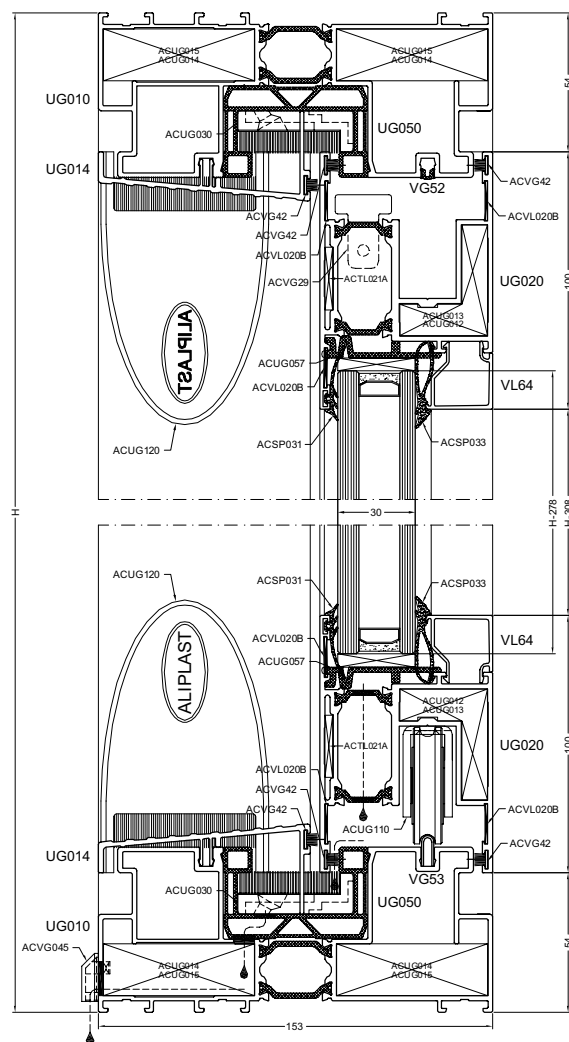

PROFIELEN / PROFILES / PROFILS / PROFILS

UG010		2	H
UG010		2	B
UG020		8	H-108
UG020		8	B/4+8
VL*		4	H-308
VL*		4	B/4-148
UG050		2	H-57
UG050		2	B-57
UG030		4	H-108
UG051		4	H-108
UG141		1	H-160
UG014		2	B/2-174
VG52		2	H-133
VG52		1	B-128
VG53		1	B-118

GLASMATEN
DIMENSIONS DES VITRAGES
GLASSASSE
GLASS SIZE

4X B/4-162
H-278

MAXIMAAL VLEUGELGEWICHT
POIDS MAXIMUM PAR VANTAIL
MAXIMAL FLUGELGEWICHT
MAX. WEIGHT OF THE VENT

250 KG

TOEBEHOREN / ACCESSOIRES
ZUBEHÖRTEILE / ACCESSORIES

ACUG014/015	8
ACUG012/013	16
ACTL021A	16
ACVL020B	48
ACUG057	16
ACUG044	10
ACUG030	2
ACUG128	1
ACUG48	2
ACVG45	4
ACVG29	2
ACUG120	2
ACUG110	4
ACUG040	1
ACUG746	5
ACUG747	4
ACVG751	1
ACVG754	1
ACUG753	1
ACVG762	1
ACVG763	1
ACMX01621	1
ACSP031	8H+4B-6400
ACSP033	8H+4B-6400
ACVG42	10H+6B-2400

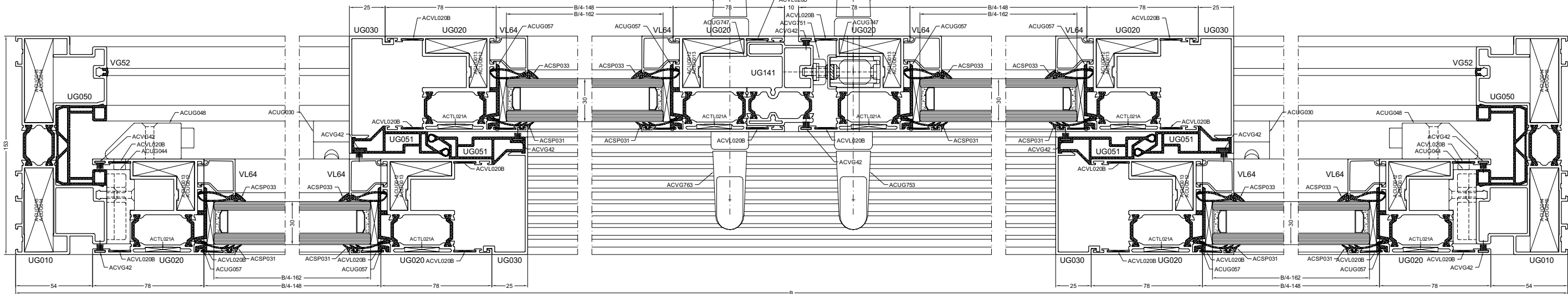
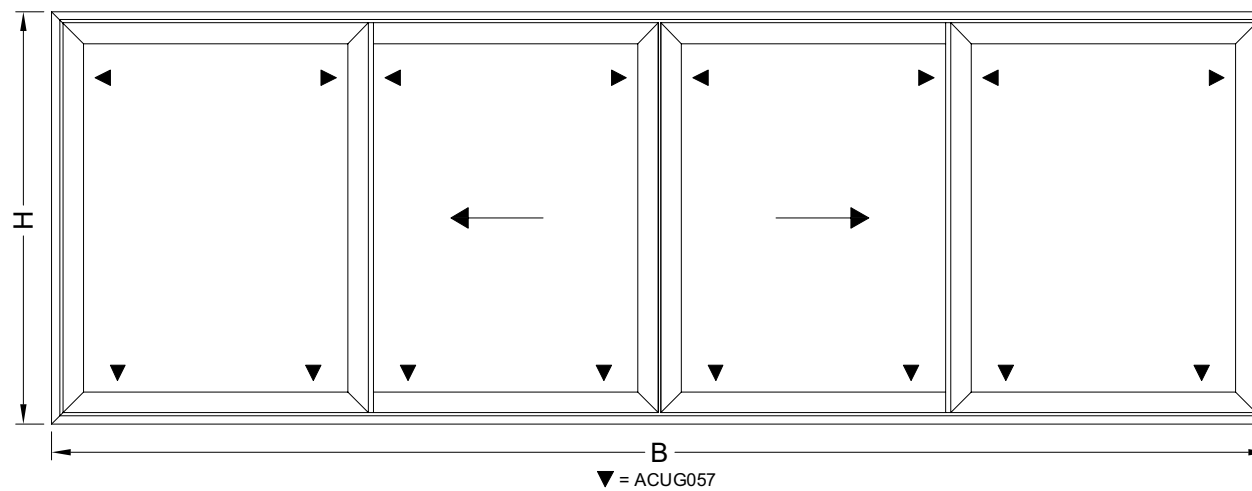

zaag5



ZAAGTABELLEN - TABLES DE SCIAGES - ZUSCHNITT-TABELLEN - SAWING TABLES

2 VLEUGELIG HEFSCHUIFRAAM
FENETRE LEVANT COULISSANTE 2 VANTAUX
HEBESCHIEBEFENSTER 2 FLUGEL
DOUBLE LIFT SLIDING PATIODOOR

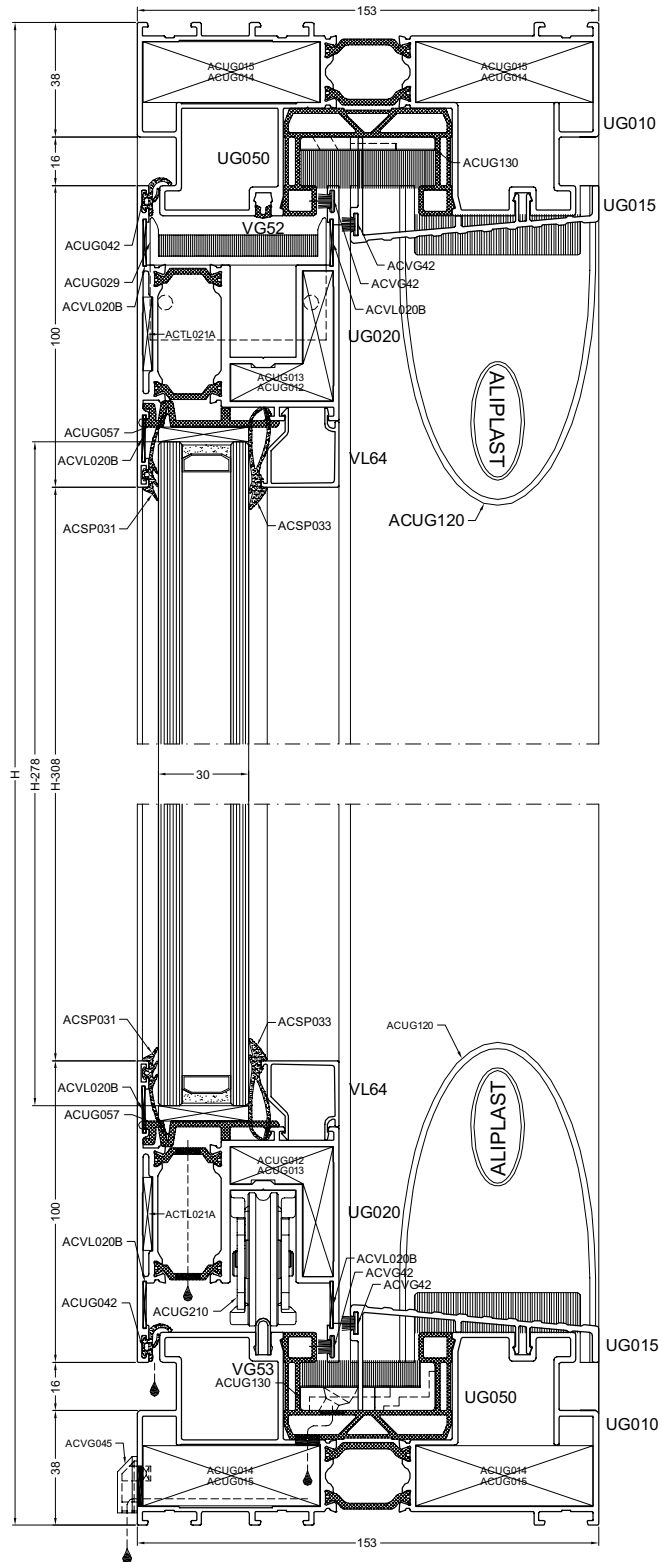

PROFIELEN / PROFILES / PROFILS / PROFILS

UG010		2	H
UG010		2	B
UG020		4	H-108
UG020		4	B/2-16.5
VL*		4	H-308
VL*		4	B/2-172.5
UG050		2	H-57
UG050		2	B-57
UG030		2	H-108
UG051		2	H-108
UG015		1	H-76
UG015		2	B-100.5
VG52		1	H-133
VG52		1	B-128
VG53		1	B-118

GLASMATEN
DIMENSIONS DES VITRAGES
GLASSMASSE
GLASS SIZE

2X B/2-186.5
H-278

MAXIMAAL VLEUGELGEWICHT
POIDS MAXIMUM PAR VANTAIL
MAXIMAL FLUGELGEWICHT
MAX. WEIGHT OF THE VENT

300 KG

**TOEBEHOREN / ACCESSOIRES
ZUBEHÖRTEILE / ACCESSOIRES**

ACUG014/015	8
ACUG012/013	8
ACTL021A	8
ACVL020B	24
ACUG057	8
ACUG044	5
ACUG130	1
ACUG48	1
ACVG45	2
ACUG029	2
ACUG120	2
ACSP031	4H+2B-1600
ACSP033	4H+2B-1600
ACVG42	5H+2B-600
ACUG042	3B-2H-300
ACMX01603	1
ACUG210	1
ACUG288	1
ACUG23*	B/2-732.5

**VLEUGELBREEDTE / LARGEUR VANTAIL
BREITE FLUGEL / WIDTH SASH**

894 mm - 1574 mm	ACUG230	1
1575 mm - 2074 mm	ACUG231	
2075 mm - 2574 mm	ACUG232	
2464 mm - 3314 mm	ACUG233	

ACUG20* H-250

**VLEUGELHOOGTE / HAUTEUR D'OUVRANT
FLUGEL HOHE / VENT HEIGHT**

1643 mm - 1942 mm	ACUG200	1
1943 mm - 2242 mm	ACUG201	
2243 mm - 2542 mm	ACUG202	
2543 mm - 2842 mm	ACUG203	

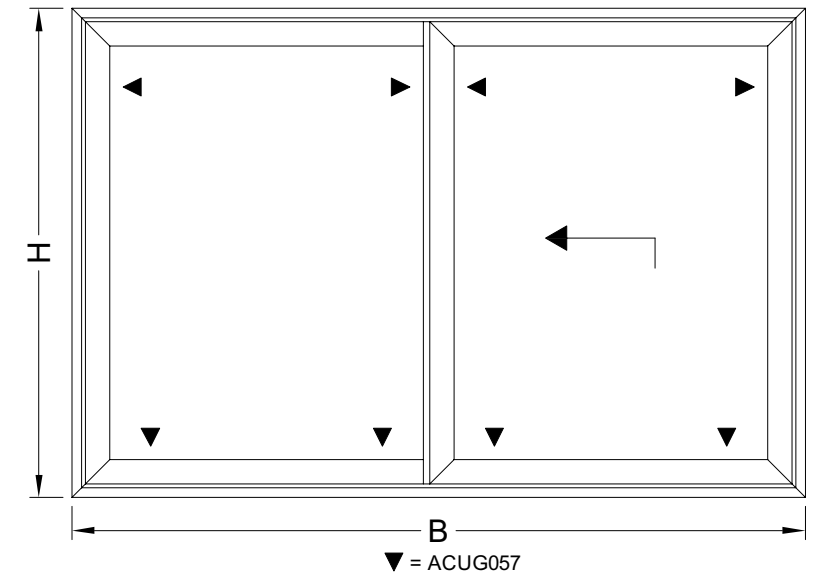

VLEUGELBREEDTE
LARGEUR VANTAIL
BREITE FLUGEL
WIDTH SASH
B/2-16.5

VLEUGELHOOGTE
HAUTEUR D'OUVRANT
FLUGEL HOHE
VENT HEIGHT
H-108

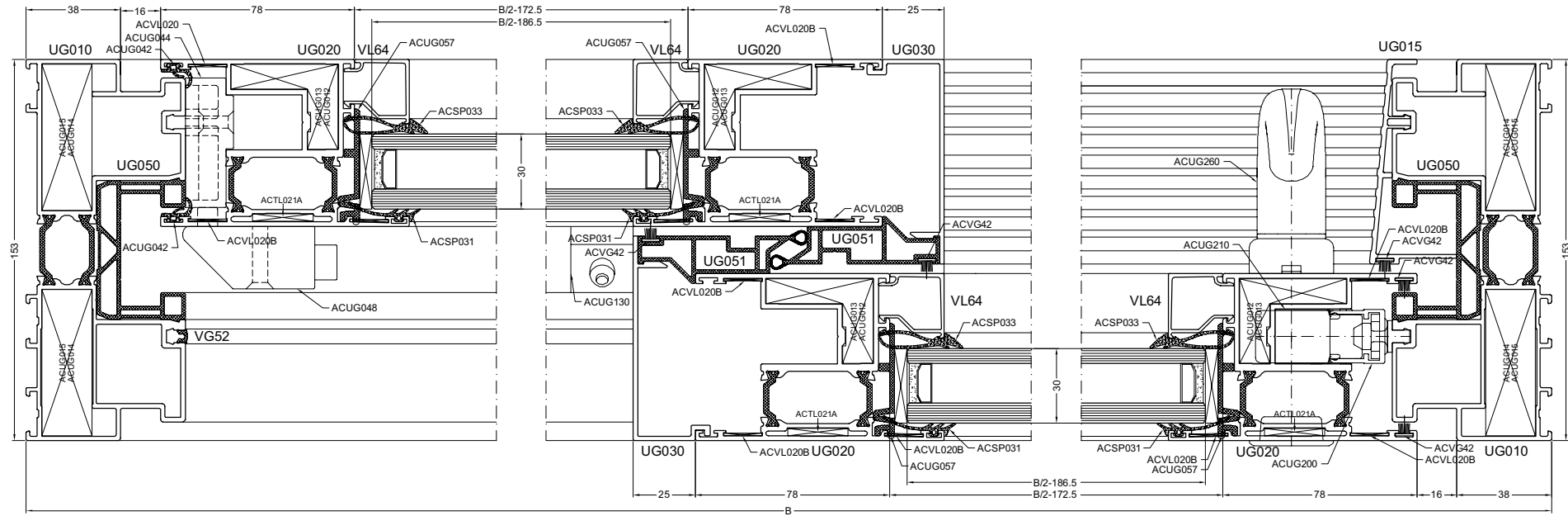

zaag7

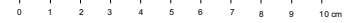

4 VLEUGELIG HEFSCHUIFRAAM
FENETRE LEVANT COULISSANTE 4 VANTAUX
HEBESCHIEBEFENSTER 4 FLUGEL
LIFT SLIDING PATIODOOR WITH 4 PANELS

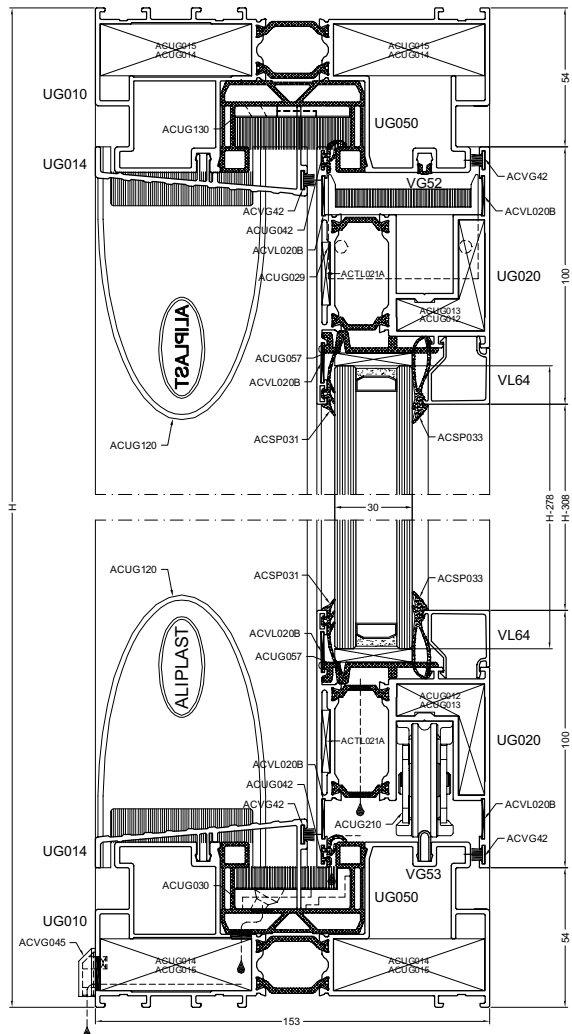

PROFIELEN / PROFILES / PROFILES / PROFILS

UG010		2		H
UG010		2		B
UG020		8		H-108
UG020		8		B/4+8
VL*		4		H-308
VL*		4		B/4-148
UG050		2		H-57
UG050		2		B-57
UG030		4		H-108
UG051		4		H-108
UG141		1		H-160
UG014		2		B/2-174
VG52		2		H-133
VG52		1		B-128
VG53		1		B-118

GLASMATEN
 DIMENSIONS DES VITRAGES
 GLASSMASSE
 GLASS SIZE

4X B/4-162
 H-278

MAXIMAAL VLEUGELGEWICHT
 POIDS MAXIMUM PAR VANTAIL
 MAXIMAL FLUGELGEWICHT
 MAX. WEIGHT OF THE VENT

300 KG

**TOEBEHOREN / ACCESSOIRES
 ZUBEHORTEILE / ACCESSORIES**

ACUG014/015	8
ACUG012/013	16
ACTL021A	16
ACVL020B	48
ACUG057	16
ACUG044	10
ACUG130	2
ACUG48	2
ACVG45	4
ACUG029	4
ACUG120	4
ACSP031	8H+4B-6400
ACSP033	8H+4B-6400
ACVG42	6H+2B-950
ACUG042	4H+3B-300
ACMX01603	2
ACUG210	2
ACUG288	2
ACUG221	1
ACUG23*	B/4-708

**VLEUGELBREEDTE / LARGEUR VANTAIL
 BREITE FLUGEL / WIDTH SASH**

894 mm - 1574 mm	ACUG230	2
1575 mm - 2074 mm	ACUG231	
2075 mm - 2574 mm	ACUG232	
2464 mm - 3314 mm	ACUG233	

**VLEUGELHOOGTE / HAUTEUR D'OUVRANT
 FLUGEL HOHE / VENT HEIGHT**

1643 mm - 1942 mm	ACUG200	2
1943 mm - 2242 mm	ACUG201	
2243 mm - 2542 mm	ACUG202	
2543 mm - 2842 mm	ACUG203	

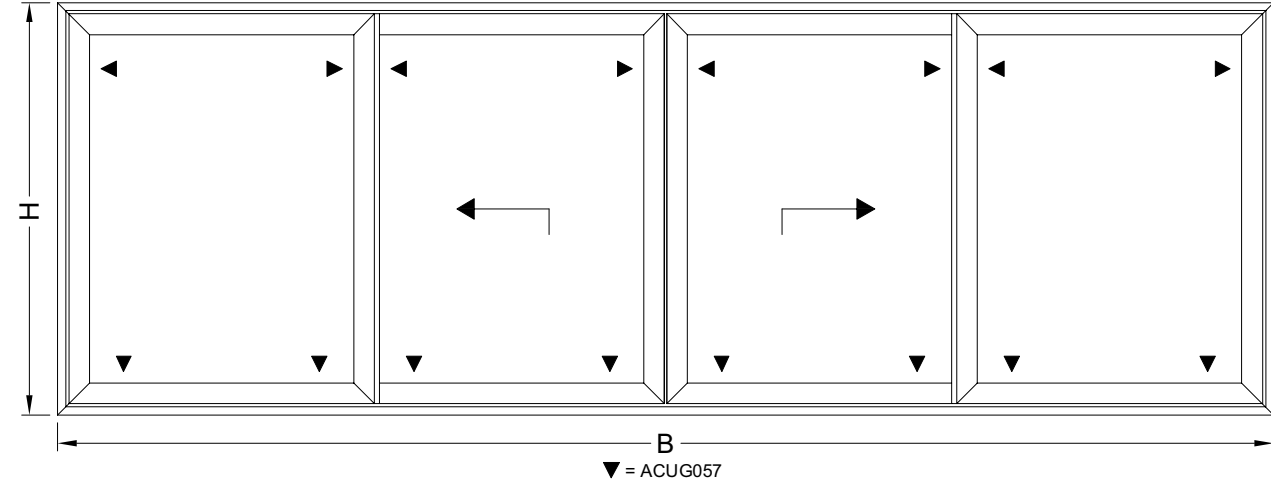

**VLEUGELBREEDTE
 LARGEUR VANTAIL
 BREITE FLUGEL
 WIDTH SASH** B/4+8

**VLEUGELHOOGTE
 HAUTEUR D'OUVRANT
 FLUGEL HOHE
 VENT HEIGHT** H-108

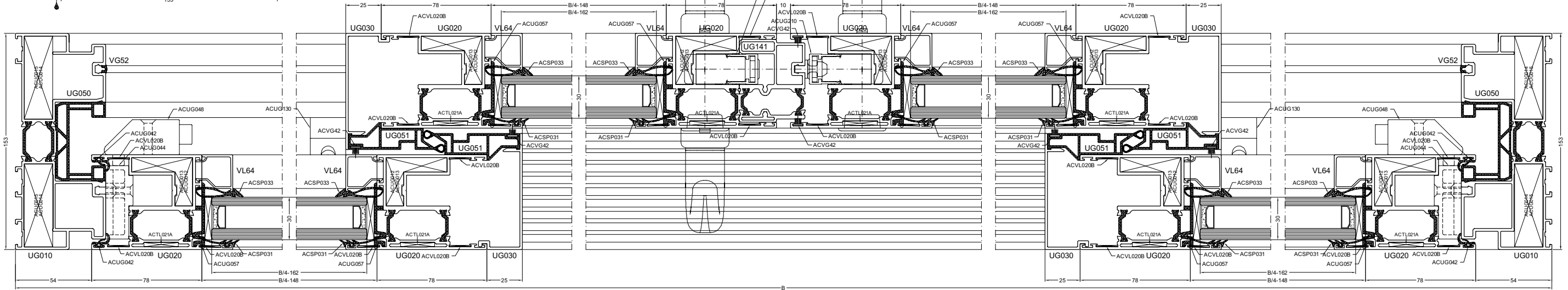

ZAAGTABELLEN - TABLES DE SCIAGES - ZUSCHNITT-TABELLEN - SAWING TABLES

zaag8

MONTAGE SCHROEFHOEK VOOR UG010
 MONTAGE CLAME A VISSER POUR UG010
 MONTAGE ECKVERBINDER SCHRAUBBAR FÜR UG010
 MONTAGE SQUARE COUPLING JOINT FOR UG010

1. Ontvetten van zaagsnede
 Degraisser les coupes
 Entfetten der Sageschnitt
 Degrease saw cut
2. Afkitten met ACSIL04
 Colmater avec ACSIL04
 Abdichten mit ACSIL04
 Seal with ACSIL04
3. Lijmen in profiel met ACSIL013 (met pistool ACSIL08)
 Colle ACSIL013 a mettre dans les chambres (pistolet ACSIL08)
 ACSIL013 Klebstoff im Profil (Kleberpistol ACSIL08)
 ACSIL013 glue in profile (pistol ACSIL08)
4. Blokjes vastdraaien met ACVG66
 Serrer les clames avec ACVG66
 Festsetzen der Eckverbinder mit ACVG66
 Fixe the cleat corner with ACVG66

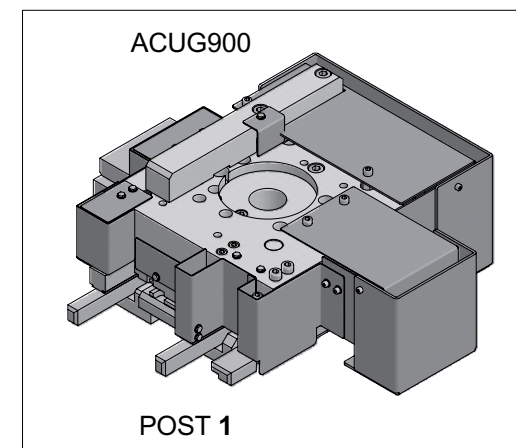
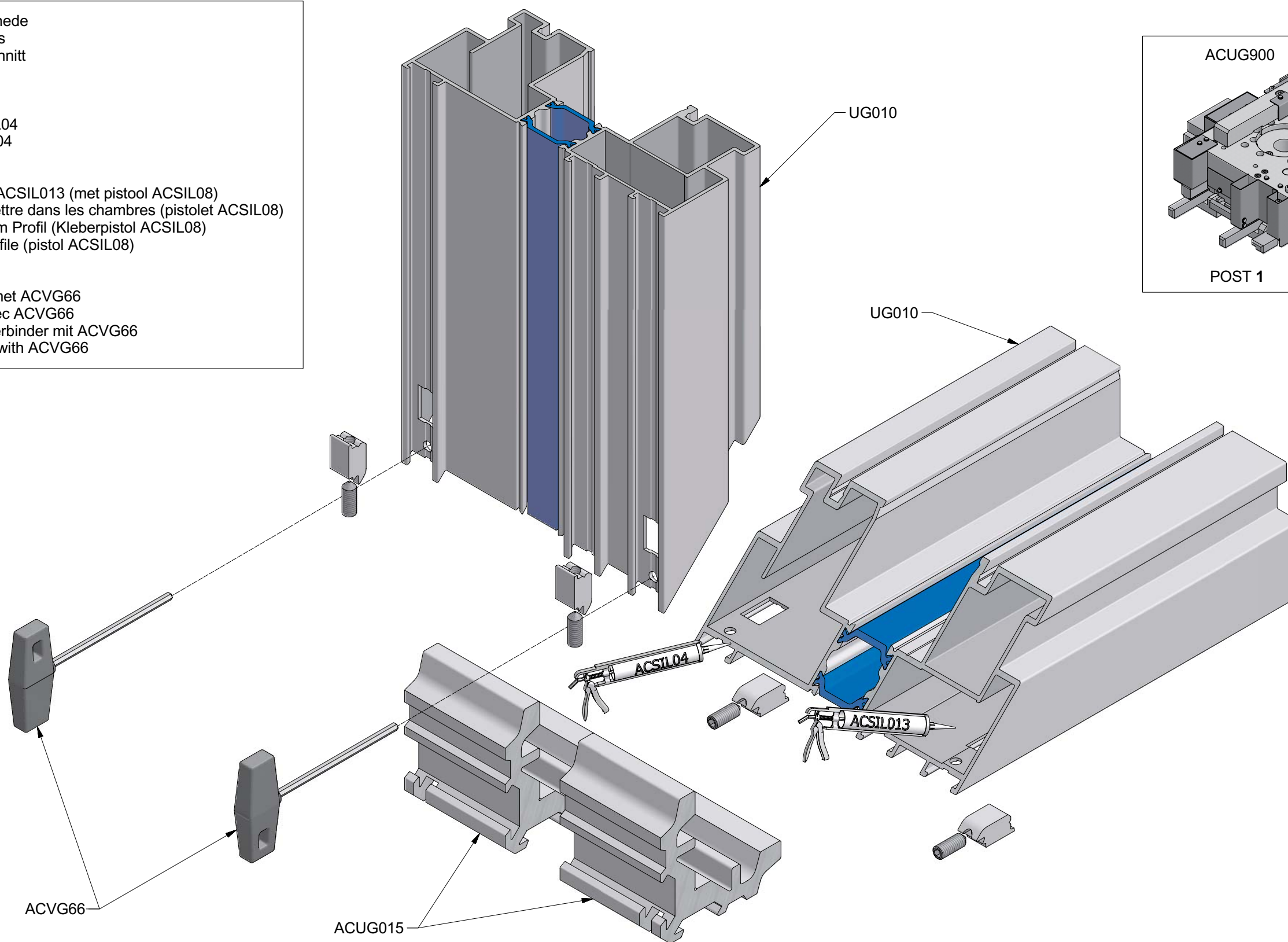

MONTAGE SCHROEFHOEK UG010.idw

MONTAGE SCHROEFHOEK VOOR UG011
 MONTAGE CLAME A VISSER POUR UG011
 MONTAGE ECKVERBINDER SCHRAUBBAR FÜR UG011
 MONTAGE SQUARE COUPLING JOINT FOR UG011

1. Ontvetten van zaagsnede
 Degraisser les coupes
 Entfetten der Sageschnitt
 Degrease saw cut
2. Afkitten met ACSIL04
 Colmater avec ACSIL04
 Abdichten mit ACSIL04
 Seal with ACSIL04
3. Lijmen in profiel met ACSIL013 (met pistool ACSIL08)
 Colle ACSIL013 a mettre dans les chambres (pistolet ACSIL08)
 ACSIL013 Klebstoff im Profil (Kleberpistol ACSIL08)
 ACSIL013 glue in profile (pistol ACSIL08)
4. Blokjes vastdraaien met ACVG66
 Serrer les clames avec ACVG66
 Festsetzen der Eckverbinder mit ACVG66
 Fixe the cleat corner with ACVG66

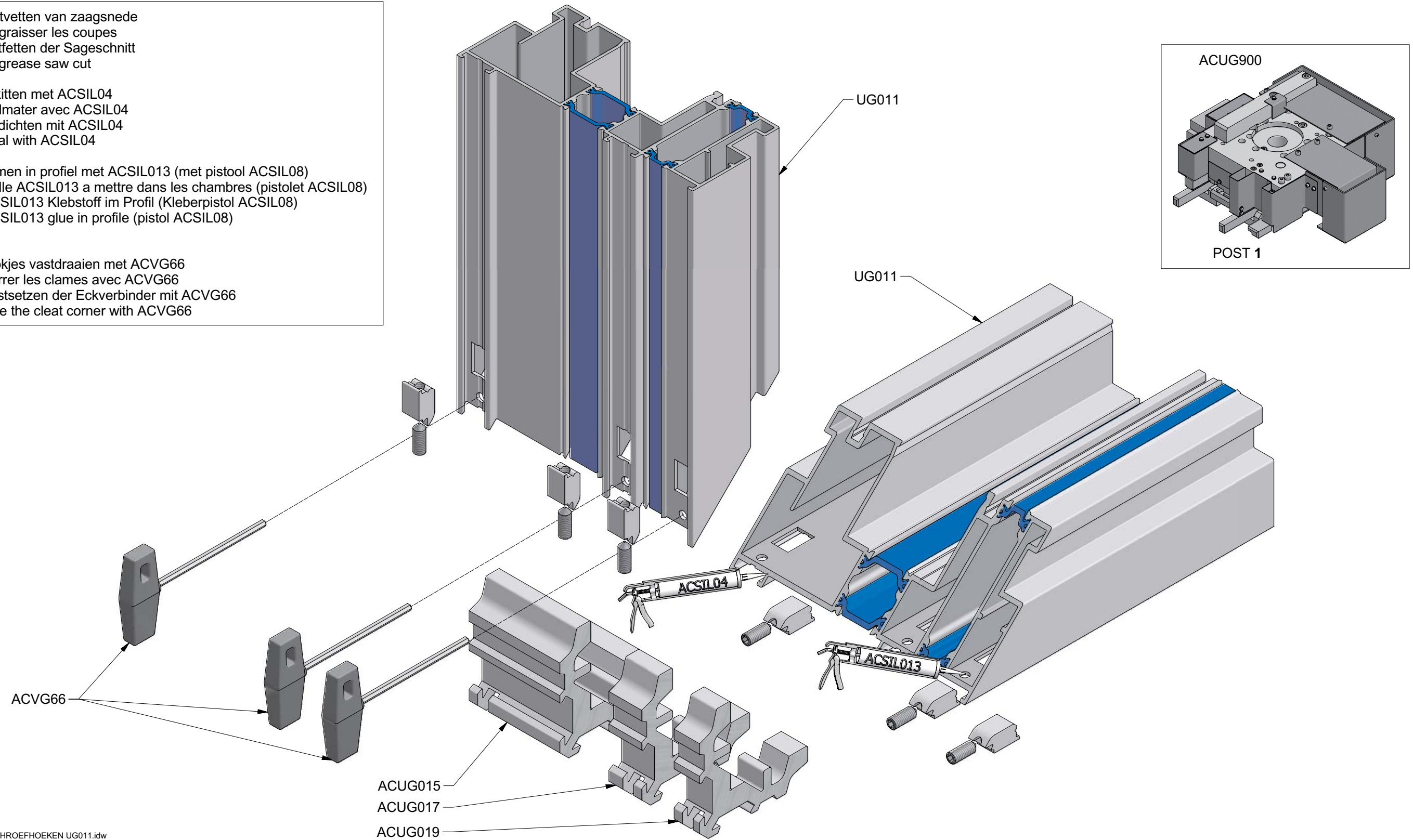

MONTAGE SCHROEFHOEKEN UG011.idw

MONTAGE SCHROEFHOEK VOOR UG610
 MONTAGE CLAME A VISSER POUR UG610
 MONTAGE ECKVERBINDER SCHRAUBBAR FÜR UG610
 MONTAGE SQUARE COUPLING JOINT FOR UG610

1. Ontvetten van zaagsnede
 Degraisser les coupes
 Entfetten der Sageschnitt
 Degrease saw cut
2. Afkitten met ACSIL04
 Colmater avec ACSIL04
 Abdichten mit ACSIL04
 Seal with ACSIL04
3. Lijmen in profiel met ACSIL013 (met pistool ACSIL08)
 Colle ACSIL013 a mettre dans les chambres (pistolet ACSIL08)
 ACSIL013 Klebstoff im Profil (Kleberpistol ACSIL08)
 ACSIL013 glue in profile (pistol ACSIL08)
4. Blokjes vastdraaien met ACVG66
 Serrer les clames avec ACVG66
 Festsetzen der Eckverbinder mit ACVG66
 Fixe the cleat corner with ACVG66

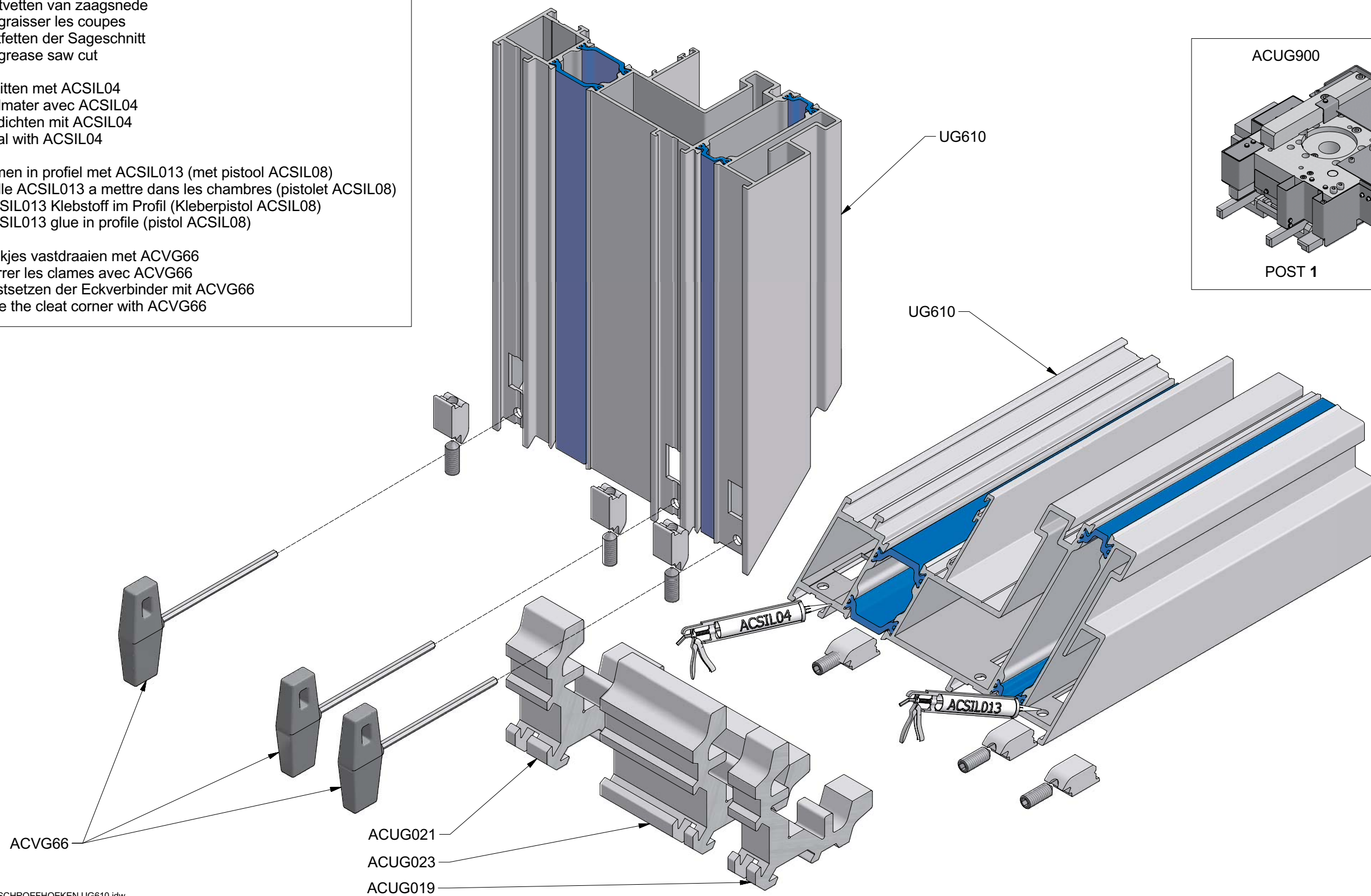

MONTAGE SCHROEFHOEKEN UG610.idw

MONTAGE HOEKVERBINDERS VOOR UG020
 MONTAGE CLAMES POUR UG020
 MONTAGE ECKVERBINDERS FÜR UG020
 MONTAGE CORNERS FOR UG020

1. Ontvetten van zaagsnede
 Degraisser les coupes
 Entfetten der Sageschnitt
 Degrease saw cut
2. Afkitten met ACSIL04
 Colmater avec ACSIL04
 Abdichten mit ACSIL04
 Seal with ACSIL04
3. Lijmen in profiel met ACSIL013 (met pistool ACSIL08)
 Colle ACSIL013 a mettre dans les chambres (pistolet ACSIL08)
 ACSIL013 Klebstoff im Profil (Kleberpistol ACSIL08)
 ACSIL013 glue in profile (pistol ACSIL08)
4. Blokjes vastdraaien met ACVG66
 Serrer les clames avec ACVG66
 Festsetzen der Eckverbinder mit ACVG66
 Fixe the cleat corner with ACVG66

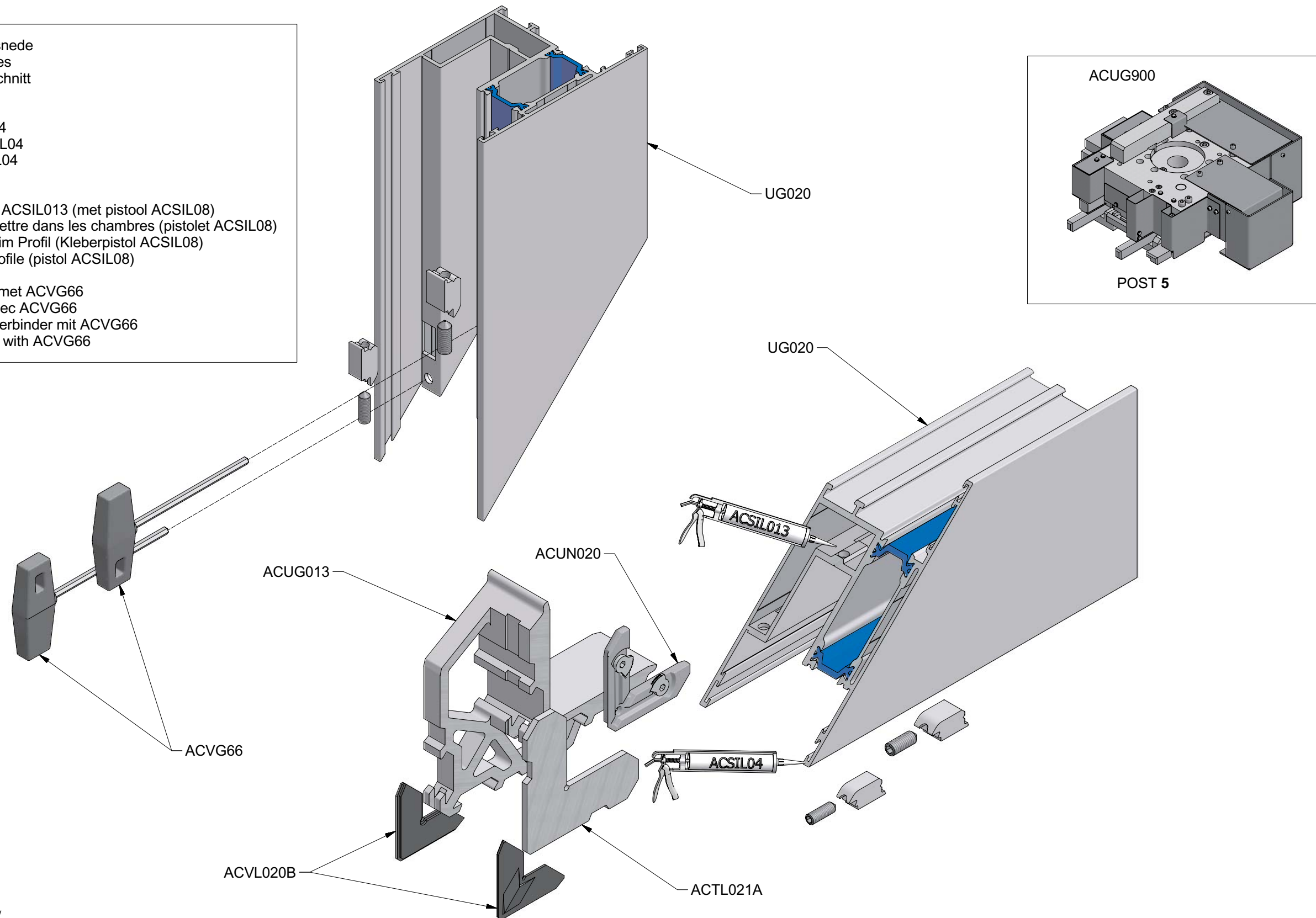

MONTAGE HOEKVERBINDERS UG020.idw

MONTAGE ACUN020
MONTAGE ACUN020
MONTAGE ACUN020
MONTAGE ACUN020

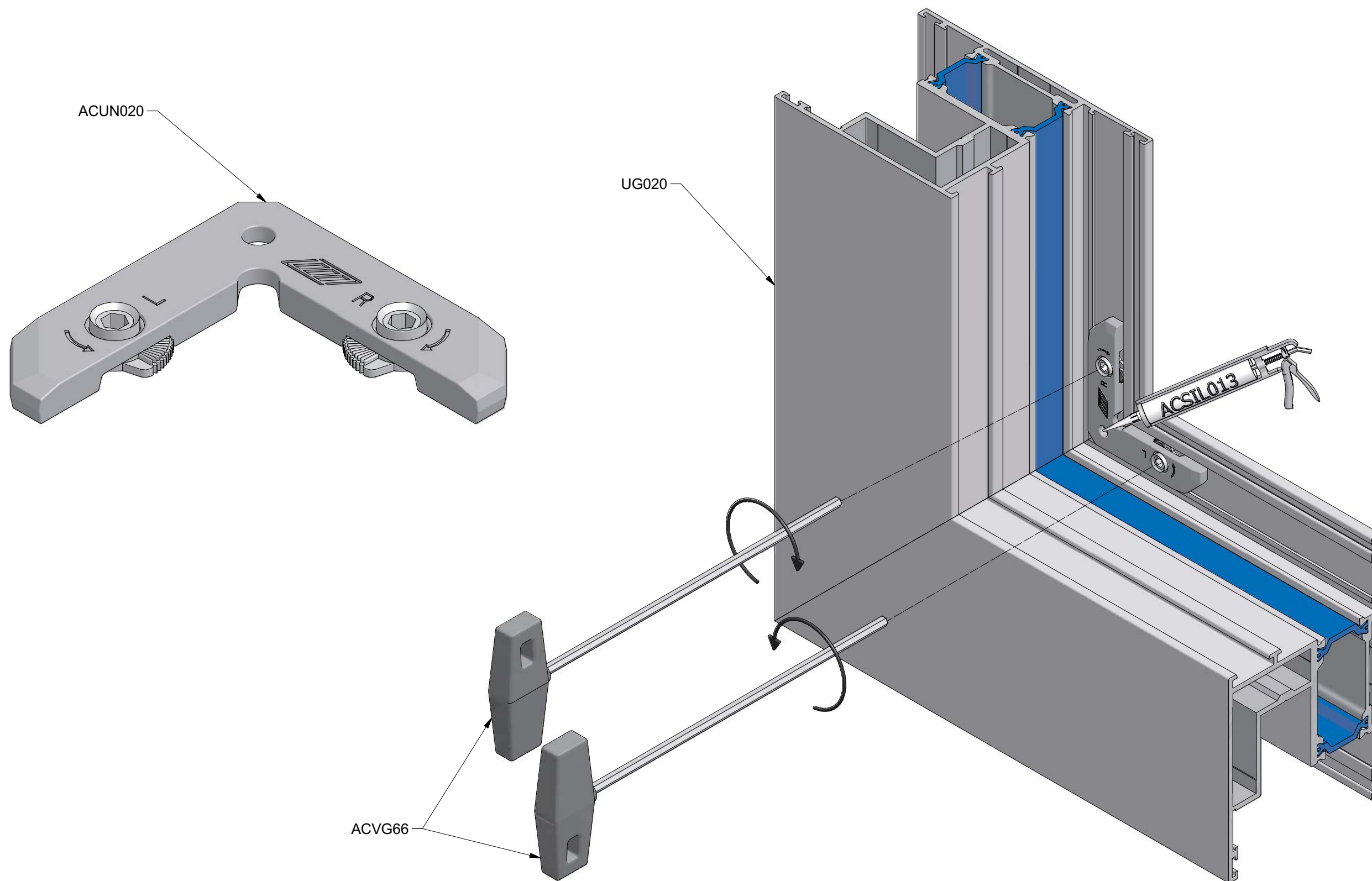

MONTAGE ACUN020.idw

MONTAGE MONORAIL
MONTAGE MONORAIL
MONTAGE MONORAIL
MONTAGE MONORAIL

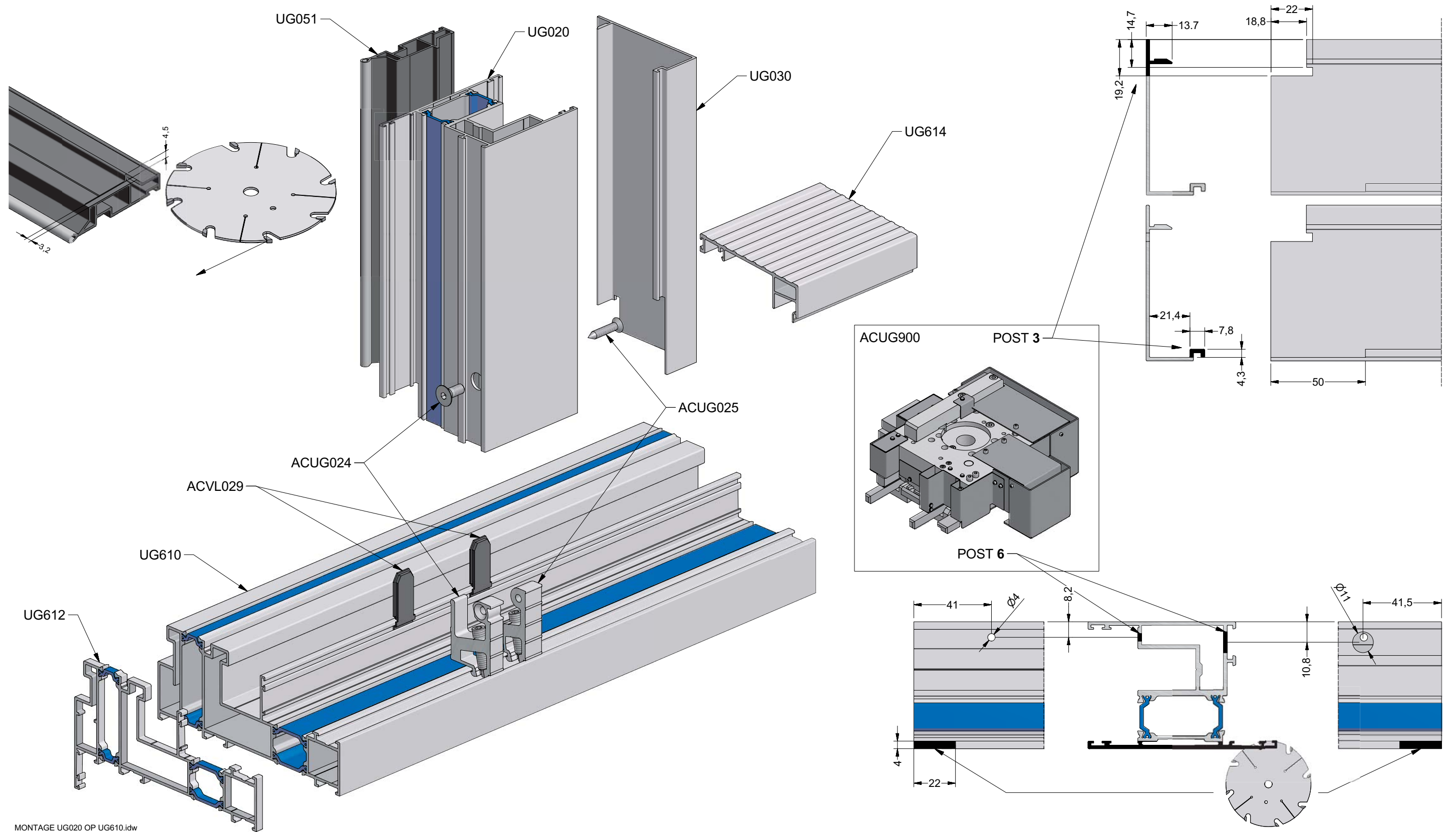

MONTAGE UG020 OP UG610.idw

MONTAGE TUSSENREGELS
 MONTAGE TRAVERSES
 MONTAGE SPROSSENPROFILE
 MONTAGE TRANSOMS

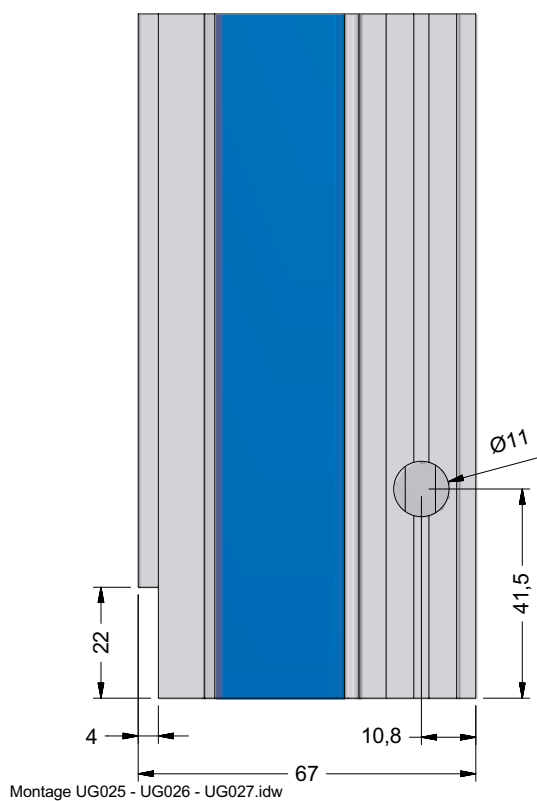
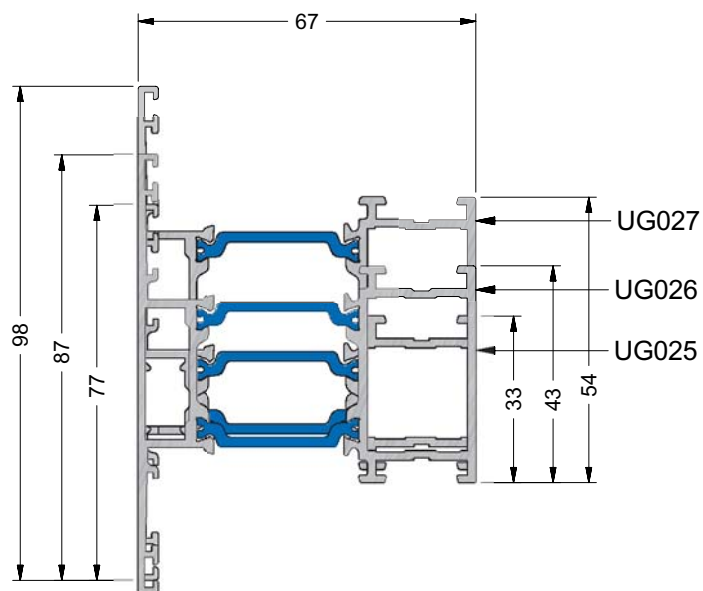

Montage UG025 - UG026 - UG027.idw

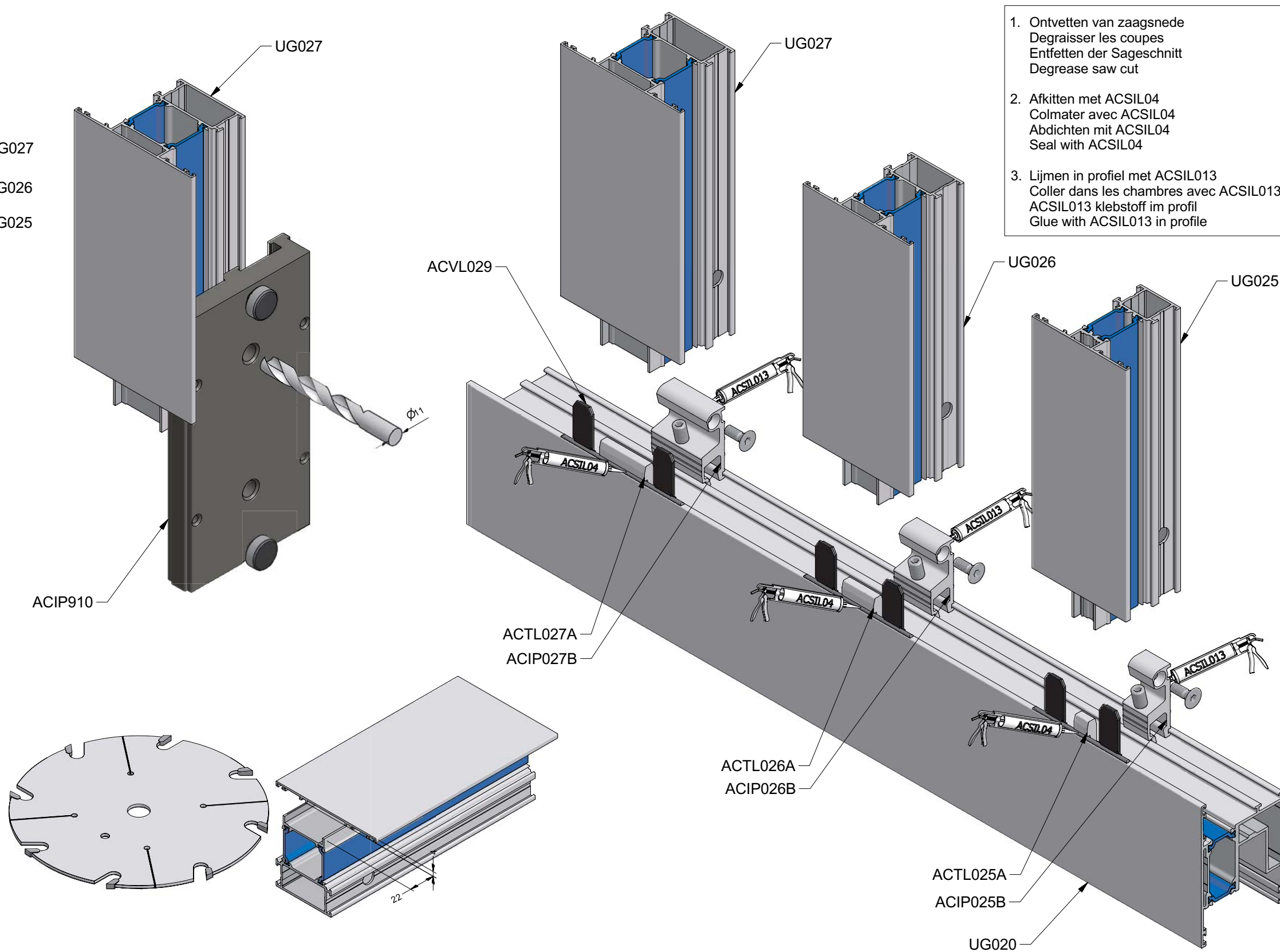

1. Ontvetten van zaagsnede
 Degraisser les coupes
 Entfetten der Sageschnitt
 Degrease saw cut
2. Afkitten met ACSIL04
 Colmater avec ACSIL04
 Abdichten mit ACSIL04
 Seal with ACSIL04
3. Lijmen in profiel met ACSIL013
 Coller dans les chambres avec ACSIL013
 ACSIL013 klebstoff im profil
 Glue with ACSIL013 in profile

WERKTEKENINGEN - DESSINS DE CONSTRUCTION - KONSTRUKTIONZEICHNUNGEN - CONSTRUCTION DRAWINGS

MONTAGE UG031
MONTAGE UG031
MONTAGE UG031
MONTAGE UG031

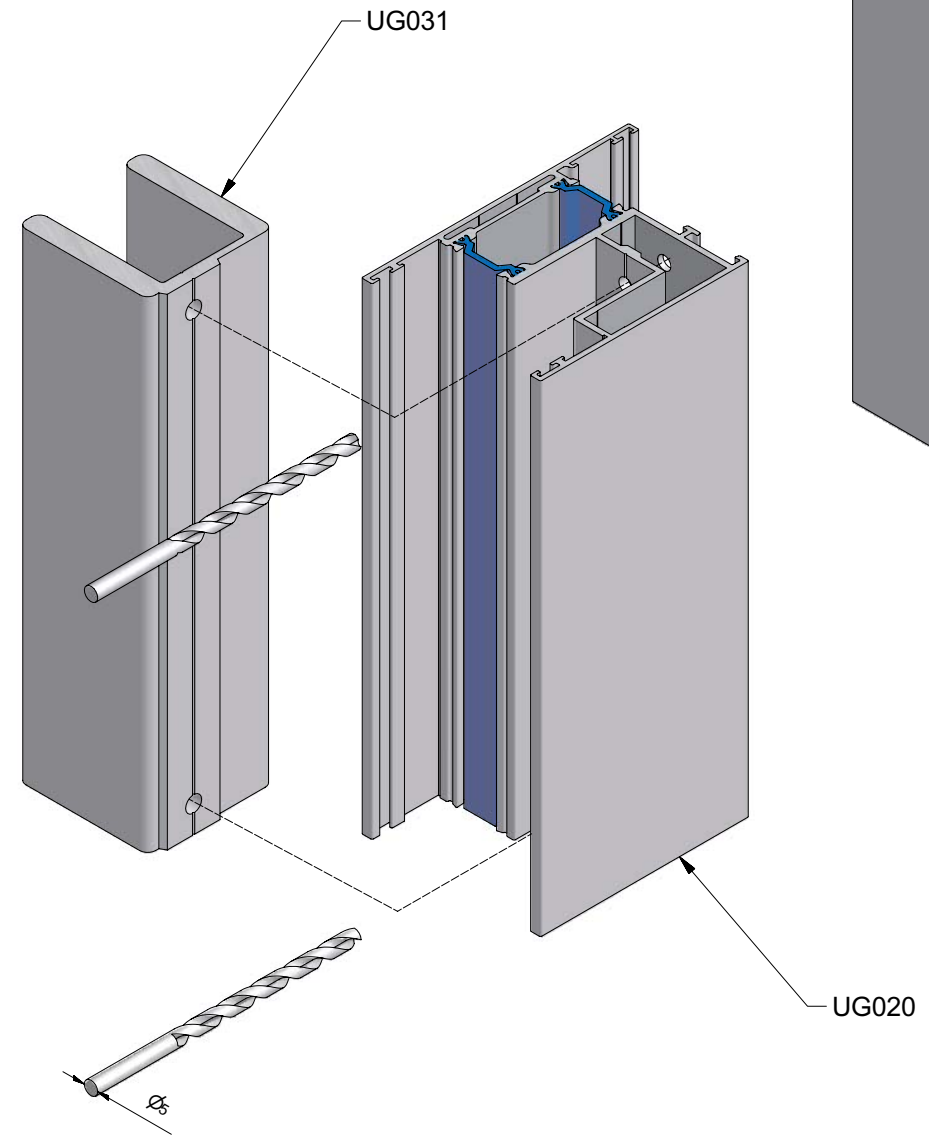
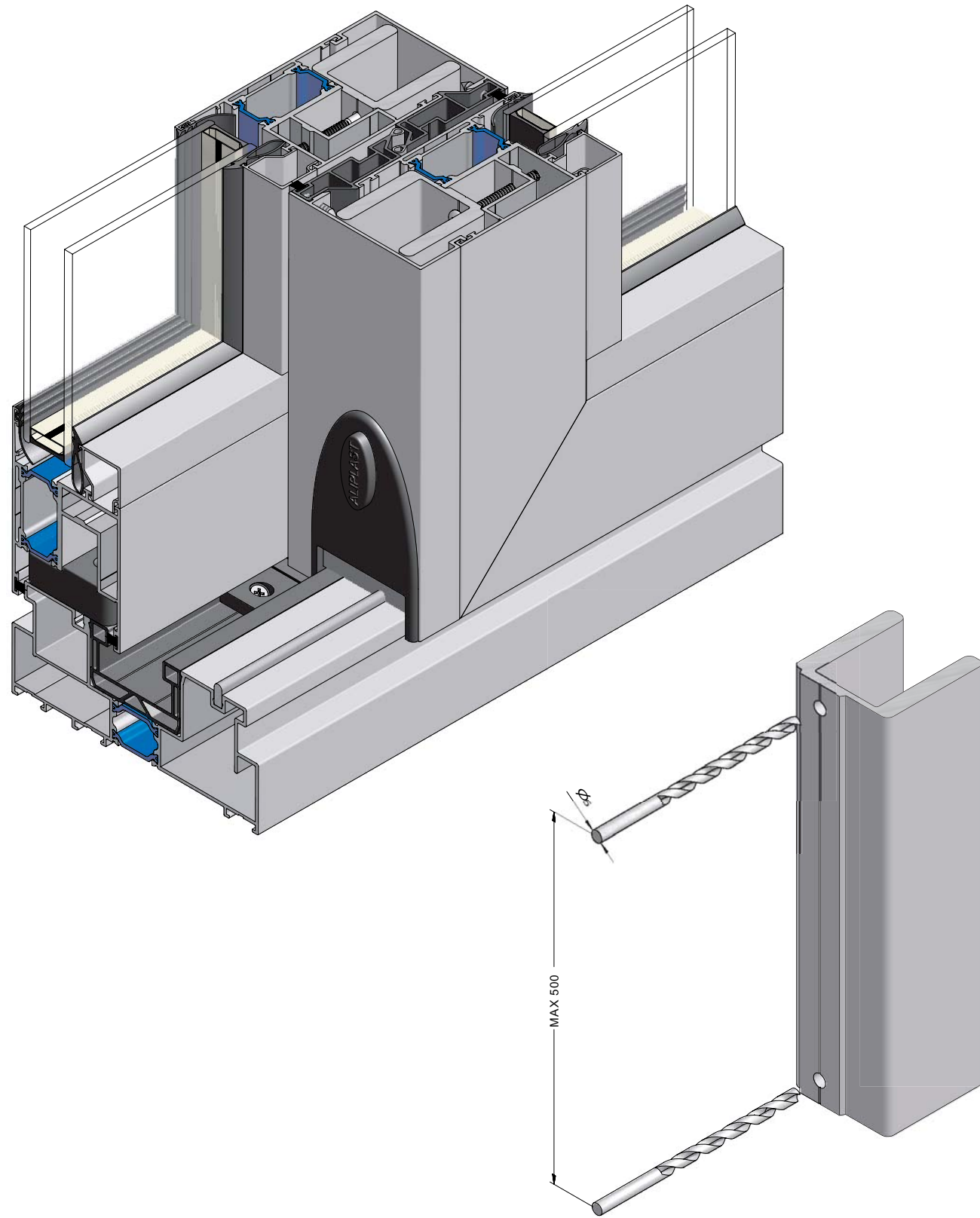

MONTAGE UG031.idw

MONTAGE ACUG028
MONTAGE ACUG028
MONTAGE ACUG028
MONTAGE ACUG028

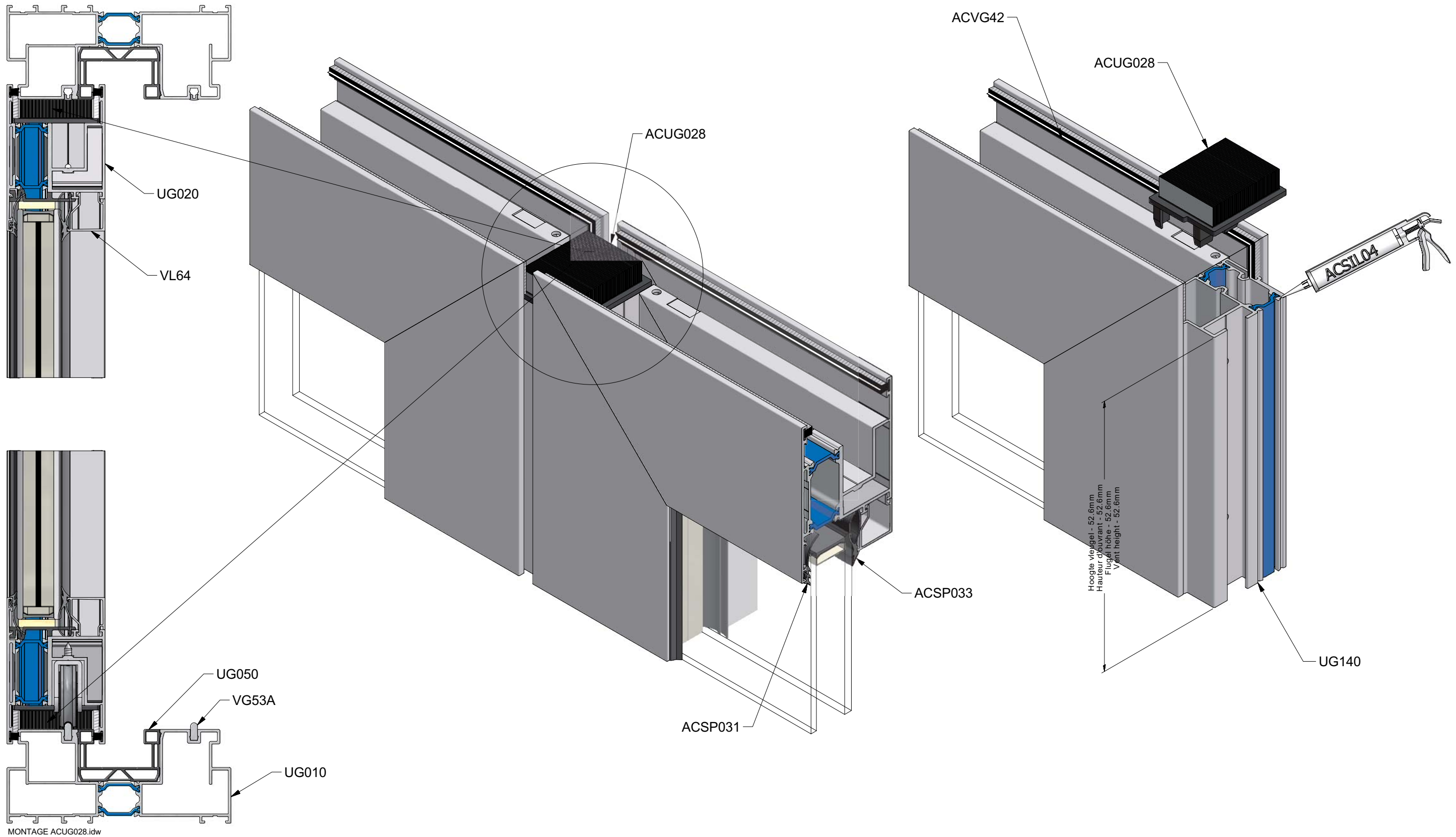

WERKTEKENINGEN - DESSINS DE CONSTRUCTION - KONSTRUKTIONZEICHNUNGEN - CONSTRUCTION DRAWINGS

MONTAGE ACUG128
MONTAGE ACUG128
MONTAGE ACUG128
MONTAGE ACUG128

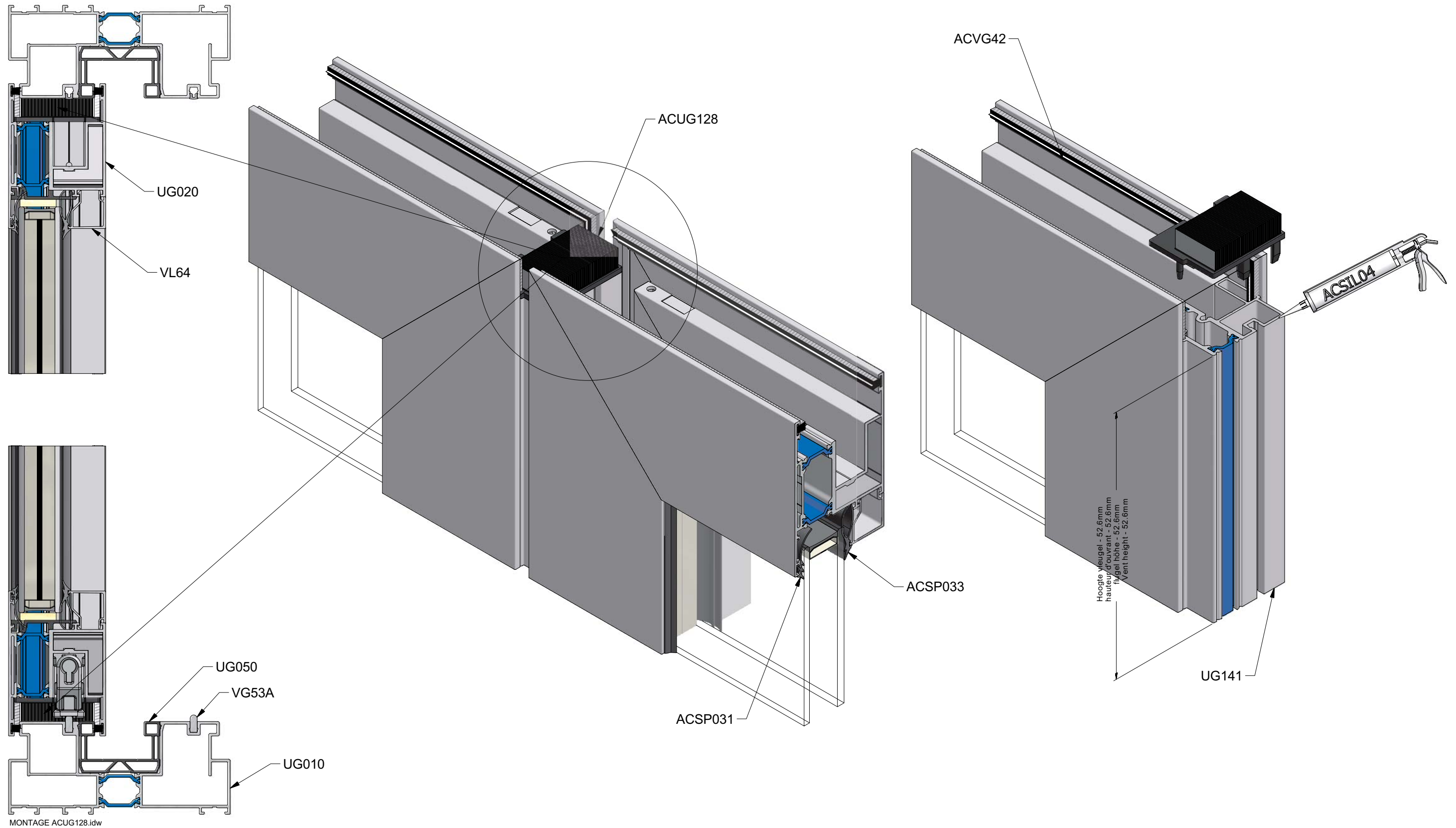

MONTAGE ACUG120
MONTAGE ACUG120
MONTAGE ACUG120
MONTAGE ACUG120

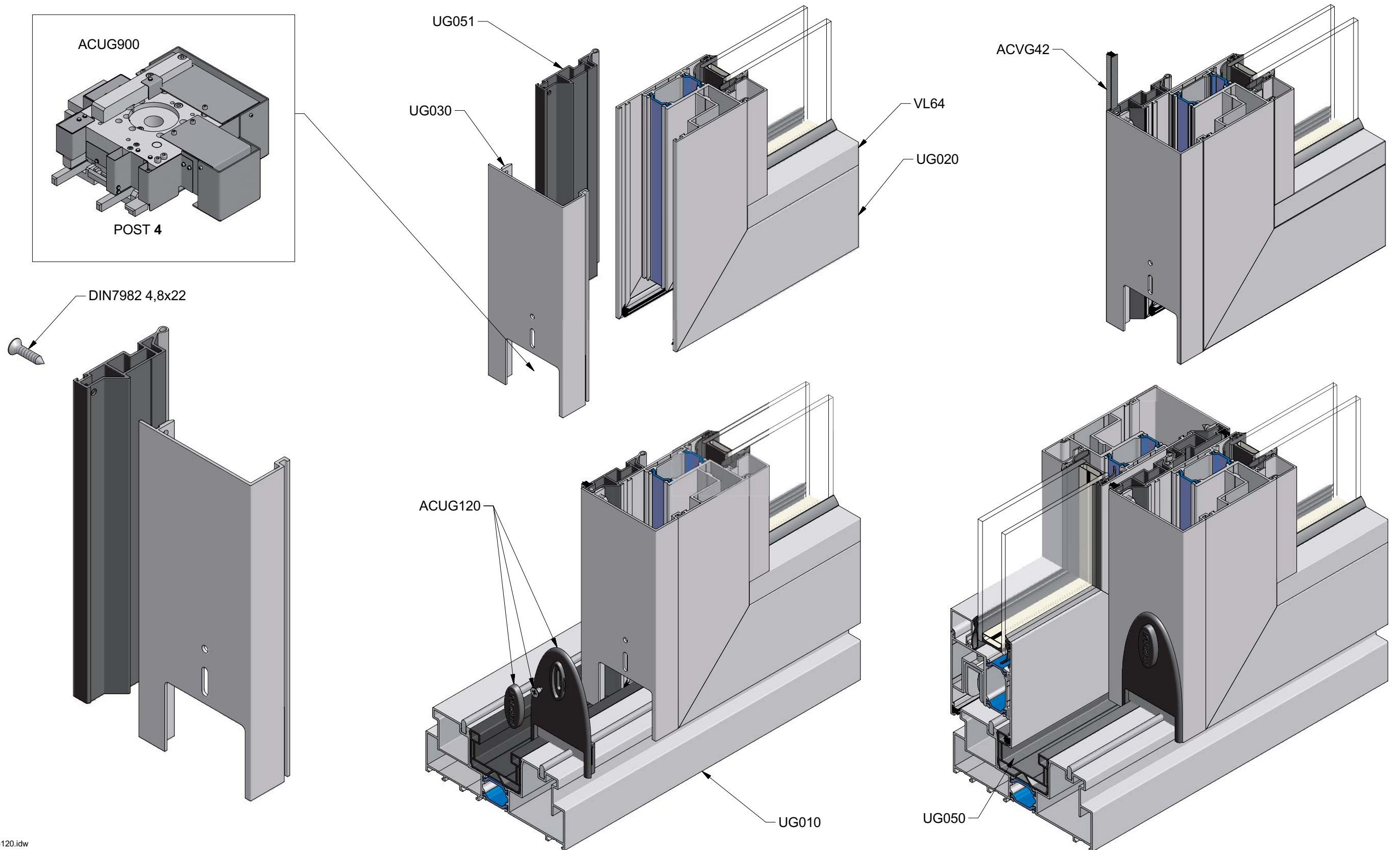

MONTAGE ACUG120.idw

WERKTEKENINGEN - DESSINS DE CONSTRUCTION - KONSTRUKTIONZEICHNUNGEN - CONSTRUCTION DRAWINGS

MONTAGE ACUG030 - ACUG130
MONTAGE ACUG030 - ACUG130
MONTAGE ACUG030 - ACUG130
MONTAGE ACUG030 - ACUG130

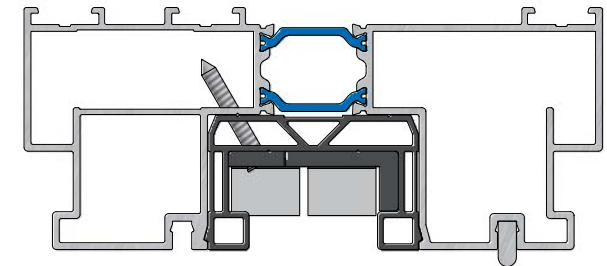
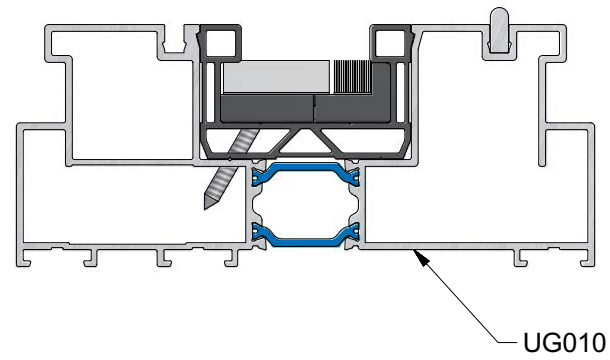
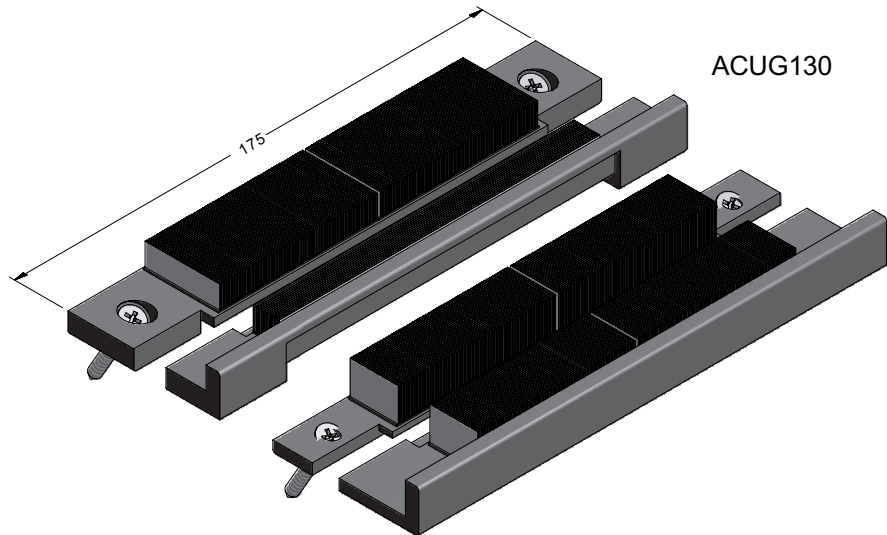
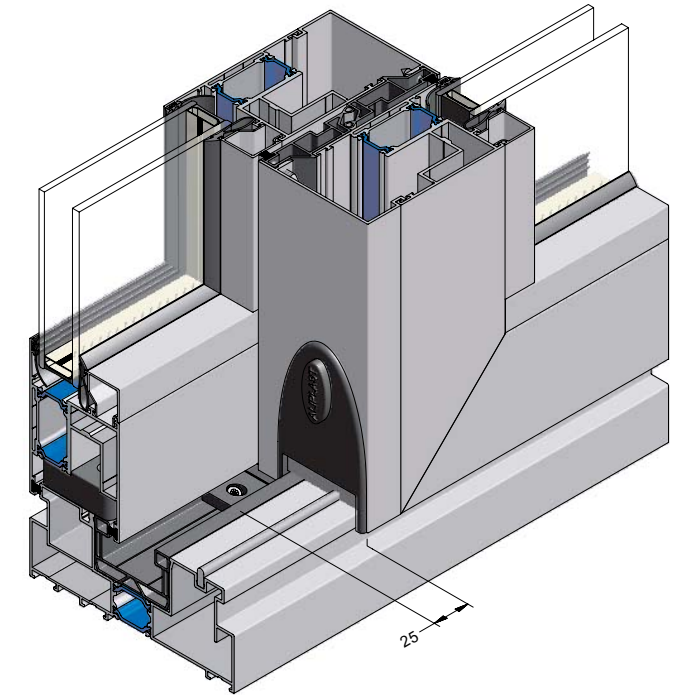
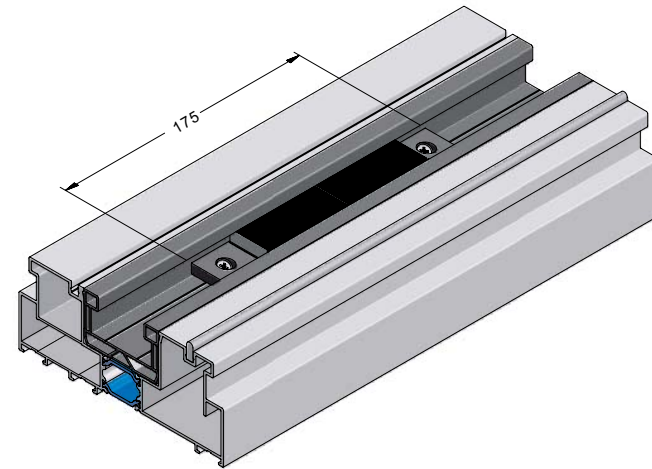
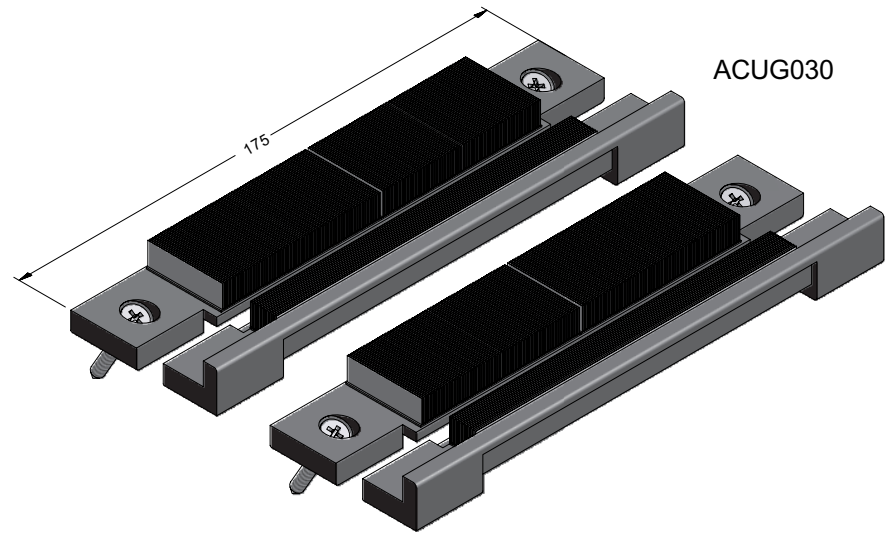

MONTAGE ACUG630 - ACUG730
 MONTAGE ACUG630 - ACUG730
 MONTAGE ACUG630 - ACUG730
 MONTAGE ACUG630 - ACUG730

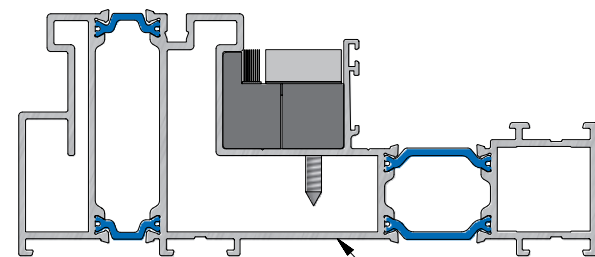
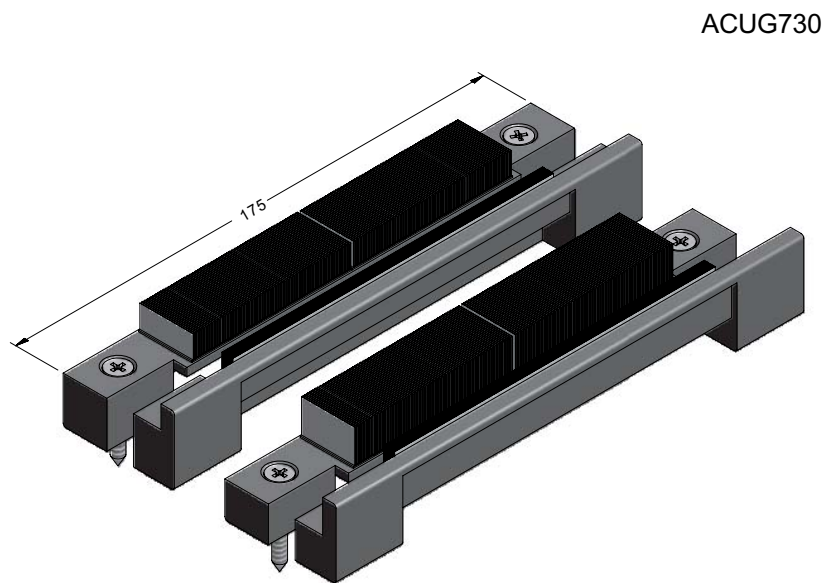
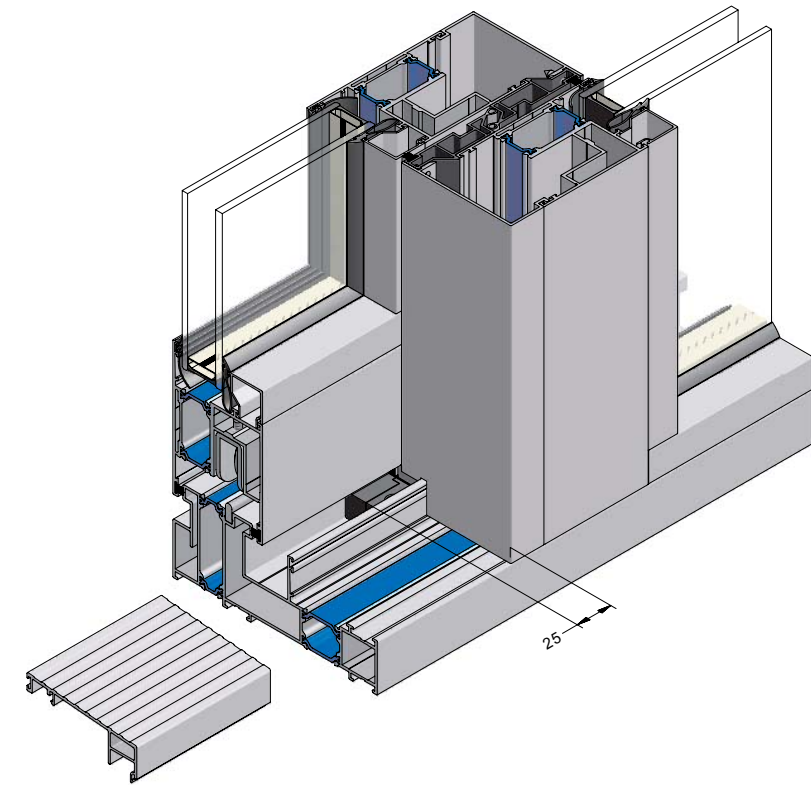
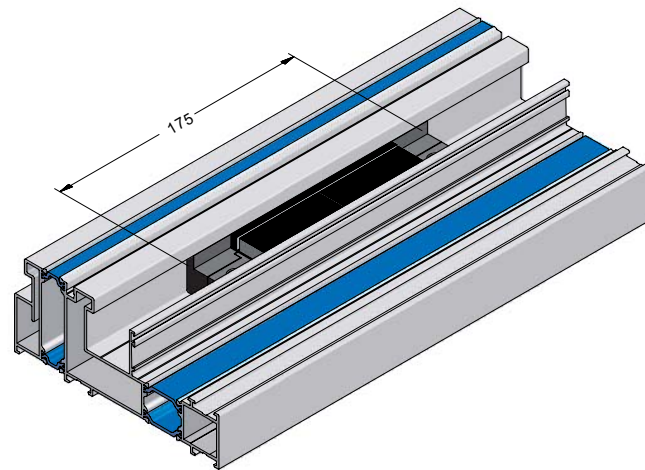
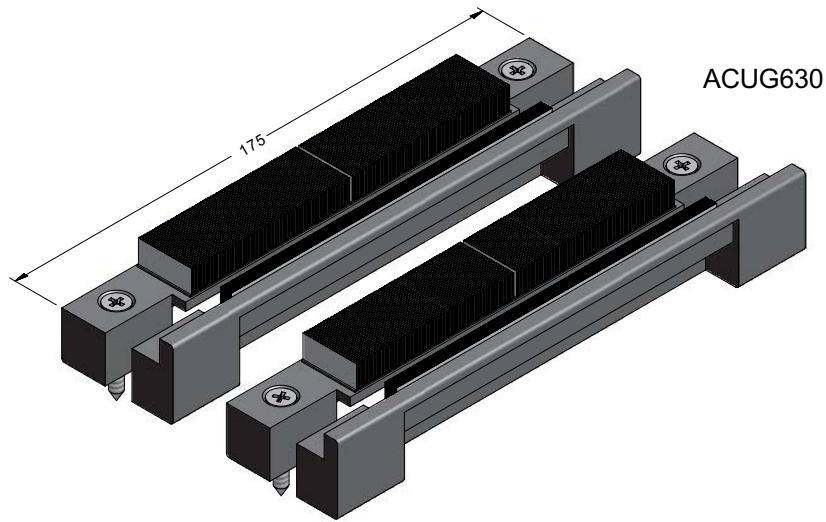

UG610

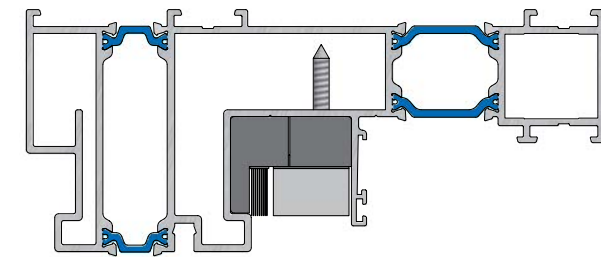

CENTRALE DICHTINGEN 2.idw

BEWERKING UG014-UG015 VOOR ACUG030
USINAGE UG014-UG015 POUR ACUG030
FABRIKATION UG014-UG015 FUR ACUG030
OPERATION UG014-UG015 FOR ACUG030

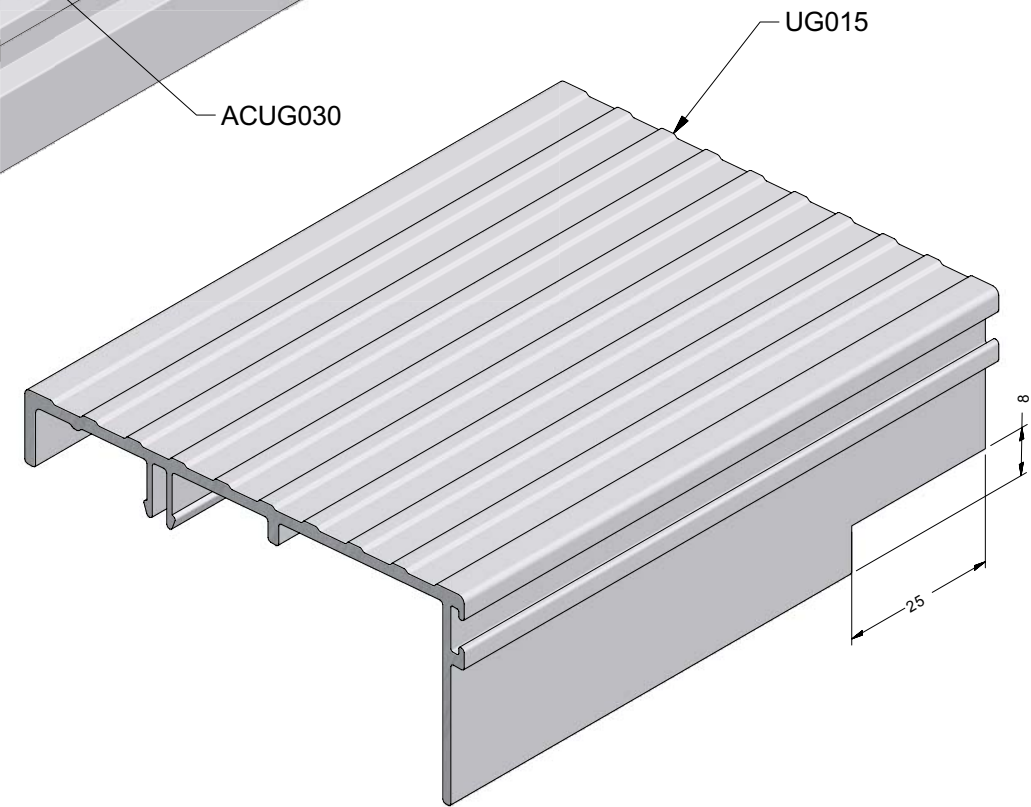
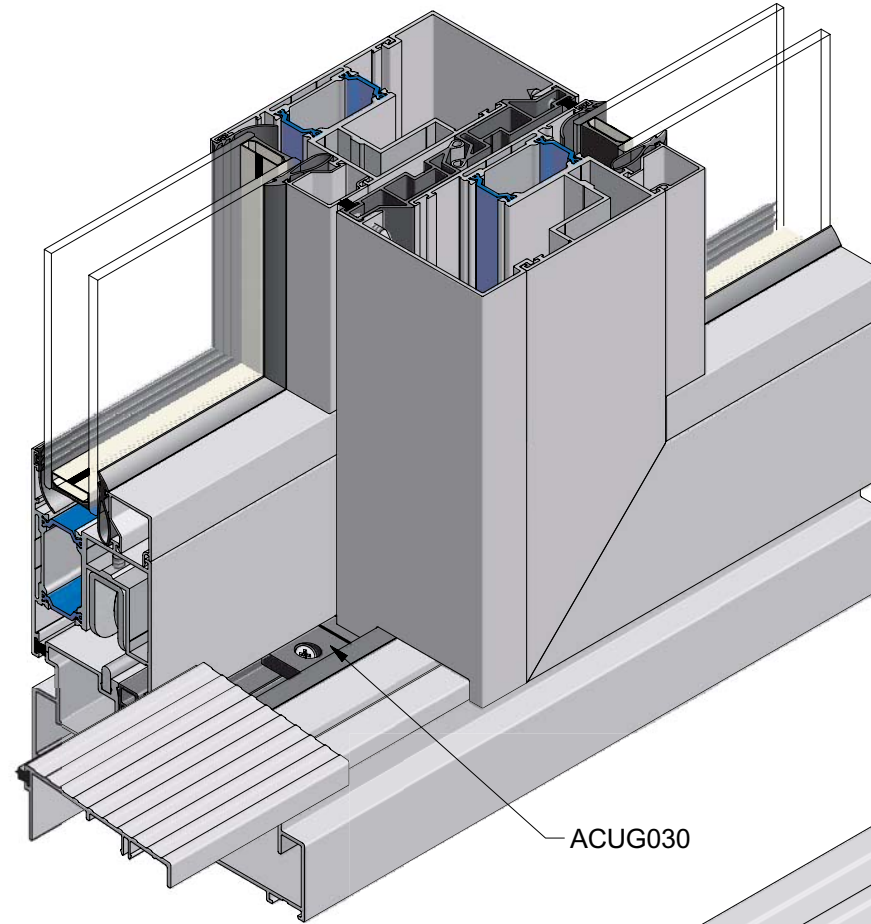
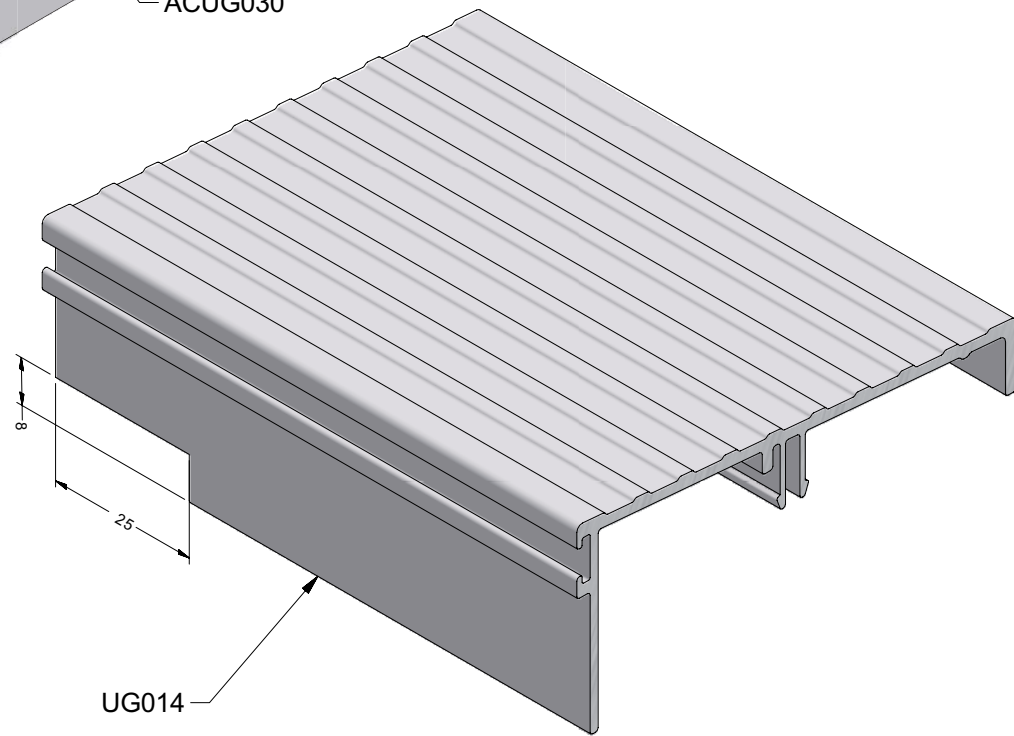
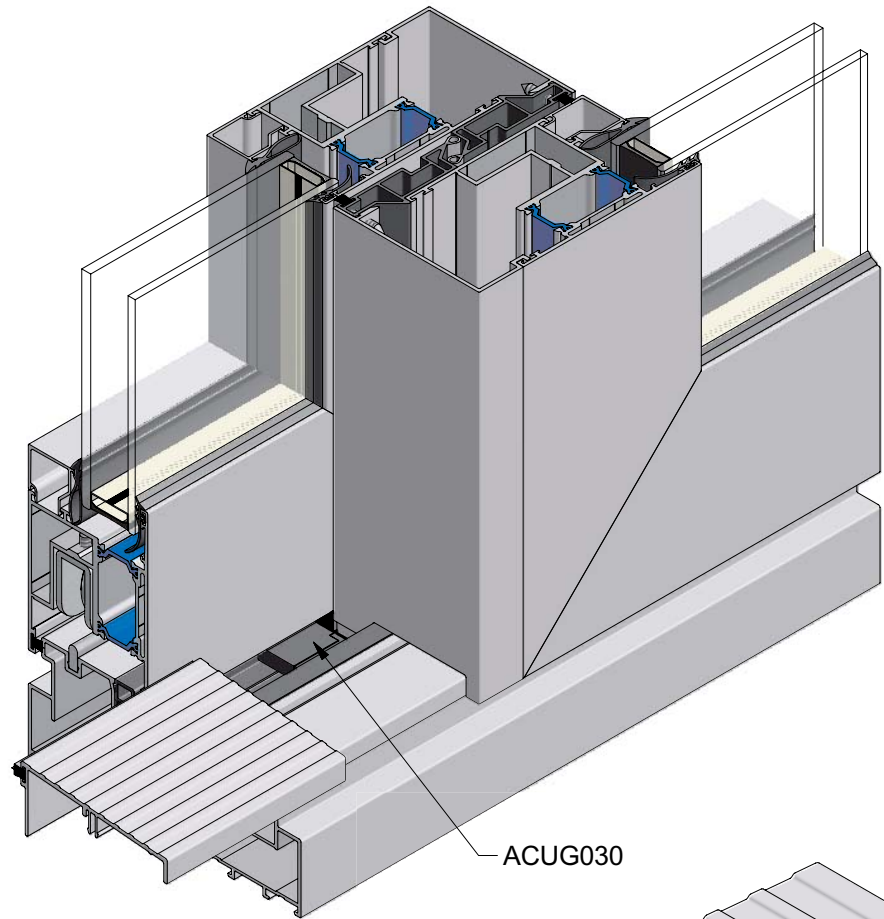

BEWERKING UG014-015 THV ACUG030.idw

MONTAGE ACUG031
MONTAGE ACUG031
MONTAGE ACUG031
MONTAGE ACUG031

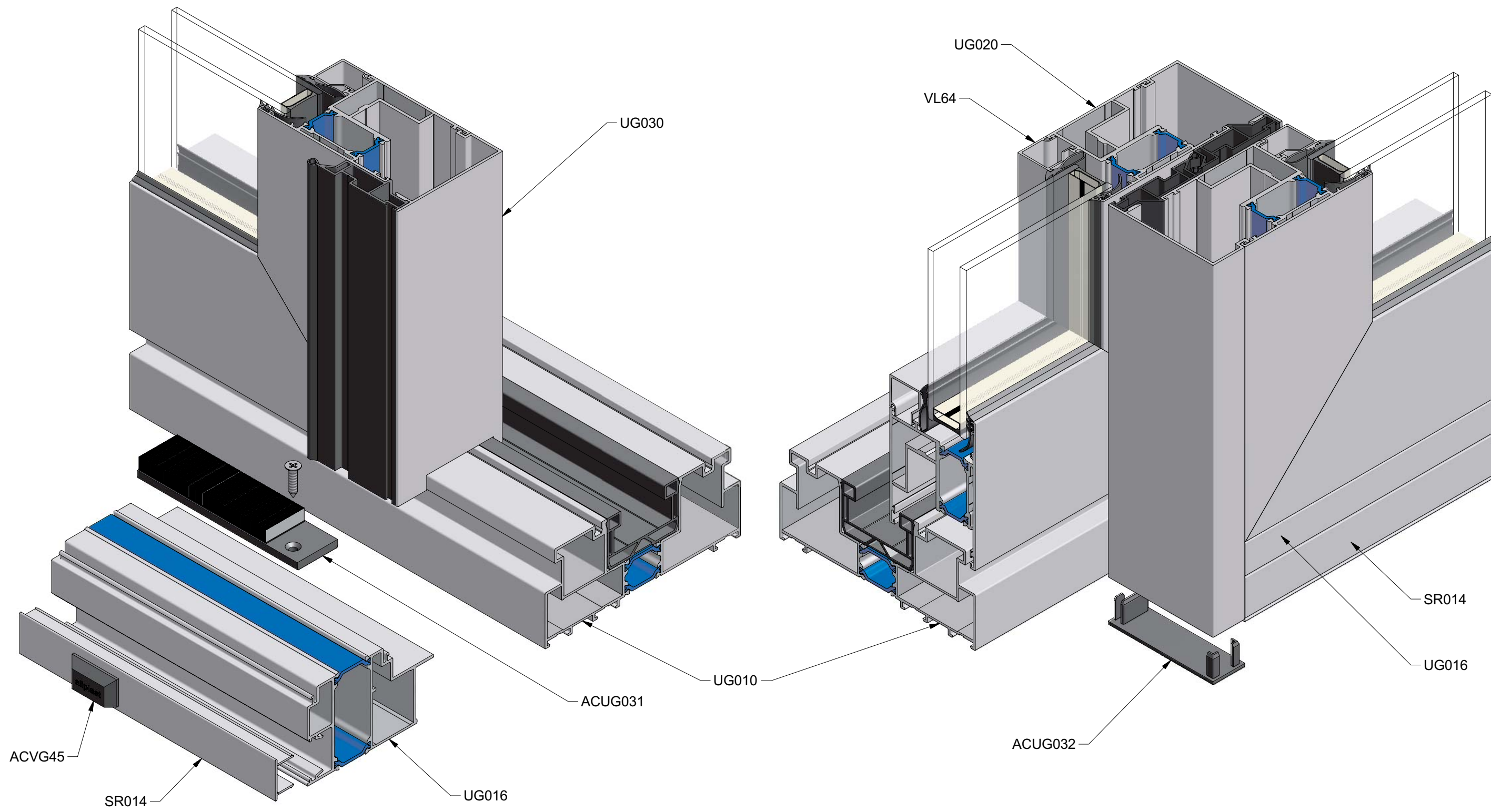

MONTAGE ACUG031.idw

WERKTEKENINGEN - DESSINS DE CONSTRUCTION - KONSTRUKTIONZEICHNUNGEN - CONSTRUCTION DRAWINGS

UITFREZING UG030 BIJ VASTE VLEUGEL
ENTAILLE UG030 POUR VANTAIL FIXE
EINBAU UG030 FÜR FEST FLÜGEL
CUT UG030 FOR FIXED VENT

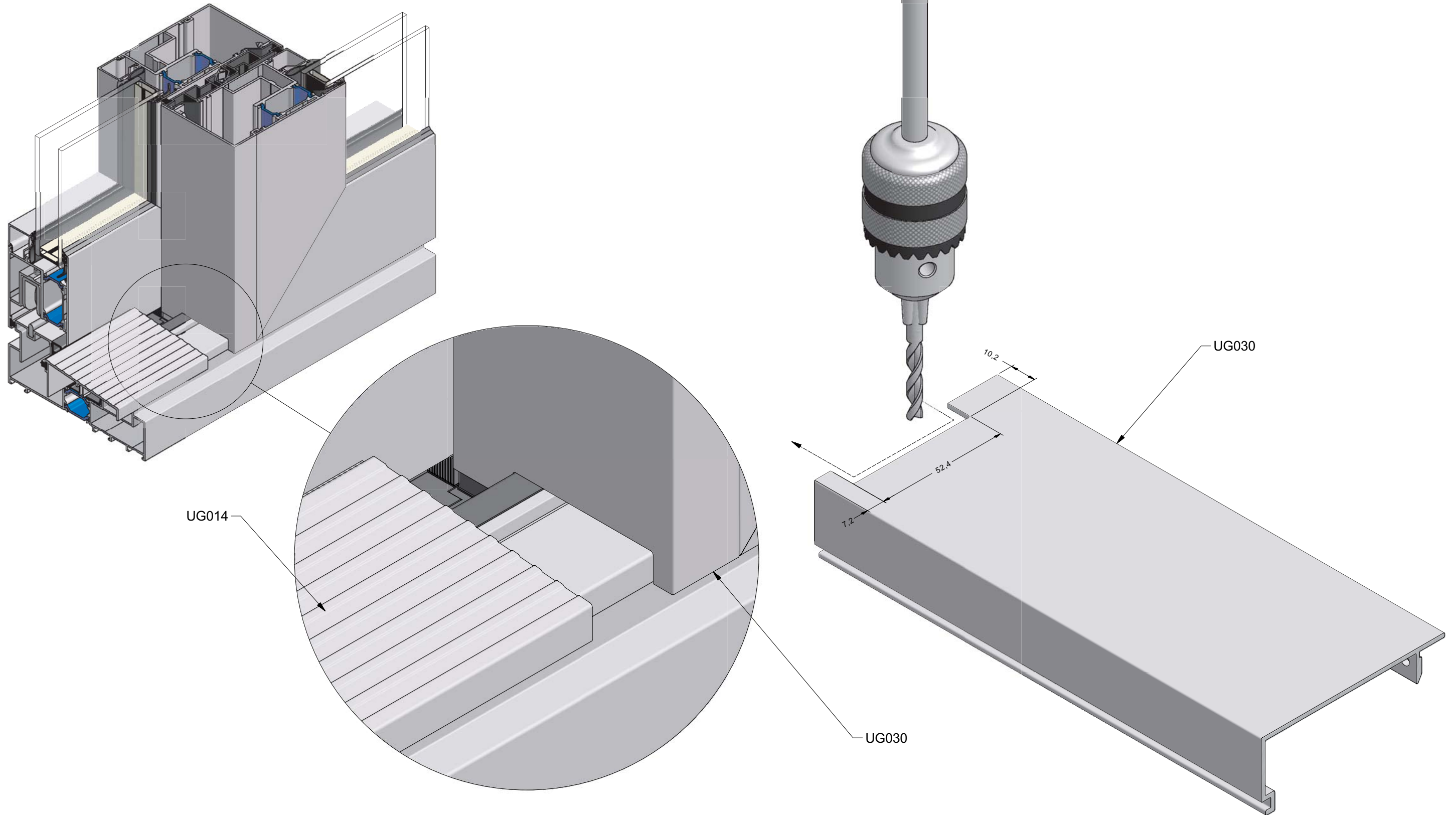

UITFREZING UG030 BIJ VASTE VLEUGEL.idw

MONTAGE ACUG044
MONTAGE ACUG044
MONTAGE ACUG044
MONTAGE ACUG044

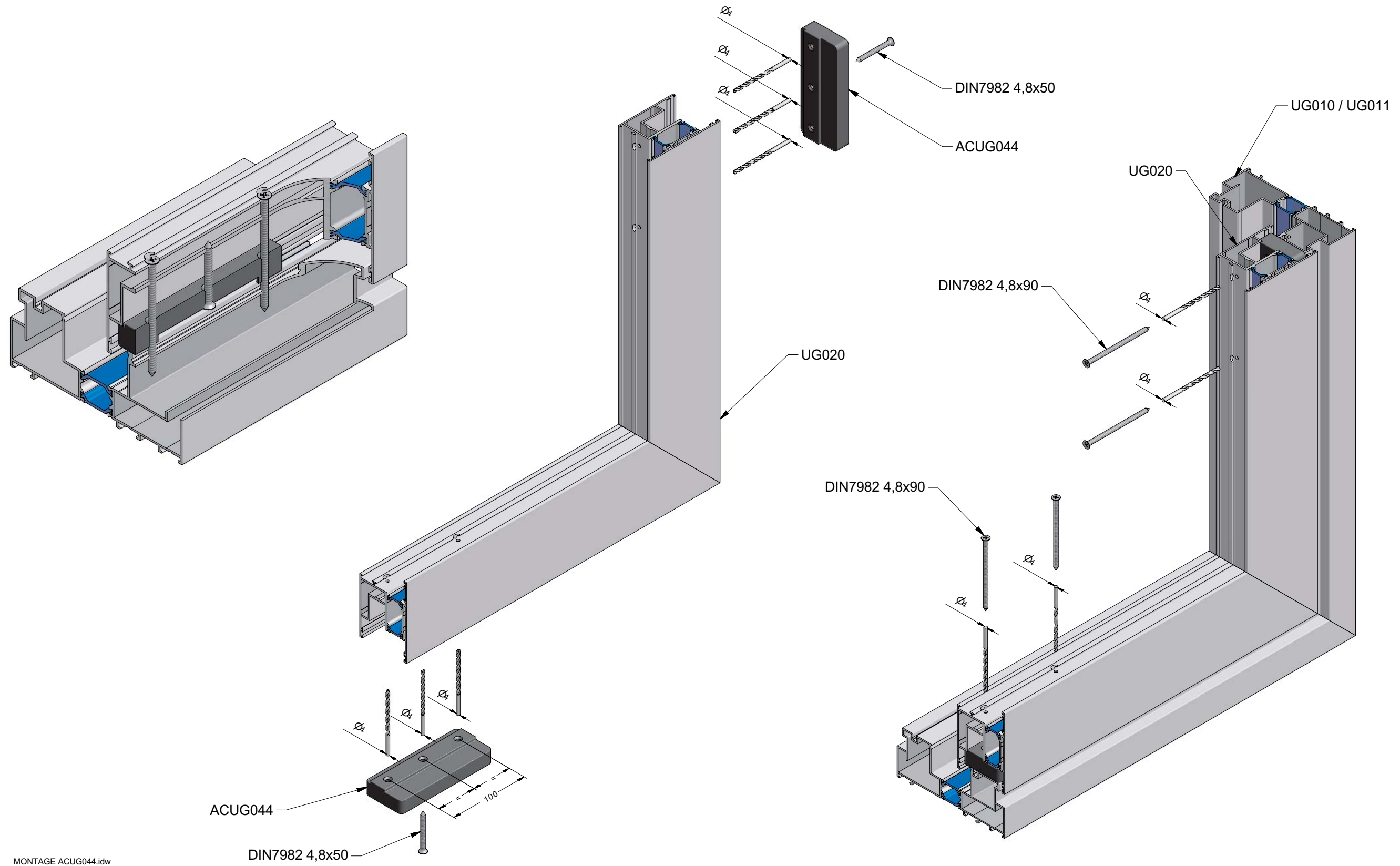

MONTAGE ACUG044.idw

MONTAGE ACUG048
 MONTAGE ACUG048
 MONTAGE ACUG048
 MONTAGE ACUG048

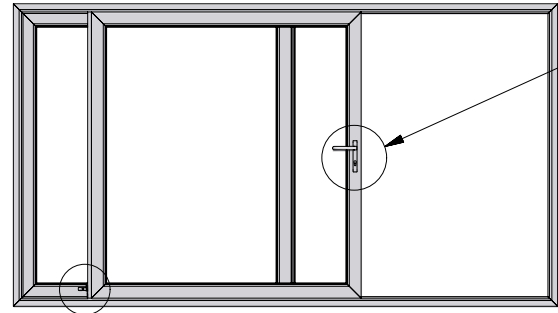

PLAATS VAN DE BUFFER TE BEPALEN MET OPEN VLEUGEL
 PLACE DE LA BUTEE A DETERMINER AVEC OUVRANT OUVERT
 STELLE DES STOPPERS ZU BESTIMMEN MIT GEÖFFNETEM FLÜGEL
 PLACE OF BUFFER TO DETERMINE WITH OPEN VENT

VLEUGELGEWICHT POIDS DU VANTAIL FLÜGELGEWICHT WEIGHT OF THE VENT	MAX 300KG
---	-----------

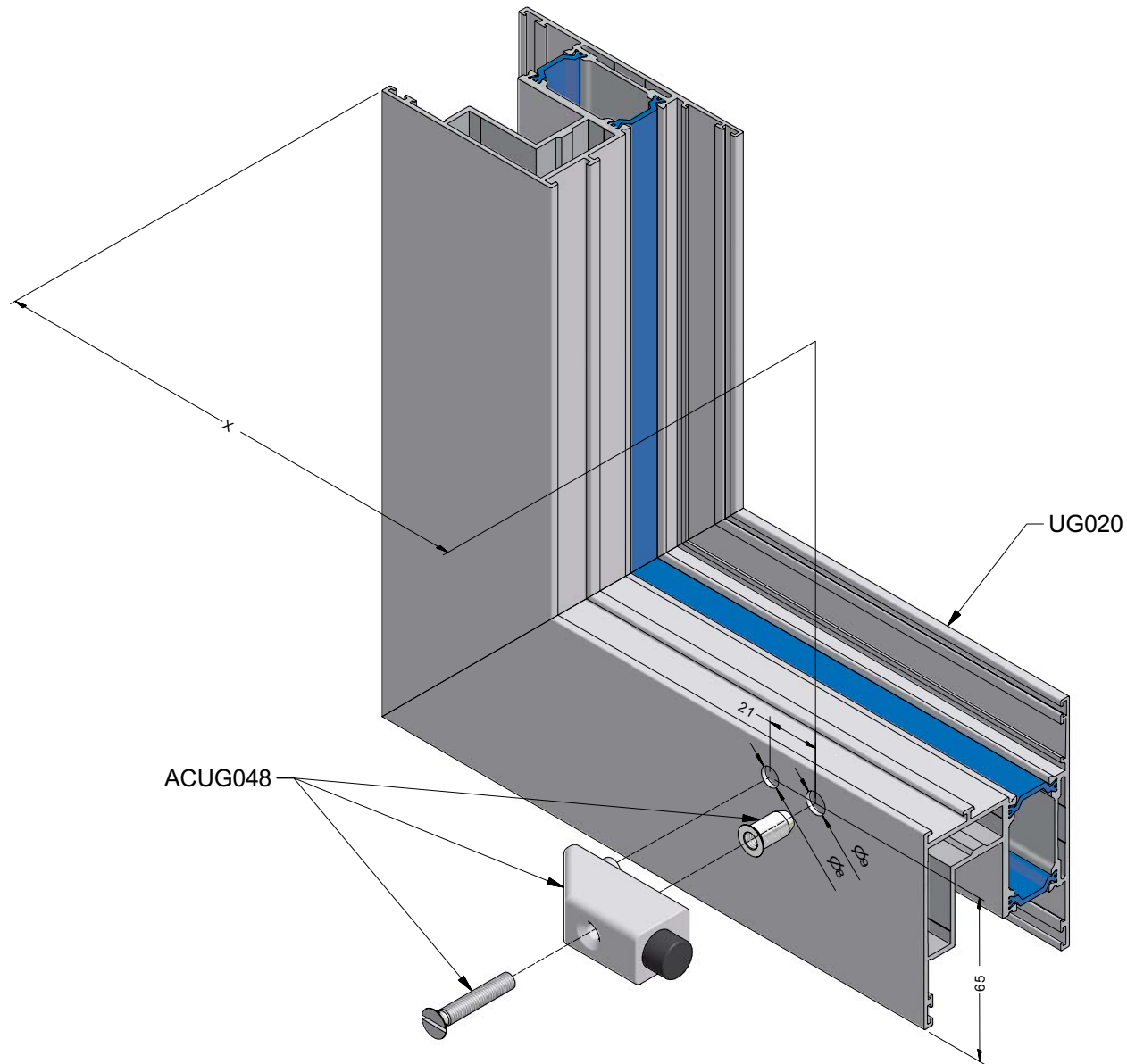

MONTAGE STOOTBUFFERS.idw

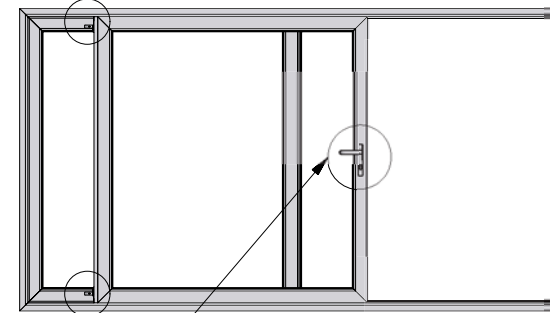

PLAATS VAN DE BUFFER TE BEPALEN MET OPEN VLEUGEL
 PLACE DE LA BUTEE A DETERMINER AVEC OUVRANT OUVERT
 STELLE DES STOPPERS ZU BESTIMMEN MIT GEÖFFNETEM FLÜGEL
 PLACE OF BUFFER TO DETERMINE WITH OPEN VENT

VLEUGELGEWICHT POIDS DU VANTAIL FLÜGELGEWICHT WEIGHT OF THE VENT	MAX 400KG
---	-----------

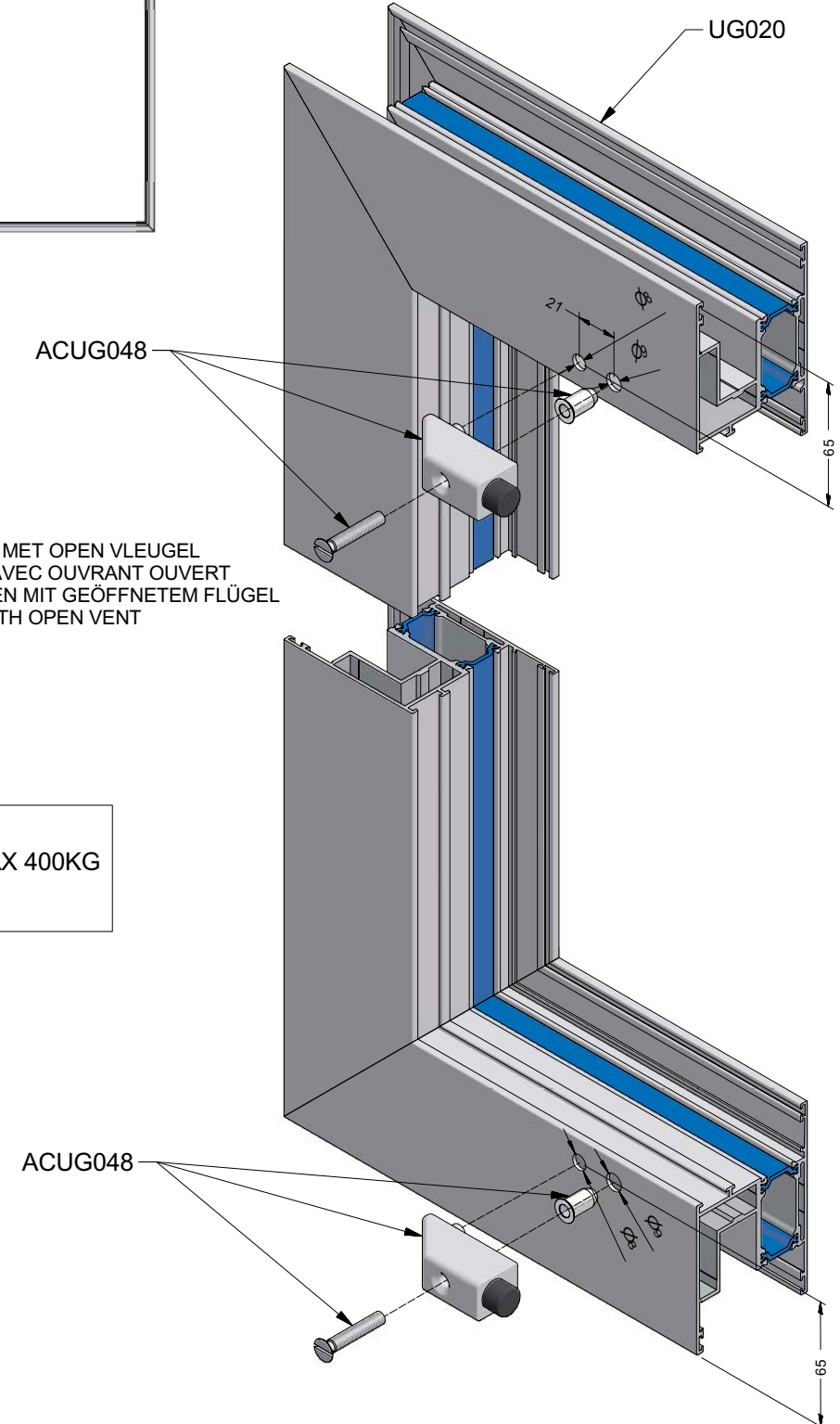

MONTAGE ACUG040
MONTAGE ACUG040
MONTAGE ACUG040
MONTAGE ACUG040

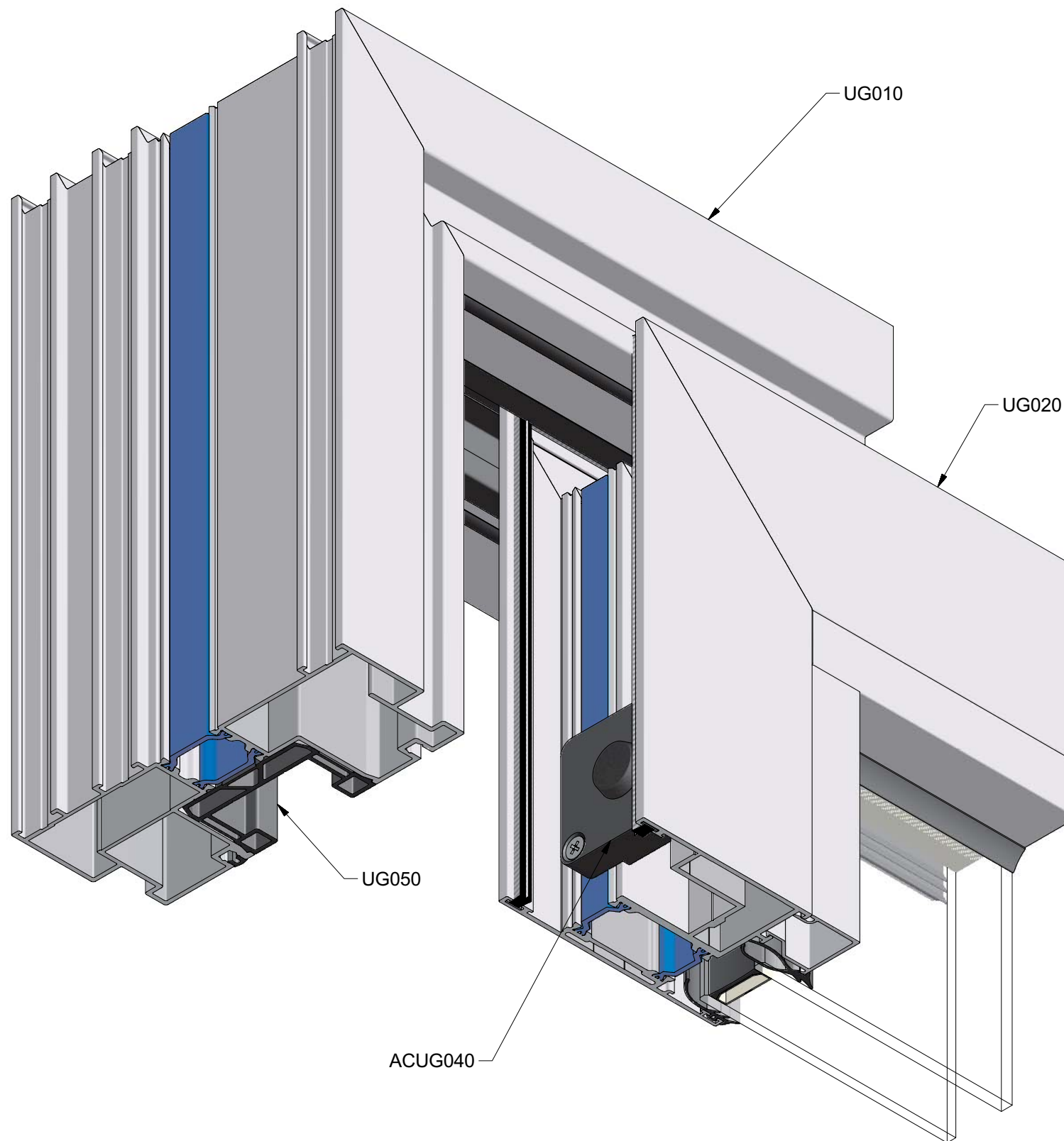
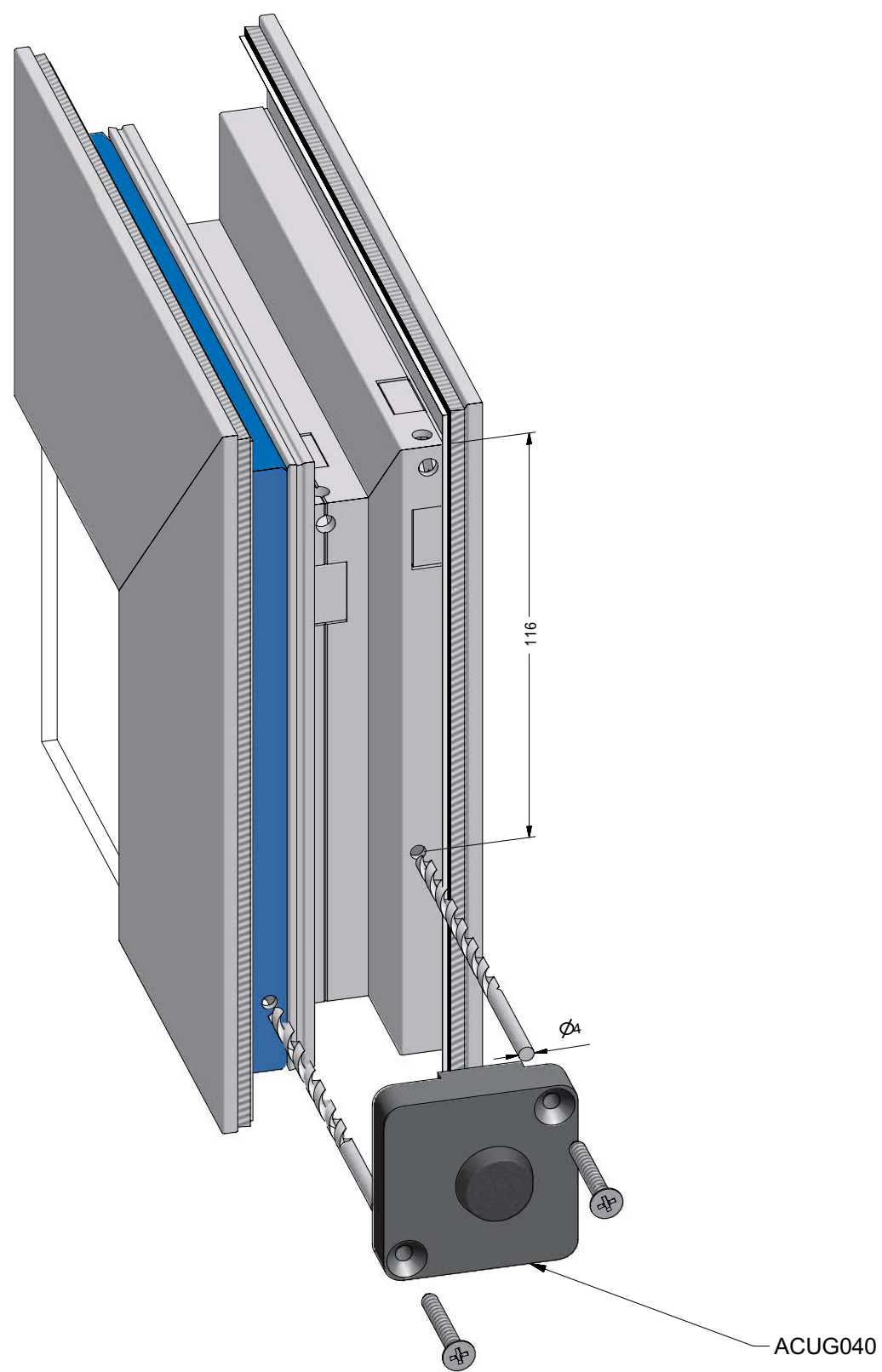

MONTAGE ACUG040.idw

MONTAGE ACUG029
MONTAGE ACUG029
MONTAGE ACUG029
MONTAGE ACUG029

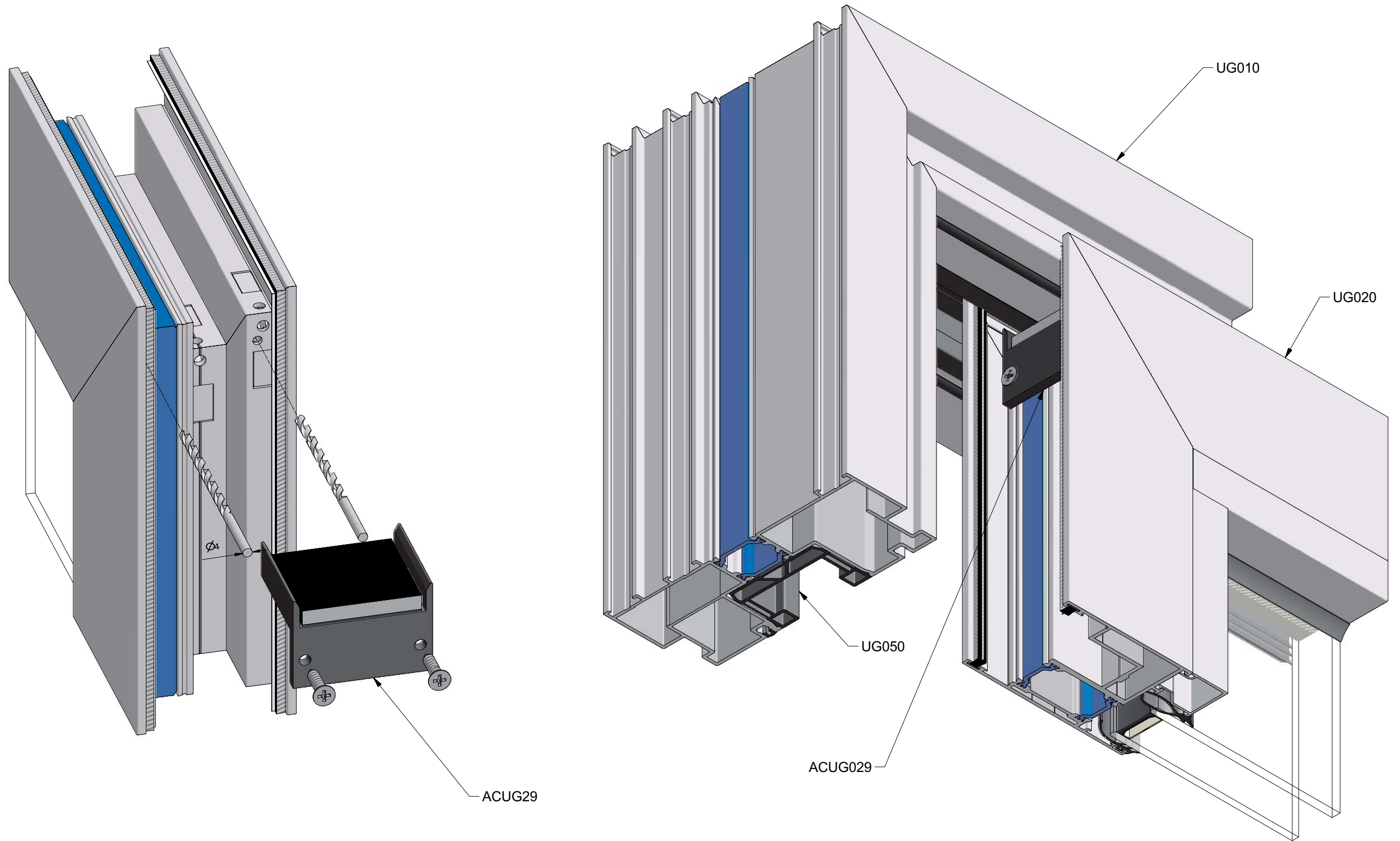

MONTAGE ACUG029.idw

MONTAGE ACUG110
MONTAGE ACUG110
MONTAGE ACUG110
MONTAGE ACUG110

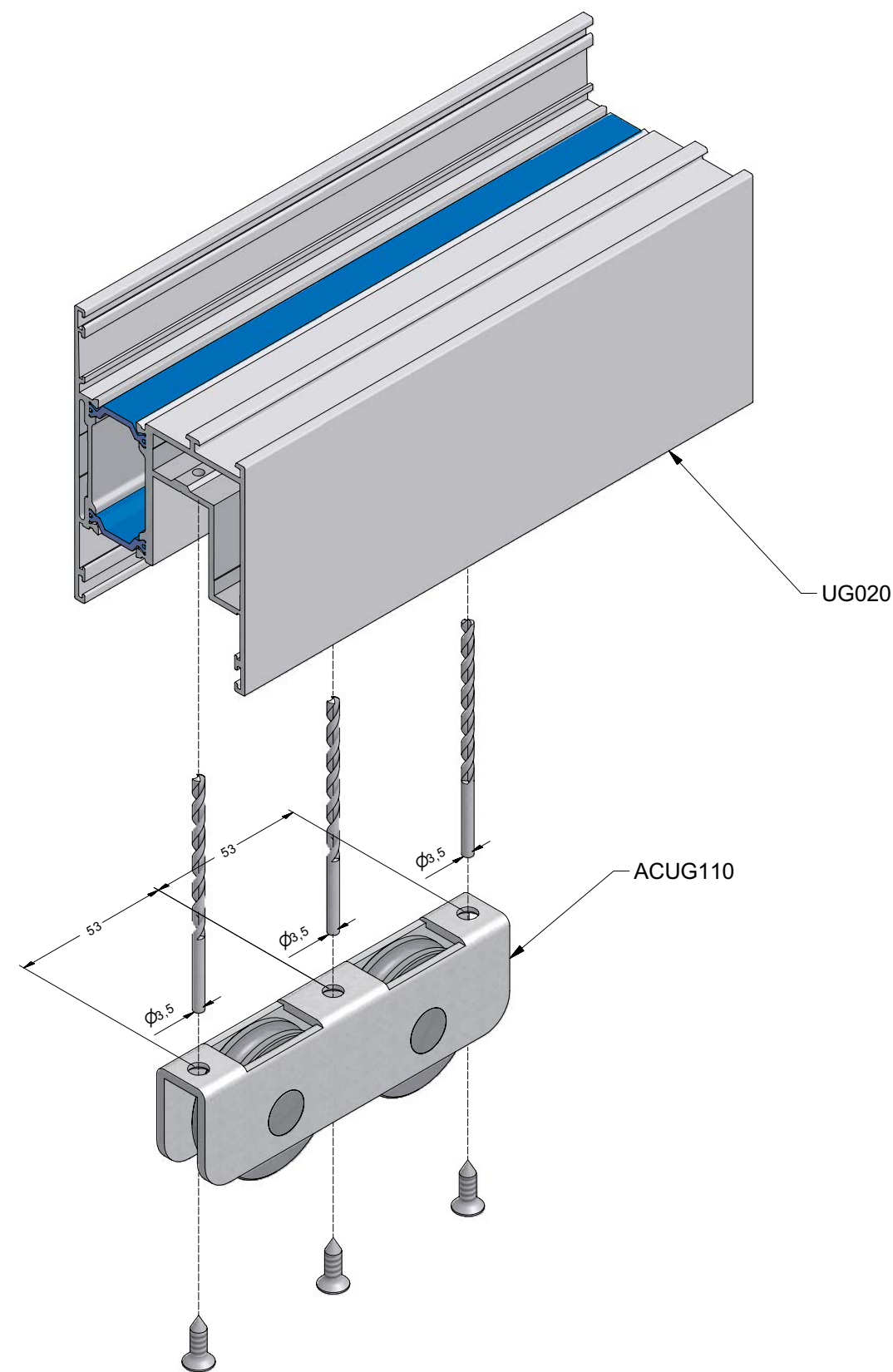
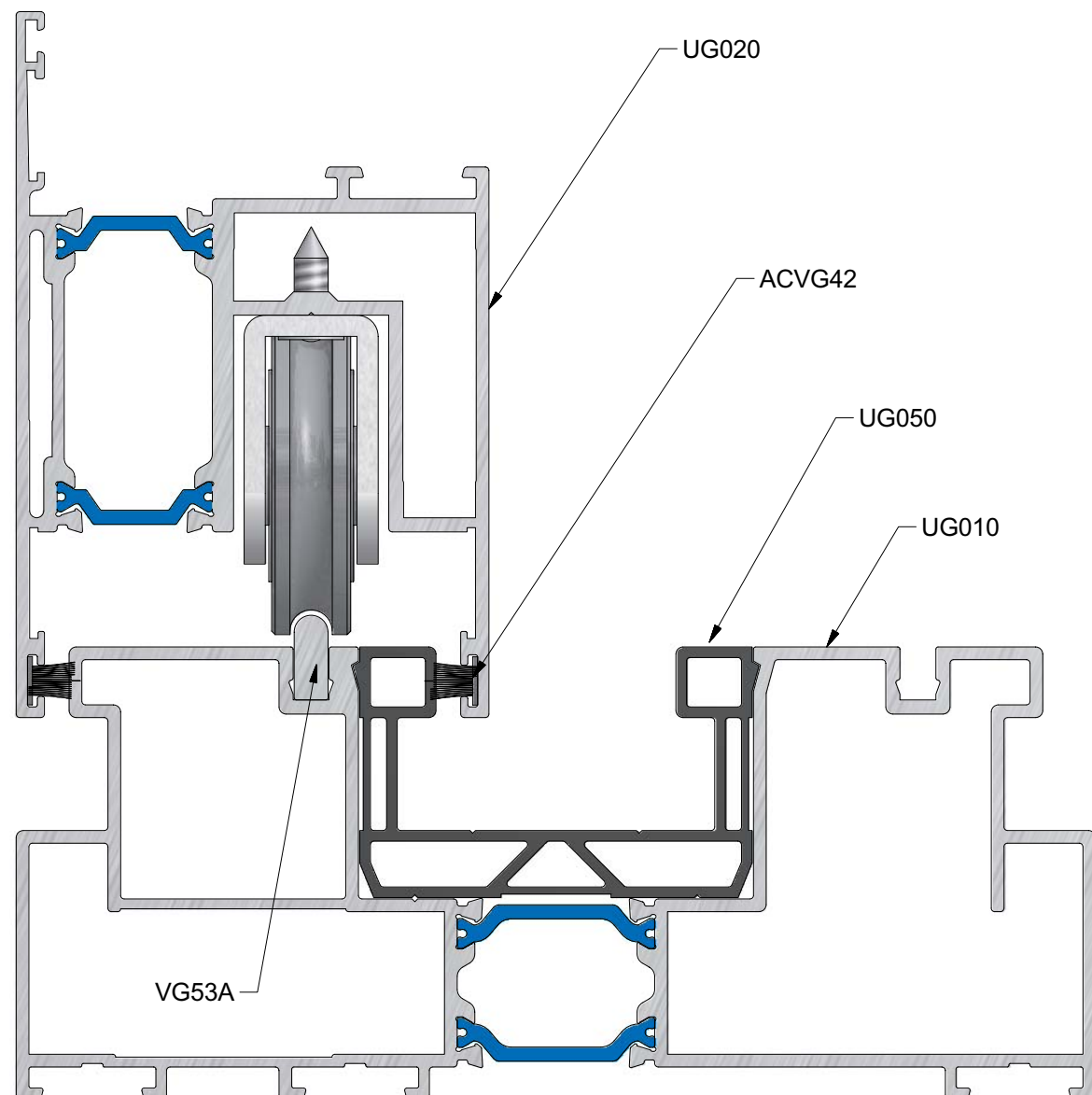

MONTAGE ACUG110.idw

MONTAGE UG140
MONTAGE UG140
MONTAGE UG140
MONTAGE UG140

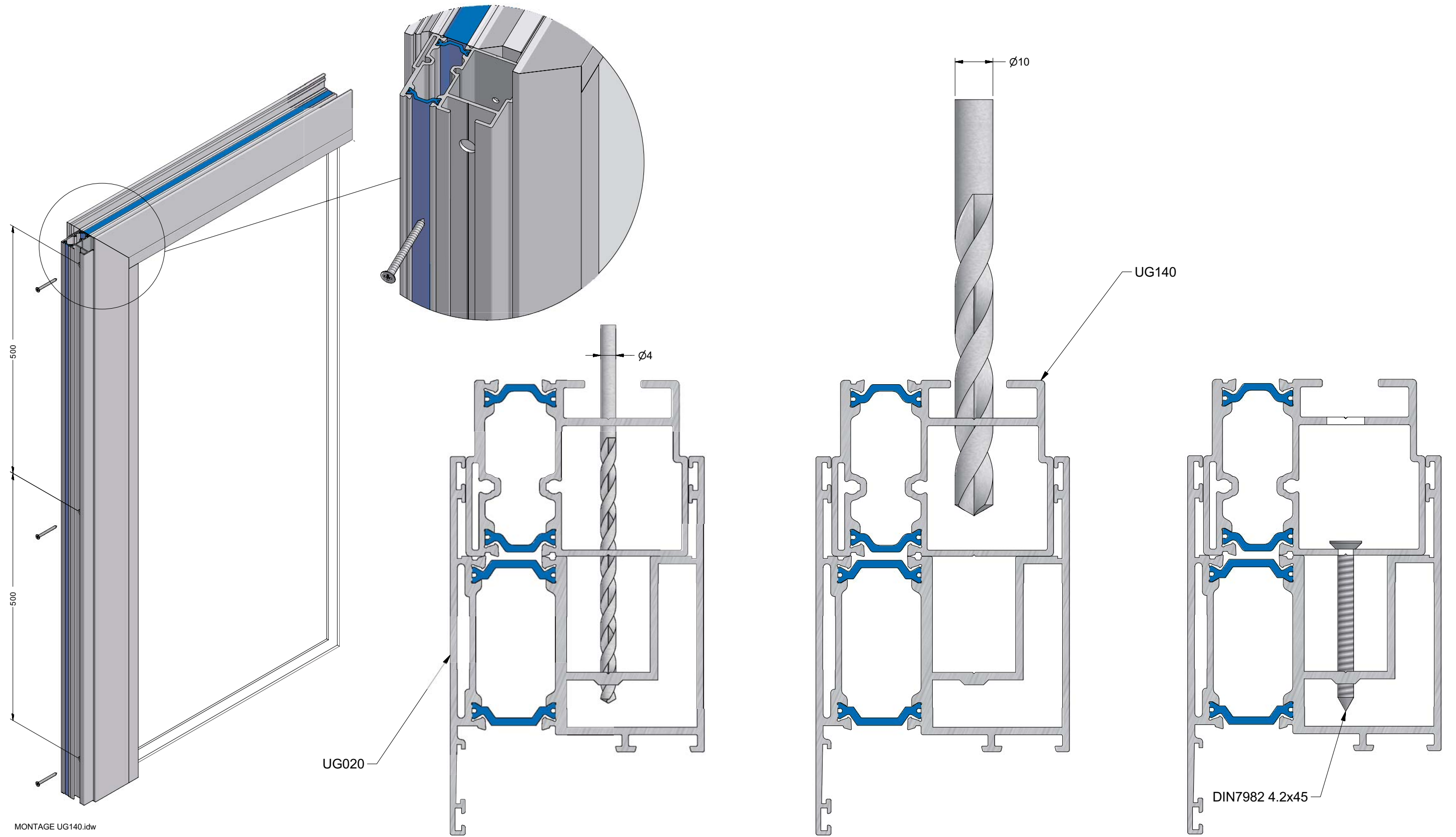

ONTWATERING BUITENKADER MET ACUG900
 DRAINAGE PROFILS D'ENCADREMENT AVEC ACUG900
 ENTWASSERUNG KADERPROFILE MIT ACUG900
 DRAINING OUTER FRAME WITH ACUG900

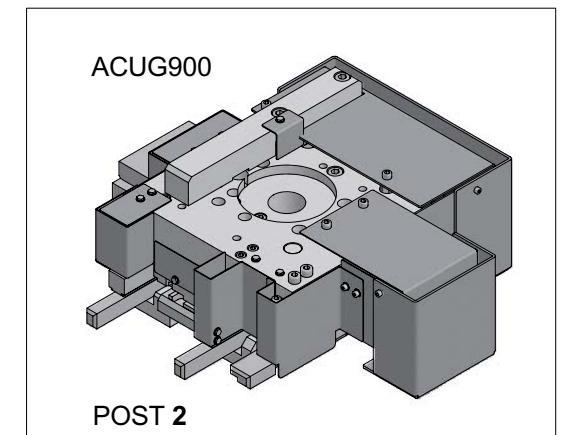
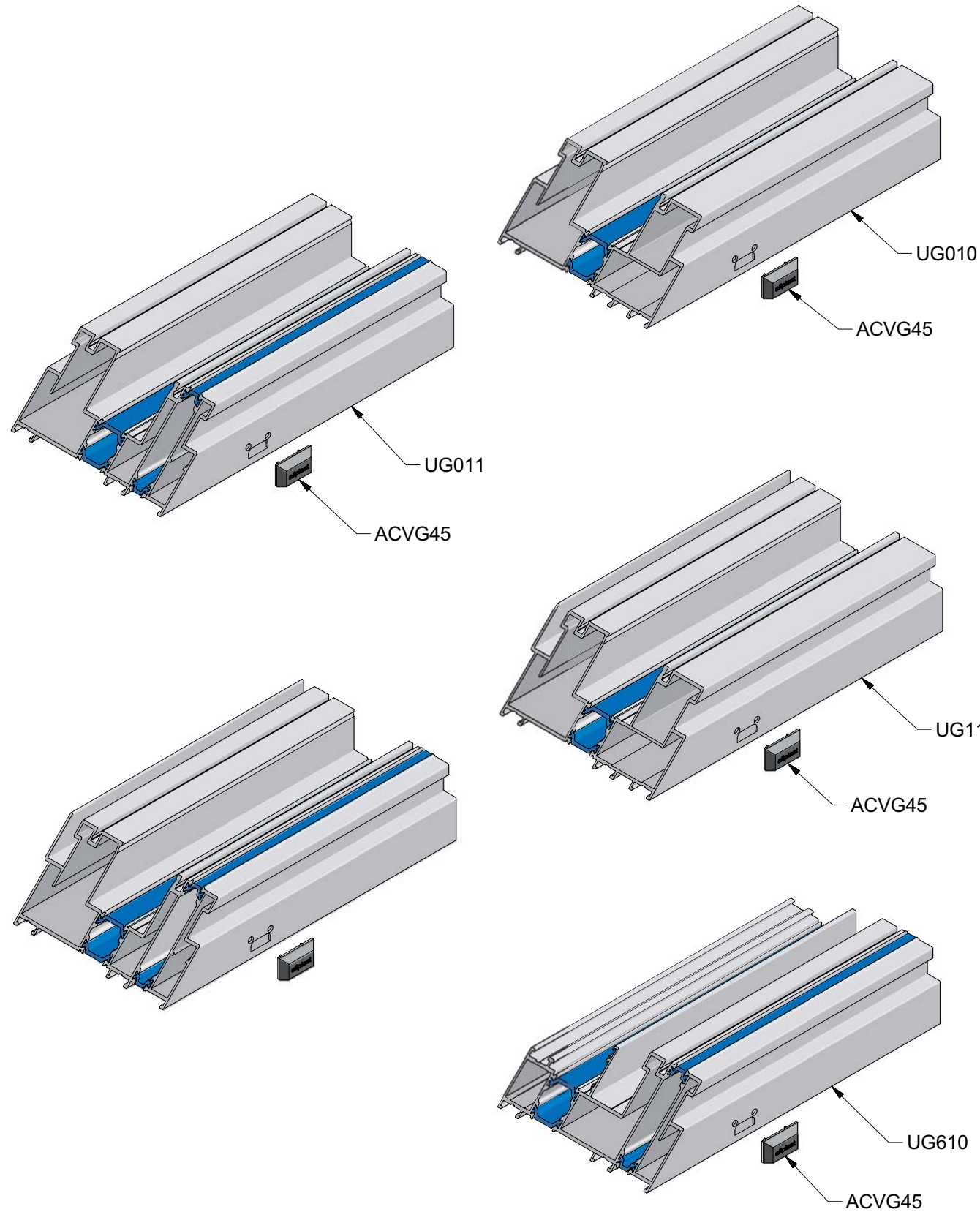
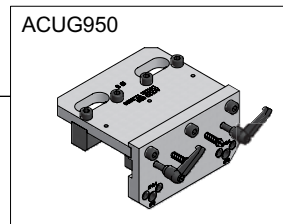
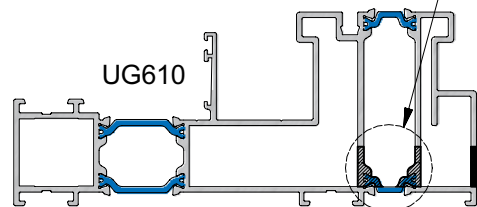
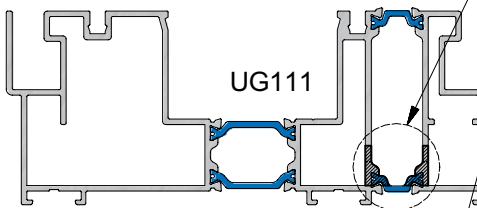
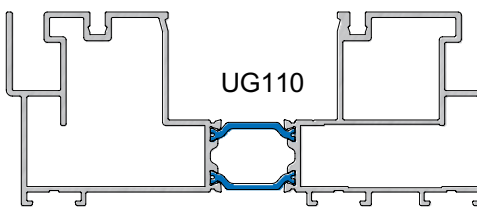
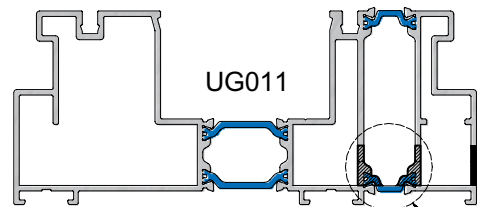
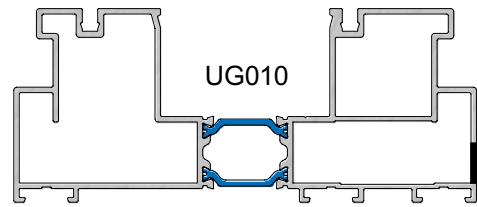

ONTWATERING BUITENKADER MET KAPMATRIJS.idw

ONTWATERING BUITENKADERS MET ACUG950
 DRAINAGE PROFILS D'ENCADREMENT AVEC ACUG950
 ENTWASSERUNG KADERPROFILIEN MIT ACUG950
 DRAINING OUTER FRAMES WITH ACUG950

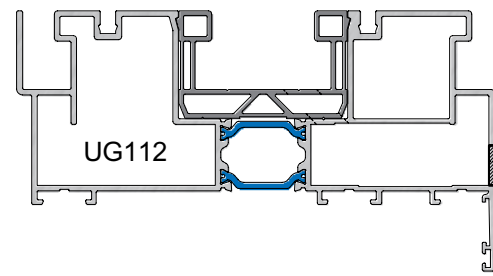
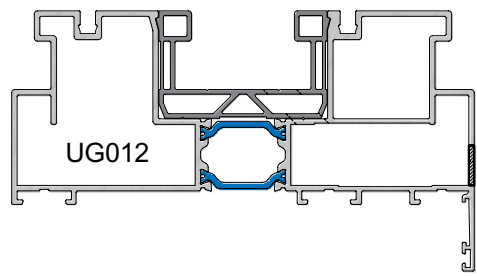
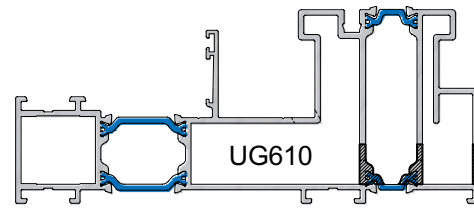
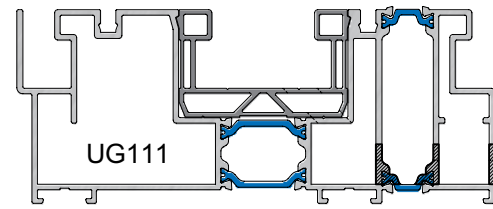
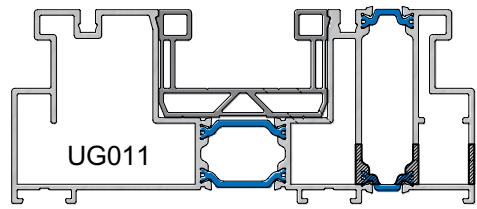
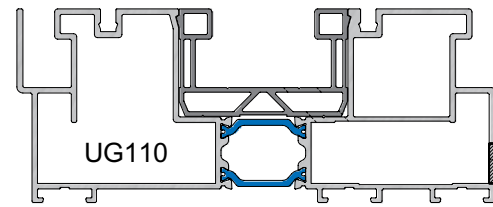
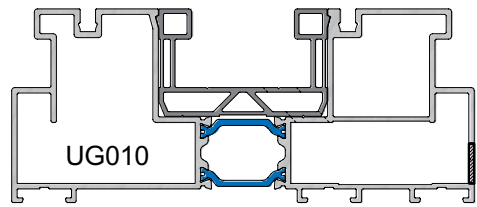

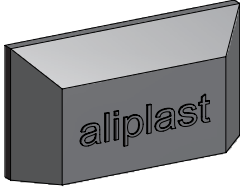
 = $\frac{B - 200\text{mm}}{800} + 1$

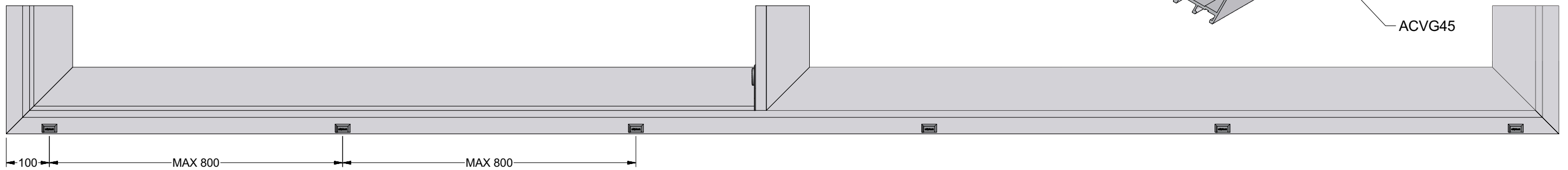
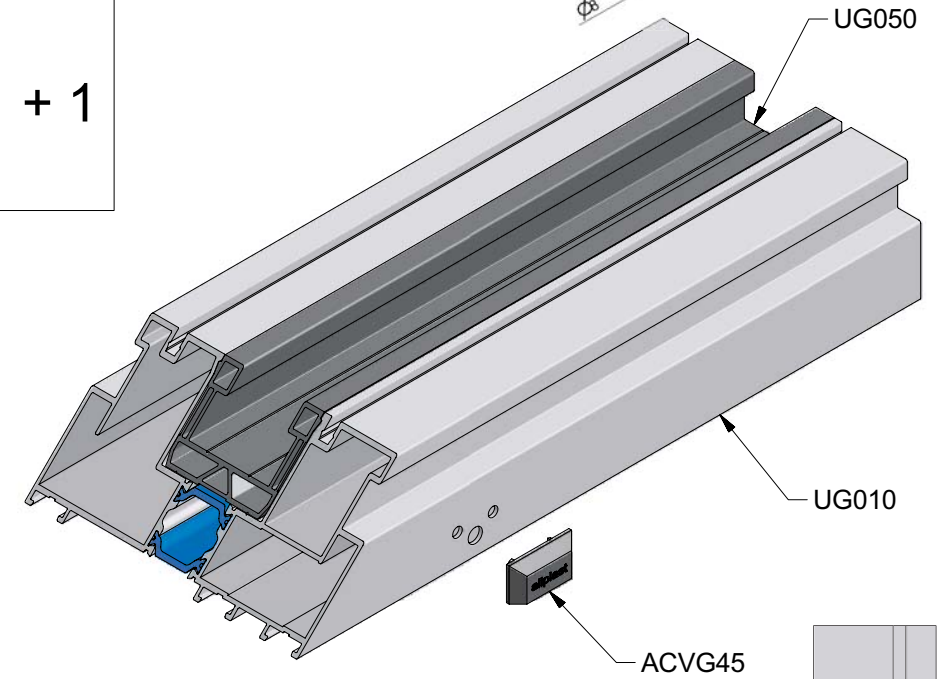
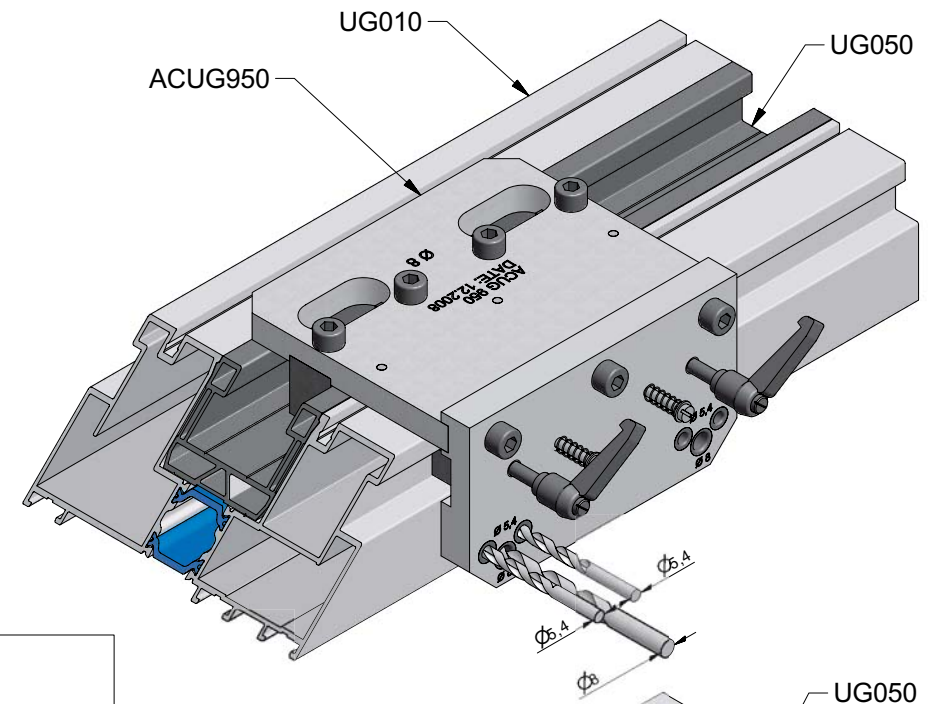
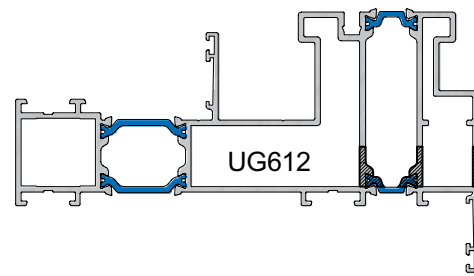
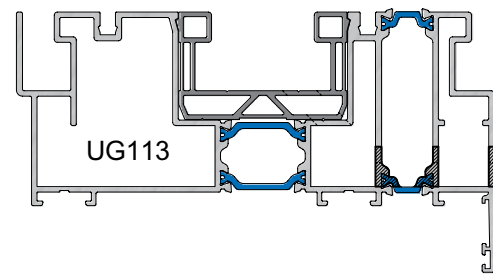
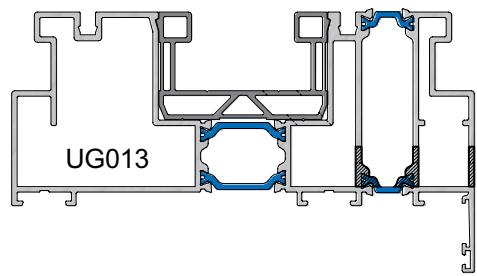

ONTWATERING BUITENKADER MET BOORMAL.idw

VERDOKEN AFWATERING UG010 - UG110
 DRAINAGE INVISIBLE UG010 - UG110
 UNSICHTBAR ENTWASSERUNG UG010 - UG110
 DRAINING INVISIBLE UG010 - UG110

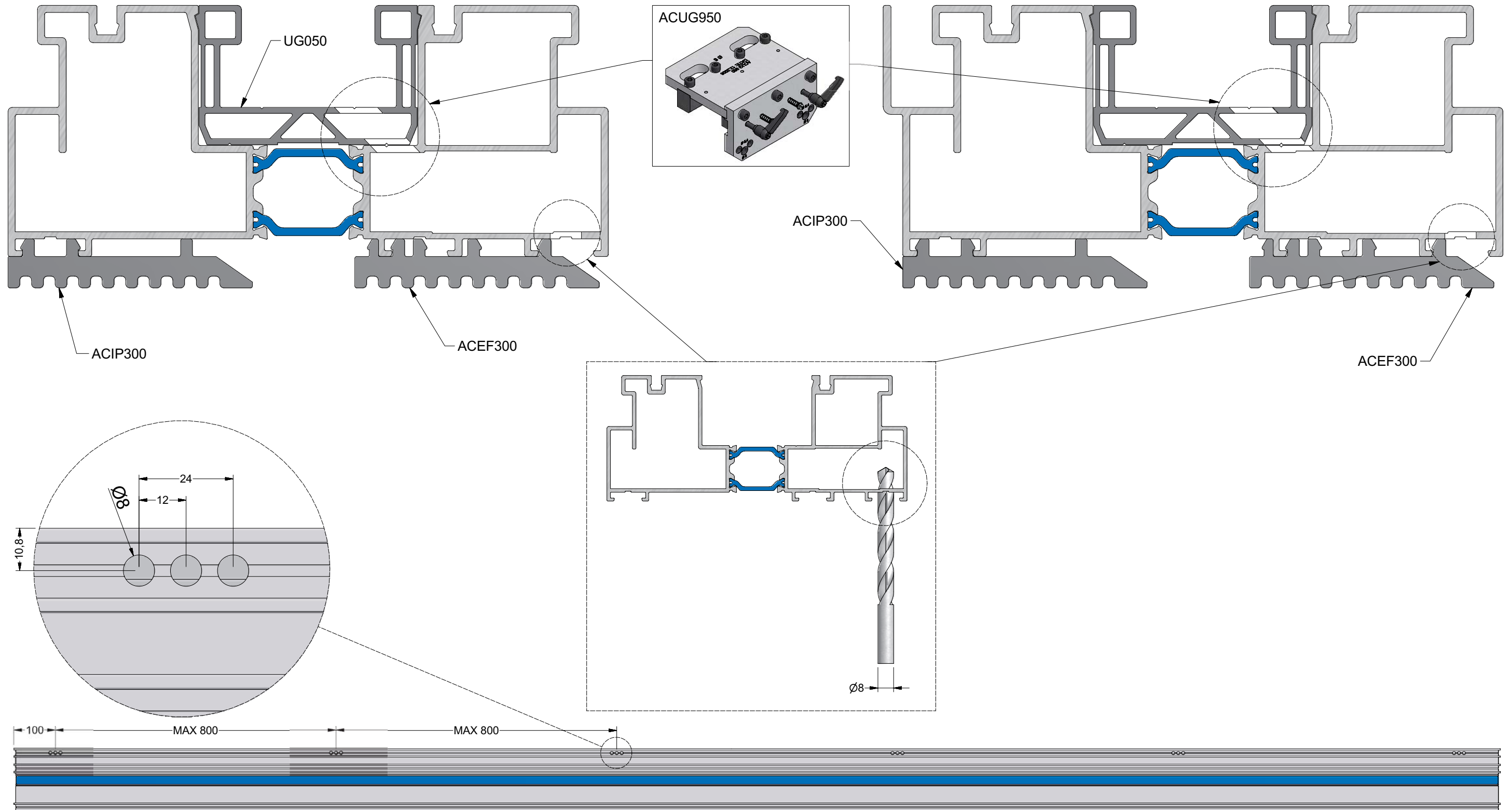

VERDOKEN AFWATERING UG010 - UG110.idw

WERKTEKENINGEN - DESSINS DE CONSTRUCTION - KONSTRUKTIONZEICHNUNGEN - CONSTRUCTION DRAWINGS

ONTLUCHTING EN ONTWATERING VLEUGEL
VENTILATION ET DRAINAGE OUVRANT
ENTLÜFTUNG UND ENTWASSERUNG FLUGELPROFILE
VENTILATION AND DRAINING VENT PROFILE

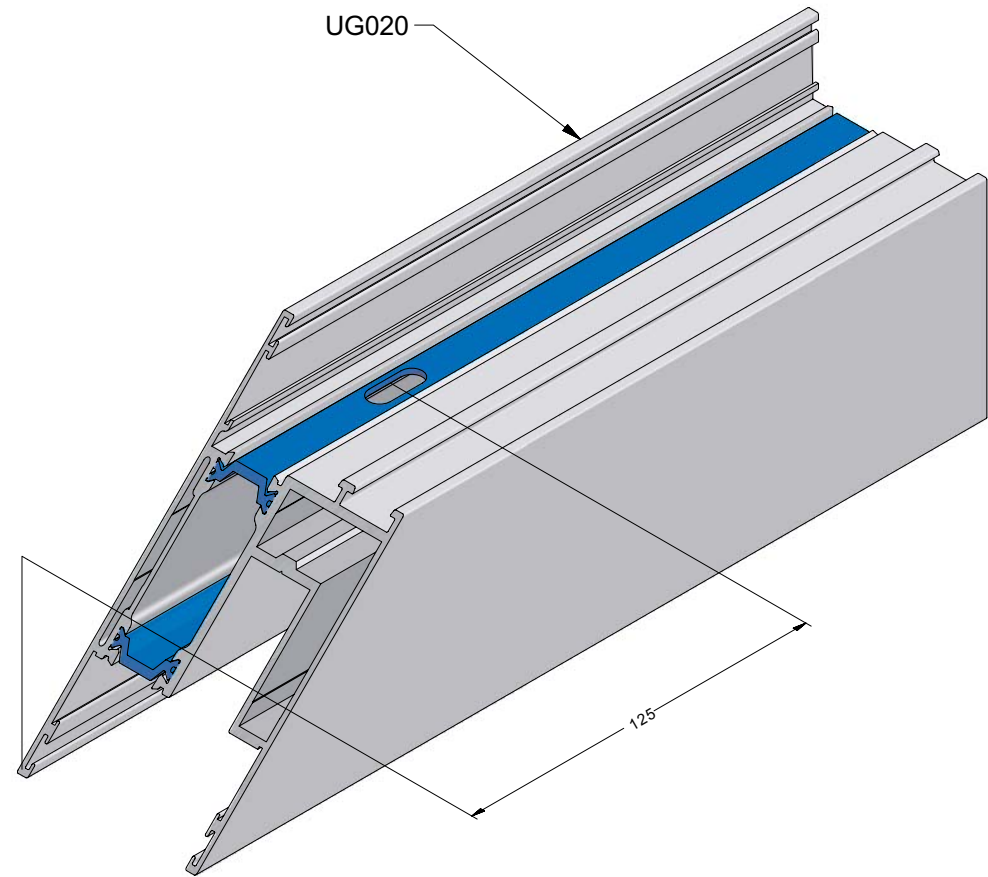
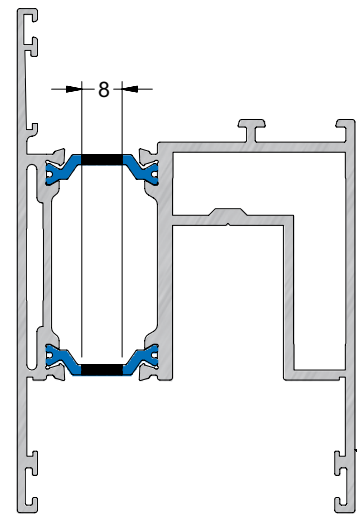
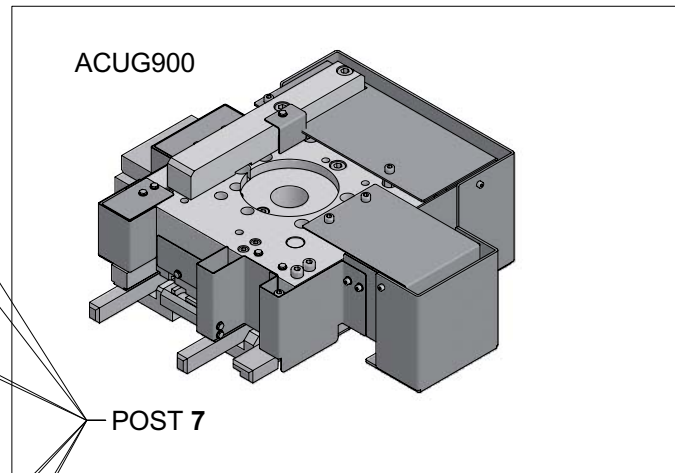
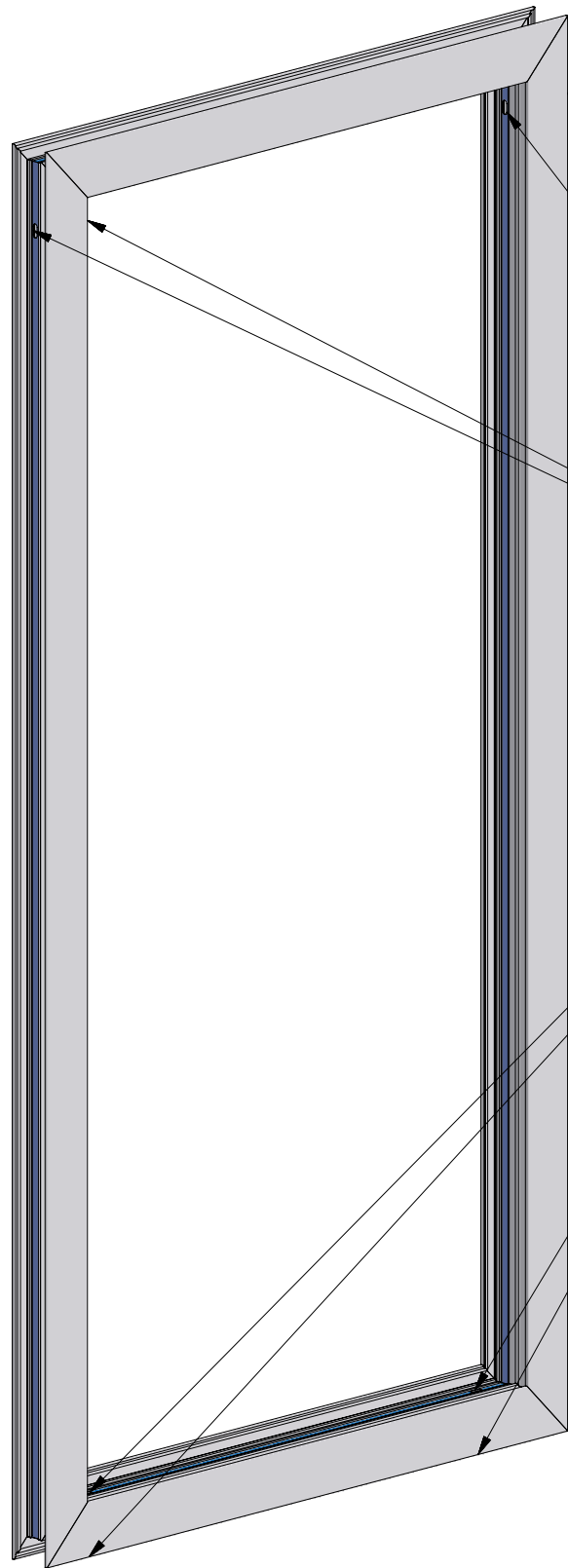

ONTLUCHTING EN ONTWATERING VLEUGEL.idw

ONTLUCHTING VAST RAAM MONORAIL
VENTILATION CHASSIS FIXE MONORAIL
ENTLUFTUNG FEST FELD MONORAIL
VENTILATION FIXED WINDOW MONORAIL

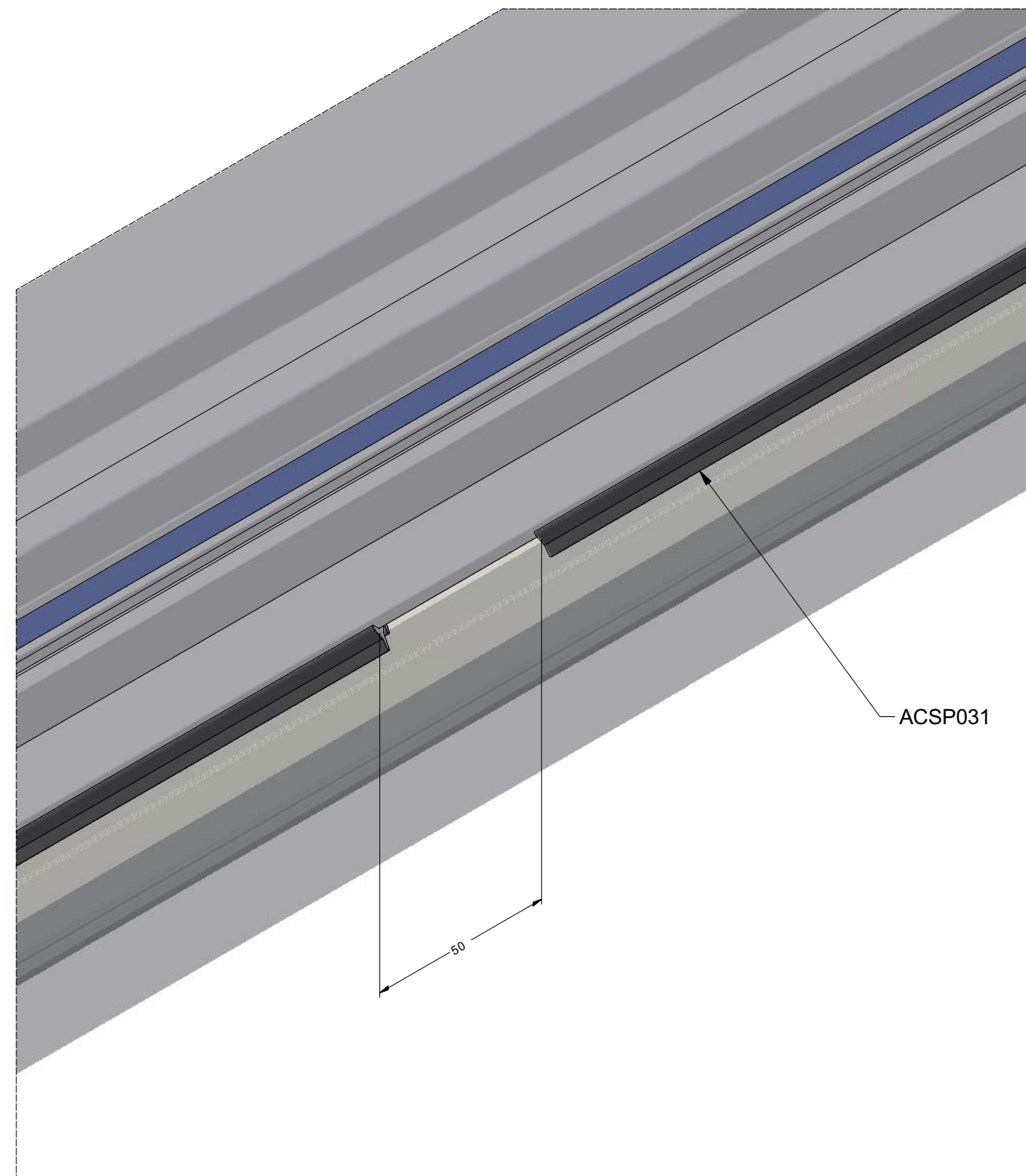
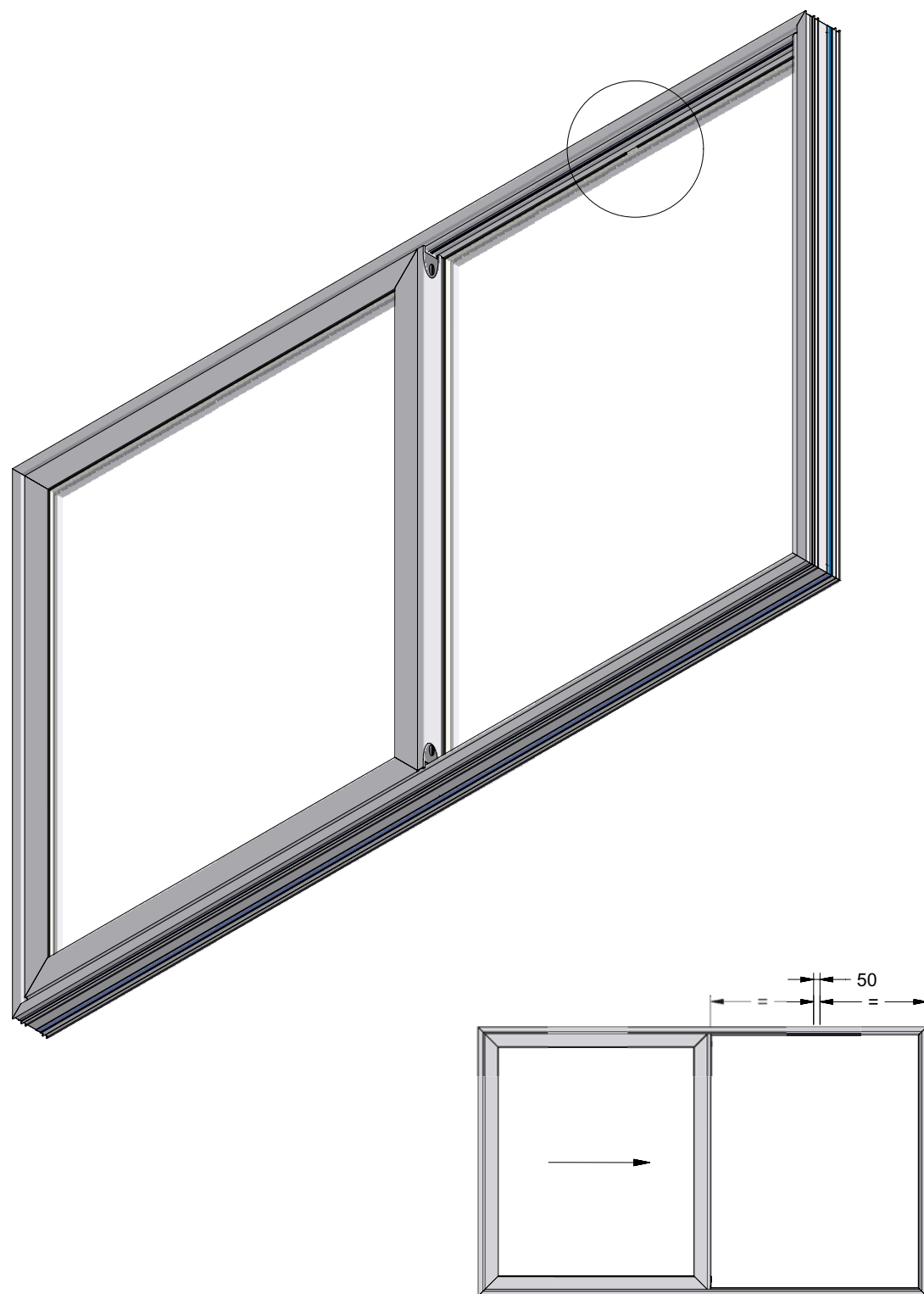

ONTLUCHTING VAST RAAM MONORAIL.idw

ONTWATERING UG050 - VLEUGEL BUITEN
 DRAINAGE UG050 - OUVRANT EXTERIEUR
 ENTWASSERUNG UG050 - FLUGELPROFILE AUSSEN
 DRAINING UG050 - VENT PROFILE OUTSIDE

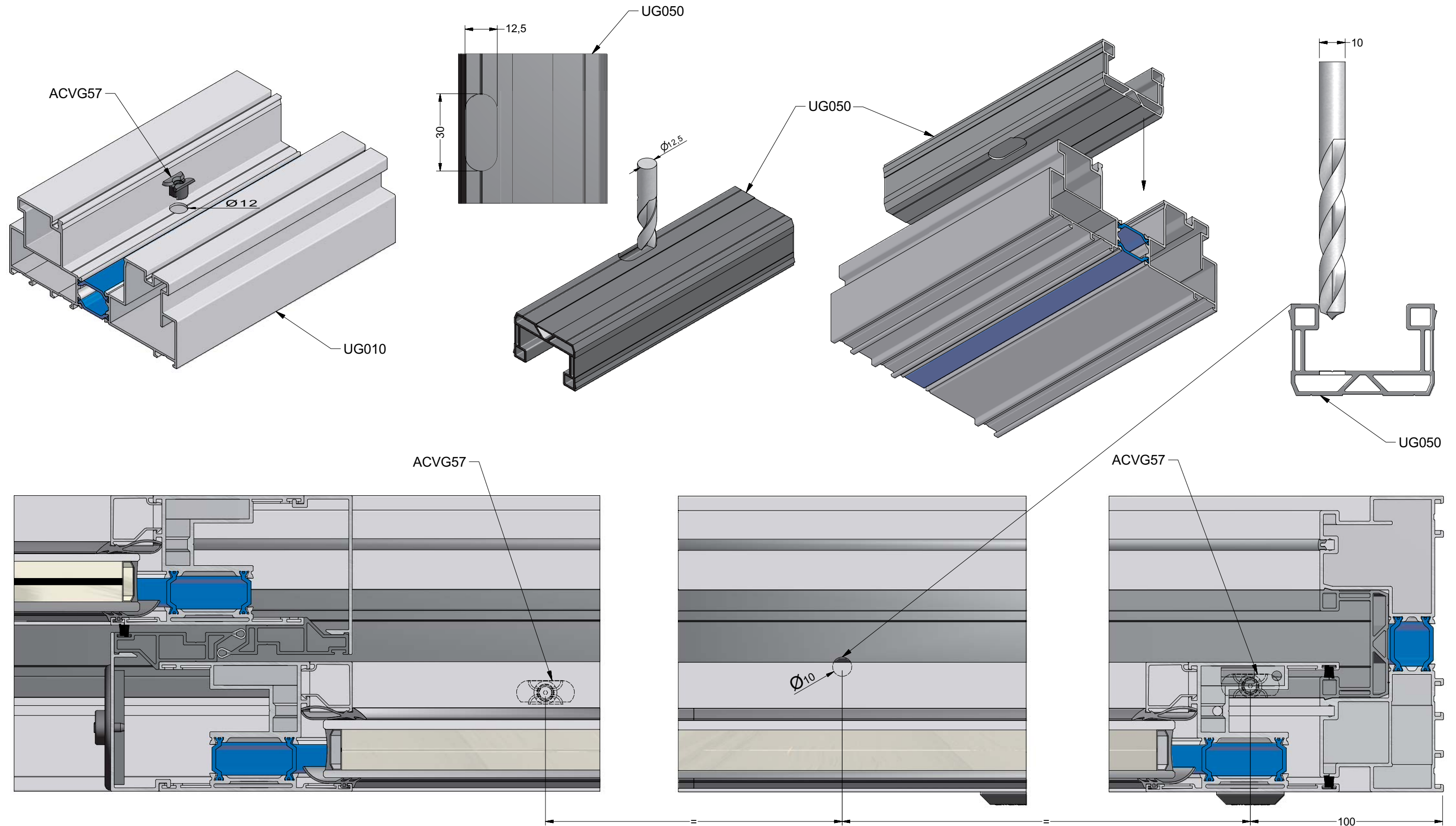

ONTWATERING GOOT → VLEUGEL BUITEN.idw

ONTWATERING UG050 - VLEUGEL BINNEN
 DRAINAGE UG050 - OUVRANT INTERIEUR
 ENTWASSERUNG UG050 - FLUGELPROFILE INNEN
 DRAINING UG050 - VENT PROFILE INSIDE

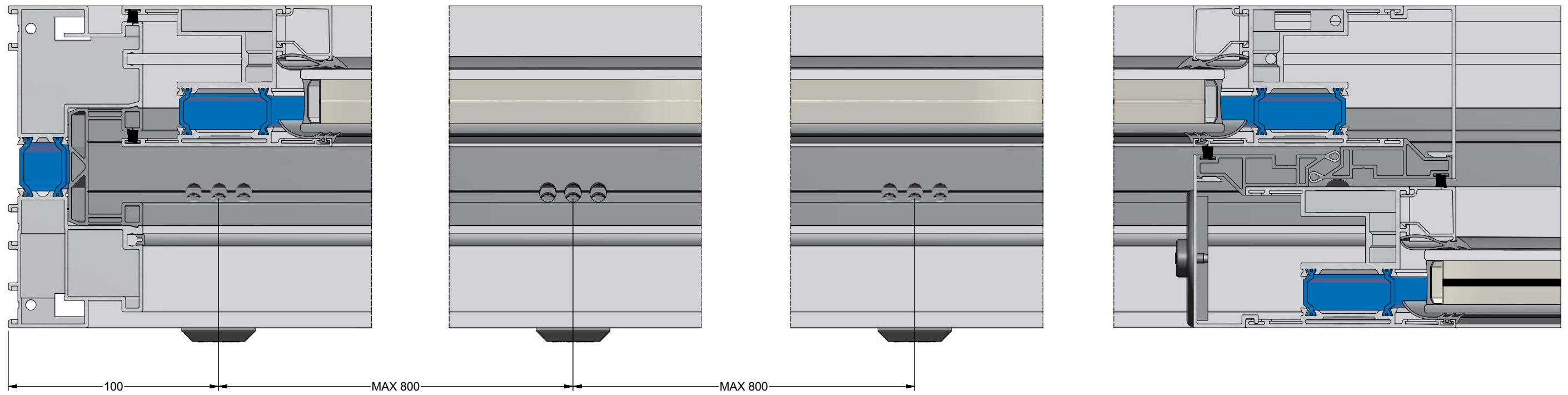
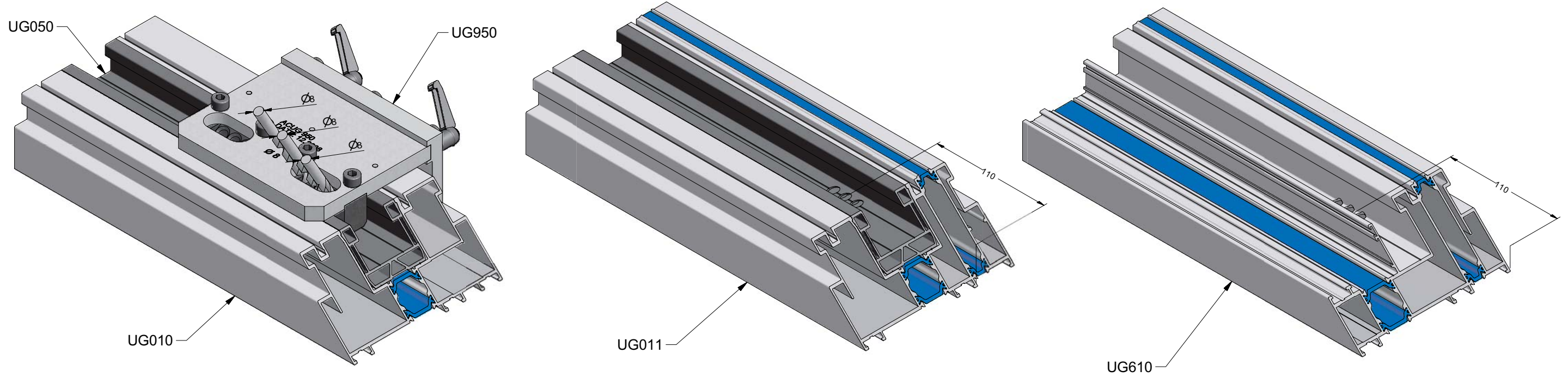

ONTWATERING GOOT → VLEUGEL BINNEN.idw

WERKTEKENINGEN - DESSINS DE CONSTRUCTION - KONSTRUKTIONZEICHNUNGEN - CONSTRUCTION DRAWINGS

MONTAGE SLOT IN UG141
 MONTAGE SERRURE EN UG141
 MONTAGE SCHLOSS IN UG141
 MONTAGE LOCK IN UG141

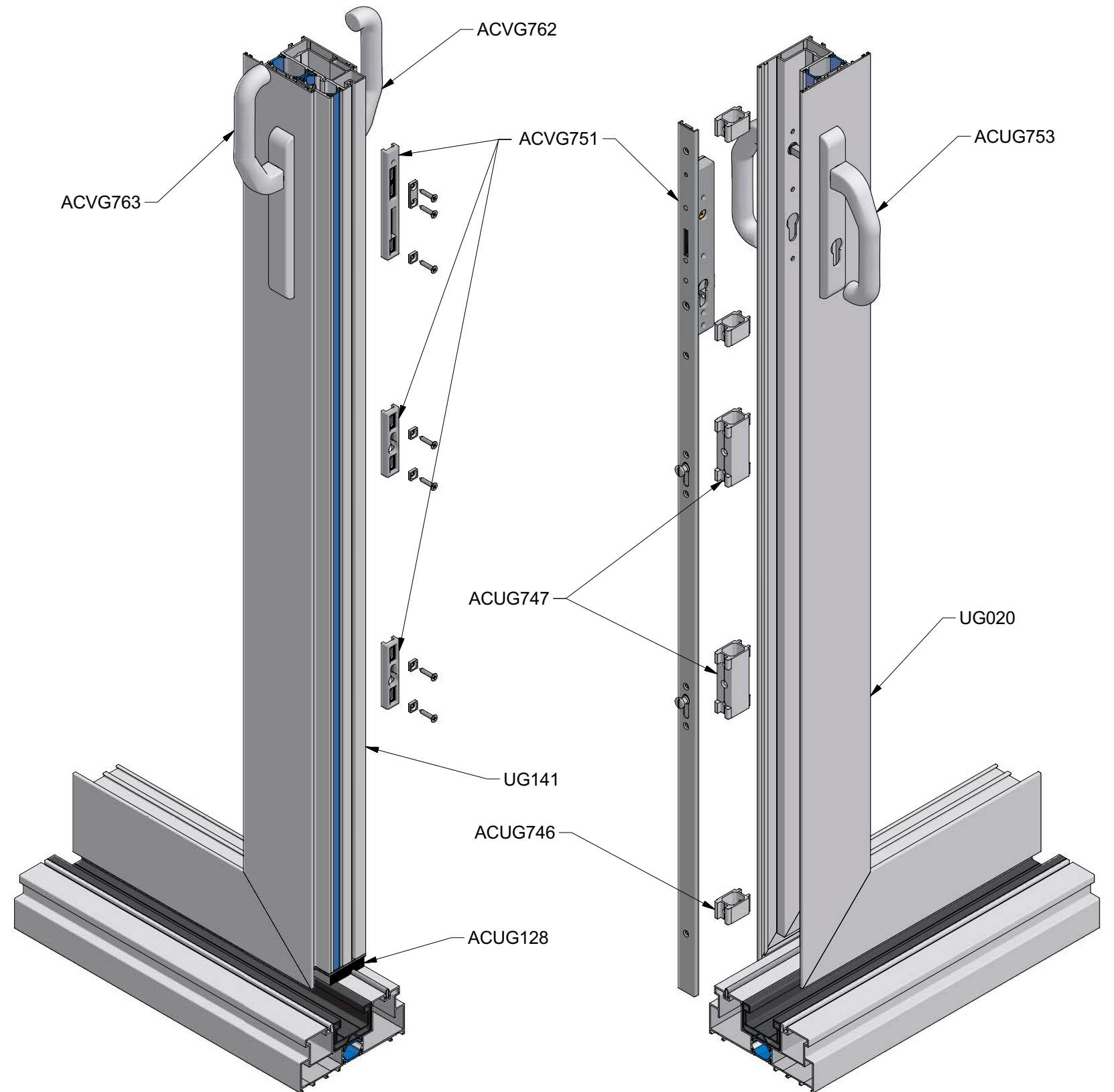
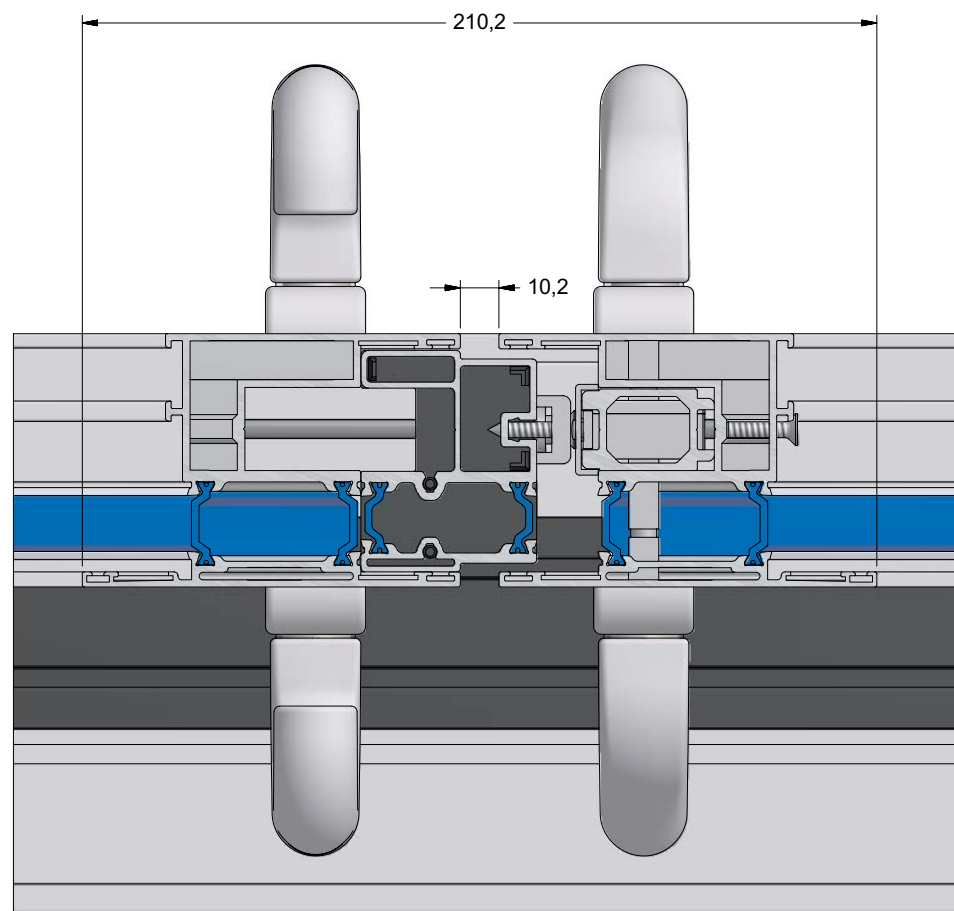
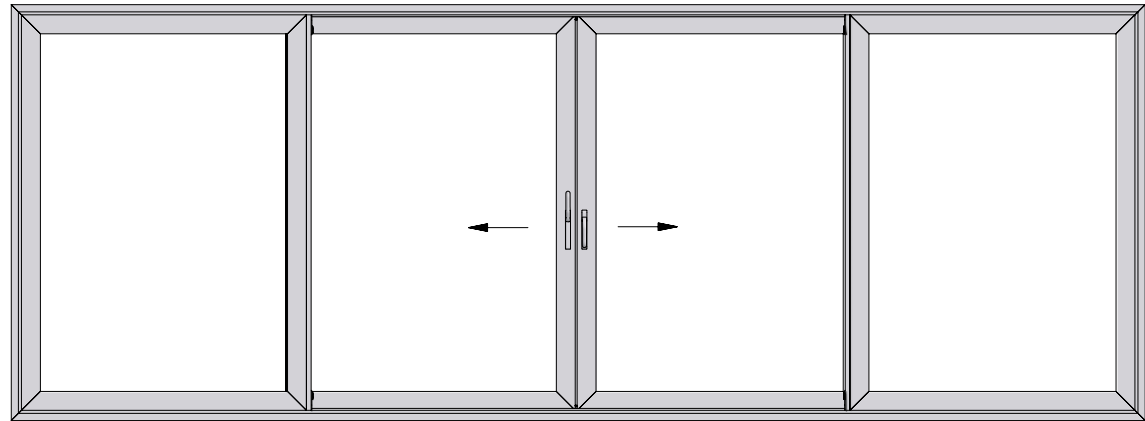

PLAATSING SLOT IN UG141.idw

MONTAGE ACUG553 + ACVG554
 MONTAGE ACUG553 + ACVG554
 MONTAGE ACUG553 + ACVG554
 MONTAGE ACUG553 + ACVG554

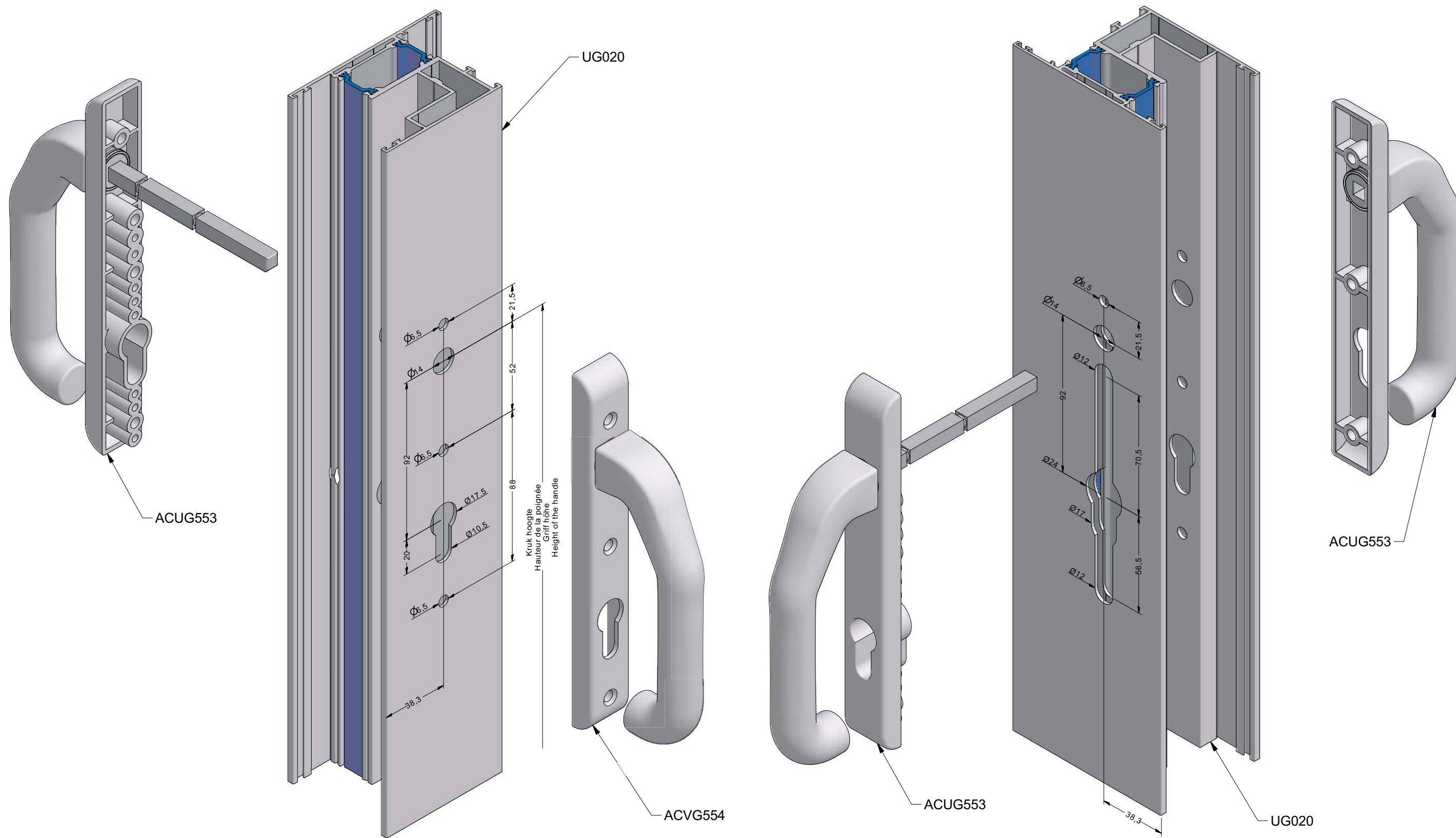

MONTAGE ACUG553 + ACVG554.idw

MONTAGE ACUG753 + ACVG754
 MONTAGE ACUG753 + ACVG754
 MONTAGE ACUG753 + ACVG754
 MONTAGE ACUG753 + ACVG754

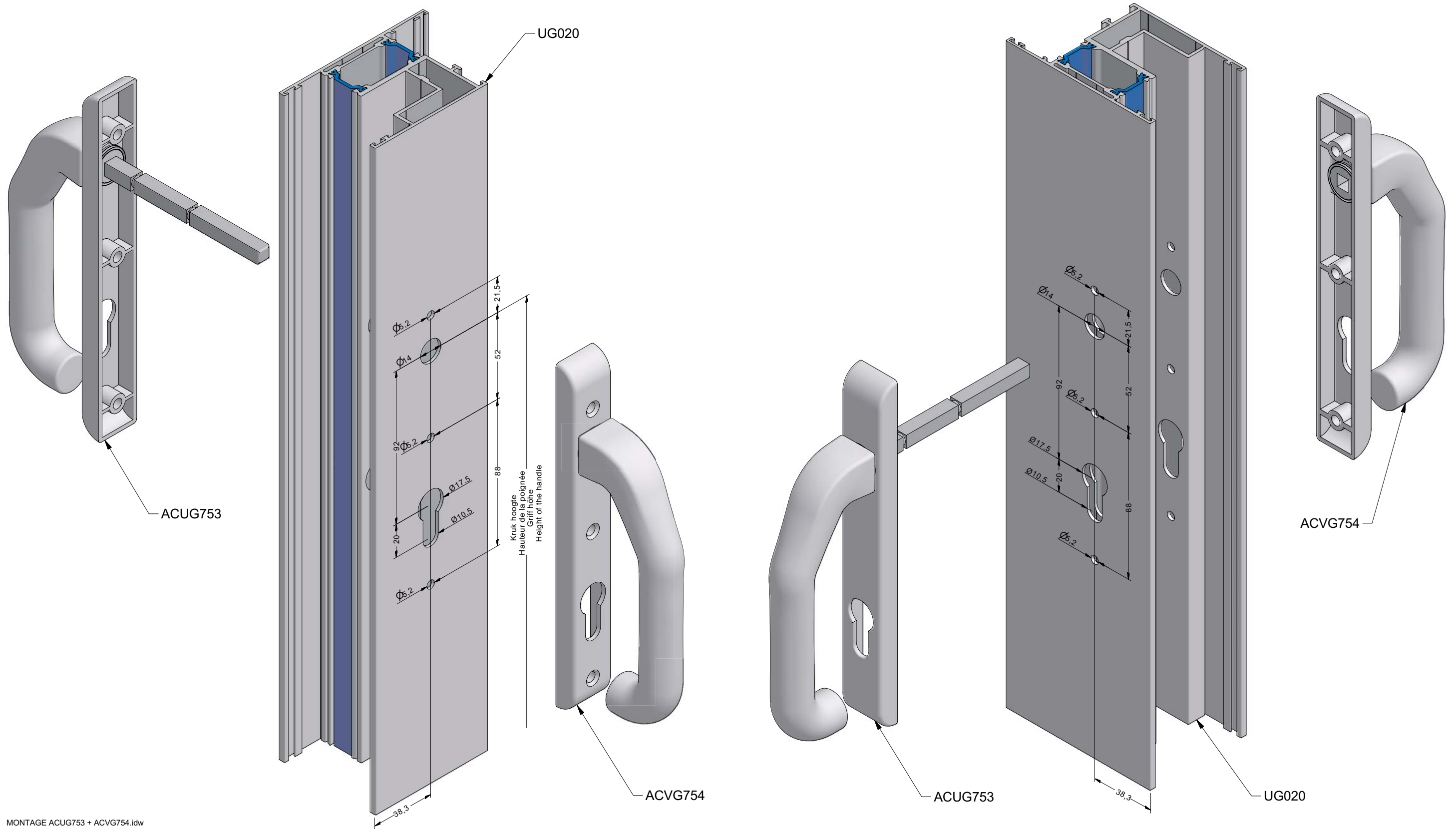

MONTAGE ACUG753 + ACVG754.idw

MONTAGE ACUG757 + ACVG758
 MONTAGE ACUG757 + ACVG758
 MONTAGE ACUG757 + ACVG758
 MONTAGE ACUG757 + ACVG758

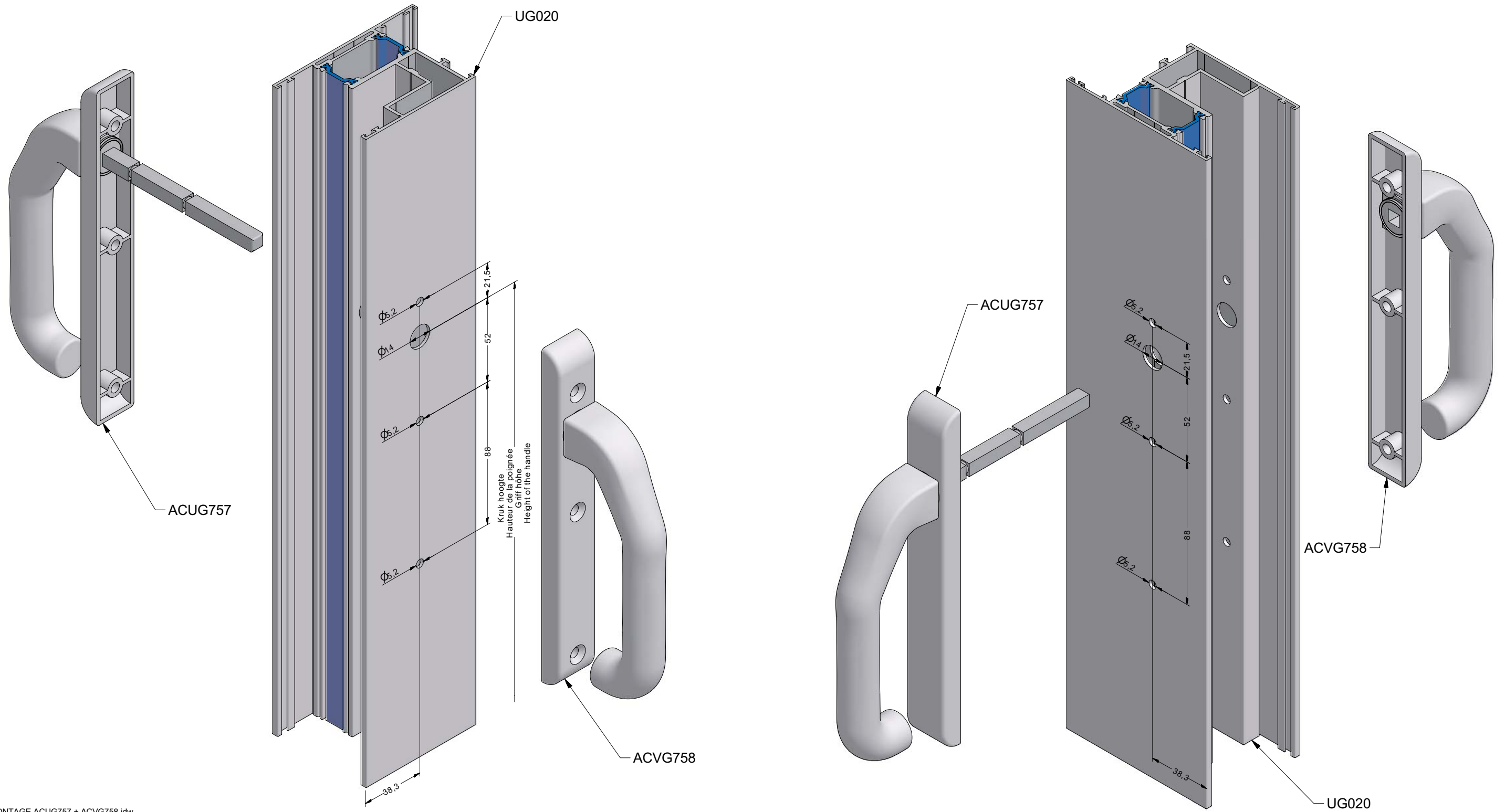

MONTAGE ACUG757 + ACVG758.idw

MONTAGE ACUG759 + ACVG762
 MONTAGE ACUG759 + ACVG762
 MONTAGE ACUG759 + ACVG762
 MONTAGE ACUG759 + ACVG762

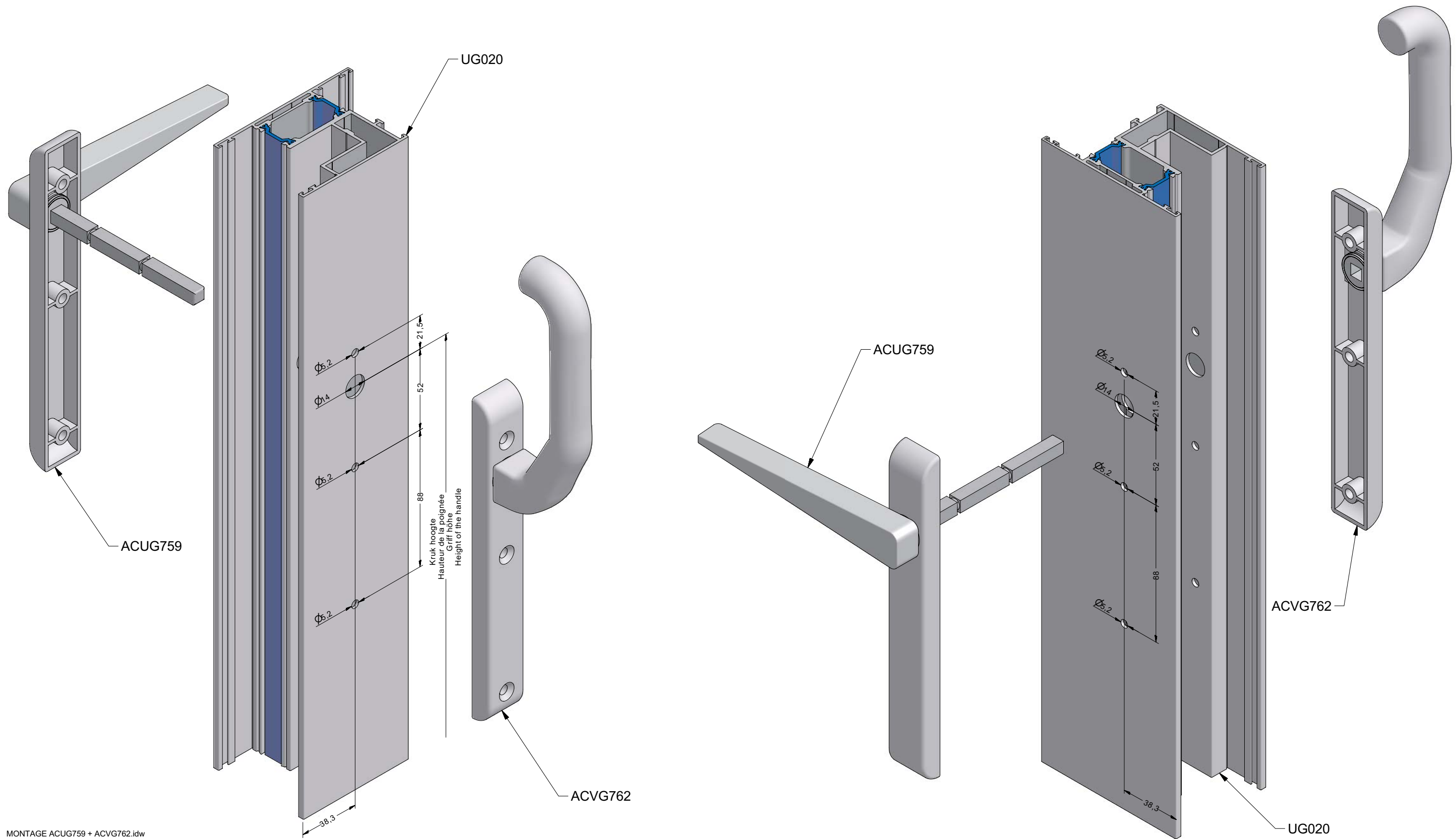

MONTAGE ACUG759 + ACVG762.idw

WERKTEKENINGEN - DESSINS DE CONSTRUCTION - KONSTRUKTIONZEICHNUNGEN - CONSTRUCTION DRAWINGS

MONTAGE ACUG760 + ACVG754
 MONTAGE ACUG760 + ACVG754
 MONTAGE ACUG760 + ACVG754
 MONTAGE ACUG760 + ACVG754

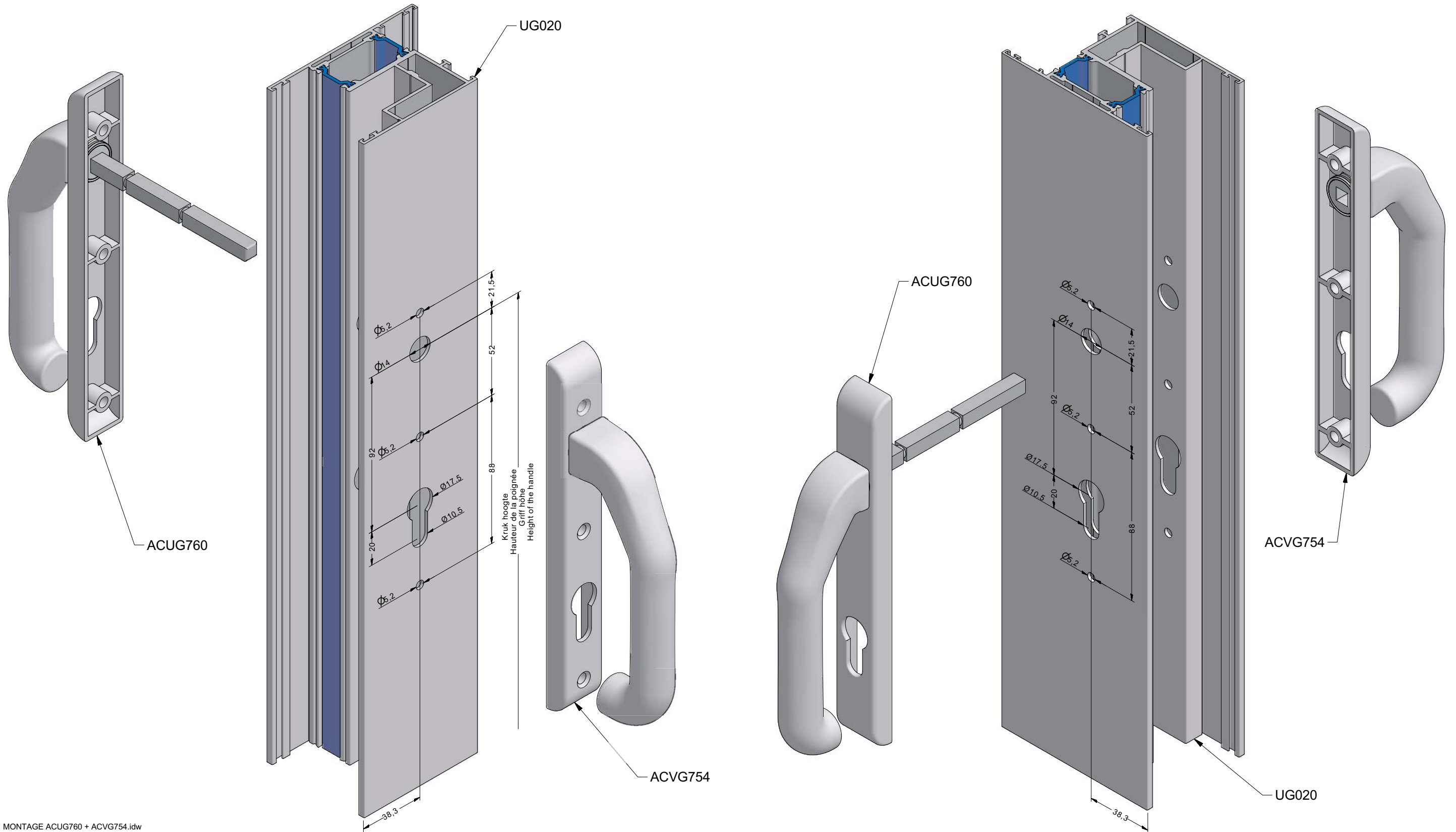

MONTAGE ACUG760 + ACVG754.idw

MONTAGE ACUG761 + ACVG754
 MONTAGE ACUG761 + ACVG754
 MONTAGE ACUG761 + ACVG754
 MONTAGE ACUG761 + ACVG754

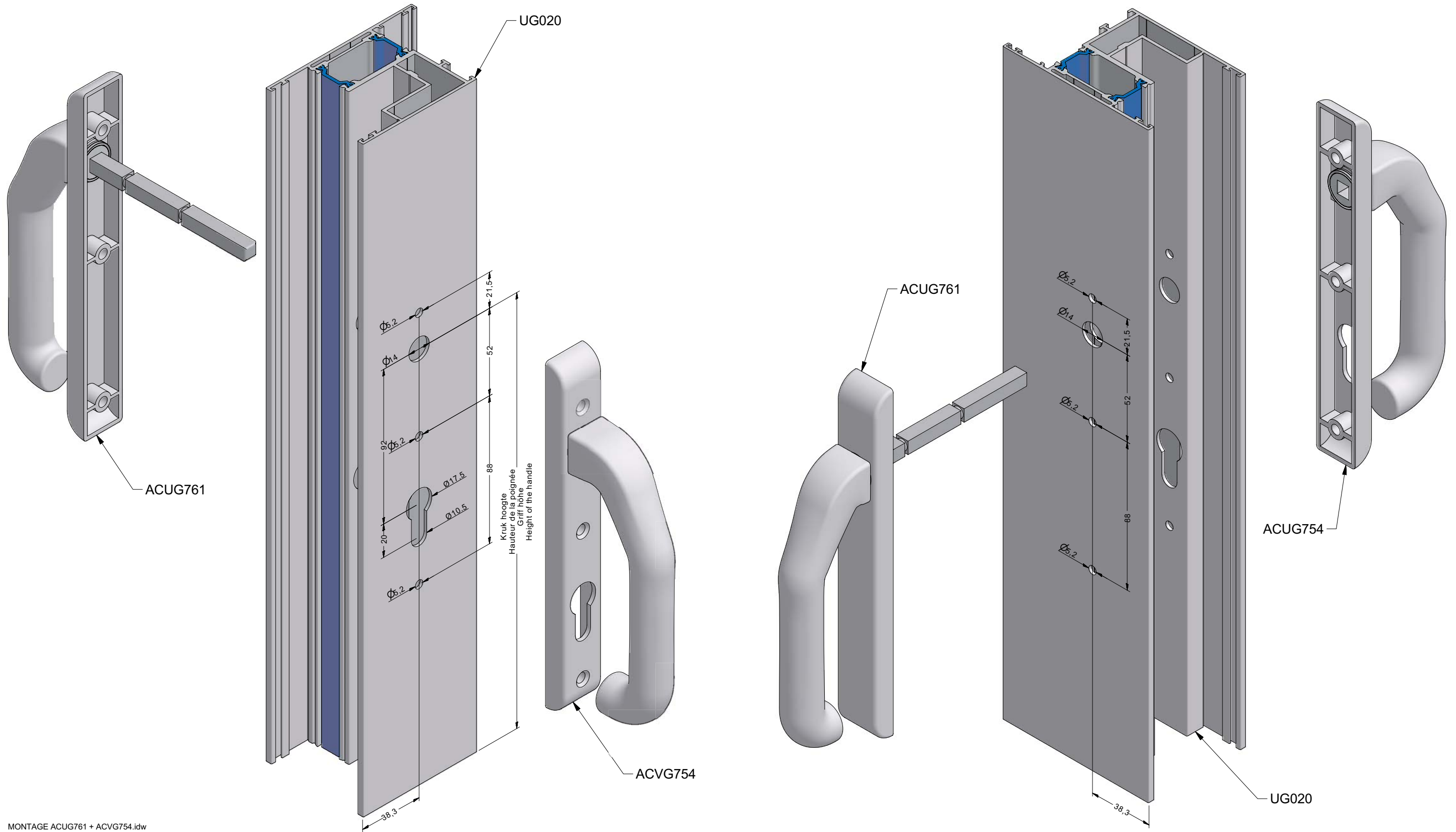

MONTAGE ACUG761 + ACVG754.idw

WERKTEKENINGEN - DESSINS DE CONSTRUCTION - KONSTRUKTIONZEICHNUNGEN - CONSTRUCTION DRAWINGS

MONTAGE ACVG763 + ACVG762
MONTAGE ACVG763 + ACVG762
MONTAGE ACVG763 + ACVG762
MONTAGE ACVG763 + ACVG762

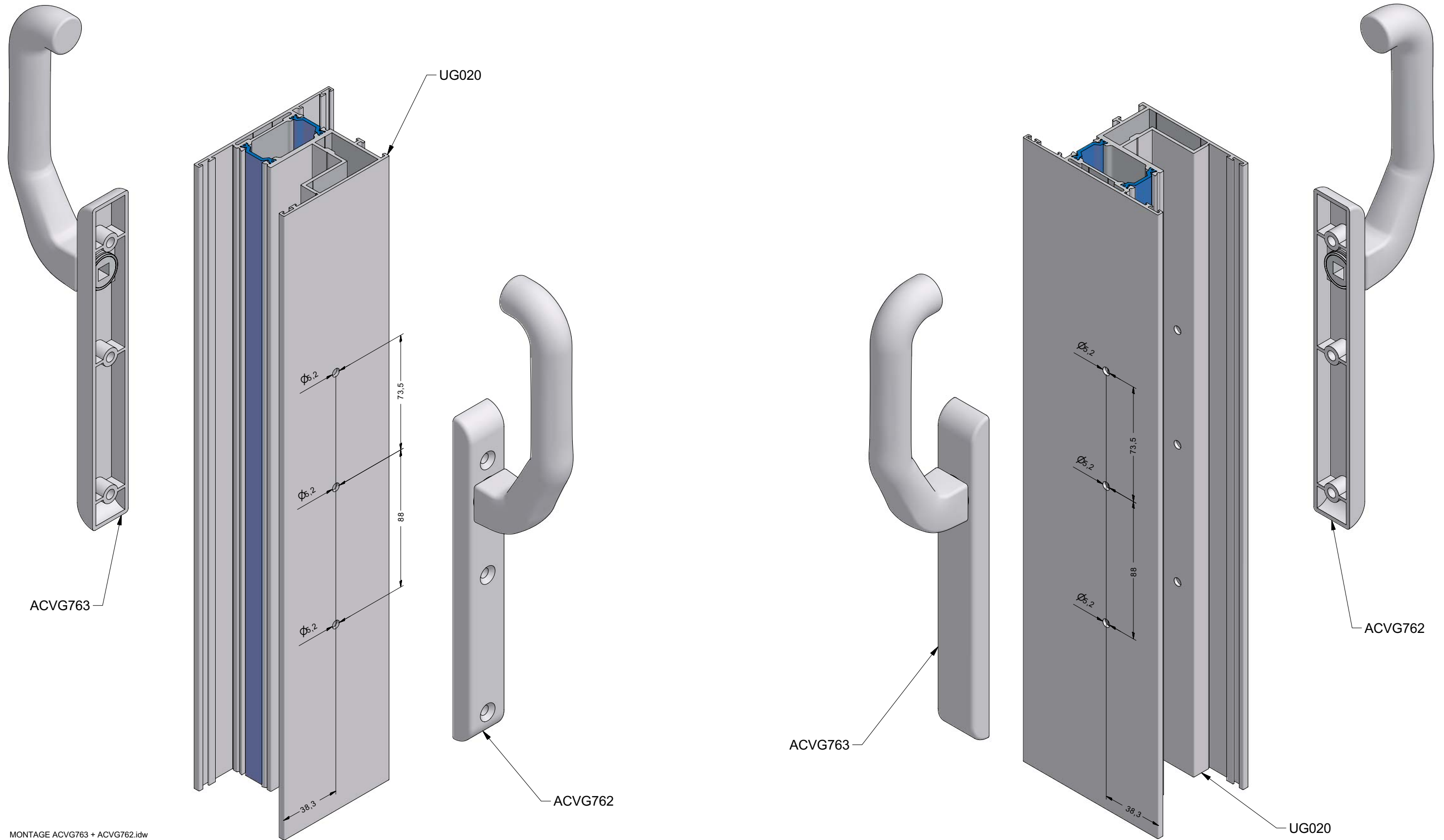

MONTAGE ACVG763 + ACVG762.idw

MONTAGE ACVG764 + ACVG754
 MONTAGE ACVG764 + ACVG754
 MONTAGE ACVG764 + ACVG754
 MONTAGE ACVG764 + ACVG754

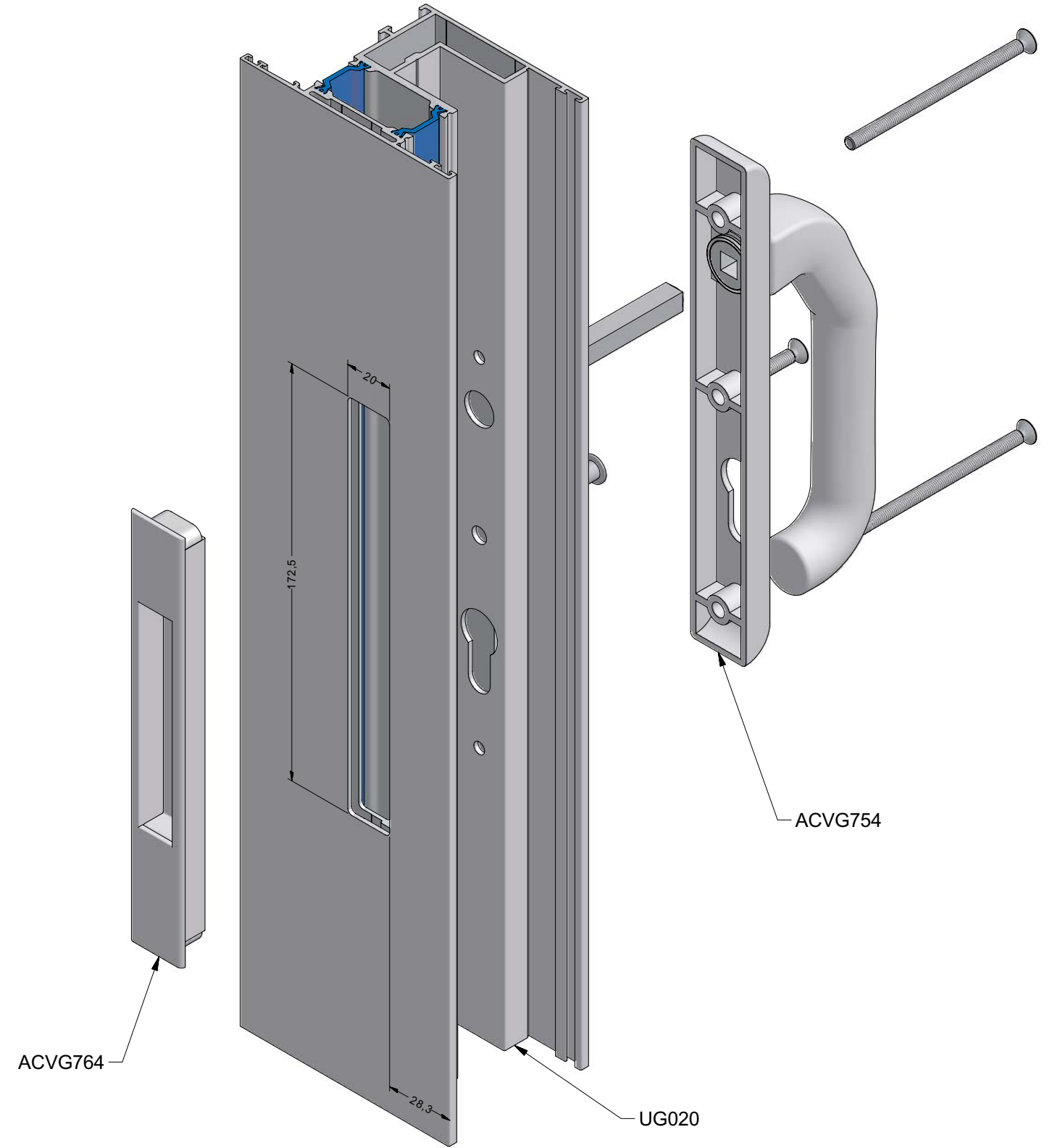
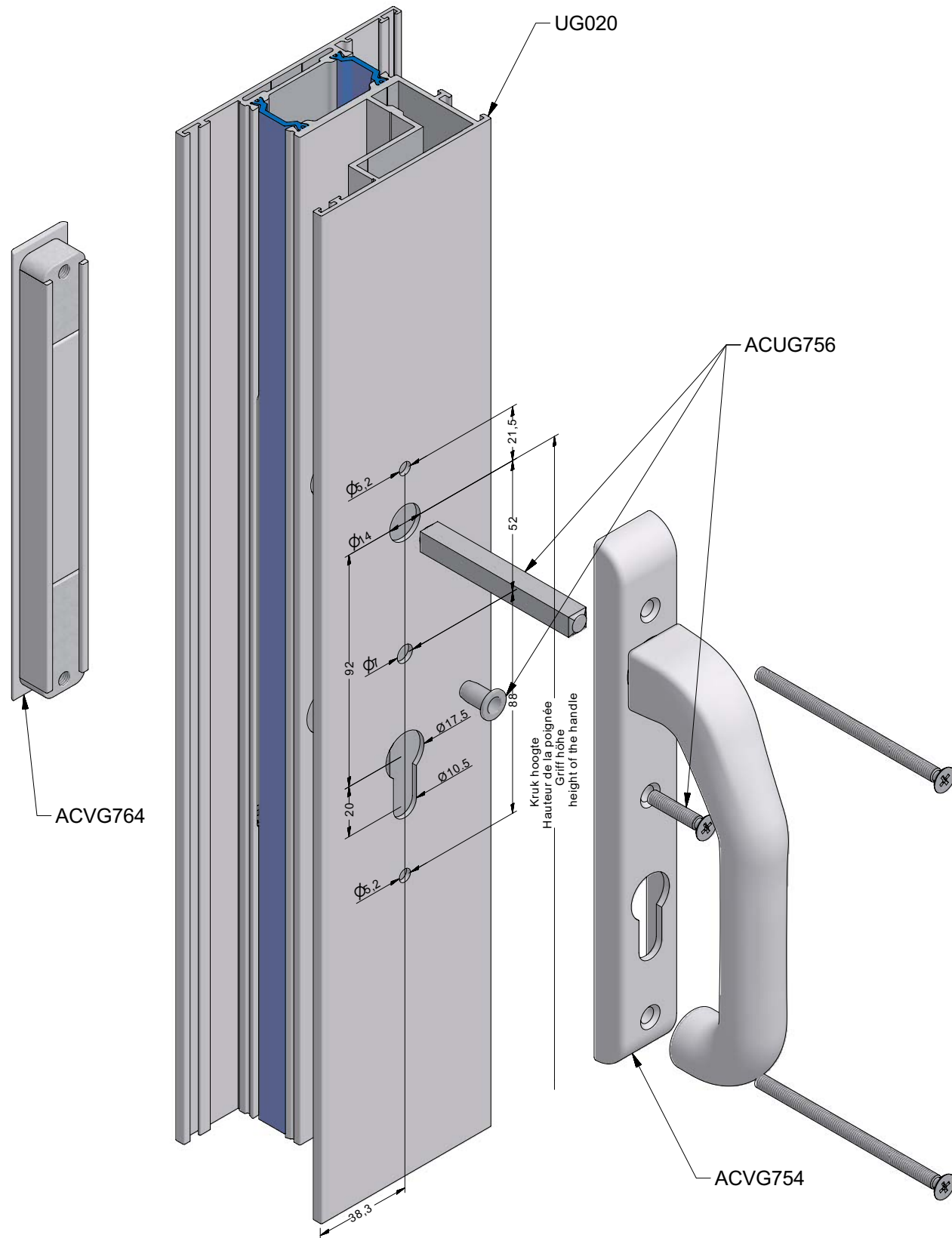

MONTAGE ACVG764 + ACVG754.idw

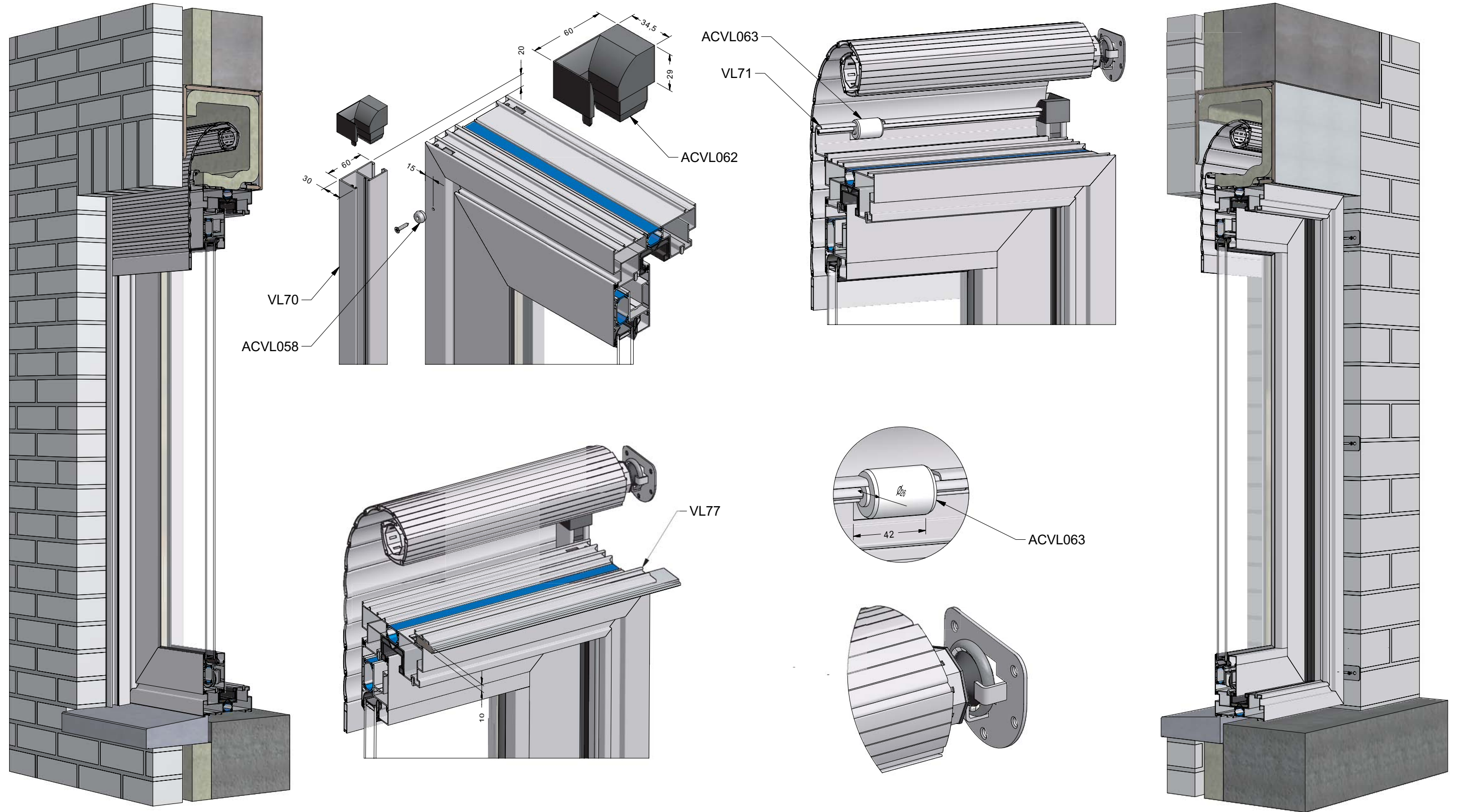

MONTAGE ROLLUIK.idw

MUURAANSLUITING UG110 - UG111
RACCORD MACONNERIE UG110 - UG111
BAUANSCHLUSS UG110 - UG111
BUILDING CONNECTION UG110 - UG111

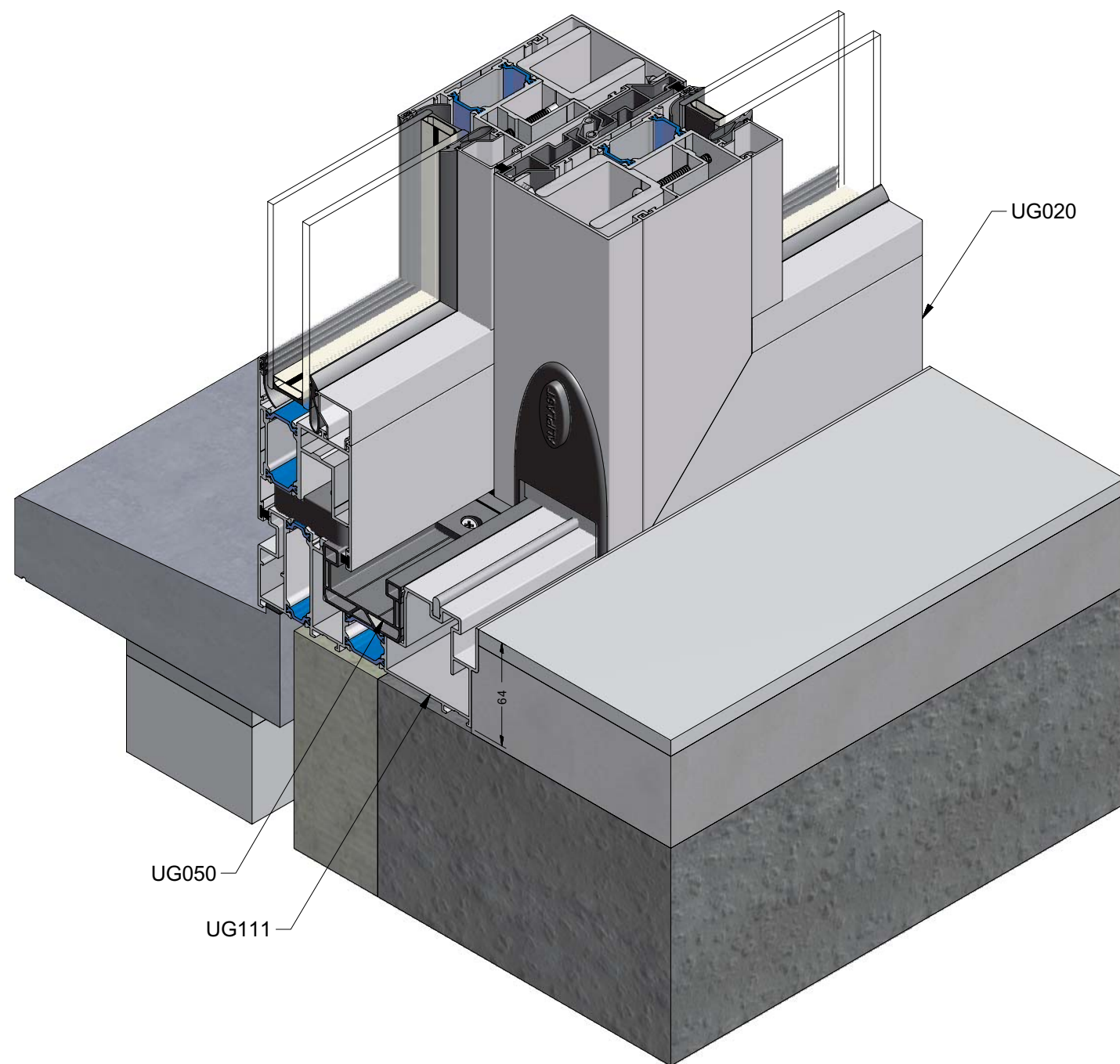
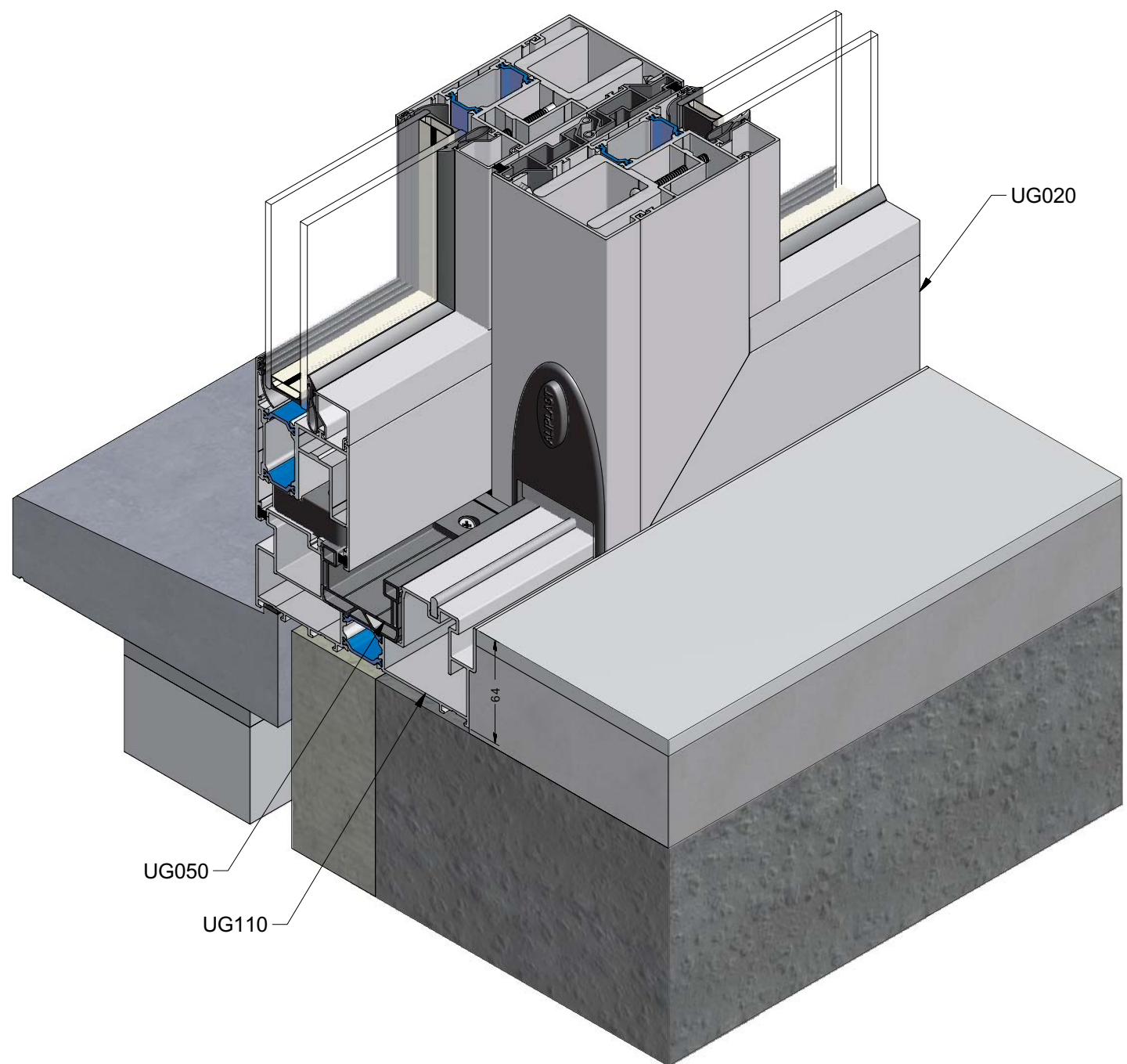

INBOUWVOORBEELD UG110 - UG111.idw

MUURAANSLUITING UG112 - UG113
RACCORD MACONNERIE UG112 - UG113
BAUANSCHLUSS UG112 - UG113
BUILDING CONNECTION UG112 - UG113

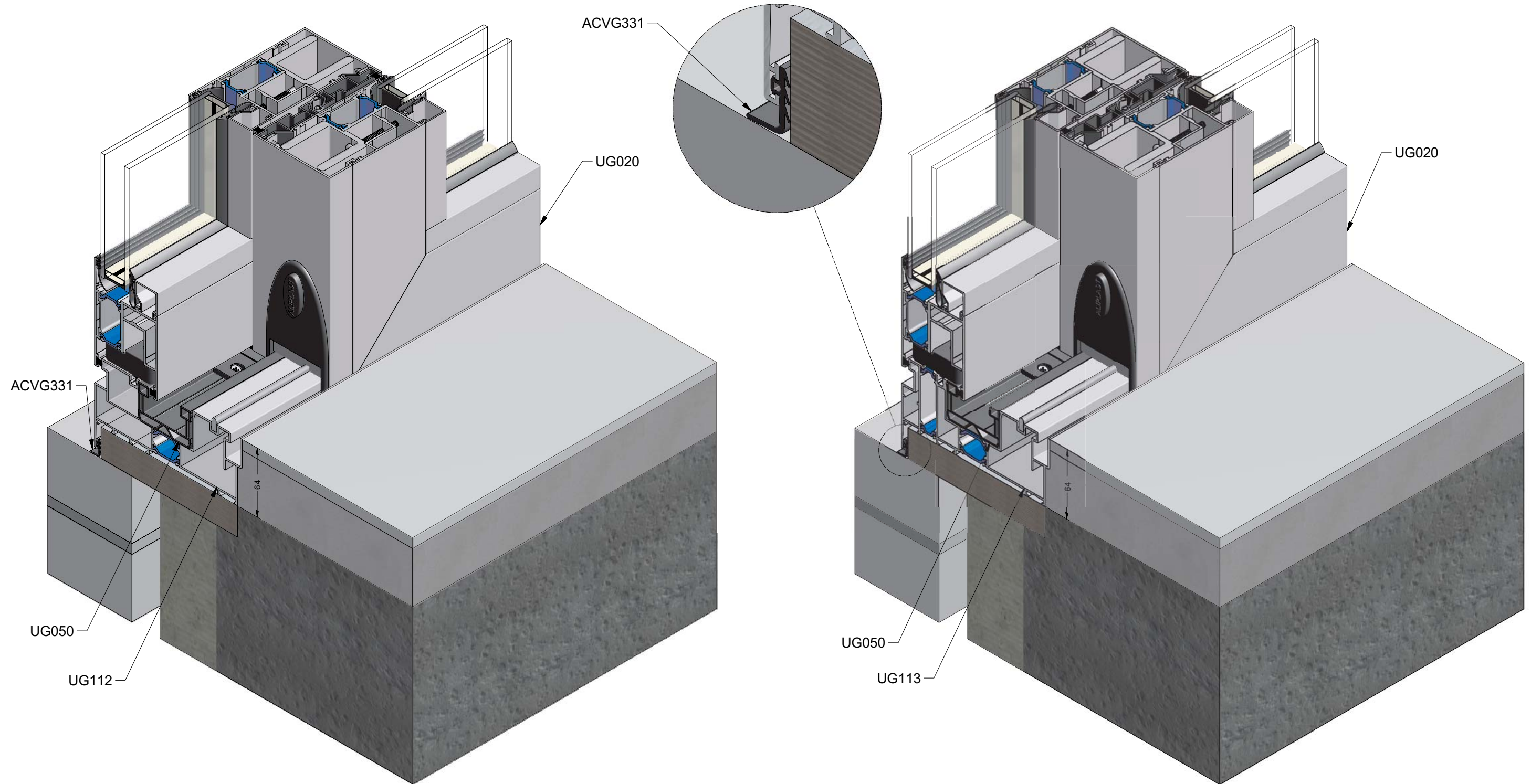

INBOUWVOORBEELD UG112 - UG113.idw

SCHEMA HEFSCHUIF BESLAG
 SCHEMA LEVANT COULISSANT QUINCAILLERIE
 SCHEMA HEBESCHIEBE BESCHLAG
 SCHEME LIFT SLIDING HARDWARE

HEFSCHUIFRAMEN / FENETRES LEVANT COULISSANTES
 HEBESCHIEBEFENSTER / LIFT SLIDING PATIODOOR

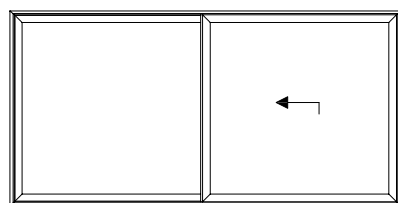

SCHEMA A

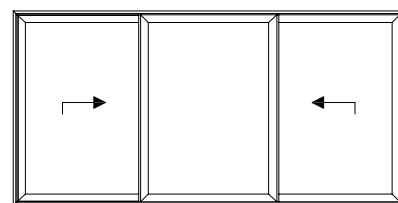

SCHEMA C

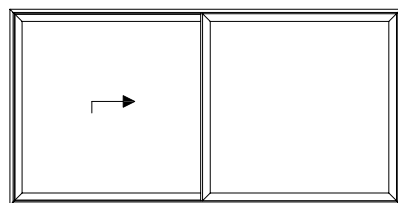

SCHEMA A

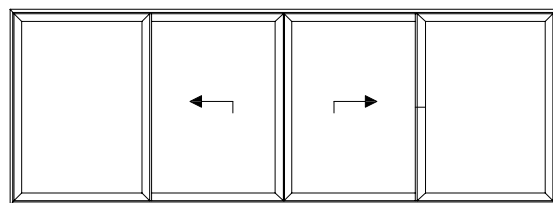

SCHEMA D

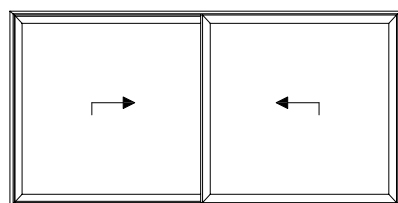

SCHEMA B

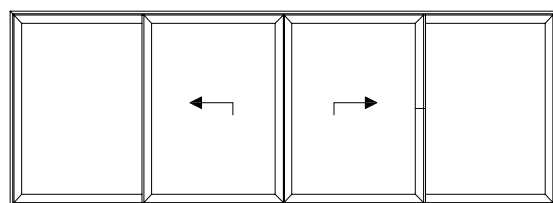

SCHEMA D

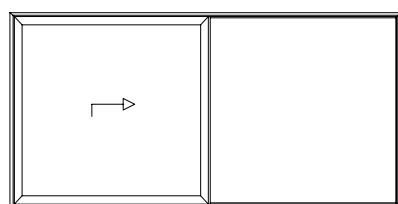

SCHEMA A

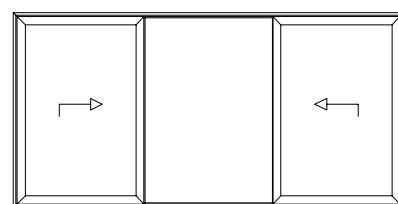

SCHEMA C

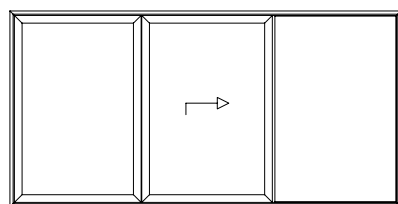

SCHEMA E

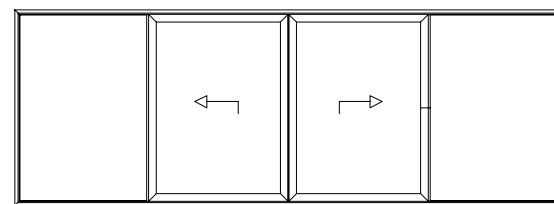

SCHEMA D

MONORAIL HEFSCHUIF / MONORAIL LEVANT COULISSANTES
 MONORAIL HEBESCHIEBE / MONORAIL LIFT SLIDING

SCHEMA_HEF-SCHUIF

AANTAL/SCHEMA NOMBRE/SCHEMA ANZAHL/SCHEMA NUMBER/SCHEME					OMSCHRIJVING DESCRIPTION BESCHREIBUNG DESCRIPTION	NUMMER NUMERO NUMMER NUMBER
A	B	C	D	E		
1	2	2	2	1	-SLOTOVERBRENGING -TRANSMISSION DE SERRURE -GETRIEBE -ESPAG VLEUGELHOOGTE HAUTEUR D'OUVRANT FLUGEL HOHE VENT HEIGHT 1343 mm - 1942 mm 1943 mm - 2242 mm 2243 mm - 2542 mm 2543 mm - 2842 mm	ACUG200 ACUG201 ACUG202 ACUG203
1	2	2	2	1	-BASISPAKKET HEFSCHUIF EXCLUSIVE -PAQUET DE BASE LEVANT COULISSANT EXCLUSIVE -GRUNDKARTON HEBESCHIEBE EXCLUSIVE -BASIC SET LIFT SLIDING EXCLUSIVE	ACUG210
OPTIONEEL OPTIONNEL FACULTATIEF OPTIONAL					-GRENDEL PINNEN -VERROU GOUPILLES -RIEGELBOLZEN -BOLT PINS	ACUG220
			1		-VERGRENDELING ONDERKANT -VERROUILLAGE DESSOUS -VERRIEGELUNG UNTERSEITE -LOCKING BOTTOM	ACUG221
1	2	2	2	1	-VERBINDINGSSTANG -BARRE CONNECTION -VERBINDUNGSSTANGE -CONNECTING ROD VLEUGELBREEDTE LARGEUR VANTAIL BREITE FLUGEL WIDTH SASH 894 mm - 1574 mm 1575 mm - 2074 mm 2075 mm - 2574 mm 2464 mm - 3314 mm	ACUG230 ACUG231 ACUG232 ACUG233

WERKTEKENINGEN - DESSINS DE CONSTRUCTION - KONSTRUKTIONZEICHNUNGEN - CONSTRUCTION DRAWINGS

BEWERKINGEN HEFSCHUIF
 OPERATION LEVANT COULISSANT
 OPERATION HEBESCHIEBE
 OPERATION LIFT SLIDING

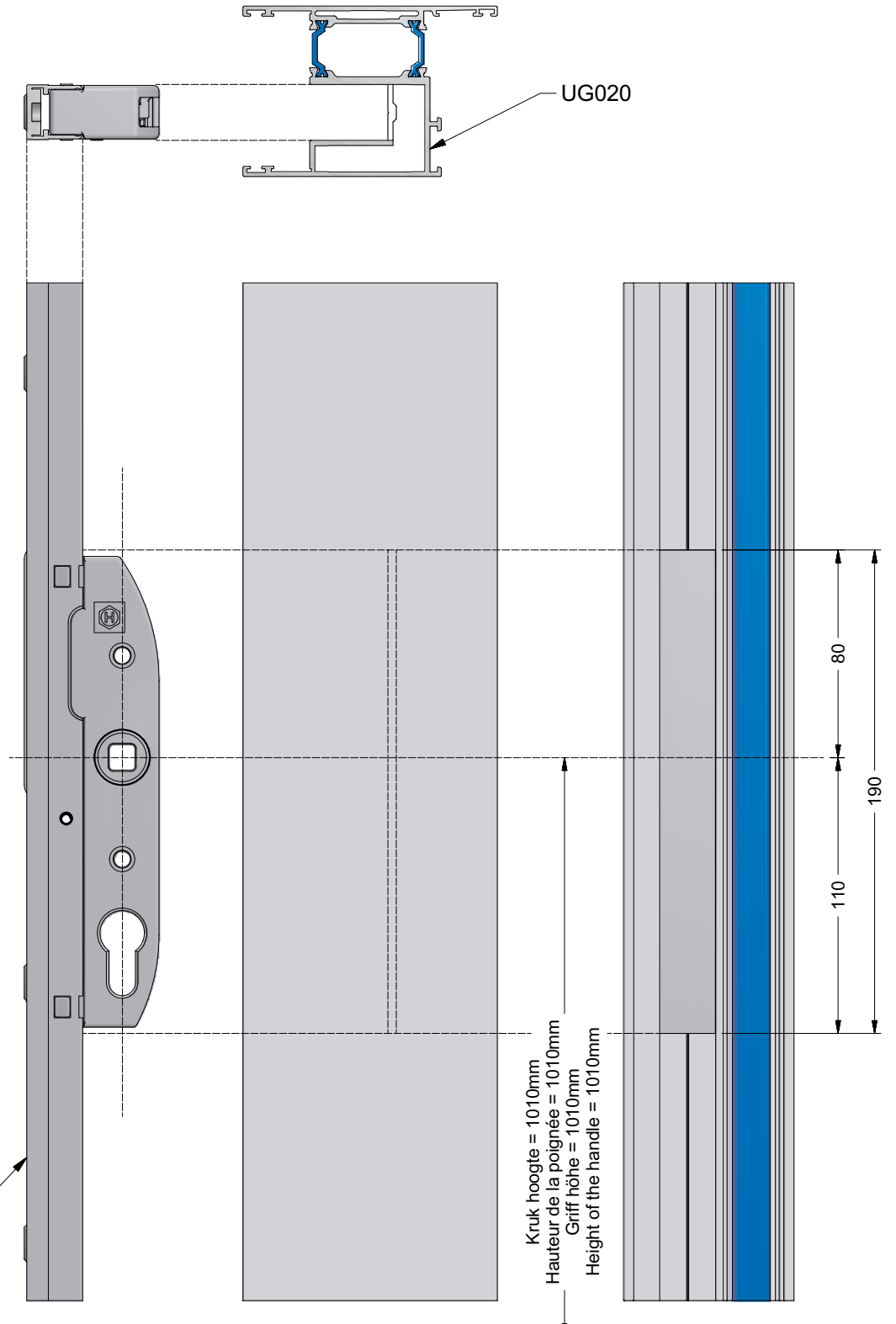
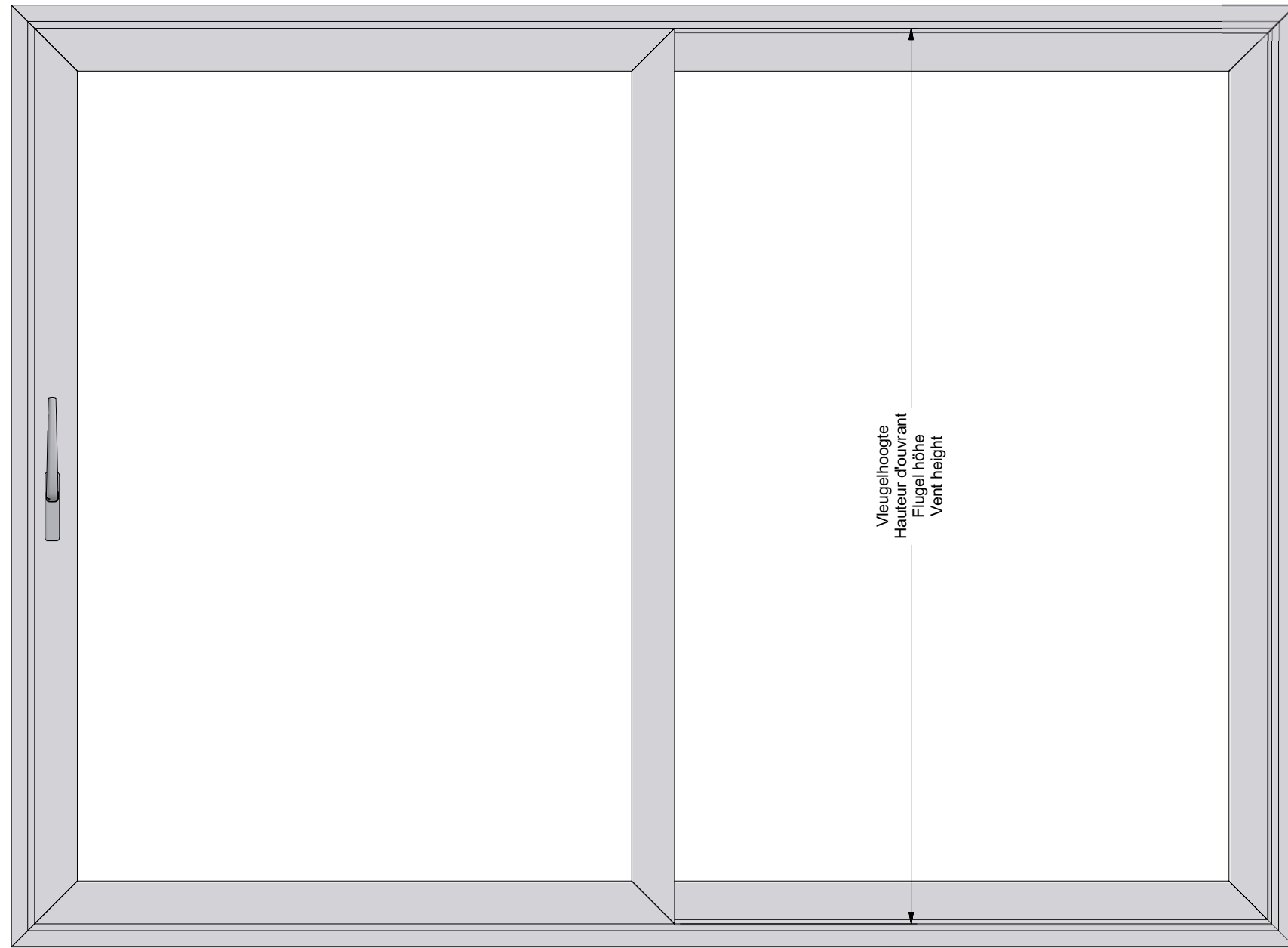

INFREZING SLOT HEFSCHUIF.idw

MONTAGE ACUG286
 MONTAGE ACUG286
 MONTAGE ACUG286
 MONTAGE ACUG286

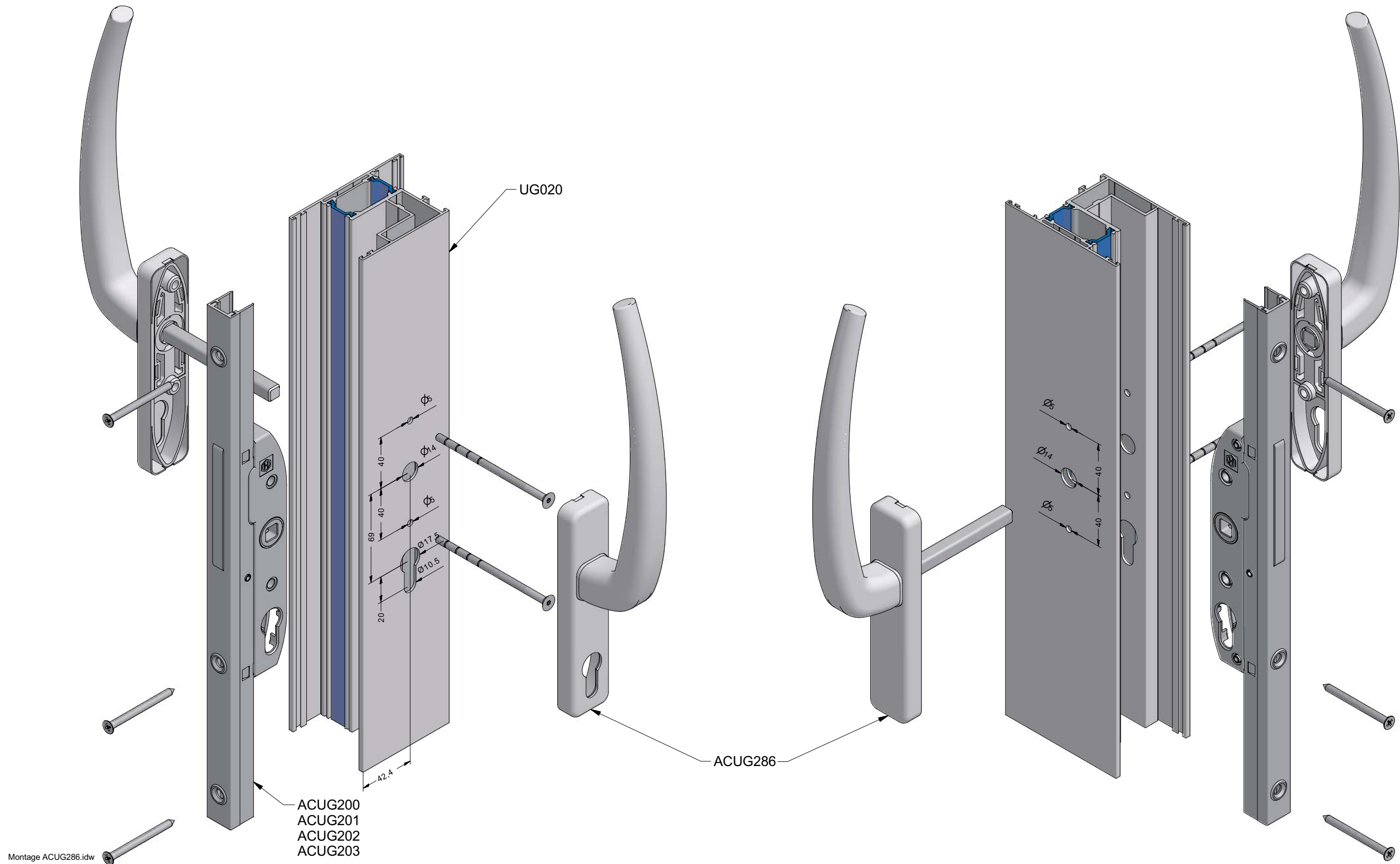

MONTAGE ACUG288
MONTAGE ACUG288
MONTAGE ACUG288
MONTAGE ACUG288

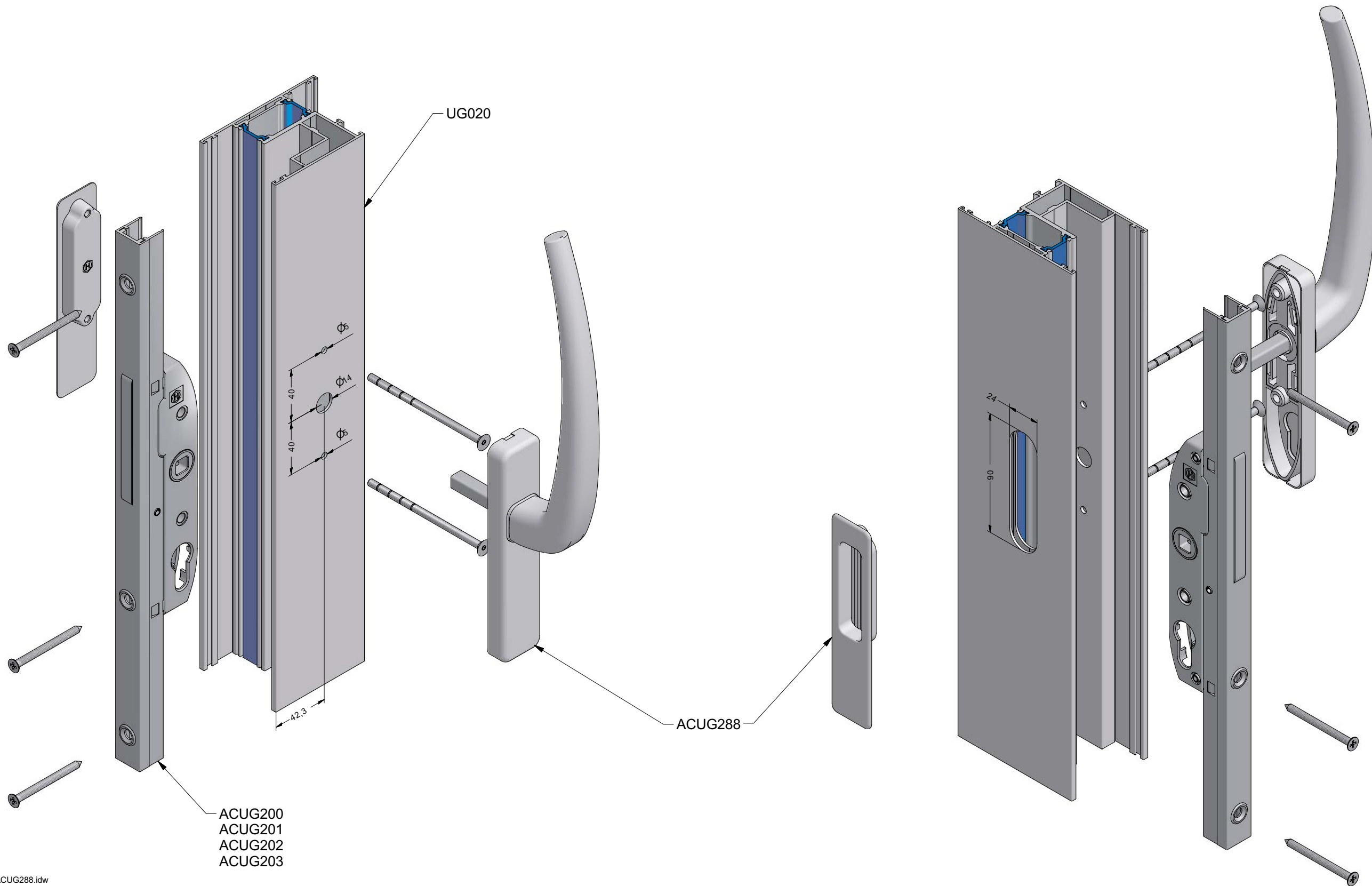

Montage ACUG288.idw

MONTAGE ACUG289
MONTAGE ACUG289
MONTAGE ACUG289
MONTAGE ACUG289

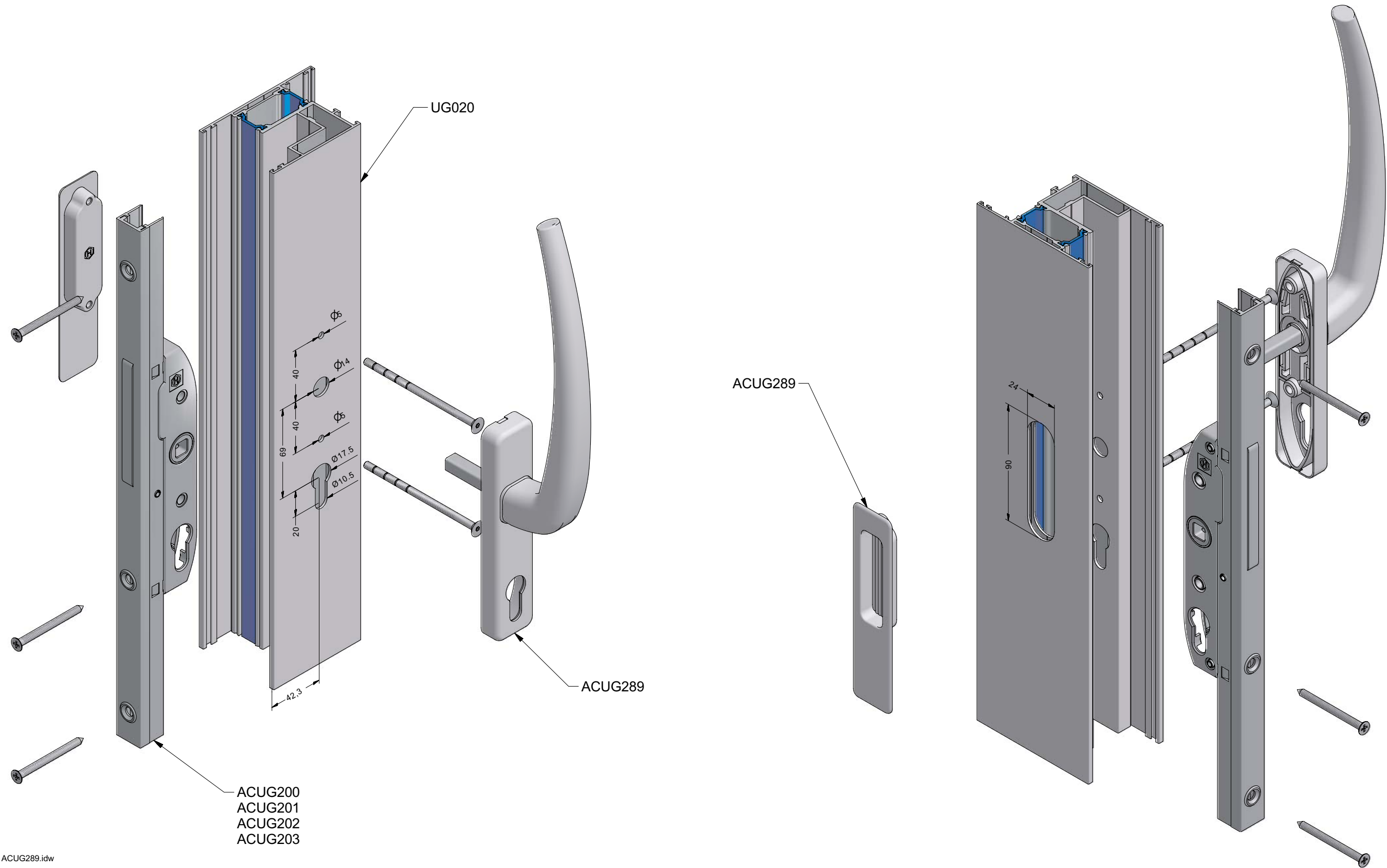

Montage ACUG289.idw

MONTAGE ACUG200 -> ACUG203
 MONTAGE ACUG200 -> ACUG203
 MONTAGE ACUG200 -> ACUG203
 MONTAGE ACUG200 -> ACUG203

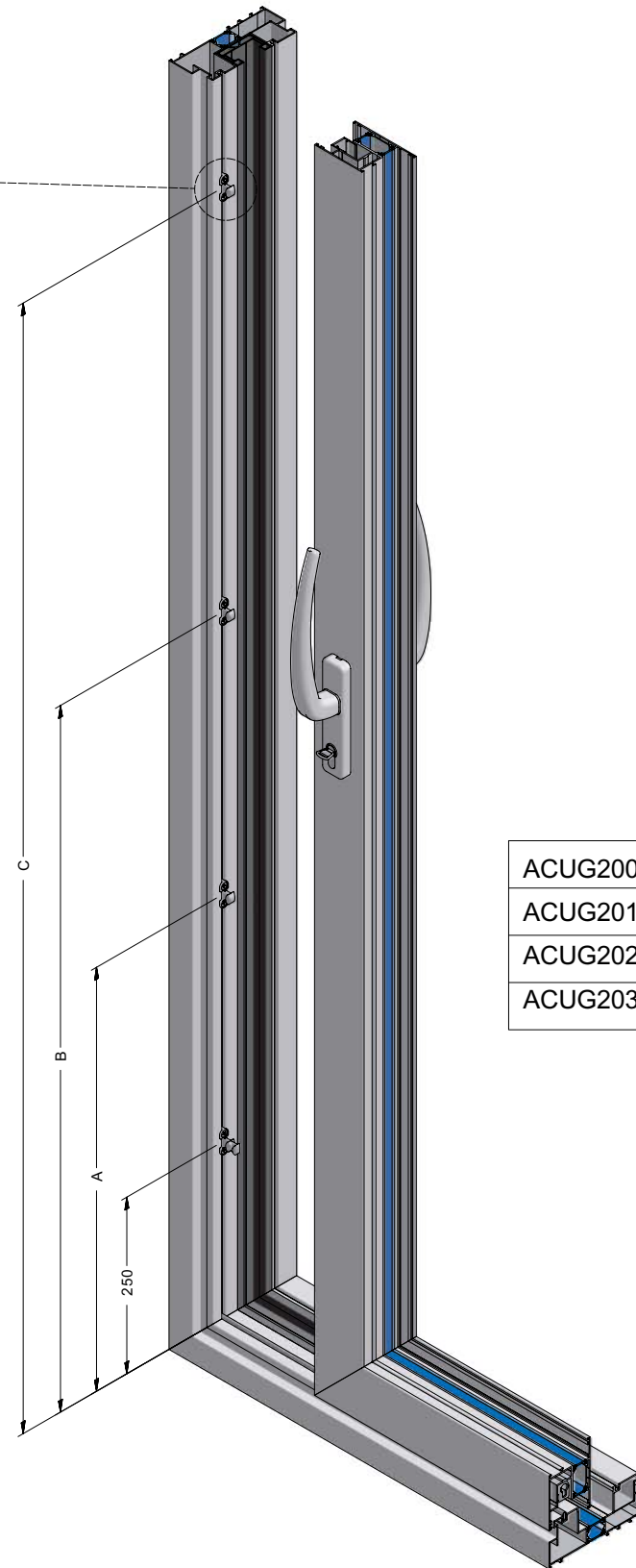
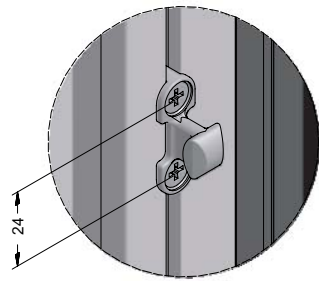
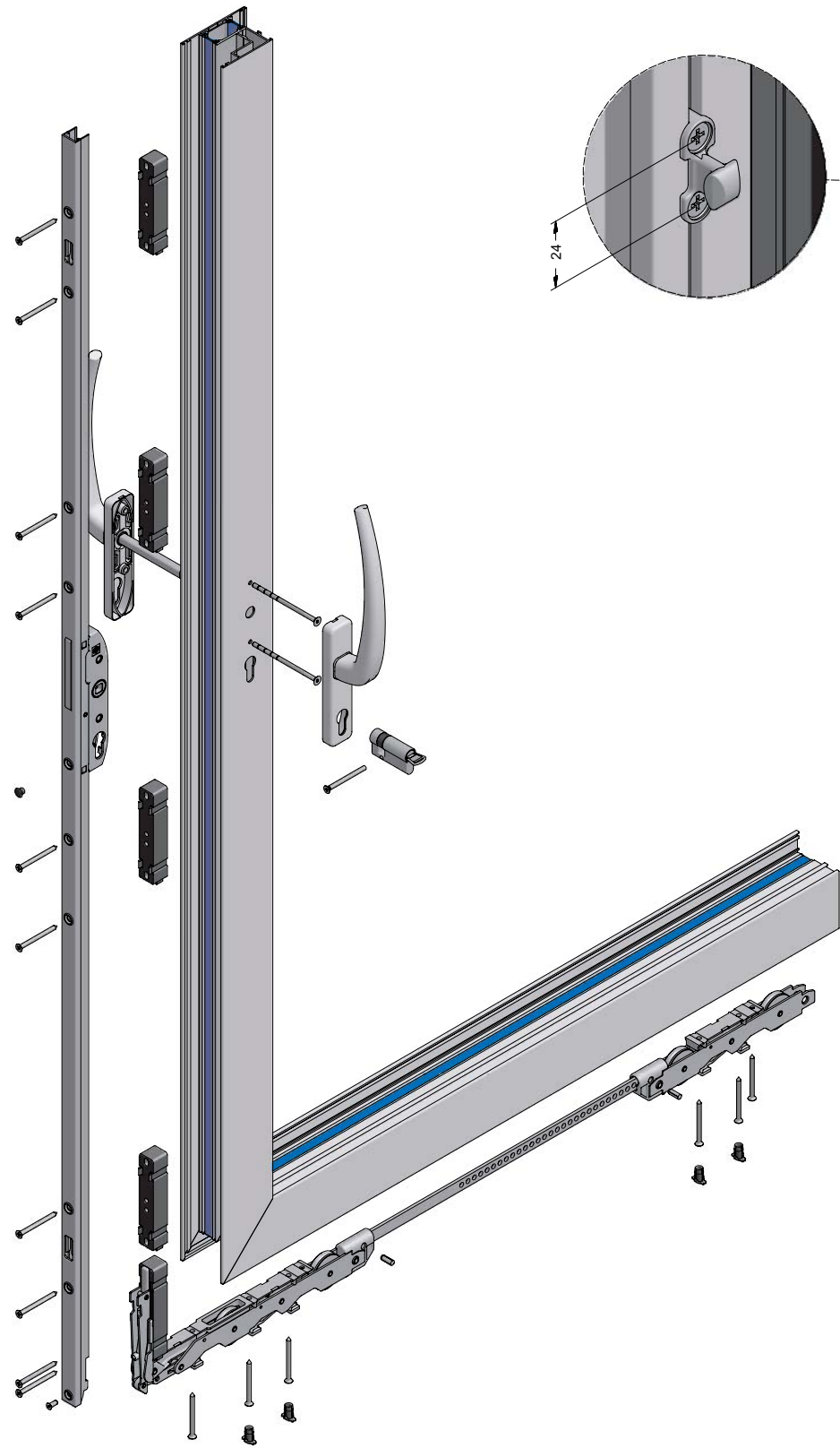

	A (mm)	B(mm)	C (mm)
ACUG200	600	1000	-
ACUG201	750	1200	1600
ACUG202	750	1200	1900
ACUG203	750	1200	2200

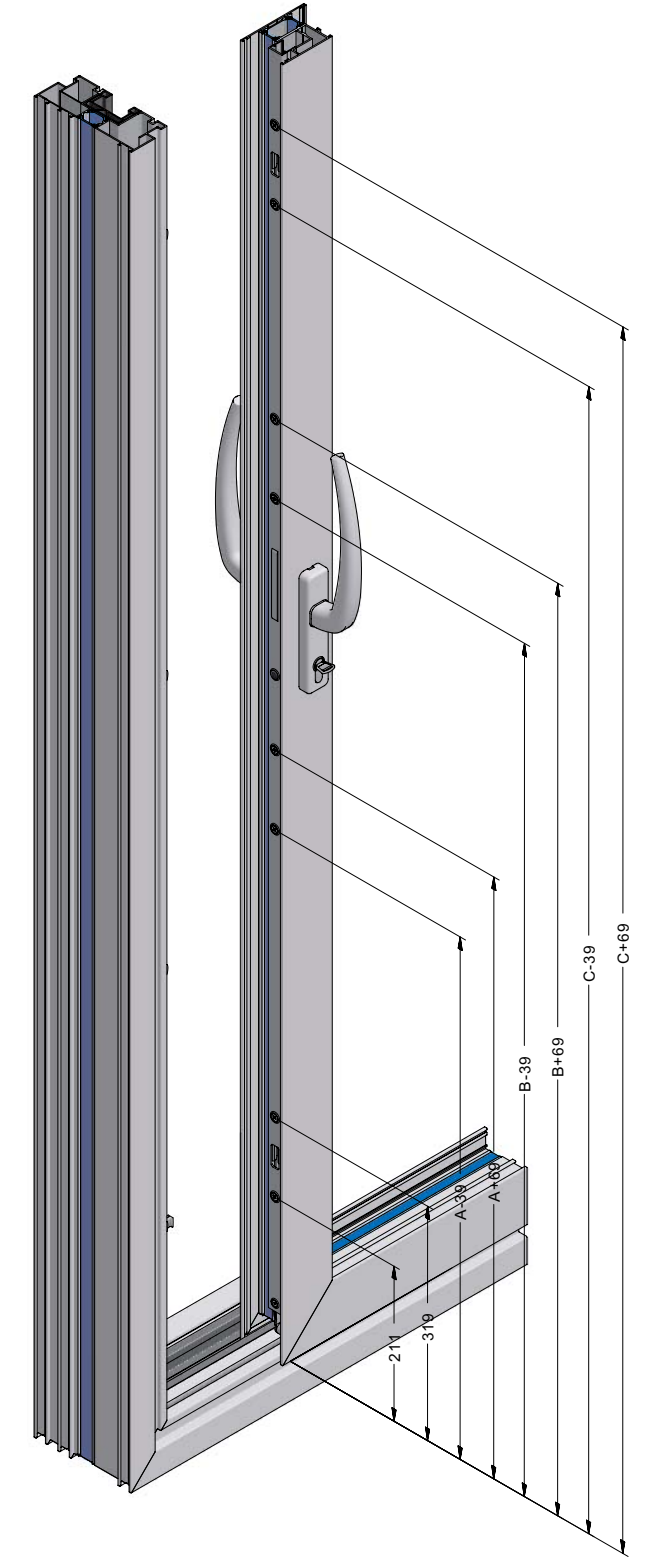

MONTAGE ACUG200 SLOTEN.idw

MONTAGE ACUG210
MONTAGE ACUG210
MONTAGE ACUG210
MONTAGE ACUG210

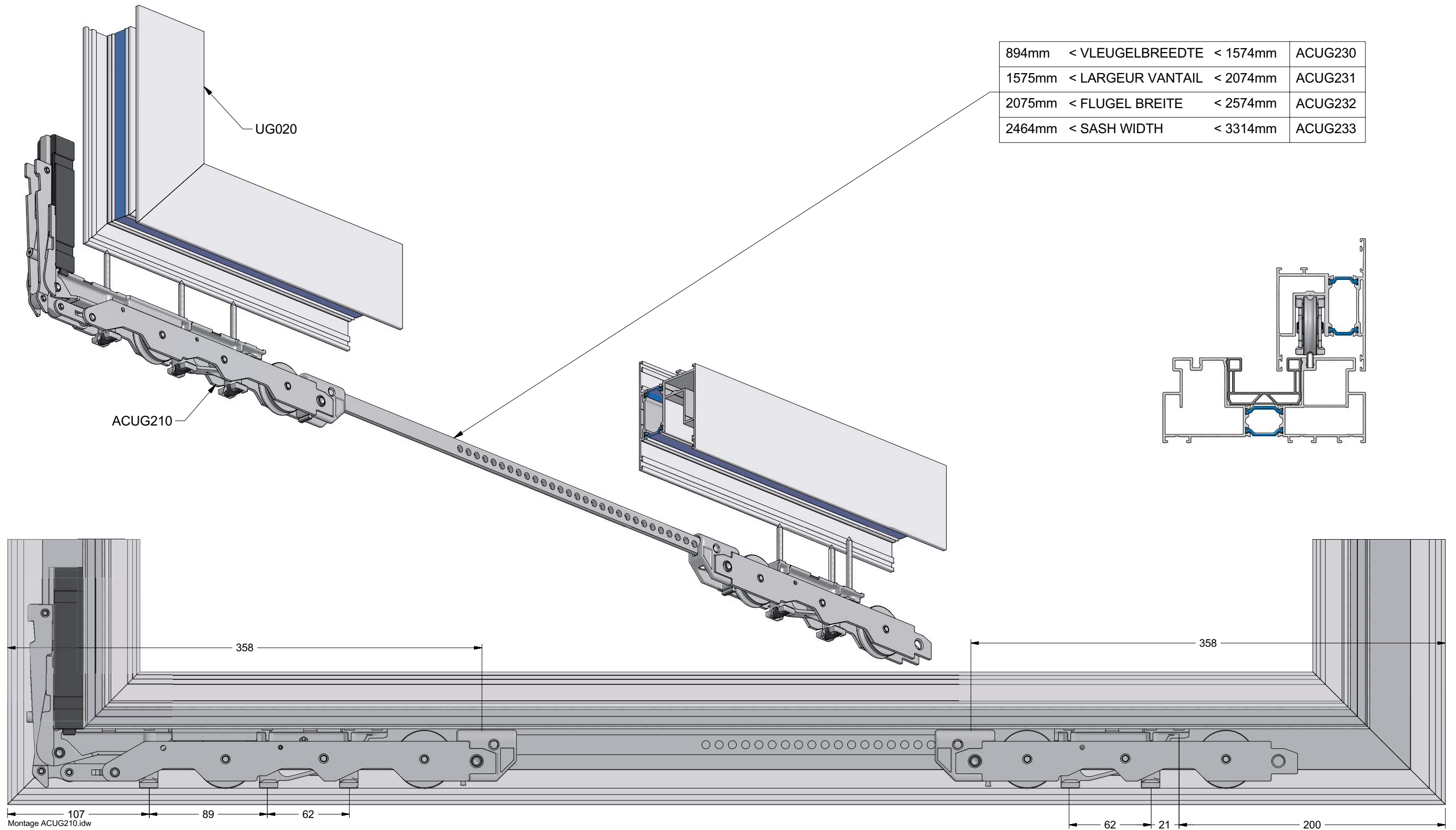

WERKTEKENINGEN - DESSINS DE CONSTRUCTION - KONSTRUKTIONZEICHNUNGEN - CONSTRUCTION DRAWINGS

