

visofold

VOUWDEUREN - 70mm
PORTES AMOVIBLES - 70mm
FALT TUREN - 70mm
FOLDING DOORS - 70mm

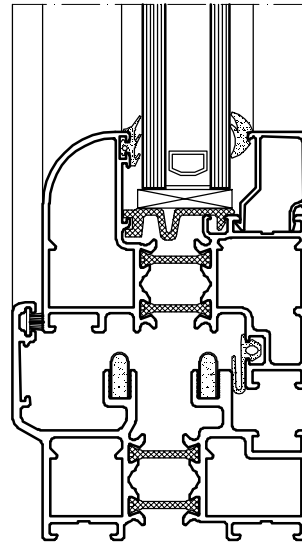

DVa	PROFIELEN _____ P. 11 PROFILS PROFILE PROFILES
DVb	TOEBEHOREN _____ P. 21 ACCESSOIRES ZUBEHORTEILE ACCESSORIES
DVc	DOORSNEDEN _____ P. 45 COUPES SCHNITT SECTIONS
DVd	STATICA _____ P. 101 STATIQUE STATIK STATICS
DVe	ZAAGTABELLEN _____ P. 105 TABLES DE SCIAGES ZUSCHNITT-TABELLEN SAWING TABLES
DVf	WERKTEKENINGEN _____ P. 151 DESSINS DE CONSTRUCTION KONSTRUKTIONZEICHNUNGEN CONSTRUCTION DRAWINGS

AFKORTINGEN / ABBREVIATIONS / ABKURZUNGEN / ABBREVIATIONS

BR = BRUT - BRUT - ROH - BRUT

AN = GEANODISEERD - ANODISE - ELOXIERT - ANODISED

AN (■) = GELAKT - LAQUE - LACKIERT - LACQUERED -- RAL9006M

KL = STANDAARDKLEUREN - COULEURS STANDARDS - BASIS FARBEN - BASIC COLORS

GS = SPECIAAL GEMOFFELD - LAQUE SPECIAL - SPECIALFARBE - SPECIAL COLOR

Z = ZWART - NOIR - SCHWARZ - BLACK

W = WIT - BLANC - WEISS - WHITE

!! OPMERKING - REMARQUE - BEMERKUNG - REMARK !!

Max. 1000mm breedte/ vleugel

Max. 1000mm largeur/ vantail

Max. 1000mm Breite/ Flügel

Max. 1000mm width/ vent

Max. vleugelgewicht 80kg

Poids max. par vantail 80kg

Max. Flügelgewicht 80kg

Max. weight of the vent 80kg

Laatste vleugel opmeten, dan pas zagen

Mesurer le dernier vantail, puis couper

Letzte Flügel abmessen, dann sägen

Measure the last vent, after that saw

De tekeningen die voorgesteld zijn op schaal 1:1, kunnen kleine maatafwijkingen vertonen, te wijten aan de reproductietechniek van deze catalogoog.

Les dessins représentés à l'échelle 1 peuvent avoir de légères variations dimensionnelles dues aux techniques de reproduction de ce catalogue.

Die Zeichnungen im Maßstab 1:1 können aus technischen Reproduktionsgründen leichte Messungsschwankungen darstellen.

The drawings represented on a scale 1 basis may have light dimensional variations due to the reproduction of the manual.

BUITENKADERS	P. 11
PROFILS D'ENCADREMENT KADERPROFILE OUTER FRAMES	
VLEUGELPROFIELEN	P. 14
OUVRANTS FLUGELPROFILE VENT PROFILES	
GLASLATTEN	P. 16
LATTES A VITRAGE GLASLEISTE GLAZING BEADS	
DORPELPROFIELEN	P. 18
SEUILS SOLLPROFILE SILL MEMBERS	
DIVERSE PROFIELEN	P. 19
DIVERS PROFILS DIVERS PROFILE VARIED PROFILES	

VOUWDEUR NAAR BINNEN OPENEND _____ P. 45
PORTES AMOVIBLES OUVRANT INTERIEUR
FALT TUREN NACH INNEN OFFNEND
FOLDING DOORS INWARDS OPENING

VOUWDEUR NAAR BUITEN OPENEND _____ P. 69
PORTES AMOVIBLES OUVRANT EXTERIEUR
FALT TUREN NACH AUSSEN OFFNEND
FOLDING DOORS OUTWARDS OPENING

RAMEN _____ P. 89
FENETRES
RAHMEN
WINDOWS

GLASTABELLEN _____ P. 100
TABLES DE VITRAGE
BEGLAZUNG TABELLEN
GLAZING TABLES

GEWONE DORPEL, STANGENSLUITING, BINNENDRAAIEND _____ P. 105
SEUIL, SERRURE A TRINGLE, OUVRANT INTERIEUR
SCHWELLE, TREIBRIEGELSCHLOSS, INNEN OFFNEND
THRESHOLD, EXTENDED BOLT LOCK, INWARDS OPENING

GEWONE DORPEL, CILINDERSLOT, BINNENDRAAIEND _____ P. 115
SEUIL, SERRURE A CYLINDRE, OUVRANT INTERIEUR
SCHWELLE, ZYLINDERSCHLOSS, INNEN OFFNEND
THRESHOLD, SECURITY LOCK, INWARDS OPENING

GEWONE DORPEL, STANGENSLUITING, BUITENDRAAIEND _____ P. 120
SEUIL, SERRURE A TRINGLE, OUVRANT EXTERIEUR
SCHWELLE, TREIBRIEGELSCHLOSS, AUSSEN OFFNEND
THRESHOLD, EXTENDED BOLT LOCK, OUTWARDS OPENING

GEWONE DORPEL, CILINDERSLOT, BUITENDRAAIEND _____ P. 127
SEUIL, SERRURE A CYLINDRE, OUVRANT EXTERIEUR
SCHWELLE, ZYLINDERSCHLOSS, AUSSEN OFFNEND
THRESHOLD, SECURITY LOCK, OUTWARDS OPENING



VLAKKE DORPEL, STANGENSLUITING, BINNENDRAAIEND _____ P. 133
SEUIL PLAT, SERRURE A TRINGLE, OUVRANT INTERIEUR
FLACHE SCHWELLE, TREIBRIEGELSCHLOSS, INNEN OFFNEND
FLAT THRESHOLD, EXTENDED BOLT LOCK, INWARDS OPENING

VLAKKE DORPEL, CILINDERSLOT, BINNENDRAAIEND _____ P. 136
SEUIL PLAT, SERRURE A CYLINDRE, OUVRANT INTERIEUR
FLACHE SCHWELLE, ZYLINDERSCHLOSS, INNEN OFFNEND
FLAT THRESHOLD, SECURITY LOCK, INWARDS OPENING

VLAKKE DORPEL, STANGENSLUITING, BUITENDRAAIEND _____ P. 142
SEUIL PLAT, SERRURE A TRINGLE, OUVRANT EXTERIEUR
FLACHE SCHWELLE, TREIBRIEGELSCHLOSS, AUSSEN OFFNEND
FLAT THRESHOLD, EXTENDED BOLT LOCK, OUTWARDS OPENING

VLAKKE DORPEL, CILINDERSLOT, BUITENDRAAIEND _____ P. 144
SEUIL PLAT, SERRURE A CYLINDRE, OUVRANT EXTERIEUR
FLACHE SCHWELLE, ZYLINDERSCHLOSS, AUSSEN OFFNEND
FLAT THRESHOLD, SECURITY LOCK, OUTWARDS OPENING

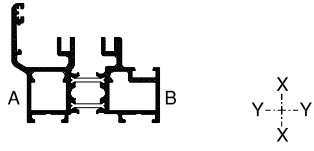
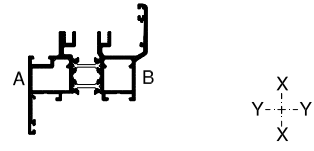
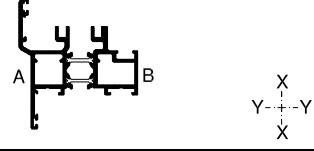
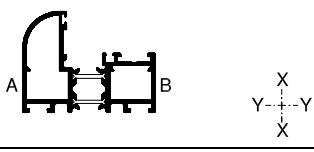
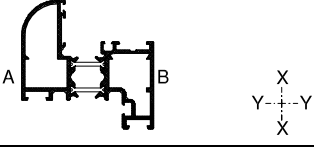
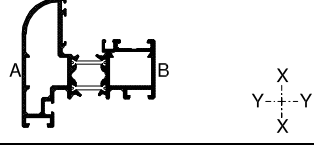
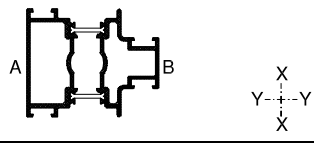
OPSPIEEN VAN HET GLAS _____	P. 151
CALLAGE DU VITRAGE VERKLOTZUNGS HINWEIZE CALIBRATION OF THE GLASS	
MONTAGE EN UITSPARING VOOR LOOPWAGEN EN GLIJBLOK _____	P. 152
MONTAGE ET ENTAILLES POUR ROULETTE ET BLOCK DE GUIDAGE MONTAGE UND AUSSPARUNGEN FUR LAUFWERK UND FUHRUNGSSTUCK MONTAGE AND MACHINING FOR ROLLING BLOCK AND SLIDING BLOCK	
SLOTEN EN UITSPARINGEN _____	P. 162
SERRURES ET ENTAILLES SCHLOSSER UND EINBAU LOCKS AND EMBEDDING	
HOEKEN _____	P. 173
CLAMES ECKVERBINDERS CORNERS	
ONTWATERING _____	P. 175
DRAINAGE ENTWASSERUNG DRAINING	
DIVERSE TEKENINGEN _____	P. 177
DIVERS DESSINS DIVERS ZEICHNUNGEN VARIED DRAWINGS	

NUMMER NUMERO NUMBER	AFBEELDING IMAGE BILD PICTURE	BLAD PAGE SEITE PAGE	OMTREK PERIM. UMRIB PERIM. mm	MECH. MEC. MECH. MEC. mm	Ix (cm4)		LENGTE LONG. LANGE LENGTH	VERP. PER EMB. PAR PACK PR.	BR	AN	KL	GS	M1
					Wy (cm3)	Wy (cm3)							
DV10		11	523.4	158	41.34	16.23	3.25 6.5	2	X	X	X	X	X
					10.05	4.20							
DV12		11	586.5	128	48.57	22.2	6.5	2	X	X	X	X	X
					12.32	5.04							
DV13		12	586.1	128	44.83	22.24	6.5	2	X	X	X	X	X
					10.44	5.04							
DV18		12	380.8	98	27.03	11.17	6.5	2	X	X	X	X	X
					7.21	3.36							
DV20		14	428.1	112	32.22	16.35	6.5	2	X	X	X	X	X
					9.04	4.45							
DV21		14	429	117	30.59	16.33	6.5	2	X	X	X	X	X
					7.61	4.44							
DV31		19	367	85	31.31	18.19	5	2	X	X	X	X	X
					8.38	6.38							
DV52		19	131.9	32	-	-	6.5	6	X	X	X	X	
DV53		19	56.9	-	-	-	6.5	6	X				

BR = BRUT - BRUT - ROH - BRUT

AN = ANODISATIE - ANODISE - ELOXIERT - ANODISED

KL = STANDAARDKLEUREN - COULEUR STANDARD - BASIS FARBEN - BASIC COLORS

GS = GEMOFFELD SPECIAAL - LAQUE SPECIAL - SPECIALFARBE - SPECIAL COLOR

M1 = BICOLOR - BICOLOR - BICOLOR - BICOLOR

A = BUITEN - EXTERIEUR - AUSSEN - OUTSIDE

B = BINNEN - INTERIEUR - INNEN - INSIDE

NUMMER NUMERO NUMBER	AFBEELDING IMAGE BILD PICTURE	BLAD PAGE SEITE PAGE	OMTREK PERIM. UMRIB PERIM. mm	MECH. MEC. MECH. MEC. mm	Ix (cm4)	Iy (cm4)	LENGTE LONG. LANGE LENGTH	VERP. PER EMB. PAR PACK PR.	BR	AN	KL	GS	M1
					Wx (cm3)	Wy (cm3)							
DV56		19	124.9	-	-	-	5	6	X	X	X	X	
DV70		18	348	111	27.86 7.81	4.38 2.76	3.25 6.5	2	X	X	X	X	
DV120		15	437.1	129.6	34.02 9.67	18.25 5.08	6.5	2	X	X	X	X	X
DV170		18	364.3	217.5	29.32 8.24	6.64 3.88	6.5	2	X	X	X	X	X
DV313		13	634.4	137	53.09 11.47	29.41 6.77	6.5		X	X	X	X	X
VG52		19	-	-	-	-	6.5	-	X				
VG53		19	-	-	-	-	6.5	-	X				
VG53A		19	-	-	-	-	6.5	-	X				
VL61		16	92.1	29	-	-	6.5	10	X	X	X	X	

BR = BRUT - BRUT - ROH - BRUT
AN = ANODISATIE - ANODISE - ELOXIERT - ANODISED
KL = STANDAARDKLEUREN - COULEUR STANDARD - BASIS FARBEN - BASIC COLORS
GS = GEMOFFELD SPECIAAL - LAQUE SPECIAL - SPECIALFARBE - SPECIAL COLOR
M1 = BICOLOR - BICOLOR - BICOLOR - BICOLOR

NUMMER NUMERO NUMBER NUMBER	AFBEELDING IMAGE BILD PICTURE	BLAD PAGE SEITE PAGE	OMTREK PERIM. UMRIB PERIM. mm	MECH. MEC. MEC. MEC. mm	lx (cm4)		LENGTE LONG. LANGE LENGTH	VERP. PER EMB. PAR PACK PR. PACK PR.	BR	AN	KL	GS	M1
					Wx (cm3)	Wy (cm3)							
VL62		16	146.6	40	-	-	6,5	10	X	X	X	X	
VL63		17	152.7	44	-	-	6,5	10	X	X	X	X	
VL64		17	169.2	50	-	-	6,5	6	X	X	X	X	
VL65		17	195.8	59	-	-	6,5	6	X	X	X	X	
VL66		16	140.1	40	-	-	6,5	10	X	X	X	X	
VL610		16	109.4	30	-	-	6.5	10	X	X	X	X	
VL611		16	117.4	34	-	-	6.5	10	X	X	X	X	
VL640		17	187.8	52	-	-	6.5	6	X	X	X	X	

BUITENKADERS
PROFILS D'ENCADREMENT
KADERPROFILE
OUTER FRAMES

PROFIELEN - PROFILS- PROFILE - PROFILES

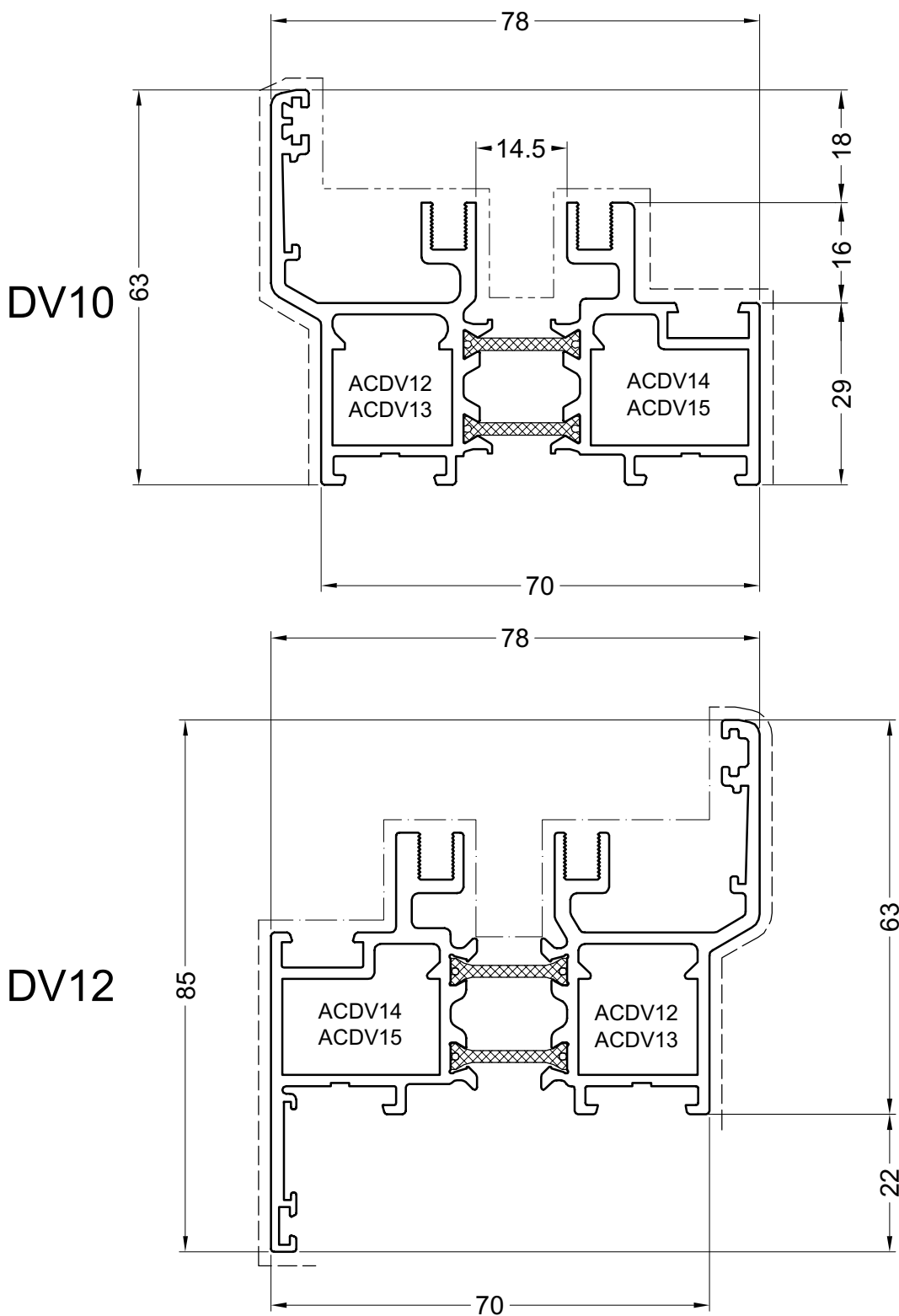

PAG_A3

Primaire zichtbare zijde
Face visible primaire
Primär sichtbare Seite
Primary visible side

Secundaire zichtbare zijde
Face visible secondaire
Secondär sichtbare Seite
Secondary visible side

BUITENKADERS
PROFILS D'ENCADREMENT
KADERPROFILE
OUTER FRAMES

PROFIELEN - PROFILS - PROFILE - PROFILES

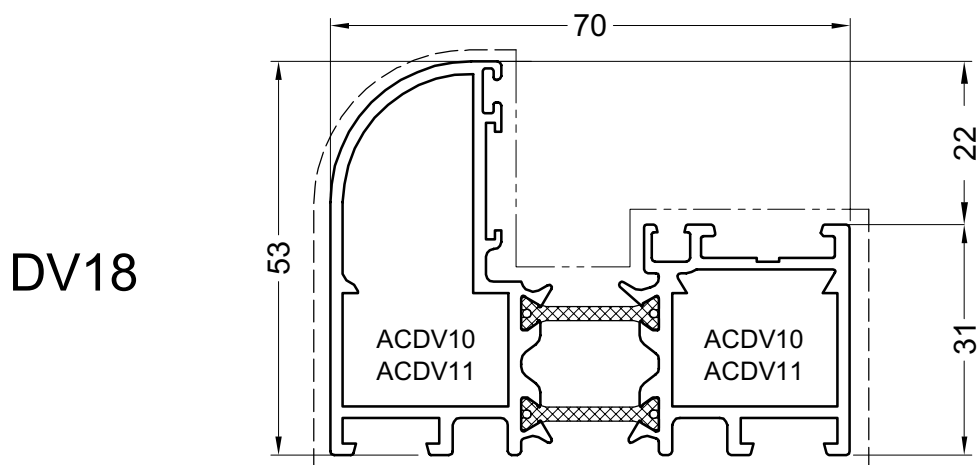
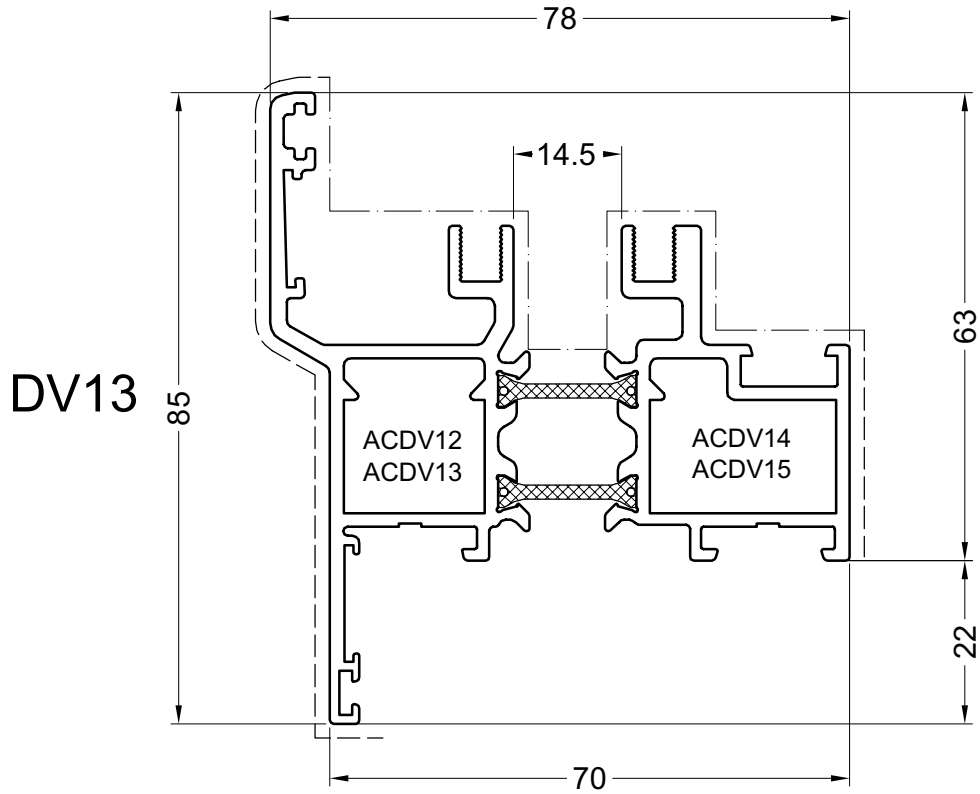

PAG_A8

Primaire zichtbare zijde
Face visible primaire
Primär sichtbare Seite
Primary visible side

Secundaire zichtbare zijde
Face visible secondaire
Secondär sichtbare Seite
Secondary visible side

BUITENKADERS
PROFILS D'ENCADREMENT
KADERPROFILE
OUTER FRAMES

PROFIELEN - PROFILS- PROFILE - PROFILES

DV313

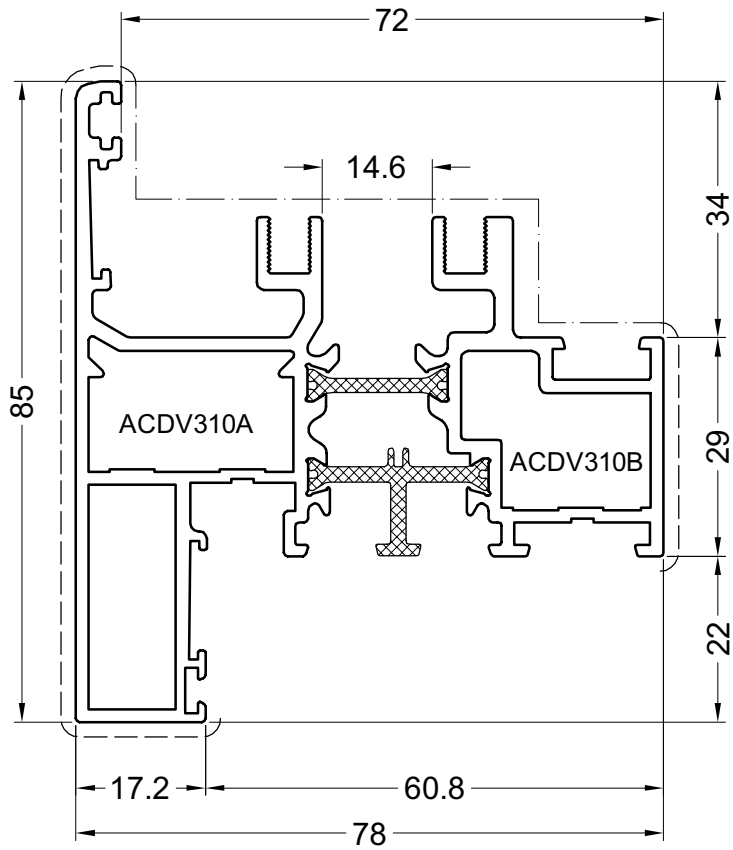

PAG_A10

Primaire zichtbare zijde
Face visible primaire
Primär sichtbare Seite
Primary visible side

Secundaire zichtbare zijde
Face visible secondaire
Secondär sichtbare Seite
Secondary visible side

14/6/06

DV20

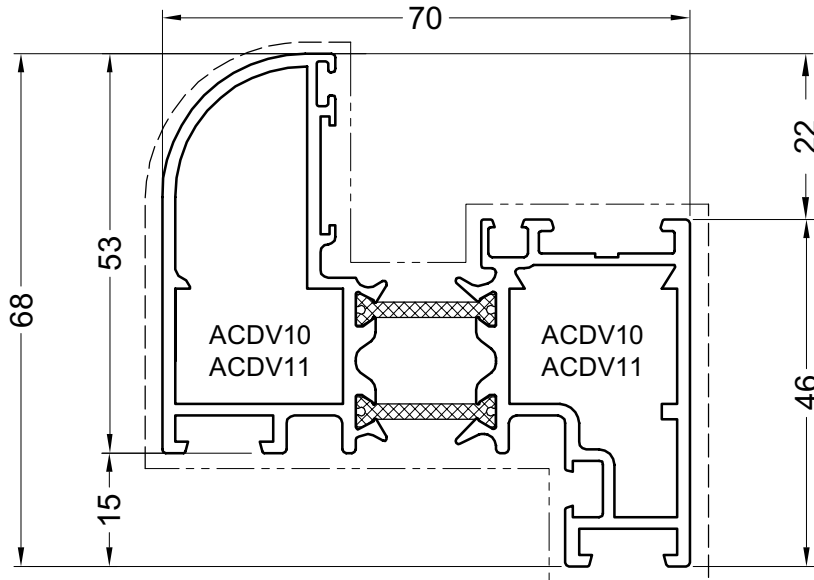

DV21

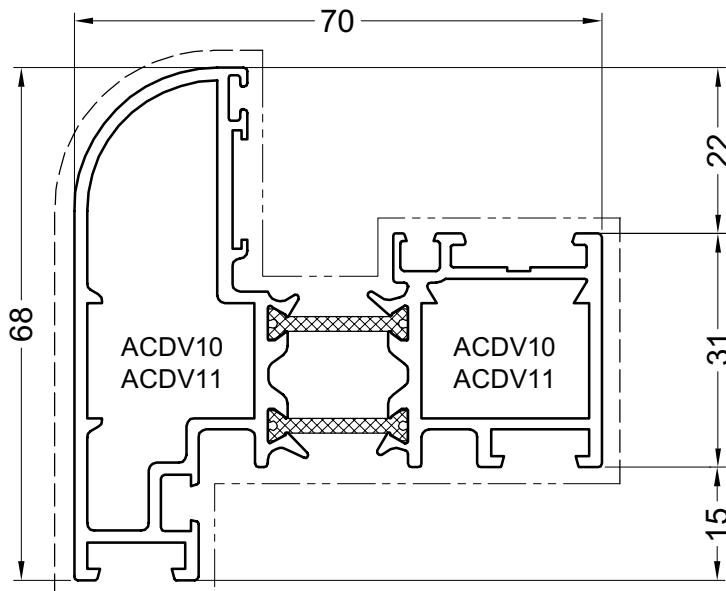

DV120

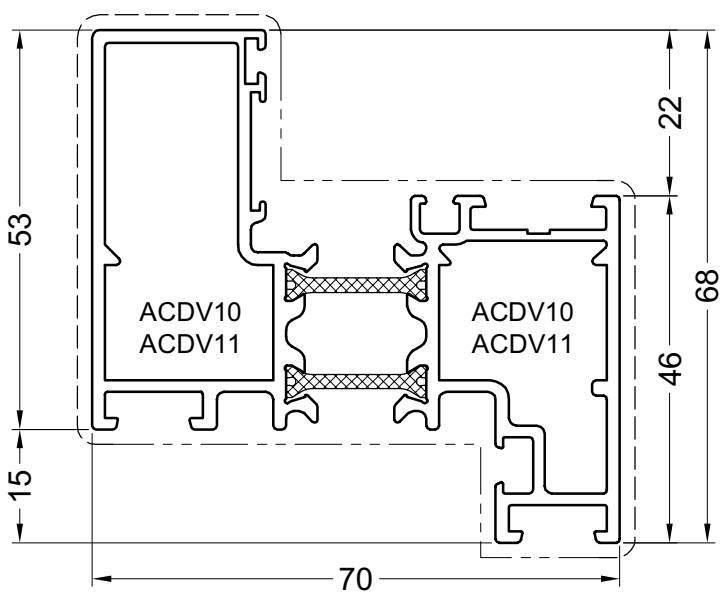

PAG_A9

Primaire zichtbare zijde
Face visible primaire
Primär sichtbare Seite
Primary visible side

Secundaire zichtbare zijde
Face visible secondaire
Secondär sichtbare Seite
Secondary visible side

GLASLATTEN
LATTES A VITRAGE
GLASLEISTE
GLAZING BEADS

PROFIELEN - PROFILS- PROFILE - PROFILES

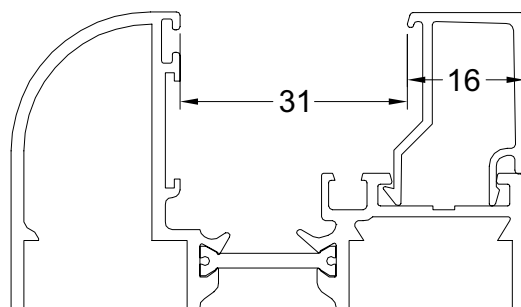
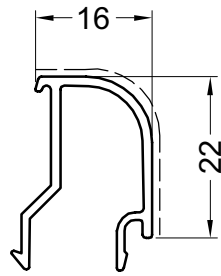
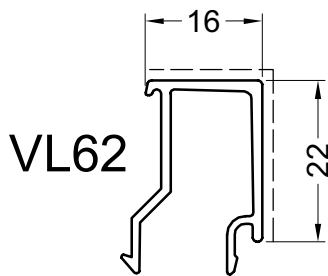
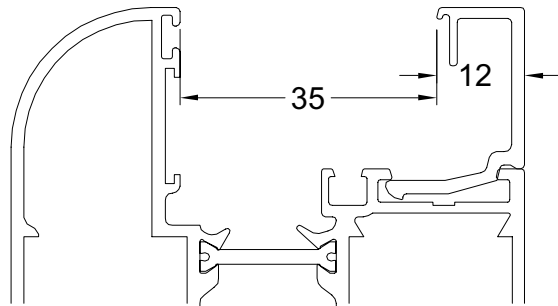
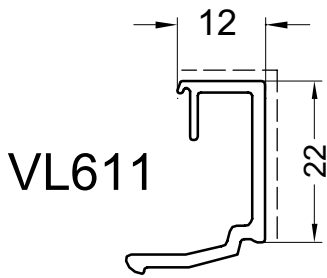
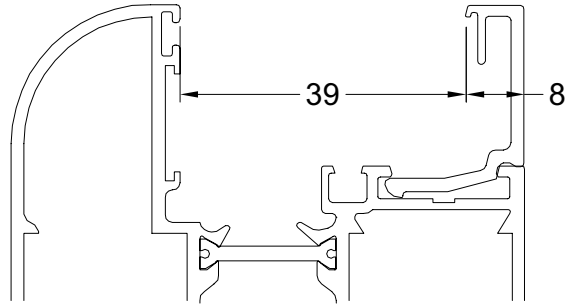
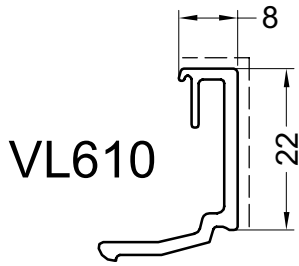
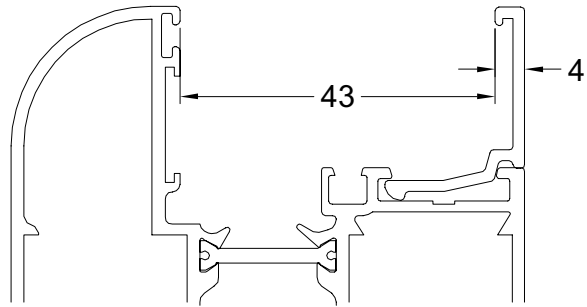
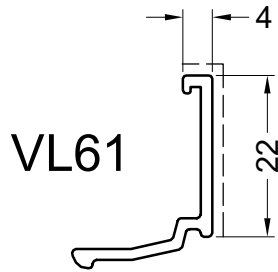

PAG_A6

GLASLATTEN
LATTES A VITRAGE
GLASLEISTE
GLAZING BEADS

PROFIELEN - PROFILS- PROFILE - PROFILES

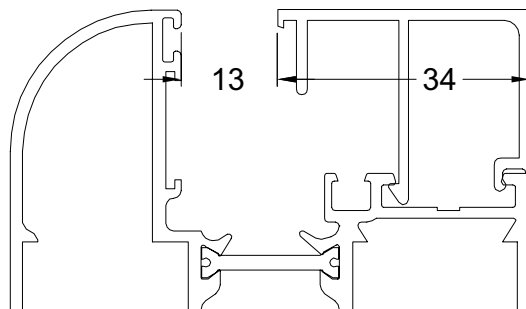
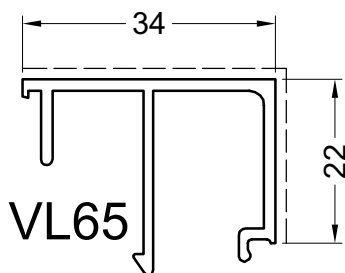
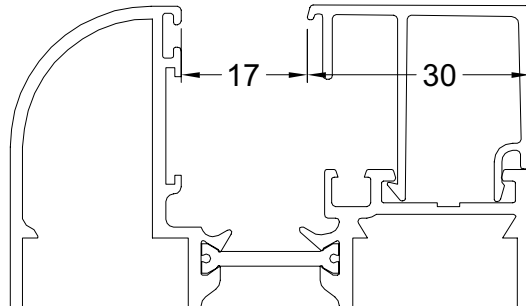
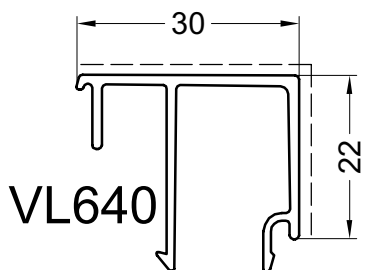
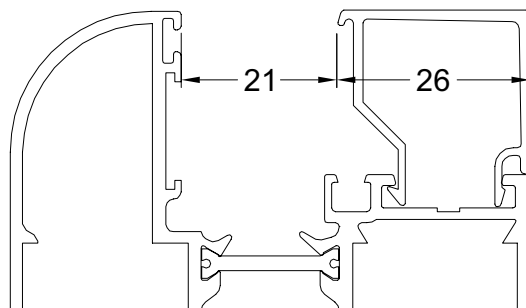
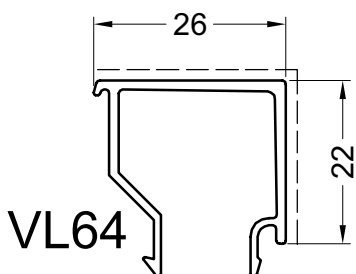
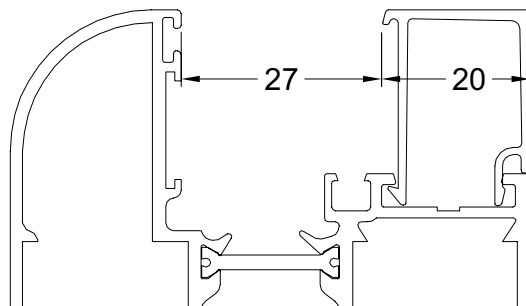
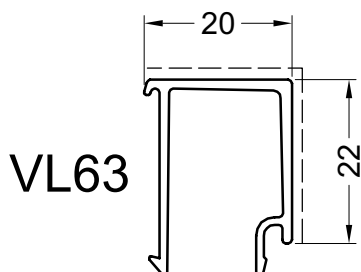

PAG_A7

Primaire zichtbare zijde
Face visible primaire
Primär sichtbare Seite
Primary visible side

Secundaire zichtbare zijde
Face visible secondaire
Secondär sichtbare Seite
Secondary visible side

DORPELPROFIELEN
SEUILS
SOLLPROFILE
SILL MEMBERS

PROFIELEN - PROFILS- PROFILE - PROFILES

DV70

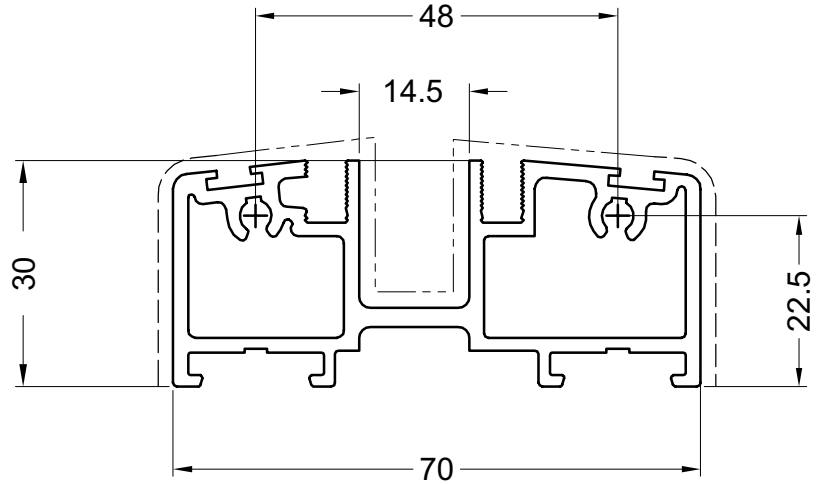

DV170

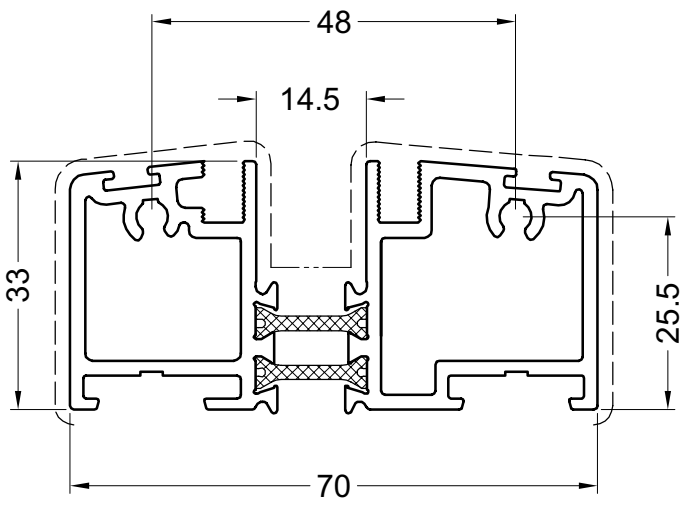

PAG_A2

Primaire zichtbare zijde
Face visible primaire
Primär sichtbare Seite
Primary visible side

Secundaire zichtbare zijde
Face visible secondaire
Secondär sichtbare Seite
Secondary visible side

DIVERSE PROFIELEN
PROFILS DIVERS
DIVERS PROFILE
VARIED PROFILES

PROFIELEN - PROFILS- PROFILE - PROFILES

DV31

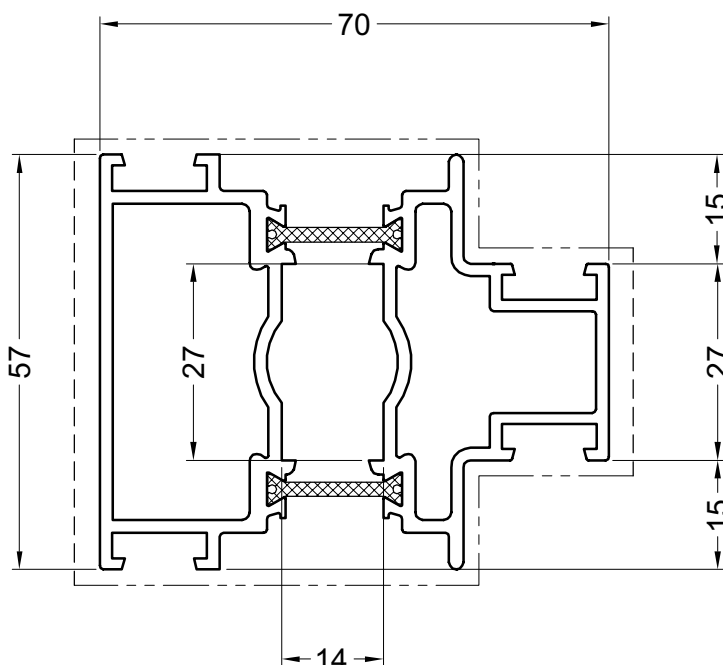

DV52

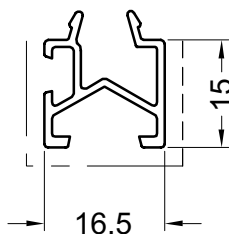

VG53

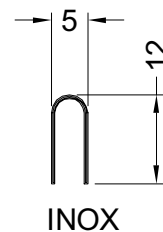

DV53

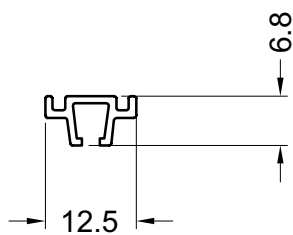

VG53A

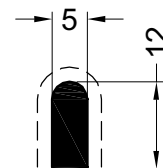

DV56

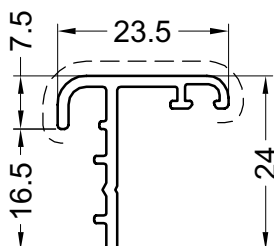



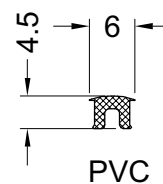



VG52



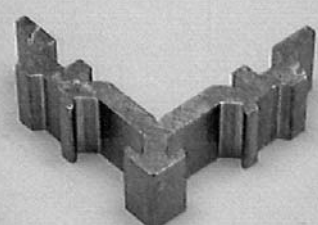

PAG_A5

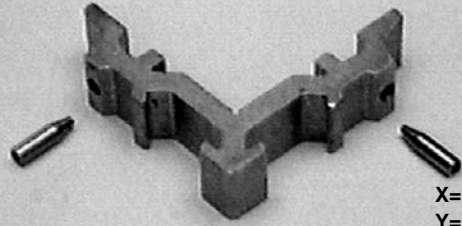
Primaire zichtbare zijde
Face visible primaire
Primär sichtbare Seite
Primary visible side

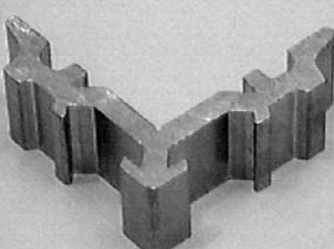

Secundaire zichtbare zijde
Face visible secondaire
Secondär sichtbare Seite
Secondary visible side

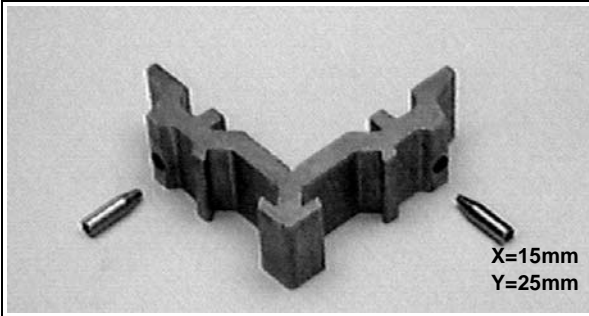
	Verp. per Emb. par Pack pr.	Einheid Unité Einheit Unit	Toepassing Application Anwendung Application	Kleur Couleur Farbe Color												
 <p>ACDV10 -Pershoek -Clame à presser pour chambre extérieure -Eckverbinder Stanzbar für aussere kammer -Clamping corner for outside chamber</p> <p>X=15mm Y=22mm</p>	1 24	Stuk Pièce Stück Pièce	DV20 DV21 DV18	<table border="1"> <tr><td>BR</td><td></td></tr> <tr><td>AN</td><td></td></tr> <tr><td>KL</td><td></td></tr> <tr><td>GS</td><td></td></tr> <tr><td>Z</td><td></td></tr> <tr><td>W</td><td></td></tr> </table>	BR		AN		KL		GS		Z		W	
BR																
AN																
KL																
GS																
Z																
W																
 <p>ACDV11 -Stifthoek -Clame à goupiller -Eckverbinder verstifted -Square bracket</p> <p>X=15mm Y=22mm</p> <p> ACDV235</p>	1 24	Stuk Pièce Stück Pièce	DV20 DV21 DV18	<table border="1"> <tr><td>BR</td><td></td></tr> <tr><td>AN</td><td></td></tr> <tr><td>KL</td><td></td></tr> <tr><td>GS</td><td></td></tr> <tr><td>Z</td><td></td></tr> <tr><td>W</td><td></td></tr> </table>	BR		AN		KL		GS		Z		W	
BR																
AN																
KL																
GS																
Z																
W																
 <p>ACDV12 -Pershoek voor buitenste kamer -Clame à presser pour chambre extérieure -Eckverbinder verstifted für aussere kammer -Square bracket for outside chamber</p> <p>X=15mm Y=18mm</p>	1 24	Stuk Pièce Stück Pièce	DV10	<table border="1"> <tr><td>BR</td><td></td></tr> <tr><td>AN</td><td></td></tr> <tr><td>KL</td><td></td></tr> <tr><td>GS</td><td></td></tr> <tr><td>Z</td><td></td></tr> <tr><td>W</td><td></td></tr> </table>	BR		AN		KL		GS		Z		W	
BR																
AN																
KL																
GS																
Z																
W																
 <p>ACDV13 -Stifthoek voor buitenste kamer -Clame à goupiller pour chambre extérieure -Eckverbinder verstifted für aussere kammer -Square bracket for outside chamber</p> <p>X=15mm Y=18mm</p> <p> ACDV235</p>	1 24	Stuk Pièce Stück Pièce	DV10	<table border="1"> <tr><td>BR</td><td></td></tr> <tr><td>AN</td><td></td></tr> <tr><td>KL</td><td></td></tr> <tr><td>GS</td><td></td></tr> <tr><td>Z</td><td></td></tr> <tr><td>W</td><td></td></tr> </table>	BR		AN		KL		GS		Z		W	
BR																
AN																
KL																
GS																
Z																
W																
 <p>ACDV14 -Pershoek voor binnenste kamer -Clame à presser pour chambre intérieure -Eckverbinder Stanzbar für innere kammer -Clamping corner for inside chamber</p> <p>X=15mm Y=25mm</p>	1 24	Stuk Pièce Stück Pièce	DV10	<table border="1"> <tr><td>BR</td><td></td></tr> <tr><td>AN</td><td></td></tr> <tr><td>KL</td><td></td></tr> <tr><td>GS</td><td></td></tr> <tr><td>Z</td><td></td></tr> <tr><td>W</td><td></td></tr> </table>	BR		AN		KL		GS		Z		W	
BR																
AN																
KL																
GS																
Z																
W																

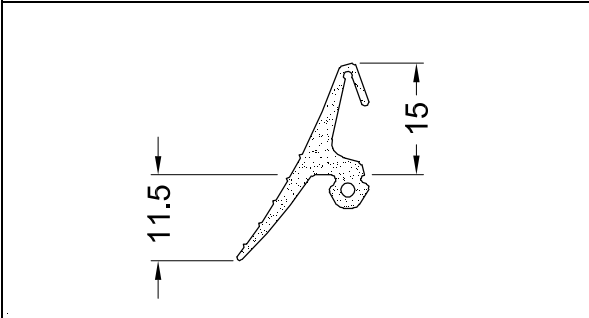

		Verp. per Emb. par Pack pr. Pack pr.	Eenheid Unité Einheit Unit	Toepassing Application Anwendung Application	Kleur Couleur Farbe Color												
 <p>ACDV15 -Stifthoek voor binnenste kamer -Clame à goupiller pour chambre intérieure -Eckverbinder verstiftet für innere kammer -Square bracket for inside chamber</p> <p> ACDV235</p> <p>X=15mm Y=25mm</p>		1 24	Stuk Pièce Stück Piece		<table border="1"> <tr><td>BR</td><td></td></tr> <tr><td>AN</td><td></td></tr> <tr><td>KL</td><td></td></tr> <tr><td>GS</td><td></td></tr> <tr><td>Z</td><td></td></tr> <tr><td>W</td><td></td></tr> </table>	BR		AN		KL		GS		Z		W	
BR																	
AN																	
KL																	
GS																	
Z																	
W																	
 <p>ACDV30 -Middendichting DV -Joint central DV -Mitteldichtung DV -Central gasket DV</p>		100	m		<table border="1"> <tr><td>BR</td><td></td></tr> <tr><td>AN</td><td></td></tr> <tr><td>KL</td><td></td></tr> <tr><td>GS</td><td></td></tr> <tr><td>Z</td><td></td></tr> <tr><td>W</td><td></td></tr> </table>	BR		AN		KL		GS		Z		W	
BR																	
AN																	
KL																	
GS																	
Z																	
W																	

BR = BRUT - BRUT - ROH - BRUT
 AN (X) = ANODISATIE - ANODISE - ELOXIERT - ANODISED
 AN (■) = GELAKT - LAQUE - LACKIERT - LACQUERED -- RAL9006M
 KL = STANDAARDKLEUREN - COULEUR STANDARD - BASIS FARBEN - BASIC COLORS
 GS = GEMOFFELD SPECIAAL - LAQUE SPECIAL - SPECIALFARBE - SPECIAL COLOR
 Z = ZWART - NOIR - SCHWARZ - BLACK
 W = WIT - BLANC - WEISS - WHITE

 GEREEDSCHAP - OUTILLAGE
 WERKZEUG - TOOL
 BEVESTIGING - FIXATION
 BEFESTIGUNG - FIXATION



	Verp. per Emb. par Pack pr.	Einheid Unité Einheit Unit	Toepassing Application Anwendung Application	Kleur Couleur Farbe Color
	1	Stuk Pièce Stück Piece	ACDV220	BR
				AN
				KL
				GS
				Z
				W

ACDV116

- Driepuntsslot met rol zonder kruk
- Serrure 3 points avec rouleau sans poignée
- 3 Punkt schloss mit rolle ohne griff
- Lock with 3 points without handle

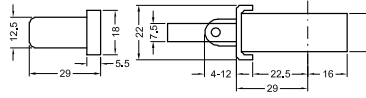

BR = BRUT - BRUT - ROH - BRUT
 AN (X) = ANODISATIE - ANODISE - ELOXIERT - ANODISED
 AN (■) = GELAKT - LAQUE - LACKIERT - LACQUERED -- RAL9006M
 KL = STANDAARDKLEUREN - COULEUR STANDARD - BASIS FARBEN - BASIC COLORS
 GS = GEMOFFELD SPECIAAL - LAQUE SPECIAL - SPECIALFARBE - SPECIAL COLOR
 Z = ZWART - NOIR - SCHWARZ - BLACK
 W = WIT - BLANC - WEISS - WHITE



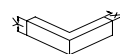

GEREEDSCHAP - OUTILLAGE
WERKZEUG - TOOL

BEVESTIGING - FIXATION
BEFESTIGUNG - FIXATION

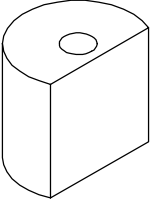
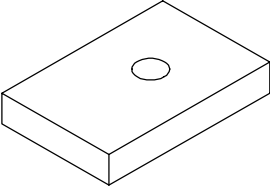
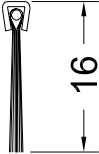
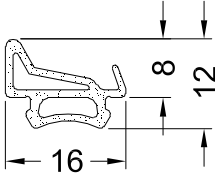
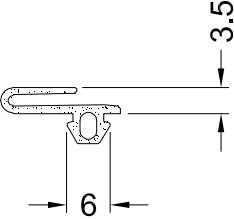

		Verp. per Emb. par Pack pr. Pack pr.	Eenheid Unité Einheit Unit	Toepassing Application Anwendung Application	Kleur Couleur Farbe Color												
	ACDV117 -Support -Support -Support -Support	1	Stuk Pièce Stück Piece	ACDV116 ACDV715 ACDV720 ACDV721 DV10	<table border="1"> <tr><td>BR</td><td></td></tr> <tr><td>AN</td><td></td></tr> <tr><td>KL</td><td></td></tr> <tr><td>GS</td><td></td></tr> <tr><td>Z</td><td></td></tr> <tr><td>W</td><td></td></tr> </table>	BR		AN		KL		GS		Z		W	
BR																	
AN																	
KL																	
GS																	
Z																	
W																	
	ACDV118 -Support -Support -Support -Support	1	Stuk Pièce Stück Piece	ACDV116 ACDV715 ACDV720 ACDV721 DV31	<table border="1"> <tr><td>BR</td><td></td></tr> <tr><td>AN</td><td></td></tr> <tr><td>KL</td><td></td></tr> <tr><td>GS</td><td></td></tr> <tr><td>Z</td><td></td></tr> <tr><td>W</td><td></td></tr> </table>	BR		AN		KL		GS		Z		W	
BR																	
AN																	
KL																	
GS																	
Z																	
W																	
	ACDV201 -Borsteldichting onderkant deur -Brosse desous de porte -Bursten dichtung für türen -Sill gasket	3	m	DV20 DV70 DV21 DV70	<table border="1"> <tr><td>BR</td><td></td></tr> <tr><td>AN</td><td></td></tr> <tr><td>KL</td><td></td></tr> <tr><td>GS</td><td></td></tr> <tr><td>Z</td><td></td></tr> <tr><td>W</td><td></td></tr> </table>	BR		AN		KL		GS		Z		W	
BR																	
AN																	
KL																	
GS																	
Z																	
W																	
	ACDV202N -Vleugel dichting -Joint vantail -Flugel dichtung -Vent gasket	25	m	DV20 DV31 DV10 DV21 DV52	<table border="1"> <tr><td>BR</td><td></td></tr> <tr><td>AN</td><td></td></tr> <tr><td>KL</td><td></td></tr> <tr><td>GS</td><td></td></tr> <tr><td>Z</td><td></td></tr> <tr><td>W</td><td></td></tr> </table>	BR		AN		KL		GS		Z		W	
BR																	
AN																	
KL																	
GS																	
Z																	
W																	
	ACDV203 -Middendichting -Joint central -Mittel dichtung -Central gasket	200	m	DV20 DV52	<table border="1"> <tr><td>BR</td><td></td></tr> <tr><td>AN</td><td></td></tr> <tr><td>KL</td><td></td></tr> <tr><td>GS</td><td></td></tr> <tr><td>Z</td><td></td></tr> <tr><td>W</td><td></td></tr> </table>	BR		AN		KL		GS		Z		W	
BR																	
AN																	
KL																	
GS																	
Z																	
W																	

BR = BRUT - BRUT - ROH - BRUT
 AN (X) = ANODISATIE - ANODISE - ELOXIERT - ANODISED
 AN (■) = GELAKT - LAQUE - LACKIERT - LACQUERED -- RAL9006M
 KL = STANDAARDKLEUREN - COULEUR STANDARD - BASIS FARBEN - BASIC COLORS
 GS = GEMOFFELD SPECIAAL - LAQUE SPECIAL - SPECIALFARBE - SPECIAL COLOR
 Z = ZWART - NOIR - SCHWARZ - BLACK
 W = WIT - BLANC - WEISS - WHITE

 GEREEDSCHAP - OUTILLAGE
 WERKZEUG - TOOL
 BEVESTIGING - FIXATION
 BEFESTIGUNG - FIXATION

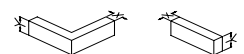

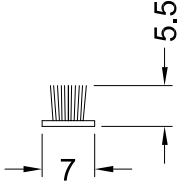
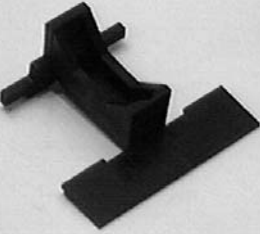
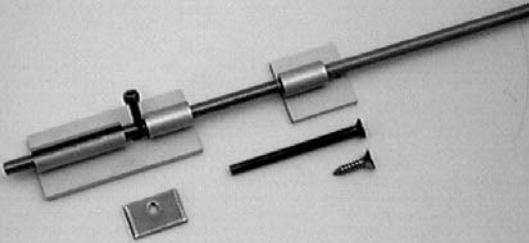
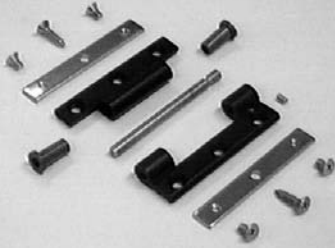
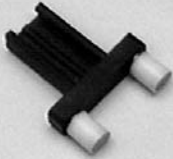

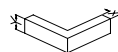
	Verp. per Emb. par Pack pr.	Einheid Unité Einheit Unit	Toepassing Application Anwendung Application	Kleur Couleur Farbe Color												
 <p>ACDV205</p> <ul style="list-style-type: none"> -Dichtingsborstel -Brosse d'étanchéité -Dichtungsborste -Weatherstrip 	20	m	DV10	<table border="1"> <tr><td>BR</td><td></td></tr> <tr><td>AN</td><td></td></tr> <tr><td>KL</td><td></td></tr> <tr><td>GS</td><td></td></tr> <tr><td>Z</td><td></td></tr> <tr><td>W</td><td></td></tr> </table>	BR		AN		KL		GS		Z		W	
BR																
AN																
KL																
GS																
Z																
W																
 <p>ACDV206</p> <ul style="list-style-type: none"> -Dichtingsblok -Pièce de joint -Dichtungsstück -Weathering piece 	1	Stuk Pièce Stück Pièce	DV31	<table border="1"> <tr><td>BR</td><td></td></tr> <tr><td>AN</td><td></td></tr> <tr><td>KL</td><td></td></tr> <tr><td>GS</td><td></td></tr> <tr><td>Z</td><td></td></tr> <tr><td>W</td><td></td></tr> </table>	BR		AN		KL		GS		Z		W	
BR																
AN																
KL																
GS																
Z																
W																
 <p>ACDV207</p> <ul style="list-style-type: none"> -Grendel -Verrou -Schieber -Bar 	1	Stuk Pièce Stück Pièce	DV31	<table border="1"> <tr><td>BR</td><td></td></tr> <tr><td>AN</td><td>X</td></tr> <tr><td>KL</td><td></td></tr> <tr><td>GS</td><td></td></tr> <tr><td>Z</td><td></td></tr> <tr><td>W</td><td></td></tr> </table>	BR		AN	X	KL		GS		Z		W	
BR																
AN	X															
KL																
GS																
Z																
W																
 <p>ACDV208</p> <ul style="list-style-type: none"> -Opschroefscharnier zwart -Charnière à visser noir -Band zum schrauben schwarz -Hinge with screw fitting black 	1	Stuk Pièce Stück Pièce	DV10 DV20 DV21 DV31	<table border="1"> <tr><td>BR</td><td></td></tr> <tr><td>AN</td><td></td></tr> <tr><td>KL</td><td></td></tr> <tr><td>GS</td><td></td></tr> <tr><td>Z</td><td></td></tr> <tr><td>W</td><td></td></tr> </table>	BR		AN		KL		GS		Z		W	
BR																
AN																
KL																
GS																
Z																
W																
 <p>ACDV209</p> <ul style="list-style-type: none"> -Bovenste glijblok -Block de guidage supérieur -Oben fuhrungsstück -Upper sliding block 	1	Stuk Pièce Stück Pièce	DV31	<table border="1"> <tr><td>BR</td><td></td></tr> <tr><td>AN</td><td></td></tr> <tr><td>KL</td><td></td></tr> <tr><td>GS</td><td></td></tr> <tr><td>Z</td><td></td></tr> <tr><td>W</td><td></td></tr> </table>	BR		AN		KL		GS		Z		W	
BR																
AN																
KL																
GS																
Z																
W																







		Verp. per Emb. par Pack pr. Pack pr.	Eenheid Unité Einheit Unit	Toepassing Application Anwendung Application	Kleur Couleur Farbe Color												
	ACDV210 -Loopwagen -Roulettes -Laufwerk -Rolling block	1	Stuk Pièce Stück Piece	DV31 VG53	<table border="1"> <tr><td>BR</td><td></td></tr> <tr><td>AN</td><td></td></tr> <tr><td>KL</td><td></td></tr> <tr><td>GS</td><td></td></tr> <tr><td>Z</td><td></td></tr> <tr><td>W</td><td></td></tr> </table>	BR		AN		KL		GS		Z		W	
BR																	
AN																	
KL																	
GS																	
Z																	
W																	
	ACDV210B -Loopwagen met kunststof wiel -Bogie avec roulette en plastique -Laufwerk mit kunststoff Rolle -Rolling block with synthetic pulley	1	Stuk Pièce Stück Piece	DV31 VG53A	<table border="1"> <tr><td>BR</td><td></td></tr> <tr><td>AN</td><td></td></tr> <tr><td>KL</td><td></td></tr> <tr><td>GS</td><td></td></tr> <tr><td>Z</td><td></td></tr> <tr><td>W</td><td></td></tr> </table>	BR		AN		KL		GS		Z		W	
BR																	
AN																	
KL																	
GS																	
Z																	
W																	
	ACDV212 -Veiligheidsslotje -Serrure de sécurité -Sicherheitsschloss -Security lock DIN963 M5x40/DIN9793 4,8 x 38	1	Stuk Pièce Stück Piece	DV20 DV21 DV31	<table border="1"> <tr><td>BR</td><td></td></tr> <tr><td>AN</td><td></td></tr> <tr><td>KL</td><td></td></tr> <tr><td>GS</td><td></td></tr> <tr><td>Z</td><td></td></tr> <tr><td>W</td><td></td></tr> </table>	BR		AN		KL		GS		Z		W	
BR																	
AN																	
KL																	
GS																	
Z																	
W																	
	ACDV213 -Eindstuk voor stangsluiting -Embout pour serrure -Endstück für schloss -Top piece for lock	1	Stuk Pièce Stück Piece	DV31 ACDV212	<table border="1"> <tr><td>BR</td><td></td></tr> <tr><td>AN</td><td></td></tr> <tr><td>KL</td><td></td></tr> <tr><td>GS</td><td></td></tr> <tr><td>Z</td><td></td></tr> <tr><td>W</td><td></td></tr> </table>	BR		AN		KL		GS		Z		W	
BR																	
AN																	
KL																	
GS																	
Z																	
W																	
	ACDV214 -Stang met draad -Tige avec bout fileté -Stange mit gewinde -Bolt with threaded end	1	Set	ACDV212	<table border="1"> <tr><td>BR</td><td></td></tr> <tr><td>AN</td><td></td></tr> <tr><td>KL</td><td></td></tr> <tr><td>GS</td><td></td></tr> <tr><td>Z</td><td></td></tr> <tr><td>W</td><td></td></tr> </table>	BR		AN		KL		GS		Z		W	
BR																	
AN																	
KL																	
GS																	
Z																	
W																	

BR = BRUT - BRUT - ROH - BRUT
 AN (X) = ANODISATIE - ANODISE - ELOXIERT - ANODISED
 AN (■) = GELAKT - LAQUE - LACKIERT - LACQUERED -- RAL9006M
 KL = STANDAARDKLEUREN - COULEUR STANDARD - BASIS FARBEN - BASIC COLORS
 GS = GEMOFFELD SPECIAAL - LAQUE SPECIAL - SPECIALFARBE - SPECIAL COLOR
 Z = ZWART - NOIR - SCHWARZ - BLACK
 W = WIT - BLANC - WEISS - WHITE

 GEREEDSCHAP - OUTILLAGE
 WERKZEUG - TOOL
 BEVESTIGING - FIXATION
 BEFESTIGUNG - FIXATION

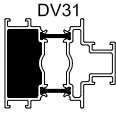

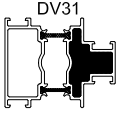
	Verp. per Emb. par Pack pr.	Einheid Unité Einheit Unit	Toepassing Application Anwendung Application	Kleur Couleur Farbe Color												
 <p>ACDV215 -Cilinder -Cylindre -Zylinder -Cylinder 40/40</p>	1	Stuk Pièce Stück Piece		<table border="1"> <tr><td>BR</td><td></td></tr> <tr><td>AN</td><td></td></tr> <tr><td>KL</td><td></td></tr> <tr><td>GS</td><td></td></tr> <tr><td>Z</td><td></td></tr> <tr><td>W</td><td></td></tr> </table>	BR		AN		KL		GS		Z		W	
BR																
AN																
KL																
GS																
Z																
W																
 <p>ACDV219A -Eindstuk -Embout -Endstück -End piece</p> 	1	Stuk Pièce Stück Piece	DV31 DV70	<table border="1"> <tr><td>BR</td><td></td></tr> <tr><td>AN</td><td></td></tr> <tr><td>KL</td><td></td></tr> <tr><td>GS</td><td></td></tr> <tr><td>Z</td><td></td></tr> <tr><td>W</td><td></td></tr> </table>	BR		AN		KL		GS		Z		W	
BR																
AN																
KL																
GS																
Z																
W																
 <p>ACDV219B -Eindstuk -Embout -Endstück -End piece</p> 	1	Stuk Pièce Stück Piece	DV31 DV70	<table border="1"> <tr><td>BR</td><td></td></tr> <tr><td>AN</td><td></td></tr> <tr><td>KL</td><td></td></tr> <tr><td>GS</td><td></td></tr> <tr><td>Z</td><td></td></tr> <tr><td>W</td><td></td></tr> </table>	BR		AN		KL		GS		Z		W	
BR																
AN																
KL																
GS																
Z																
W																

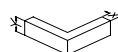

	Verp. per Emb. par Pack pr. Pack pr.	Eenheid Unité Einheit Unit	Toepassing Application Anwendung Application	Kleur Couleur Farbe Color												
 <p>ACDV220 -Onderlegstuk -Support -Underlegplatte -Bearing plate L = 2m</p>	1	Stuk Pièce Stück Piece	ACDV116 ACDV715	<table border="1"> <tr><td>BR</td><td></td></tr> <tr><td>AN</td><td></td></tr> <tr><td>KL</td><td></td></tr> <tr><td>GS</td><td></td></tr> <tr><td>Z</td><td></td></tr> <tr><td>W</td><td></td></tr> </table>	BR		AN		KL		GS		Z		W	
BR																
AN																
KL																
GS																
Z																
W																

BR = BRUT - BRUT - ROH - BRUT
 AN (X) = ANODISATIE - ANODISE - ELOXIERT - ANODISED
 AN (■) = GELAKT - LAQUE - LACKIERT - LACQUERED -- RAL9006M
 KL = STANDAARDKLEUREN - COULEUR STANDARD - BASIS FARBEN - BASIC COLORS
 GS = GEMOFFELD SPECIAAL - LAQUE SPECIAL - SPECIALFARBE - SPECIAL COLOR
 Z = ZWART - NOIR - SCHWARZ - BLACK
 W = WIT - BLANC - WEISS - WHITE





GEREEDSCHAP - OUTILLAGE
WERKZEUG - TOOL

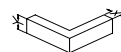

BEVESTIGING - FIXATION
BEFESTIGUNG - FIXATION

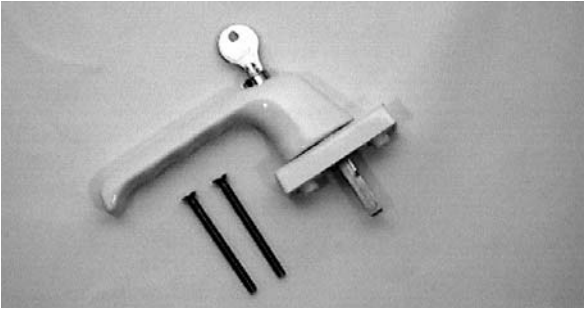

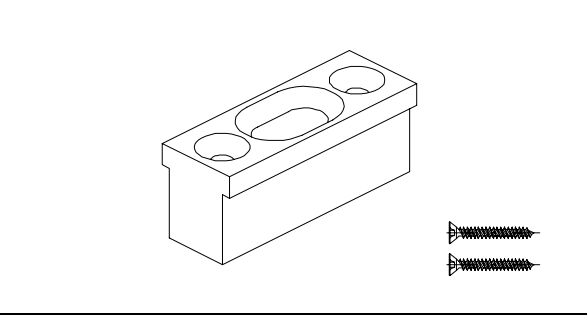
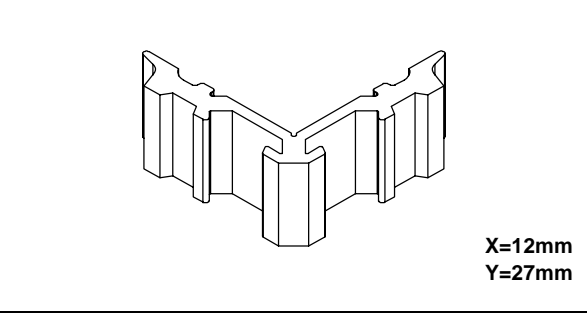
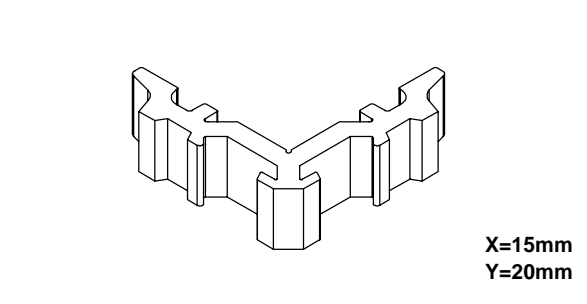
	Verp. per Emb. par Pack pr.	Einheid Unit	Toepassing Application	Kleur Couleur												
 <p>ACDV223 -Halve kruk met cilinder + stift 7mm -Demi poignée avec cylindre + tige 7mm -Halbe druecker mit Zylinder + stift 7mm -Half handle with cilinder + pin 7mm</p>	1	Stuk Pièce Stück Pièce		<table border="1"> <tr><td>BR</td><td></td></tr> <tr><td>AN</td><td></td></tr> <tr><td>KL</td><td></td></tr> <tr><td>GS</td><td></td></tr> <tr><td>Z</td><td></td></tr> <tr><td>W</td><td>X</td></tr> </table>	BR		AN		KL		GS		Z		W	X
BR																
AN																
KL																
GS																
Z																
W	X															
 <p>ACDV235 -Doorslag -Poinçon -Schlagdum -Pin punch</p>	1	Stuk Pièce Stück Pièce	ACDV11 ACDV13 ACDV15	<table border="1"> <tr><td>BR</td><td></td></tr> <tr><td>AN</td><td></td></tr> <tr><td>KL</td><td></td></tr> <tr><td>GS</td><td></td></tr> <tr><td>Z</td><td></td></tr> <tr><td>W</td><td></td></tr> </table>	BR		AN		KL		GS		Z		W	
BR																
AN																
KL																
GS																
Z																
W																
 <p>ACDV236 -Slotplaat voor stangenslot -Gache pour serrure à tringle -Schliessplatte für Treibriegel -Lock plate for door bolt</p>	1	Stuk Pièce Stück Pièce	DV10 DV20 DV21 ACDV212 ACDV214	<table border="1"> <tr><td>BR</td><td></td></tr> <tr><td>AN</td><td></td></tr> <tr><td>KL</td><td></td></tr> <tr><td>GS</td><td></td></tr> <tr><td>Z</td><td></td></tr> <tr><td>W</td><td></td></tr> </table>	BR		AN		KL		GS		Z		W	
BR																
AN																
KL																
GS																
Z																
W																
 <p>ACDV310A -Pershoek voor buitenste kamer -Clame à presser pour chambre extérieure -Eckverbinder stanbar für aussere kammer -Clamping corner for outside chamber</p> <p>X=12mm Y=27mm</p>	1	Stuk Pièce Stück Pièce	DV313	<table border="1"> <tr><td>BR</td><td></td></tr> <tr><td>AN</td><td></td></tr> <tr><td>KL</td><td></td></tr> <tr><td>GS</td><td></td></tr> <tr><td>Z</td><td></td></tr> <tr><td>W</td><td></td></tr> </table>	BR		AN		KL		GS		Z		W	
BR																
AN																
KL																
GS																
Z																
W																
 <p>ACDV310B -Pershoek voor binnenste kamer -Clame à presser pour chambre intérieure -Eckverbinder stanbar für innere kammer -Clamping corner for inside chamber</p> <p>X=15mm Y=20mm</p>	1	Stuk Pièce Stück Pièce	DV313	<table border="1"> <tr><td>BR</td><td></td></tr> <tr><td>AN</td><td></td></tr> <tr><td>KL</td><td></td></tr> <tr><td>GS</td><td></td></tr> <tr><td>Z</td><td></td></tr> <tr><td>W</td><td></td></tr> </table>	BR		AN		KL		GS		Z		W	
BR																
AN																
KL																
GS																
Z																
W																



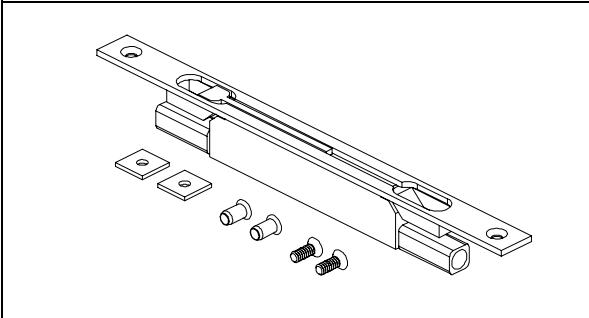

		Verp. per Emb. par Pack pr. Pack pr.	Eenheid Unité Einheit Unit	Toepassing Application Anwendung Application	Kleur Couleur Farbe Color												
	<p>ACDV313</p> <p>-Eindstuk voor stangensluiting -Embout pour serrure -Endstück für Schloss -Top piece for lock</p>	1	Stuk Pièce Stück Piece	DV31 ACVL127	<table border="1"> <tr><td>BR</td><td></td></tr> <tr><td>AN</td><td></td></tr> <tr><td>KL</td><td></td></tr> <tr><td>GS</td><td></td></tr> <tr><td>Z</td><td></td></tr> <tr><td>W</td><td></td></tr> </table>	BR		AN		KL		GS		Z		W	
BR																	
AN																	
KL																	
GS																	
Z																	
W																	
	<p>ACDV326</p> <p>-Veiligheidsslotje -Serrure de sécurité -Sicherheitsschloss -Security lock</p>	1	Stuk Pièce Stück Piece	DV31	<table border="1"> <tr><td>BR</td><td></td></tr> <tr><td>AN</td><td></td></tr> <tr><td>KL</td><td></td></tr> <tr><td>GS</td><td></td></tr> <tr><td>Z</td><td></td></tr> <tr><td>W</td><td></td></tr> </table>	BR		AN		KL		GS		Z		W	
BR																	
AN																	
KL																	
GS																	
Z																	
W																	

BR = BRUT - BRUT - ROH - BRUT
 AN (X) = ANODISATIE - ANODISE - ELOXIERT - ANODISED
 AN (■) = GELAKT - LAQUE - LACKIERT - LACQUERED -- RAL9006M
 KL = STANDAARDKLEUREN - COULEUR STANDARD - BASIS FARBEN - BASIC COLORS
 GS = GEMOFFELD SPECIAAL - LAQUE SPECIAL - SPECIALFARBE - SPECIAL COLOR
 Z = ZWART - NOIR - SCHWARZ - BLACK
 W = WIT - BLANC - WEISS - WHITE

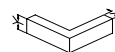

GEREEDSCHAP - OUTILLAGE
 WERKZEUG - TOOL
 BEVESTIGING - FIXATION
 BEFESTIGUNG - FIXATION

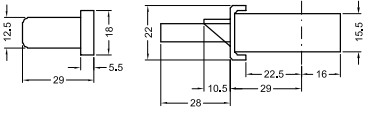

	Verp. per Emb. par Pack pr.	Eenheid Unit	Toepassing Application	Kleur Couleur												
	1	Stuk Pièce Stück Piece	ACDV220	<table border="1"> <tr><td>BR</td><td></td></tr> <tr><td>AN</td><td></td></tr> <tr><td>KL</td><td></td></tr> <tr><td>GS</td><td></td></tr> <tr><td>Z</td><td></td></tr> <tr><td>W</td><td></td></tr> </table>	BR		AN		KL		GS		Z		W	
BR																
AN																
KL																
GS																
Z																
W																
<p>ACDV715</p> <p>-3 Puntslot met pen -Serrure 3 points avec pene -3 Punkt schloss mit falle -Lock with 3 points with pen</p> 																





BR = BRUT - BRUT - ROH - BRUT
 AN (X) = ANODISATIE - ANODISE - ELOXIERT - ANODISED
 AN (■) = GELAKT - LAQUE - LACKIERT - LACQUERED -- RAL9006M
 KL = STANDAARDKLEUREN - COULEUR STANDARD - BASIS FARBEN - BASIC COLORS
 GS = GEMOFFELD SPECIAAL - LAQUE SPECIAL - SPECIALFARBE - SPECIAL COLOR
 Z = ZWART - NOIR - SCHWARZ - BLACK
 W = WIT - BLANC - WEISS - WHITE



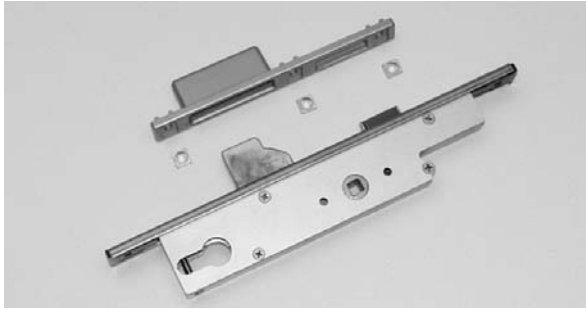
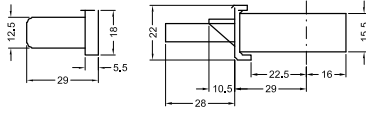
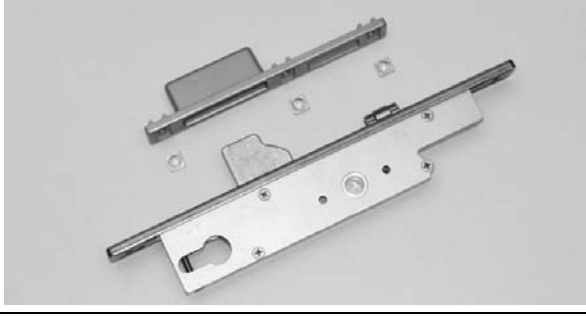
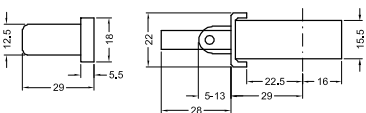
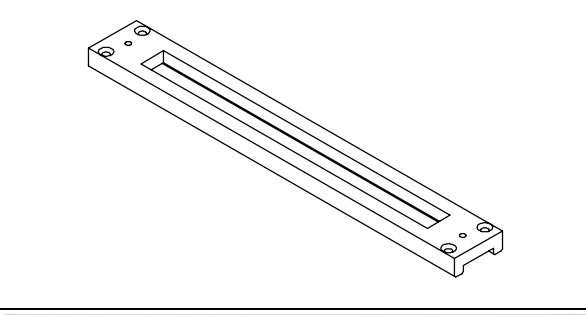

GEREEDSCHAP - OUTILLAGE
WERKZEUG - TOOL

BEVESTIGING - FIXATION
BEFESTIGUNG - FIXATION



		Verp. per Emb. par Pack pr. Pack pr.	Eenheid Unité Einheit Unit	Toepassing Application Anwendung Application	Kleur Couleur Farbe Color												
	<p>ACDV720</p> <p>-1 Puntslot met pen -Serrure 1 points avec pene -1 Punkt schloss mit falle -Lock with 1 points with pen</p> 	1	Stuk Pièce Stück Piece	ACDV117 ACDV118	<table border="1"> <tr><td>BR</td><td></td></tr> <tr><td>AN</td><td></td></tr> <tr><td>KL</td><td></td></tr> <tr><td>GS</td><td></td></tr> <tr><td>Z</td><td></td></tr> <tr><td>W</td><td></td></tr> </table>	BR		AN		KL		GS		Z		W	
BR																	
AN																	
KL																	
GS																	
Z																	
W																	
	<p>ACDV721</p> <p>-1 Puntslot met rol -Serrure 1 points avec rouleau -1 Punkt schloss mit rolle -Lock with 1 points</p> 	1	Stuk Pièce Stück Piece	ACDV117 ACDV118	<table border="1"> <tr><td>BR</td><td></td></tr> <tr><td>AN</td><td></td></tr> <tr><td>KL</td><td></td></tr> <tr><td>GS</td><td></td></tr> <tr><td>Z</td><td></td></tr> <tr><td>W</td><td></td></tr> </table>	BR		AN		KL		GS		Z		W	
BR																	
AN																	
KL																	
GS																	
Z																	
W																	
	<p>ACDV725</p> <p>-Onderlegstuk -Support -Underlegplatte -Support</p>	1	Stuk Pièce Stück Piece	ACDV720 ACDV721	<table border="1"> <tr><td>BR</td><td></td></tr> <tr><td>AN</td><td></td></tr> <tr><td>KL</td><td></td></tr> <tr><td>GS</td><td></td></tr> <tr><td>Z</td><td></td></tr> <tr><td>W</td><td></td></tr> </table>	BR		AN		KL		GS		Z		W	
BR																	
AN																	
KL																	
GS																	
Z																	
W																	
	<p>ACDR050</p> <p>-Inox schroef -Vis en inox -Inox schraube -Stainless steel screw</p> <p> DIN7981 4.8x32</p>	200	Stuk Pièce Stück Piece		<table border="1"> <tr><td>BR</td><td></td></tr> <tr><td>AN</td><td></td></tr> <tr><td>KL</td><td></td></tr> <tr><td>GS</td><td></td></tr> <tr><td>Z</td><td></td></tr> <tr><td>W</td><td></td></tr> </table>	BR		AN		KL		GS		Z		W	
BR																	
AN																	
KL																	
GS																	
Z																	
W																	
	<p>ACFA120</p> <p>-Deurkruk -Bequille de porte -Turgriff -Doorhandle</p>	1	Stuk Pièce Stück Piece	DV20	<table border="1"> <tr><td>BR</td><td></td></tr> <tr><td>AN</td><td></td></tr> <tr><td>KL</td><td>X</td></tr> <tr><td>GS</td><td>X</td></tr> <tr><td>Z</td><td>X</td></tr> <tr><td>W</td><td>X</td></tr> </table>	BR		AN		KL	X	GS	X	Z	X	W	X
BR																	
AN																	
KL	X																
GS	X																
Z	X																
W	X																



BR = BRUT - BRUT - ROH - BRUT
 AN (X) = ANODISATIE - ANODISE - ELOXIERT - ANODISED
 AN (■) = GELAKT - LAQUE - LACKIERT - LACQUERED -- RAL9006M
 KL = STANDAARDKLEUREN - COULEUR STANDARD - BASIS FARBEN - BASIC COLORS
 GS = GEMOFFELD SPECIAAL - LAQUE SPECIAL - SPECIALFARBE - SPECIAL COLOR
 Z = ZWART - NOIR - SCHWARZ - BLACK
 W = WIT - BLANC - WEISS - WHITE

 GEREEDSCHAP - OUTILLAGE
 WERKZEUG - TOOL
 BEVESTIGING - FIXATION
 BEFESTIGUNG - FIXATION



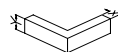

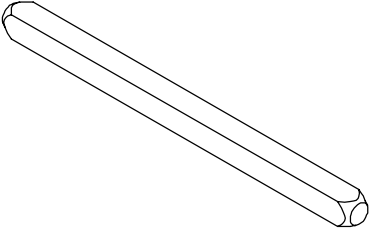
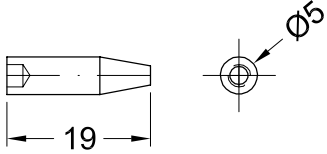
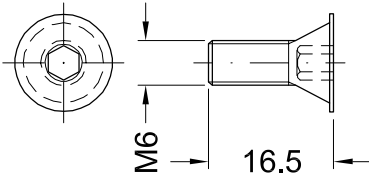
	Verp. per Emb. par Pack pr.	Einheid Unit	Toepassing Application	Kleur Couleur Farbe Color												
 <p>ACFA121 -Bevestigingsblokje -Bloc de fixation -Befestigungsblock -Fixation block</p> <p>X 10</p>	1	Zakje Sachet Beutel Pack	ACFA120	<table border="1"> <tr><td>BR</td><td></td></tr> <tr><td>AN</td><td></td></tr> <tr><td>KL</td><td></td></tr> <tr><td>GS</td><td></td></tr> <tr><td>Z</td><td></td></tr> <tr><td>W</td><td></td></tr> </table>	BR		AN		KL		GS		Z		W	
BR																
AN																
KL																
GS																
Z																
W																
 <p>ACFA211 -Raamkruk vierkant 7 mm -Cremona carré de 7 mm -Fenstergriff vierkant 7 mm -Windowhandle square 7 mm</p>	1	Stuk Pièce Stück Piece	DV20	<table border="1"> <tr><td>BR</td><td></td></tr> <tr><td>AN</td><td>■</td></tr> <tr><td>KL</td><td>X</td></tr> <tr><td>GS</td><td>X</td></tr> <tr><td>Z</td><td>X</td></tr> <tr><td>W</td><td>X</td></tr> </table>	BR		AN	■	KL	X	GS	X	Z	X	W	X
BR																
AN	■															
KL	X															
GS	X															
Z	X															
W	X															
 <p>ACMX108 -Cylinderplaatje -Ecusson lacque -Zylinder-Rosette -Cover</p>	1	Stuk Pièce Stück Piece		<table border="1"> <tr><td>BR</td><td>X</td></tr> <tr><td>AN</td><td>■</td></tr> <tr><td>KL</td><td>X</td></tr> <tr><td>GS</td><td>X</td></tr> <tr><td>Z</td><td>X</td></tr> <tr><td>W</td><td>X</td></tr> </table>	BR	X	AN	■	KL	X	GS	X	Z	X	W	X
BR	X															
AN	■															
KL	X															
GS	X															
Z	X															
W	X															
 <p>ACMX208 -Veiligheidsclinderplaatje -Cache cylindre de sécurité -Sicherheits Zylinder-Rosette -Safetycover for lock</p> <p>h = 10mm</p>	1	Stuk Pièce Stück Piece	ACMX120	<table border="1"> <tr><td>BR</td><td>X</td></tr> <tr><td>AN</td><td>■</td></tr> <tr><td>KL</td><td>X</td></tr> <tr><td>GS</td><td>X</td></tr> <tr><td>Z</td><td>X</td></tr> <tr><td>W</td><td>X</td></tr> </table>	BR	X	AN	■	KL	X	GS	X	Z	X	W	X
BR	X															
AN	■															
KL	X															
GS	X															
Z	X															
W	X															
 <p>ACMX208S -Veiligheidsclinderplaatje -Cache cylindre de sécurité -Sicherheits Zylinder-Rosette -Safetycover for lock</p> <p>h = 10mm</p>	1	Stuk Pièce Stück Piece	ACMX120	<table border="1"> <tr><td>BR</td><td>X</td></tr> <tr><td>AN</td><td>■</td></tr> <tr><td>KL</td><td>X</td></tr> <tr><td>GS</td><td>X</td></tr> <tr><td>Z</td><td>X</td></tr> <tr><td>W</td><td>X</td></tr> </table>	BR	X	AN	■	KL	X	GS	X	Z	X	W	X
BR	X															
AN	■															
KL	X															
GS	X															
Z	X															
W	X															





		Verp. per Emb. par Pack pr. Pack pr.	Eenheid Unité Einheit Unit	Toepassing Application Anwendung Application	Kleur Couleur Farbe Color												
	ACMX309 -Stift voor ACFA120 -Goupille pour ACFA120 -Weschelstift für ACFA120 -Change rod for ACFA120	1	Stuk Pièce Stück Pièce	ACFA120	<table border="1"> <tr><td>BR</td><td></td></tr> <tr><td>AN</td><td></td></tr> <tr><td>KL</td><td></td></tr> <tr><td>GS</td><td></td></tr> <tr><td>Z</td><td></td></tr> <tr><td>W</td><td></td></tr> </table>	BR		AN		KL		GS		Z		W	
BR																	
AN																	
KL																	
GS																	
Z																	
W																	
	ACMX851 -Konische pen 19mm -Goupille conique 19mm -Konische Stift 19mm -Conic pin 19mm	48	Stuk Pièce Stück Pièce		<table border="1"> <tr><td>BR</td><td></td></tr> <tr><td>AN</td><td></td></tr> <tr><td>KL</td><td></td></tr> <tr><td>GS</td><td></td></tr> <tr><td>Z</td><td></td></tr> <tr><td>W</td><td></td></tr> </table>	BR		AN		KL		GS		Z		W	
BR																	
AN																	
KL																	
GS																	
Z																	
W																	
	ACMX852 -Schroef voor T-verbinders -Vis pour assemblage T -Schraube für T-Verbinder -Screw for connecting bracket	48	Stuk Pièce Stück Pièce		<table border="1"> <tr><td>BR</td><td></td></tr> <tr><td>AN</td><td></td></tr> <tr><td>KL</td><td></td></tr> <tr><td>GS</td><td></td></tr> <tr><td>Z</td><td></td></tr> <tr><td>W</td><td></td></tr> </table>	BR		AN		KL		GS		Z		W	
BR																	
AN																	
KL																	
GS																	
Z																	
W																	
 X 10	ACMX862 -DIN965 M5 X 90 -DIN965 M5 X 90 -DIN965 M5 X 90 -DIN965 M5 X 90	1	Stuk Pièce Stück Pièce		<table border="1"> <tr><td>BR</td><td></td></tr> <tr><td>AN</td><td></td></tr> <tr><td>KL</td><td></td></tr> <tr><td>GS</td><td></td></tr> <tr><td>Z</td><td></td></tr> <tr><td>W</td><td></td></tr> </table>	BR		AN		KL		GS		Z		W	
BR																	
AN																	
KL																	
GS																	
Z																	
W																	
	ACMX01603 -Halve cilinder 40mm -Demi-cylindre profile 40mm -Profil-halbzyliner 40mm -Profile half-cylinder 40mm	1	Stuk Pièce Stück Pièce		<table border="1"> <tr><td>BR</td><td></td></tr> <tr><td>AN</td><td></td></tr> <tr><td>KL</td><td></td></tr> <tr><td>GS</td><td></td></tr> <tr><td>Z</td><td></td></tr> <tr><td>W</td><td></td></tr> </table>	BR		AN		KL		GS		Z		W	
BR																	
AN																	
KL																	
GS																	
Z																	
W																	

BR = BRUT - BRUT - ROH - BRUT
 AN (X) = ANODISATIE - ANODISE - ELOXIERT - ANODISED
 AN (■) = GELAKT - LAQUE - LACKIERT - LACQUERED -- RAL9006M
 KL = STANDAARDKLEUREN - COULEUR STANDARD - BASIS FARBEN - BASIC COLORS
 GS = GEMOFFELD SPECIAAL - LAQUE SPECIAL - SPECIALFARBE - SPECIAL COLOR
 Z = ZWART - NOIR - SCHWARZ - BLACK
 W = WIT - BLANC - WEISS - WHITE

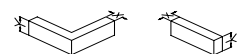
 GEREEDSCHAP - OUTILLAGE
 WERKZEUG - TOOL
 BEVESTIGING - FIXATION
 BEFESTIGUNG - FIXATION

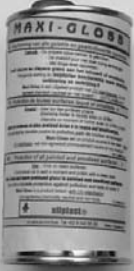

		Verp. per Emb. par Pack pr.	Einheid Unité Einheit Unit	Toepassing Application Anwendung Application	Kleur Couleur Farbe Color												
	ACMX09700 -Alu-polish -Alu-polish -Alu-polish -Alu-polish 750ml	1	Stuk Pièce Stück Pièce	IP010	<table border="1"> <tr><td>BR</td><td></td></tr> <tr><td>AN</td><td></td></tr> <tr><td>KL</td><td></td></tr> <tr><td>GS</td><td></td></tr> <tr><td>Z</td><td></td></tr> <tr><td>W</td><td></td></tr> </table>	BR		AN		KL		GS		Z		W	
BR																	
AN																	
KL																	
GS																	
Z																	
W																	
	ACMX09761 -Maxi-gloss -Maxi-gloss -Maxi-gloss -Maxi-gloss 500ml	1	Stuk Pièce Stück Pièce		<table border="1"> <tr><td>BR</td><td></td></tr> <tr><td>AN</td><td></td></tr> <tr><td>KL</td><td></td></tr> <tr><td>GS</td><td></td></tr> <tr><td>Z</td><td></td></tr> <tr><td>W</td><td></td></tr> </table>	BR		AN		KL		GS		Z		W	
BR																	
AN																	
KL																	
GS																	
Z																	
W																	
	ACMX09762 -Periodi-clean -Periodi-clean -Periodi-clean -Periodi-clean 500ml	1	Stuk Pièce Stück Pièce		<table border="1"> <tr><td>BR</td><td></td></tr> <tr><td>AN</td><td></td></tr> <tr><td>KL</td><td></td></tr> <tr><td>GS</td><td></td></tr> <tr><td>Z</td><td></td></tr> <tr><td>W</td><td></td></tr> </table>	BR		AN		KL		GS		Z		W	
BR																	
AN																	
KL																	
GS																	
Z																	
W																	
	ACMX09763 -Tefon spray -Tefon spray -Tefon spray -Tefon spray 400ml	1	Stuk Pièce Stück Pièce		<table border="1"> <tr><td>BR</td><td></td></tr> <tr><td>AN</td><td></td></tr> <tr><td>KL</td><td></td></tr> <tr><td>GS</td><td></td></tr> <tr><td>Z</td><td></td></tr> <tr><td>W</td><td></td></tr> </table>	BR		AN		KL		GS		Z		W	
BR																	
AN																	
KL																	
GS																	
Z																	
W																	
	ACMX09764 -Maxi-cleaner -Maxi-cleaner -Maxi-cleaner -Maxi-cleaner 500ml	1	Stuk Pièce Stück Pièce		<table border="1"> <tr><td>BR</td><td></td></tr> <tr><td>AN</td><td></td></tr> <tr><td>KL</td><td></td></tr> <tr><td>GS</td><td></td></tr> <tr><td>Z</td><td></td></tr> <tr><td>W</td><td></td></tr> </table>	BR		AN		KL		GS		Z		W	
BR																	
AN																	
KL																	
GS																	
Z																	
W																	

BR = BRUT - BRUT - ROH - BRUT
 AN (X) = ANODISATIE - ANODISE - ELOXIERT - ANODISED
 AN (■) = GELAKT - LAQUE - LACKIERT - LACQUERED -- RAL9006M
 KL = STANDAARDKLEUREN - COULEUR STANDARD - BASIS FARBEN - BASIC COLORS
 GS = GEMOFFELD SPECIAAL - LAQUE SPECIAL - SPECIALFARBE - SPECIAL COLOR
 Z = ZWART - NOIR - SCHWARZ - BLACK
 W = WIT - BLANC - WEISS - WHITE



GEREEDSCHAP - OUTILLAGE
WERKZEUG - TOOL



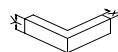

BEVESTIGING - FIXATION
BEFESTIGUNG - FIXATION







		Verp. per Emb. par Pack pr. Pack pr.	Eenheid Unité Einheit Unit	Toepassing Application Anwendung Application	Kleur Couleur Farbe Color												
	ACMX09765 -Glue-cleaner -Glue-cleaner -Glue-cleaner -Glue-cleaner 500ml	1	Stuk Pièce Stück Pièce		<table border="1"> <tr><td>BR</td><td></td></tr> <tr><td>AN</td><td></td></tr> <tr><td>KL</td><td></td></tr> <tr><td>GS</td><td></td></tr> <tr><td>Z</td><td></td></tr> <tr><td>W</td><td></td></tr> </table>	BR		AN		KL		GS		Z		W	
BR																	
AN																	
KL																	
GS																	
Z																	
W																	
	ACMX09766 -Surface activator -Surface activator -Surface activator -Surface activator 1l	1	Stuk Pièce Stück Pièce		<table border="1"> <tr><td>BR</td><td></td></tr> <tr><td>AN</td><td></td></tr> <tr><td>KL</td><td></td></tr> <tr><td>GS</td><td></td></tr> <tr><td>Z</td><td></td></tr> <tr><td>W</td><td></td></tr> </table>	BR		AN		KL		GS		Z		W	
BR																	
AN																	
KL																	
GS																	
Z																	
W																	
	ACMX09770 -Rol andywrap 100mm -Rouleau andywrap 100mm -Rolle andywrap 100mm -Roll andywrap 100mm	150	m		<table border="1"> <tr><td>BR</td><td></td></tr> <tr><td>AN</td><td></td></tr> <tr><td>KL</td><td></td></tr> <tr><td>GS</td><td></td></tr> <tr><td>Z</td><td></td></tr> <tr><td>W</td><td></td></tr> </table>	BR		AN		KL		GS		Z		W	
BR																	
AN																	
KL																	
GS																	
Z																	
W																	
	ACMX09775 -Houder andywrap -Manche andywrap -Halter andywrap -Grip andywrap	1	Stuk Pièce Stück Pièce		<table border="1"> <tr><td>BR</td><td></td></tr> <tr><td>AN</td><td></td></tr> <tr><td>KL</td><td></td></tr> <tr><td>GS</td><td></td></tr> <tr><td>Z</td><td></td></tr> <tr><td>W</td><td></td></tr> </table>	BR		AN		KL		GS		Z		W	
BR																	
AN																	
KL																	
GS																	
Z																	
W																	
	ACMX09801 -Beschermtape 50mm (500m) -Tape de protection 50mm (500m) -Schutz klebeband 50mm (500m) -Protective tape 50mm (500m)	1	Stuk Pièce Stück Pièce		<table border="1"> <tr><td>BR</td><td></td></tr> <tr><td>AN</td><td></td></tr> <tr><td>KL</td><td></td></tr> <tr><td>GS</td><td></td></tr> <tr><td>Z</td><td></td></tr> <tr><td>W</td><td></td></tr> </table>	BR		AN		KL		GS		Z		W	
BR																	
AN																	
KL																	
GS																	
Z																	
W																	

BR = BRUT - BRUT - ROH - BRUT
 AN (X) = ANODISATIE - ANODISE - ELOXIERT - ANODISED
 AN (■) = GELAKT - LAQUE - LACKIERT - LACQUERED -- RAL9006M
 KL = STANDAARDKLEUREN - COULEUR STANDARD - BASIS FARBEN - BASIC COLORS
 GS = GEMOFFELD SPECIAAL - LAQUE SPECIAL - SPECIALFARBE - SPECIAL COLOR
 Z = ZWART - NOIR - SCHWARZ - BLACK
 W = WIT - BLANC - WEISS - WHITE

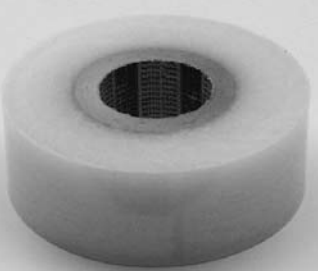
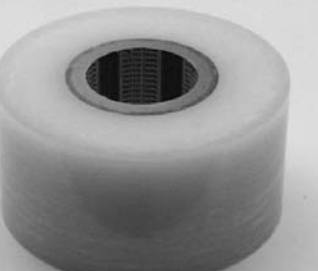
 GEREEDSCHAP - OUTILLAGE
 WERKZEUG - TOOL
 BEVESTIGING - FIXATION
 BEFESTIGUNG - FIXATION



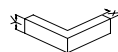

	Verp. per Emb. par Pack pr.	Einheid Unit	Toepassing Application	Kleur Couleur												
 <p>ACMX09802 -Beschermtape 70mm (500m) -Tape de protection 70mm (500m) -Schutz klebeband 70mm (500m) -Protective tape 70mm (500m)</p>	1	Stuk Pièce Stück Piece		<table border="1"> <tr><td>BR</td><td></td></tr> <tr><td>AN</td><td></td></tr> <tr><td>KL</td><td></td></tr> <tr><td>GS</td><td></td></tr> <tr><td>Z</td><td></td></tr> <tr><td>W</td><td></td></tr> </table>	BR		AN		KL		GS		Z		W	
BR																
AN																
KL																
GS																
Z																
W																
 <p>ACMX09803 -Beschermtape 100mm (500m) -Tape de protection 100mm (500m) -Schutz klebeband 100mm (500m) -Protective tape 100mm (500m)</p>	1	Stuk Pièce Stück Piece		<table border="1"> <tr><td>BR</td><td></td></tr> <tr><td>AN</td><td></td></tr> <tr><td>KL</td><td></td></tr> <tr><td>GS</td><td></td></tr> <tr><td>Z</td><td></td></tr> <tr><td>W</td><td></td></tr> </table>	BR		AN		KL		GS		Z		W	
BR																
AN																
KL																
GS																
Z																
W																
 <p>ACMX09804 -Beschermtape 35mm (500m) -Tape de protection 35mm (500m) -Schutz klebeband 35mm (500m) -Protective tape 35mm (500m)</p>	1	Stuk Pièce Stück Piece		<table border="1"> <tr><td>BR</td><td></td></tr> <tr><td>AN</td><td></td></tr> <tr><td>KL</td><td></td></tr> <tr><td>GS</td><td></td></tr> <tr><td>Z</td><td></td></tr> <tr><td>W</td><td></td></tr> </table>	BR		AN		KL		GS		Z		W	
BR																
AN																
KL																
GS																
Z																
W																
 <p>ACMX09830 -Kleefstof voor EPDM-rubbers -Colle pour EPDM-caoutchouc -Dichtmasse + klebestoff EPDM gummi -Gum for EPDM-rubber</p>	1	Stuk Pièce Stück Piece		<table border="1"> <tr><td>BR</td><td></td></tr> <tr><td>AN</td><td></td></tr> <tr><td>KL</td><td></td></tr> <tr><td>GS</td><td></td></tr> <tr><td>Z</td><td>X</td></tr> <tr><td>W</td><td></td></tr> </table>	BR		AN		KL		GS		Z	X	W	
BR																
AN																
KL																
GS																
Z	X															
W																
 <p>ACSIL04 -Afdichtingslijmkit voor versteknaden -Joint d'étanchéité pour onglets -Leim für abdichtung -Sealingglue</p>	1	Stuk Pièce Stück Piece		<table border="1"> <tr><td>BR</td><td></td></tr> <tr><td>AN</td><td></td></tr> <tr><td>KL</td><td></td></tr> <tr><td>GS</td><td></td></tr> <tr><td>Z</td><td>X</td></tr> <tr><td>W</td><td>X</td></tr> </table>	BR		AN		KL		GS		Z	X	W	X
BR																
AN																
KL																
GS																
Z	X															
W	X															







		Verp. per Emb. par Pack pr. Pack pr.	Eenheid Unité Einheit Unit	Toepassing Application Anwendung Application	Kleur Couleur Farbe Color												
	<p>ACSIL08</p> <p>-Siliconenpomp -Pistolet doseur pour les tubes silicones -Handkartuschenpistole für die verarbeitung von silikone und leime -Silicone gun</p>	1	Stuk Pièce Stück Pièce		<table border="1"> <tr><td>BR</td><td></td></tr> <tr><td>AN</td><td></td></tr> <tr><td>KL</td><td></td></tr> <tr><td>GS</td><td></td></tr> <tr><td>Z</td><td></td></tr> <tr><td>W</td><td></td></tr> </table>	BR		AN		KL		GS		Z		W	
BR																	
AN																	
KL																	
GS																	
Z																	
W																	
	<p>ACSIL013</p> <p>-Lijm voor verstekhoek -Colle pour onglet -Kleber für gehrung -Glue for mitre</p>	1	Stuk Pièce Stück Pièce		<table border="1"> <tr><td>BR</td><td></td></tr> <tr><td>AN</td><td></td></tr> <tr><td>KL</td><td></td></tr> <tr><td>GS</td><td></td></tr> <tr><td>Z</td><td></td></tr> <tr><td>W</td><td></td></tr> </table>	BR		AN		KL		GS		Z		W	
BR																	
AN																	
KL																	
GS																	
Z																	
W																	
	<p>ACSIL014</p> <p>-Anticorro - beschermingsproduct -Anticorro - produit de protection -Anticorro - schutzprodukt -Anticorro - protection product</p> <p>500ml</p>	1	Stuk Pièce Stück Pièce		<table border="1"> <tr><td>BR</td><td></td></tr> <tr><td>AN</td><td></td></tr> <tr><td>KL</td><td></td></tr> <tr><td>GS</td><td></td></tr> <tr><td>Z</td><td></td></tr> <tr><td>W</td><td></td></tr> </table>	BR		AN		KL		GS		Z		W	
BR																	
AN																	
KL																	
GS																	
Z																	
W																	
	<p>ACUN020</p> <p>-Klembaar verstekhoekje -Equerre avec fonction de serrage -Eckverbindung mit sperrfunktion -Alignement corner with locking function</p>	10	Stuk Pièce Stück Pièce	DV10 DV20 DV21	<table border="1"> <tr><td>BR</td><td></td></tr> <tr><td>AN</td><td></td></tr> <tr><td>KL</td><td></td></tr> <tr><td>GS</td><td></td></tr> <tr><td>Z</td><td></td></tr> <tr><td>W</td><td></td></tr> </table>	BR		AN		KL		GS		Z		W	
BR																	
AN																	
KL																	
GS																	
Z																	
W																	
	<p>ACVG31</p> <p>-Beglazingsrubber buiten 3mm -Joint de vitrage extérieur 3mm -Glasanlage-dichtung 3mm -Glazing gasket outside 3mm</p>	200	m	DV20 DV21	<table border="1"> <tr><td>BR</td><td></td></tr> <tr><td>AN</td><td></td></tr> <tr><td>KL</td><td></td></tr> <tr><td>GS</td><td></td></tr> <tr><td>Z</td><td></td></tr> <tr><td>W</td><td></td></tr> </table>	BR		AN		KL		GS		Z		W	
BR																	
AN																	
KL																	
GS																	
Z																	
W																	

BR = BRUT - BRUT - ROH - BRUT
 AN (X) = ANODISATIE - ANODISE - ELOXIERT - ANODISED
 AN (■) = GELAKT - LAQUE - LACKIERT - LACQUERED -- RAL9006M
 KL = STANDAARDKLEUREN - COULEUR STANDARD - BASIS FARBEN - BASIC COLORS
 GS = GEMOFFELD SPECIAAL - LAQUE SPECIAL - SPECIALFARBE - SPECIAL COLOR
 Z = ZWART - NOIR - SCHWARZ - BLACK
 W = WIT - BLANC - WEISS - WHITE

 GEREEDSCHAP - OUTILLAGE
 WERKZEUG - TOOL
 BEVESTIGING - FIXATION
 BEFESTIGUNG - FIXATION



		Verp. per Emb. par Pack pr.	Einheid Unité Einheit Unit	Toepassing Application Anwendung Application	Kleur Couleur Farbe Color
	ACVG31N -Beglazingsrubber buiten 3mm ronddraaiend -Joint de vitrage extérieur 3mm tournant -Glasanlage-dichtung 3mm herumdrehend -Glazing gasket outside 3mm rotated	200	m	DV20 DV21	BR AN KL GS Z W
	ACVG32 -Beglazingsrubber 3mm -Joint de vitrage 3mm -Glasdichtung 3mm -Glazing gasket 3mm	100	m	VL61 VL62 VL63 VL64 VL65 VL66 VL610 VL611 VL640	BR AN KL GS Z W
	ACVG32N -Beglazingsrubber 3mm ronddraaiend -Joint de vitrage 3mm tournant -Glasdichtung 3mm herumdrehend -Glazing gasket 3mm rotated	100	m	VL61 VL62 VL63 VL64 VL65 VL66 VL610 VL611 VL640	BR AN KL GS Z W
	ACVG33 -Beglazingsrubber 4mm -Joint de vitrage 4mm -Glasdichtung 4mm -Glazing gasket 4mm	100	m	VL61 VL62 VL63 VL64 VL65 VL66 VL610 VL611 VL640	BR AN KL GS Z W
	ACVG33N -Beglazingsrubber 4mm ronddraaiend -Joint de vitrage 4mm tournant -Glasdichtung 4mm herumdrehend -Glazing gasket 4mm rotated	100	m	VL61 VL62 VL63 VL64 VL65 VL66 VL610 VL611 VL640	BR AN KL GS Z W

BR = BRUT - BRUT - ROH - BRUT
 AN (X) = ANODISATIE - ANODISE - ELOXIERT - ANODISED
 AN (■) = GELAKT - LAQUE - LACKIERT - LACQUERED -- RAL9006M
 KL = STANDAARDKLEUREN - COULEUR STANDARD - BASIS FARBEN - BASIC COLORS
 GS = GEMOFFELD SPECIAAL - LAQUE SPECIAL - SPECIALFARBE - SPECIAL COLOR
 Z = ZWART - NOIR - SCHWARZ - BLACK
 W = WIT - BLANC - WEISS - WHITE







GEREEDSCHAP - OUTILLAGE
WERKZEUG - TOOL

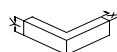

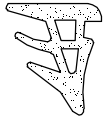

BEVESTIGING - FIXATION
BEFESTIGUNG - FIXATION







		Verp. per Emb. par Pack pr. Pack pr.	Eenheid Unité Einheit Unit	Toepassing Application Anwendung Application	Kleur Couleur Farbe Color												
	ACVG34 -Beglazingsrubber 5mm -Joint de vitrage 5mm -Glasdichtung 5mm -Glazing gasket 5mm	100	m	VL61 VL62 VL63 VL64 VL65 VL66 VL610 VL611 VL640	<table border="1"> <tr><td>BR</td><td></td></tr> <tr><td>AN</td><td></td></tr> <tr><td>KL</td><td></td></tr> <tr><td>GS</td><td></td></tr> <tr><td>Z</td><td></td></tr> <tr><td>W</td><td></td></tr> </table>	BR		AN		KL		GS		Z		W	
BR																	
AN																	
KL																	
GS																	
Z																	
W																	
	ACVG34N -Beglazingsrubber 5mm ronddraaiend -Joint de vitrage 5mm tournant -Glasdichtung 5mm herumdrehend -Glazing gasket 5mm rotated	100	m	VL61 VL62 VL63 VL64 VL65 VL66 VL610 VL611 VL640	<table border="1"> <tr><td>BR</td><td></td></tr> <tr><td>AN</td><td></td></tr> <tr><td>KL</td><td></td></tr> <tr><td>GS</td><td></td></tr> <tr><td>Z</td><td></td></tr> <tr><td>W</td><td></td></tr> </table>	BR		AN		KL		GS		Z		W	
BR																	
AN																	
KL																	
GS																	
Z																	
W																	
	ACVG45 -Afdekkapje waterafvoer -Capuchon écoulement d'eau -Abdeckkappe entwässerung -Drain hole cover	1	Stuk Pièce Stück Piece	VL10 VL11 VL12 VL13 VL14 VL15 VL30 VL31 VL34	<table border="1"> <tr><td>BR</td><td></td></tr> <tr><td>AN</td><td></td></tr> <tr><td>KL</td><td>X</td></tr> <tr><td>GS</td><td></td></tr> <tr><td>Z</td><td>X</td></tr> <tr><td>W</td><td>X</td></tr> </table>	BR		AN		KL	X	GS		Z	X	W	X
BR																	
AN																	
KL	X																
GS																	
Z	X																
W	X																
	ACVG49 -Beglazingsrubber 6-8mm -Joint de vitrage 6-8mm -Glasdichtung 6-8mm -Glazing gasket 6-8mm	100	m	VL61 VL62 VL63 VL64 VL65 VL66 VL610 VL611 VL640	<table border="1"> <tr><td>BR</td><td></td></tr> <tr><td>AN</td><td></td></tr> <tr><td>KL</td><td></td></tr> <tr><td>GS</td><td></td></tr> <tr><td>Z</td><td></td></tr> <tr><td>W</td><td></td></tr> </table>	BR		AN		KL		GS		Z		W	
BR																	
AN																	
KL																	
GS																	
Z																	
W																	
	ACVG65 -Zeskantsleutel 2.5mm -Clé à six pans 2.5mm -Sechskantschlüssel 2.5mm -T-handle hexagon-key 2.5mm	1	Stuk Pièce Stück Piece		<table border="1"> <tr><td>BR</td><td></td></tr> <tr><td>AN</td><td></td></tr> <tr><td>KL</td><td></td></tr> <tr><td>GS</td><td></td></tr> <tr><td>Z</td><td></td></tr> <tr><td>W</td><td></td></tr> </table>	BR		AN		KL		GS		Z		W	
BR																	
AN																	
KL																	
GS																	
Z																	
W																	

BR = BRUT - BRUT - ROH - BRUT
 AN (X) = ANODISATIE - ANODISE - ELOXIERT - ANODISED
 AN (■) = GELAKT - LAQUE - LACKIERT - LACQUERED -- RAL9006M
 KL = STANDAARDKLEUREN - COULEUR STANDARD - BASIS FARBEN - BASIC COLORS
 GS = GEMOFFELD SPECIAAL - LAQUE SPECIAL - SPECIALFARBE - SPECIAL COLOR
 Z = ZWART - NOIR - SCHWARZ - BLACK
 W = WIT - BLANC - WEISS - WHITE

 GEREEDSCHAP - OUTILLAGE
 WERKZEUG - TOOL
 BEVESTIGING - FIXATION
 BEFESTIGUNG - FIXATION



		Verp. per Emb. par Pack pr.	Einheid Unité Einheit Unit	Toepassing Application Anwendung Application	Kleur Couleur Farbe Color												
	ACVG66 -Zeskantsleutel 3mm -Clé à six pans 3mm -Sechskantschlüssel 3mm -T-handle hexagon-key 3mm	1	Stuk Pièce Stück Piece		<table border="1"> <tr><td>BR</td><td></td></tr> <tr><td>AN</td><td></td></tr> <tr><td>KL</td><td></td></tr> <tr><td>GS</td><td></td></tr> <tr><td>Z</td><td></td></tr> <tr><td>W</td><td></td></tr> </table>	BR		AN		KL		GS		Z		W	
BR																	
AN																	
KL																	
GS																	
Z																	
W																	
	ACVG131 -Beglazingsrubber buiten 4mm -Joint de vitrage extérieur 4mm -Glasanlage-dichtung 4mm -Glazing gasket outside 4mm	100	m	DV20 DV21	<table border="1"> <tr><td>BR</td><td></td></tr> <tr><td>AN</td><td></td></tr> <tr><td>KL</td><td></td></tr> <tr><td>GS</td><td></td></tr> <tr><td>Z</td><td></td></tr> <tr><td>W</td><td></td></tr> </table>	BR		AN		KL		GS		Z		W	
BR																	
AN																	
KL																	
GS																	
Z																	
W																	
	ACVG131N -Beglazingsrubber buiten 4mm ronddraaiend -Joint de vitrage extérieur 4mm tournant -Glasanlage-dichtung 4mm herumdrehend -Glazing gasket outside 4mm rotated	100	m	DV20 DV21	<table border="1"> <tr><td>BR</td><td></td></tr> <tr><td>AN</td><td></td></tr> <tr><td>KL</td><td></td></tr> <tr><td>GS</td><td></td></tr> <tr><td>Z</td><td></td></tr> <tr><td>W</td><td></td></tr> </table>	BR		AN		KL		GS		Z		W	
BR																	
AN																	
KL																	
GS																	
Z																	
W																	
	ACVG231 -Beglazingsrubber buiten 2mm -Joint de vitrage extérieur 2mm -Glasanlage-dichtung 2mm -Glazing gasket outside 2mm	200	m	DV20 DV21	<table border="1"> <tr><td>BR</td><td></td></tr> <tr><td>AN</td><td></td></tr> <tr><td>KL</td><td></td></tr> <tr><td>GS</td><td></td></tr> <tr><td>Z</td><td></td></tr> <tr><td>W</td><td></td></tr> </table>	BR		AN		KL		GS		Z		W	
BR																	
AN																	
KL																	
GS																	
Z																	
W																	
	ACVG231N -Beglazingsrubber buiten 2mm ronddraaiend -Joint de vitrage extérieur 2mm tournant -Glasanlage-dichtung 2mm herumdrehend -Glazing gasket outside 2mm rotated	200	m	DV20 DV21	<table border="1"> <tr><td>BR</td><td></td></tr> <tr><td>AN</td><td></td></tr> <tr><td>KL</td><td></td></tr> <tr><td>GS</td><td></td></tr> <tr><td>Z</td><td></td></tr> <tr><td>W</td><td></td></tr> </table>	BR		AN		KL		GS		Z		W	
BR																	
AN																	
KL																	
GS																	
Z																	
W																	

BR = BRUT - BRUT - ROH - BRUT
 AN (X) = ANODISATIE - ANODISE - ELOXIERT - ANODISED
 AN (■) = GELAKT - LAQUE - LACKIERT - LACQUERED -- RAL9006M
 KL = STANDAARDKLEUREN - COULEUR STANDARD - BASIS FARBEN - BASIC COLORS
 GS = GEMOFFELD SPECIAAL - LAQUE SPECIAL - SPECIALFARBE - SPECIAL COLOR
 Z = ZWART - NOIR - SCHWARZ - BLACK
 W = WIT - BLANC - WEISS - WHITE







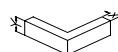

GEREEDSCHAP - OUTILLAGE
 WERKZEUG - TOOL



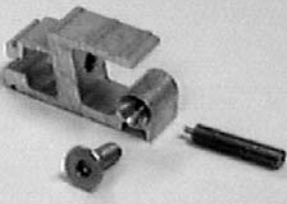

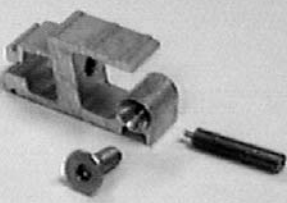
BEVESTIGING - FIXATION
 BEFESTIGUNG - FIXATION

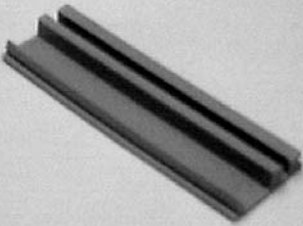

		Verp. per Emb. par Pack pr. Pack pr.	Eenheid Unité Einheit Unit	Toepassing Application Anwendung Application	Kleur Couleur Farbe Color												
	ACVL020 -Verstekhoekje in inox -Equerre de jonction -Eckverstärkung -Framing square	1	Stuk Pièce Stück Pièce	DV10 DV20 DV21	<table border="1"> <tr><td>BR</td><td></td></tr> <tr><td>AN</td><td></td></tr> <tr><td>KL</td><td></td></tr> <tr><td>GS</td><td></td></tr> <tr><td>Z</td><td></td></tr> <tr><td>W</td><td></td></tr> </table>	BR		AN		KL		GS		Z		W	
BR																	
AN																	
KL																	
GS																	
Z																	
W																	
	ACVL020B -Verstekhoekje in kunststof -Equerre de jonction en plastique -Eckverstärkung in plastik -Framing square in plastic	1	Stuk Pièce Stück Pièce	DV10 DV20 DV21	<table border="1"> <tr><td>BR</td><td></td></tr> <tr><td>AN</td><td></td></tr> <tr><td>KL</td><td></td></tr> <tr><td>GS</td><td></td></tr> <tr><td>Z</td><td></td></tr> <tr><td>W</td><td></td></tr> </table>	BR		AN		KL		GS		Z		W	
BR																	
AN																	
KL																	
GS																	
Z																	
W																	
 X=15mm Y=27mm	ACVL025N -T-verbinding -Jonction-T -T-Verbinder -T-bracket  ACVL150/ACVG66	1 24	Stuk Pièce Stück Pièce	DV20 DV21 VL30	<table border="1"> <tr><td>BR</td><td></td></tr> <tr><td>AN</td><td></td></tr> <tr><td>KL</td><td></td></tr> <tr><td>GS</td><td></td></tr> <tr><td>Z</td><td></td></tr> <tr><td>W</td><td></td></tr> </table>	BR		AN		KL		GS		Z		W	
BR																	
AN																	
KL																	
GS																	
Z																	
W																	
 X=41mm Y=27mm	ACVL026 -T-verbinding -Jonction-T -T-Verbinder -T-bracket  ACVL150/ACVG66	1 24	Stuk Pièce Stück Pièce	DV20 DV21 VL31	<table border="1"> <tr><td>BR</td><td></td></tr> <tr><td>AN</td><td></td></tr> <tr><td>KL</td><td></td></tr> <tr><td>GS</td><td></td></tr> <tr><td>Z</td><td></td></tr> <tr><td>W</td><td></td></tr> </table>	BR		AN		KL		GS		Z		W	
BR																	
AN																	
KL																	
GS																	
Z																	
W																	
	ACVL057 -Glassteun -Support calle de vitrage -Klotz-Anflage -Glazing support	1	Stuk Pièce Stück Pièce	DV20 DV21	<table border="1"> <tr><td>BR</td><td></td></tr> <tr><td>AN</td><td></td></tr> <tr><td>KL</td><td></td></tr> <tr><td>GS</td><td></td></tr> <tr><td>Z</td><td></td></tr> <tr><td>W</td><td></td></tr> </table>	BR		AN		KL		GS		Z		W	
BR																	
AN																	
KL																	
GS																	
Z																	
W																	

BR = BRUT - BRUT - ROH - BRUT
 AN (X) = ANODISATIE - ANODISE - ELOXIERT - ANODISED
 AN (■) = GELAKT - LAQUE - LACKIERT - LACQUERED -- RAL9006M
 KL = STANDAARDKLEUREN - COULEUR STANDARD - BASIS FARBEN - BASIC COLORS
 GS = GEMOFFELD SPECIAAL - LAQUE SPECIAL - SPECIALFARBE - SPECIAL COLOR
 Z = ZWART - NOIR - SCHWARZ - BLACK
 W = WIT - BLANC - WEISS - WHITE

 GEREEDSCHAP - OUTILLAGE
 WERKZEUG - TOOL
 BEVESTIGING - FIXATION
 BEFESTIGUNG - FIXATION

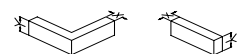

		Verp. per Emb. par Pack pr.	Einheid Unité Einheit Unit	Toepassing Application Anwendung Application	Kleur Couleur Farbe Color
	ACVL127 -Stang 2.5m -Barreau 2.5m -Stange 2.5m -Rod 2.5m	1	Stuk Pièce Stück Piece	ACDV326	BR AN KL GS Z W
	ACVL150 -Zeskantsleutel 4 mm -Clé à six pans 4 mm -Sechskantschlüssel 4 mm -T-handle hexagon-key 4 mm	1	Stuk Pièce Stück Piece		BR AN KL GS Z W
	ACVL159 -Kontaktlijm voor rubber -Colle pour joint -Kleber für Dichtung -Glue for gasket	1	Stuk Pièce Stück Piece		BR AN KL GS Z W
	ACVS010 -Geleidingsstrip -Joint patin -Leitungsstreifen -Sliding strip	7.3	m	DV70	BR AN KL GS Z W
	MA031 -Boormal -Gabarit de forage -Bohrschablone -Drilling jig set	1	Stuk Pièce Stück Piece	DV10	BR AN KL GS Z W

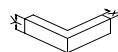

	Verp. per Emb. par Pack pr. Pack pr.	Eenheid Unité Einheit Unit	Toepassing Application Anwendung Application	Kleur Couleur Farbe Color												
 <p>MA032 -Boormal -Gabarit de forage -Bohrschablone -Drilling jig set</p>	1	Stuk Pièce Stück Piece	DV20	<table border="1"> <tr><td>BR</td><td></td></tr> <tr><td>AN</td><td></td></tr> <tr><td>KL</td><td></td></tr> <tr><td>GS</td><td></td></tr> <tr><td>Z</td><td></td></tr> <tr><td>W</td><td></td></tr> </table>	BR		AN		KL		GS		Z		W	
BR																
AN																
KL																
GS																
Z																
W																

BR = BRUT - BRUT - ROH - BRUT
 AN (X) = ANODISATIE - ANODISE - ELOXIERT - ANODISED
 AN (■) = GELAKT - LAQUE - LACKIERT - LACQUERED -- RAL9006M
 KL = STANDAARDKLEUREN - COULEUR STANDARD - BASIS FARBEN - BASIC COLORS
 GS = GEMOFFELD SPECIAAL - LAQUE SPECIAL - SPECIALFARBE - SPECIAL COLOR
 Z = ZWART - NOIR - SCHWARZ - BLACK
 W = WIT - BLANC - WEISS - WHITE



GEREEDSCHAP - OUTILLAGE
WERKZEUG - TOOL



BEVESTIGING - FIXATION
BEFESTIGUNG - FIXATION

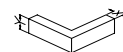

VOUWDEUR NAAR BINNEN OPENEND
PORTES AMOVIBLES OUVRANT INTERIEUR
FALT TÜREN NACH INNEN OFFNEND
FOLDING DOORS INWARDS OPENING

DOORSNEDE - COUPE - SCHNITT - SECTION

Type 1i

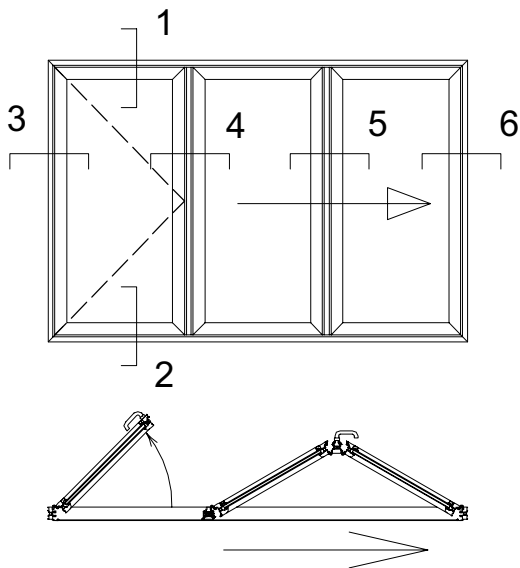

Type 2i

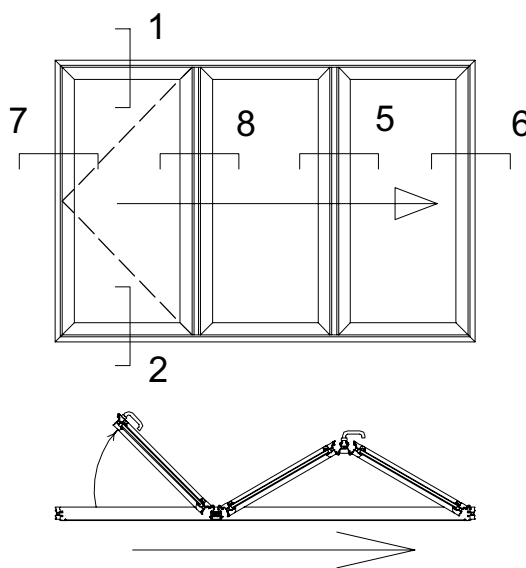

Type 3i

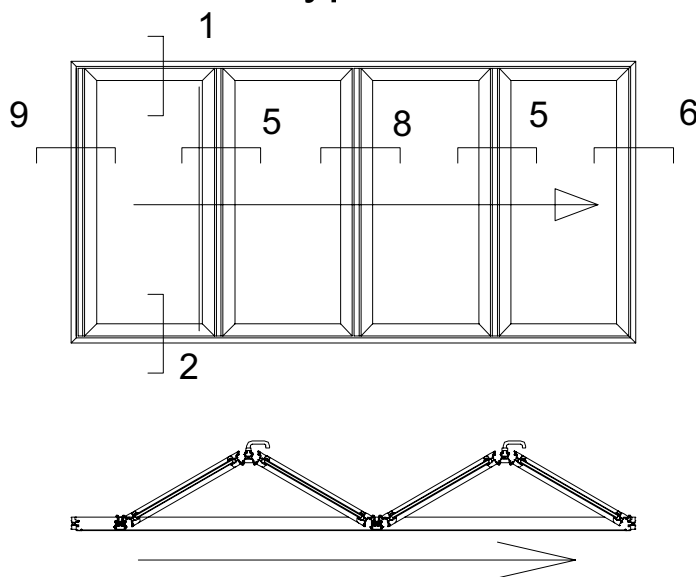

DOORTYP1

VOUWDEUR NAAR BINNEN OPENEND
PORTES AMOVIBLES OUVRANT INTERIEUR
FALT TUREN NACH INNEN OFFNEND
FOLDING DOORS INWARDS OPENING

DOORSNEDE - COUPE - SCHNITT - SECTION

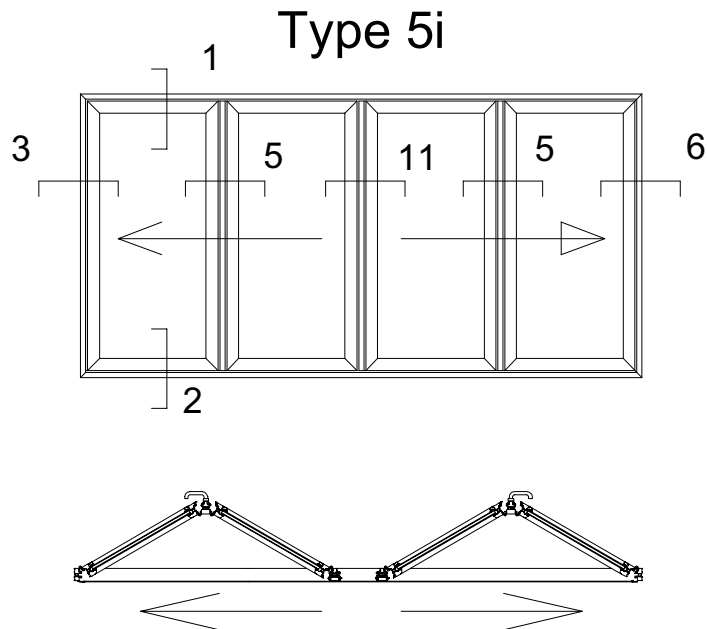
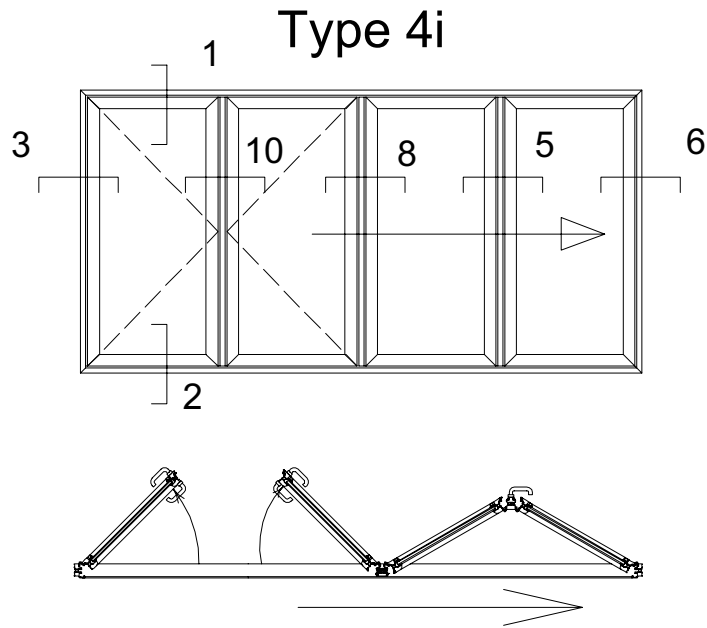

DOORTYP2

VOUWDEUR NAAR BINNEN OPENEND
PORTES AMOVIBLES OUVRANT INTERIEUR
FALT TÜREN NACH INNEN OFFNEND
FOLDING DOORS INWARDS OPENING

DOORSNEDE - COUPE - SCHNITT - SECTION

Type 6i

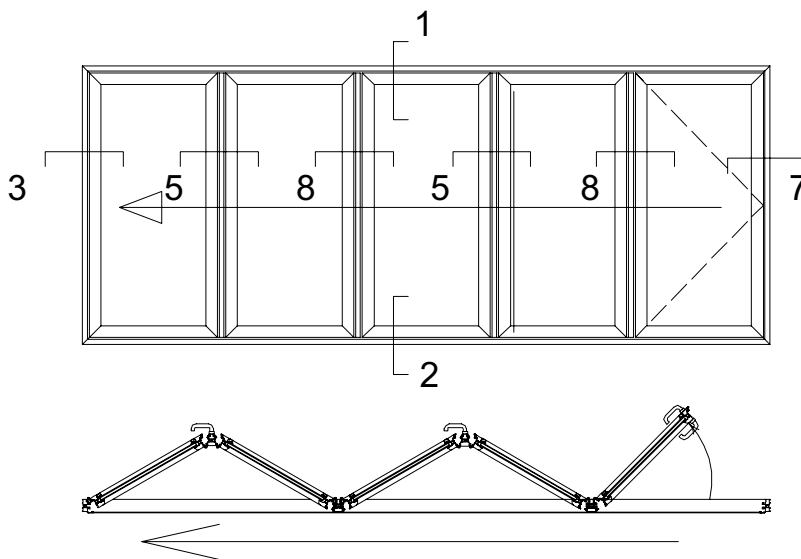

Type 7i

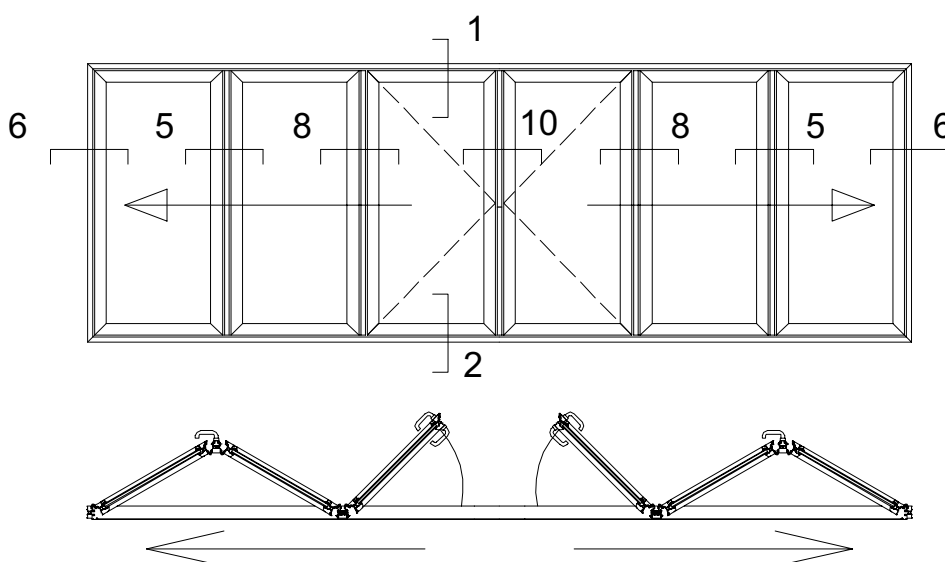

DOORTYP3

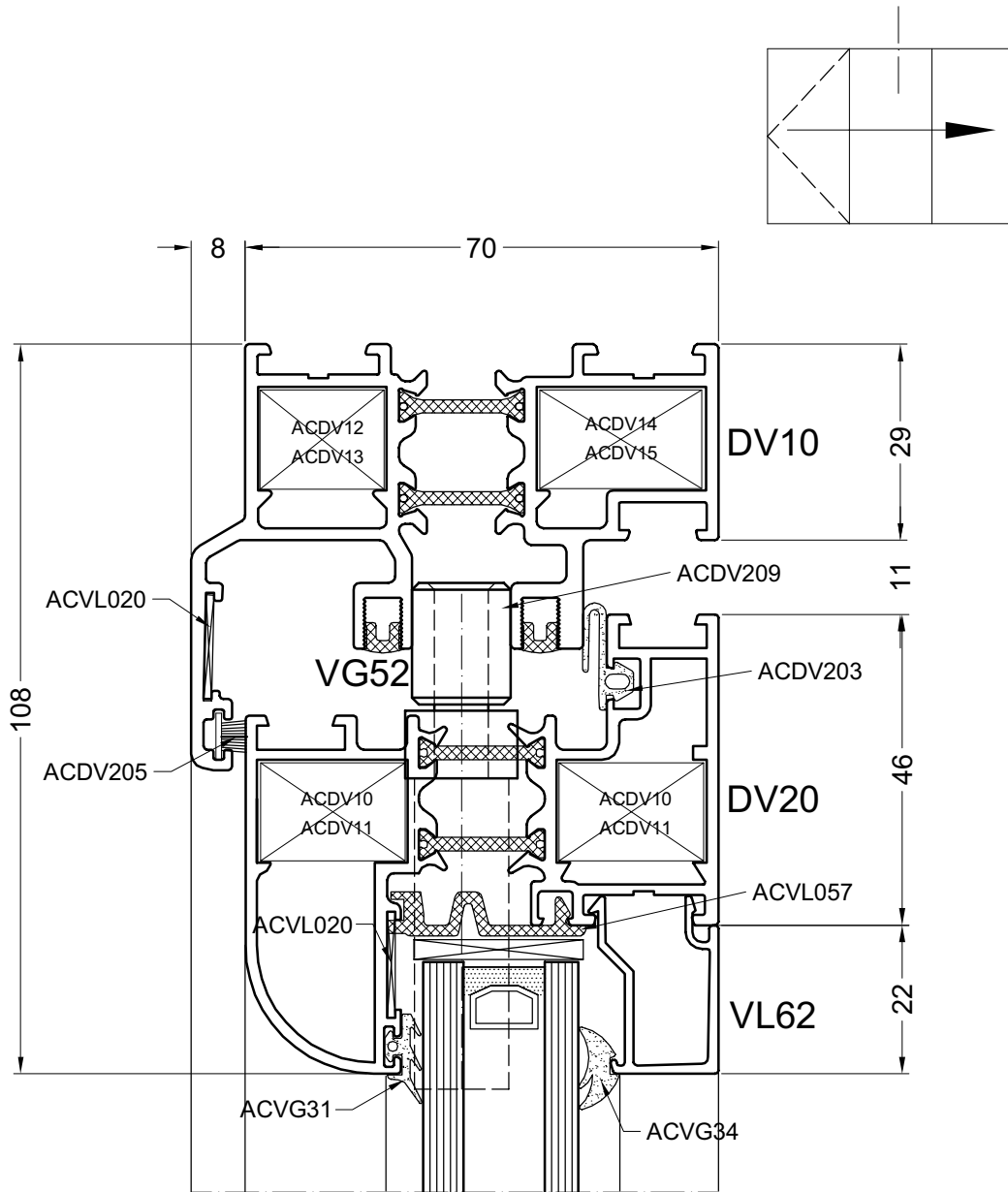

door01

2A

DOORSNEDE - COUPE - SCHNITT - SECTION

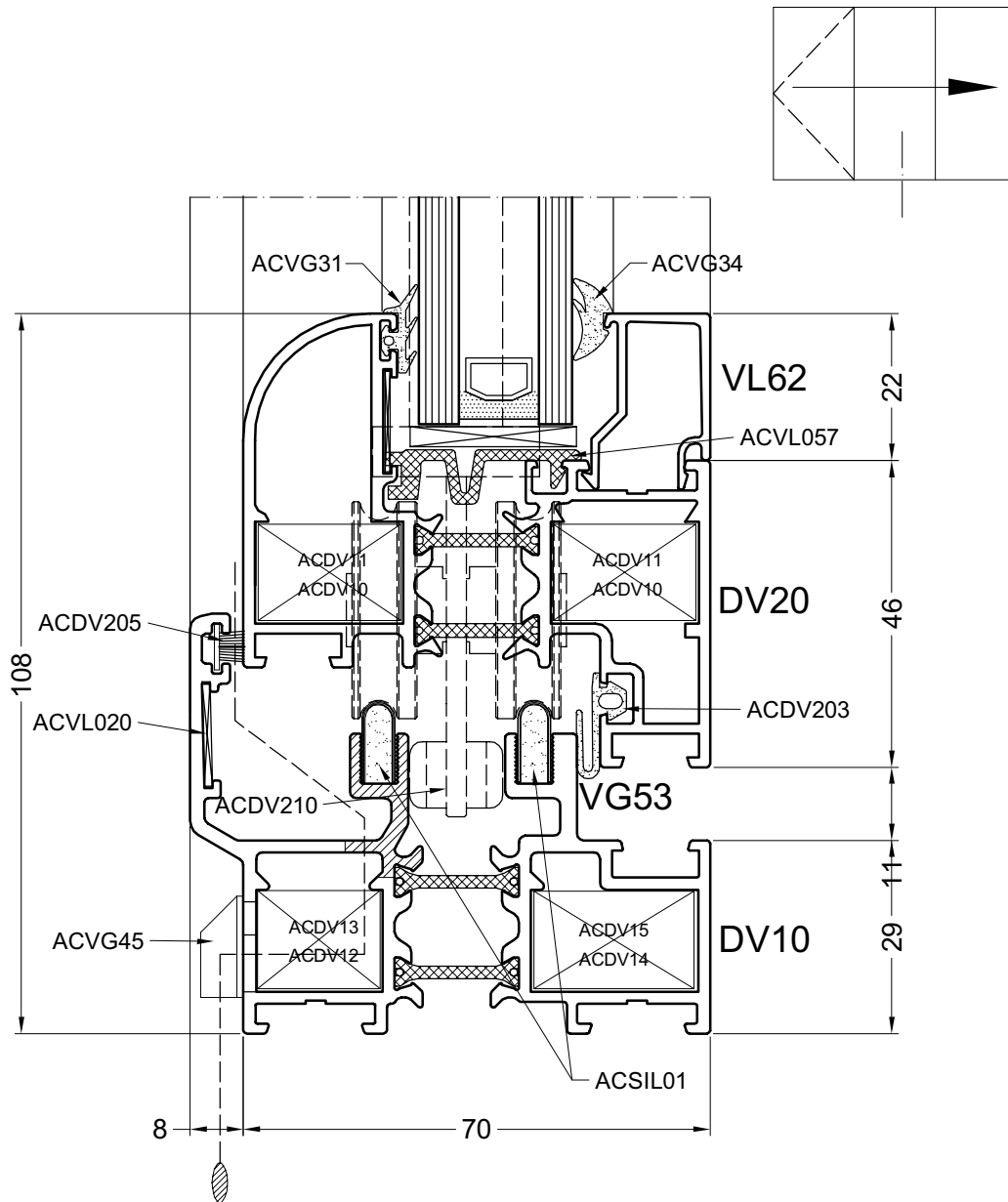

door02a

2B

DOORSNEDE - COUPE - SCHNITT - SECTION

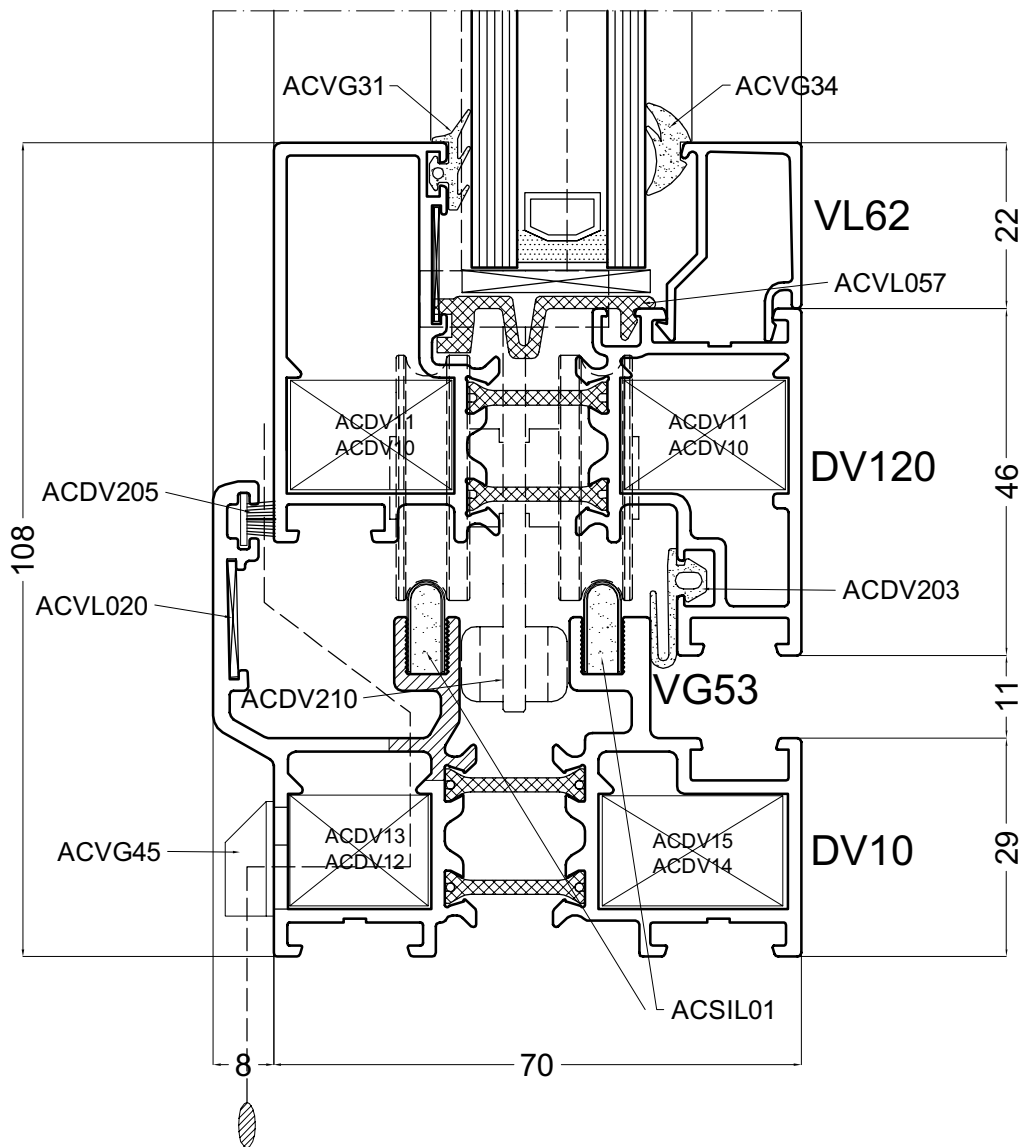
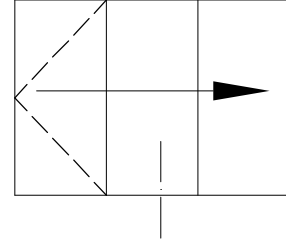

door02f

2C

DOORSNEDE - COUPE - SCHNITT - SECTION

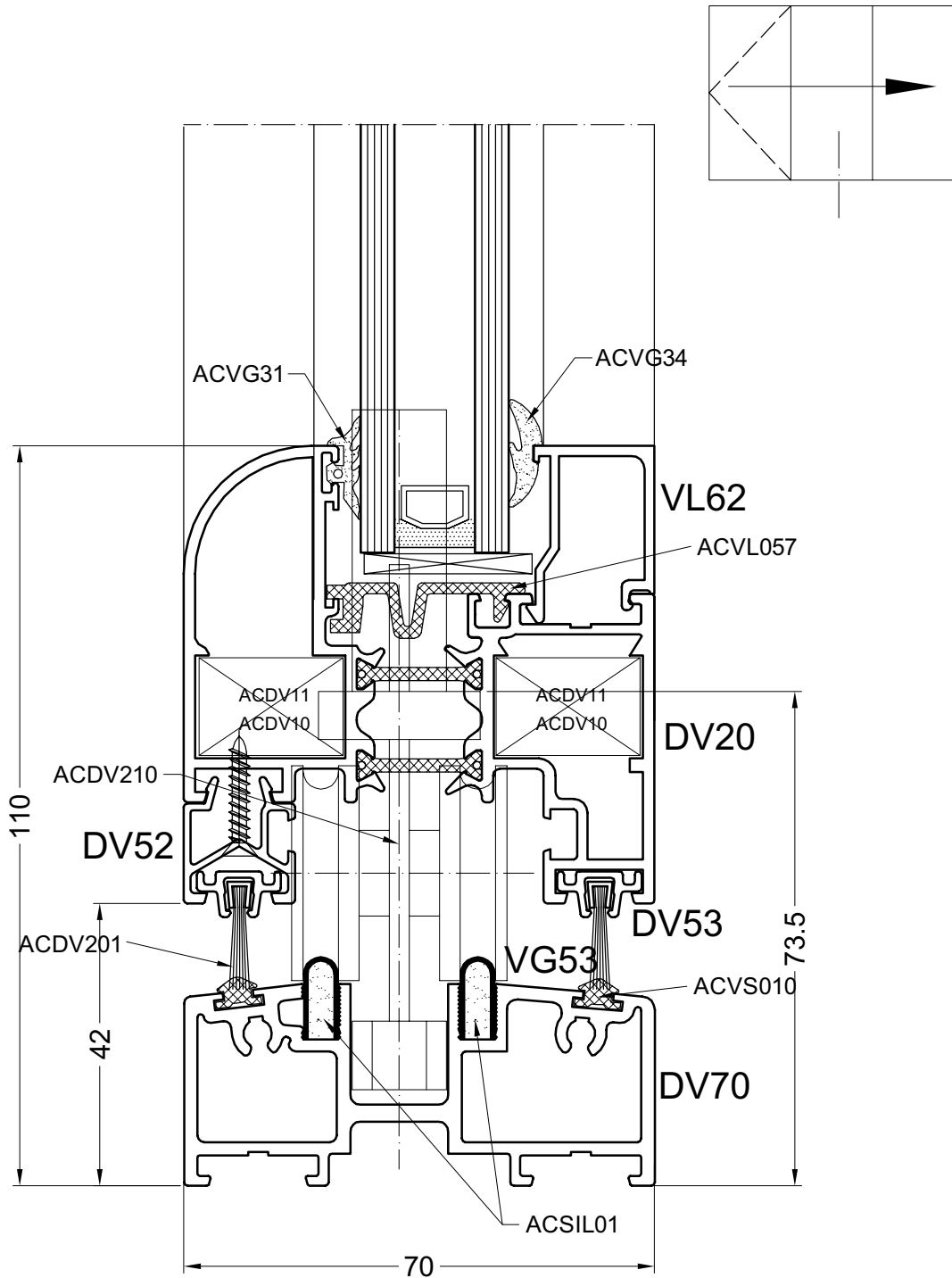

door02b

2D

DOORSNEDE - COUPE - SCHNITT - SECTION

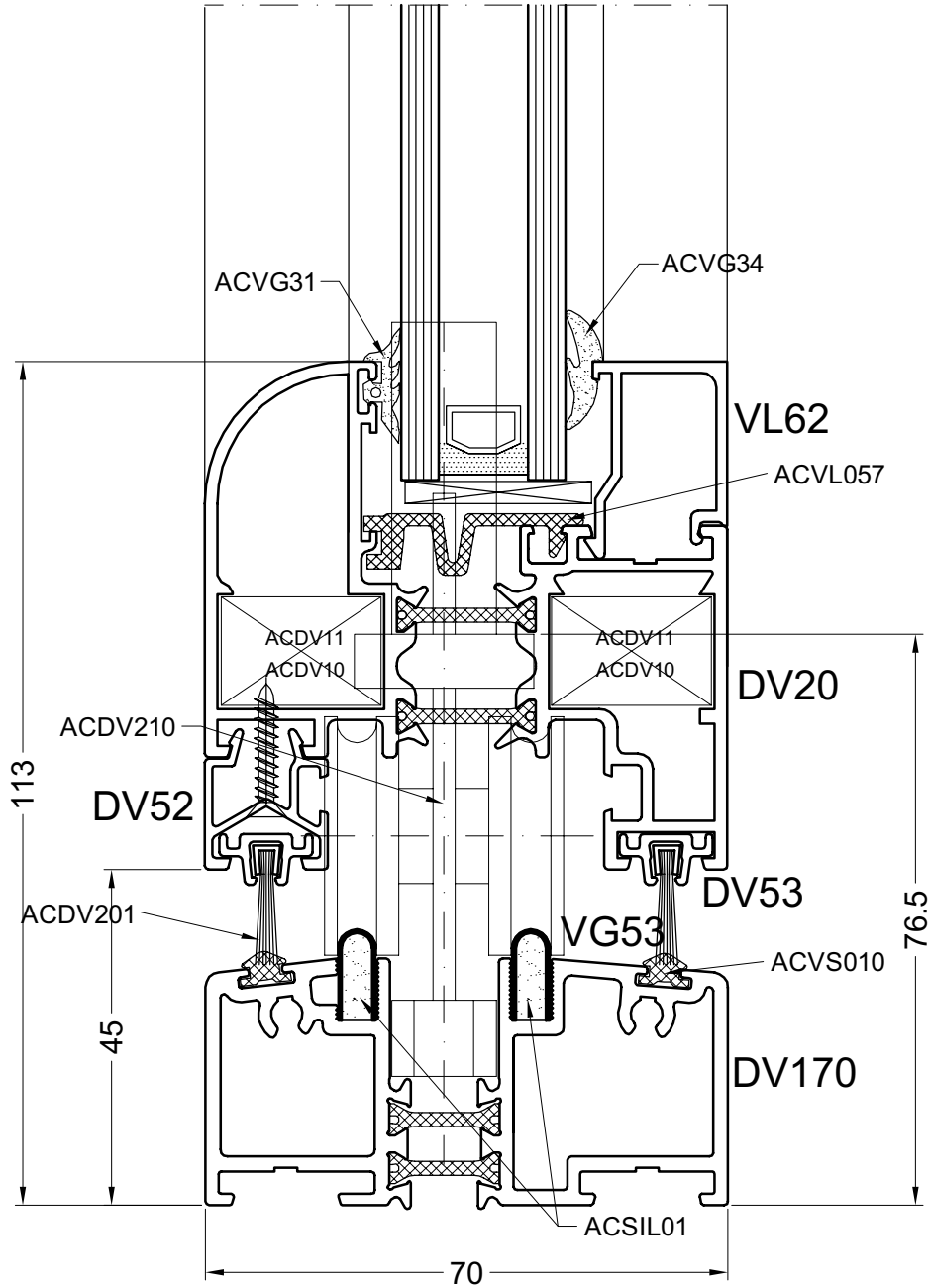
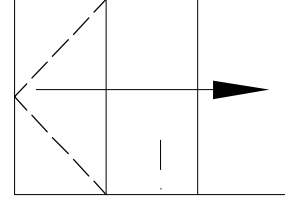

door02e

2E

DOORSNEDE - COUPE - SCHNITT - SECTION

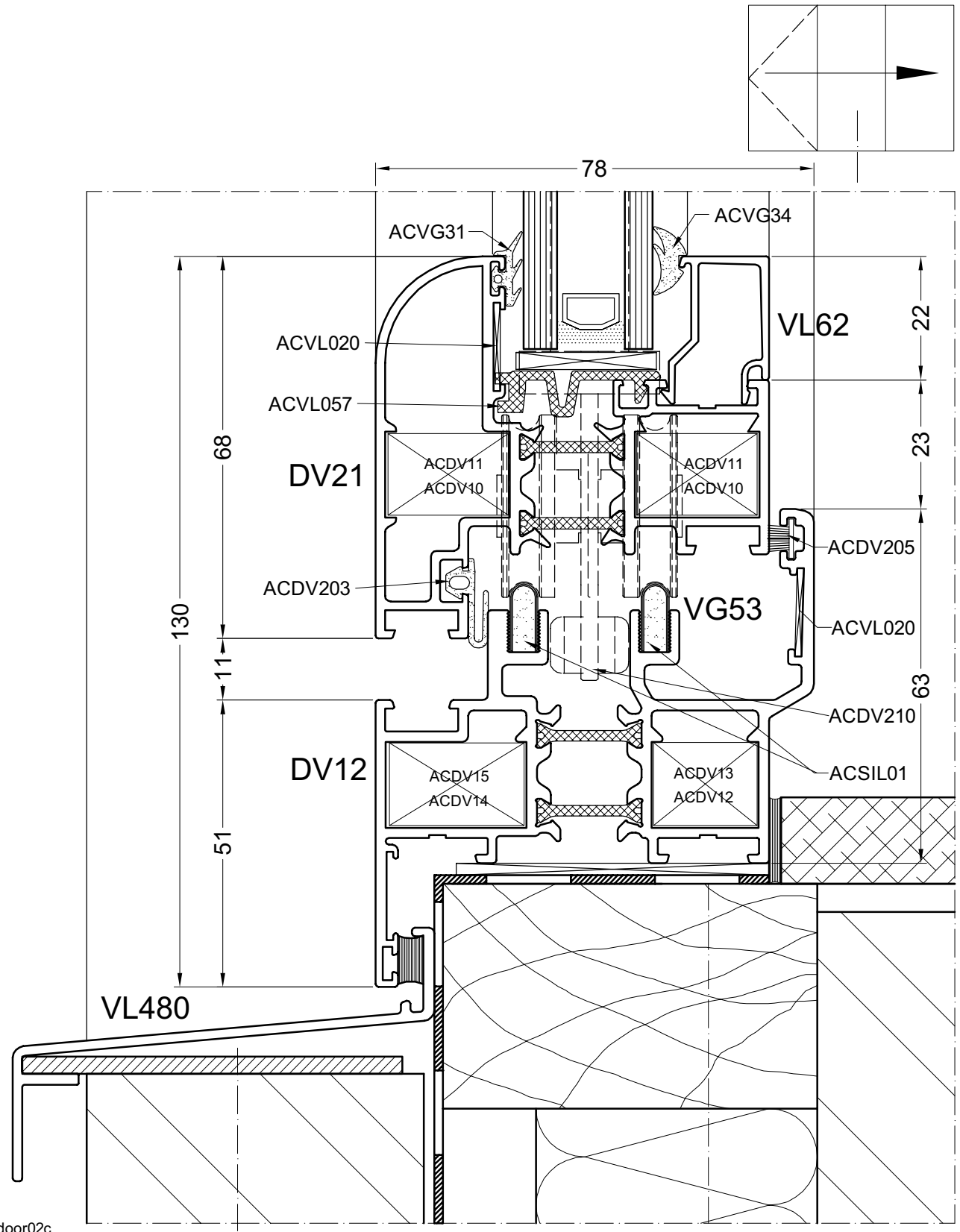

door02c

2F

DOORSNEDE - COUPE - SCHNITT - SECTION

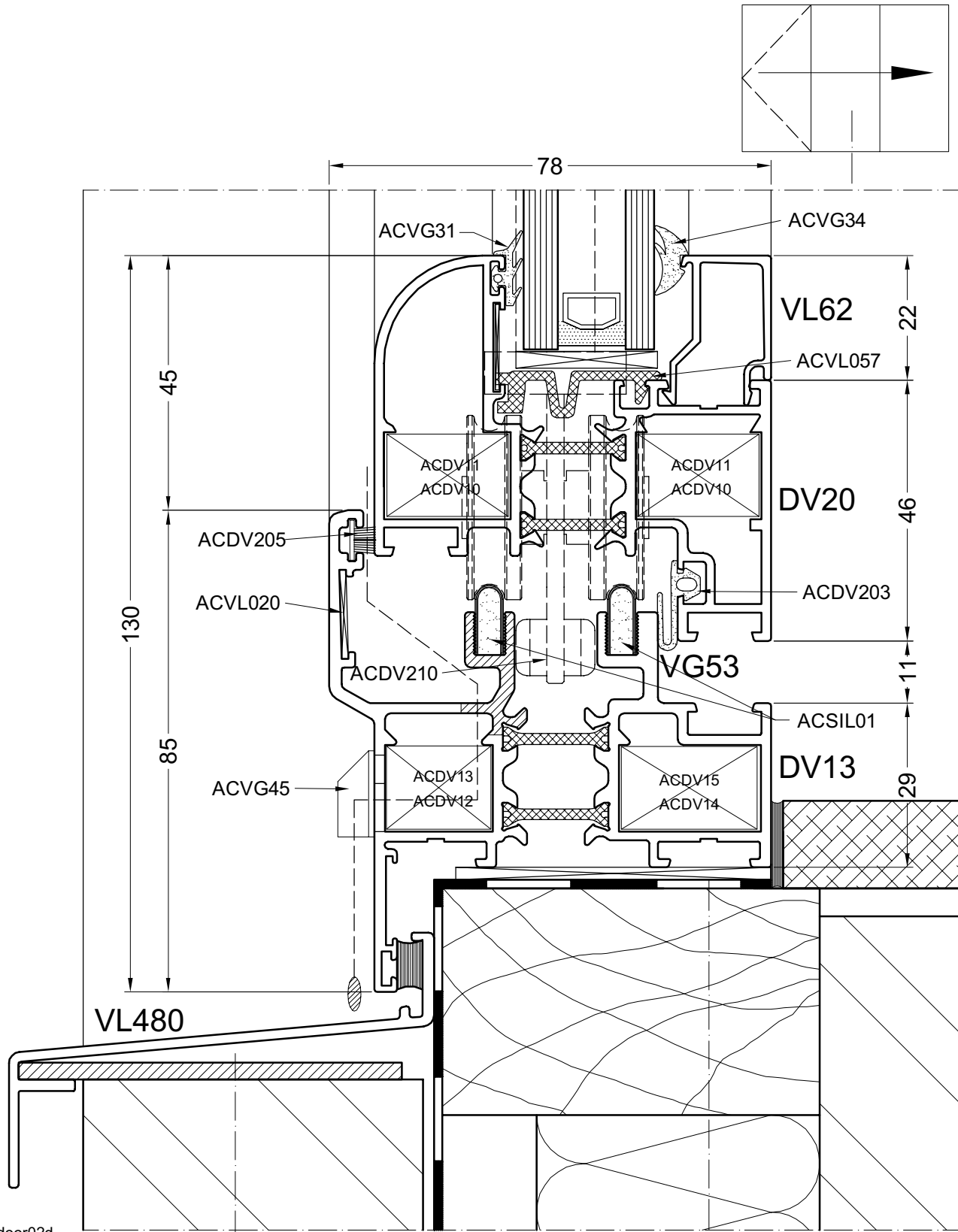

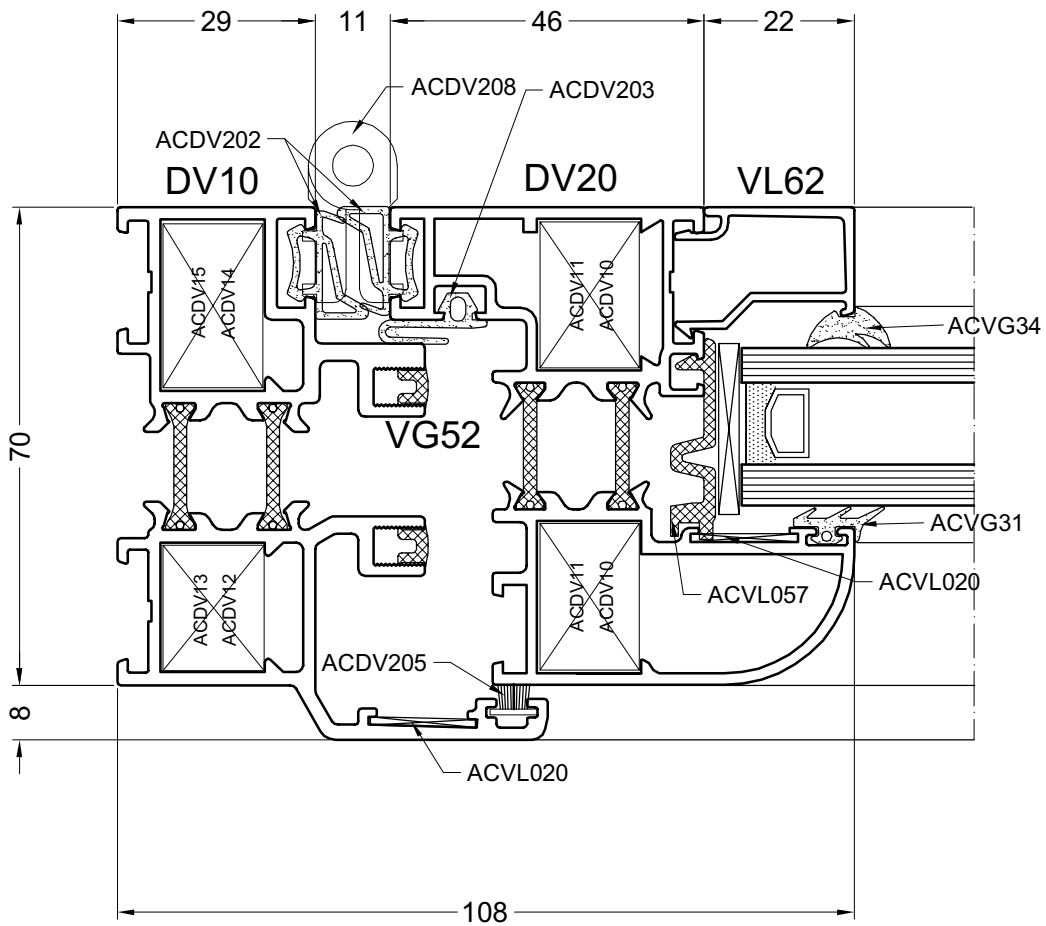
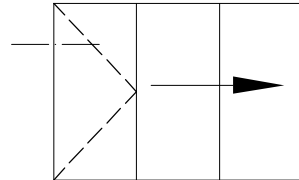

4A

DOORSNEDE - COUPE - SCHNITT - SECTION

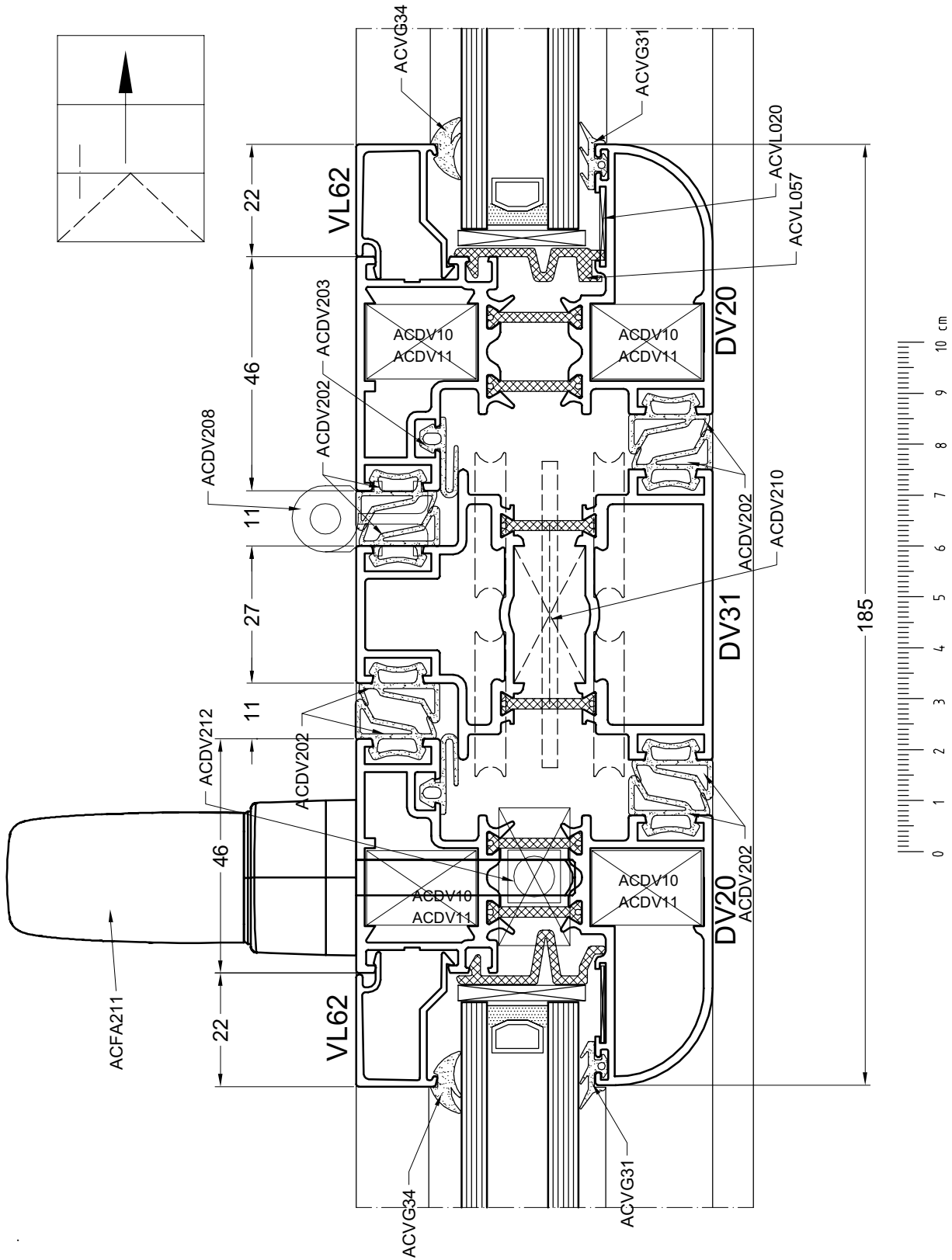

door04a

4B

DOORSNEDE - COUPE - SCHNITT - SECTION

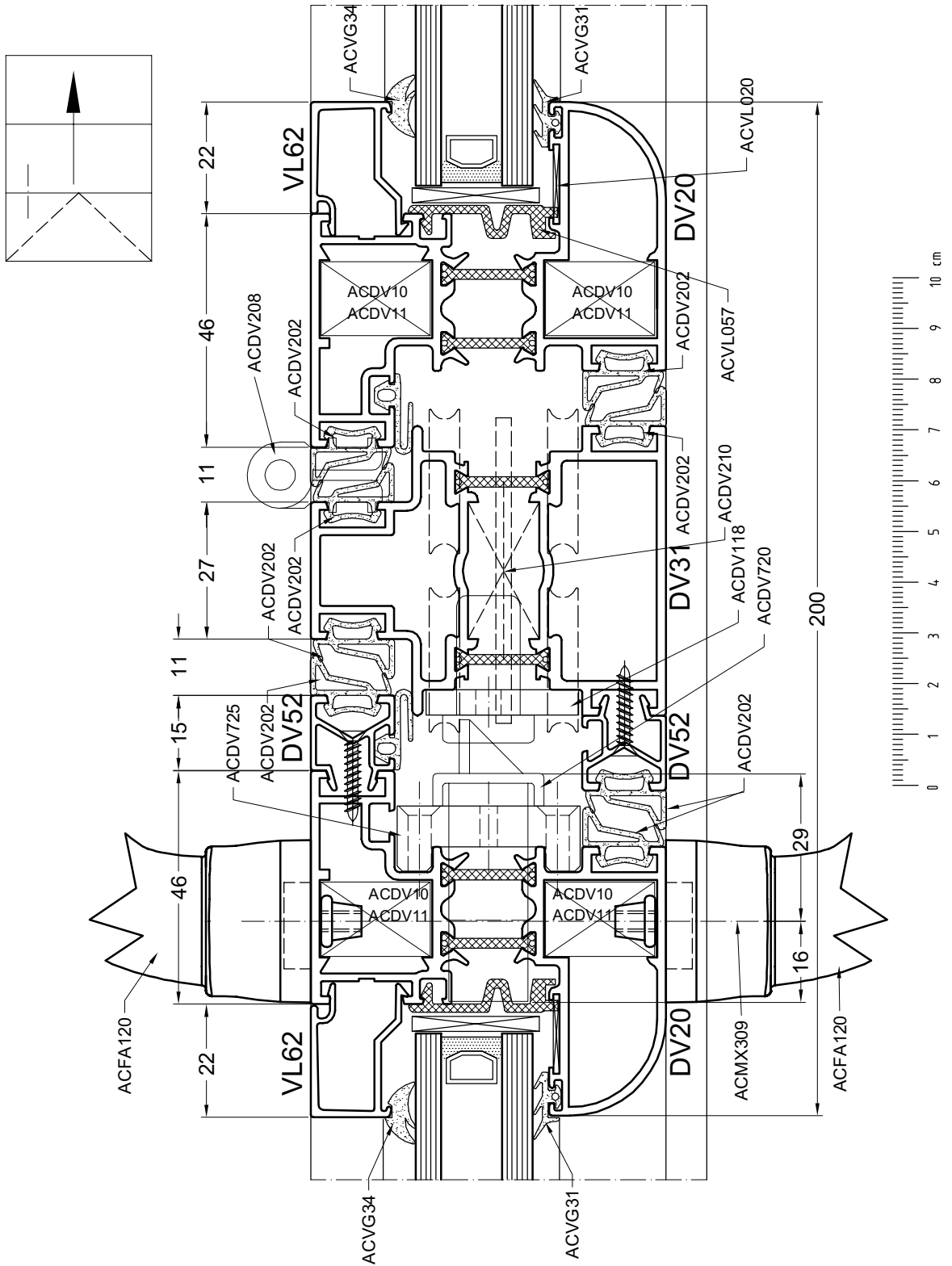

door04b

4C

DOORSNEDE - COUPE - SCHNITT - SECTION

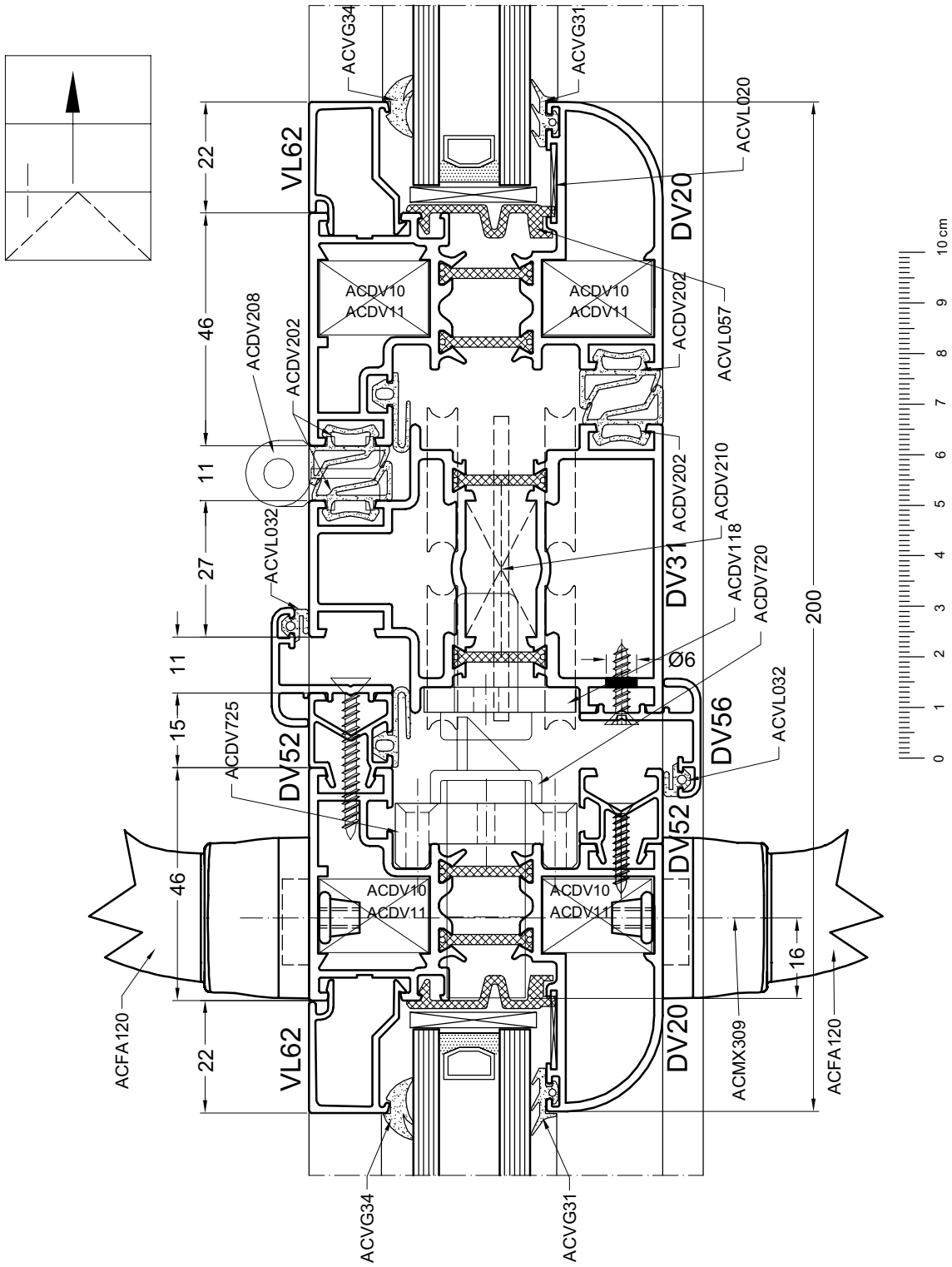

door04c

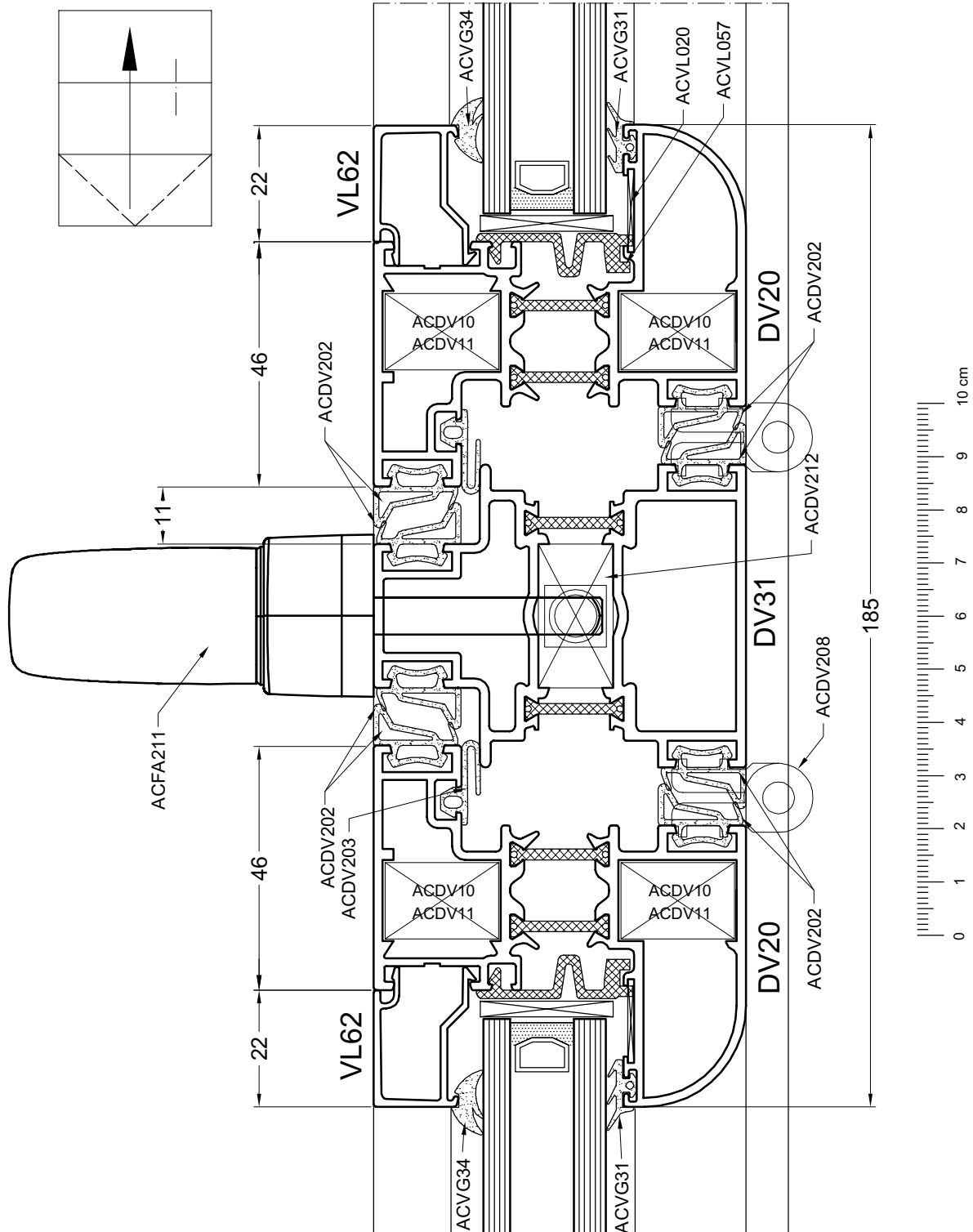

door05

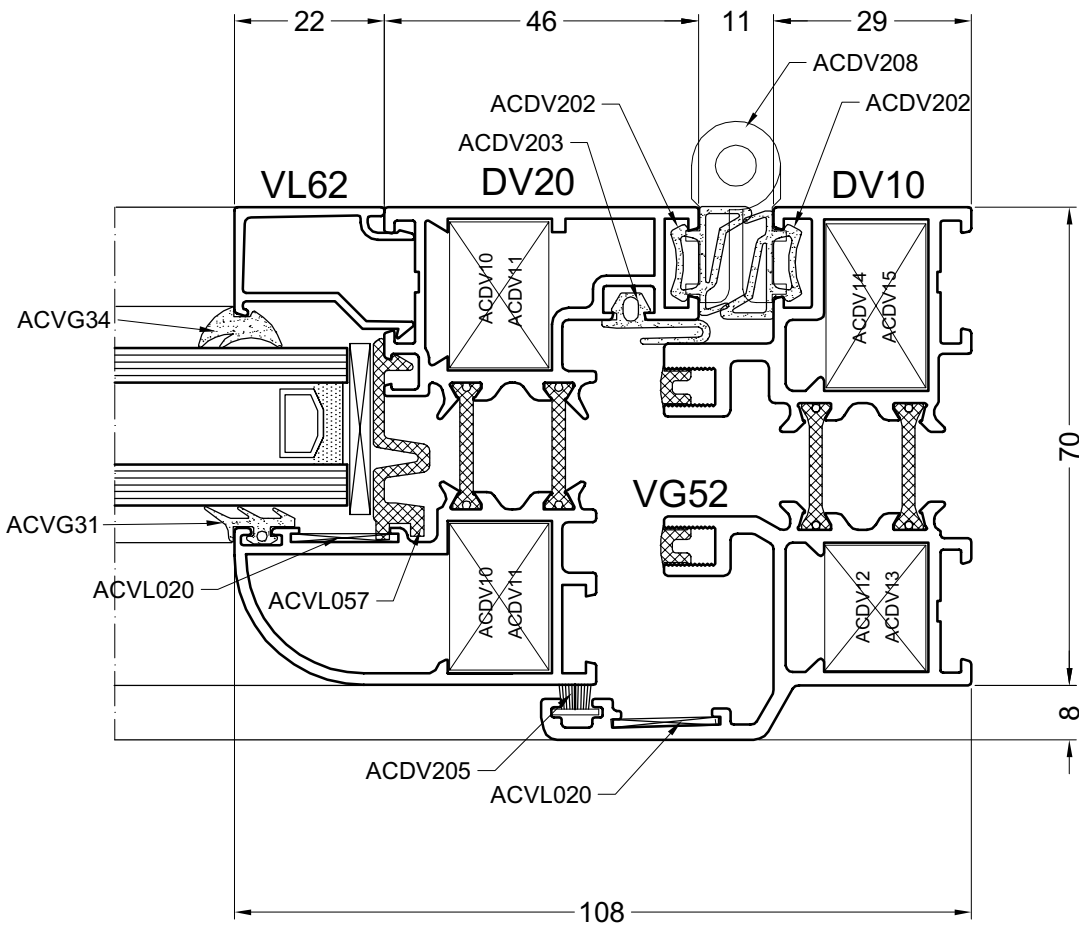
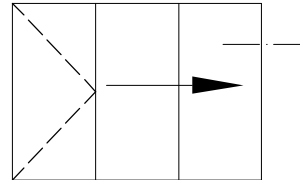

7A

DOORSNEDE - COUPE - SCHNITT - SECTION

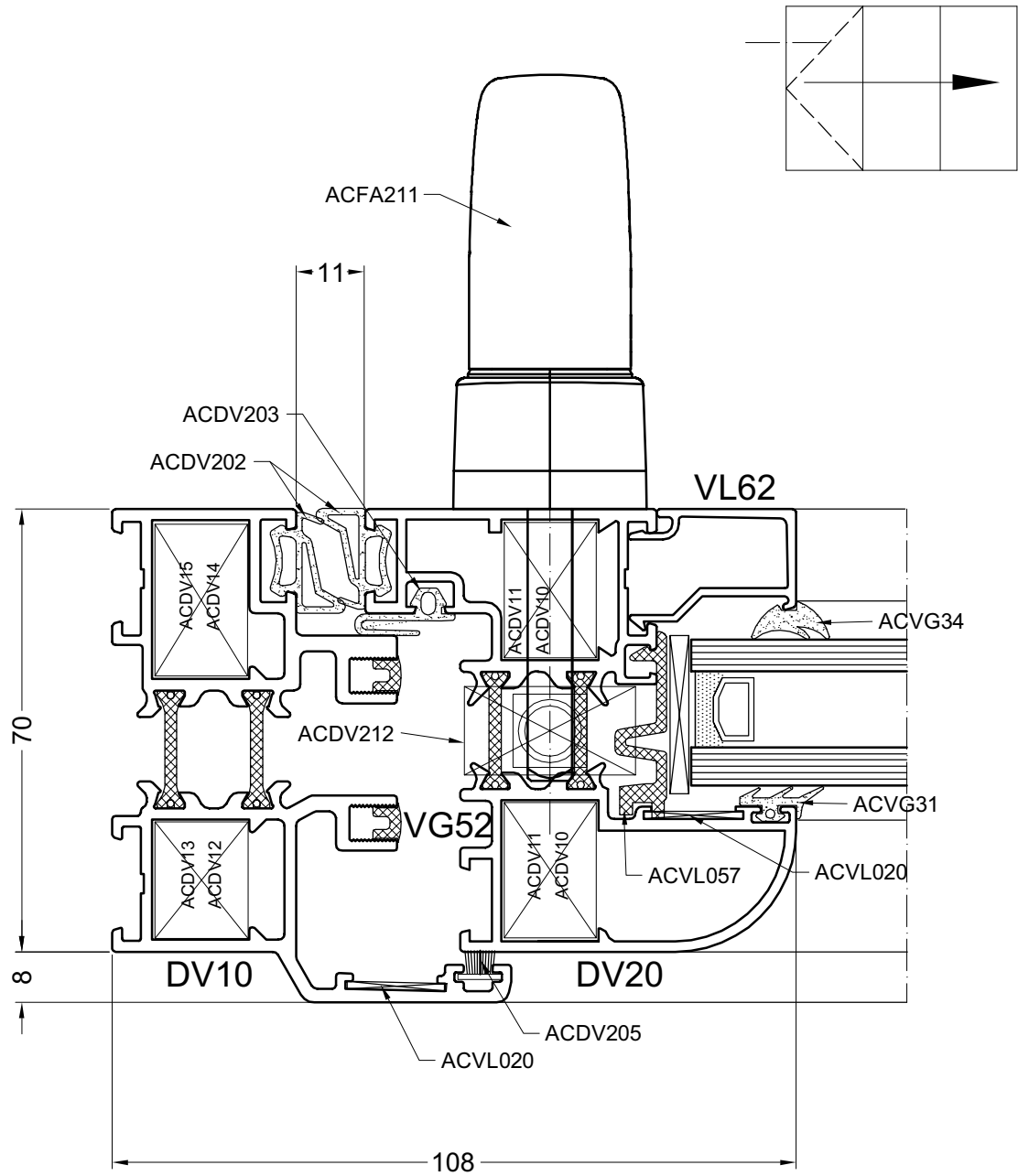

door07a

7B

DOORSNEDE - COUPE - SCHNITT - SECTION

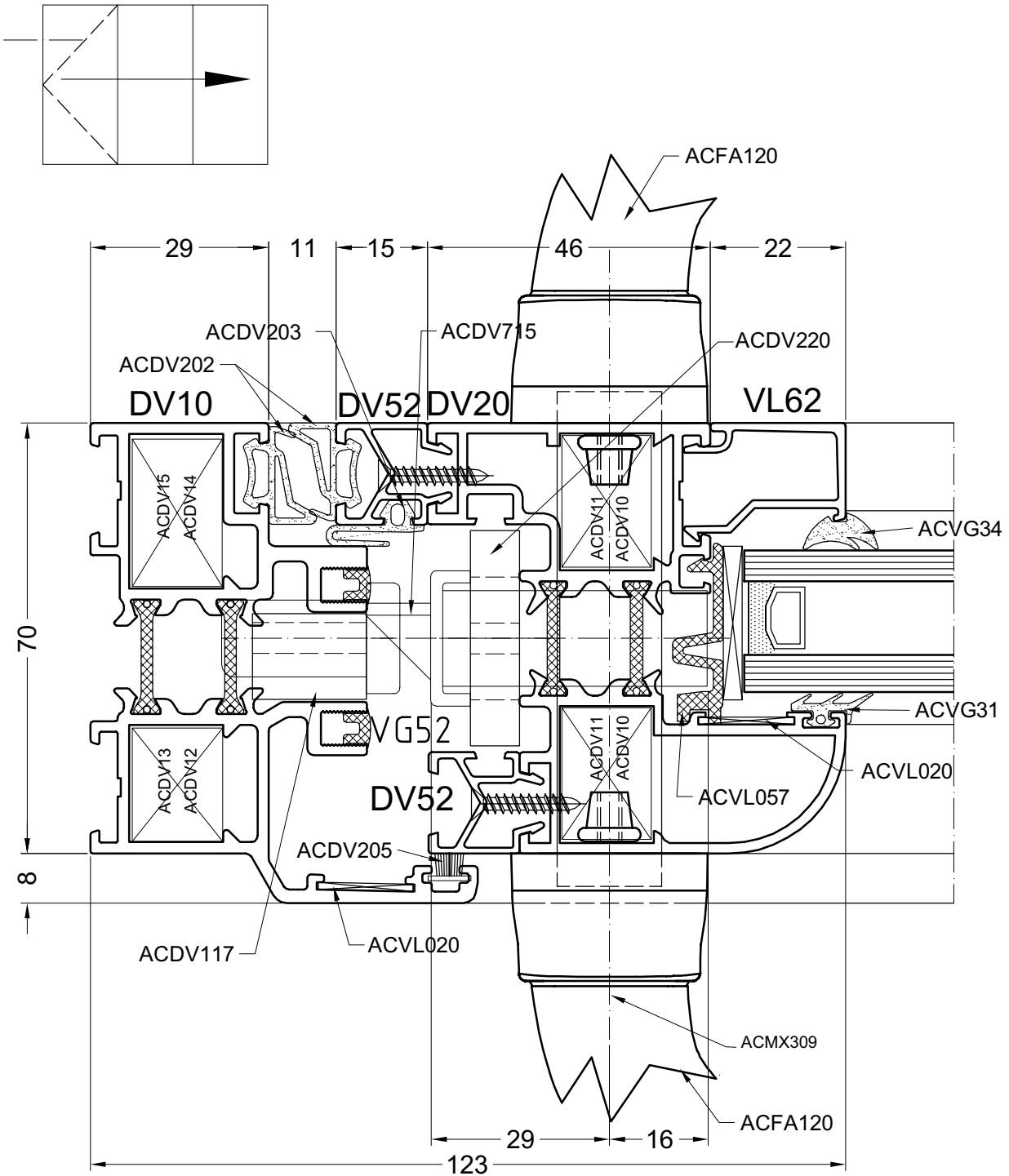

door07b

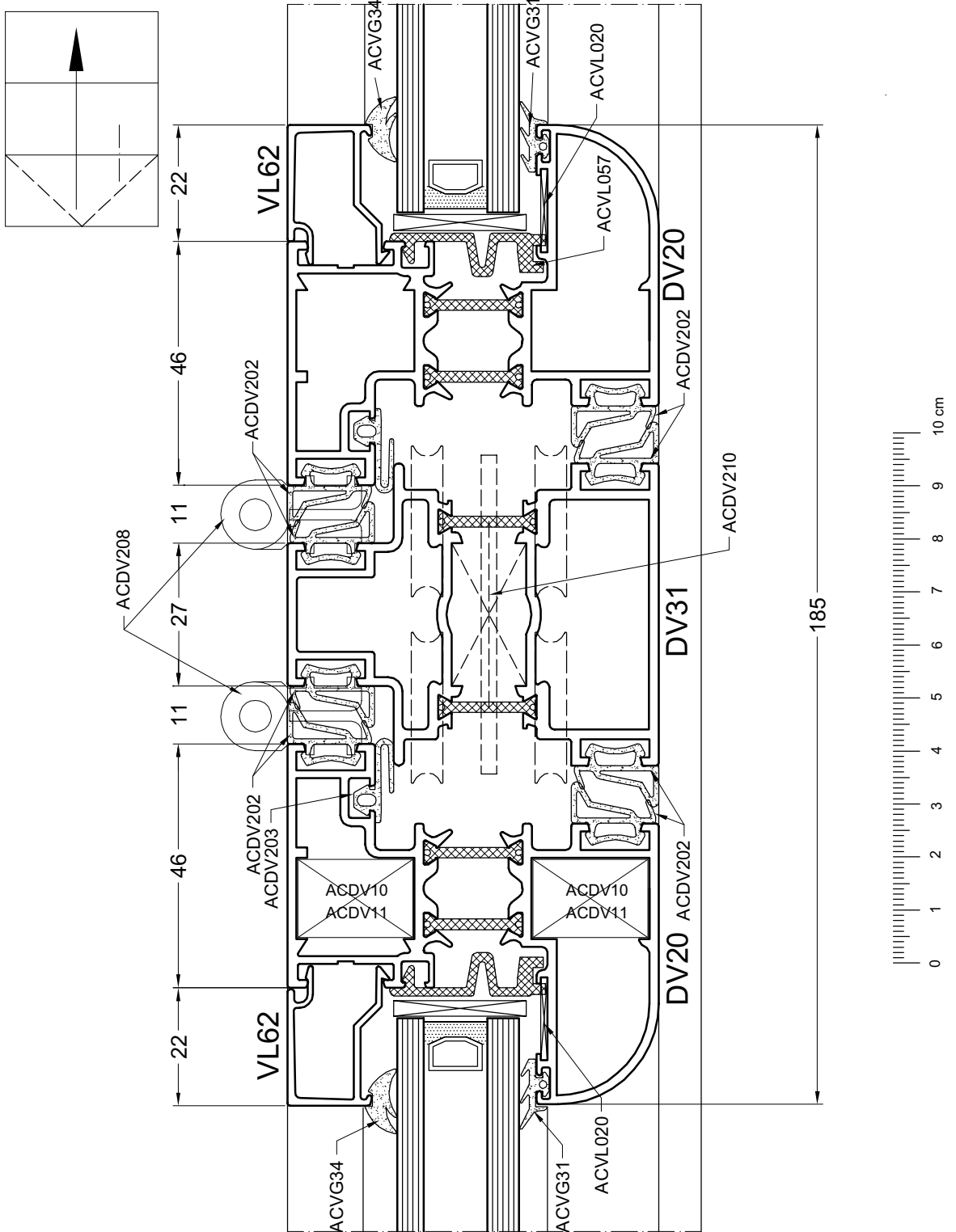

door08

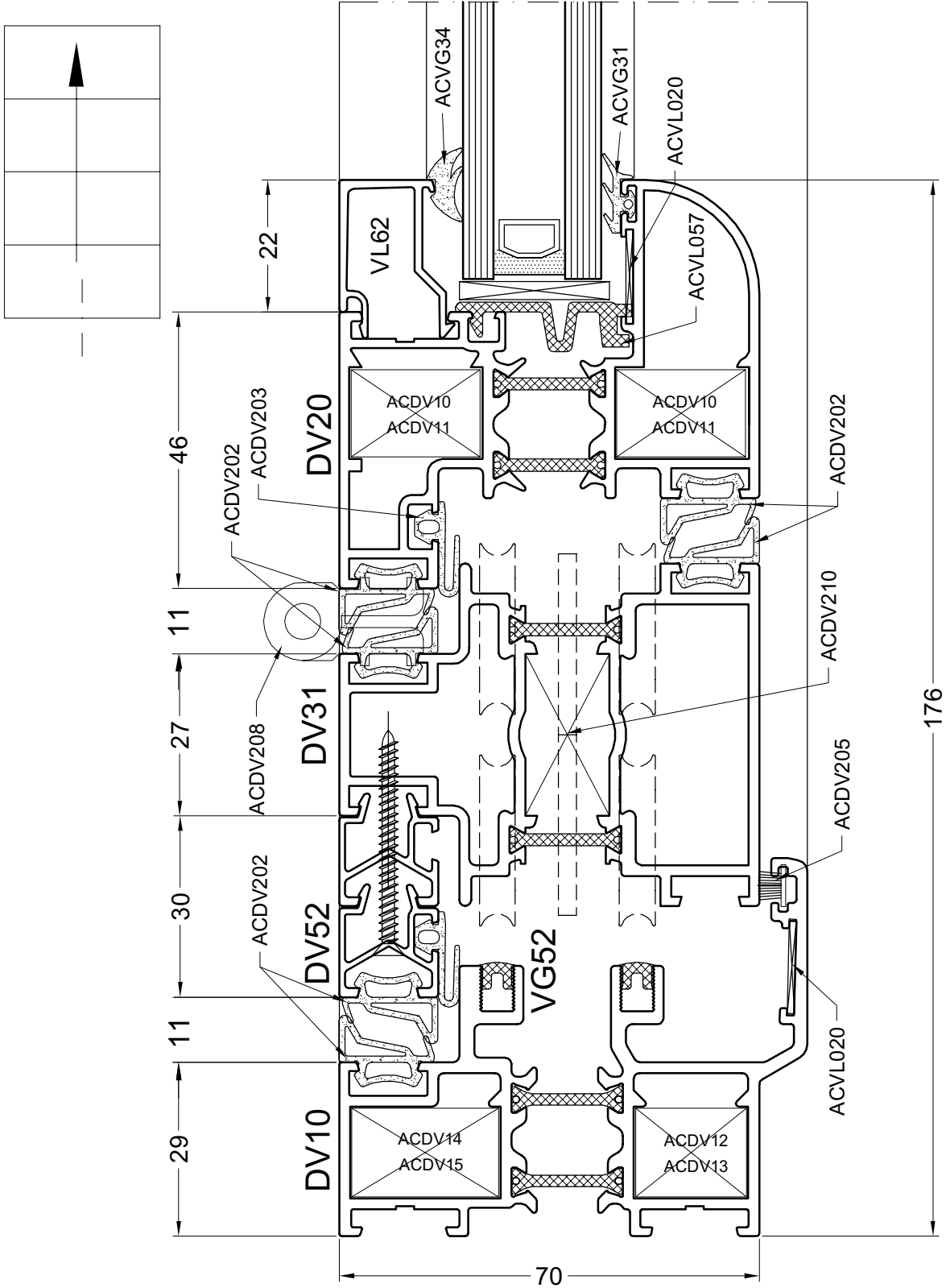

door09

10A

DOORSNEDE - COUPE - SCHNITT - SECTION

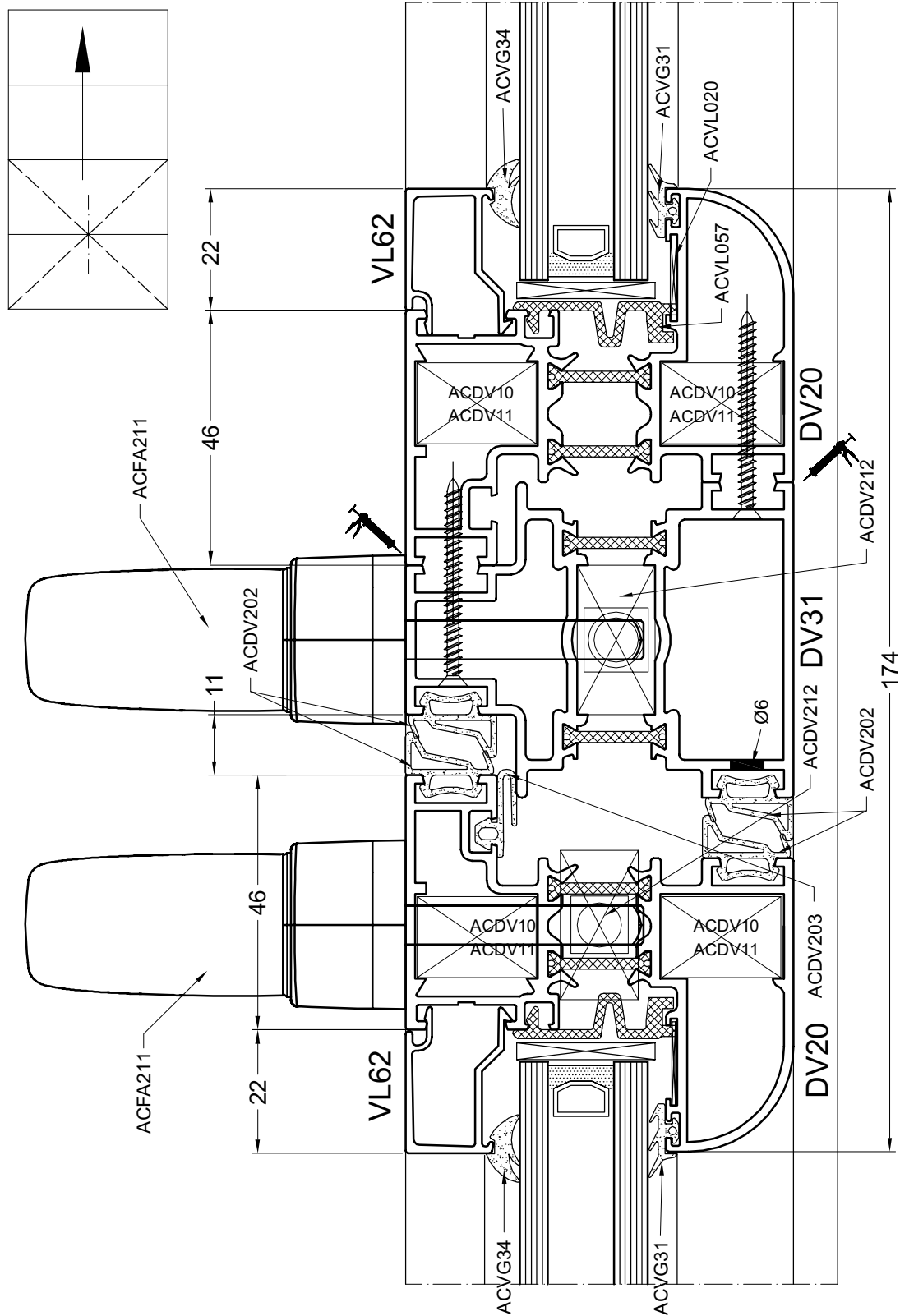

door10a

10B

DOORSNEDE - COUPE - SCHNITT - SECTION

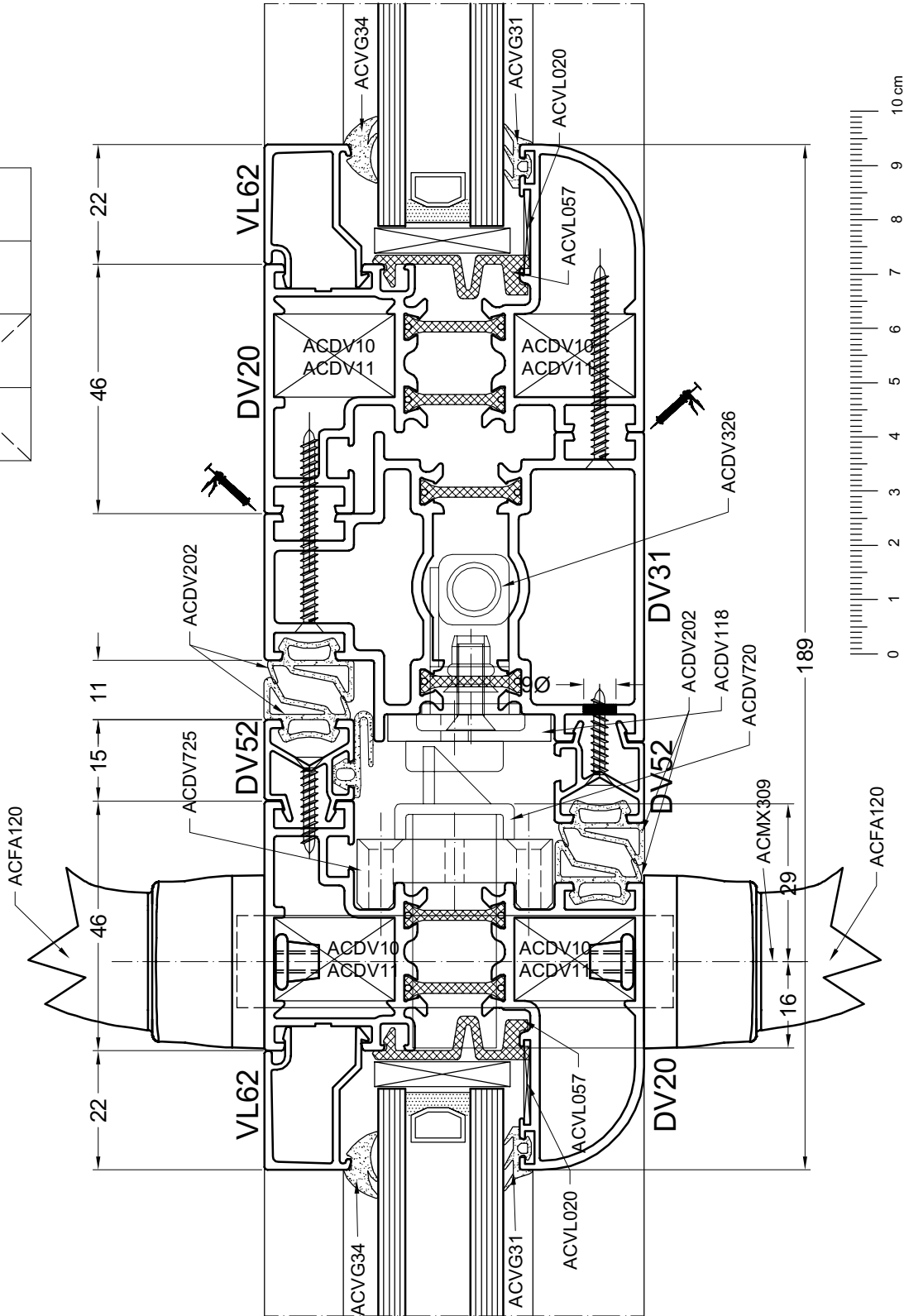
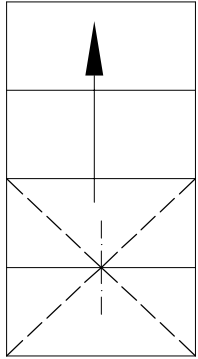

door10b

10C

DOORSNEDE - COUPE - SCHNITT - SECTION

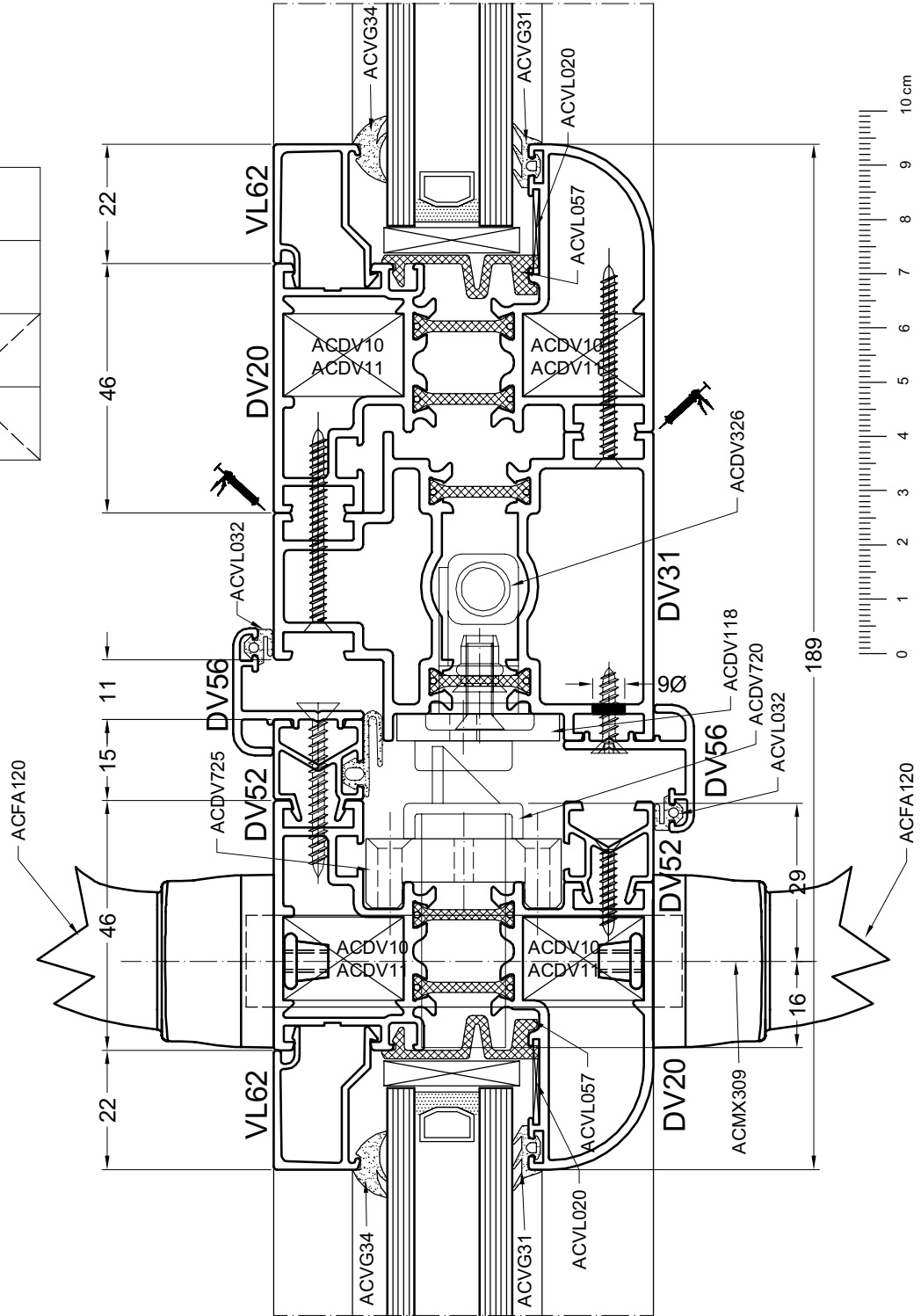
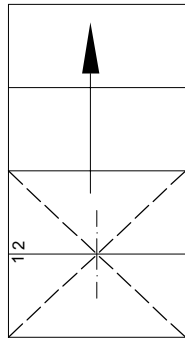

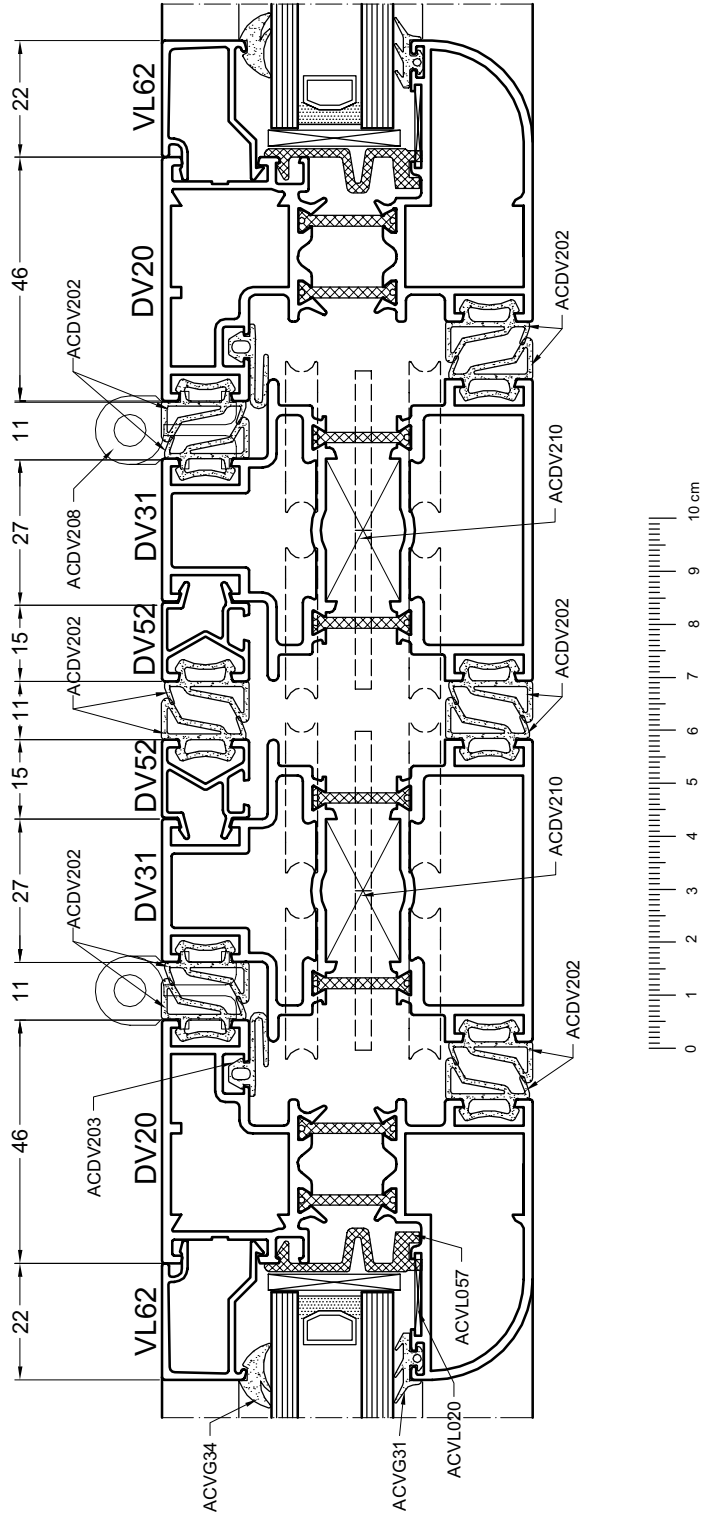
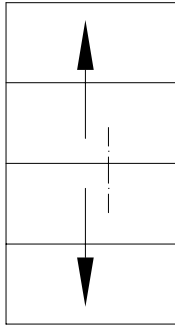

door11

VOUWDEUR NAAR BUITEN OPENEND
PORTES AMOVIBLES OUVRANT EXTERIEUR
FALT TUREN NACH AUSSEN OFFNEND
FOLDING DOORS OUTWARDS OPENING

DOORSNEDE - COUPE - SCHNITT - SECTION

Type 1e

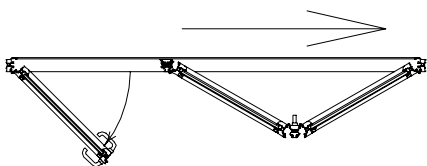
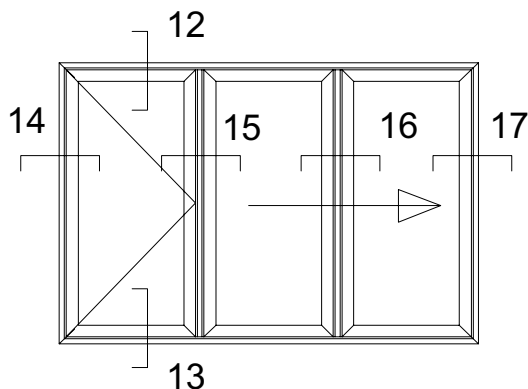

Type 2e

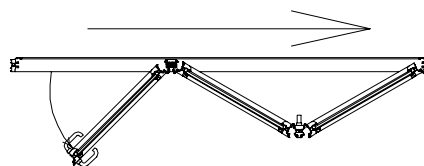
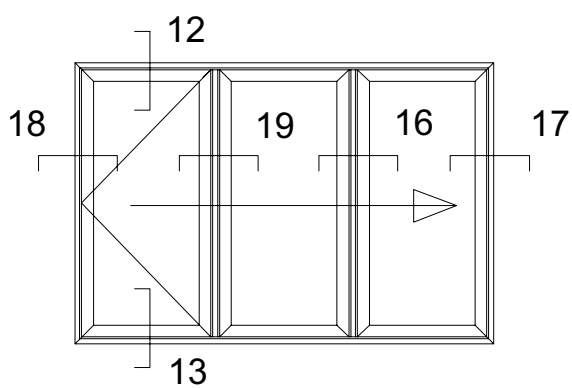

Type 3e

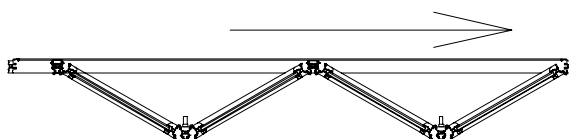
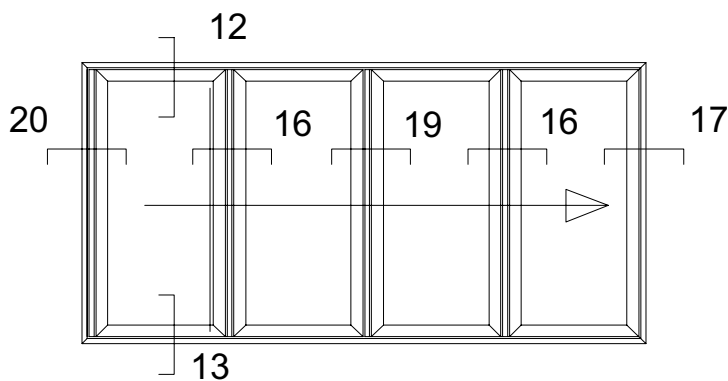

DOORTYP4

VOUWDEUR NAAR BUITEN OPENEND
PORTES AMOVIBLES OUVRANT EXTERIEUR
FALT TUREN NACH AUSSEN OFFNEND
FOLDING DOORS OUTWARDS OPENING

DOORSNEDE - COUPE - SCHNITT - SECTION

Type 4e

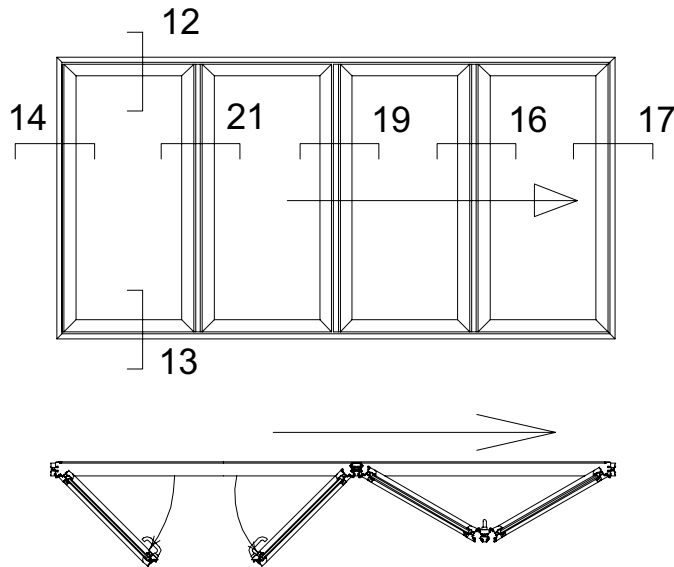

Type 5e

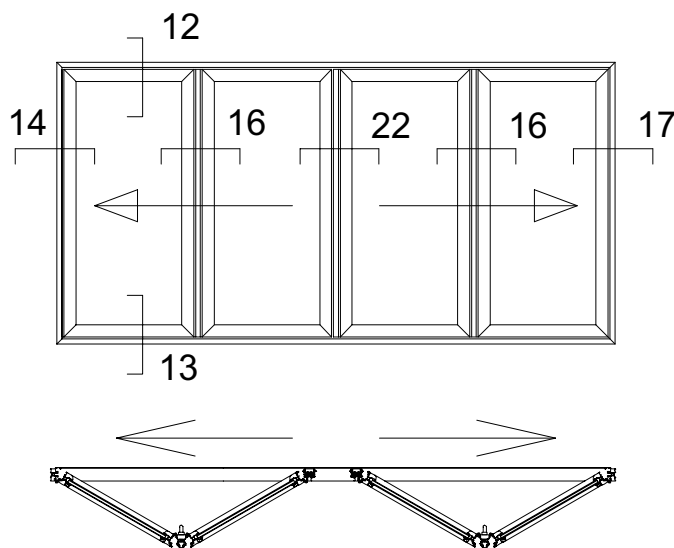

DOORTYP5

VOUWDEUR NAAR BUITEN OPENEND
PORTES AMOVIBLES OUVRANT EXTERIEUR
FALT TUREN NACH AUSSEN OFFNEND
FOLDING DOORS OUTWARDS OPENING

DOORSNEDE - COUPE - SCHNITT - SECTION

Type 6e

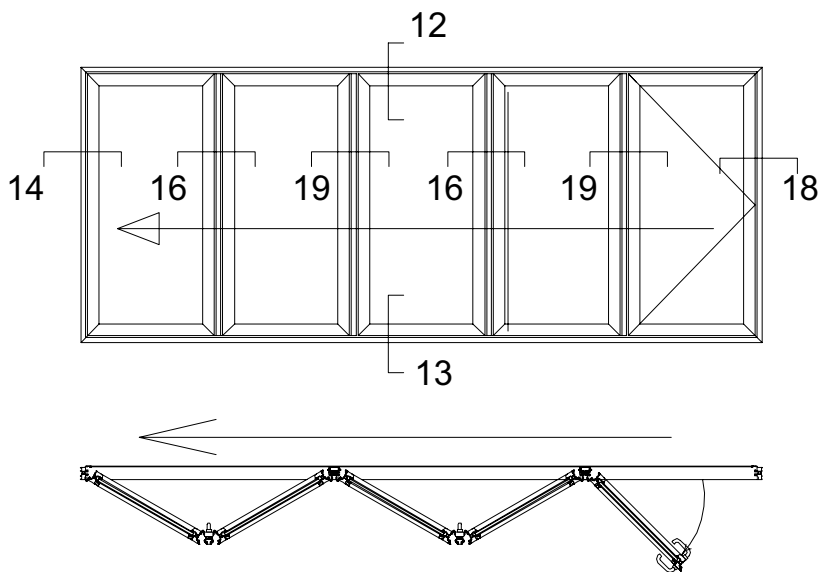

Type 7e

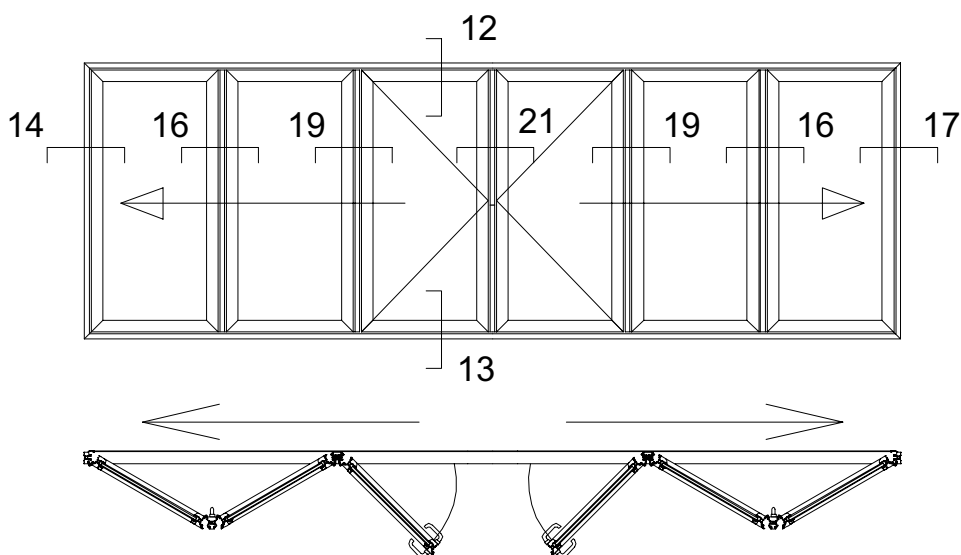

DOORTYP6

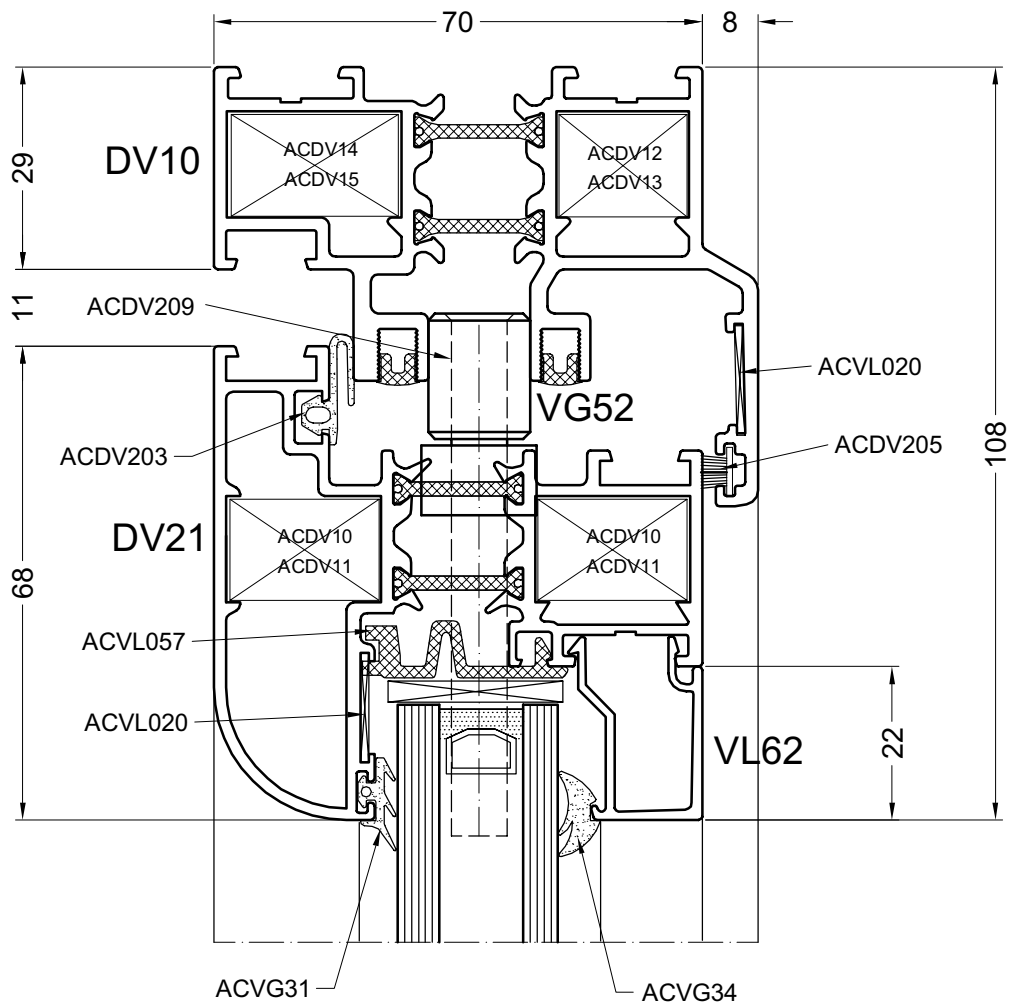
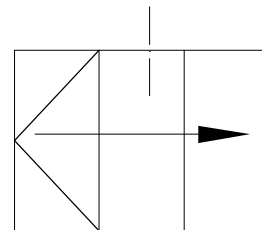

13A

DOORSNEDE - COUPE - SCHNITT - SECTION

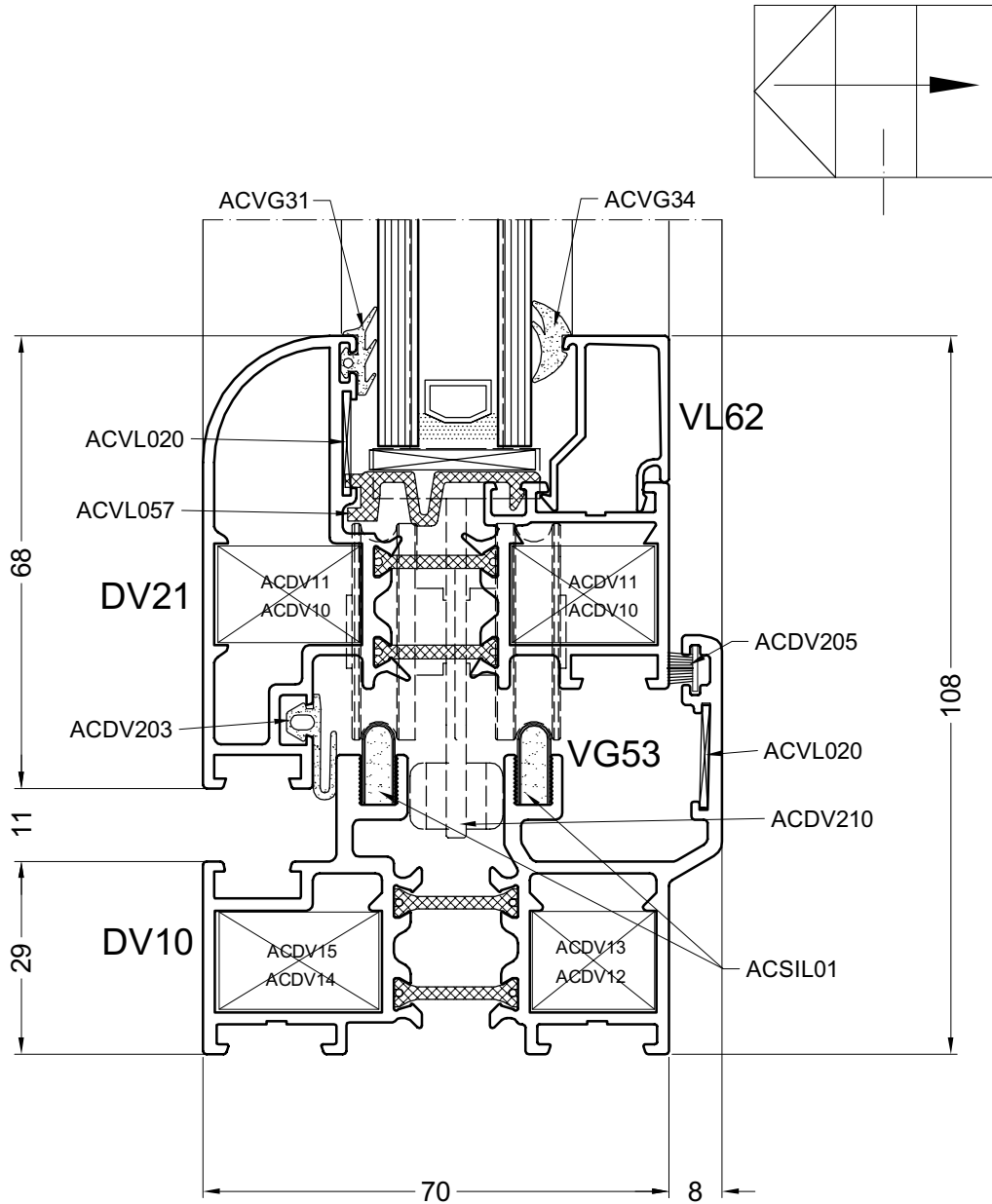

door13a

13B

DOORSNEDE - COUPE - SCHNITT - SECTION

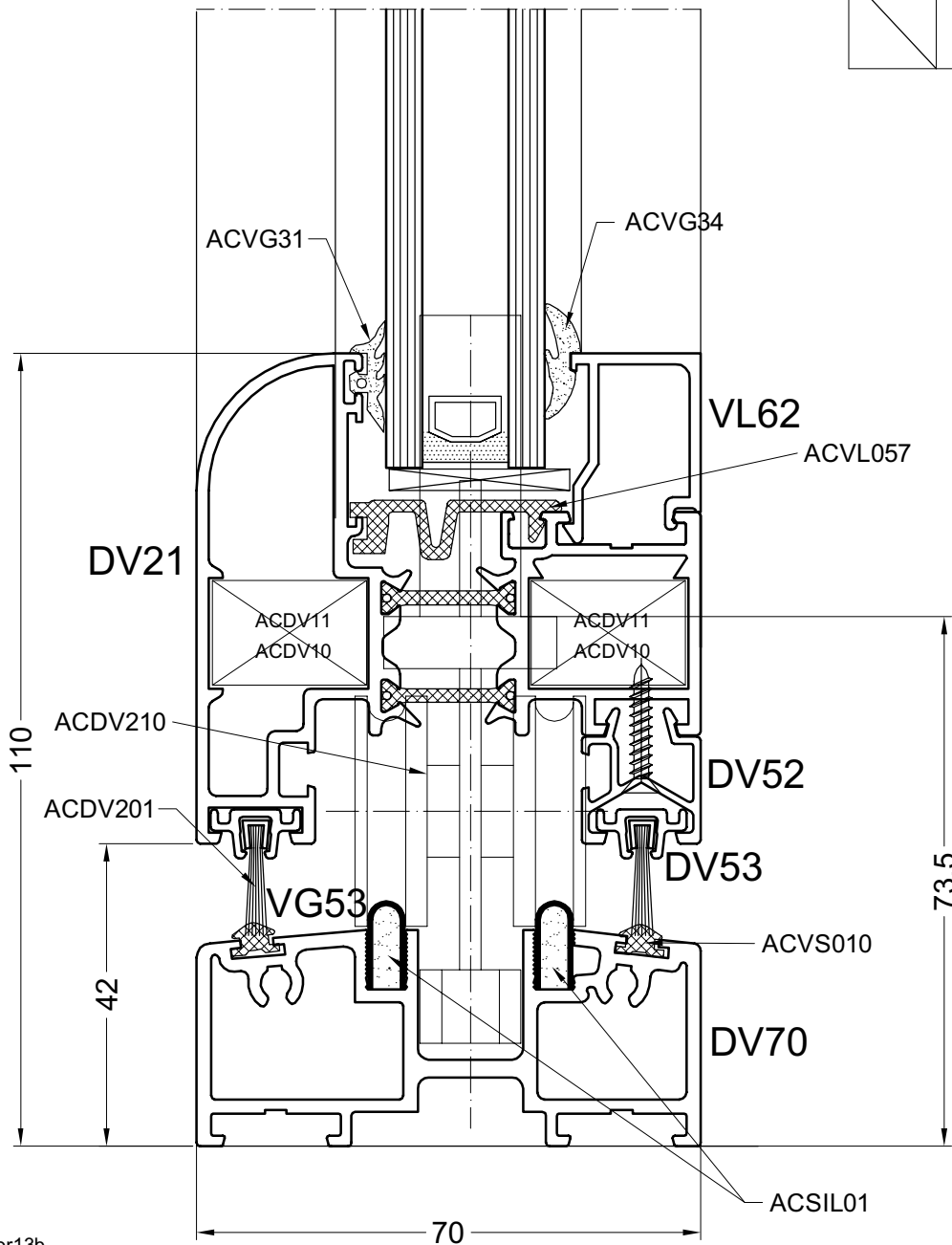
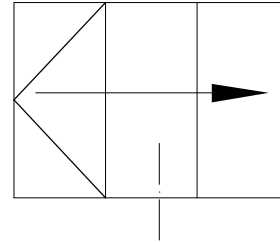

door13b

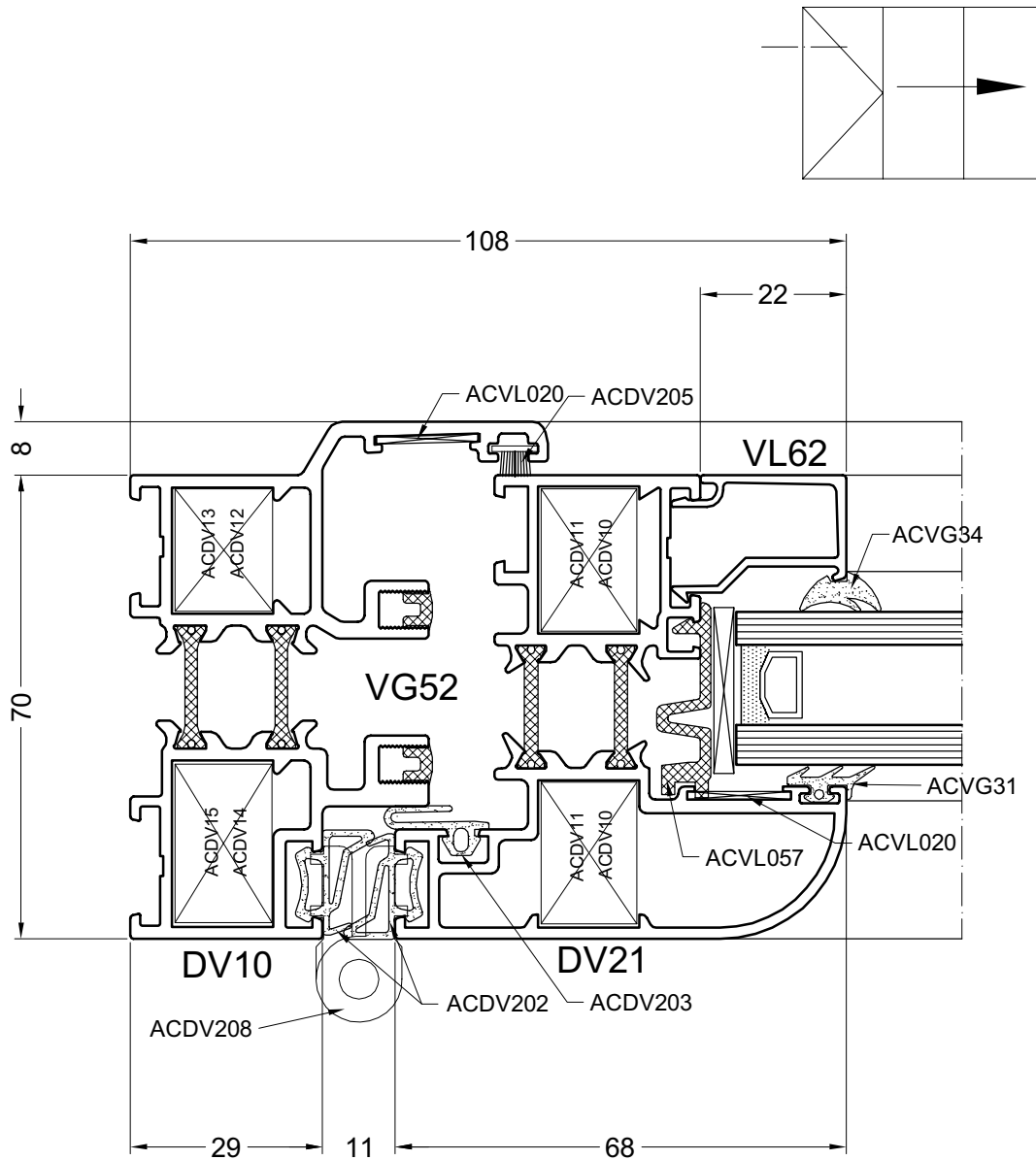

15A

DOORSNEDE - COUPE - SCHNITT - SECTION

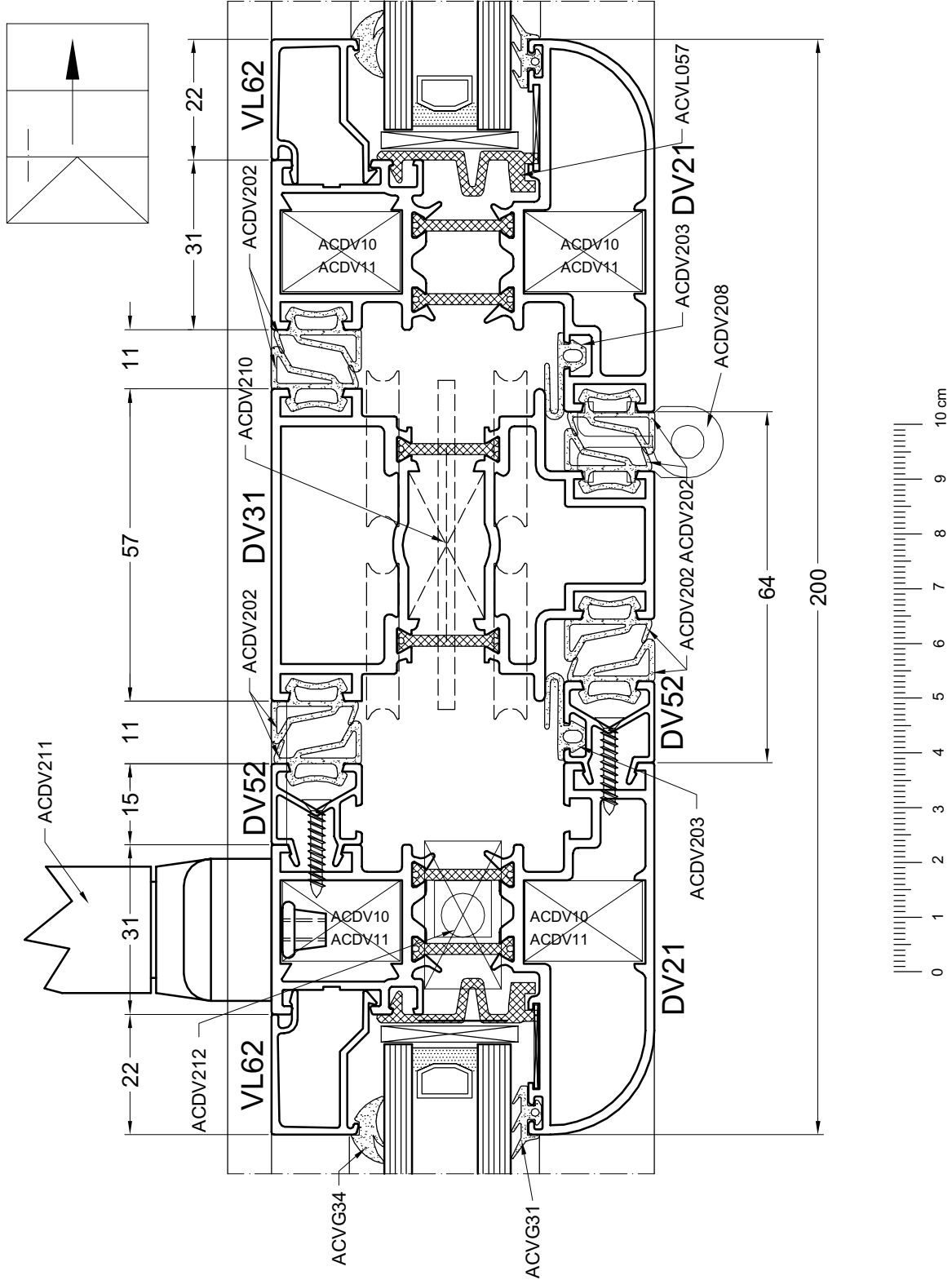

door15a

15B

DOORSNEDE - COUPE - SCHNITT - SECTION

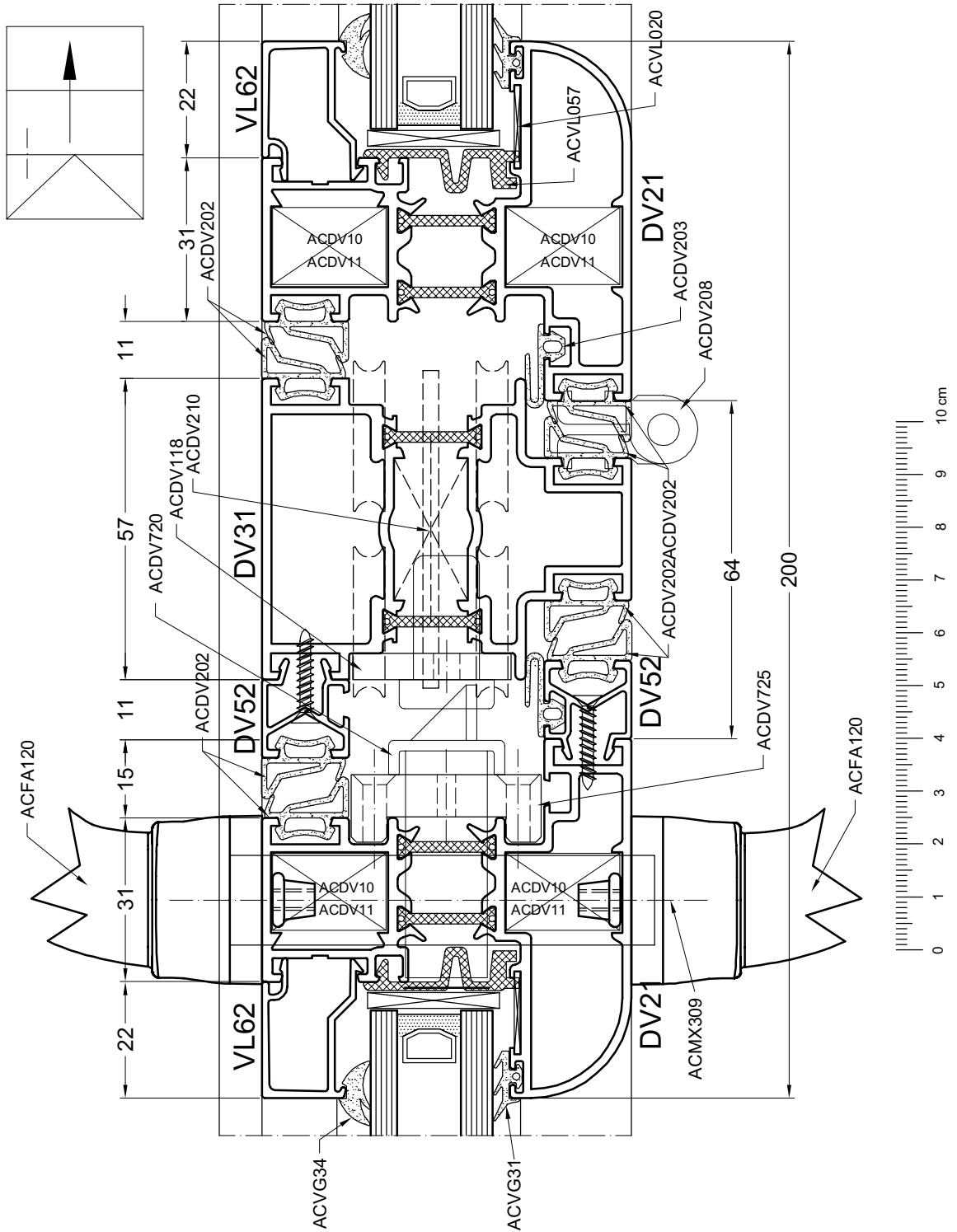

door15b

15C

DOORSNEDE - COUPE - SCHNITT - SECTION

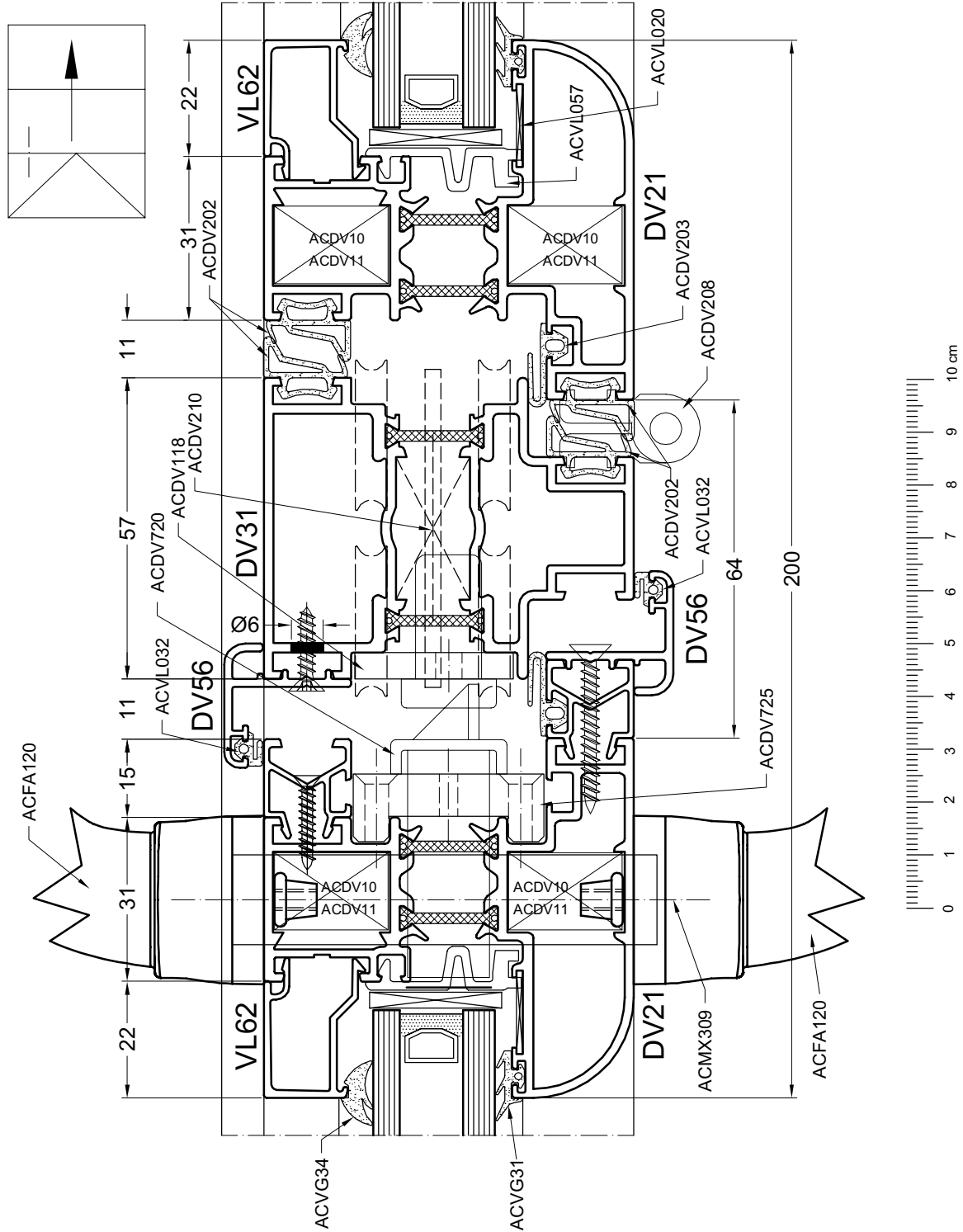

door15c

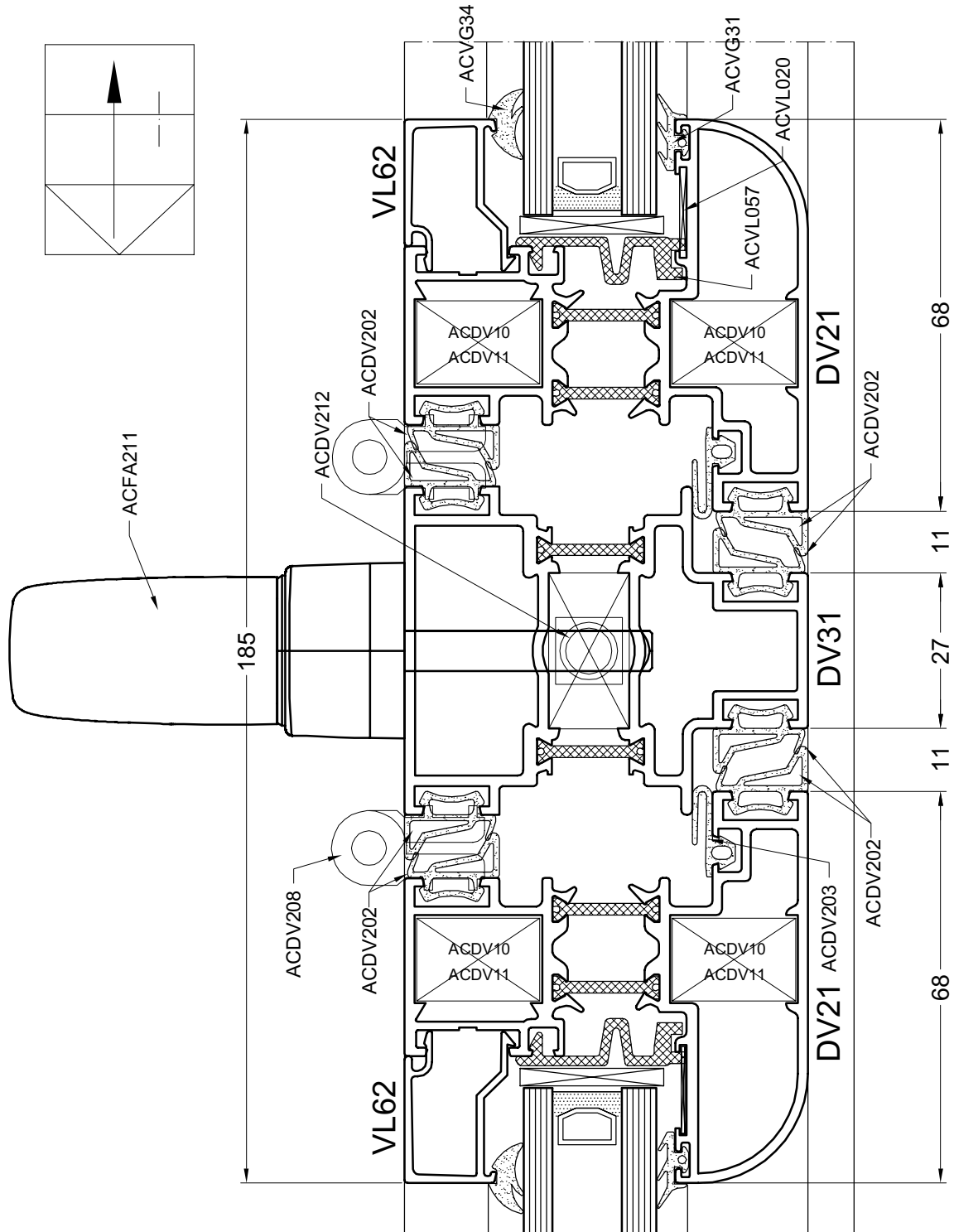

door16

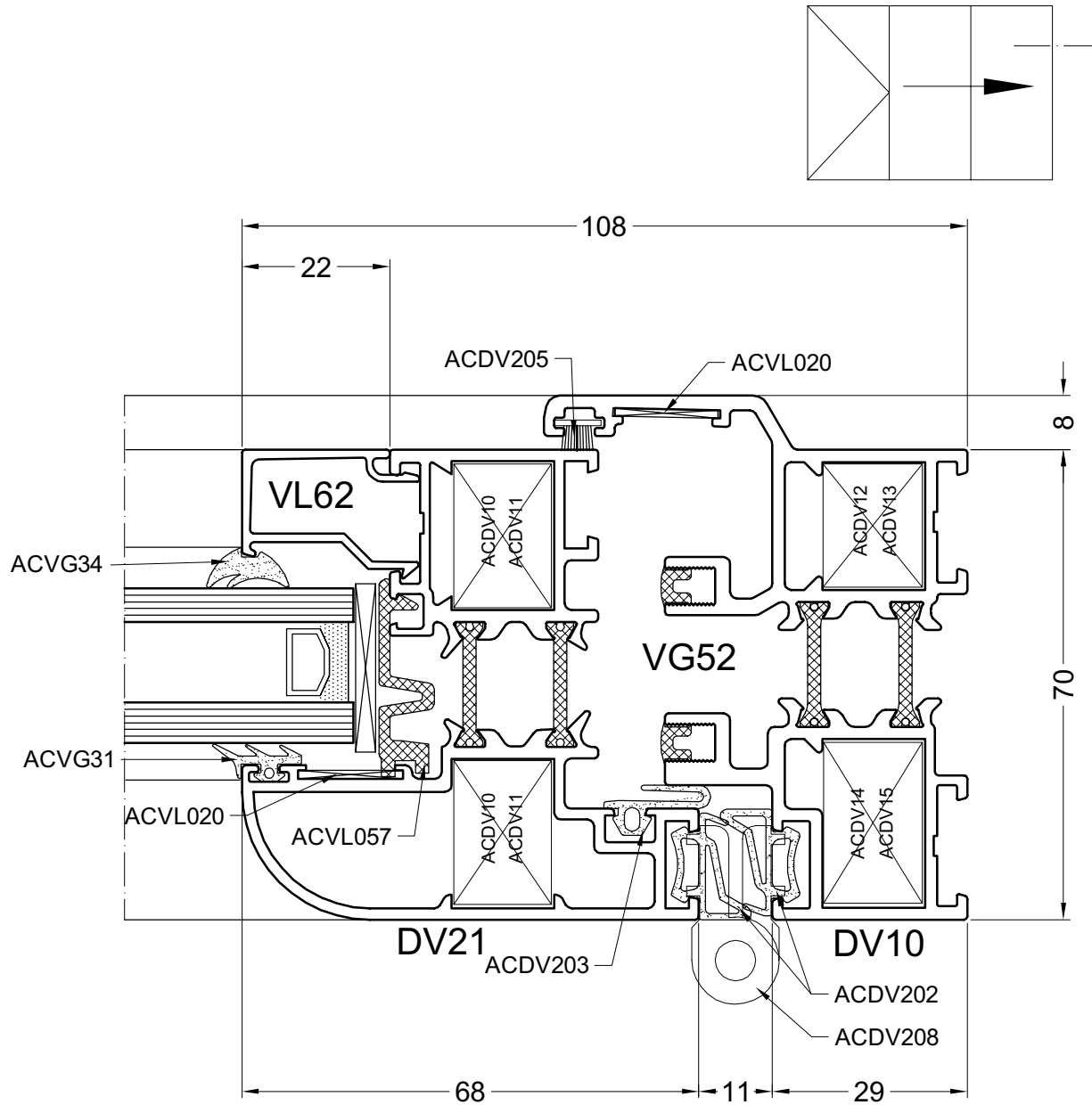

door17

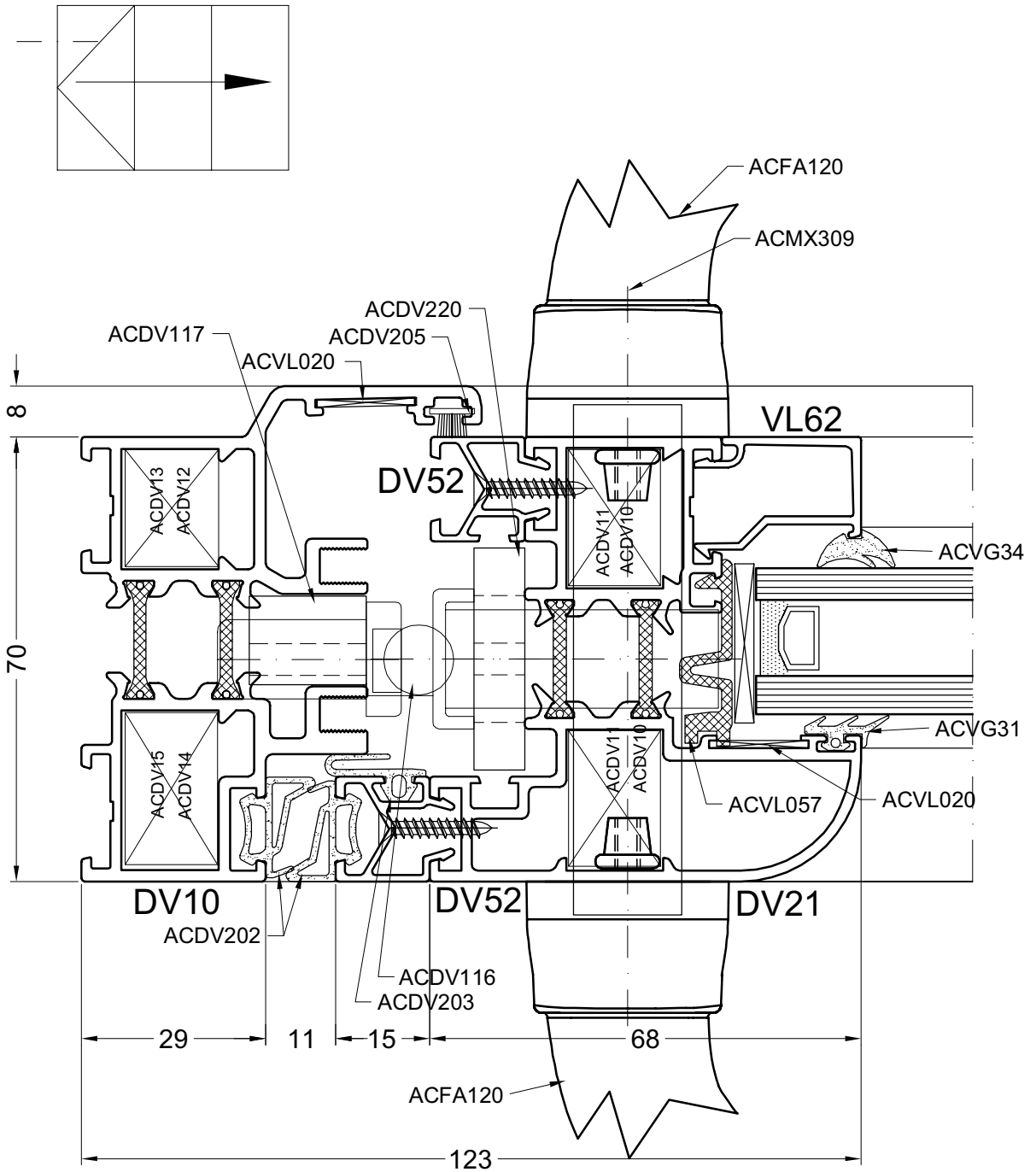

door18b

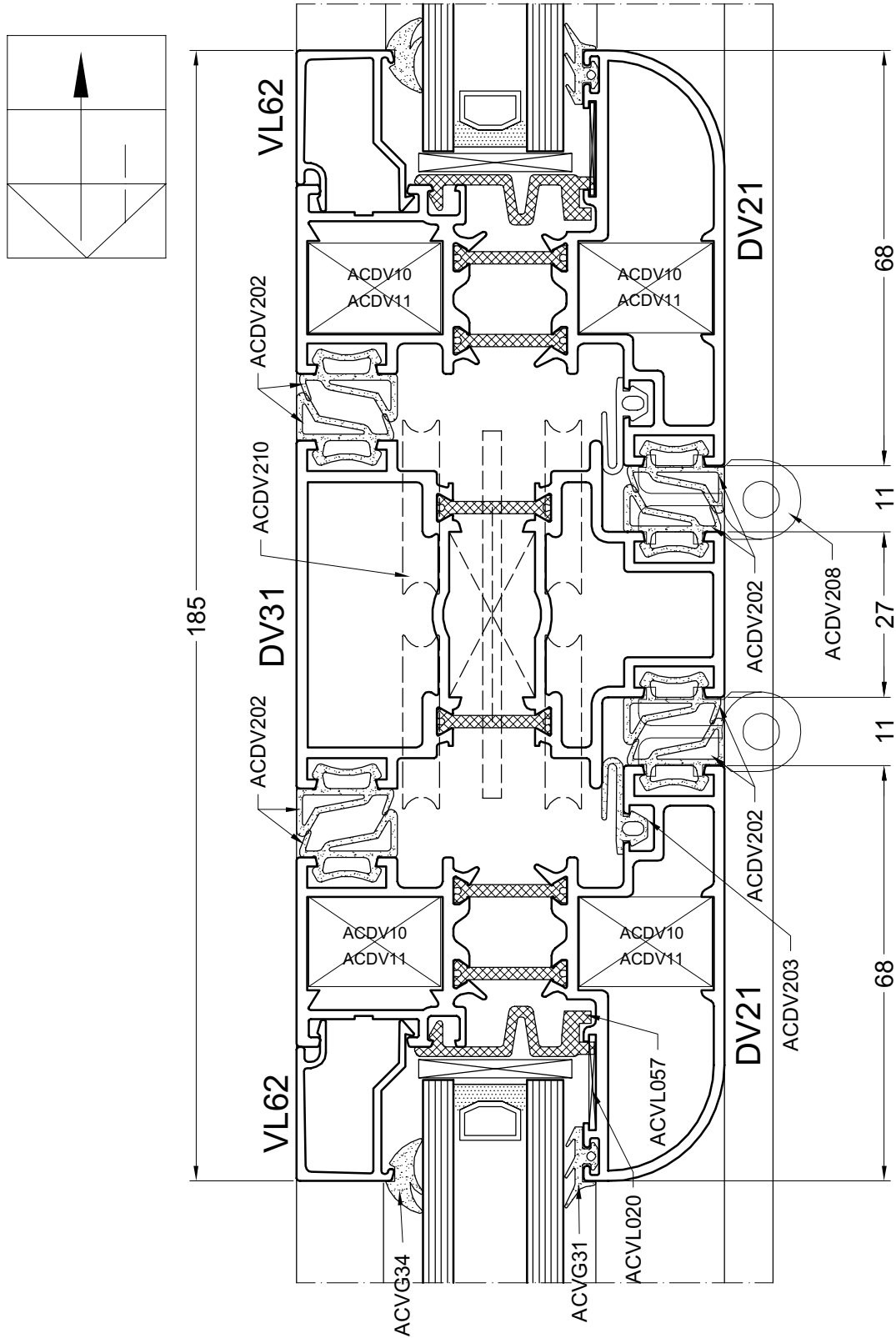

door.19

20

DOORSNEDE - COUPE - SCHNITT - SECTION

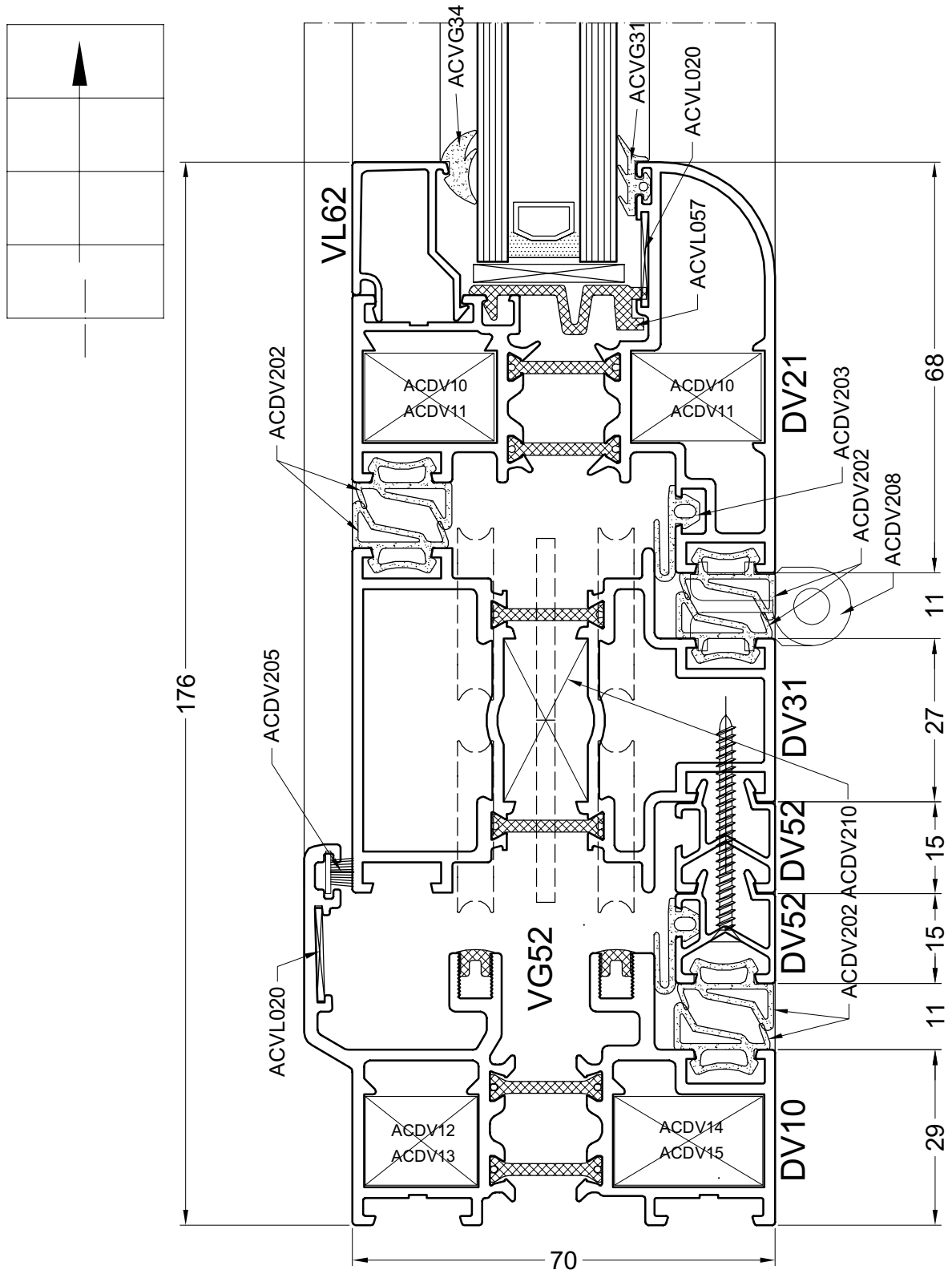

door20

21A

DOORSNEDE - COUPE - SCHNITT - SECTION

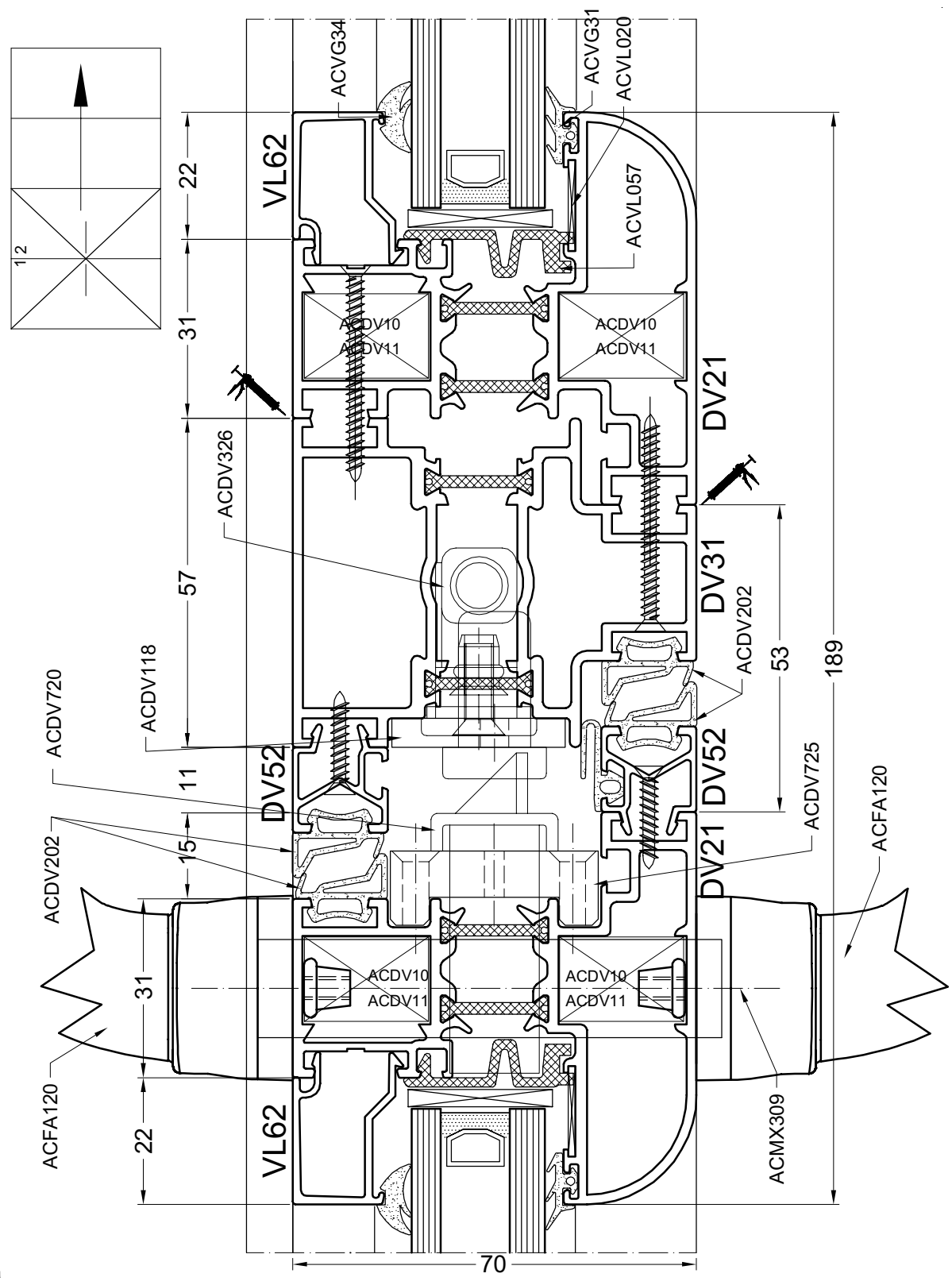

door21a

21B

DOORSNEDE - COUPE - SCHNITT - SECTION

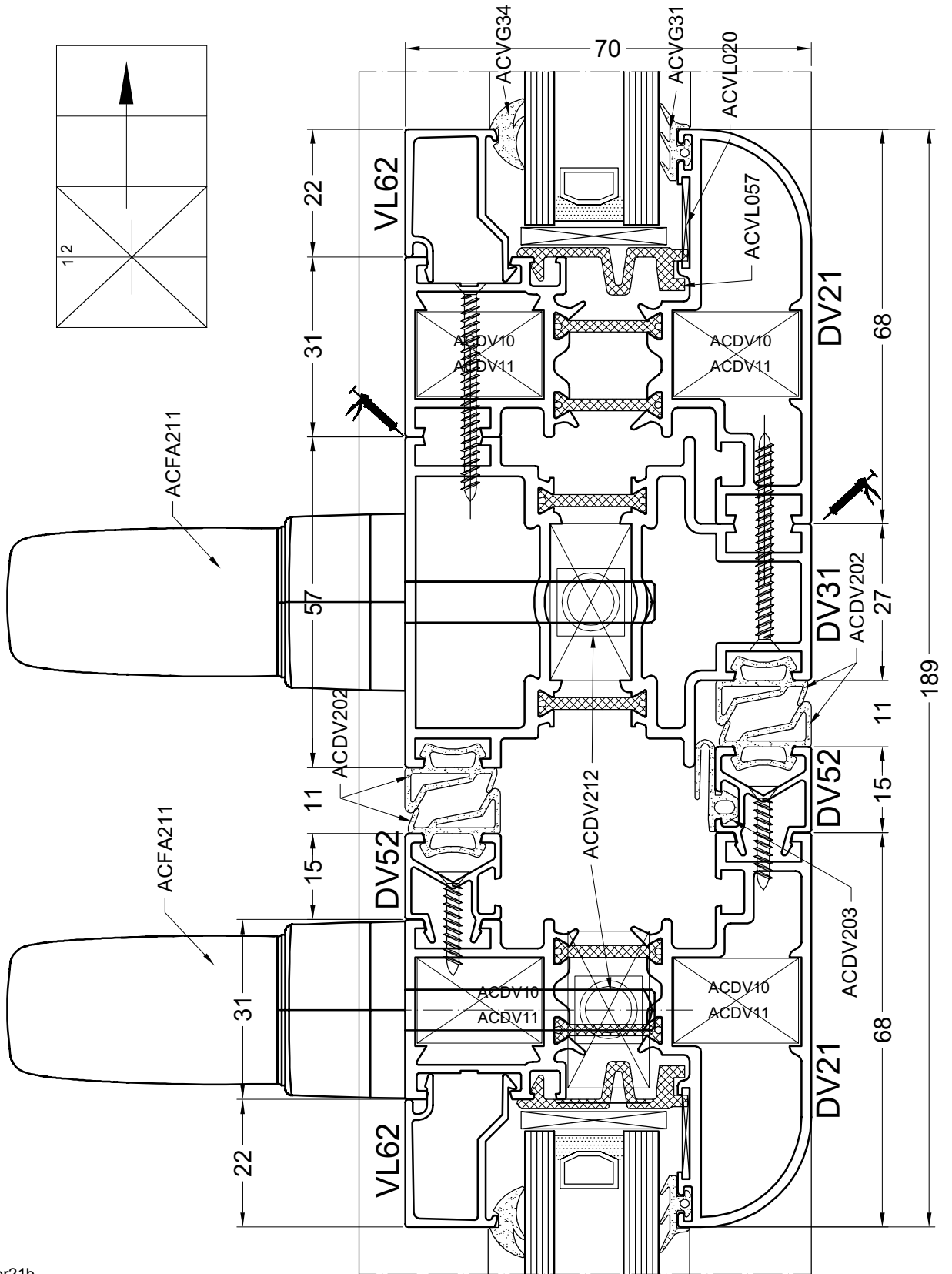

door21b

21C

DOORSNEDE - COUPE - SCHNITT - SECTION

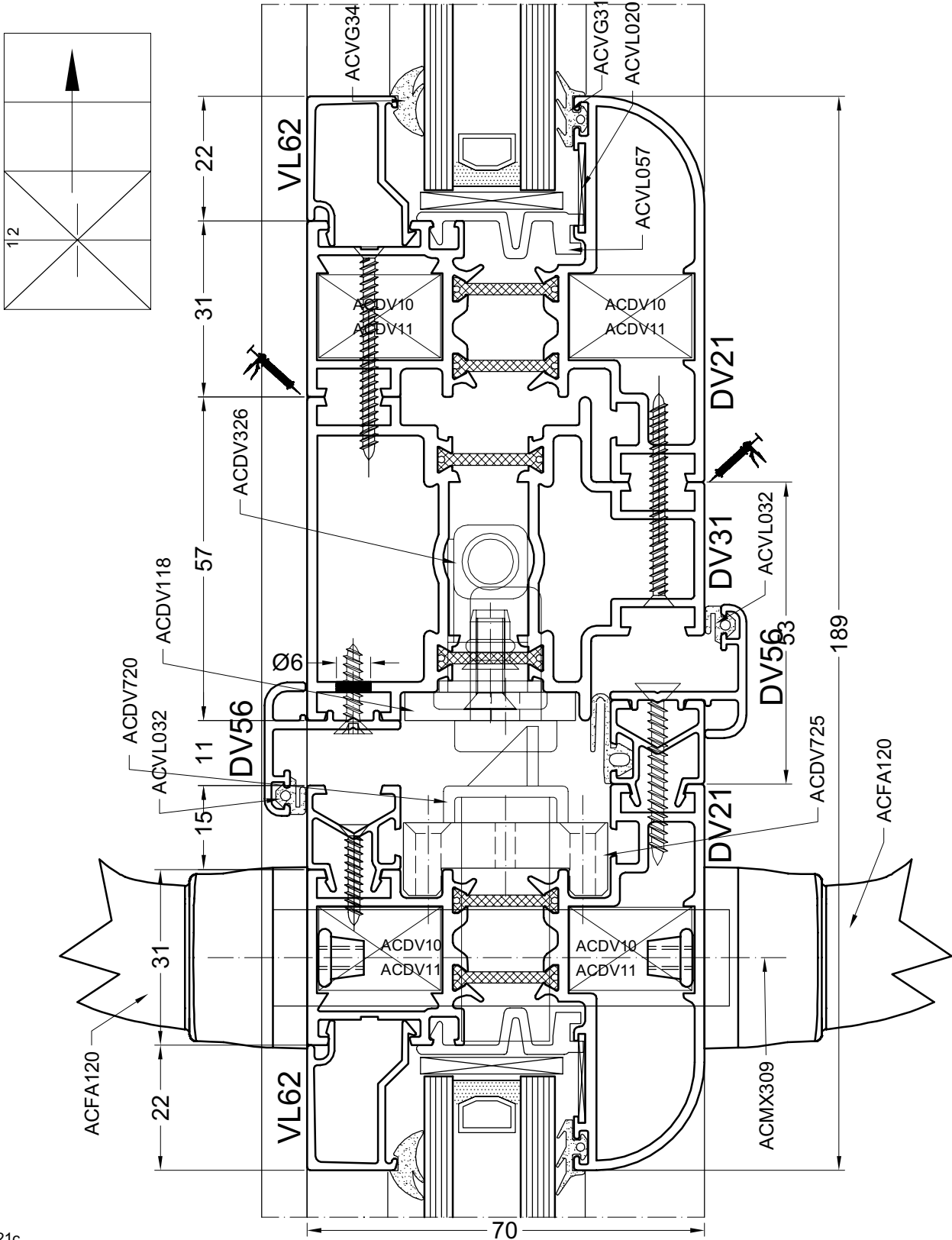

door21c

22

DOORSNEDE - COUPE - SCHNITT - SECTION

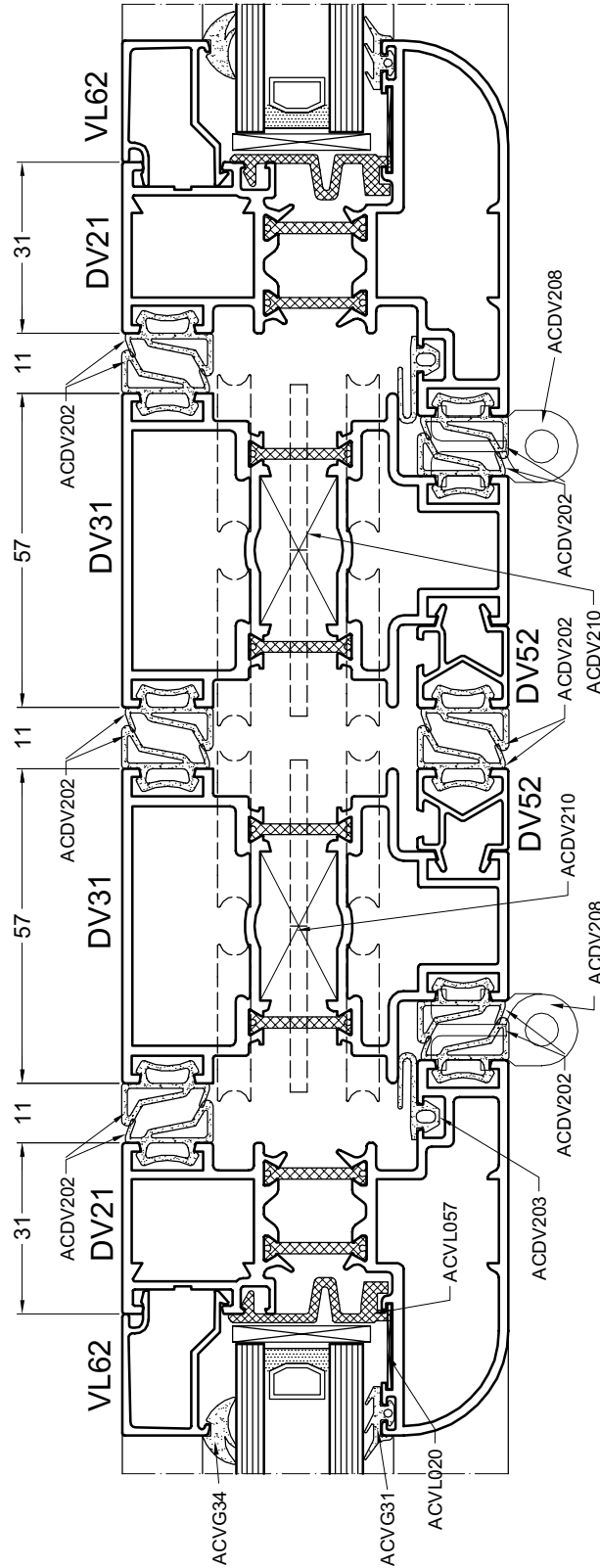
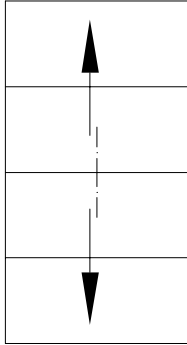

door22

RAMEN
FENETRES
RAHMEN
WINDOWS

DOORSNEDE - COUPE - SCHNITT - SECTION

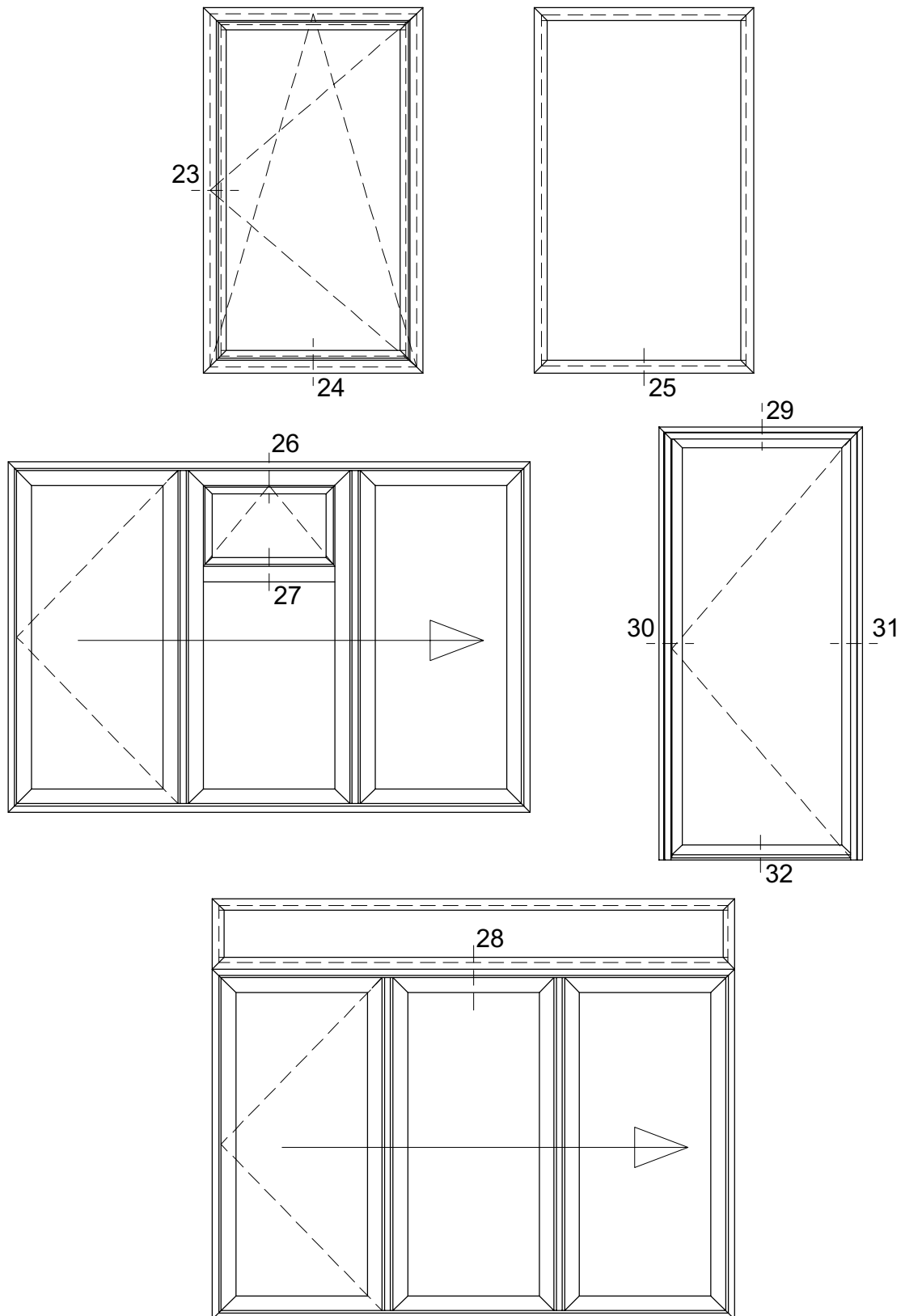

doortyp7

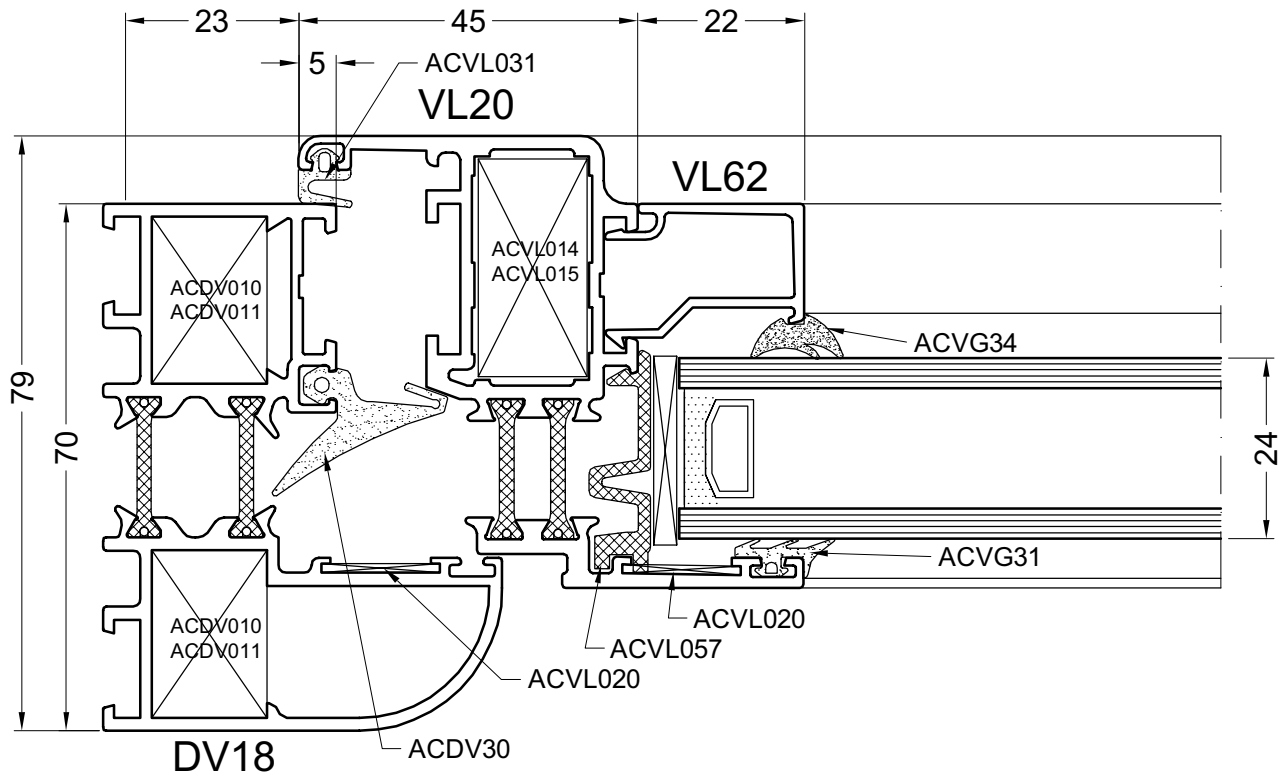
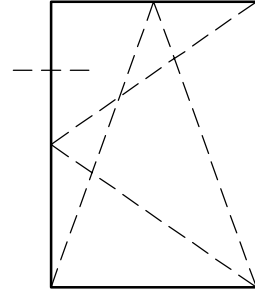

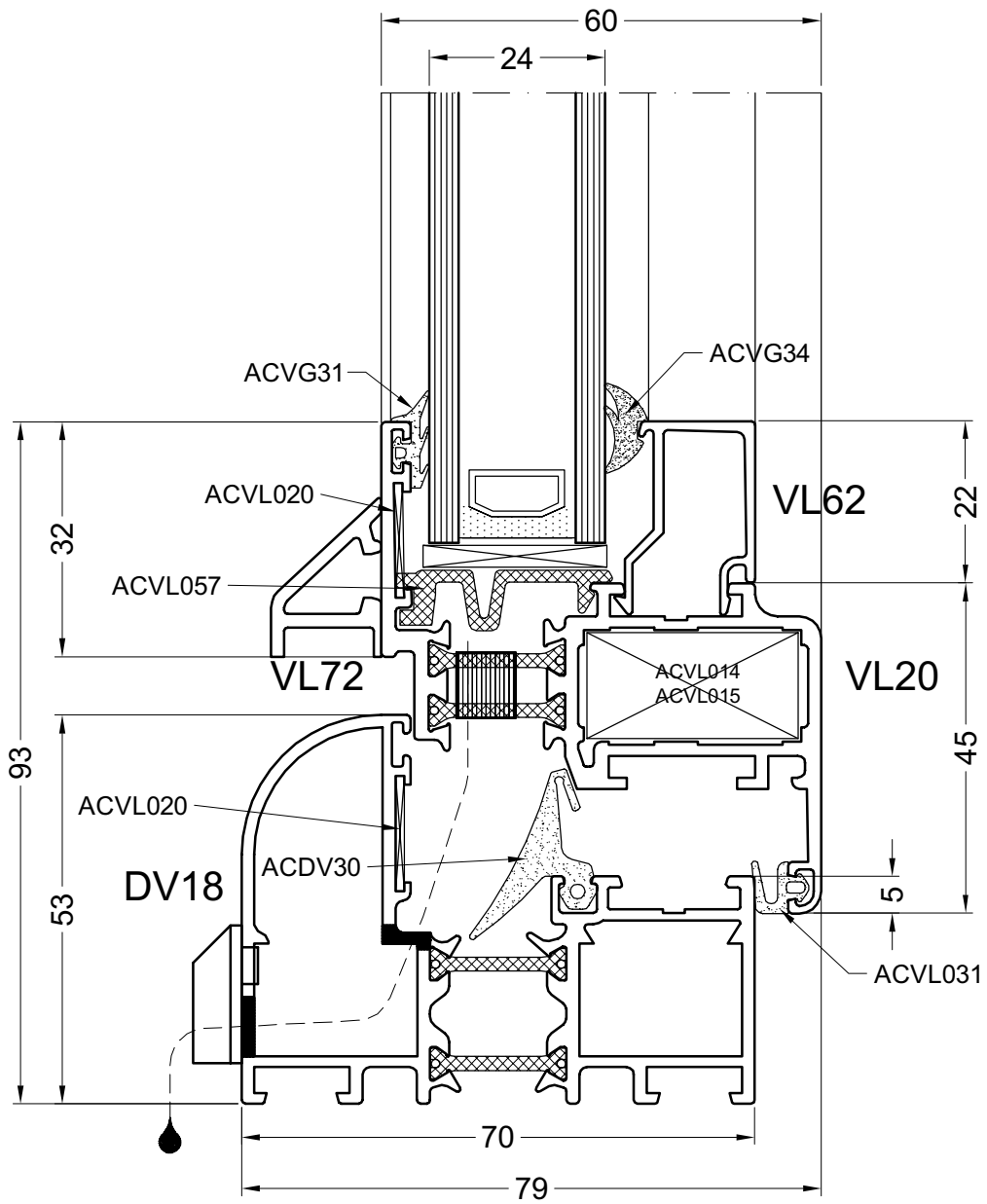
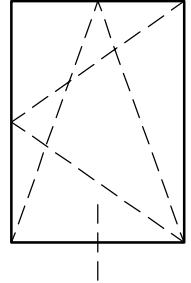

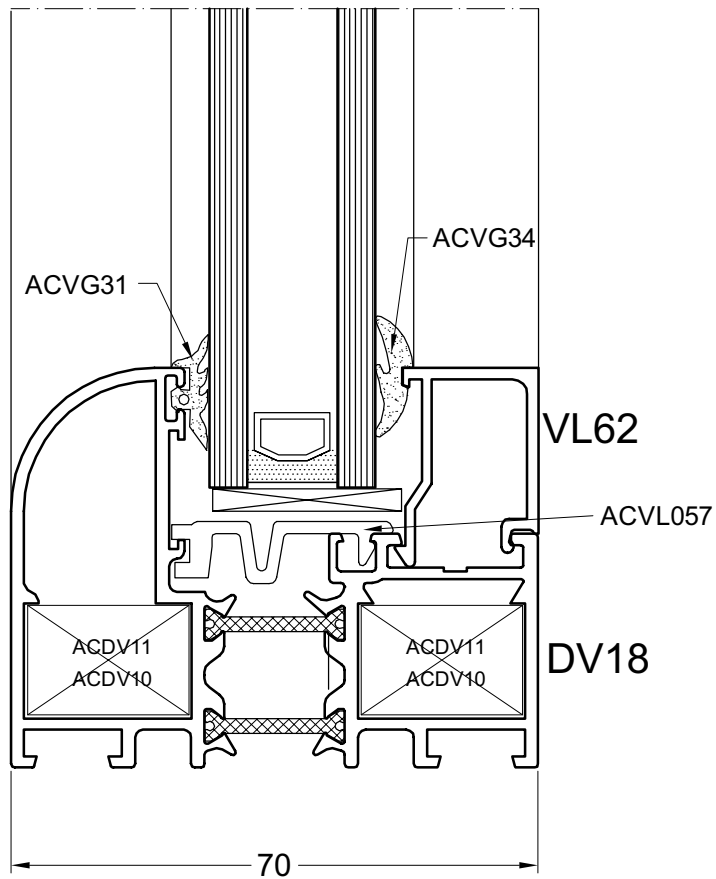
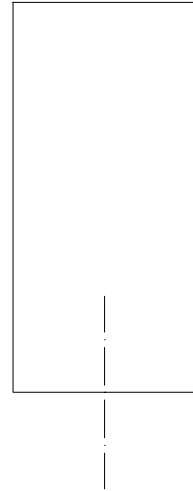

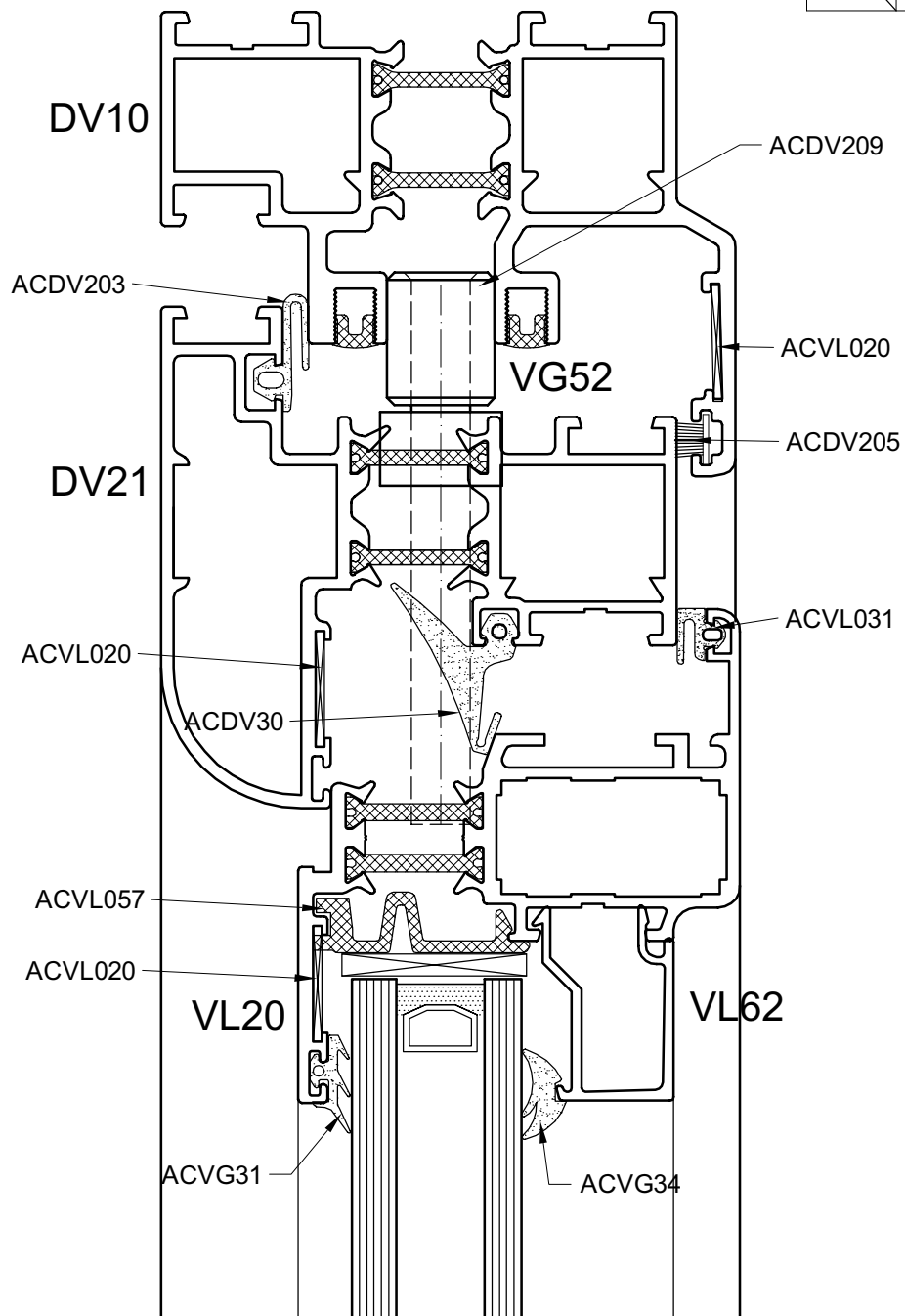
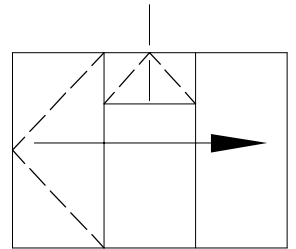

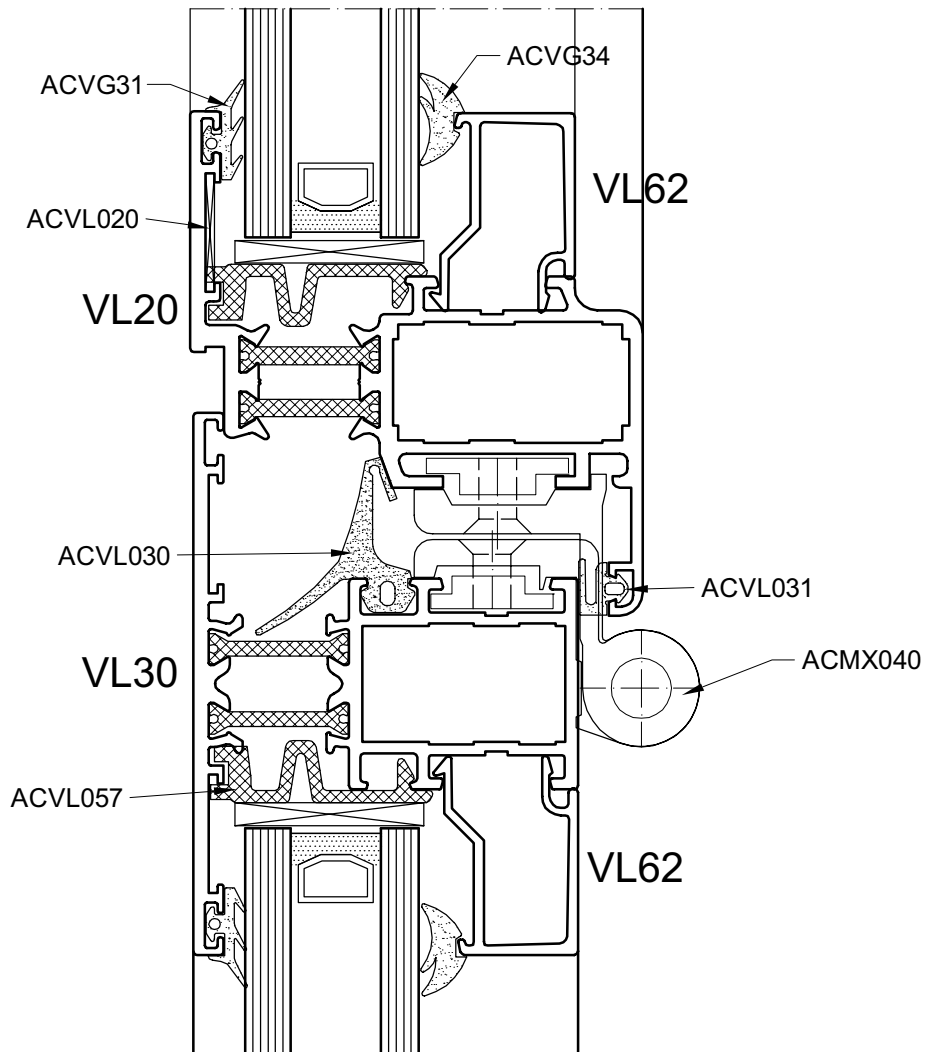
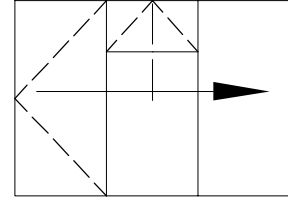

door27

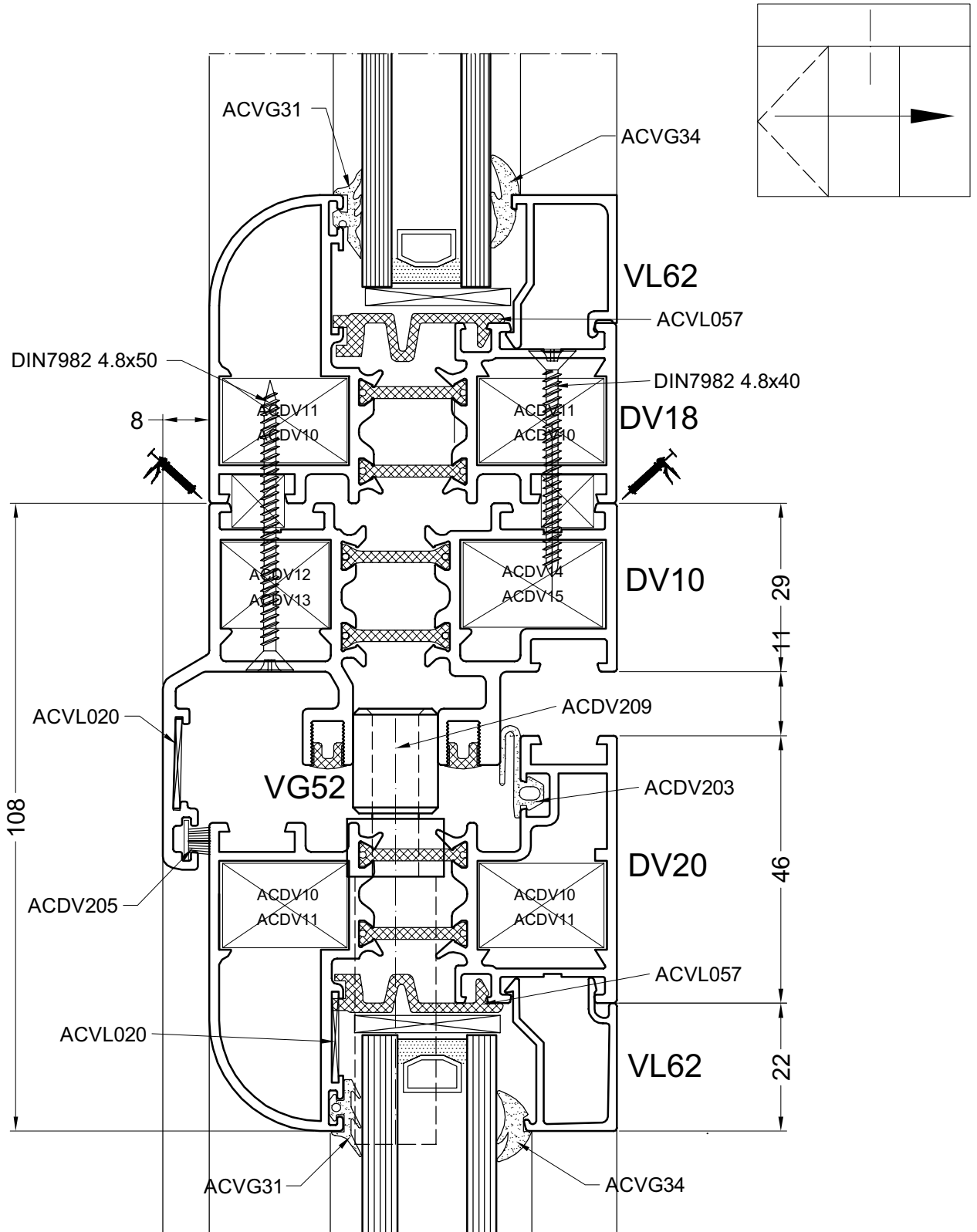

door28

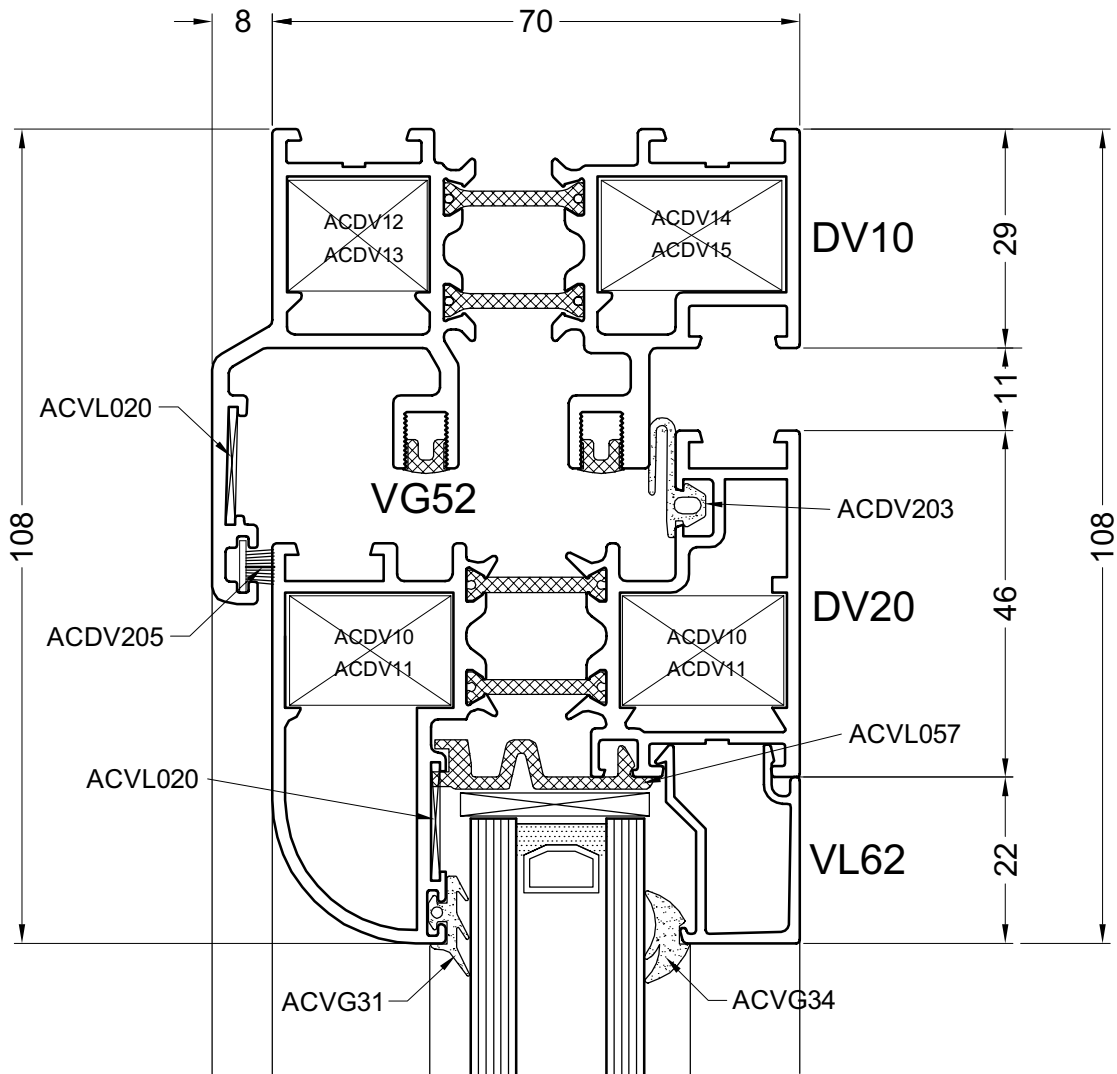

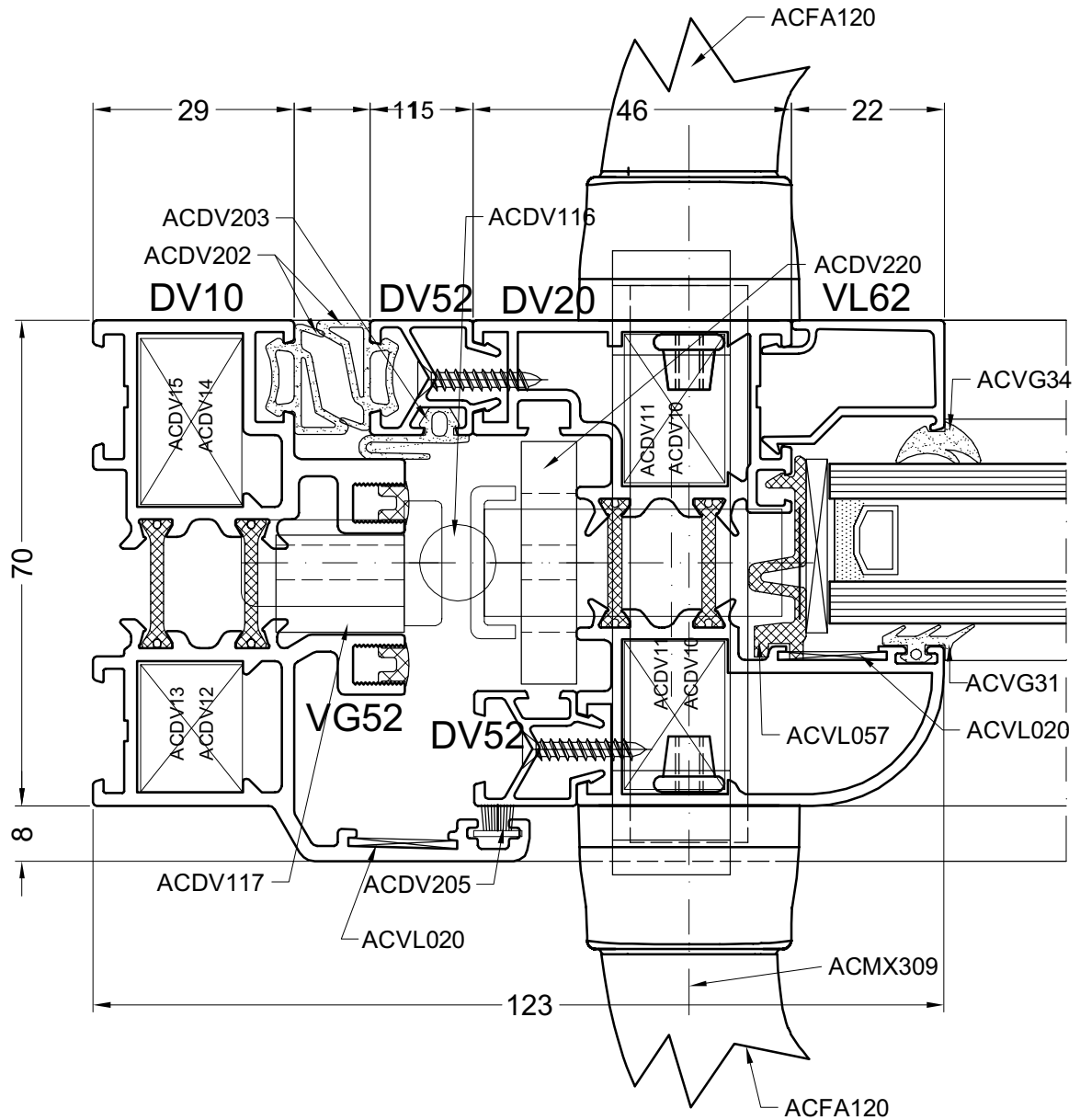

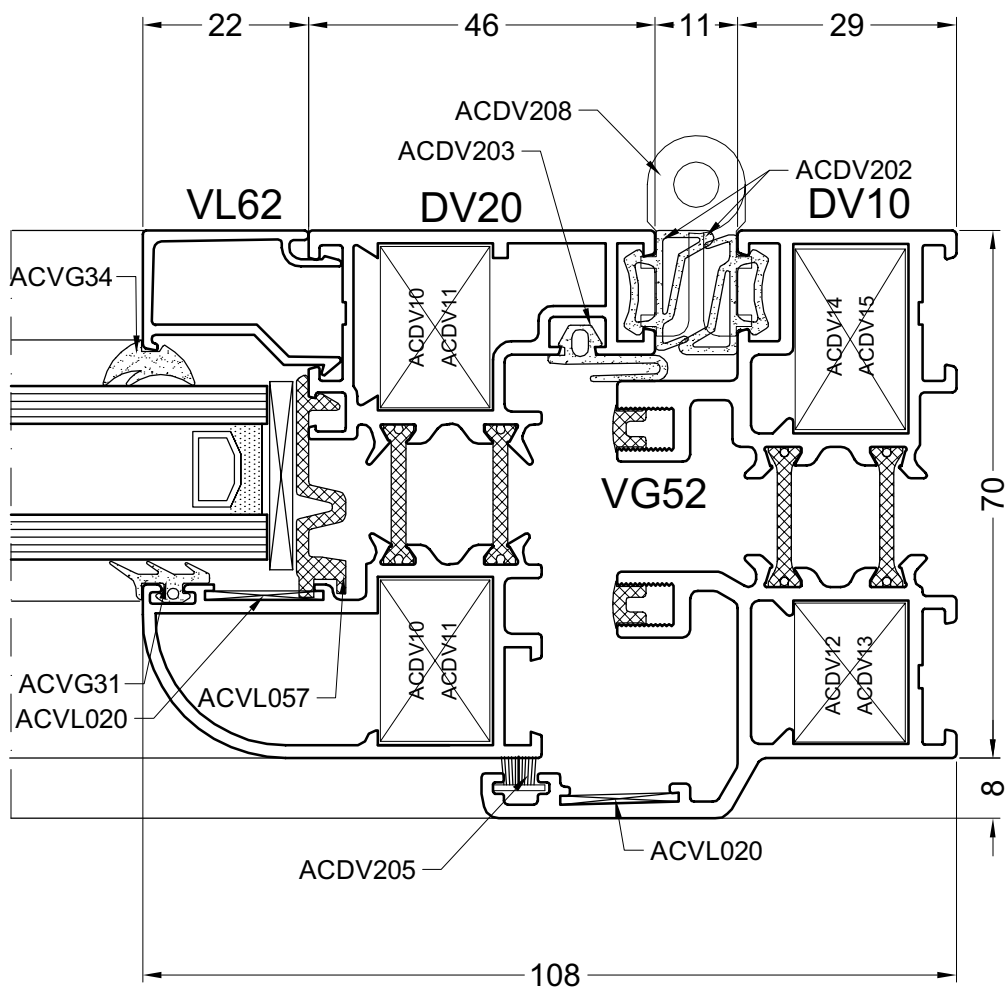

door31

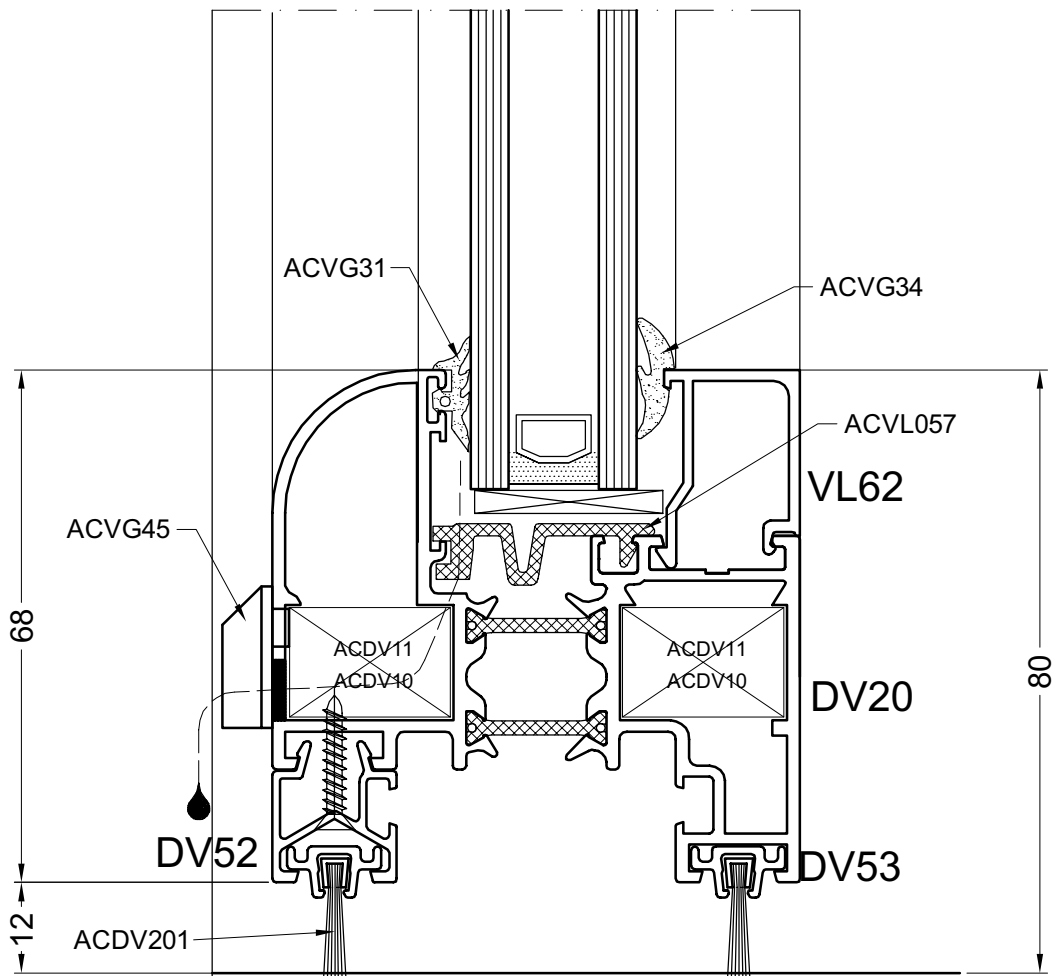

Glasdikte (mm) Epaisseur de verre (mm) Glas dicke (mm) Glass thickness (mm)	Rubber buiten Joint ext. Glasdichtung ausser Gasket outside	Rubber binnen Joint int. Glasdichtung innen Gasket inside	Glaslat Latte a vitrage Verglasung latte Glazing bead
4	ACVG31	ACVG340	VL65
5	ACVG31	ACVG34	VL65
6	ACVG31	ACVG33	VL65
7	ACVG31	ACVG32	VL65
8	ACVG31	ACVG340	VL640 & IP066
9	ACVG31	ACVG34	VL640 & IP066
10	ACVG31	ACVG33	VL640 & IP066
11	ACVG31	ACVG32	VL640 & IP066
12	ACVG31	ACVG340	VL64 & VL164
13	ACVG31	ACVG34	VL64 & VL164
14	ACVG31	ACVG33	VL64 & VL164
15	ACVG31	ACVG32	VL64 & VL164
16	ACVG31	ACVG34	VL630
17	ACVG31	ACVG33	VL630
18	ACVG31	ACVG32	VL630
19	ACVG31	ACVG34	VL63 & VL163
20	ACVG31	ACVG33	VL63 & VL163
21	ACVG31	ACVG32	VL63 & VL163
22	ACVG31	ACVG34	VL162 & VL166
23	ACVG31	ACVG33	VL162 & VL166
24	ACVG31	ACVG32	VL162 & VL166
25	ACVG31	ACVG32	VL62 & VL66
26	ACVG31	ACVG33	VL612
27	ACVG31	ACVG32	VL612
28	ACVG31	ACVG33	VL611 & VL161
29	ACVG31	ACVG32	VL611 & VL161
30	ACVG31	ACVG340	VL610
31	ACVG31	ACVG34	VL610
32	ACVG31	ACVG33	VL610
33	ACVG31	ACVG32	VL610
34	ACVG31	ACVG340	VL61
35	ACVG31	ACVG34	VL61
36	ACVG31	ACVG33	VL61
37	ACVG31	ACVG32	VL61

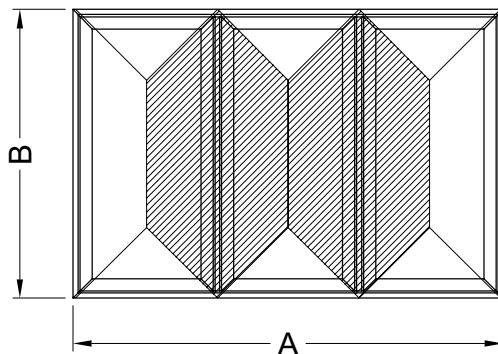

Max. vleugelgewicht
 Poids max. par vantail
 Max. flügelgewicht
 Max. weight of the vent

80 kg

$I_{xx} = 92 \text{ cm}^4$

$f_{max} = B/360 < 8 \text{ mm}$

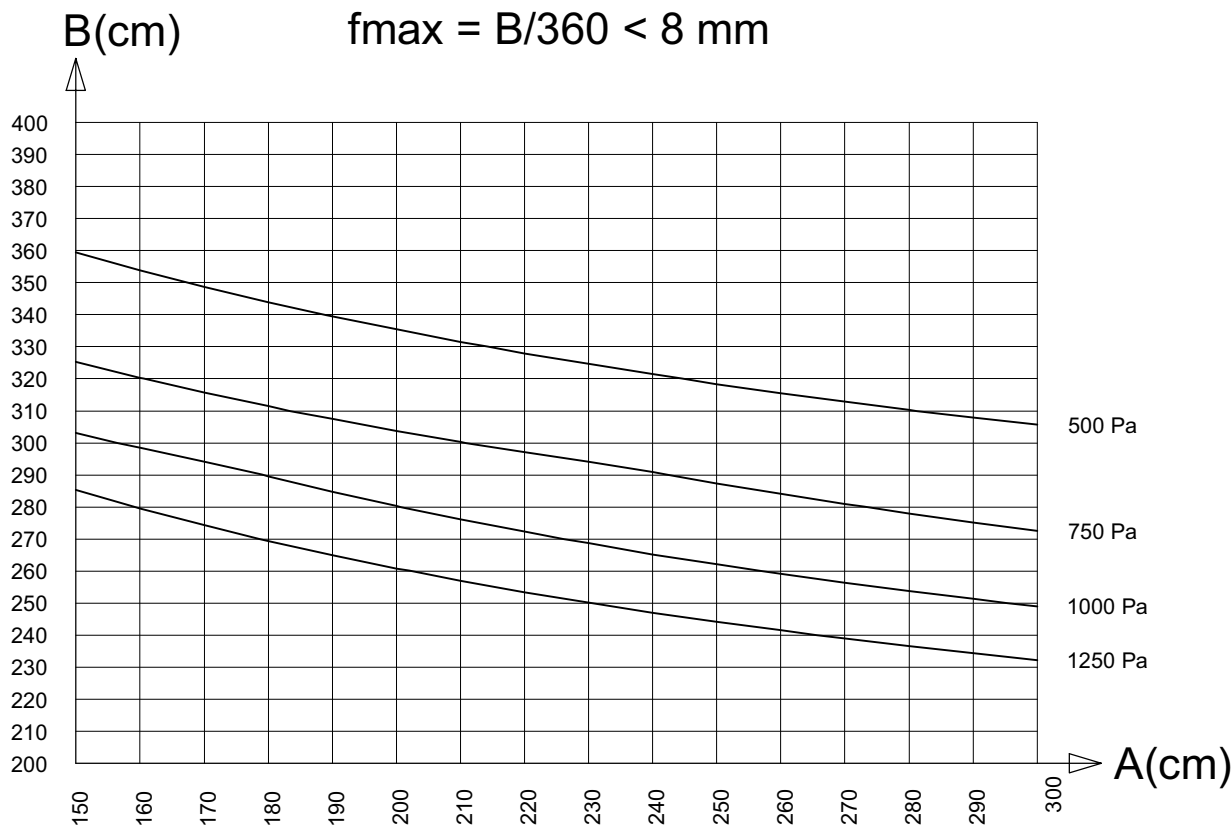

statica1

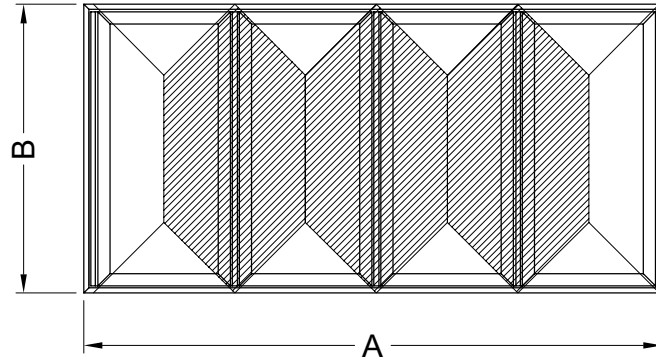

Max. vleugelgewicht
 Poids max. par vantail
 Max. flügelgewicht
 Max. weight of the vent

80 kg

$I_{xx} = 92 \text{ cm}^4$
 $f_{max} = B/360 < 8 \text{ mm}$

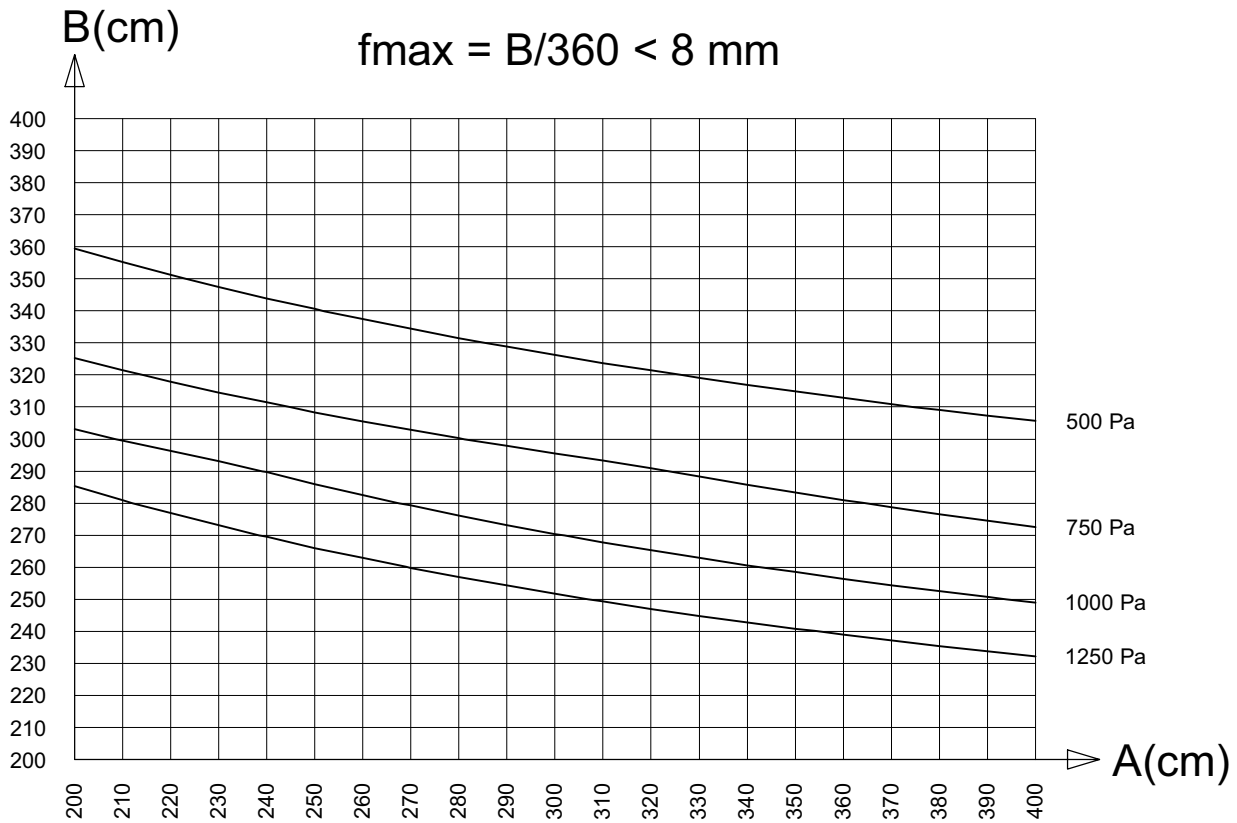

statica2

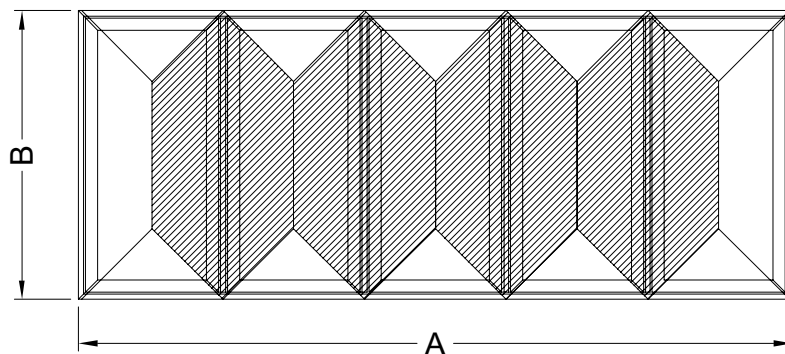

Max. vleugelgewicht
 Poids max. par vantail
 Max. flügelgewicht
 Max. weight of the vent

80 kg

$I_{xx} = 92 \text{ cm}^4$
 $f_{max} = B/360 < 8 \text{ mm}$

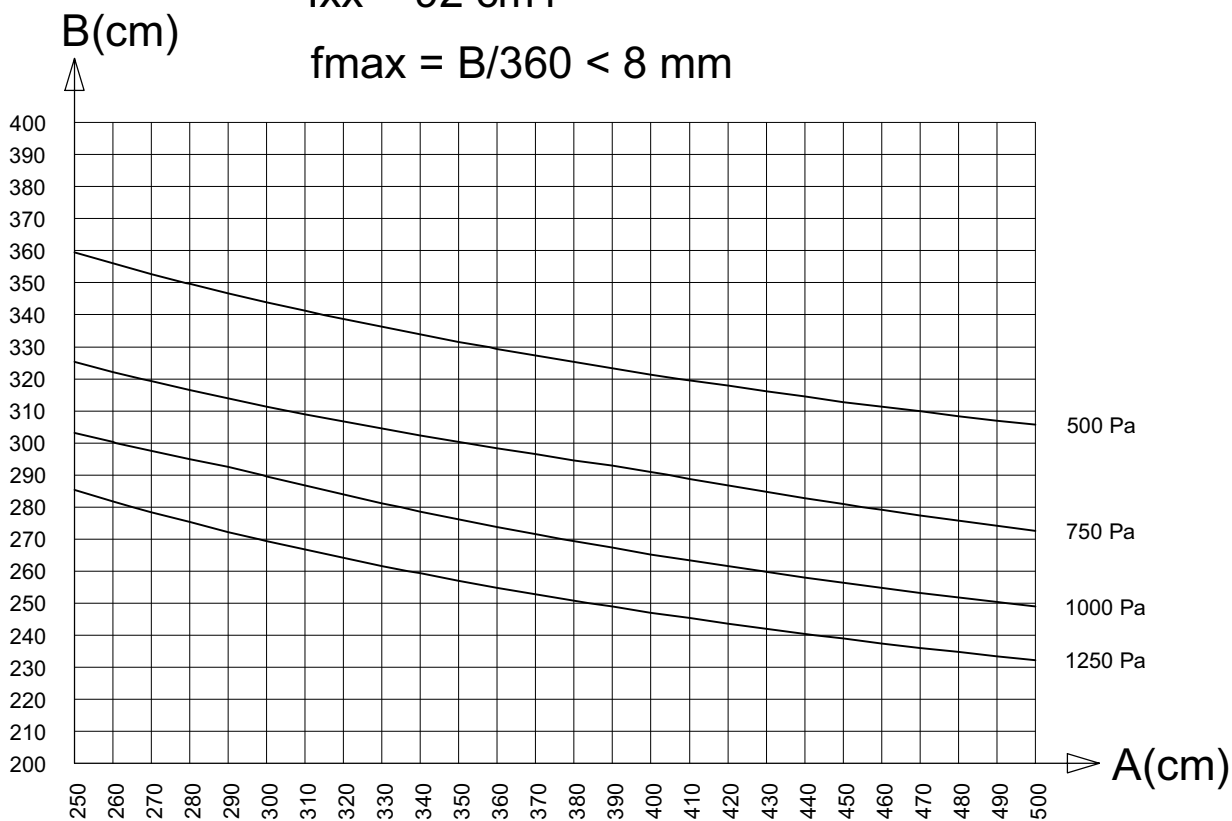

statica3

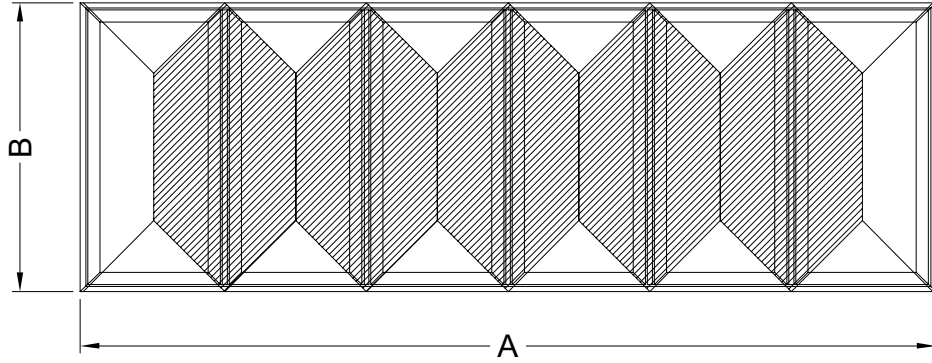

Max. vleugelgewicht
Poids max. par vantail
Max. flügelgewicht
Max. weight of the vent

80 kg

$I_{xx} = 92 \text{ cm}^4$
 $f_{max} = B/360 < 8 \text{ mm}$

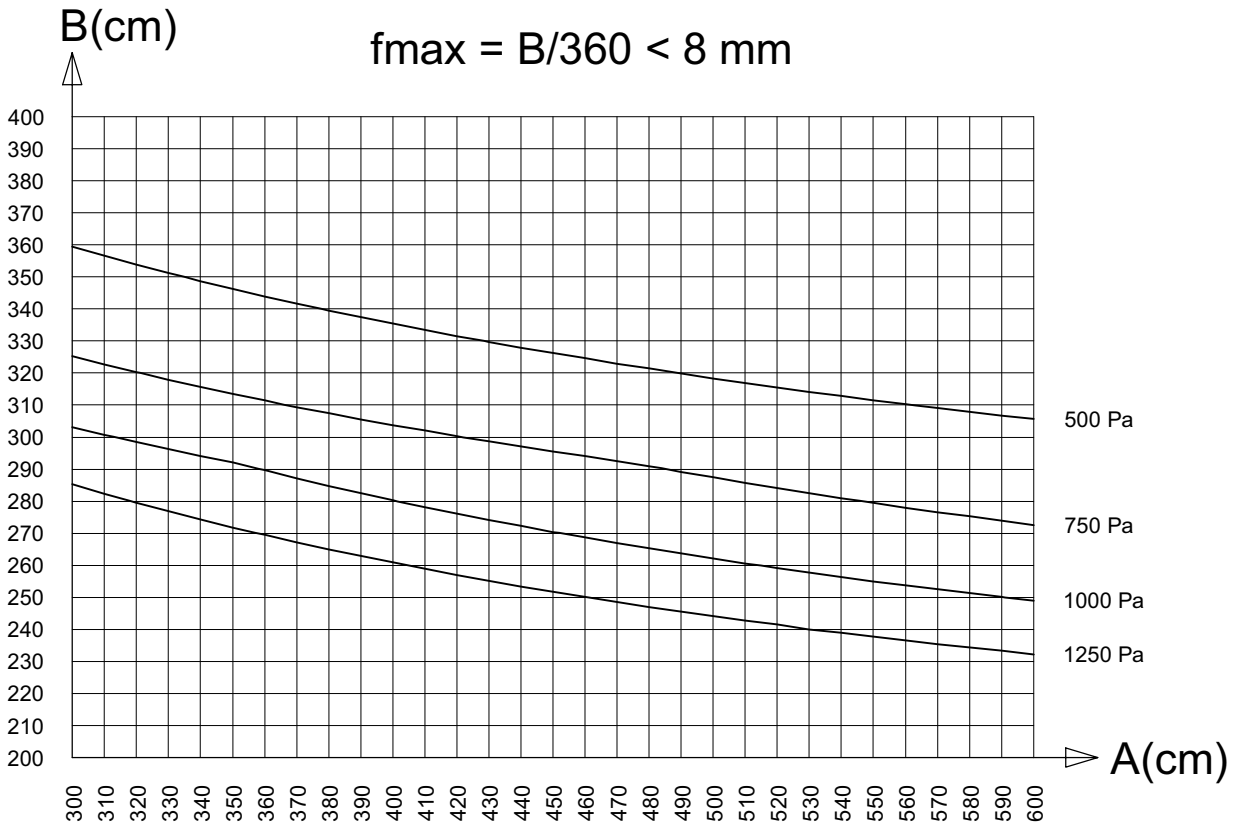

statica4

DV210I1

MET GEWONE DORPEL
AVEC SEUIL
MIT SCHWELLE
WITH THRESHOLD

MET STANGENSLUITING
AVEC SERRURE A TRINGLE
MIT TREIBRIEGELSCHLOSS
WITH EXTENDED BOLT LOCK

ZAAGTABELLEN - TABLES DE SCIAGES - ZUSCHNITT-TABELLEN - SAWING TABLES

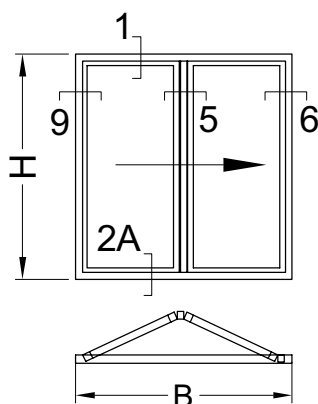

!! OPMERKING - REMARQUE - BEMERKUNG - REMARK !!

GLASMATEN B/2 - 204
DIM.VITRAGES
GLASMASSE H - 186
GLASS SIZES

PROFIELEN PROFILES PROFILE PROFILS

DV10		2		B
DV10		2		H
DV20		4		B/2 - 98.5
DV20		4		H-80
DV31		2		H-80
DV52		2		H-80
VG53		2		B-90
VG52		2		B-90
VG52		4		H-90
VL6*		4		B/2 - 190.5
VL6*		4		H-216

TOEBEHOREN ACCESSOIRES ZUBEHORTEILE ACCESSORIES

ACDV12/13	4	ACFA211	1	ACDV205	2H+2B
ACDV14/15	4	ACDV212	1	ACDV202	16H
ACDV10/11	16	ACDV213	2	ACDV203	5H+2B-1m
ACDV206	4	ACDV214	1set	ACVG31	4H+2B-1m
ACDV208	16	ACVL020	12	ACVG3*	4H+2B-1m
ACDV209	1	ACVL057	16		
ACDV210	1	ACVG45	2		

zaagl045

Type 1i (Chacal: DV310I1)

MET GEWONE DORPEL
AVEC SEUIL
MIT SCHWELLE
WITH THRESHOLD

MET STANGENSLUITING
AVEC SERRURE A TRINGLE
MIT TREIBRIEGELSCHLOSS
WITH EXTENDED BOLT LOCK

ZAAGTABELLEN - TABLES DE SCIAGES - ZUSCHNITT-TABELLEN - SAWING TABLES

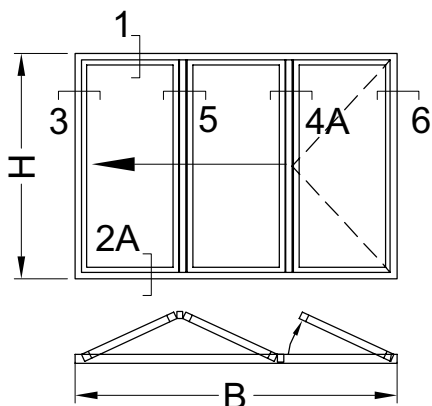

!! OPMERKING - REMARQUE - BEMERKUNG - REMARK !!

GLASMATEN B/3 - 166
DIM.VITRAGES
GLASMASSE H - 186
GLASS SIZES

PROFIELEN PROFILES PROFILE PROFILS

DV10		2		B
DV10		2		H
DV20		6		B/3 -60
DV20		6		H-80
DV31		2		H-80
VG53		2		B-90
VG52		2		B-90
VG52		4		H-90
VL6*		6		B/3 -152
VL6*		6		H-216

TOEBEHOREN ACCESSOIRES ZUBEHORTEILE ACCESSORIES

ACDV12/13	4	ACDV212	2	ACDV205	2H+2B
ACDV14/15	4	ACDV213	2	ACDV202	20H
ACDV10/11	24	ACDV214	2sets	ACDV203	6H+2B-1m
ACDV206	4	ACDV236	2	ACVG31	6H+2B-1m
ACDV208	20	ACVL020	16	ACVG3*	6H+2B-1m
ACDV209	1	ACVL057	24		
ACDV210	1	ACVG45	2		
ACFA211	2				

zaagi001

Type 2i (Chacal: DV314I1)

MET GEWONE DORPEL
AVEC SEUIL
MIT SCHWELLE
WITH THRESHOLD

MET STANGENSLUITING
AVEC SERRURE A TRINGLE
MIT TREIBRIEGELSCHLOSS
WITH EXTENDED BOLT LOCK

ZAAGTABELLEN - TABLES DE SCIAGES - ZUSCHNITT-TABELLEN - SAWING TABLES

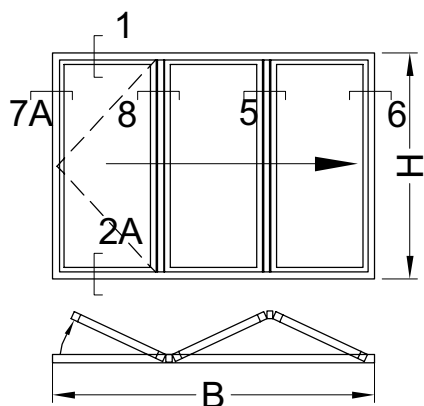

!! OPMERKING - REMARQUE - BEMERKUNG - REMARK !!

GLASMATEN B/3 - 166
DIM.VITRAGES
GLASMASSE H - 186
GLASS SIZES

PROFIELEN PROFILES PROFILE PROFILS

DV10		2		B
DV10		2		H
DV20		6		B/3 -60
DV20		6		H-80
DV31		2		H-80
VG53		2		B-90
VG52		2		B-90
VG52		4		H-90
VL6*		6		B/3 -152
VL6*		6		H-216

TOEBEHOREN ACCESSOIRES ZUBEHORTEILE ACCESSORIES

ACDV12/13	4	ACDV212	2	ACDV205	2H+2B
ACDV14/15	4	ACDV213	2	ACDV202	20H
ACDV10/11	24	ACDV214	2sets	ACDV203	6H+2B-1m
ACDV206	4	ACDV236	2	ACVG31	6H+2B-1m
ACDV208	20	ACVL020	16	ACVG3*	6H+2B-1m
ACDV209	1	ACVL057	24		
ACDV210	1	ACVG45	2		
ACFA211	2				

zaag1003

Type 3i (Chacal: DV418I1)

MET GEWONE DORPEL
AVEC SEUIL
MIT SCHWELLE
WITH THRESHOLD

MET STANGENSLUITING
AVEC SERRURE A TRINGLE
MIT TREIBRIEGELSCHLOSS
WITH EXTENDED BOLT LOCK

ZAAGTABELLEN - TABLES DE SCIAGES - ZUSCHNITT-TABELLEN - SAWING TABLES

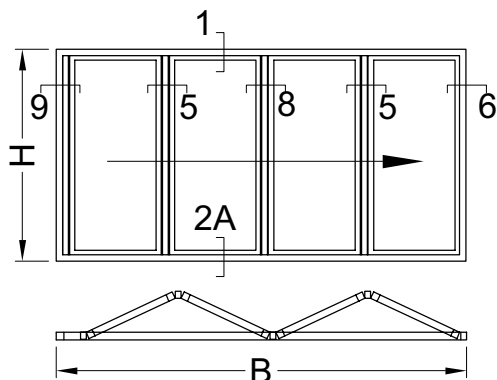

!! OPMERKING - REMARQUE - BEMERKUNG - REMARK !!

GLASMATEN B/4 - 180
DIM.VITRAGES
GLASMASSE H - 186
GLASS SIZES

PROFIELEN PROFILES PROFILE PROFILS

DV10		2		B
DV10		2		H
DV20		8		B/4 -74
DV20		8		H-80
DV31		4		H-80
DV52		2		H-80
VG53		2		B-90
VG52		2		B-90
VG52		4		H-90
VL6*		8		B/4 -166
VL6*		8		H-216

TOEBEHOREN ACCESSOIRES ZUBEHORTEILE ACCESSORIES

ACDV12/13	4	ACFA211	2	ACDV205	2H+2B
ACDV14/15	4	ACDV212	2	ACDV202	32H
ACDV10/11	32	ACDV213	4	ACDV203	9H+2B-1.3m
ACDV206	8	ACDV214	2sets	ACVG31	8H+2B-1.3m
ACDV208	32	ACVL020	20	ACVG3*	8H+2B-1.3m
ACDV209	2	ACVL057	32		
ACDV210	2	ACVG45	2		

zaagI005

Type 3i (Chacal: DV410I1)

MET GEWONE DORPEL
AVEC SEUIL
MIT SCHWELLE
WITH THRESHOLD

MET STANGENSLUITING
AVEC SERRURE A TRINGLE
MIT TREIBRIEGELSCHLOSS
WITH EXTENDED BOLT LOCK

ZAAGTABELLEN - TABLES DE SCIAGES - ZUSCHNITT-TABELLEN - SAWING TABLES

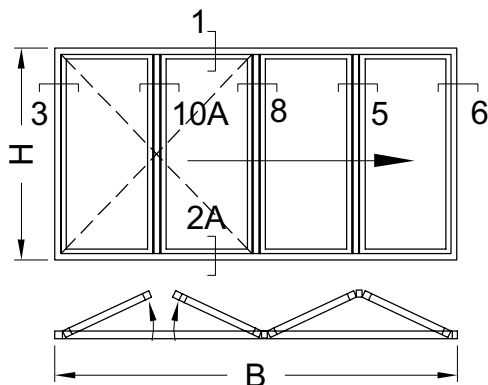

!! OPMERKING - REMARQUE - BEMERKUNG - REMARK !!

GLASMATEN B/4 - 160
DIM.VITRAGES
GLASMASSE H - 186
GLASS SIZES

PROFIELEN PROFILES PROFILE PROFILS

DV10		2		B
DV10		2		H
DV20		8		B/4 -54
DV20		8		H-80
DV31		3		H-80
VG53	∩	2		B-90
VG52	⌘	2		B-90
VG52	⌘	4		H-90
VL6*		8		B/4 -146
VL6*		8		H-216

TOEBEHOREN ACCESSOIRES ZUBEHORTEILE ACCESSORIES

ACDV12/13	4	ACDV212	3	ACDV205	2H+2B
ACDV14/15	4	ACDV213	4	ACDV202	24H
ACDV10/11	32	ACDV214	3sets	ACDV203	7H+2B-1.3m
ACDV206	6	ACDV236	2	ACVG31	8H+2B-1.3m
ACDV208	24	ACVL020	20	ACVG3*	8H+2B-1.3m
ACDV209	1	ACVL057	32		
ACDV210	1	ACVG45	2		
ACFA211	3				

Type 5i (Chacal: DV422I1)

MET GEWONE DORPEL
AVEC SEUIL
MIT SCHWELLE
WITH THRESHOLD

MET STANGENSLUITING
AVEC SERRURE A TRINGLE
MIT TREIBRIEGELSCHLOSS
WITH EXTENDED BOLT LOCK

ZAAGTABELLEN - TABLES DE SCIAGES - ZUSCHNITT-TABELLEN - SAWING TABLES

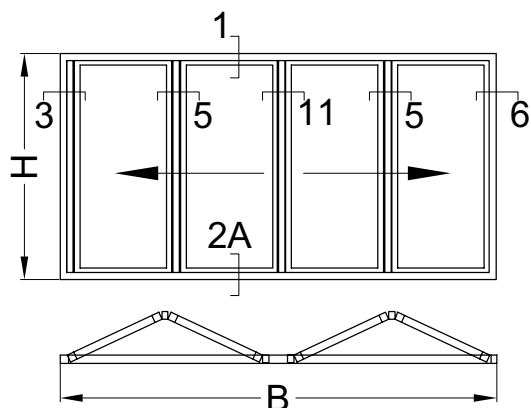

!! OPMERKING - REMARQUE - BEMERKUNG - REMARK !!

GLASMATEN DIM.VITRAGES B/4 - 180
GLASMASSE GLASS SIZES H - 186

PROFIELEN PROFILES PROFILE PROFILS

DV10		2		B
DV10		2		H
DV20		8		B/4 -74
DV20		8		H-80
DV31		4		H-80
VG53	n	2		B-90
VG52		2		B-90
VG52		4		H-90
VL6*		8		B/4 -166
VL6*		8		H-216
DV52		2		H-80

TOEBEHOREN ACCESSOIRES ZUBEHORTEILE ACCESSORIES

ACDV12/13	4	ACDV213	4	ACDV205	2H+2B
ACDV14/15	4	ACDV214	2sets	ACDV202	32H
ACDV10/11	32	ACVL020	20	ACDV203	8H+2B-1.3M
ACDV206	8	ACVL057	32	ACVG31	8H+2B-1.3M
ACDV208	32	ACVG45	2	ACVG3*	8H+2B-1.3M
ACDV209	2				
ACDV210	2				
ACFA211	2				
ACDV212	2				

zaagI008

Type 6i variant (Chacal: DV510I1)

MET GEWONE DORPEL
AVEC SEUIL
MIT SCHWELLE
WITH THRESHOLD

MET STANGENSLUITING
AVEC SERRURE A TRINGLE
MIT TREIBRIEGELSCHLOSS
WITH EXTENDED BOLT LOCK

ZAAGTABELLEN - TABLES DE SCIAGES - ZUSCHNITT-TABELLEN - SAWING TABLES

!! OPMERKING - REMARQUE - BEMERKUNG - REMARK !!

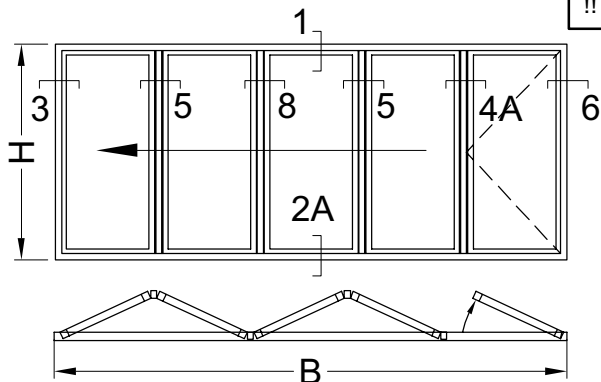

GLASMATEN B/5 - 161
DIM.VITRAGES
GLASMASSE H - 186
GLASS SIZES

PROFIELEN PROFILES PROFILE PROFILS

DV10		2		B
DV10		2		H
DV20		10		B/5 -55
DV20		10		H-80
DV31		4		H-80
VG53		2		B-90
VG52		2		B-90
VG52		4		H-90
VL6*		10		B/5 -147
VL6*		10		H-216

TOEBEHOREN ACCESSOIRES ZUBEHORTEILE ACCESSORIES

ACDV12/13	4	ACDV212	3	ACDV205	2H+2B
ACDV14/15	4	ACDV213	4	ACDV202	36H
ACDV10/11	40	ACDV214	3sets	ACDV203	10H+2B-1m
ACDV206	8	ACDV236	2	ACVG31	10H+2B-1m
ACDV208	36	ACVL020	24	ACVG3*	10H+2B-1m
ACDV209	2	ACVL057	40		
ACDV210	2	ACVG45	2		
ACFA211	3				

Type 6i variant (Chacal: DV514I1)

MET GEWONE DORPEL
AVEC SEUIL
MIT SCHWELLE
WITH THRESHOLDMET STANGENSLUITING
AVEC SERRURE A TRINGLE
MIT TREIBRIEGELSCHLOSS
WITH EXTENDED BOLT LOCK

ZAAGTABELLEN - TABLES DE SCIAGES - ZUSCHNITT-TABELLEN - SAWING TABLES

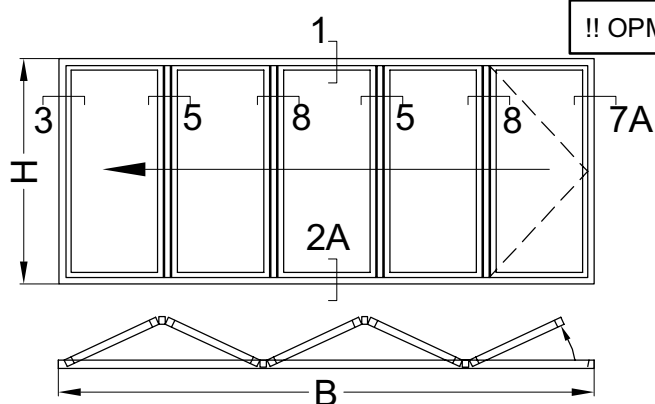

GLASMATEN	B/5 - 161
DIM.VITRAGES	
GLASMASSE	H - 186
GLASS SIZES	

PROFIELEN PROFILES PROFILE PROFILS

DV10		2		B
DV10		2		H
DV20		10		B/5-55
DV20		10		H-80
DV31		4		H-80
VG53	n	2		B-90
VL6*		10		B/5-147
VL6*		10		H-216
VG52		2		B-90
VG52		4		H-90

TOEBEHOREN ACCESSOIRES ZUBEHORTEILE ACCESSORIES

ACDV12/13	4	ACDV213	4	ACDV205	2H+2B
ACDV14/15	4	ACDV214	3sets	ACDV202	36H
ACDV10/11	40	ACDV236	2	ACDV203	10H+2B-1M
ACDV206	8	ACVL020	24	ACVG31	10H+2B-1M
ACDV208	36	ACVL057	40	ACVG3*	10H+2B-1M
ACDV209	2	ACVG45	2		
ACDV210	2				
ACFA211	3				
ACDV212	3				

zaagl011

Type 7i (Chacal: DV614I1)

MET GEWONE DORPEL
AVEC SEUIL
MIT SCHWELLE
WITH THRESHOLD

MET STANGENSLUITING
AVEC SERRURE A TRINGLE
MIT TREIBRIEGELSCHLOSS
WITH EXTENDED BOLT LOCK

ZAAGTABELLEN - TABLES DE SCIAGES - ZUSCHNITT-TABELLEN - SAWING TABLES

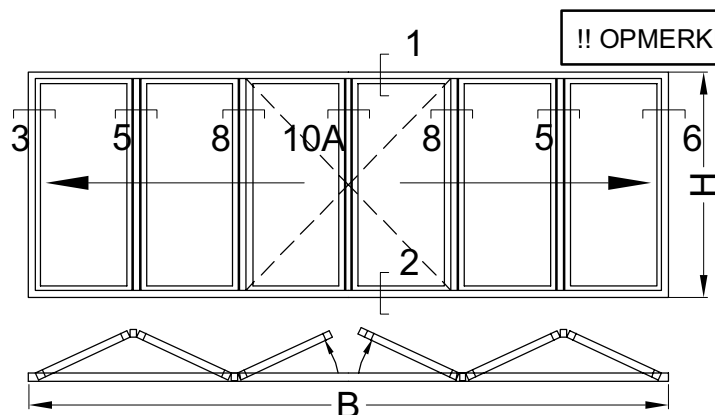

GLASMATEN DIM.VITRAGES B/6 - 158
GLASMASSE H - 186
GLASS SIZES H - 186

PROFIELEN PROFILES PROFILE PROFILS

DV10		2		B
DV10		2		H
DV20		12		B/6-52
DV20		12		H-80
DV31		5		H-80
VG53	∩	2		B-90
VL6*	מדידת	12		B/6-144
VL6*	מדידת	12		H-216
VG52	∩	2		B-90
VG52	∩	4		H-90

TOEBEHOREN ACCESSOIRES ZUBEHÖRTEILE ACCESSORIES

ACDV12/13	4	ACDV213	6	ACDV205	2H+2B
ACDV14/15	4	ACDV214	4sets	ACDV202	40H
ACDV10/11	48	ACDV236	2	ACDV203	11H+2B-1.3M
ACDV206	10	ACVL020	28	ACVG31	12H+2B-1.3M
ACDV208	40	ACVL057	48	ACVG3*	12H+2B-1.3M
ACDV209	2	ACVG45	2		
ACDV210	2				
ACFA211	4				
ACDV212	4				

zaag013

Type 7i (Chacal: DV622I1)

MET GEWONE DORPEL
AVEC SEUIL
MIT SCHWELLE
WITH THRESHOLD

MET STANGENSLUITING
AVEC SERRURE A TRINGLE
MIT TREIBRIEGELSCHLOSS
WITH EXTENDED BOLT LOCK

ZAAGTABELLEN - TABLES DE SCIAGES - ZUSCHNITT-TABELLEN - SAWING TABLES

!! OPMERKING - REMARQUE - BEMERKUNG - REMARK !!

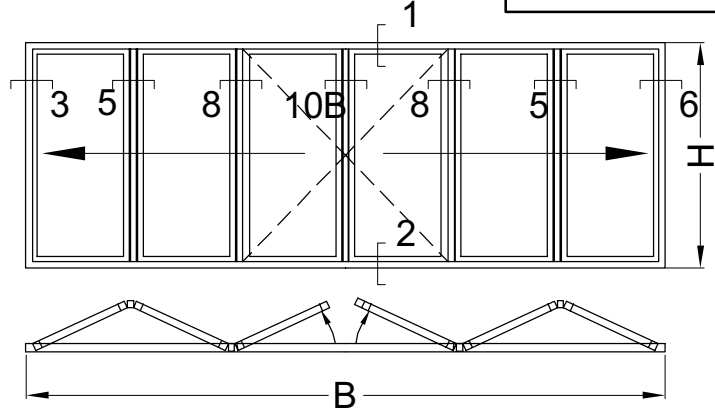

GLASMATEN B/6 - 160
DIM.VITRAGES
GLASMASSE H - 186
GLASS SIZES

PROFIELEN PROFILES PROFILE PROFILS

DV10		2		B
DV10		2		H
DV20		12		B/6-55
DV20		12		H-80
DV31		5		H-80
VG53	n	2		B-90
VL6*	תדיתתת	12		B/6-147
VL6*	תדיתתת	12		H-216
DV52	ז	1		H-80
DV52	ז	1		H-110
VG52	ז	2		B-90
VG52	ז	4		H-90

TOEBEHOREN ACCESSOIRES ZUBEHORTEILE ACCESSORIES

ACDV12/13	4	ACDV214	2sets	ACVG45	2
ACDV14/15	4	ACDV326	1	ACDV205	2H+2B
ACDV10/11	48	ACDV313	2	ACDV202	40H
ACDV206	10	ACVL127	1set	ACDV203	11H+2B-1.3M
ACDV208	40	ACVL020	28	ACVG31	12H+2B-1.3M
ACDV209	2	ACVL057	48	ACVG3*	12H+2B-1.3M
ACDV210	2	ACDV720	1	ACMX309	1
ACFA211	2	ACDV725	1	ACFA120	2
ACDV212	2	ACDV118	3		
ACDV213	4	ACDV215	1		

zaag1014

Type 1i (Chacal: DV318I1)

MET GEWONE DORPEL
AVEC SEUIL
MIT SCHWELLE
WITH THRESHOLD

MET CILINDERSLOT
AVEC SERRURE A CYLINDRE
MIT ZYLINDERSCHLOSS
WITH SECURITY LOCK

ZAAGTABELLEN - TABLES DE SCIAGES - ZUSCHNITT-TABELLEN - SAWING TABLES

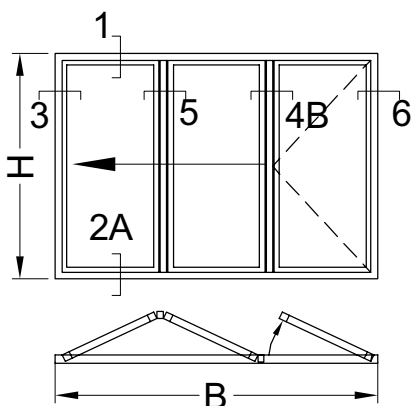

!! OPMERKING - REMARQUE - BEMERKUNG - REMARK !!

GLASMATEN B/3 - 171
DIM.VITRAGES
GLASMASSE H - 186
GLASS SIZES

PROFIELEN PROFILES PROFILE PROFILS

DV10		2		B
DV10		2		H
DV20		6		B/3 - 65
DV20		6		H-80
DV31		2		H-80
DV52	⌘	1		H-110
DV52	⌘	1		H-80
VG53	∩	2		B-90
VG52	⌘	2		B-90
VG52	⌘	4		H-90
VL6*	⌘	6		B/3 - 157
VL6*	⌘	6		H-216

TOEBEHOREN ACCESSOIRES ZUBEHORTEILE ACCESSORIES

ACDV12/13	4	ACDV212	1	ACVL020	16
ACDV14/15	4	ACDV213	2	ACVL057	24
ACDV10/11	24	ACDV214	1set	ACFA120	2
ACDV206	4	ACDV215	1	ACDV205	2H+2B
ACDV208	20	ACDV725	1	ACDV202	20H
ACDV209	1	ACDV118	3	ACDV203	6H+2B-1m
ACDV210	1	ACDV720	1	ACVG31	6H+2B-1m
ACFA211	1	ACMX309	1	ACVG3*	6H+2B-1m
		ACVG45	2		

Type 2i (Chacal: DV322I1)

MET GEWONE DORPEL
AVEC SEUIL
MIT SCHWELLE
WITH THRESHOLD

MET CILINDERSLOT
AVEC SERRURE A CYLINDRE
MIT ZYLINDERSCHLOSS
WITH SECURITY LOCK

ZAAGTABELLEN - TABLES DE SCIAGES - ZUSCHNITT-TABELLEN - SAWING TABLES

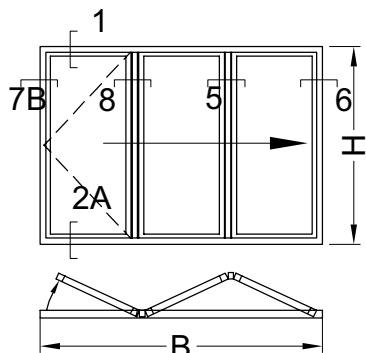

!! OPMERKING - REMARQUE - BEMERKUNG - REMARK !!

GLASMATEN B/3 - 170
DIM.VITRAGES
GLASMASSE H - 186
GLASS SIZES

PROFIELEN PROFILES PROFILE PROFILS

DV10		2		B
DV10		2		H
DV20		6		B/3 -64
DV20		6		H-80
DV31		2		H-80
DV52		1		H-80
DV52		1		H-110
VG53		2		B-90
VG52		2		B-90
VG52		4		H-90
VL6*		6		B/3 -156
VL6*		6		H-216

TOEBEHOREN ACCESSOIRES ZUBEHORTEILE ACCESSORIES

ACDV12/13	4	ACDV212	1	ACVL020	16
ACDV14/15	4	ACDV213	2	ACVL057	24
ACDV10/11	24	ACDV214	1set	ACFA120	2
ACDV206	4	ACDV215	1	ACDV205	2H+2B
ACDV208	20	ACDV725	1	ACDV202	20H
ACDV209	1	ACDV117	3	ACDV203	6H+2B-1m
ACDV210	1	ACDV720	1	ACVG31	6H+2B-1m
ACFA211	1	ACMX309	1	ACVG3*	6H+2B-1m
		ACVG45	2		

Type 4i (Chacal: DV414I1)

MET GEWONE DORPEL
AVEC SEUIL
MIT SCHWELLE
WITH THRESHOLD

MET CILINDERSLOT
AVEC SERRURE A CYLINDRE
MIT ZYLINDERSCHLOSS
WITH SECURITY LOCK

ZAAGTABELLEN - TABLES DE SCIAGES - ZUSCHNITT-TABELLEN - SAWING TABLES

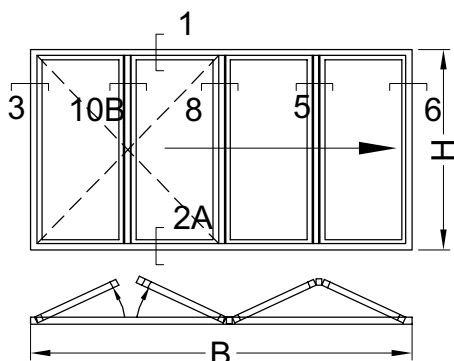

!! OPMERKING - REMARQUE - BEMERKUNG - REMARK !!

GLASMATEN	B/4 - 164
DIM.VITRAGES	
GLASMASSE	H - 186
GLASS SIZES	

PROFIELEN PROFILES PROFILE PROFILS

DV10		2		B
DV10		2		H
DV20		8		B/4-58
DV20		8		H-80
DV31		3		H-80
DV52		1		H-110
DV52		1		H-80
VG53		2		B-90
VG52		2		B-90
VG52		4		H-90
VL6*		8		B/4-150
VL6*		8		H-216

TOEBEHOREN ACCESSOIRES ZUBEHORTEILE ACCESSORIES

ACDV12/13	4	ACDV214	1set	ACVL020	20
ACDV14/15	4	ACDV326	1	ACVL057	32
ACDV10/11	32	ACDV313	2	ACFA120	2
ACDV206	6	ACVL127	1set	ACDV205	2H+2B
ACDV208	24	ACDV215	1	ACDV202	24H
ACDV209	1	ACDV725	1	ACDV203	7H+2B-1.3m
ACDV210	1	ACDV118	3	ACVG31	8H+2B-1.3m
ACFA211	1	ACDV720	1	ACVG3*	8H+2B-1.3m
ACDV212	1	ACMX309	1		
ACDV213	2	ACVG45	2		

zaagI007

Type 6i variant (Chacal: DV51811)

MET GEWONE DORPEL
AVEC SEUIL
MIT SCHWELLE
WITH THRESHOLD

MET CILINDERSLOT
AVEC SERRURE A CYLINDRE
MIT ZYLINDERSCHLOSS
WITH SECURITY LOCK

ZAAGTABELLEN - TABLES DE SCIAGES - ZUSCHNITT-TABELLEN - SAWING TABLES

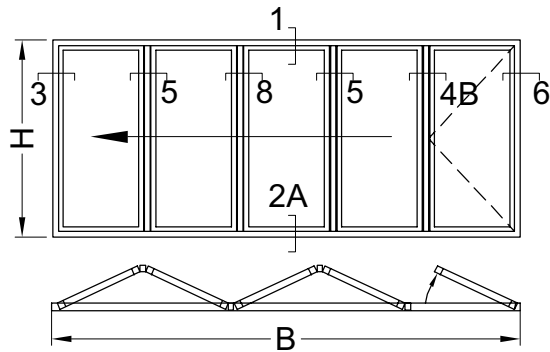

!! OPMERKING - REMARQUE - BEMERKUNG - REMARK !!

GLASMATEN B/5 - 164
DIM.VITRAGES
GLASMASSE H - 186
GLASS SIZES

PROFIELEN PROFILES PROFILE PROFILS

DV10		2		B
DV10		2		H
DV20		10		B/5 -58
DV20		10		H-80
DV31		4		H-80
VG53		2		B-90
VL6*		10		B/5 -150
VL6*		10		H-216
DV52		1		H-80
DV52		1		H-110
VG52		2		B-90
VG52		4		H-90

TOEBEHOREN ACCESSOIRES ZUBEHORTEILE ACCESSORIES

ACDV12/13	4	ACDV214	2sets	ACDV205	2H+2B
ACDV14/15	4	ACVL020	24	ACDV202	36H
ACDV10/11	40	ACVL057	40	ACDV203	10H+2B-1m
ACDV206	8	ACDV725	1	ACVG31	10H+2B-1m
ACDV208	36	ACDV118	3	ACVG3*	10H+2B-1m
ACDV209	2	ACDV720	1		
ACDV210	2	ACDV215	1		
ACFA211	2	ACMX309	1		
ACDV212	2	ACFA120	2		
ACDV213	4	ACVG45	2		

zaagl010

Type 6i (Chacal: DV52211)

MET GEWONE DORPEL
AVEC SEUIL
MIT SCHWELLE
WITH THRESHOLD

MET CILINDERSLOT
AVEC SERRURE A CYLINDRE
MIT ZYLINDERSCHLOSS
WITH SECURITY LOCK

ZAAGTABELLEN - TABLES DE SCIAGES - ZUSCHNITT-TABELLEN - SAWING TABLES

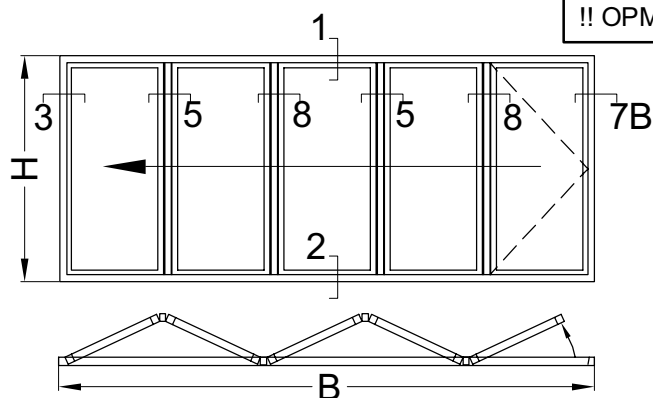

!! OPMERKING - REMARQUE - BEMERKUNG - REMARK !!

GLASMATEN B/5 - 164
DIM.VITRAGES
GLASMASSE H - 186
GLASS SIZES

PROFIELEN PROFILES PROFILE PROFILS

DV10		2		B
DV10		2		H
DV20		10		B/5-58
DV20		10		H-80
DV31		4		H-80
VG53		2		B-90
VL6*		10		B/5-150
VL6*		10		H-216
DV52		1		H-80
DV52		1		H-110
VG52		2		B-90
VG52		4		H-90

TOEBEHOREN ACCESSOIRES ZUBEHÖRTEILE ACCESSORIES

ACDV12/13	4	ACDV213	4	ACDV205	2H+2B
ACDV14/15	4	ACDV214	2sets	ACDV202	36H
ACDV10/11	40	ACVL020	24	ACDV203	10H+2B-1M
ACDV206	8	ACVL057	40	ACVG31	10H+2B-1M
ACDV208	36	ACDV720	1	ACVG3*	10H+2B-1M
ACDV209	2	ACDV725	1	ACMX309	1
ACDV210	2	ACDV117	3	ACFA120	2
ACFA211	2	ACDV215	1		
ACDV212	2	ACVG45	2		

zaag1012

DV212E1

MET GEWONE DORPEL
AVEC SEUIL
MIT SCHWELLE
WITH THRESHOLD

MET STANGENSLUITING
AVEC SERRURE A TRINGLE
MIT TREIBRIEGELSCHLOSS
WITH EXTENDED BOLT LOCK

ZAAGTABELLEN - TABLES DE SCIAGES - ZUSCHNITT-TABELLEN - SAWING TABLES

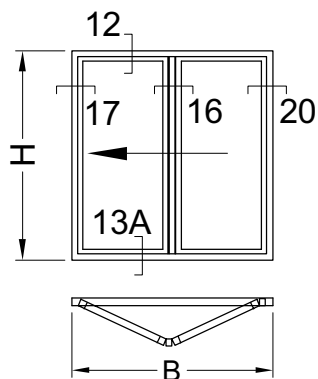

!! OPMERKING - REMARQUE - BEMERKUNG - REMARK !!

GLASMATEN B/2 - 204
DIM.VITRAGES
GLASMASSE H - 186
GLASS SIZES

PROFIELEN PROFILES PROFILE PROFILS

DV10		2		B
DV10		2		H
DV21		4		B/2 - 98.5
DV21		4		H-80
DV31		2		H-80
DV52		2		H-80
VG53		2		B-90
VL6*		4		B/2 - 190.5
VL6*		4		H-216
VG52		2		B-90
VG52		4		H-90

TOEBEHOREN ACCESSOIRES ZUBEHORTEILE ACCESSORIES

ACDV12/13	4	ACDV213	2	ACDV205	2H+2B
ACDV14/15	4	ACDV214	1set	ACDV202	16H
ACDV10/11	16	ACVL020	12	ACDV203	5H+2B-1.3m
ACDV206	4	ACVL057	16	ACVG31	4H+2B-1.3m
ACDV208	16	ACVG45	2	ACVG3*	4H+2B-1.3m
ACDV209	1				
ACDV210	1				
ACFA211	1				
ACDV212	1				

zaagI047

Type 1e (Chacal: DV312E1)

MET GEWONE DORPEL
AVEC SEUIL
MIT SCHWELLE
WITH THRESHOLD

MET STANGENSLUITING
AVEC SERRURE A TRINGLE
MIT TREIBRIEGELSCHLOSS
WITH EXTENDED BOLT LOCK

ZAAGTABELLEN - TABLES DE SCIAGES - ZUSCHNITT-TABELLEN - SAWING TABLES

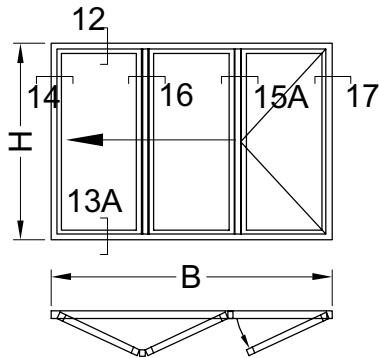

!! OPMERKING - REMARQUE - BEMERKUNG - REMARK !!

GLASMATEN B/3 - 170
DIM.VITRAGES
GLASMASSE H - 186
GLASS SIZES

PROFIELEN PROFILES PROFILE PROFILS

DV10		2		B
DV10		2		H
DV21		6		B/3 -64
DV21		6		H-80
DV31		2		H-80
VG53		2		B-90
VL6*		6		B/3 -156
VL6*		6		H-216
DV52		1		H-110
DV52		1		H-80
VG52		2		B-90
VG52		4		H-90

TOEBEHOREN ACCESSOIRES ZUBEHORTEILE ACCESSORIES

ACDV12/13	4	ACDV214	2sets	ACDV205	2H+2B
ACDV14/15	4	ACDV236	2	ACDV202	20H
ACDV10/11	24	ACVL020	16	ACDV203	6H+2B-1m
ACDV206	4	ACVL057	24	ACVG31	6H+2B-1m
ACDV208	20	ACVG45	2	ACVG3*	6H+2B-1m
ACDV209	1				
ACDV210	1				
ACFA211	2				
ACDV212	2				
ACDV213	2				

zaag015

Type 3e (Chacal: DV420E1)

MET GEWONE DORPEL
AVEC SEUIL
MIT SCHWELLE
WITH THRESHOLD

MET STANGENSLUITING
AVEC SERRURE A TRINGLE
MIT TREIBRIEGELSCHLOSS
WITH EXTENDED BOLT LOCK

ZAAGTABELLEN - TABLES DE SCIAGES - ZUSCHNITT-TABELLEN - SAWING TABLES

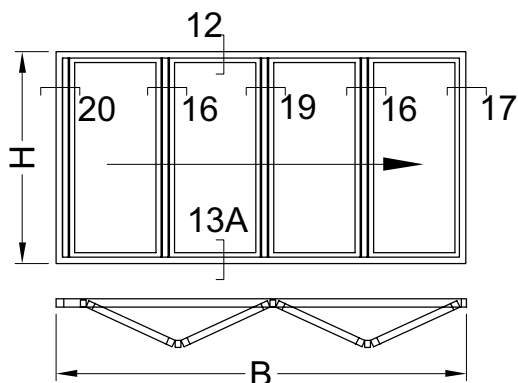

!! OPMERKING - REMARQUE - BEMERKUNG - REMARK !!

GLASMATEN B/4 - 180
DIM.VITRAGES
GLASMASSE H - 186
GLASS SIZES

PROFIELEN PROFILES PROFILE PROFILS

DV10		2		B
DV10		2		H
DV21		8		B/4 -74
DV21		8		H-80
DV31		4		H-80
DV52		2		H-80
VG53		2		B-90
VL6*		8		B/4 -166
VL6*		8		H-216
VG52		2		B-90
VG52		4		H-90

TOEBEHOREN ACCESSOIRES ZUBEHORTEILE ACCESSORIES

ACDV12/13	4	ACDV213	4	ACDV205	2H+2B
ACDV14/15	4	ACDV214	2sets	ACDV202	32H
ACDV10/11	32	ACVL020	20	ACDV203	9H+2B-1.3m
ACDV206	8	ACVL057	32	ACVG31	8H+2B-1.3m
ACDV208	32	ACVG45	2	ACVG3*	8H+2B-1.3m
ACDV209	2				
ACDV210	2				
ACFA211	2				
ACDV212	2				

zaagl019

Type 4e (Chacal: DV412E1)

MET GEWONE DORPEL
AVEC SEUIL
MIT SCHWELLE
WITH THRESHOLD

MET STANGENSLUITING
AVEC SERRURE A TRINGLE
MIT TREIBRIEGELSCHLOSS
WITH EXTENDED BOLT LOCK

ZAAGTABELLEN - TABLES DE SCIAGES - ZUSCHNITT-TABELLEN - SAWING TABLES

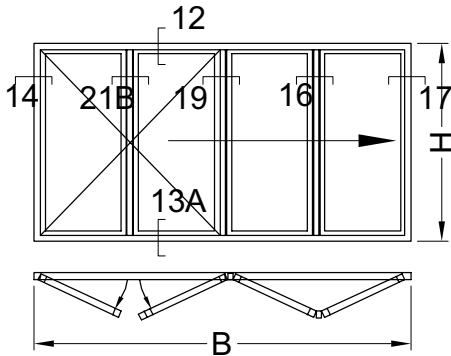

!! OPMERKING - REMARQUE - BEMERKUNG - REMARK !!

GLASMATEN B/4 - 164
DIM.VITRAGES
GLASMASSE H - 186
GLASS SIZES

PROFIELEN PROFILES PROFILE PROFILS

DV10		2		B
DV10		2		H
DV21		8		B/4-58
DV21		8		H-80
DV31		3		H-80
DV52		1		H-110
DV52		1		H-80
VG53		2		B-90
VL6*		8		B/4-150
VL6*		8		H-216
VG52		2		B-90
VG52		4		H-90

TOEBEHOREN ACCESSOIRES ZUBEHORTEILE ACCESSORIES

ACDV12/13	4	ACDV214	3sets	ACDV205	2H+2B
ACDV14/15	4	ACDV236	2	ACDV202	24H
ACDV10/11	32	ACVL020	20	ACDV203	7H+2B-1.3m
ACDV206	6	ACVL057	32	ACVG31	8H+2B-1.3m
ACDV208	24	ACVG45	2	ACVG3*	8H+2B-1.3m
ACDV209	1				
ACDV210	1				
ACFA211	3				
ACDV212	3				
ACDV213	4				

zaag020

Type 5e (Chacal: DV424E1)

MET GEWONE DORPEL
AVEC SEUIL
MIT SCHWELLE
WITH THRESHOLD

MET STANGENSLUITING
AVEC SERRURE A TRINGLE
MIT TREIBRIEGELSCHLOSS
WITH EXTENDED BOLT LOCK

ZAAGTABELLEN - TABLES DE SCIAGES - ZUSCHNITT-TABELLEN - SAWING TABLES

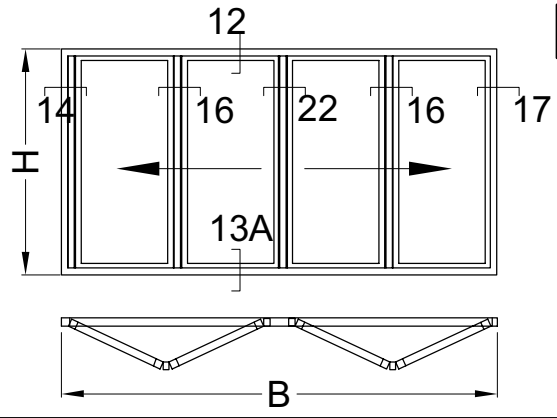

!! OPMERKING - REMARQUE - BEMERKUNG - REMARK !!

GLASMATEN B/4 - 180
DIM.VITRAGES
GLASMASSE H - 186
GLASS SIZES

PROFIELEN PROFILES PROFILE PROFILS

DV10		2		B
DV10		2		H
DV21		8		B/4 -74
DV21		8		H-80
DV31		4		H-80
DV52		2		H-80
VG53		2		B-90
VL6*		8		B/4 -166
VL6*		8		H-216
VG52		2		B-90
VG52		4		H-90

TOEBEHOREN ACCESSOIRES ZUBEHORTEILE ACCESSORIES

ACDV12/13	4	ACDV213	4	ACDV205	2H+2B
ACDV14/15	4	ACDV214	2sets	ACDV202	32H
ACDV10/11	32	ACVL020	20	ACDV203	8H+2B-1.3M
ACDV206	8	ACVL057	32	ACVG31	8H+2B-1.3M
ACDV208	32	ACVG45	2	ACVG3*	8H+2B-1.3M
ACDV209	2				
ACDV210	2				
ACFA211	2				
ACDV212	2				

zaag1022

Type 6e variant (Chacal: DV512E1)

MET GEWONE DORPEL
AVEC SEUIL
MIT SCHWELLE
WITH THRESHOLD

MET STANGENSLUITING
AVEC SERRURE A TRINGLE
MIT TREIBRIEGELSCHLOSS
WITH EXTENDED BOLT LOCK

ZAAGTABELLEN - TABLES DE SCIAGES - ZUSCHNITT-TABELLEN - SAWING TABLES

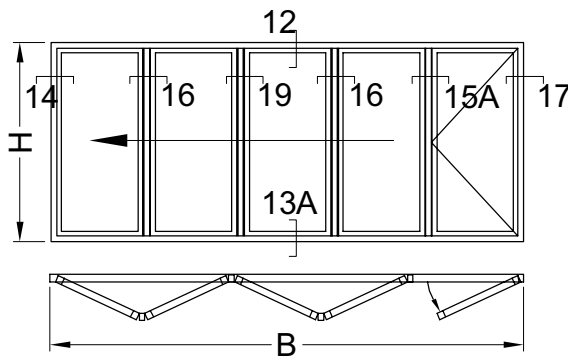

!! OPMERKING - REMARQUE - BEMERKUNG - REMARK !!

GLASMATEN DIM.VITRAGES B/5 - 164
GLASMASSE GLASS SIZES H - 186

PROFIELEN PROFILES PROFILE PROFILS

DV10		2		B
DV10		2		H
DV21		10		B/5 -58
DV21		10		H-80
DV31		4		H-80
VG53		2		B-90
VL6*		10		B/5 -150
VL6*		10		H-216
DV52		1		H-110
DV52		1		H-80
VG52		2		B-90
VG52		4		H-90

TOEBEHOREN ACCESSOIRES ZUBEHORTEILE ACCESSORIES

ACDV12/13	4	ACDV214	3sets	ACDV205	2H+2B
ACDV14/15	4	ACDV236	2	ACDV202	36H
ACDV10/11	40	ACVL020	24	ACDV203	10H+2B-1m
ACDV206	8	ACVL057	40	ACVG31	10H+2B-1m
ACDV208	36	ACVG45	2	ACVG3*	10H+2B-1m
ACDV209	2				
ACDV210	2				
ACFA211	3				
ACDV212	3				
ACDV213	4				

zaagI023

Type 7e (Chacal: DV616E1)

MET GEWONE DORPEL
AVEC SEUIL
MIT SCHWELLE
WITH THRESHOLD

MET STANGENSLUITING
AVEC SERRURE A TRINGLE
MIT TREIBRIEGELSCHLOSS
WITH EXTENDED BOLT LOCK

ZAAGTABELLEN - TABLES DE SCIAGES - ZUSCHNITT-TABELLEN - SAWING TABLES

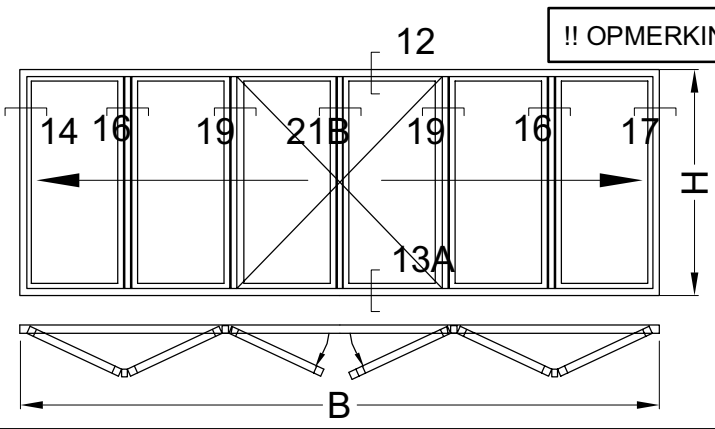

!! OPMERKING - REMARQUE - BEMERKUNG - REMARK !!

GLASMATEN B/6 - 160
DIM.VITRAGES
GLASMASSE H - 186
GLASS SIZES

PROFIELEN PROFILES PROFILE PROFILS

DV10		2		B
DV10		2		H
DV21		12		B/6-55
DV21		12		H-80
DV31		5		H-80
VG53	n	2		B-90
VL6*		12		B/6-147
VL6*		12		H-216
DV52	#	1		H-80
DV52	#	1		H-110
VG52	£	2		B-90
VG52	£	4		H-90

TOEBEHOREN ACCESSOIRES ZUBEHORTEILE ACCESSORIES

ACDV12/13	4	ACDV213	6	ACDV205	2H+2B
ACDV14/15	4	ACDV214	4sets	ACDV202	40H
ACDV10/11	48	ACDV236	2	ACDV203	11H+2B-1.3M
ACDV206	10	ACVL020	28	ACVG31	12H+2B-1.3M
ACDV208	40	ACVL057	48	ACVG3*	12H+2B-1.3M
ACDV209	2	ACVG45	2		
ACDV210	2				
ACFA211	4				
ACDV212	4				

zaag1027

Type 1e (Chacal: DV320E1)

MET GEWONE DORPEL
AVEC SEUIL
MIT SCHWELLE
WITH THRESHOLD

MET CILINDERSLOT
AVEC SERRURE A CYLINDRE
MIT ZYLINDERSCHLOSS
WITH SECURITY LOCK

ZAAGTABELLEN - TABLES DE SCIAGES - ZUSCHNITT-TABELLEN - SAWING TABLES

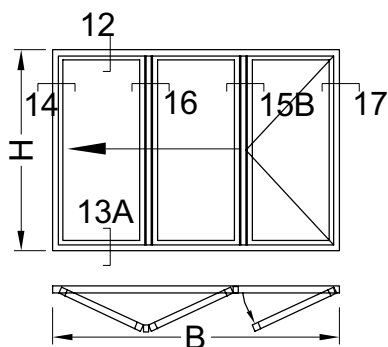

!! OPMERKING - REMARQUE - BEMERKUNG - REMARK !!

GLASMATEN B/3 - 170
DIM.VITRAGES
GLASMASSE H - 186
GLASS SIZES

PROFIELEN PROFILES PROFILE PROFILS

DV10		2		B
DV10		2		H
DV21		6		B/3 -64
DV21		6		H-80
DV31		2		H-80
DV52		1		H-110
DV52		1		H-80
VG53		2		B-90
VL6*		6		B/3 -156
VL6*		6		H-216
VG52		2		B-90
VG52		4		H-90

TOEBEHOREN ACCESSOIRES ZUBEHORTEILE ACCESSORIES

ACDV12/13	4	ACDV212	1	ACVL020	16
ACDV14/15	4	ACDV213	2	ACVL057	24
ACDV10/11	24	ACDV214	1set	ACFA120	2
ACDV206	4	ACDV215	1	ACDV205	2H+2B
ACDV208	20	ACDV725	1	ACDV202	20H
ACDV209	1	ACDV118	3	ACDV203	6H+2B-1m
ACDV210	1	ACDV720	1	ACVG31	6H+2B-1m
ACFA211	1	ACMX309	1	ACVG3*	6H+2B-1m
		ACVG45	2		

zaagl016

Type 2e (Chacal: DV324E1)

MET GEWONE DORPEL
AVEC SEUIL
MIT SCHWELLE
WITH THRESHOLD

MET CILINDERSLOT
AVEC SERRURE A CYLINDRE
MIT ZYLINDERSCHLOSS
WITH SECURITY LOCK

ZAAGTABELLEN - TABLES DE SCIAGES - ZUSCHNITT-TABELLEN - SAWING TABLES

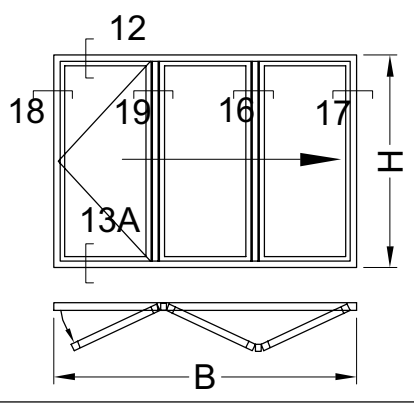

!! OPMERKING - REMARQUE - BEMERKUNG - REMARK !!

GLASMATEN DIM.VITRAGES B/3 - 170
GLASMASSE GLASS SIZES H - 186

PROFIELEN PROFILES PROFILE PROFILS

DV10		2		B
DV10		2		H
DV21		6		B/3 -64
DV21		6		H-80
DV31		2		H-80
DV52		1		H-80
DV52		1		H-110
VG53		2		B-90
VL6*		6		B/3 -156
VL6*		6		H-216
VG52		2		B-90
VG52		4		H-90

TOEBEHOREN ACCESSOIRES ZUBEHORTEILE ACCESSORIES

ACDV12/13	4	ACDV212	1	ACVL020	16
ACDV14/15	4	ACDV213	2	ACVL057	24
ACDV10/11	24	ACDV214	1set	ACFA120	2
ACDV206	4	ACDV215	1	ACDV205	2H+2B
ACDV208	20	ACDV725	1	ACDV202	12H
ACDV209	1	ACDV117	3	ACDV203	6H+2B-1m
ACDV210	1	ACDV720	1	ACVG31	6H+2B-1m
ACFA211	1	ACMX309	1	ACVG3*	6H+2B-1m

zaagl018

Type 4e (Chacal: DV416E1)

MET GEWONE DORPEL
AVEC SEUIL
MIT SCHWELLE
WITH THRESHOLD

MET CILINDERSLOT
AVEC SERRURE A CYLINDRE
MIT ZYLINDERSCHLOSS
WITH SECURITY LOCK

ZAAGTABELLEN - TABLES DE SCIAGES - ZUSCHNITT-TABELLEN - SAWING TABLES

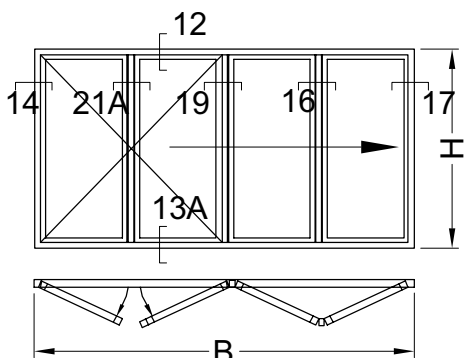

!! OPMERKING - REMARQUE - BEMERKUNG - REMARK !!

GLASMATEN DIM.VITRAGES B/4 - 164
GLASMASSE H - 186
GLASS SIZES H - 186

PROFIELEN PROFILES PROFILE PROFILS

DV10		2		B
DV10		2		H
DV21		8		B/4-58
DV21		8		H-80
DV31		3		H-80
DV52		1		H-110
DV52		1		H-80
VG53		2		B-90
VL6*		8		B/4-150
VL6*		8		H-216
VG52		2		B-90
VG52		4		H-90

TOEBEHOREN ACCESSOIRES ZUBEHORTEILE ACCESSORIES

ACDV12/13	4	ACDV214	1set	ACVL020	20
ACDV14/15	4	ACDV326	1	ACVL057	32
ACDV10/11	32	ACDV313	2	ACFA120	2
ACDV206	6	ACVL127	1set	ACDV205	2H+2B
ACDV208	24	ACDV215	1	ACDV202	24H
ACDV209	1	ACDV725	1	ACDV203	7H+2B-1.3m
ACDV210	1	ACDV118	3	ACVG31	8H+2B-1.3m
ACFA211	1	ACDV720	1	ACVG3*	8H+2B-1.3m
ACDV212	1	ACMX309	1		
ACDV213	2	ACVG45	2		

zaag021

Type 6e variant (Chacal: DV520E1)

MET GEWONE DORPEL
AVEC SEUIL
MIT SCHWELLE
WITH THRESHOLDMET CILINDERSLOT
AVEC SERRURE A CYLINDRE
MIT ZYLINDERSCHLOSS
WITH SECURITY LOCK

ZAAGTABELLEN - TABLES DE SCIAGES - ZUSCHNITT-TABELLEN - SAWING TABLES

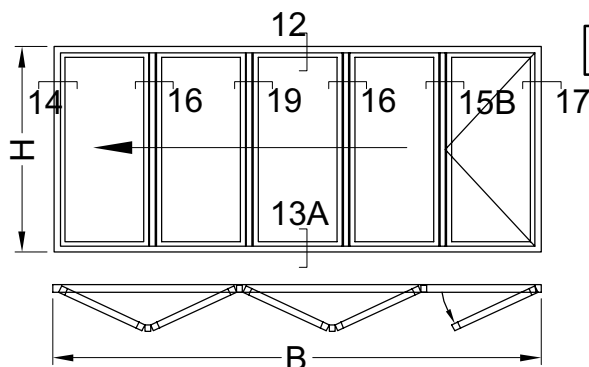

GLASMATEN	B/5 - 164
DIM.VITRAGES	
GLASMASSE	H - 186
GLASS SIZES	

PROFIELEN PROFILES PROFILE PROFILS

DV10		2		B
DV10		2		H
DV21		10		B/5 -58
DV21		10		H-80
DV31		4		H-80
DV52	⌘	1		H-80
DV52	⌘	1		H-110
VG53	∩	2		B-90
VL6*		10		B/5 -150
VL6*		10		H-216
VG52	⌘	2		B-90
VG52	⌘	4		H-90

TOEBEHOREN ACCESSOIRES ZUBEHORTEILE ACCESSORIES

ACDV12/13	4	ACDV212	2	ACDV720	1
ACDV14/15	4	ACDV213	4	ACDV215	1
ACDV10/11	40	ACDV214	2sets	ACDV205	2H+2B
ACDV206	8	ACVL020	24	ACDV202	36H
ACDV208	36	ACVL057	40	ACDV203	10H+2B-1m
ACDV209	2	ACDV725	1	ACVG31	10H+2B-1m
ACDV210	2	ACDV118	3	ACVG3*	10H+2B-1m
ACFA211	2	ACMX309	1	ACFA120	2
		ACVG45	2		

zaagl024

Type 6e variant (Chacal: DV524E1)

MET GEWONE DORPEL
AVEC SEUIL
MIT SCHWELLE
WITH THRESHOLD

MET CILINDERSLOT
AVEC SERRURE A CYLINDRE
MIT ZYLINDERSCHLOSS
WITH SECURITY LOCK

ZAAGTABELLEN - TABLES DE SCIAGES - ZUSCHNITT-TABELLEN - SAWING TABLES

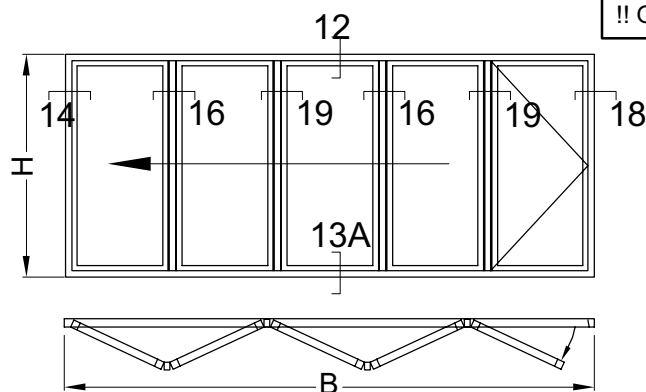

GLASMATEN B/5 - 164
DIM.VITRAGES
GLASMASSE H - 186
GLASS SIZES

PROFIELEN PROFILES PROFILE PROFILS

DV10		2		B
DV10		2		H
DV21		10		B/5-58
DV21		10		H-80
DV31		4		H-80
VG53	n	2		B-90
VL6*	מדידתן	10		B/5-150
VL6*	מדידתן	10		H-216
DV52	א	1		H-80
DV52	א	1		H-110
VG52	ב	2		B-90
VG52	ב	4		H-90

TOEBEHOREN ACCESSOIRES ZUBEHORTEILE ACCESSORIES

ACDV12/13	4	ACDV213	4	ACDV205	2H+2B
ACDV14/15	4	ACDV214	2sets	ACDV202	36H
ACDV10/11	40	ACVL020	24	ACDV203	10H+2B-1M
ACDV206	8	ACVL057	40	ACVG31	10H+2B-1M
ACDV208	36	ACDV720	1	ACVG3*	10H+2B-1M
ACDV209	2	ACDV725	1	ACMX309	1
ACDV210	2	ACDV117	3	ACFA120	2
ACFA211	2	ACDV215	1		
ACDV212	2	ACVG45	2		

zaagI026

Type 8e (Chacal: DV624E1)

MET GEWONE DORPEL
AVEC SEUIL
MIT SCHWELLE
WITH THRESHOLDMET CILINDERSLOT
AVEC SERRURE A CYLINDRE
MIT ZYLINDERSCHLOSS
WITH SECURITY LOCK

ZAAGTABELLEN - TABLES DE SCIAGES - ZUSCHNITT-TABELLEN - SAWING TABLES

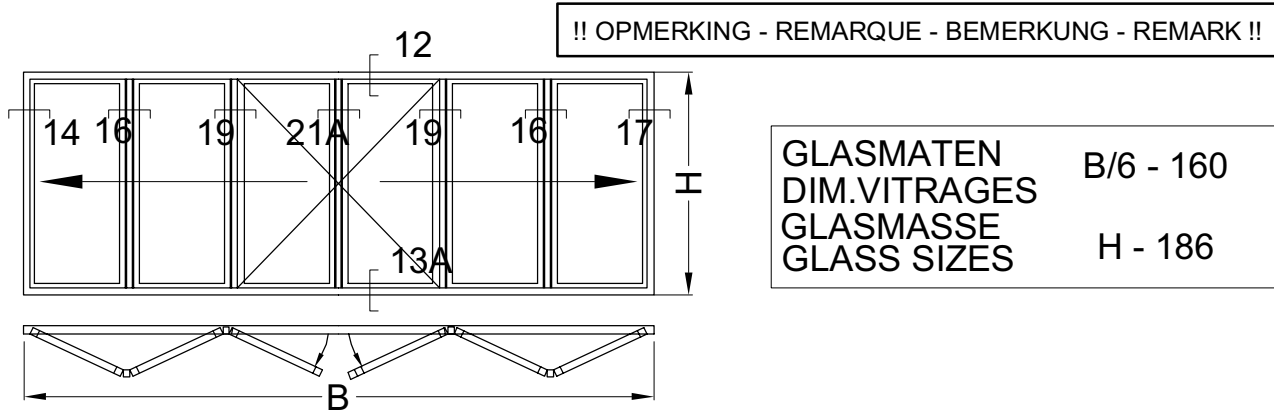

PROFIELEN PROFILES PROFILE PROFILS

DV10		2		B
DV10		2		H
DV21		12		B/6-55
DV21		12		H-80
DV31		5		H-80
VG53	n	2		B-90
VL6*	מדידתחמג	12		B/6-147
VL6*	מדידתחמג	12		H-216
DV52	א	1		H-80
DV52	א	1		H-110
VG52	ב	2		B-90
VG52	ב	4		H-90

TOEBEHOREN ACCESSOIRES ZUBEHORTEILE ACCESSORIES

ACDV12/13	4	ACDV214	2sets	ACVG45	2
ACDV14/15	4	ACDV326	1	ACDV205	2H+2B
ACDV10/11	48	ACDV313	2	ACDV202	40H
ACDV206	10	ACVL127	1set	ACDV203	11H+2B-1.3M
ACDV208	40	ACDV215	1	ACVG31	12H+2B-1.3M
ACDV209	2	ACDV725	1	ACVG3*	12H+2B-1.3M
ACDV210	2	ACDV118	3	ACMX309	1
ACFA211	2	ACVL020	28	ACFA120	2
ACDV212	2	ACVL057	48		
ACDV213	4	ACDV720	1		

zaagl028

DV211I7

MET VLAKKE DORPEL
AVEC SEUIL PLAT
MIT FLACHE SCHWELLE
WITH FLAT THRESHOLD

MET STANGENSLUITING
AVEC SERRURE A TRINGLE
MIT TREIBRIEGELSCHLOSS
WITH EXTENDED BOLT LOCK

ZAAGTABELLEN - TABLES DE SCIAGES - ZUSCHNITT-TABELLEN - SAWING TABLES

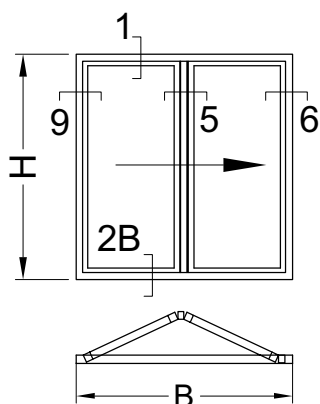

!! OPMERKING - REMARQUE - BEMERKUNG - REMARK !!

GLASMATEN B/2 - 204
DIM.VITRAGES
GLASMASSE
GLASS SIZES H - 188

PROFIELEN PROFILES PROFILE PROFILS

DV10		1		B
DV10		1		H
DV10		1		H
DV70		1		B-58
DV20		4		B/2 - 98.5
DV20		4		H-82
DV31		2		H-89
VG53		2		B-90
VL6*		4		B/2 - 190.5
VL6*		4		H-218
DV52		2		H-82
DV52		2		B/2 - 128.5
DV53		2		B/2 - 128.5
DV53		2		B/2 - 98.5
VG52		2		B-90
VG52		4		H-78

TOEBEHOREN ACCESSOIRES ZUBEHORTEILE ACCESSORIES

ACDV12/13	2	ACDV213	2	ACDV205	2H+1B
ACDV14/15	2	ACDV214	1set	ACDV202	16H
ACDV10/11	16	ACDV219	2	ACDV203	5H+1B-1.3M
ACDV206	2	ACVL020	10	ACVG31	4H+2B-1.3M
ACDV208	16	ACVL057	16	ACVG3*	4H+2B-1.3M
ACDV209	1	ACDR050	4	ACDV201	2B
ACDV210	1	ACVG45	2	ACVS010	2B-116
ACFA211	1				
ACDV212	1				

zaag1046

Type 3i (Chacal: DV419I7)

MET VLAKKE DORPEL
AVEC SEUIL PLAT
MIT FLACHE SCHWELLE
WITH FLAT THRESHOLDMET STANGENSLUITING
AVEC SERRURE A TRINGLE
MIT TREIBRIEGELSCHLOSS
WITH EXTENDED BOLT LOCK

ZAAGTABELLEN - TABLES DE SCIAGES - ZUSCHNITT-TABELLEN - SAWING TABLES

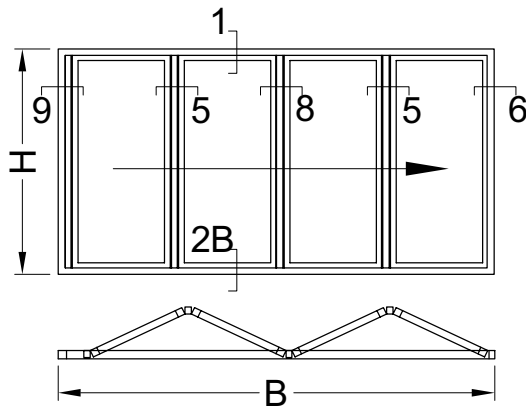

!! OPMERKING - REMARQUE - BEMERKUNG - REMARK !!

GLASMATEN	B/4 - 180
DIM.VITRAGES	
GLASMASSE	H - 188
GLASS SIZES	

PROFIELEN PROFILES PROFILE PROFILS

DV10		1		B
DV10		1		H
DV10		1		H
DV70		1		B-58
DV20		8		B/4 -74
DV20		8		H-82
DV31		4		H-89
VG53		2		B-90
VL6*		8		B/4 -166
VL6*		8		H-218
DV52		2		H-82
DV52		4		B/4-104
DV53		4		B/4-104
DV53		4		B/4-74
VG52		2		B-90
VG52		4		H-78

TOEBEHOREN ACCESSOIRES ZUBEHORTEILE ACCESSORIES

ACDV12/13	2	ACDV213	4	ACDV205	2H+1B
ACDV14/15	2	ACDV214	2sets	ACDV202	32H
ACDV10/11	32	ACDV219	4	ACDV203	9H+1B-1.3M
ACDV206	4	ACVL020	18	ACVG31	8H+2B-1.3M
ACDV208	32	ACVL057	32	ACVG3*	8H+2B-1.3M
ACDV209	2	ACDR050	4	ACDV201	2B
ACDV210	2	ACVG45	4	ACVS010	2B-116
ACFA211	2				
ACDV212	2				

zaag1031

Type 5i (Chacal: DV423I7)

MET VLAKKE DORPEL
AVEC SEUIL PLAT
MIT FLACHE SCHWELLE
WITH FLAT THRESHOLD

MET STANGENSLUITING
AVEC SERRURE A TRINGLE
MIT TREIBRIEGELSCHLOSS
WITH EXTENDED BOLT LOCK

ZAAGTABELLEN - TABLES DE SCIAGES - ZUSCHNITT-TABELLEN - SAWING TABLES

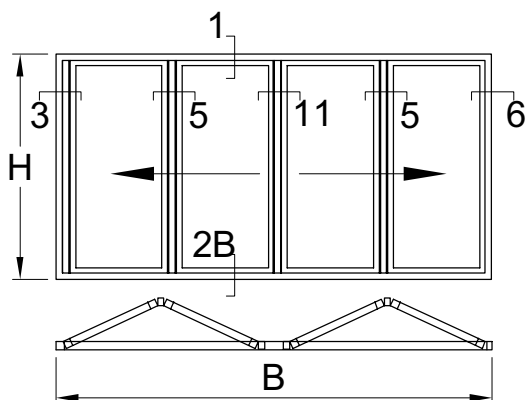

!! OPMERKING - REMARQUE - BEMERKUNG - REMARK !!

GLASMATEN
DIM.VITRAGES
GLASMASSE
GLASS SIZES

B/4 - 180
H - 188

PROFIELEN PROFILES PROFILE PROFILS

DV10		1		B
DV10		1		H
DV10		1		H
DV70		1		B-58
DV20		8		B/4 -74
DV20		8		H-82
DV31		4		H-89
VG53		2		B-90
VL6*		8		B/4 -166
VL6*		8		H-218
DV52		2		H-82
DV52		4		B/4-104
DV53		4		B/4-104
DV53		4		B/4-74
VG52		2		B-90
VG52		4		H-78

TOEBEHOREN ACCESSOIRES ZUBEHORTEILE ACCESSORIES

ACDV12/13	2	ACDV213	4	ACDV205	2H+1B
ACDV14/15	2	ACDV214	2sets	ACDV202	32H
ACDV10/11	32	ACDV219	4	ACDV203	8H+1B-1.3M
ACDV206	4	ACVL020	18	ACVG31	8H+2B-1.3M
ACDV208	32	ACVL057	32	ACVG3*	8H+2B-1.3M
ACDV209	2	ACDR050	4	ACDV201	2B
ACDV210	2	ACVG45	2	ACVS010	2B-116
ACFA211	2				
ACDV212	2				

zaag1033

Type 1i (Chacal: DV319I7)

MET VLAKKE DORPEL
AVEC SEUIL PLAT
MIT FLACHE SCHWELLE
WITH FLAT THRESHOLDMET CILINDERSLOT
AVEC SERRURE A CYLINDRE
MIT ZYLINDERSCHLOSS
WITH SECURITY LOCK

ZAAGTABELLEN - TABLES DE SCIAGES - ZUSCHNITT-TABELLEN - SAWING TABLES

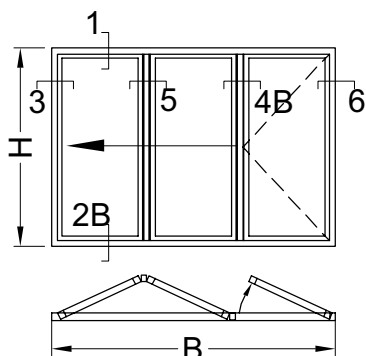

!! OPMERKING - REMARQUE - BEMERKUNG - REMARK !!

GLASMATEN	B/3 - 170
DIM. VITRAGES	
GLASMASSE	H - 188
GLASS SIZES	

PROFIELEN PROFILES PROFILE PROFILS

DV10		1		B
DV10		1		H
DV10		1		H
DV70		1		B-58
DV20		6		B/3 -64
DV20		6		H-82
DV31		2		H-89
VG53		2		B-90
VL6*		6		B/3 -156
VL6*		6		H-218
DV52		1		H-82
DV52		1		H-97
DV52		2		B/3-94
DV52		1		B/3-79
DV53		2		B/3-94
DV53		1		B/3-79
DV53		2		B/3-64
DV53		1		B/3-49
VG52		2		B-90
VG52		4		H-78

TOEBEHOREN ACCESSOIRES ZUBEHORTEILE ACCESSORIES

ACDV12/13	2	ACDV214	1set	ACDV205	2H+2B
ACDV14/15	2	ACVL020	14	ACDV202	20H
ACDV10/11	24	ACVL057	24	ACDV203	6H+1B-1M
ACDV206	2	ACDR050	4	ACVG31	6H+2B-1M
ACDV208	20	ACDV720	1	ACVG3*	6H+2B-1M
ACDV209	1	ACDV725	1	ACMX309	1
ACDV210	1	ACDV118	3	ACFA120	2
ACFA211	1	ACDV215	1	ACDV201	2B
ACDV212	1	ACDV219	2	ACVS010	2B-116
ACDV213	2	ACVG45	2		

zaagl029

Type 2i (Chacal: DV323I7)

MET VLAKKE DORPEL
AVEC SEUIL PLAT
MIT FLACHE SCHWELLE
WITH FLAT THRESHOLD

MET CILINDERSLOT
AVEC SERRURE A CYLINDRE
MIT ZYLINDERSCHLOSS
WITH SECURITY LOCK

ZAAGTABELLEN - TABLES DE SCIAGES - ZUSCHNITT-TABELLEN - SAWING TABLES

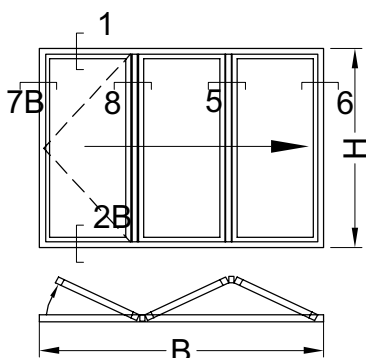

!! OPMERKING - REMARQUE - BEMERKUNG - REMARK !!

GLASMATEN	B/3 - 170
DIM.VITRAGES	
GLASMASSE	H - 188
GLASS SIZES	

PROFIELEN PROFILES PROFILE PROFILS

DV10		1		B
DV10		1		H
DV10		1		H
DV70		1		B-58
DV20		6		B/3 -64
DV20		6		H-82
DV31		2		H-89
VG53	n	2		B-90
VL6*	מדידת	6		B/3 -156
VL6*	מדידת	6		H-218
DV52	א	1		H-82
DV52	א	1		H-97
DV52	א	2		B/3-94
DV52	א	1		B/3-79
DV53	א	2		B/3-94
DV53	א	1		B/3-79
DV53	א	2		B/3-64
DV53	א	1		B/3-49
VG52	א	2		B-90
VG52	א	4		H-78

TOEBEHOREN ACCESSOIRES ZUBEHORTEILE ACCESSORIES

ACDV12/13	2	ACDV213	2	ACDV219	2
ACDV14/15	2	ACDV214	1set	ACDV205	2H+2B
ACDV10/11	24	ACVL020	14	ACDV202	20H
ACDV206	2	ACVL057	24	ACDV203	6H+1B-1M
ACDV208	20	ACDR050	4	ACVG31	6H+2B-1M
ACDV209	1	ACDV720	1	ACVG3*	6H+2B-1M
ACDV210	1	ACDV725	1	ACMX309	1
ACFA211	1	ACDV117	3	ACFA120	2
ACDV212	1	ACDV215	1	ACDV201	2B
		ACVG45	2	ACVS010	2B-116

zaagI030

Type 4i (Chacal: DV415I7)

MET VLAKKE DORPEL
AVEC SEUIL PLAT
MIT FLACHE SCHWELLE
WITH FLAT THRESHOLDMET CILINDERSLOT
AVEC SERRURE A CYLINDRE
MIT ZYLINDERSCHLOSS
WITH SECURITY LOCK

ZAAGTABELLEN - TABLES DE SCIAGES - ZUSCHNITT-TABELLEN - SAWING TABLES

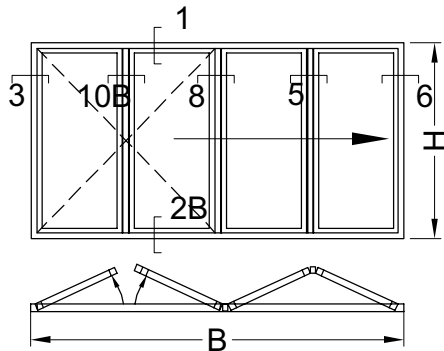

!! OPMERKING - REMARQUE - BEMERKUNG - REMARK !!

GLASMATEN	B/4 - 164
DIM.VITRAGES	
GLASMASSE	H - 188
GLASS SIZES	

PROFIELEN PROFILES PROFILE PROFILS

DV10		1		B
DV10		1		H
DV10		1		H
DV70		1		B-58
DV20		8		B/4-58
DV20		8		H-82
DV31		3		H-89
VG53		2		B-90
VL6*		8		B/4-150
VL6*		8		H-218
DV52		1		H-82
DV52		1		H-97
DV52		3		B/4-88
DV52		1		B/4-73
DV53		3		B/4-88
DV53		1		B/4-73
DV53		3		B/4-58
DV53		1		B/4-43
VG52		2		B-90
VG52		4		H-78

TOEBEHOREN ACCESSOIRES ZUBEHÖRTEILE ACCESSORIES

ACDV12/13	2	ACDV326	1	ACDV201	2B
ACDV14/15	2	ACDV313	2	ACDV205	2H+1B
ACDV10/11	32	ACVL127	1set	ACDV202	24H
ACDV206	3	ACVL020	18	ACDV203	7H+1B-1.3M
ACDV208	24	ACVL057	32	ACVG31	8H+2B-1.3M
ACDV209	1	ACDR050	4	ACVG3*	8H+2B-1.3M
ACDV210	1	ACDV720	1	ACMX309	1
ACFA211	1	ACDV725	1	ACFA120	2
ACDV212	1	ACDV118	3	ACVS010	2B-116
ACDV213	2	ACDV215	1		
ACDV214	1set	ACDV219	3		

zaagl032

Type 6i variant (Chacal: DV519I7)

MET VLAKKE DORPEL
AVEC SEUIL PLAT
MIT FLACHE SCHWELLE
WITH FLAT THRESHOLD

MET CILINDERSLOT
AVEC SERRURE A CYLINDRE
MIT ZYLINDERSCHLOSS
WITH SECURITY LOCK

ZAAGTABELLEN - TABLES DE SCIAGES - ZUSCHNITT-TABELLEN - SAWING TABLES

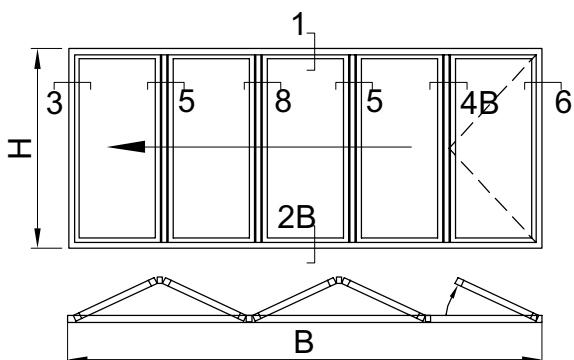

!! OPMERKING - REMARQUE - BEMERKUNG - REMARK !!

GLASMATEN DIM. VITRAGES B/5 - 164
GLASMASSE GLASS SIZES H - 188

PROFIELEN PROFILES PROFILE PROFILS

DV10		1		B
DV10		1		H
DV10		1		H
DV70		1		B-58
DV20		10		B/5-58
DV20		10		H-82
DV31		4		H-89
VG53	n	2		B-90
VL6*	מדידת	10		B/5-150
VL6*	מדידת	10		H-218
DV52	ח	1		H-82
DV52	ח	1		H-97
DV52	ח	4		B/5-88
DV52	ח	1		B/5-73
DV53	ח	4		B/5-88
DV53	ח	1		B/5-73
DV53	ח	4		B/5-58
DV53	ח	1		B/5-43
VG52	ח	2		B-90
VG52	ח	4		H-78

TOEBEHOREN ACCESSOIRES ZUBEHORTEILE ACCESSORIES

ACDV12/13	2	ACDV213	4	ACDV219	4
ACDV14/15	2	ACDV214	2sets	ACDV205	2H+1B
ACDV10/11	40	ACVL020	22	ACDV202	36H
ACDV206	4	ACVL057	40	ACDV203	10H+1B-1M
ACDV208	36	ACDR050	4	ACVG31	10H+2B-1M
ACDV209	2	ACDV720	1	ACVG3*	10H+2B-1M
ACDV210	2	ACDV725	1	ACMX309	1
ACFA211	2	ACDV118	3	ACFA120	2
ACDV212	2	ACDV215	1	ACDV201	2B
		ACVG45	2	ACVS010	2B-116

zaagI034

Type 6i (Chacal: DV523I7)

MET VLAKKE DORPEL
AVEC SEUIL PLAT
MIT FLACHE SCHWELLE
WITH FLAT THRESHOLDMET CILINDERSLOT
AVEC SERRURE A CYLINDRE
MIT ZYLINDERSCHLOSS
WITH SECURITY LOCK

ZAAGTABELLEN - TABLES DE SCIAGES - ZUSCHNITT-TABELLEN - SAWING TABLES

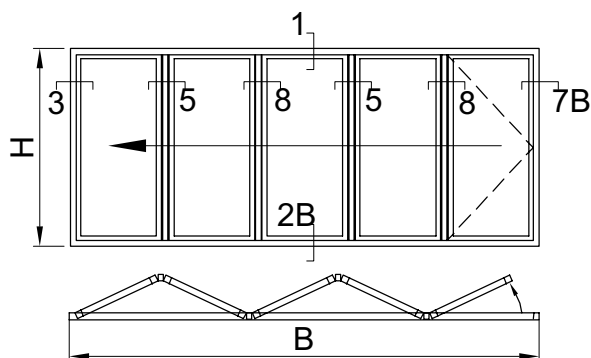

!! OPMERKING - REMARQUE - BEMERKUNG - REMARK !!

GLASMATEN	B/5 - 164
DIM.VITRAGES	
GLASMASSE	H - 188
GLASS SIZES	

PROFIELEN PROFILES PROFILE PROFILS

DV10		1		B
DV10		1		H
DV10		1		H
DV70		1		B-58
DV20		10		B/5-58
DV20		10		H-82
DV31		4		H-89
VG53		2		B-90
VL6*		10		B/5-150
VL6*		10		H-218
DV52		1		H-82
DV52		1		H-97
DV52		4		B/5-88
DV52		1		B/5-73
DV53		4		B/5-88
DV53		1		B/5-73
DV53		4		B/5-58
DV53		1		B/5-43
VG52		2		B-90
VG52		4		H-78

TOEBEHOREN ACCESSOIRES ZUBEHORTEILE ACCESSORIES

ACDV12/13	2	ACDV213	4	ACDV219	4
ACDV14/15	2	ACDV214	2sets	ACDV205	2H+1B
ACDV10/11	40	ACVL020	22	ACDV202	36H
ACDV206	4	ACVL057	40	ACDV203	10H+1B-1M
ACDV208	36	ACDR050	4	ACVG31	10H+2B-1M
ACDV209	2	ACDV720	1	ACVG3*	10H+2B-1M
ACDV210	2	ACDV725	1	ACMX309	1
ACFA211	2	ACDV117	3	ACFA120	2
ACDV212	2	ACDV215	1	ACDV201	2B
		ACVG45	2	ACVS010	2B-116

zaagl035

Type 7i (Chacal: DV623I7)

MET VLAKKE DORPEL
AVEC SEUIL PLAT
MIT FLACHE SCHWELLE
WITH FLAT THRESHOLD

MET CILINDERSLOT
AVEC SERRURE A CYLINDRE
MIT ZYLINDERSCHLOSS
WITH SECURITY LOCK

ZAAGTABELLEN - TABLES DE SCIAGES - ZUSCHNITT-TABELLEN - SAWING TABLES

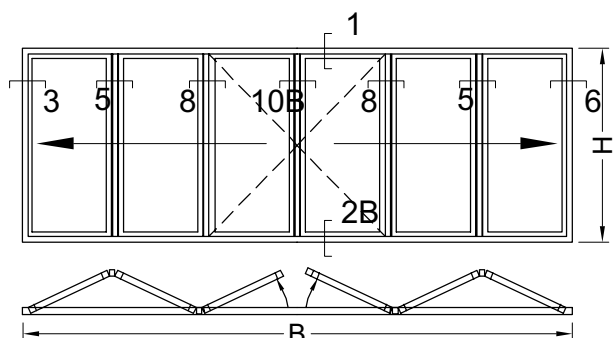

!! OPMERKING - REMARQUE - BEMERKUNG - REMARK !!

GLASMATEN	B/6 - 160
DIM.VITRAGES	
GLASMASSE	H - 188
GLASS SIZES	

PROFIELEN PROFILES PROFILE PROFILS

DV10		1		B
DV10		1		H
DV10		1		H
DV70		1		B-58
DV20		12		B/6-55
DV20		12		H-82
DV31		5		H-89
VG53		2		B-90
VL6*		12		B/6-147
VL6*		12		H-218
DV52		1		H-82
DV52		1		H-97
DV52		5		B/6-85
DV52		1		B/6-70
DV53		5		B/6-85
DV53		1		B/6-70
DV53		5		B/6-55
DV53		1		B/6-40
VG52		2		B-90
VG52		4		H-78

TOEBEHOREN ACCESSOIRES ZUBEHORTEILE ACCESSORIES

ACDV12/13	2	ACDV326	1	ACDV219	5
ACDV14/15	2	ACDV313	2	ACDV205	2H+1B
ACDV10/11	48	ACVL127	1set	ACDV202	40H
ACDV206	5	ACVL020	26	ACDV203	11H+1B-1.3M
ACDV208	40	ACVL057	48	ACVG31	12H+2B-1.3M
ACDV209	2	ACDR050	4	ACVG3*	12H+2B-1.3M
ACDV210	2	ACDV720	1	ACMX309	1
ACFA211	2	ACDV725	1	ACFA120	2
ACDV212	2	ACDV118	3	ACDV201	2B
ACDV213	4	ACDV215	1	ACVS010	2B-116
ACDV214	2sets	ACVG45	2		

zaag036

DV213E7

MET VLAKKE DORPEL
AVEC SEUIL PLAT
MIT FLACHE SCHWELLE
WITH FLAT THRESHOLD

MET STANGENSLUITING
AVEC SERRURE A TRINGLE
MIT TREIBRIEGELSCHLOSS
WITH EXTENDED BOLT LOCK

ZAAGTABELLEN - TABLES DE SCIAGES - ZUSCHNITT-TABELLEN - SAWING TABLES

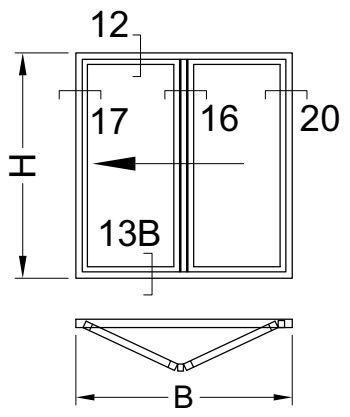

!! OPMERKING - REMARQUE - BEMERKUNG - REMARK !!

GLASMATEN B/2 - 204
DIM.VITRAGES
GLASMASSE H - 188
GLASS SIZES

PROFIELEN PROFILES PROFILE PROFILS

DV10		1		B
DV10		1		H
DV10		1		H
DV70		1		B-58
DV21		4		B/2 - 98.5
DV21		4		H-82
DV31		2		H-89
VG53		2		B-90
VL6*		4		B/2 - 190.5
VL6*		4		H-218
DV52		2		H-82
DV52		2		B/2 - 128.5
DV53		2		B/2 - 128.5
DV53		2		B/2 - 98.5
VG52		2		B-90
VG52		4		H-78

TOEBEHOREN ACCESSOIRES ZUBEHORTEILE ACCESSORIES

ACDV12/13	2	ACDV213	2	ACDV205	2H+1B
ACDV14/15	2	ACDV214	1set	ACDV202	16H
ACDV10/11	16	ACDV219	2	ACDV203	5H+1B-1.3M
ACDV206	2	ACVL020	10	ACVG31	4H+2B-1.3M
ACDV208	16	ACVL057	16	ACVG3*	4H+2B-1.3M
ACDV209	1	ACDR050	4	ACDV201	2B
ACDV210	1	ACVG45	2	ACVS010	2B-116
ACFA211	1				
ACDV212	1				

zaag1048

Type 3e (Chacal: DV421E7)

MET VLAKE DORPEL
AVEC SEUIL PLAT
MIT FLACHE SCHWELLE
WITH FLAT THRESHOLD

MET STANGENSLUITING
AVEC SERRURE A TRINGLE
MIT TREIBRIEGELSCHLOSS
WITH EXTENDED BOLT LOCK

ZAAGTABELLEN - TABLES DE SCIAGES - ZUSCHNITT-TABELLEN - SAWING TABLES

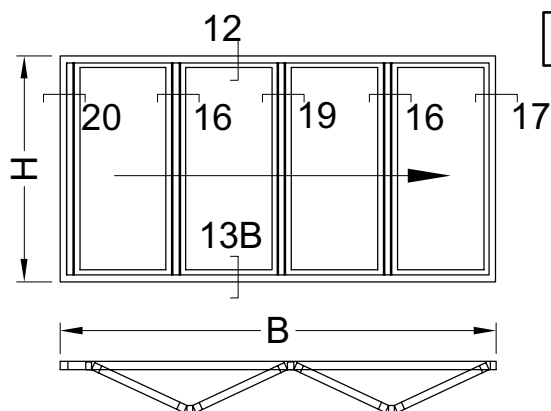

!! OPMERKING - REMARQUE - BEMERKUNG - REMARK !!

GLASMATEN B/4 - 180
DIM.VITRAGES
GLASMASSE H - 188
GLASS SIZES

PROFIELEN PROFILES PROFILE PROFILS

DV10		1		B
DV10		1		H
DV10		1		H
DV70		1		B-58
DV21		8		B/4 -74
DV21		8		H-82
DV31		4		H-89
VG53	n	2		B-90
VL6*	מדידתחמג	8		B/4 -166
VL6*	מדידתחמג	8		H-218
DV52	ח	2		H-82
DV52	ח	4		B/4-104
DV53	ח	4		B/4-104
DV53	ח	4		B/4-74
VG52	ח	2		B-90
VG52	ח	4		H-78

TOEBEHOREN ACCESSOIRES ZUBEHORTEILE ACCESSORIES

ACDV12/13	2	ACDV213	4	ACDV205	2H+1B
ACDV14/15	2	ACDV214	2sets	ACDV202	32H
ACDV10/11	32	ACDV219	4	ACDV203	9H+1B-1.3M
ACDV206	4	ACVL020	18	ACVG31	8H+2B-1.3M
ACDV208	32	ACVL057	32	ACVG3*	8H+2B-1.3M
ACDV209	2	ACDR050	4	ACDV201	2B
ACDV210	2	ACVG45	2	ACVS010	2B-116
ACFA211	2				
ACDV212	2				

zaag1039

Type 1e (Chacal: DV321E7)

MET VLAKKE DORPEL
AVEC SEUIL PLAT
MIT FLACHE SCHWELLE
WITH FLAT THRESHOLDMET CILINDERSLOT
AVEC SERRURE A CYLINDRE
MIT ZYLINDERSCHLOSS
WITH SECURITY LOCK

ZAAGTABELLEN - TABLES DE SCIAGES - ZUSCHNITT-TABELLEN - SAWING TABLES

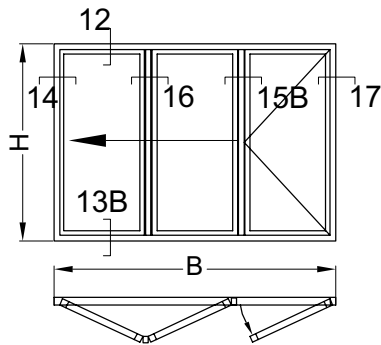

!! OPMERKING - REMARQUE - BEMERKUNG - REMARK !!

GLASMATEN	B/3 - 170
DIM.VITRAGES	
GLASMASSE	H - 188
GLASS SIZES	

PROFIELEN PROFILES PROFILE PROFILS

DV10		1		B
DV10		1		H
DV10		1		H
DV70		1		B-58
DV21		6		B/3 -64
DV21		6		H-82
DV31		2		H-89
VG53		2		B-90
VL6*	מדידת	6		B/3 -156
VL6*	מדידת	6		H-218
DV52		1		H-82
DV52		2		B/3-94
DV52		1		H-97
DV52		1		B/3-79
DV53		2		B/3-94
DV53		1		B/3-79
DV53		2		B/3-64
DV53		1		B/3-49
VG52		2		B-90
VG52		4		H-78

TOEBEHOREN ACCESSOIRES ZUBEHORTEILE ACCESSORIES

ACDV12/13	2	ACDV213	2	ACDV219	2
ACDV14/15	2	ACDV214	1set	ACDV205	2H+1B
ACDV10/11	24	ACVL020	14	ACDV202	20H
ACDV206	2	ACVL057	24	ACDV203	6H+1B-1M
ACDV208	20	ACDR050	4	ACVG31	6H+2B-1M
ACDV209	1	ACDV720	1	ACVG3*	6H+2B-1M
ACDV210	1	ACDV725	1	ACMX309	1
ACFA211	1	ACDV118	3	ACFA120	2
ACDV212	1	ACDV215	1	ACDV201	2B
		ACVG45	2	ACVS010	2B-116

zaagl037

Type 2e (Chacal: DV325E7)

MET VLAKKE DORPEL
AVEC SEUIL PLAT
MIT FLACHE SCHWELLE
WITH FLAT THRESHOLD

MET CILINDERSLOT
AVEC SERRURE A CYLINDRE
MIT ZYLINDERSCHLOSS
WITH SECURITY LOCK

ZAAGTABELLEN - TABLES DE SCIAGES - ZUSCHNITT-TABELLEN - SAWING TABLES

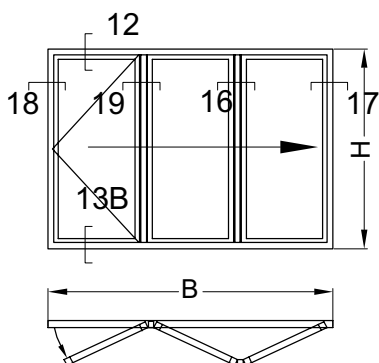

!! OPMERKING - REMARQUE - BEMERKUNG - REMARK !!

GLASMATEN B/3 - 170
DIM.VITRAGES
GLASMASSE H - 188
GLASS SIZES

PROFIELEN PROFILES PROFILE PROFILS

DV10		1		B
DV10		1		H
DV10		1		H
DV70		1		B-58
DV21		6		B/3 -64
DV21		6		H-82
DV31		2		H-89
VG53		2		B-90
VL6*		6		B/3 -156
VL6*		6		H-218
DV52		1		H-82
DV52		1		H-97
DV52		2		B/3-94
DV52		1		B/3-79
DV53		2		B/3-94
DV53		1		B/3-79
DV53		2		B/3-64
DV53		1		B/3-49
VG52		2		B-90
VG52		4		H-78

TOEBEHOREN ACCESSOIRES ZUBEHORTEILE ACCESSORIES

ACDV12/13	2	ACDV213	2	ACDV219	2
ACDV14/15	2	ACDV214	1set	ACDV205	2H+1B
ACDV10/11	24	ACVL020	14	ACDV202	20H
ACDV206	2	ACVL057	24	ACDV203	6H+1B-1M
ACDV208	20	ACDR050	4	ACVG31	6H+2B-1M
ACDV209	1	ACDV720	1	ACVG3*	6H+2B-1M
ACDV210	1	ACDV725	1	ACMX309	1
ACFA211	1	ACDV117	3	ACFA120	2
ACDV212	1	ACDV215	1	ACDV201	2B
		ACVG45	2	ACVS010	2B-116

zaagl038

Type 4e (Chacal: DV417E7)

MET VLAKKE DORPEL
AVEC SEUIL PLAT
MIT FLACHE SCHWELLE
WITH FLAT THRESHOLDMET CILINDERSLOT
AVEC SERRURE A CYLINDRE
MIT ZYLINDERSCHLOSS
WITH SECURITY LOCK

ZAAGTABELLEN - TABLES DE SCIAGES - ZUSCHNITT-TABELLEN - SAWING TABLES

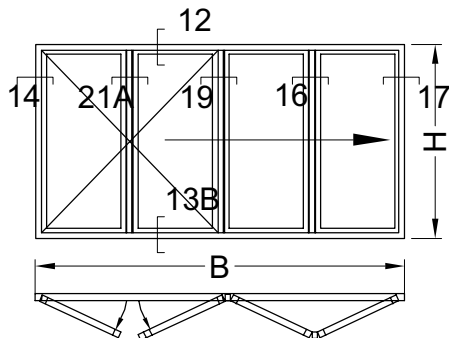

!! OPMERKING - REMARQUE - BEMERKUNG - REMARK !!

GLASMATEN	B/4 - 164
DIM.VITRAGES	
GLASMASSE	H - 188
GLASS SIZES	

PROFIELEN PROFILES PROFILE PROFILS

DV10		1		B
DV10		1		H
DV10		1		H
DV70		1		B-58
DV21		8		B/4-58
DV21		8		H-82
DV31		3		H-89
VG53		2		B-90
VL6*		8		B/4-150
VL6*		8		H-218
DV52		1		H-82
DV52		1		H-97
DV52		3		B/4-88
DV52		1		B/4-73
DV53		3		B/4-88
DV53		1		B/4-73
DV53		3		B/4-58
DV53		1		B/4-43
VG52		2		B-90
VG52		4		H-78

TOEBEHOREN ACCESSOIRES ZUBEHÖRTEILE ACCESSORIES

ACDV12/13	2	ACDV326	1	ACVG45	2
ACDV14/15	2	ACDV313	2	ACDV205	2H+1B
ACDV10/11	32	ACVL127	1set	ACDV202	24H
ACDV206	3	ACVL020	18	ACDV203	7H+1B-1.3M
ACDV208	24	ACVL057	32	ACVG31	8H+2B-1.3M
ACDV209	1	ACDR050	4	ACVG3*	8H+2B-1.3M
ACDV210	1	ACDV720	1	ACMX309	1
ACFA211	1	ACDV725	1	ACFA120	2
ACDV212	1	ACDV118	3	ACVS010	2B-116
ACDV213	2	ACDV215	1	ACDV201	2B
ACDV214	1set	ACDV219	3		

zaagl040

Type 5e (Chacal: DV425E7)

MET VLAKE DORPEL
AVEC SEUIL PLAT
MIT FLACHE SCHWELLE
WITH FLAT THRESHOLD

MET CILINDERSLOT
AVEC SERRURE A CYLINDRE
MIT ZYLINDERSCHLOSS
WITH SECURITY LOCK

ZAAGTABELLEN - TABLES DE SCIAGES - ZUSCHNITT-TABELLEN - SAWING TABLES

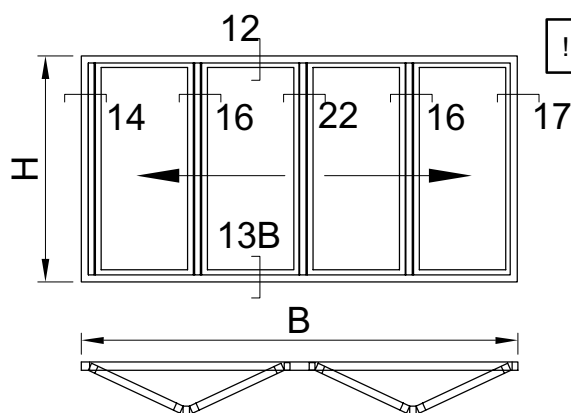

!! OPMERKING - REMARQUE - BEMERKUNG - REMARK !!

GLASMATEN
DIM.VITRAGES
GLASSMASSE
GLASS SIZES
B/4 - 180
H - 188

PROFIELEN PROFILES PROFILE PROFILS

DV10		1		B
DV10		1		H
DV10		1		H
DV70		1		B-58
DV21		8		B/4 -74
DV21		8		H-82
DV31		4		H-89
VG53	⌈	2		B-90
VL6*	מדידתחמג	8		B/4 -166
VL6*	מדידתחמג	8		H-218
DV52	⌈	2		H-82
DV52	⌈	4		B/4-104
DV53	⌈	4		B/4-104
DV53	⌈	4		B/4-74
VG52	⌈	2		B-90
VG52	⌈	4		H-78

TOEBEHOREN ACCESSOIRES ZUBEHORTEILE ACCESSORIES

ACDV12/13	2	ACDV213	4	ACDV205	2H+1B
ACDV14/15	2	ACDV214	2sets	ACDV202	32H
ACDV10/11	32	ACDV219	4	ACDV203	8H+1B-1.3M
ACDV206	4	ACVL020	18	ACVG31	8H+2B-1.3M
ACDV208	32	ACVL057	32	ACVG3*	8H+2B-1.3M
ACDV209	2	ACDR050	4	ACDV201	2B
ACDV210	2	ACVG45	2	ACVS010	2B-116
ACFA211	2				
ACDV212	2				

zaag041

Type 6e variant (Chacal: DV521E7)

MET VLAKKE DORPEL
AVEC SEUIL PLAT
MIT FLACHE SCHWELLE
WITH FLAT THRESHOLDMET CILINDERSLOT
AVEC SERRURE A CYLINDRE
MIT ZYLINDERSCHLOSS
WITH SECURITY LOCK

ZAAGTABELLEN - TABLES DE SCIAGES - ZUSCHNITT-TABELLEN - SAWING TABLES

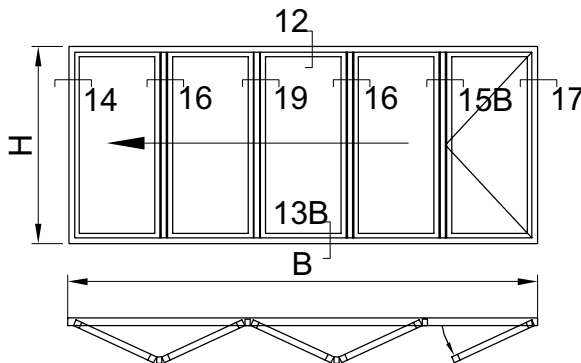

!! OPMERKING - REMARQUE - BEMERKUNG - REMARK !!

GLASMATEN DIM. VITRAGES GLASMASSE GLASS SIZES	B/5 - 164 H - 188
--	----------------------

PROFIELEN PROFILES PROFILE PROFILS

DV10		1		B
DV10		1		H
DV10		1		H
DV70		1		B-58
DV21		10		B/5-58
DV21		10		H-82
DV31		4		H-89
VG53		2		B-90
VL6*		10		B/5-150
VL6*		10		H-218
DV52		1		H-82
DV52		1		H-97
DV52		4		B/5-88
DV52		1		B/5-73
DV53		4		B/5-88
DV53		1		B/5-73
DV53		4		B/5-58
DV53		1		B/5-43
VG52		2		B-90
VG52		4		H-78

TOEBEHOREN ACCESSOIRES ZUBEHORTEILE ACCESSORIES

ACDV12/13	2	ACDV213	4	ACDV219	4
ACDV14/15	2	ACDV214	2sets	ACDV205	2H+1B
ACDV10/11	40	ACVL020	22	ACDV202	36H
ACDV206	4	ACVL057	40	ACDV203	10H+1B-1M
ACDV208	36	ACDR050	4	ACVG31	10H+2B-1M
ACDV209	2	ACDV720	1	ACVG3*	10H+2B-1M
ACDV210	2	ACDV725	1	ACMX309	1
ACFA211	2	ACDV118	3	ACFA120	2
ACDV212	2	ACDV215	1	ACDV201	2B
		ACVG45	2	ACVS010	2B-116

zaagl042

Type 6e (Chacal: DV525E7)

MET VLAKKE DORPEL
AVEC SEUIL PLAT
MIT FLACHE SCHWELLE
WITH FLAT THRESHOLD

MET CILINDERSLOT
AVEC SERRURE A CYLINDRE
MIT ZYLINDERSCHLOSS
WITH SECURITY LOCK

ZAAGTABELLEN - TABLES DE SCIAGES - ZUSCHNITT-TABELLEN - SAWING TABLES

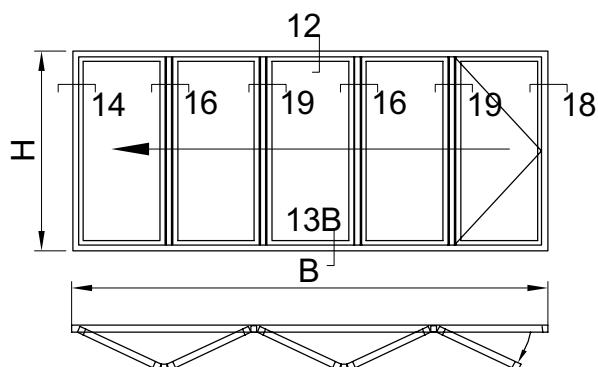

!! OPMERKING - REMARQUE - BEMERKUNG - REMARK !!

GLASMATEN DIM.VITRAGES B/5 - 164
GLASMASSE GLASS SIZES H - 188

PROFIELEN PROFILES PROFILE PROFILS

DV10		1		B
DV10		1		H
DV10		1		H
DV70		1		B-58
DV21		10		B/5-58
DV21		10		H-82
DV31		4		H-89
VG53		2		B-90
VL6*	מגדירות	10		B/5-150
VL6*	מגדירות	10		H-218
DV52		1		H-82
DV52		1		H-97
DV52		4		B/5-88
DV52		1		B/5-73
DV53		4		B/5-88
DV53		1		B/5-73
DV53		4		B/5-58
DV53		1		B/5-43
VG52		2		B-90
VG52		4		H-78

TOEBEHOREN ACCESSOIRES ZUBEHORTEILE ACCESSORIES

ACDV12/13	2	ACDV213	4	ACDV219	4
ACDV14/15	2	ACDV214	2sets	ACDV205	2H+1B
ACDV10/11	40	ACVL020	22	ACDV202	36H
ACDV206	4	ACVL057	40	ACDV203	10H+1B-1M
ACDV208	36	ACDR050	4	ACVG31	10H+2B-1M
ACDV209	2	ACDV720	1	ACVG3*	10H+2B-1M
ACDV210	2	ACDV725	1	ACMX309	1
ACFA211	2	ACDV117	3	ACFA120	2
ACDV212	2	ACDV215	1	ACDV201	2B
		ACVG45	2	ACVS010	2B-116

zaagl043

Type 7e (Chacal: DV625E7)

MET VLAKKE DORPEL
AVEC SEUIL PLAT
MIT FLACHE SCHWELLE
WITH FLAT THRESHOLDMET CILINDERSLOT
AVEC SERRURE A CYLINDRE
MIT ZYLINDERSCHLOSS
WITH SECURITY LOCK

ZAAGTABELLEN - TABLES DE SCIAGES - ZUSCHNITT-TABELLEN - SAWING TABLES

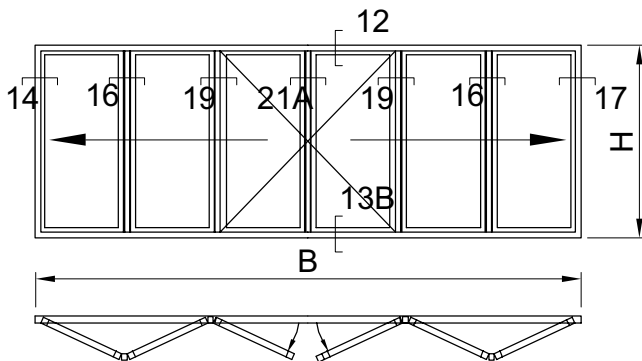

!! OPMERKING - REMARQUE - BEMERKUNG - REMARK !!

GLASMATEN	B/6 - 160
DIM.VITRAGES	
GLASMASSE	H - 188
GLASS SIZES	

PROFIELEN PROFILES PROFILE PROFILS

DV10		1		B
DV10		1		H
DV10		1		H
DV70		1		B-58
DV21		12		B/6-55
DV21		12		H-82
DV31		5		H-89
VG53		2		B-90
VL6*		12		B/6-147
VL6*		12		H-218
DV52		1		H-82
DV52		1		H-97
DV52		5		B/6-85
DV52		1		B/6-70
DV53		5		B/6-85
DV53		1		B/6-70
DV53		5		B/6-55
DV53		1		B/6-40
VG52		2		B-90
VG52		4		H-78

TOEBEHOREN ACCESSOIRES ZUBEHORTEILE ACCESSORIES

ACDV12/13	2	ACDV326	1	ACDV219	5
ACDV14/15	2	ACDV313	2	ACDV205	2H+1B
ACDV10/11	48	ACVL127	1set	ACDV202	40H
ACDV206	5	ACVL020	26	ACDV203	11H+1B-1.3M
ACDV208	40	ACVL057	48	ACVG31	12H+2B-1.3M
ACDV209	2	ACDR050	4	ACVG3*	12H+2B-1.3M
ACDV210	2	ACDV720	1	ACMX309	1
ACFA211	2	ACDV725	1	ACFA120	2
ACDV212	2	ACDV118	3	ACDV201	2B
ACDV213	4	ACDV215	1	ACVS010	2B-116
ACDV214	2sets	ACVG45	2		

zaagl044

OPSPIEEN VAN HET GLAS
CALLAGE DU VITRAGE
VERKLOTZUNGS HINWEISE
CALIBRATION OF THE GLASS

WERKTEKENINGEN - DESSINS DE CONSTRUCTION - KONSTRUKTIONZEICHNUNGEN - CONSTRUCTION DRAWING

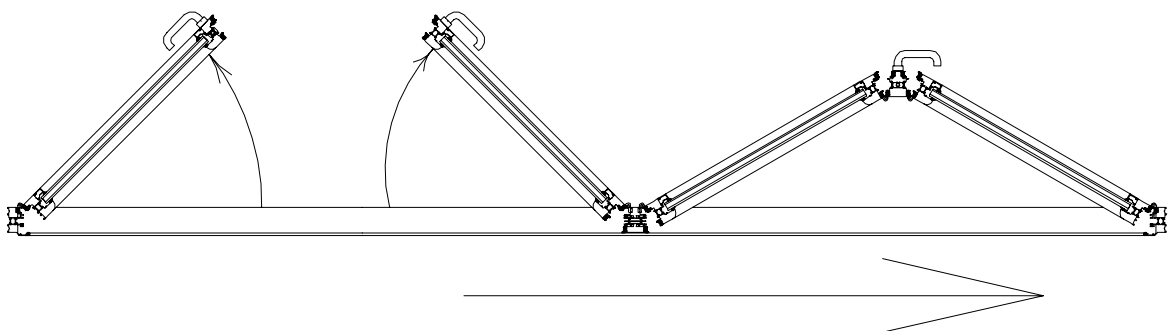
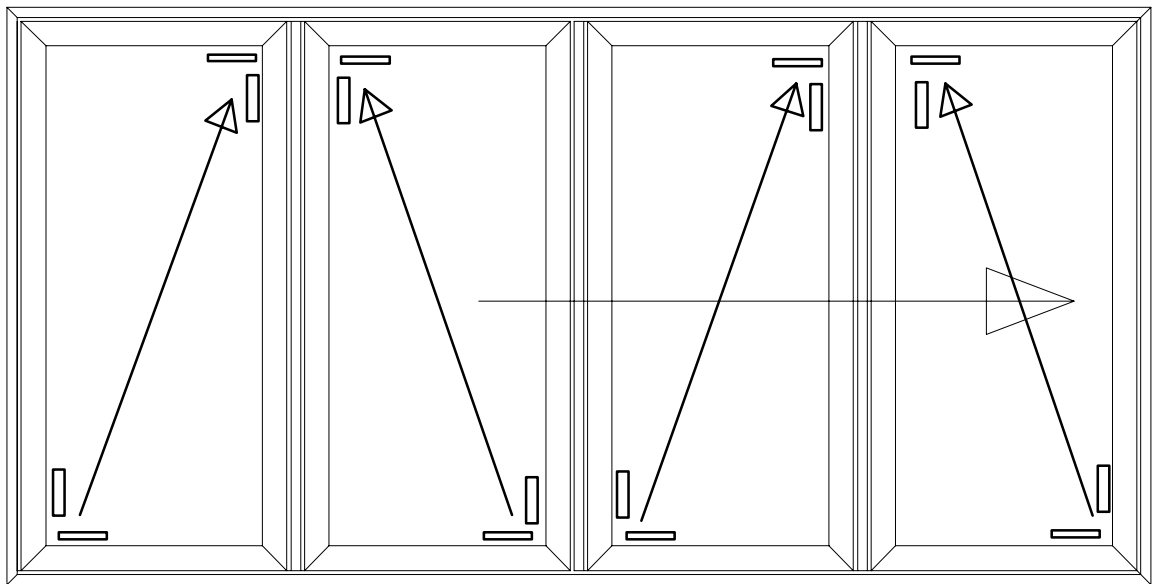

werkt01

MONTAGE ACDV209 EN ACDV206 IN DV31
MONTAGE ACDV209 ET ACDV206 DANS DV31
MONTAGE ACDV209 UND ACDV206 IN DV31
MONTAGE ACDV209 AND ACDV206 IN DV31

WERKTEKENINGEN - DESSINS DE CONSTRUCTION - KONSTRUKTIONZEICHNUNGEN - CONSTRUCTION DRAWING

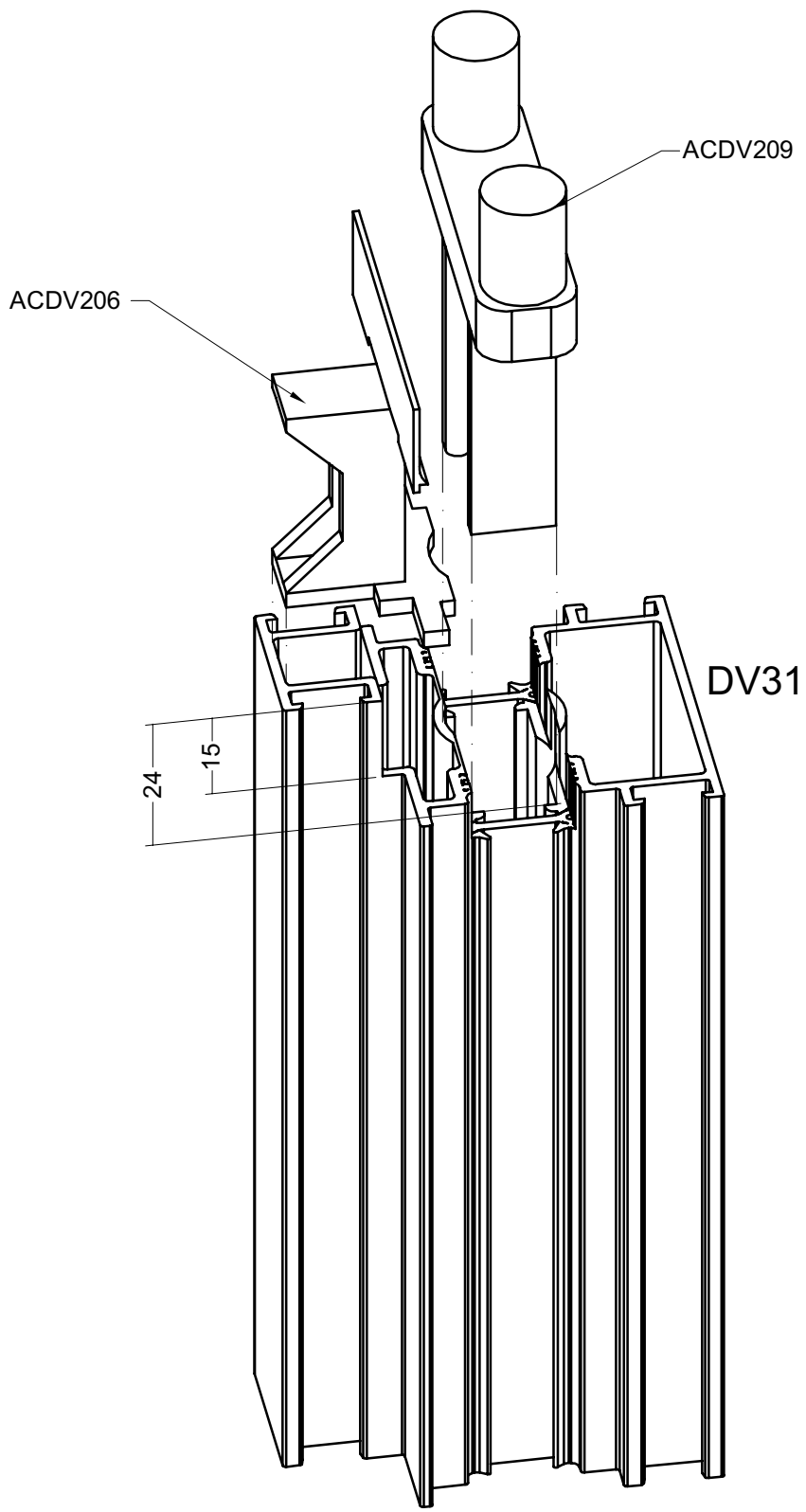

werkt04

MONTAGE ACDV209 EN ACDV206 IN DV31 VOOR DV10
MONTAGE ACDV209 ET ACDV206 DANS DV31 POUR DV10
MONTAGE ACDV209 UND ACDV206 IN DV31 FÜR DV10
MONTAGE ACDV209 AND ACDV206 IN DV31 FOR DV10

WERKTEKENINGEN - DESSINS DE CONSTRUCTION - KONSTRUKTIONZEICHNUNGEN - CONSTRUCTION DRAWING

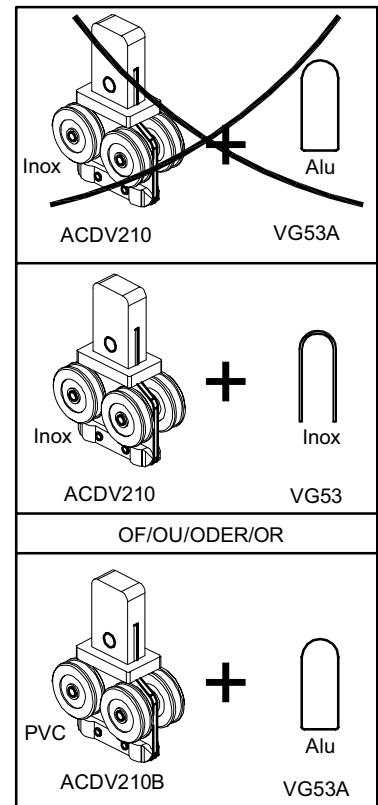
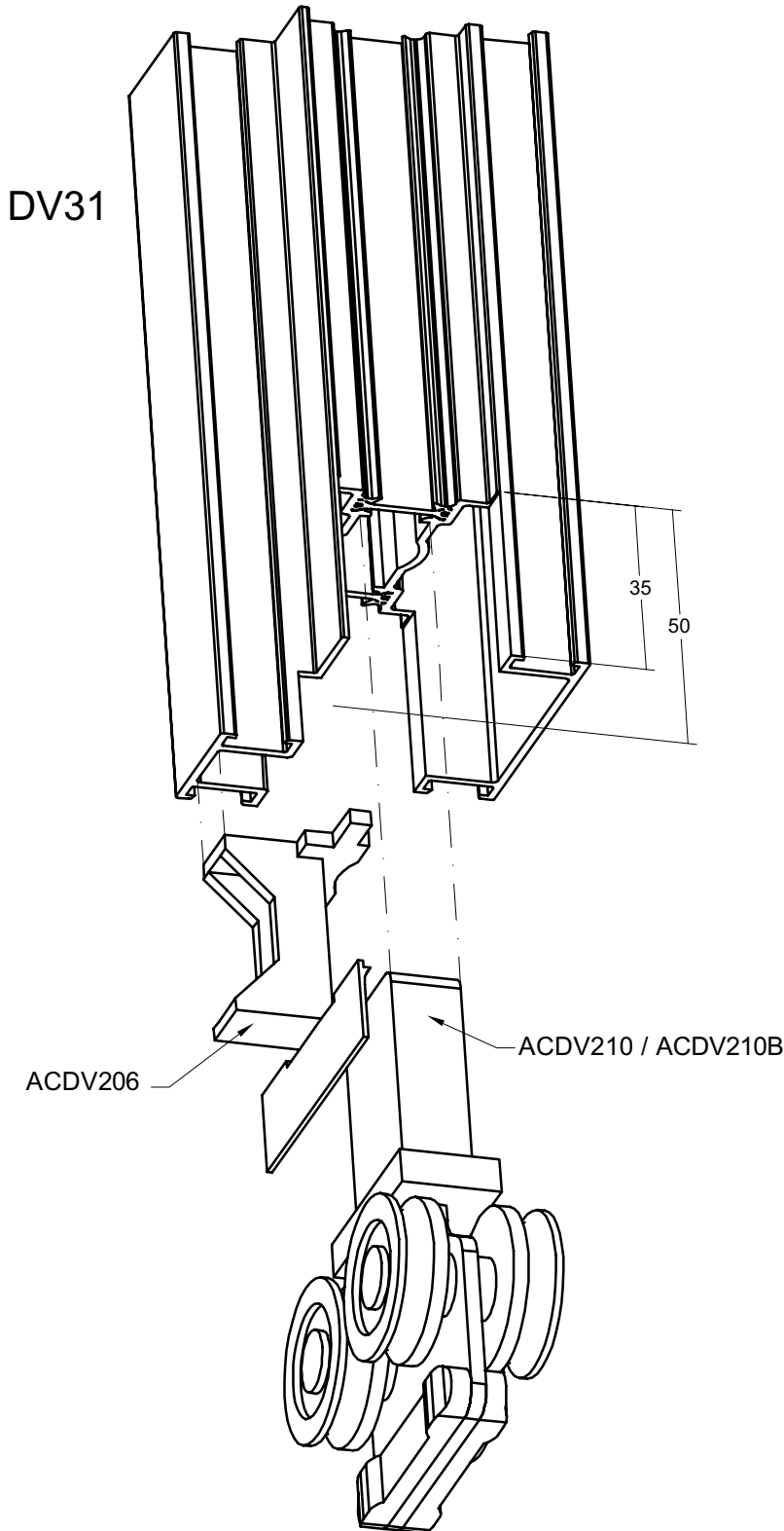

werkt05

MONTAGE ACDV210 EN ACDV219 IN DV31 VOOR DV70
MONTAGE ACDV210 ET ACDV219 DANS DV31 POUR DV70
MONTAGE ACDV210 UND ACDV219 IN DV31 FÜR DV70
MONTAGE ACDV210 AND ACDV219 IN DV31 FOR DV70

WERKTEKENINGEN - DESSINS DE CONSTRUCTION - KONSTRUKTIONZEICHNUNGEN - CONSTRUCTION DRAWING

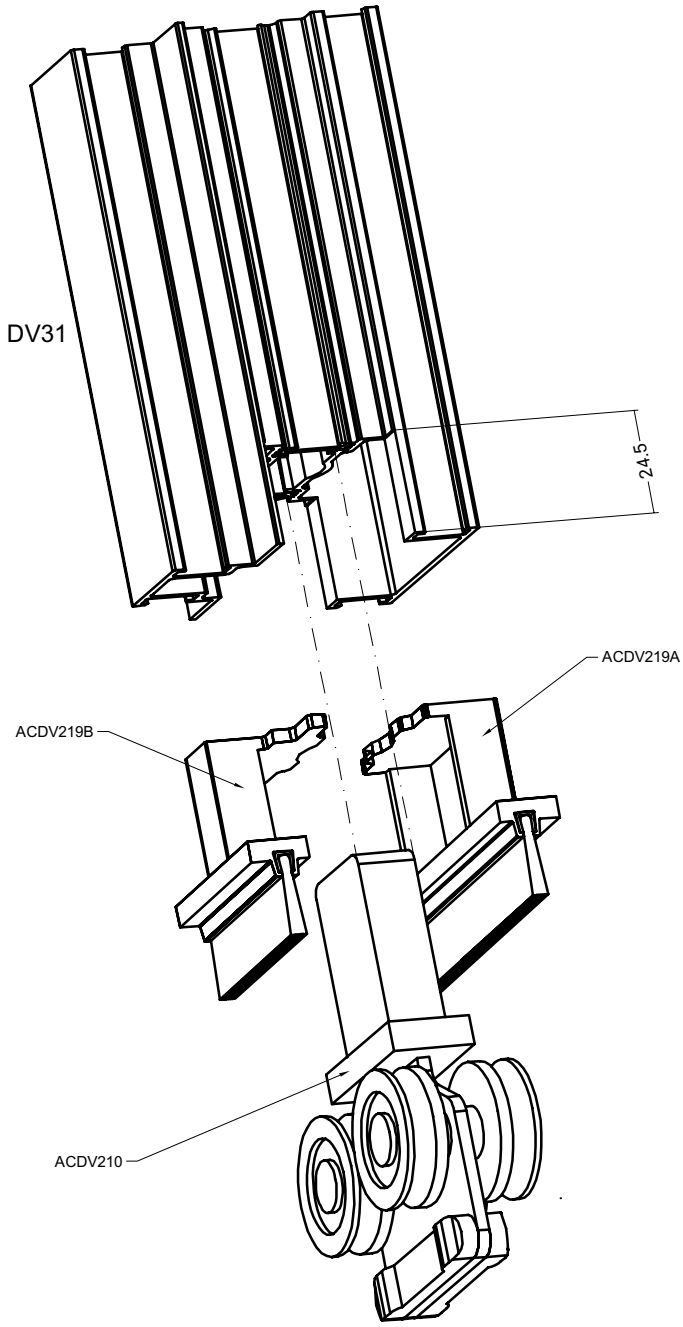

Werk06

MONTAGE ACDV206 EN ACDV213 IN DV31
MONTAGE ACDV206 ET ACDV213 DANS DV31
MONTAGE ACDV206 UND ACDV213 IN DV31
MONTAGE ACDV206 AND ACDV213 IN DV31

WERKTEKENINGEN - DESSINS DE CONSTRUCTION - KONSTRUKTIONZEICHNUNGEN - CONSTRUCTION DRAWING

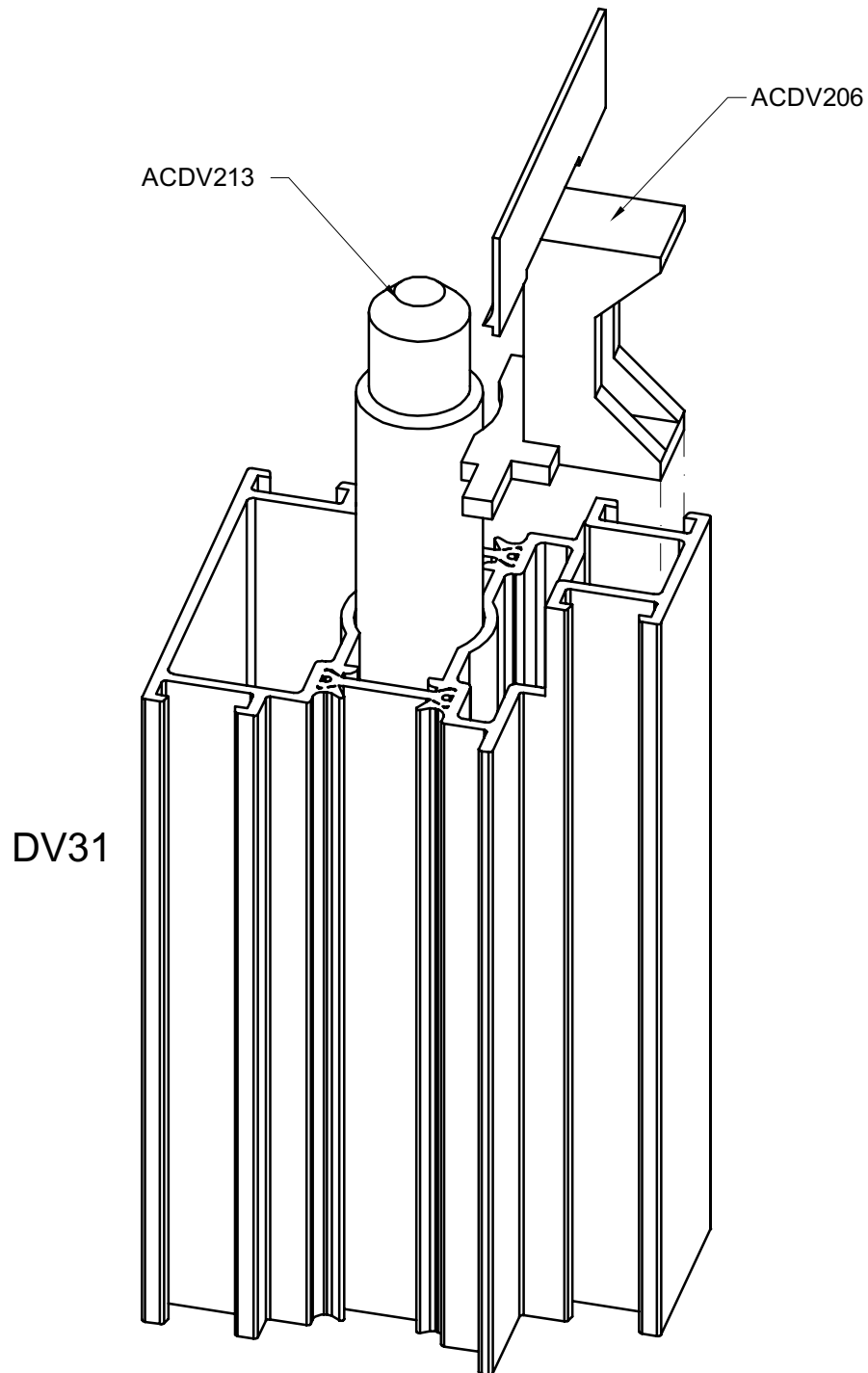

MONTAGE ACDV206 EN ACDV213 IN DV31 VOOR DV10
MONTAGE ACDV206 ET ACDV213 DANS DV31 POUR DV10
MONTAGE ACDV206 UND ACDV213 IN DV31 FÜR DV10
MONTAGE ACDV206 AND ACDV213 IN DV31 FOR DV10

WERKTEKENINGEN - DESSINS DE CONSTRUCTION - KONSTRUKTIONZEICHNUNGEN - CONSTRUCTION DRAWING

DV31

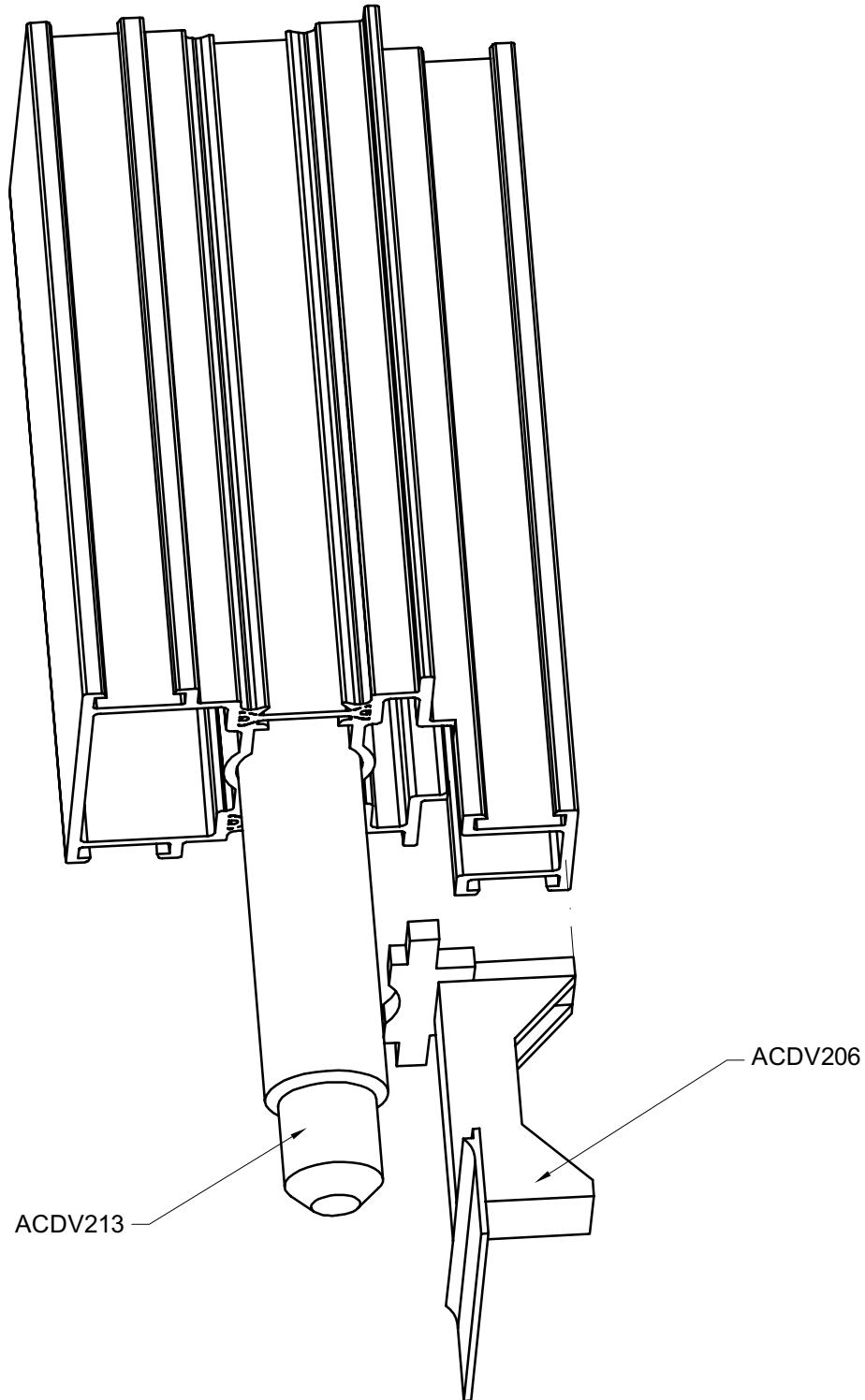

werkt08

MONTAGE ACDV219 EN ACDV213 IN DV31 VOOR DV70
MONTAGE ACDV219 ET ACDV213 DANS DV31 POUR DV70
MONTAGE ACDV219 UND ACDV213 IN DV31 FÜR DV70
MONTAGE ACDV219 AND ACDV213 IN DV31 FOR DV70

WERKTEKENINGEN - DESSINS DE CONSTRUCTION - KONSTRUKTIONZEICHNUNGEN - CONSTRUCTION DRAWING

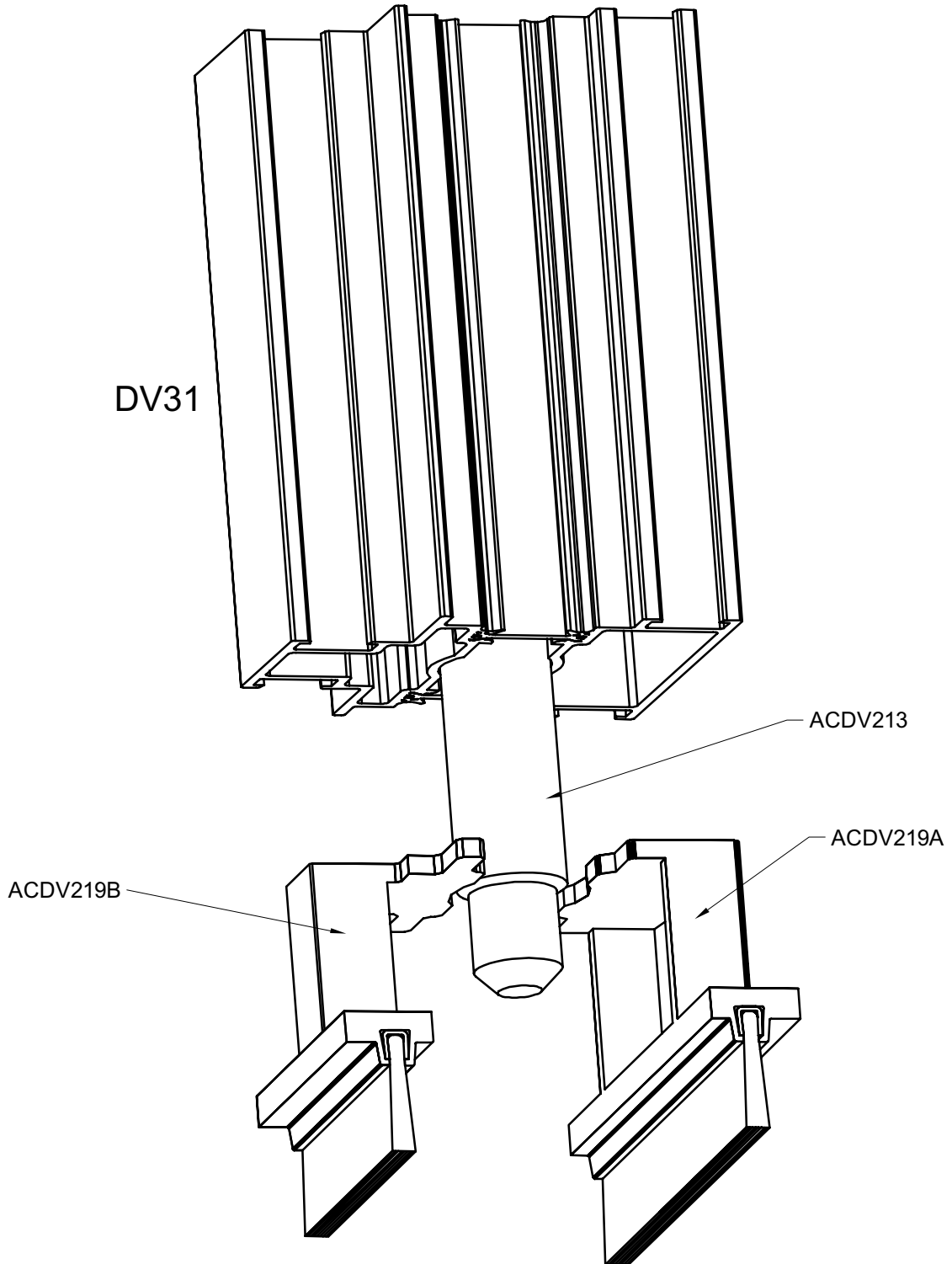

UITSPARING IN DV31 VOOR DV10 - LOOPWAGEN ACDV210 / GLIJBLOK ACDV209
 ENTAILLES DANS DV31 POUR DV10 - ROULETTE ACDV210 / BLOCK DE GUIDAGE ACDV209
 AUSSPARUNGEN IN DV31 FÜR DV10 - LAUFWERK ACDV210 / FUHRUNGSSTÜCK ACDV209
 MACHINING IN DV31 FOR DV10 - ROLLING BLOCK ACDV210 / SLIDING BLOCK ACDV209

WERKTEKENINGEN - DESSINS DE CONSTRUCTION - KONSTRUKTIONZEICHNUNGEN - CONSTRUCTION DRAWING

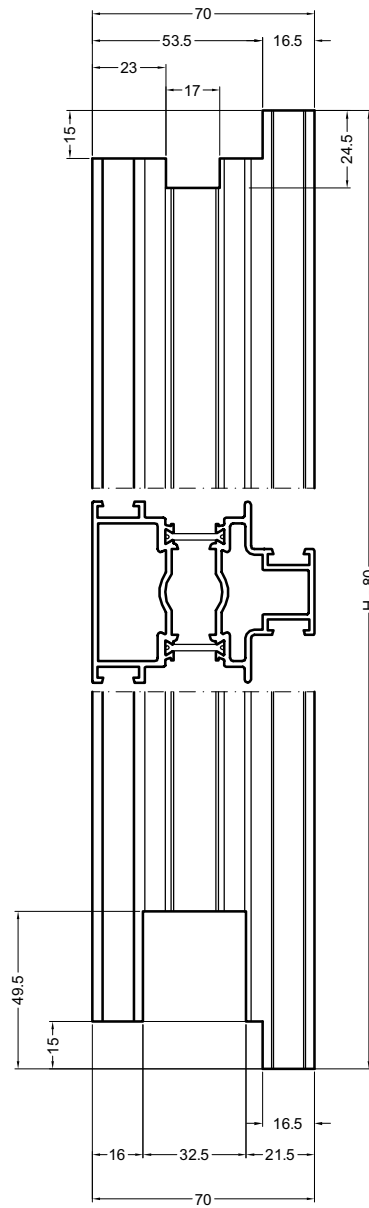
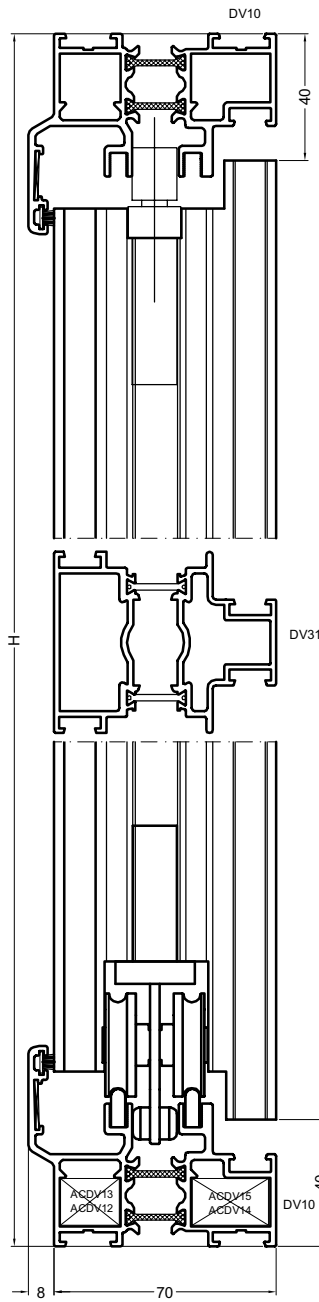
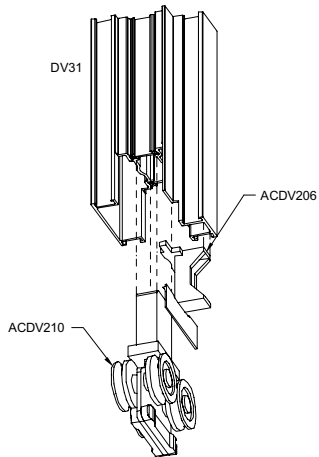
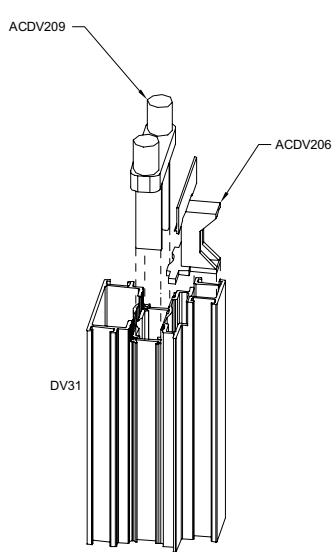
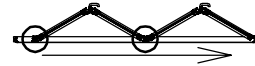
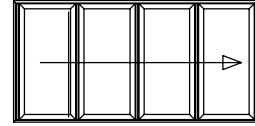

WERKT10

UITSPARING IN DV31 VOOR DV10
ENTAILLES DANS DV31 POUR DV10
AUSSPARUNGEN IN DV31 FÜR DV10
MACHINING IN DV31 FOR DV10

WERKTEKENINGEN - DESSINS DE CONSTRUCTION - KONSTRUKTIONZEICHNUNGEN - CONSTRUCTION DRAWING

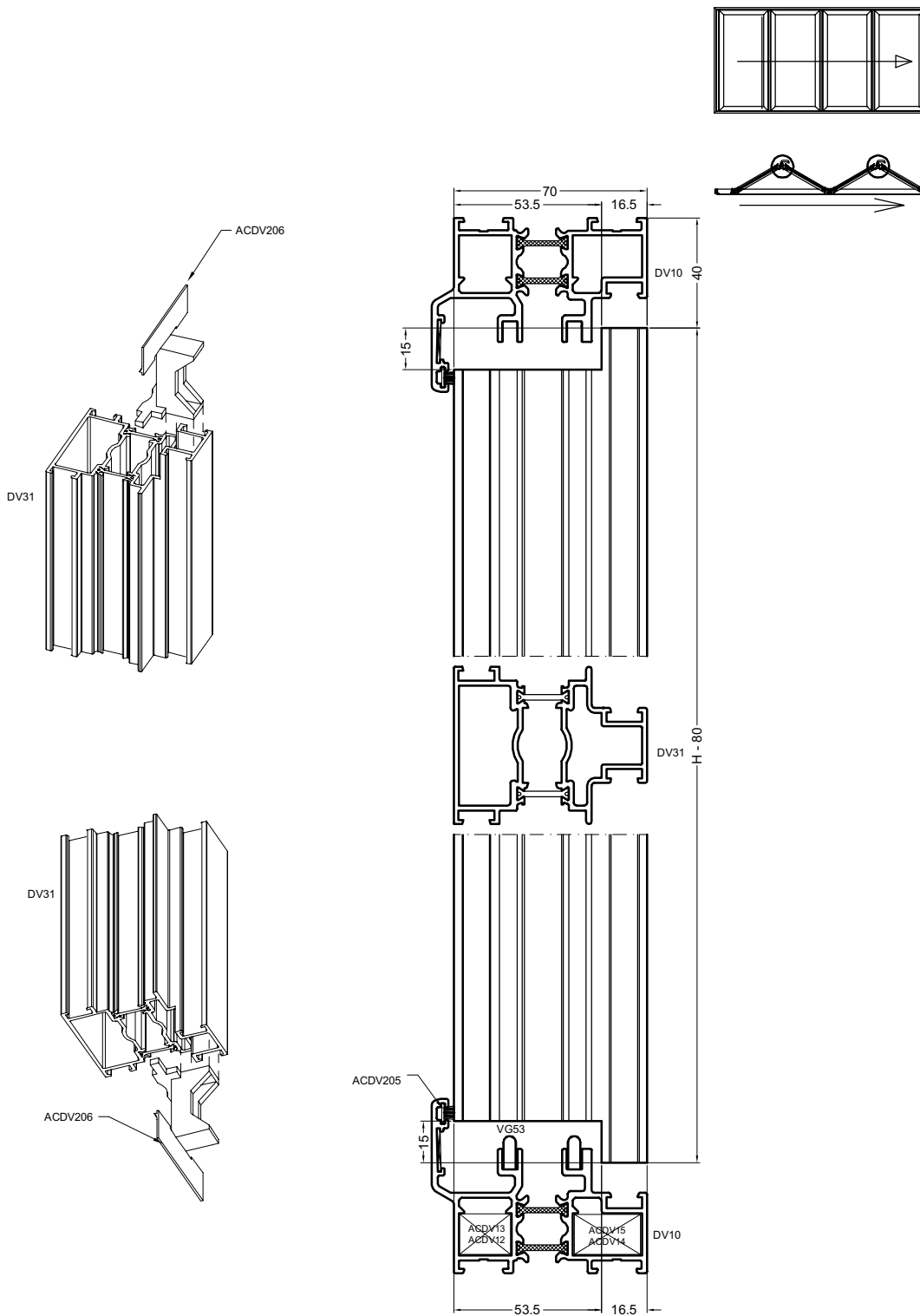

werk11

UITSPARING IN DV31 VOOR DV70 - LOOPWAGEN ACDV210 / GLIJBLOK ACDV209
ENTAILLES DANS DV31 POUR DV70 - ROULETTE ACDV210 / BLOCK DE GUIDAGE ACDV209
AUSSPARUNGEN IN DV31 FÜR DV70 - LAUFWERK ACDV210 / FUHRUNGSSTÜCK ACDV209
MACHINING IN DV31 FOR DV70 - ROLLING BLOCK ACDV210 / SLIDING BLOCK ACDV209

WERKTEKENINGEN - DESSINS DE CONSTRUCTION - KONSTRUKTIONZEICHNUNGEN - CONSTRUCTION DRAWING

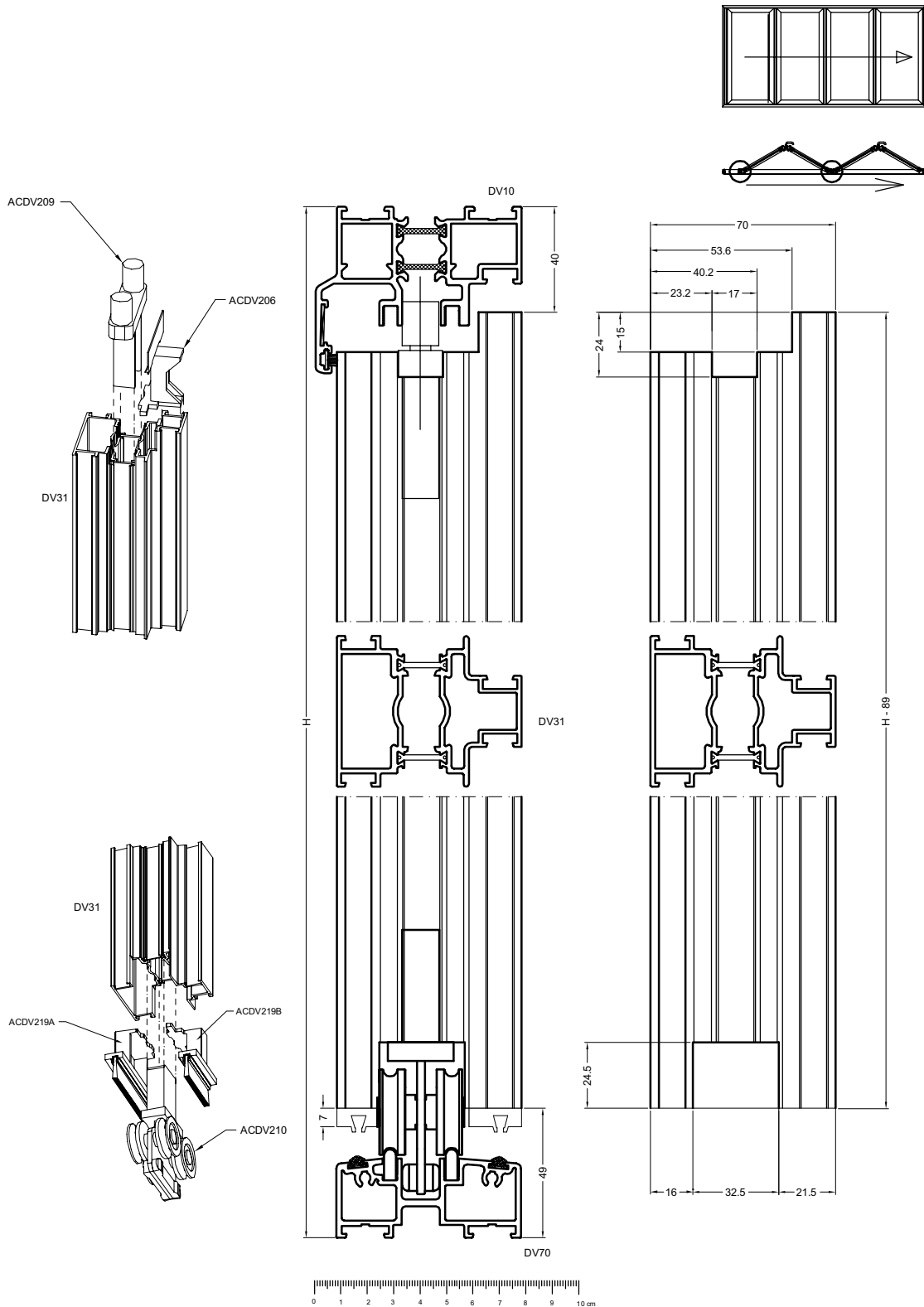

werk12

UITSPARING IN DV31 VOOR DV70
ENTAILLES DANS DV31 FUR DV70
AUSSPARUNGEN IN DV31 FUR DV70
MACHINING IN DV31 FOR DV70

WERKTEKENINGEN - DESSINS DE CONSTRUCTION - KONSTRUKTIONZEICHNUNGEN - CONSTRUCTION DRAWING

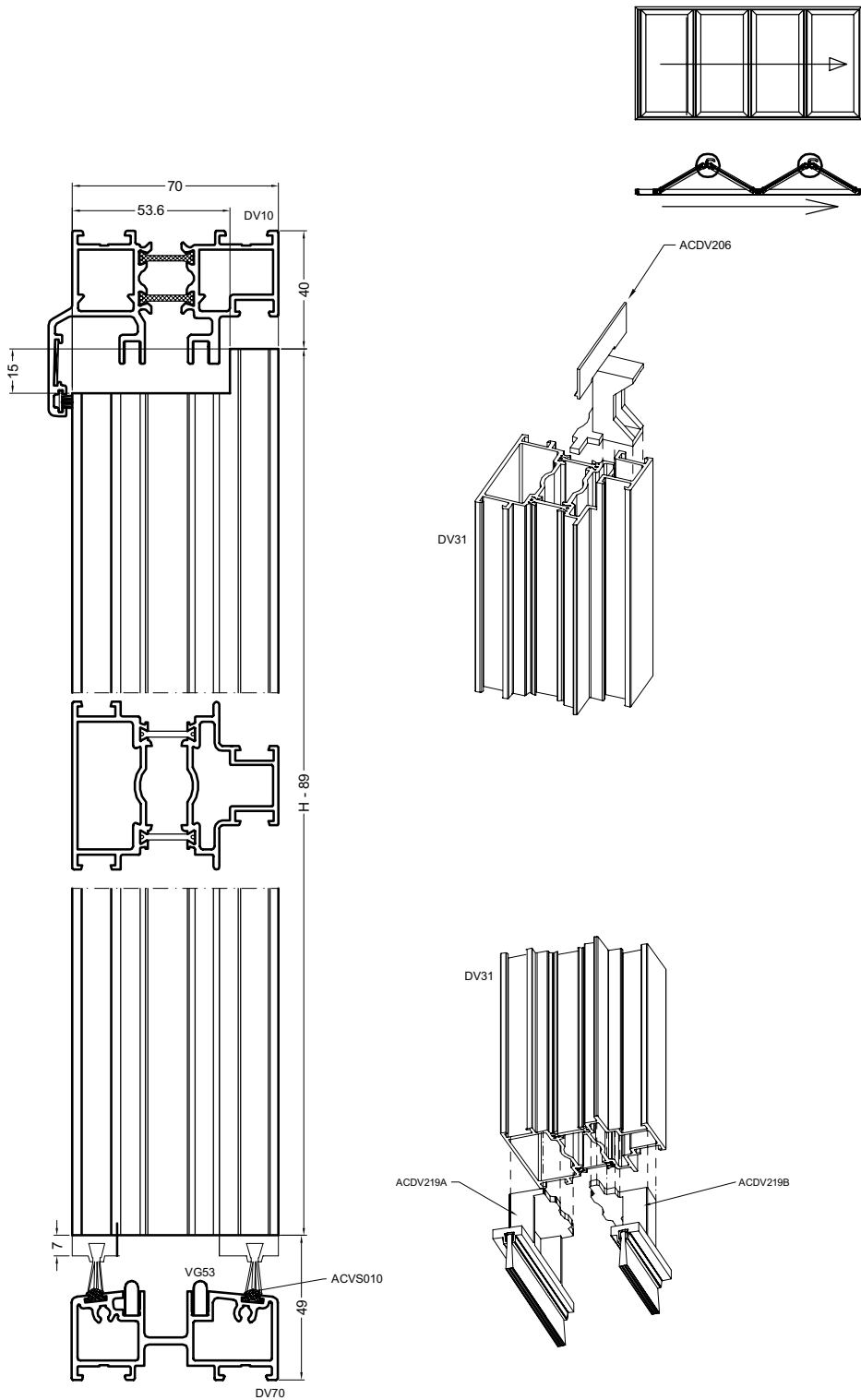

MONTAGE ACDV223 IN DV31
MONTAGE ACDV223 DANS DV31
MONTAGE ACDV223 IN DV31
MONTAGE ACDV223 IN DV31

WERKTEKENINGEN - DESSINS DE CONSTRUCTION - KONSTRUKTIONZEICHNUNGEN - CONSTRUCTION DRAWING

DETAIL ACDV224R

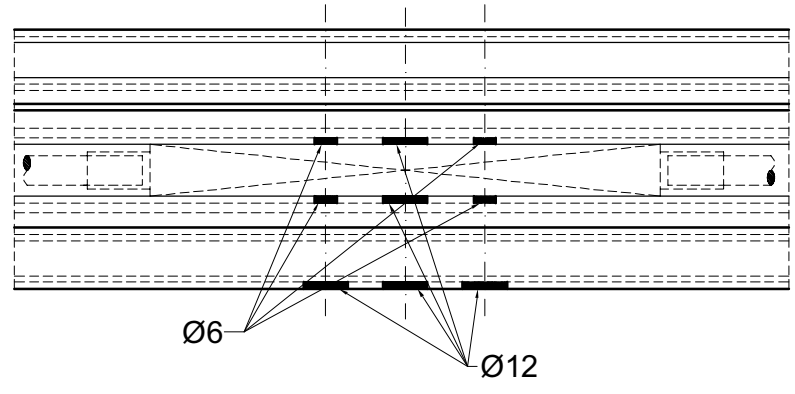
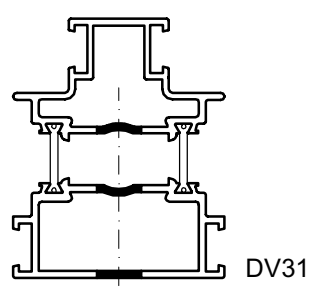
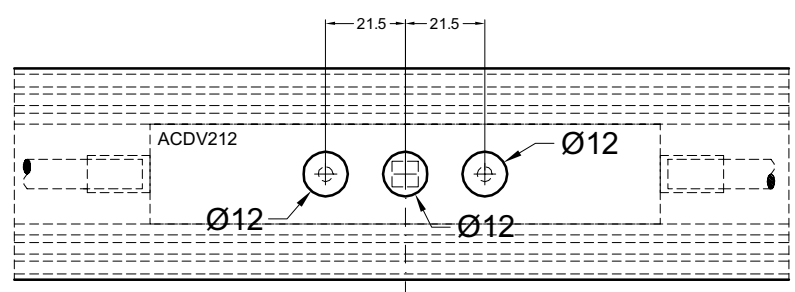
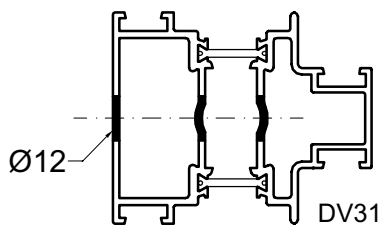
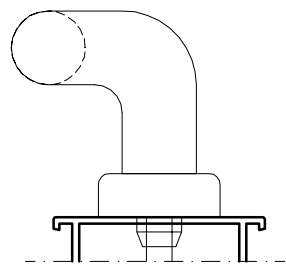
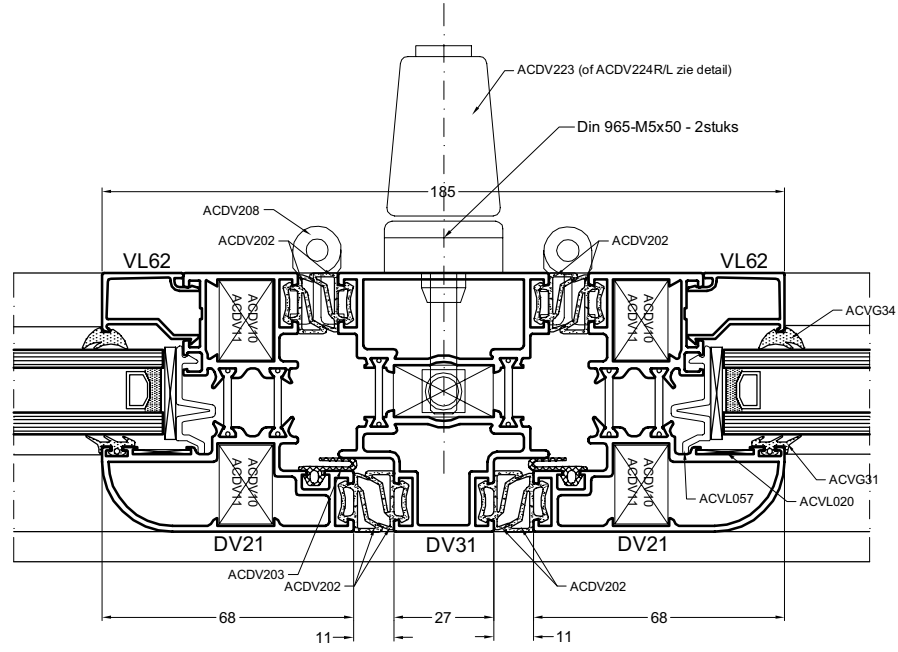

acdV223

MONTAGE GREDEL ACDV207
MONTAGE VERROU ACDV207
MONTAGE SCHIEBER ACDV207
MONTAGE BOLT ACDV207

WERKTEKENINGEN - DESSINS DE CONSTRUCTION - KONSTRUKTIONZEICHNUNGEN - CONSTRUCTION DRAWINGS

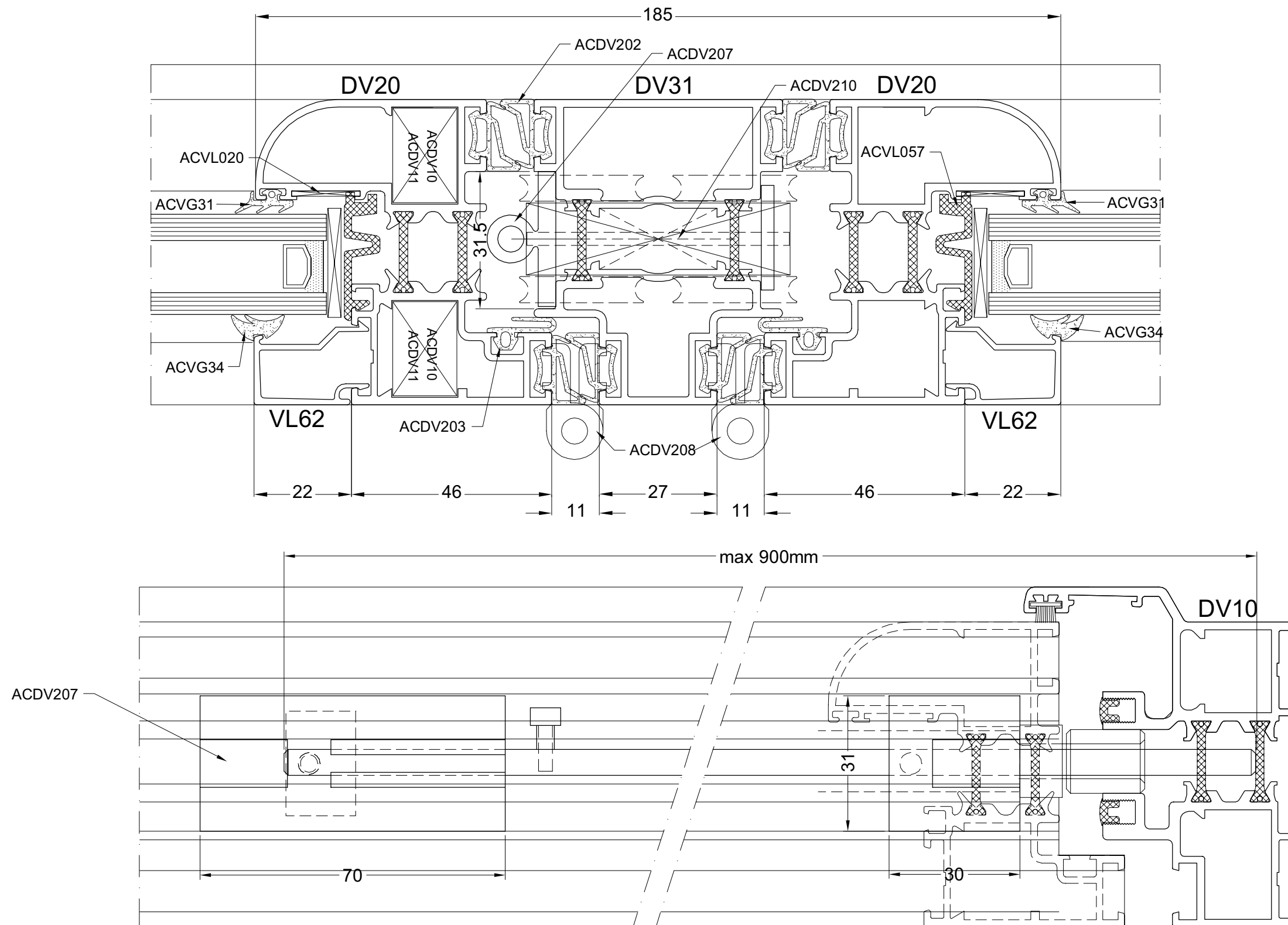

MONTAGE SLOT ACDV116, ACDV715, ACDV720 EN ACDV721 IN DV20
 MONTAGE SERRURE ACDV116, ACDV715, ACDV720 ET ACDV721 DANS DV20
 MONTAGE SCHLOSS ACDV116, ACDV715, ACDV720 UND ACDV721 IN DV20
 MONTAGE LOCK ACDV116, ACDV715, ACDV720 AND ACDV721 IN DV20

WERKTEKENINGEN - DESSINS DE CONSTRUCTION - KONSTRUKTIONZEICHNUNGEN - CONSTRUCTION DRAWINGS

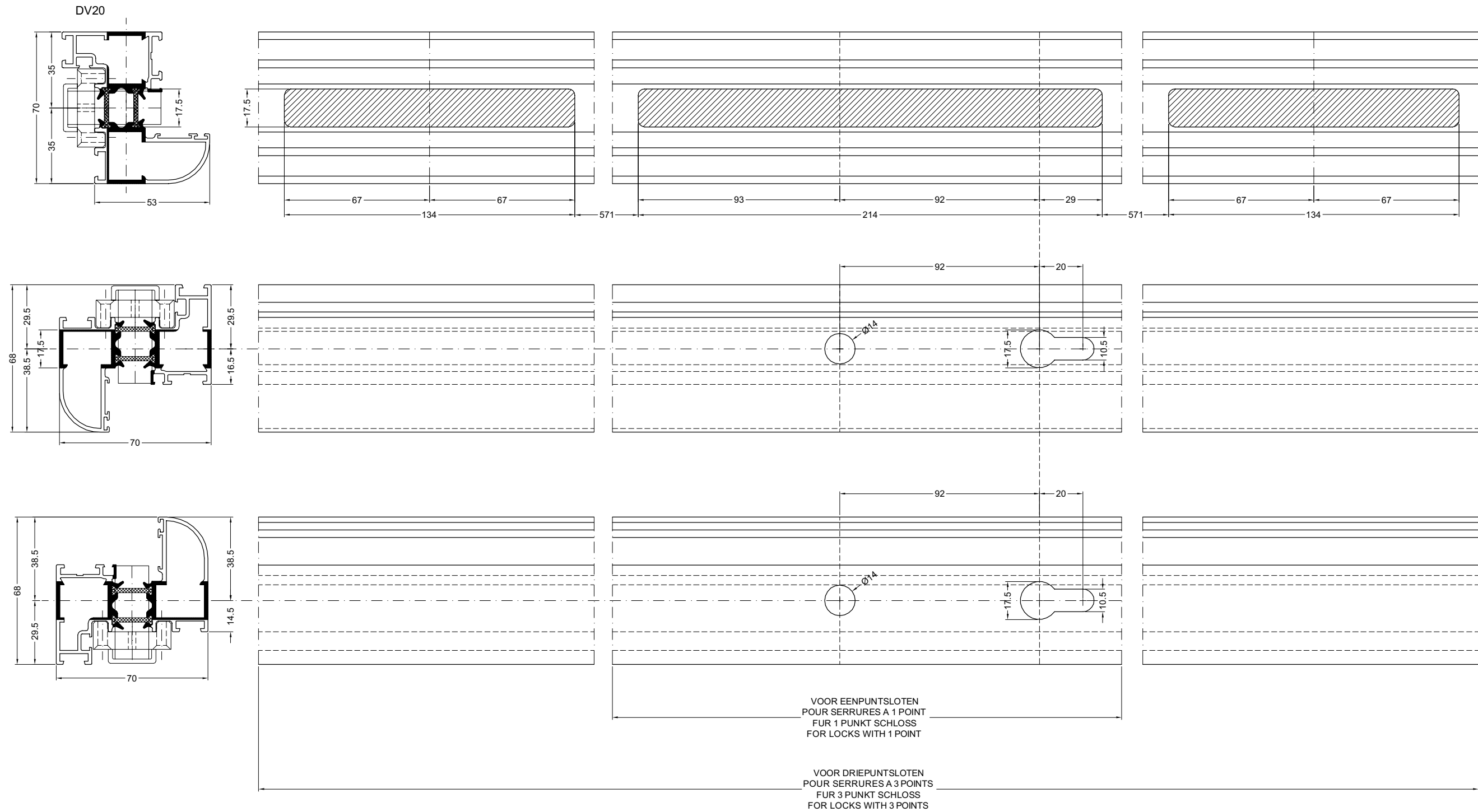

slot1

MONTAGE SLOT ACDV116, ACDV715, ACDV720 EN ACDV721 IN DV21
 MONTAGE SERRURE ACDV116, ACDV715, ACDV720 ET ACDV721 DANS DV21
 MONTAGE SCHLOSS ACDV116, ACDV715, ACDV720 UND ACDV721 IN DV21
 MONTAGE LOCK ACDV116, ACDV715, ACDV720 AND ACDV721 IN DV21

WERKTEKENINGEN - DESSINS DE CONSTRUCTION - KONSTRUKTIONZEICHNUNGEN - CONSTRUCTION DRAWINGS

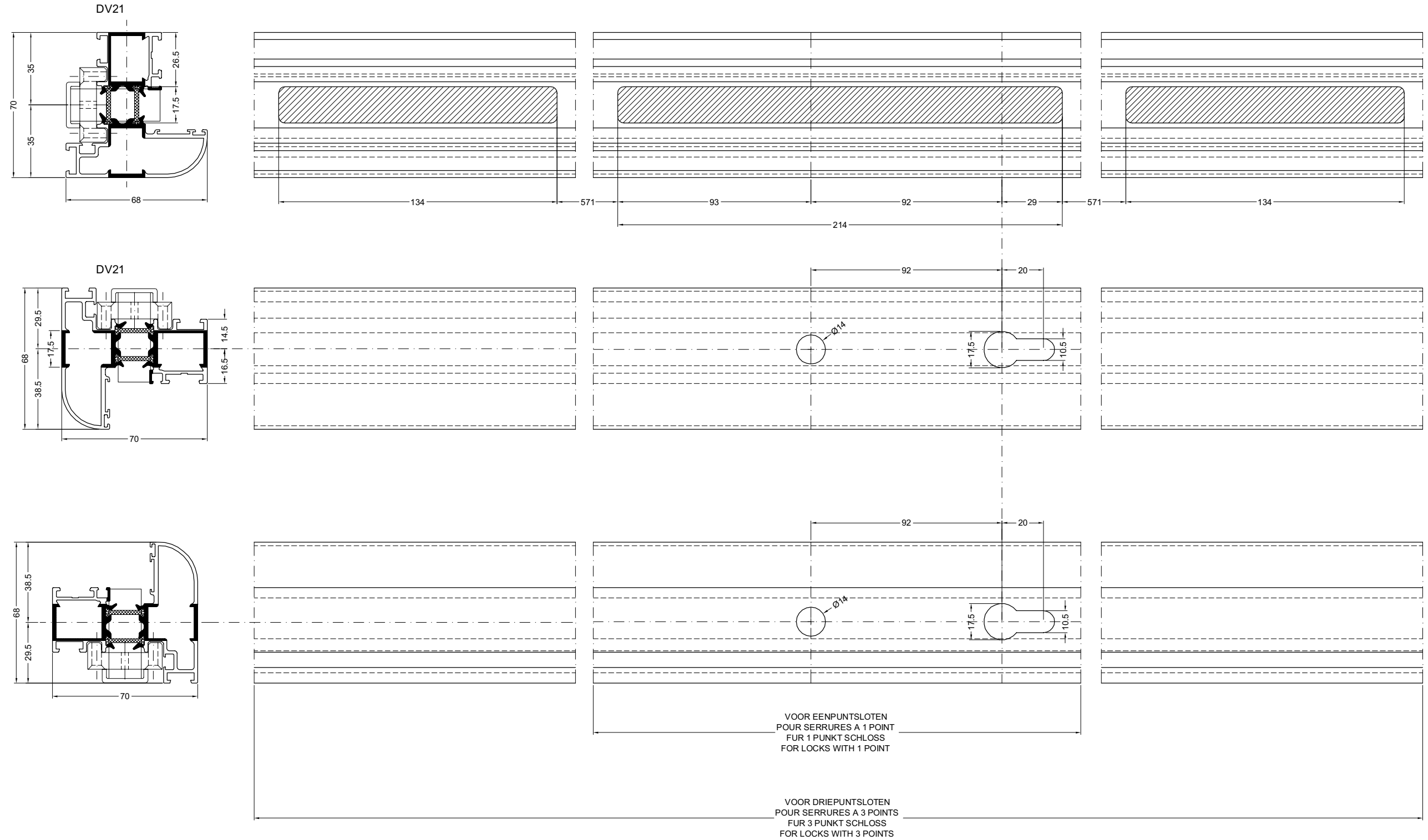

slot2

MONTAGE SLOTPLATEN IN DV10 EN DV31
MONTAGE GACHES DANS DV10 ET DV31
MONTAGE SCHLISS PLATE IN DV10 UND DV31
MONTAGE LOCK PLATES IN DV10 AND DV31

WERKTEKENINGEN - DESSINS DE CONSTRUCTION - KONSTRUKTIONZEICHNUNGEN - CONSTRUCTION DRAWINGS

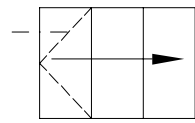

DV10

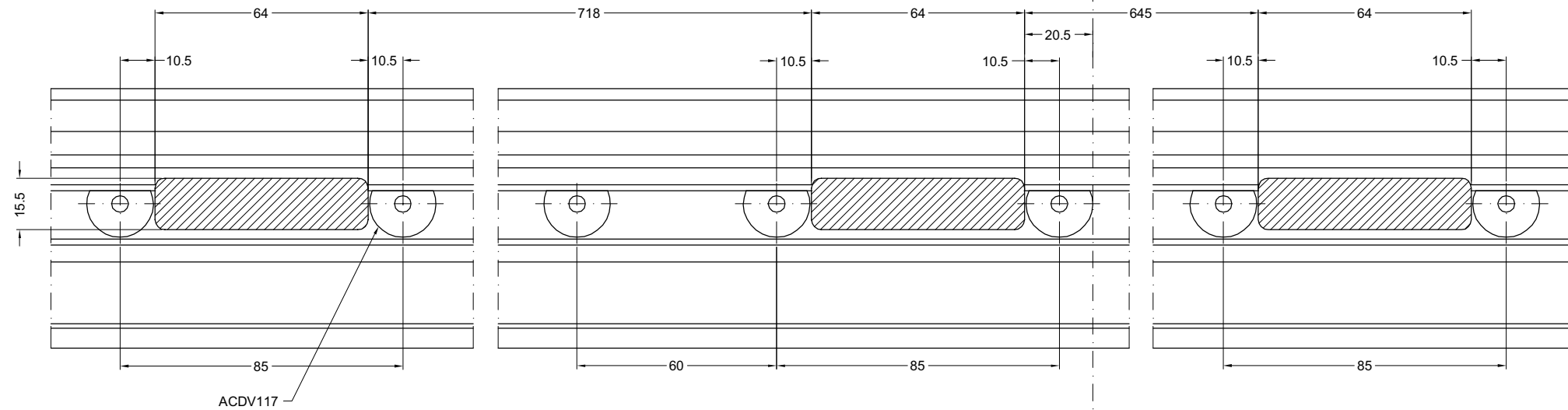
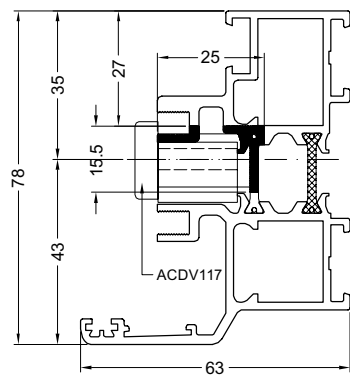

CILINDERHOOGTE
HAUTEUR DE LA CYLINDRE

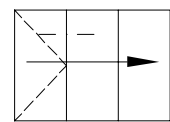
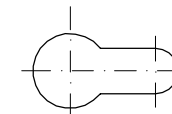

DV31

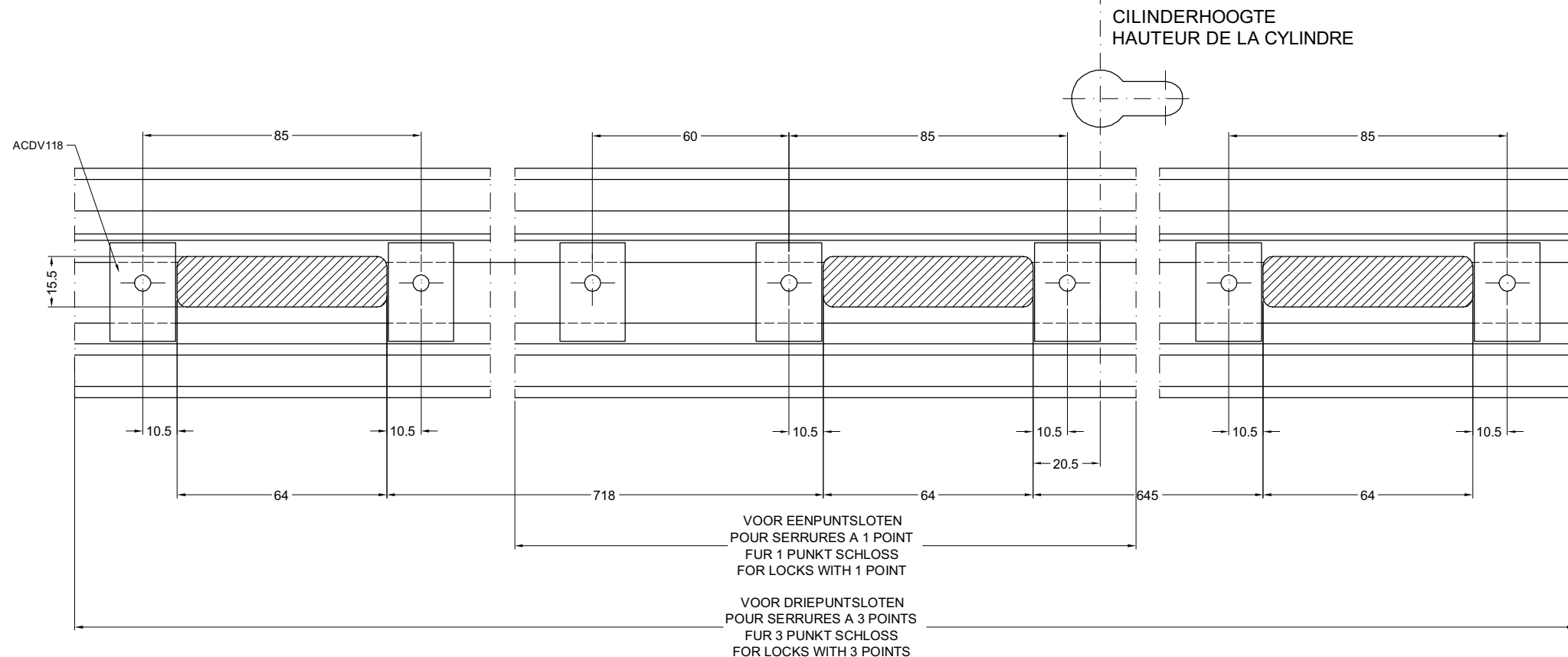
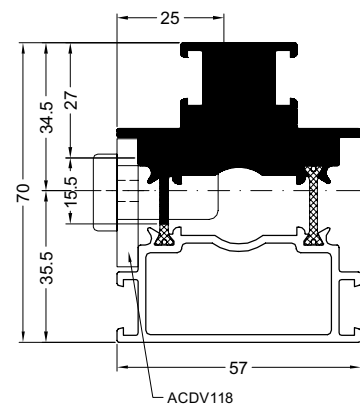

CILINDERHOOGTE
HAUTEUR DE LA CYLINDRE

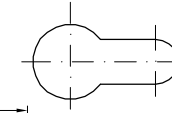

VOOR EENPUNTSLOTEN
POUR SERRURES A 1 POINT
FUR 1 PUNKT SCHLOSS
FOR LOCKS WITH 1 POINT

VOOR DRIEPUNTSLOTEN
POUR SERRURES A 3 POINTS
FUR 3 PUNKT SCHLOSS
FOR LOCKS WITH 3 POINTS



MONTAGE STANGENSLOT IN DV31 MET DV10 EN DV70 BUITENDRAAIEND
 MONTAGE SERRURE A TRINGLE DANS DV31 AVEC DV10 ET DV70 OUVRANT EXTERIEUR
 MONTAGE STANGE SCHLOSS IN DV31 MIT DV10 UND DV70 AUSSEN DREHEND
 MONTAGE BOLT LOCK IN DV31 WITH DV10 AND DV70 OUTWARDS OPENING

WERKTEKENINGEN - DESSINS DE CONSTRUCTION - KONSTRUKTIONZEICHNUNGEN - CONSTRUCTION DRAWINGS

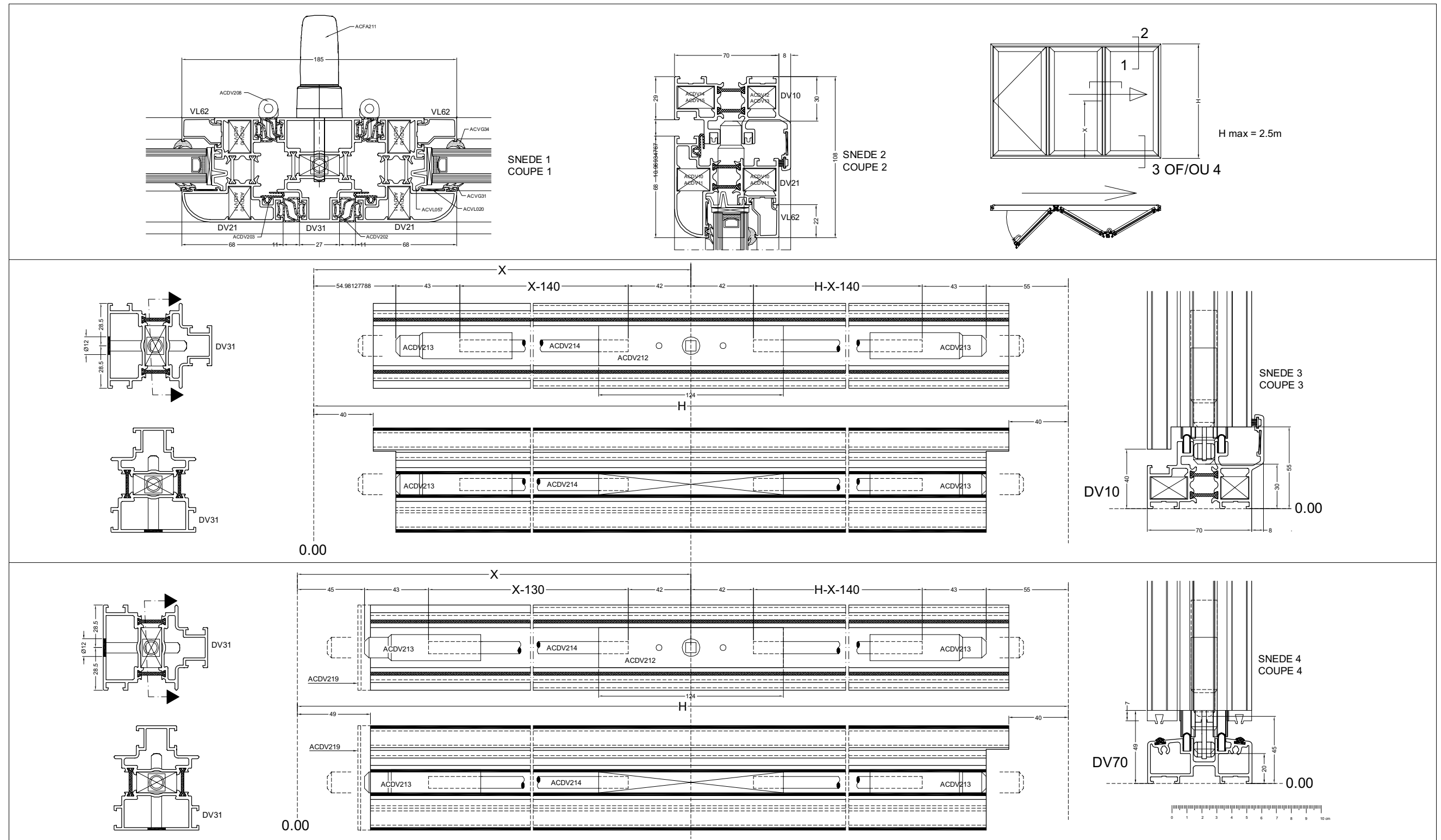

MONTAGE STANGENSLOT IN DV31 MET DV10 EN DV70 BINNENDRAAIEND
 MONTAGE SERRURE A TRINGLE DANS DV31 AVEC DV10 ET DV70 OUVRANT INTERIEUR
 MONTAGE STANGE SCHLOSS IN DV31 MIT DV10 UND DV70 INNEN DREHEND
 MONTAGE BOLT LOCK IN DV31 WITH DV10 AND DV70 INWARDS OPENING

WERKTEKENINGEN - DESSINS DE CONSTRUCTION - KONSTRUKTIONZEICHNUNGEN - CONSTRUCTION DRAWINGS

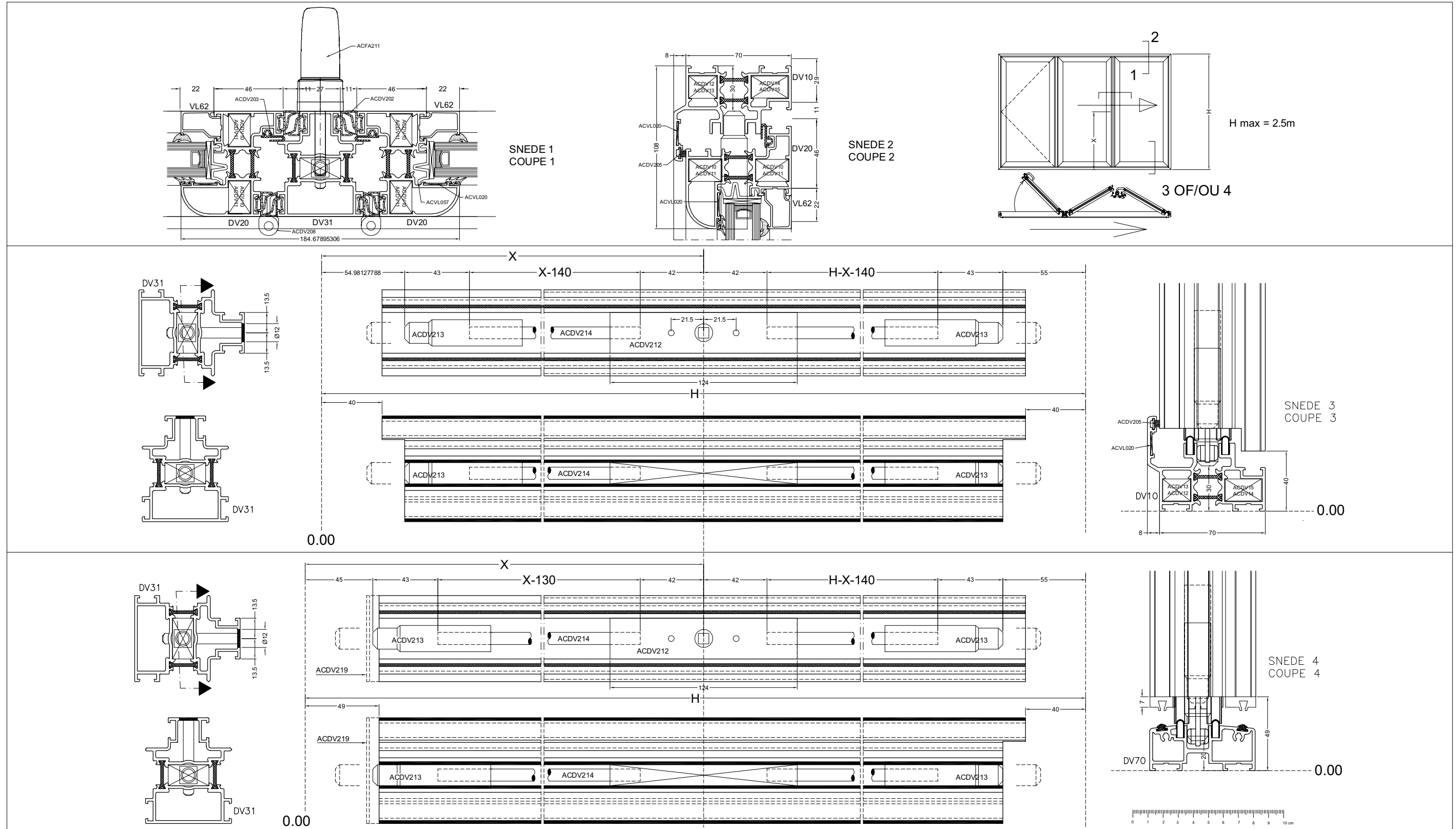

MONTAGE STANGENSLOT IN DV20 MET DV10
MONTAGE SERRURE A TRINGLE DANS DV20 AVEC DV10
MONTAGE STANGE SCHLOSS IN DV20 MIT DV10
MONTAGE BOLT LOCK IN DV20 WITH DV10

WERKTEKENINGEN - DESSINS DE CONSTRUCTION - KONSTRUKTIONZEICHNUNGEN - CONSTRUCTION DRAWINGS

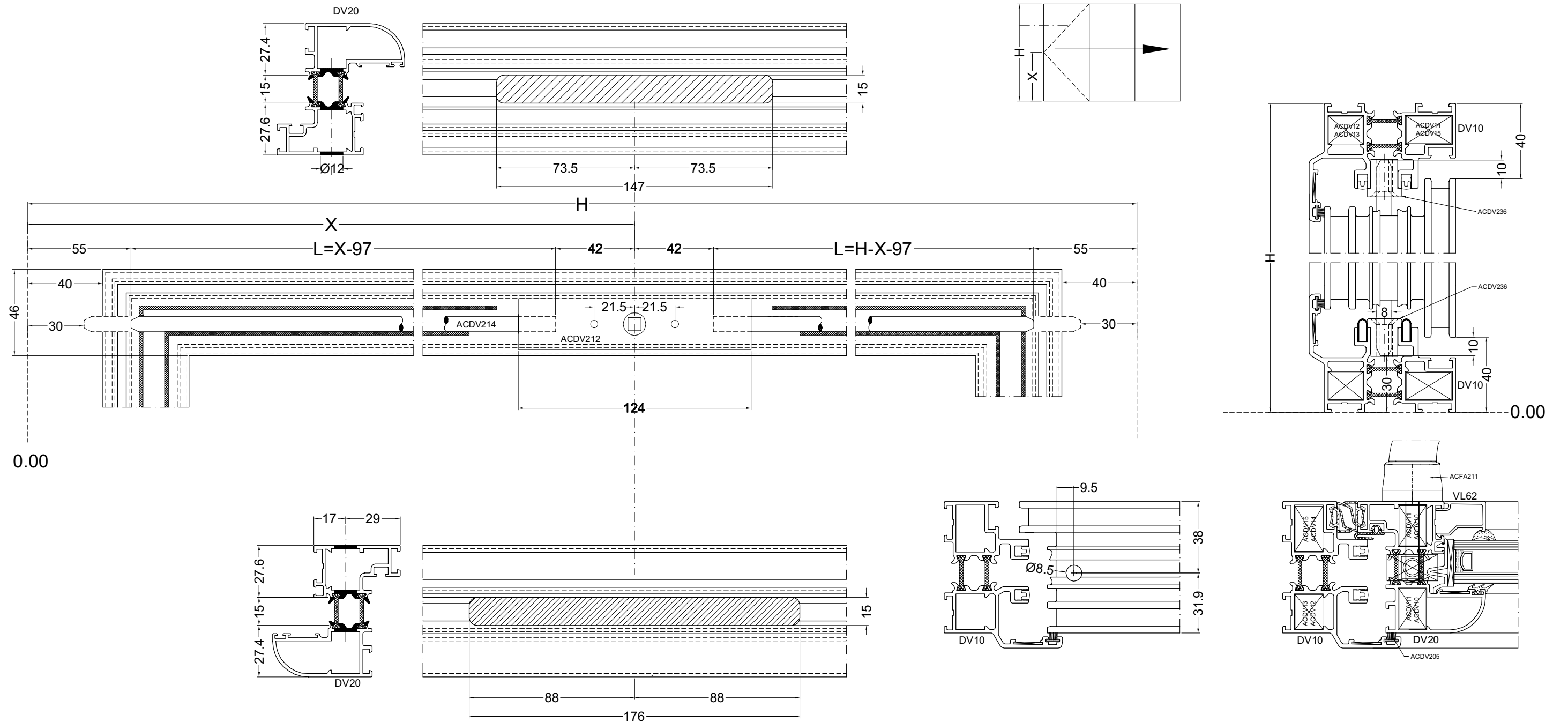

MONTAGE STANGENSLOT ACDV326 IN DV31
MONTAGE SERRURE A TRINGLE ACDV326 DANS DV31
MONTAGE STANGE SCHLOSS ACDV326 IN DV31
MONTAGE LOCK ACDV326 IN DV31

WERKTEKENINGEN - DESSINS DE CONSTRUCTION - KONSTRUKTIONZEICHNUNGEN - CONSTRUCTION DRAWINGS

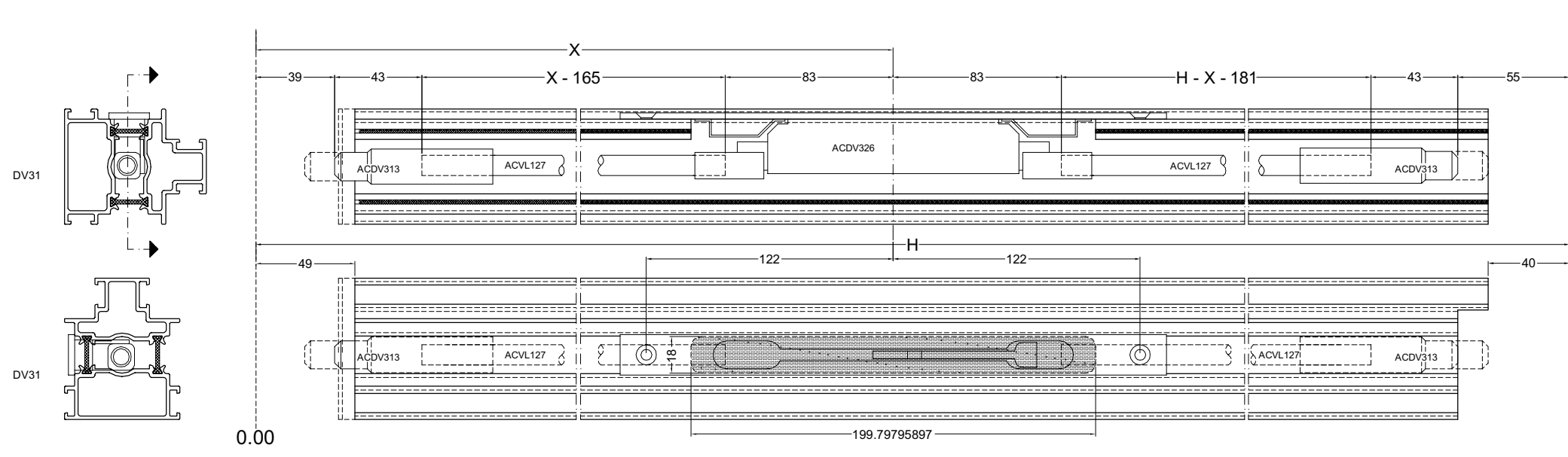
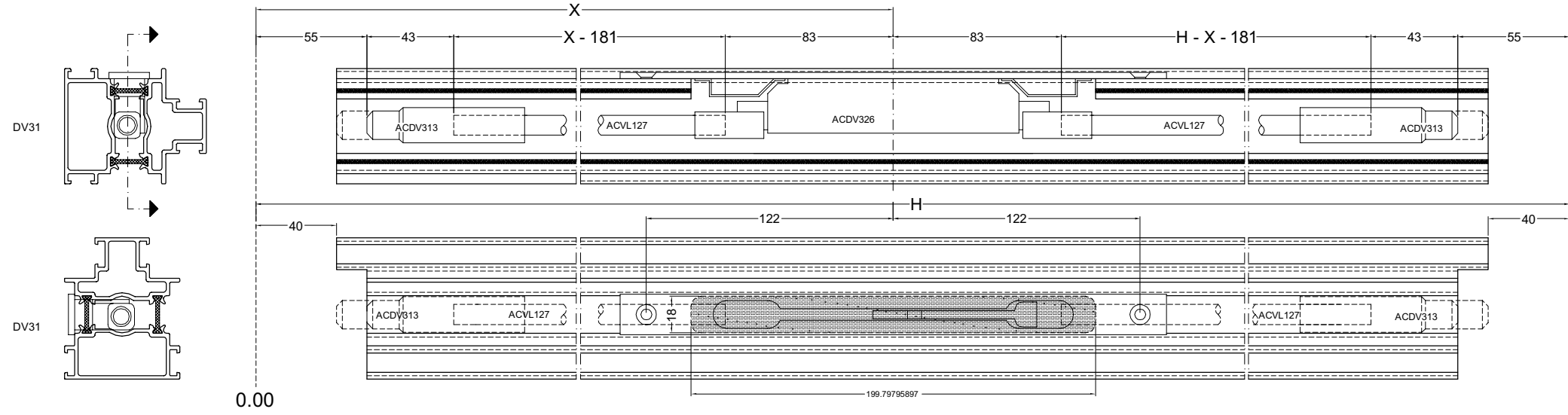
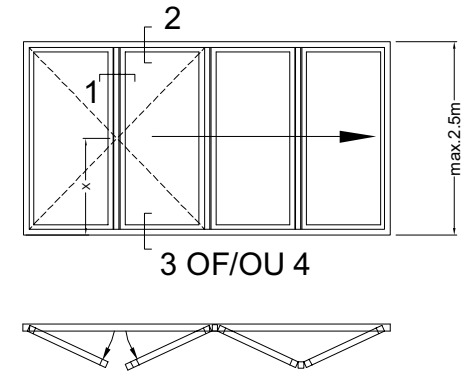
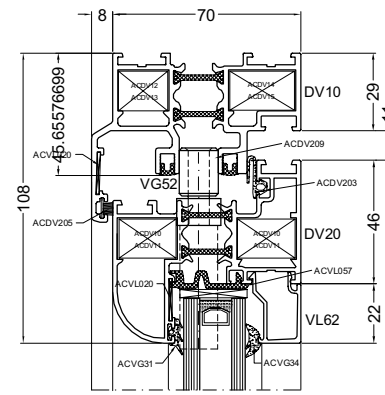
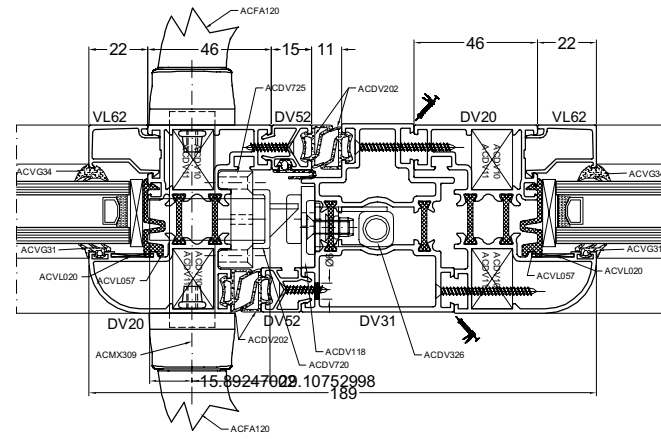

MONTAGE DV56
MONTAGE DV56
MONTAGE DV56
MONTAGE DV56

WERKTEKENINGEN - DESSINS DE CONSTRUCTION - KONSTRUKTIONZEICHNUNGEN - CONSTRUCTION DRAWINGS

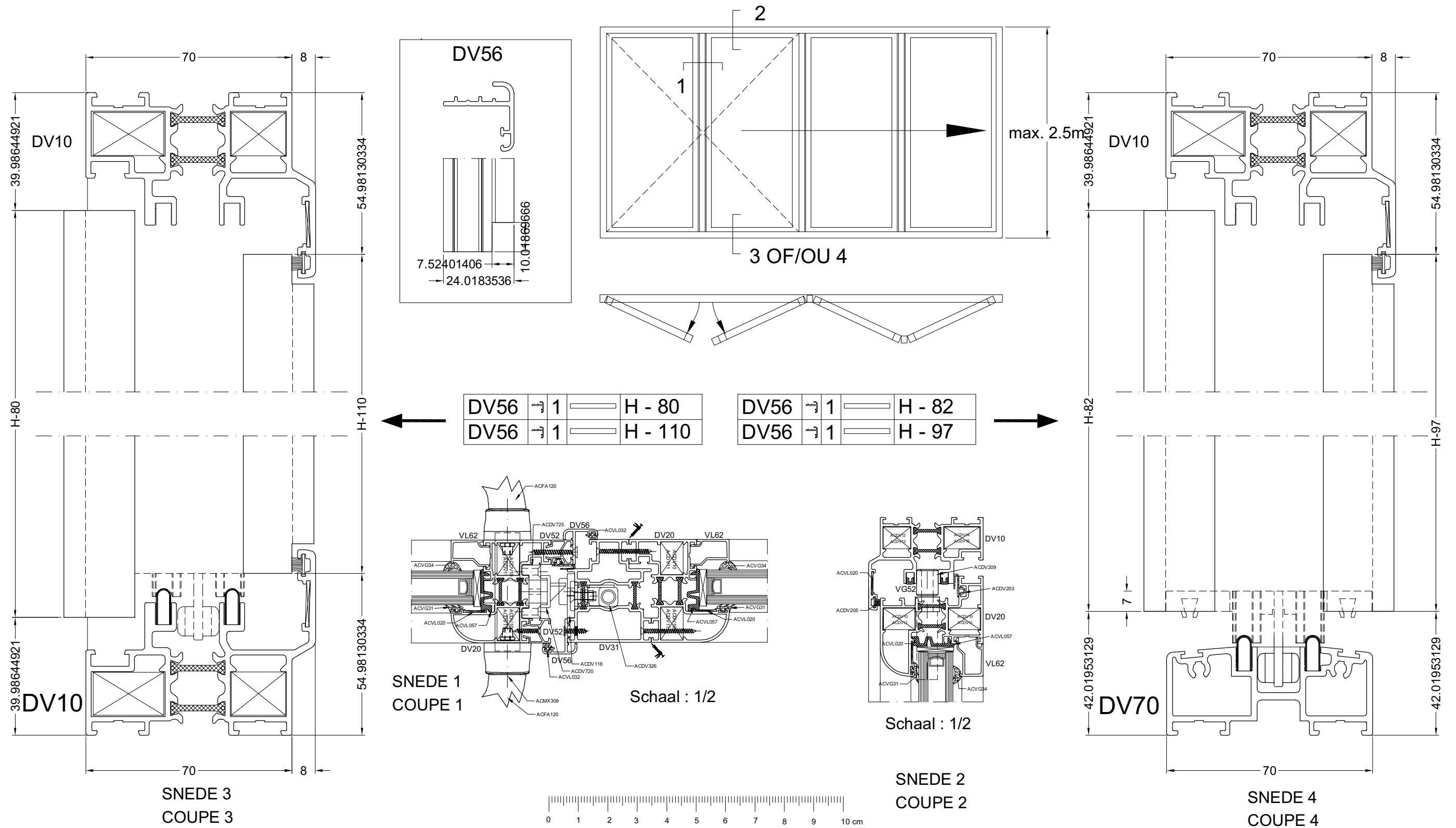

MONTAGE STANGENSLOT ACDV326 IN DV31
 MONTAGE SERRURE A TRINGLE ACDV326 DANS DV31
 MONTAGE STANGE SCHLOSS ACDV326 IN DV31
 MONTAGE BOLT LOCK ACDV326 IN DV31

WERKTEKENINGEN - DESSINS DE CONSTRUCTION - KONSTRUKTIONZEICHNUNGEN - CONSTRUCTION DRAWINGS

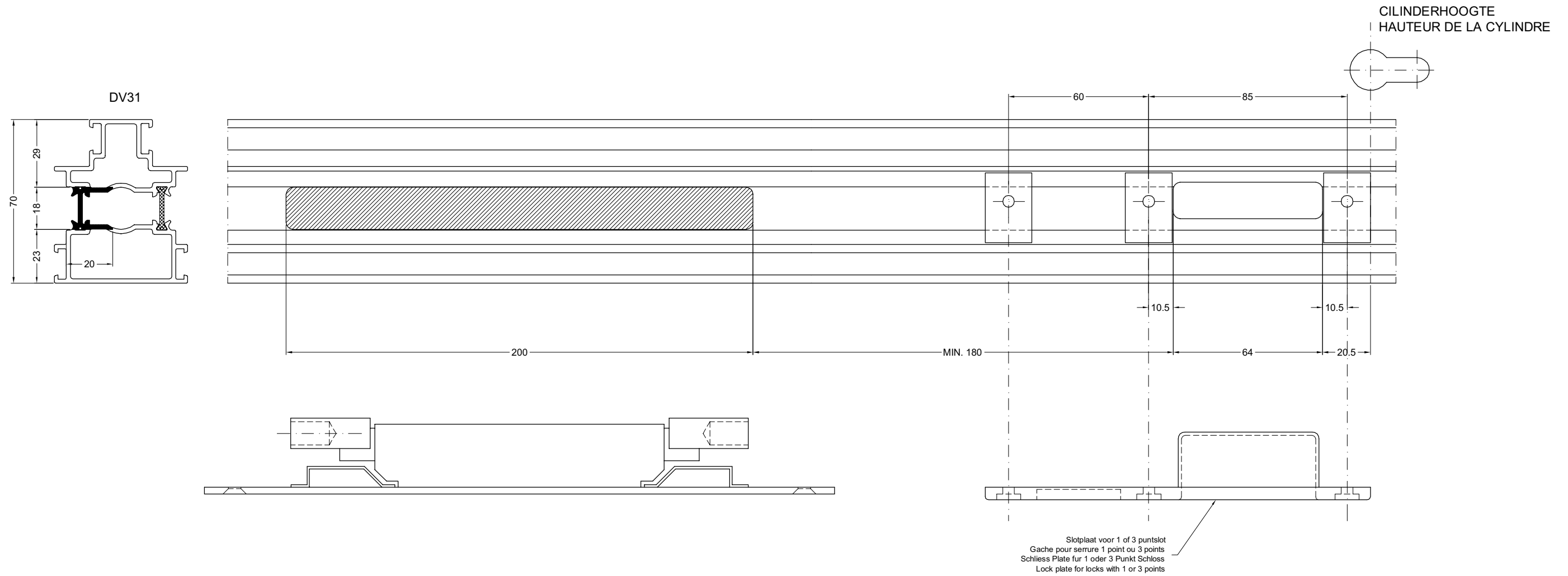

MONTAGE ACDV13 EN ACDV15, GEBRUIK BOORMAL MA31 VOOR DV10
MONTAGE ACDV13 ET ACDV15, USER GABARIT DE FORAGE MA31 POUR DV10
MONTAGE ACDV13 UND ACDV15, GEBRAUCH BOHRSCABLONE MA31 FUR DV10
MONTAGE ACDV13 AND ACDV15, USE DRILING JIG SET MA31 FOR DV10

WERKTEKENINGEN - DESSINS DE CONSTRUCTION - KONSTRUKTIONZEICHNUNGEN - CONSTRUCTION DRAWINGS

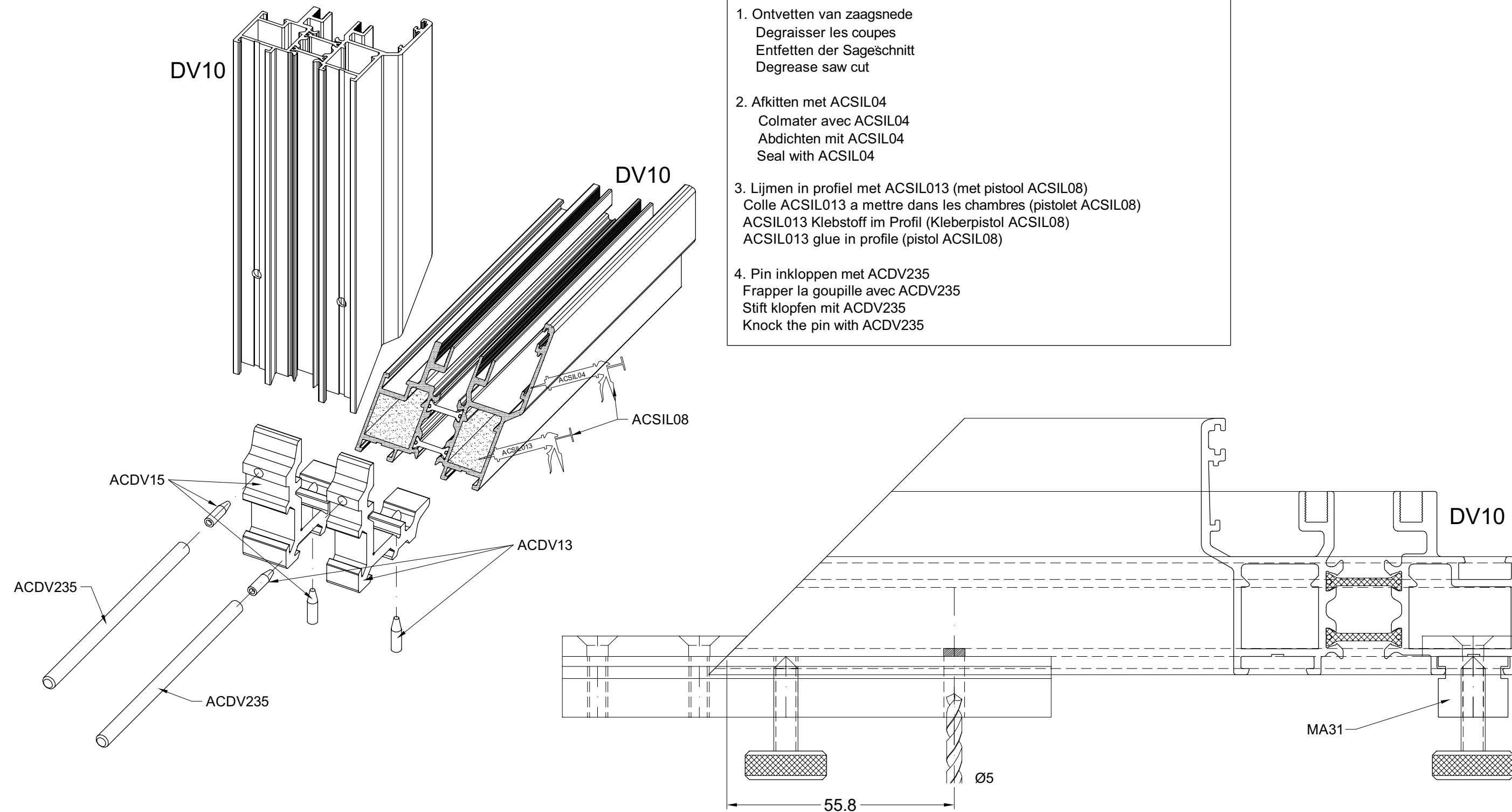

1. Ontvetten van zaagsnede
Degraisser les coupes
Entfetten der Sageßchnitt
Degrease saw cut
2. Afkitten met ACSIL04
Colmater avec ACSIL04
Abdichten mit ACSIL04
Seal with ACSIL04
3. Lijmen in profiel met ACSIL013 (met pistool ACSIL08)
Colle ACSIL013 a mettre dans les chambres (pistolet ACSIL08)
ACSIL013 Klebstoff im Profil (Kleberpistol ACSIL08)
ACSIL013 glue in profile (pistol ACSIL08)
4. Pin inkloppen met ACDV235
Frapper la goupille avec ACDV235
Stift klopfen mit ACDV235
Knock the pin with ACDV235

MONTAGE ACDV11, GEBRUIK BOORMAL MA32 VOOR DV20 EN DV21
 MONTAGE ACDV11, USER GABARIT DE FORAGE MA32 POUR DV20 ET DV21
 MONTAGE ACDV11, GEBRAUCH BOHRSCABLONE MA32 FUR DV20 UND DV21
 MONTAGE ACDV11, USE DRILING JIG SET MA32 FOR DV20 AND DV21

WERKTEKENINGEN - DESSINS DE CONSTRUCTION - KONSTRUKTIONZEICHNUNGEN - CONSTRUCTION DRAWINGS

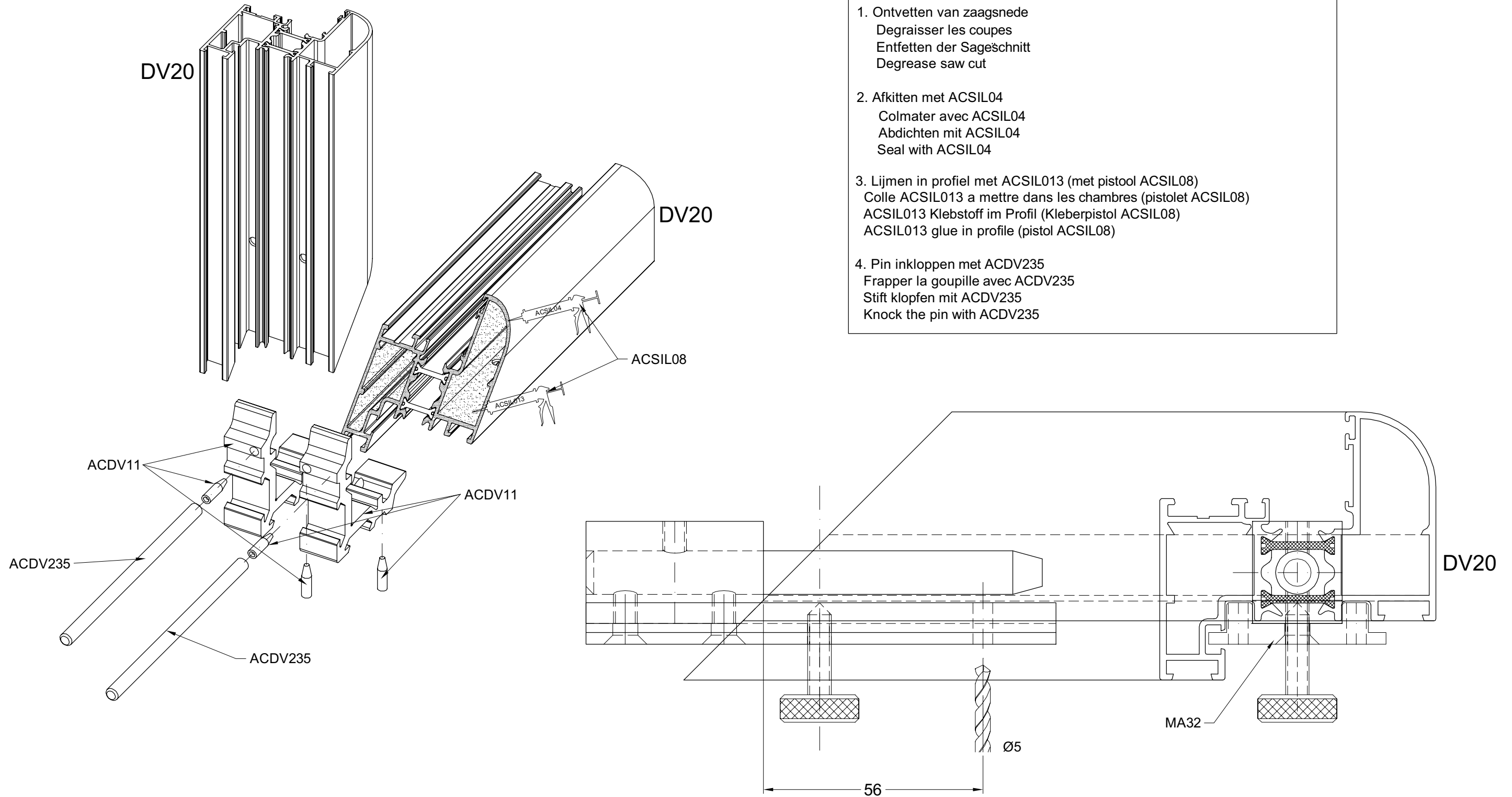

ONTWATERING - NAAR BINNEN OPENEND
EVACUATION D'EAU - OUVRANT INTERIEUR
ENTWASSERUNG - INNEN OFFNEND
WATER EVACUATION - PANELS INWARDS OPENING

WERKTEKENINGEN - DESSINS DE CONSTRUCTION - KONSTRUKTIONZEICHNUNGEN - CONSTRUCTION DRAWINGS

Ontwatering buitenkader
Drainage dormant
Entwässerung Rahmen
Drainage outer frame

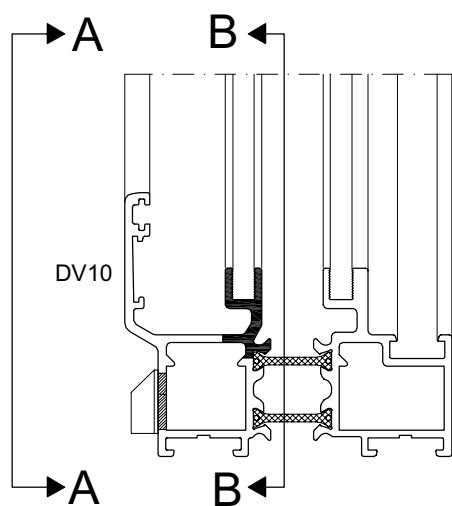

NAAR BINNEN OPENEND
OUVRANT INTERIEUR
INNEN OFFNEND
PANELS INWARDS OPENING

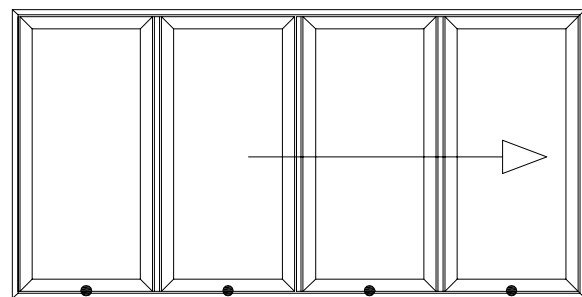
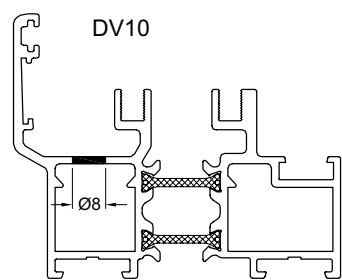
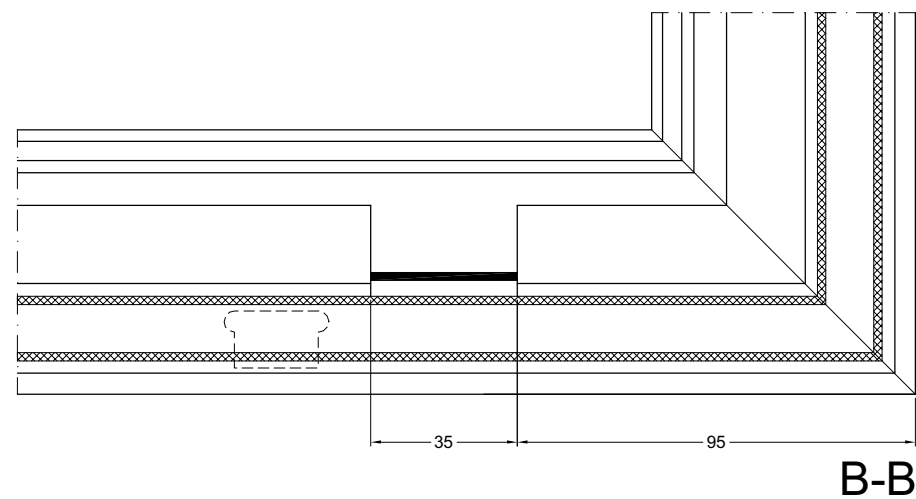
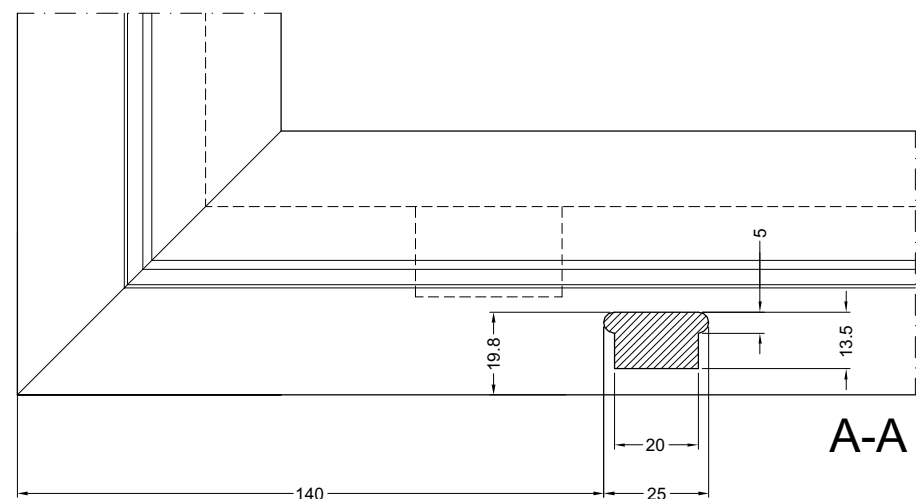

Ontluchting glassponning
Ventilation feuillure
Entlüftung Glasfälze
Ventilation glass groove

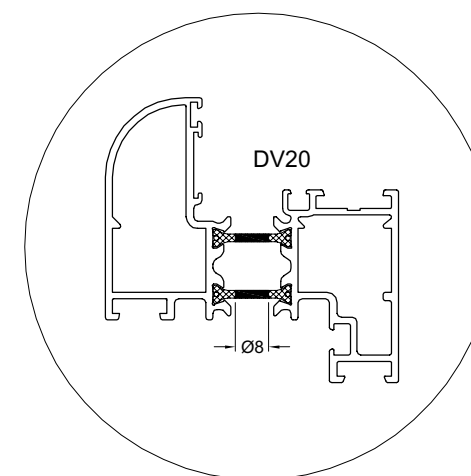

Toe te passen op ALLE vleugels
Appliquer à TOUS les ouvrants
Anwenden auf ALLE Flügel
Apply to ALL vents

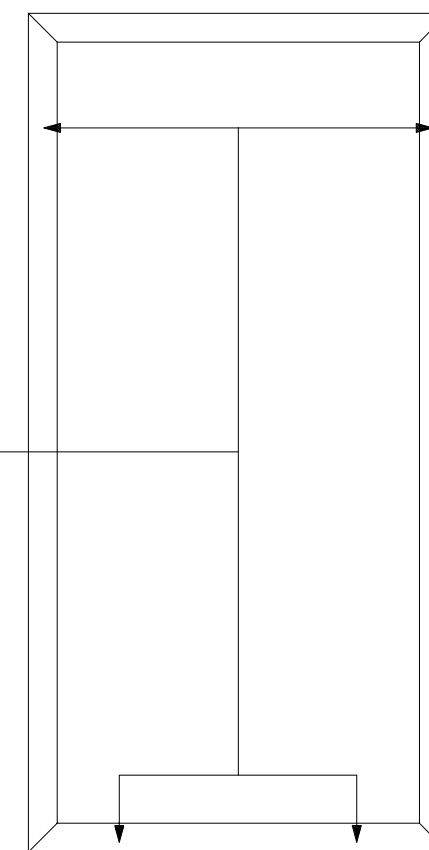

ONTWATERING - NAAR BUITEN OPENEND
EVACUATION D'EAU - OUVRANT EXTERIEUR
ENTWASSERUNG - AUSSEN OFFNEND
WATER EVACUATION - PANELS OUTWARDS OPENING

WERKTEKENINGEN - DESSINS DE CONSTRUCTION - KONSTRUKTIONZEICHNUNGEN - CONSTRUCTION DRAWINGS

NAAR BUITEN OPENEND
OUVRANT EXTERIEUR
AUSSEN OFFNEND
PANELS OUTWARDS OPENING

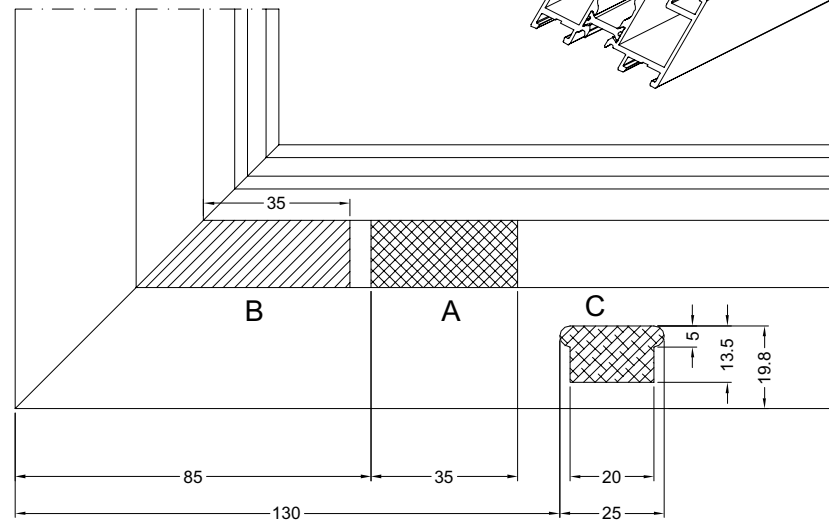
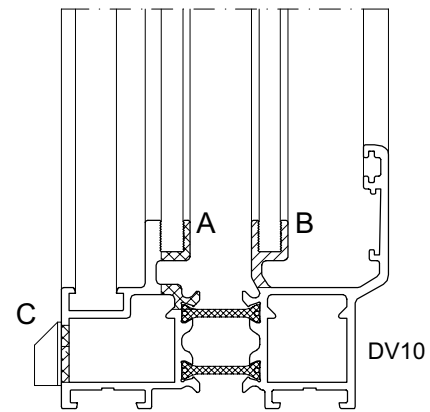
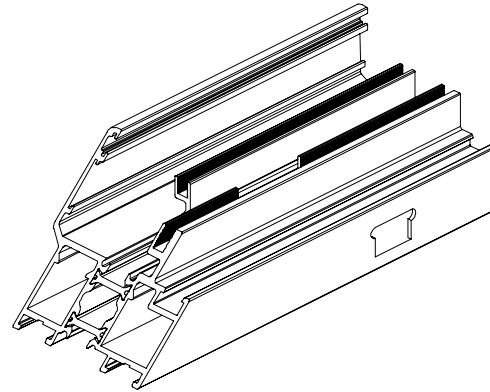

Ontwatering buitenkader
Drainage dormant
Entwässerung Rahmen
Drainage outer frame

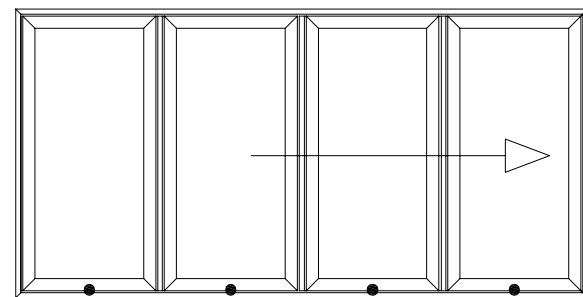
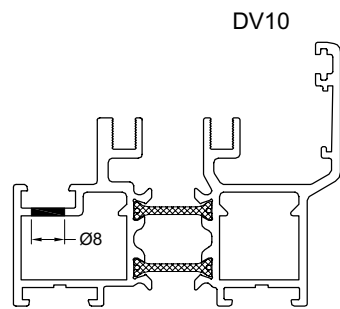
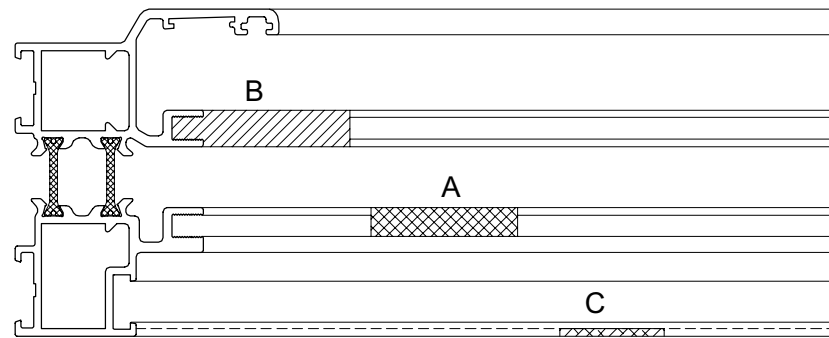

Ontluchting glassponning
Ventilation feuillure
Entlüftung Glasfälze
Ventilation glass groove

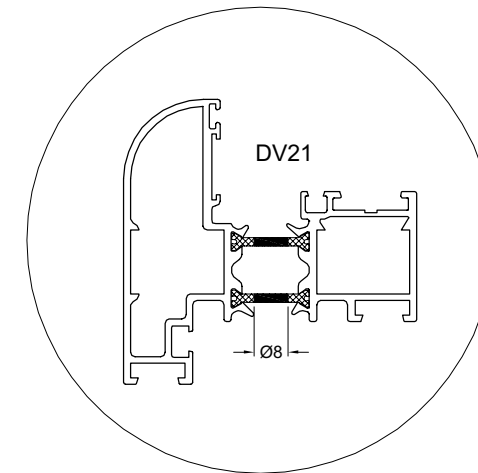

Toe te passen op ALLE vleugels
Appliquer à TOUS les ouvrants
Anwenden auf ALLE Flügel
Apply to ALL vents

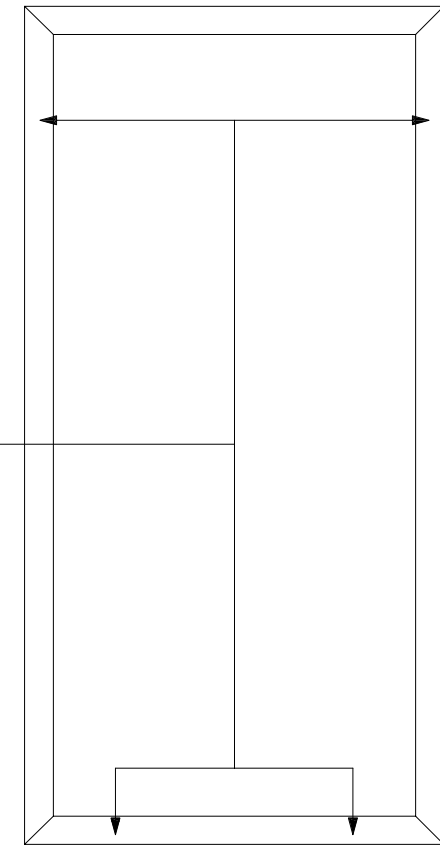

DRIEDELIGE VOEWDEUR BINNENDRAAIEND (TYPE 1i)
PORTE AMOVIBLE TROIS VANTAUX INTERIEUR (TYPE 1i)
FALT TURE, DREI FACH, INNEN DREHEND (TYPE 1i)
FOLDING DOOR WITH THREE PANELS INWARDS (TYPE 1i)

MET CYLINDERSLOT
AVEC SERRURE A CILINDRE
MIT ZYLINDERSCHLOSS
WITH SECURITY LOCK

MET GEWONE DORPEL
AVEC SEUIL
MIT SCHWELLE
WITH THRESHOLD

WERKTEKENINGEN - DESSINS DE CONSTRUCTION - KONSTRUKTIONZEICHNUNGEN - CONSTRUCTION DRAWINGS

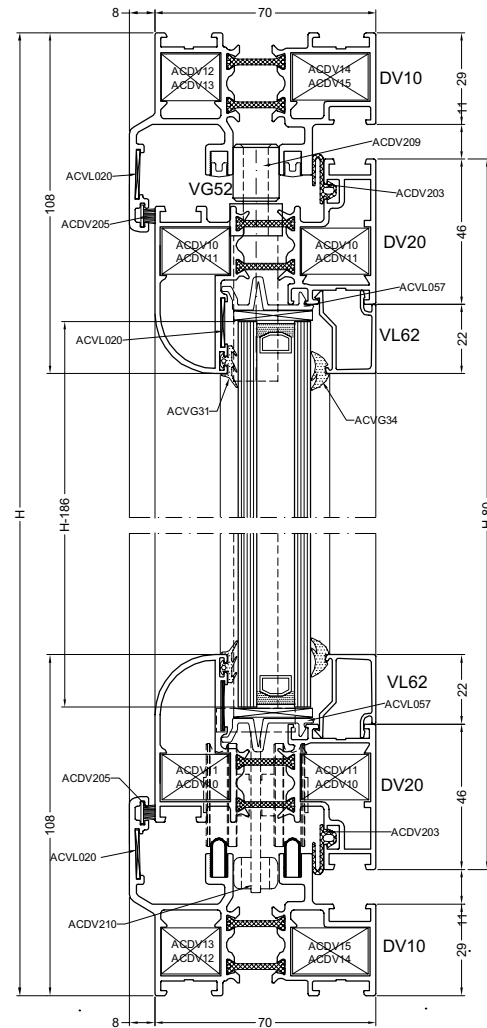

TOEBEHOREN ACCESSOIRES
ZUBEHOERTEILE ACCESSORIES

ACDV12/13	4
ACDV14/15	4
ACDV10/11	24
ACDV206	4
ACDV208	20
ACDV209	1
ACDV210	1
ACDV211	1
ACDV212	1
ACDV213	2
ACDV214	1set
ACDV720	1
ACDV725	1
ACDV118	1
ACVL020	16
ACVL057	24
ACDV205	2H+2B
ACDV202	20H
ACDV203	6H+2B-1M
ACVG31	6H+2B-1M
ACVG3*	6H+2B-1M
ACVG45	2
ACFA120	2
ACFA121	1/5
ACMX862	1/5
ACMX309	1
ACDV215	1

PROFIELN PROFILES PROFILE PROFILS

DV10		2		B
DV10		2		H
DV20		6		B/3 -65
DV20		6		H-80
DV31		2		H-80
DV52		1		H-80
DV52		1		H-110
VG53		2		B-90
VL6*		6		B/3 -157
VL6*		6		H-216
VG52		2		B-90
VG52		4		H-90

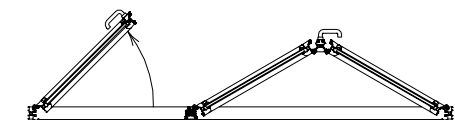
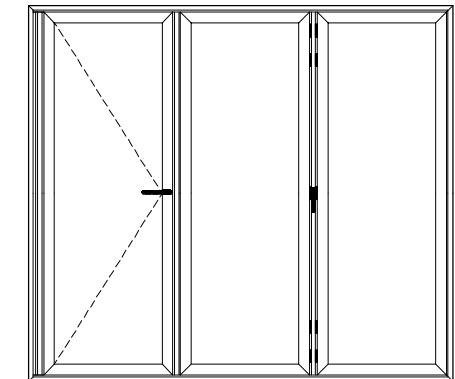

GLASMATEN DIMENSIONS DES VITRAGES GLASSMASSE GLASS SIZES	3 X	B/3 - 171 H - 186
---	-----	----------------------

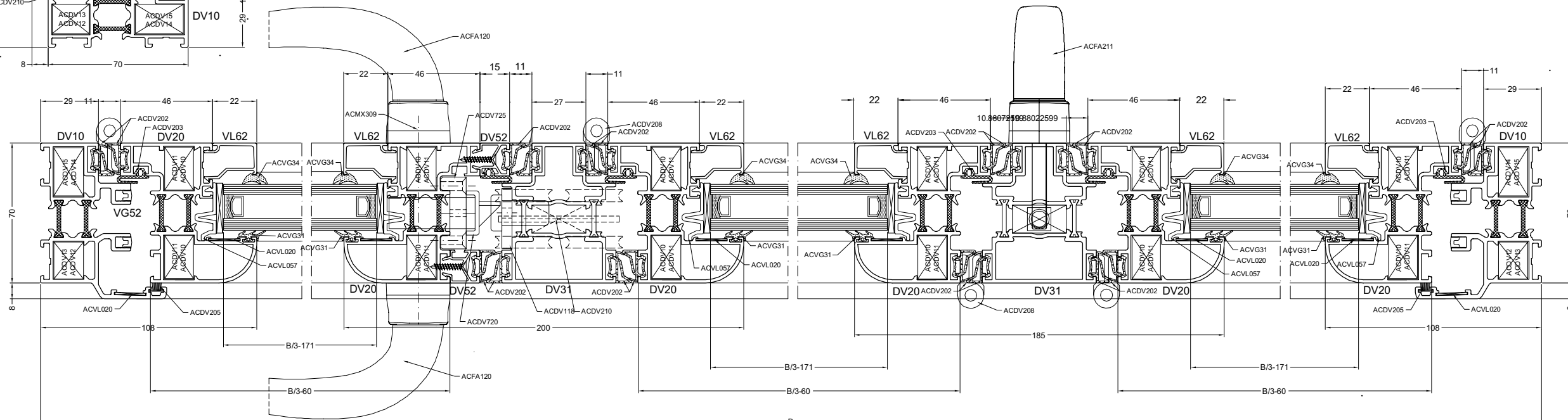

VIERDELIGE VOEUWDEUR BINNENDRAAIEND (TYPE 3i)
PORTE AMOVIBLE QUATRE VANTAUX INTERIEUR (TYPE 3i)
FALT TURE, 4 FACH, INNEN DREHEND (TYPE 3i)
FOLDING DOOR WITH FOUR PANELS INWARDS (TYPE 3i)

MET CYLINDERSLOT
AVEC SERRURE A CILINDRE
MIT ZYLINDERSCHLOSS
WITH SECURITY LOCK

MET GEWONE DORPEL
AVEC SEUIL
MIT SCHWELLE
WITH THRESHOLD

WERKTEKENINGEN - DESSINS DE CONSTRUCTION - KONSTRUKTIONZEICHNUNGEN - CONSTRUCTION DRAWINGS

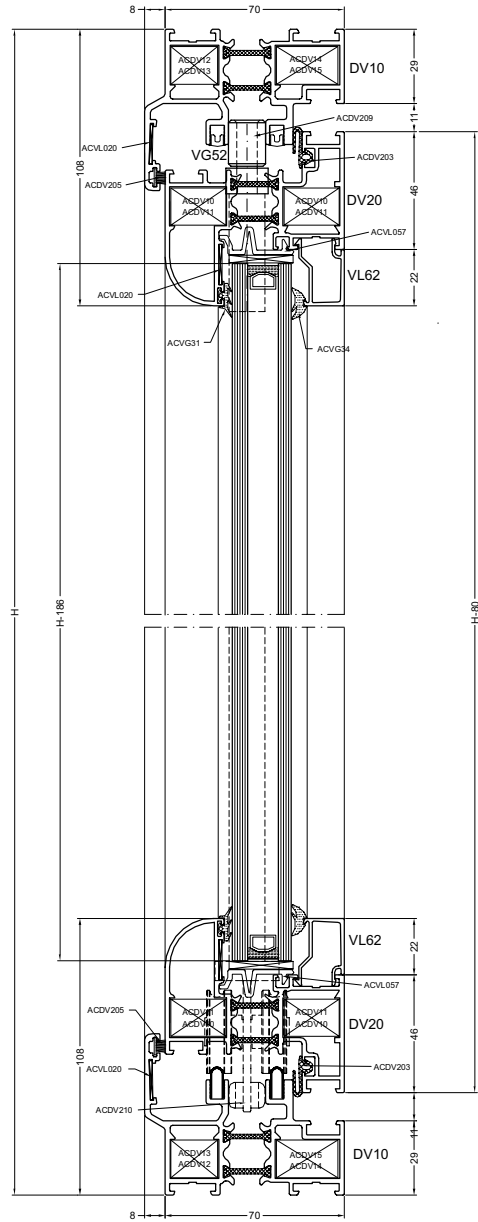

TOEBEHOREN ACCESSOIRES
ZUBEHORTEILE ACCESSORIES

ACDV12/13	4
ACDV14/15	4
ACDV10/11	32
ACDV206	8
ACDV208XX	32
ACDV209	2
ACDV210	2
ACFA211	2
ACDV212	2
ACDV213	4
ACDV214	2sets
ACVL020	20
ACVL057	32
ACDV205	2H+2B
ACDV202	32H
ACDV203	9H+2B-1.3m
ACVG31	8H+2B-1.3m
ACVG3*	8H+2B-1.3m
ACVG45	2

PROFIELEN PROFILES PROFILE PROFILS

DV10		2		B
DV10		2		H
DV20		8		B/4 -74
DV20		8		H-80
DV31		4		H-80
DV52	*	2		H-80
VG53	∩	2		B-90
VL6*	∩	8		B/4 -166
VL6*	∩	8		H-216
VG52	*	2		B-90
VG52	*	4		H-90

GLASMATEN DIMENSIONS DES VITRAGES GLASMASSE GLASS SIZES	4 X	B/4 - 180 H - 186
--	-----	----------------------

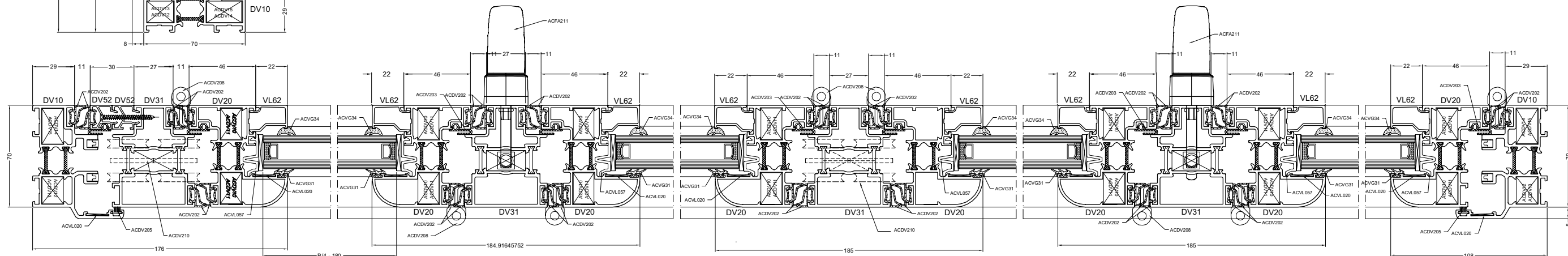
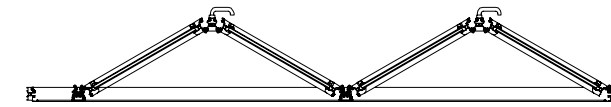
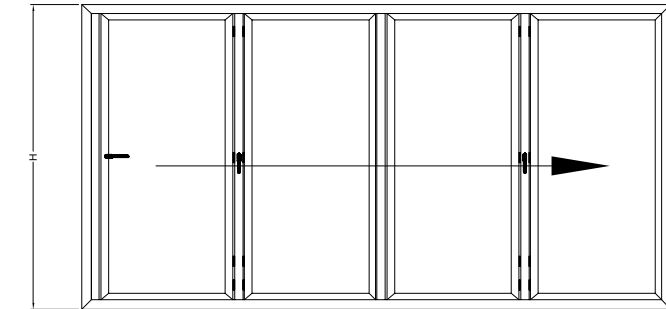

AFMETING VLEUGELS (OPEN VOUWDEUR)
ENCOMBREMENT VANTAUX (PORTE OUVERTE)
UBERFÜLLUNG FLUGEL (TUR OFFEN)
SASH DIMENSION (OPEN DOOR)

WERKTEKENINGEN - DESSINS DE CONSTRUCTION - KONSTRUKTIONZEICHNUNGEN - CONSTRUCTION DRAWINGS

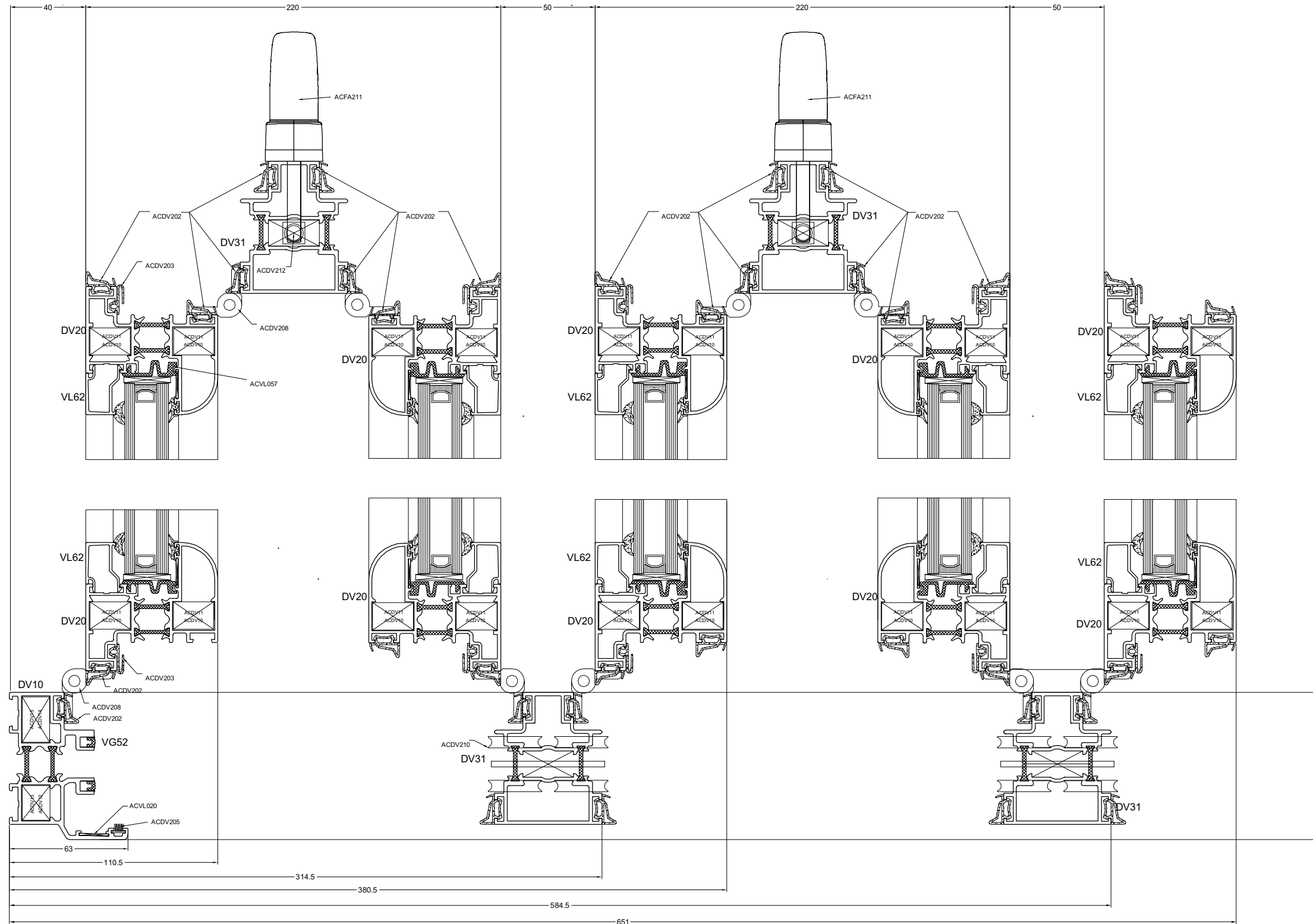

werkt14

MONTAGE DV70 OP DV10
MONTAGE DV70 SUR DV10
MONTAGE DV70 AUF DV10
MONTAGE DV70 ON DV10

WERKTEKENINGEN - DESSINS DE CONSTRUCTION - KONSTRUKTIONZEICHNUNGEN - CONSTRUCTION DRAWINGS

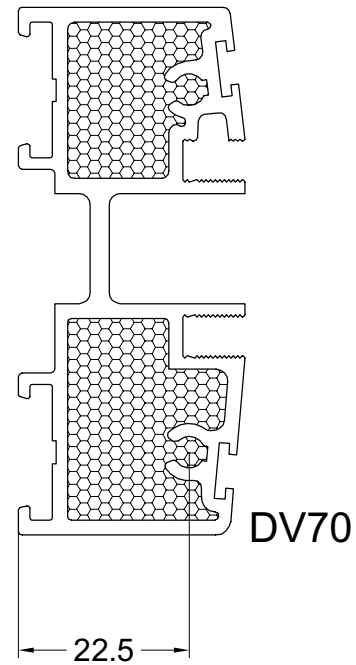
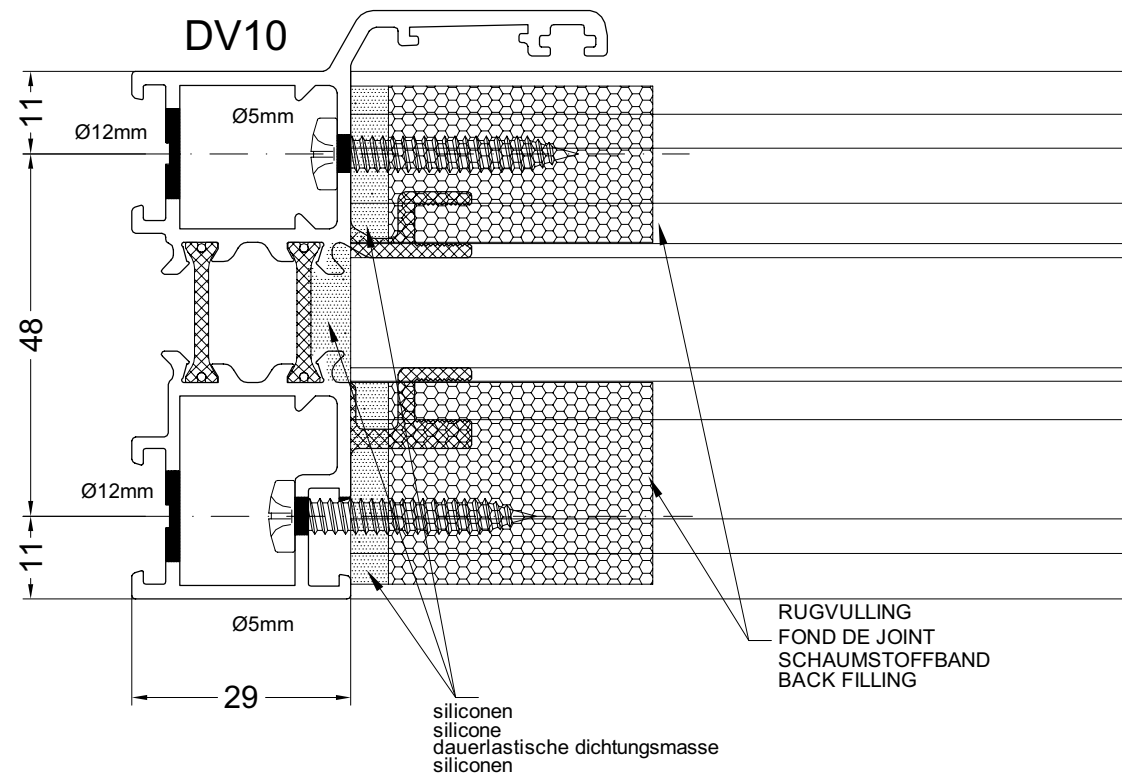
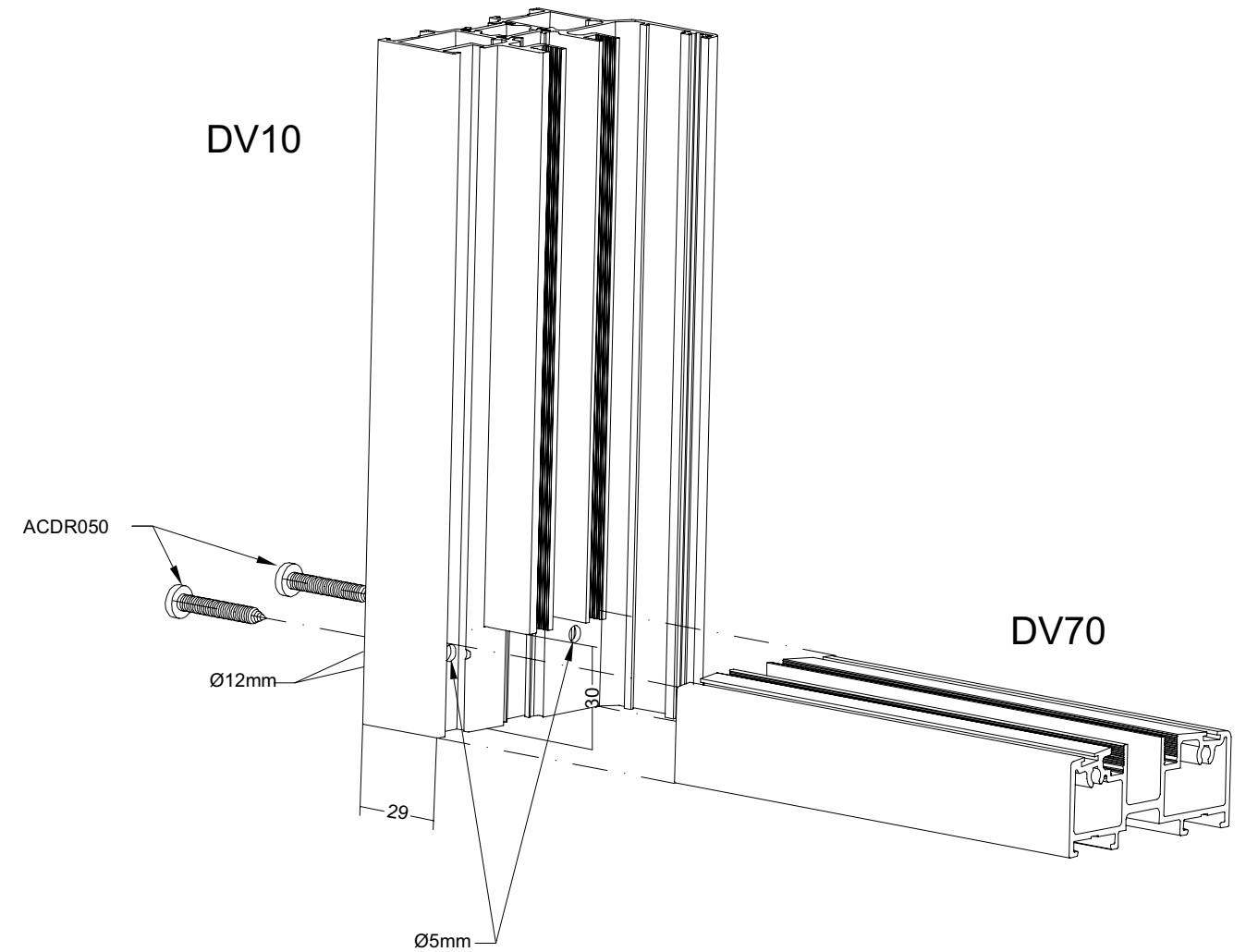
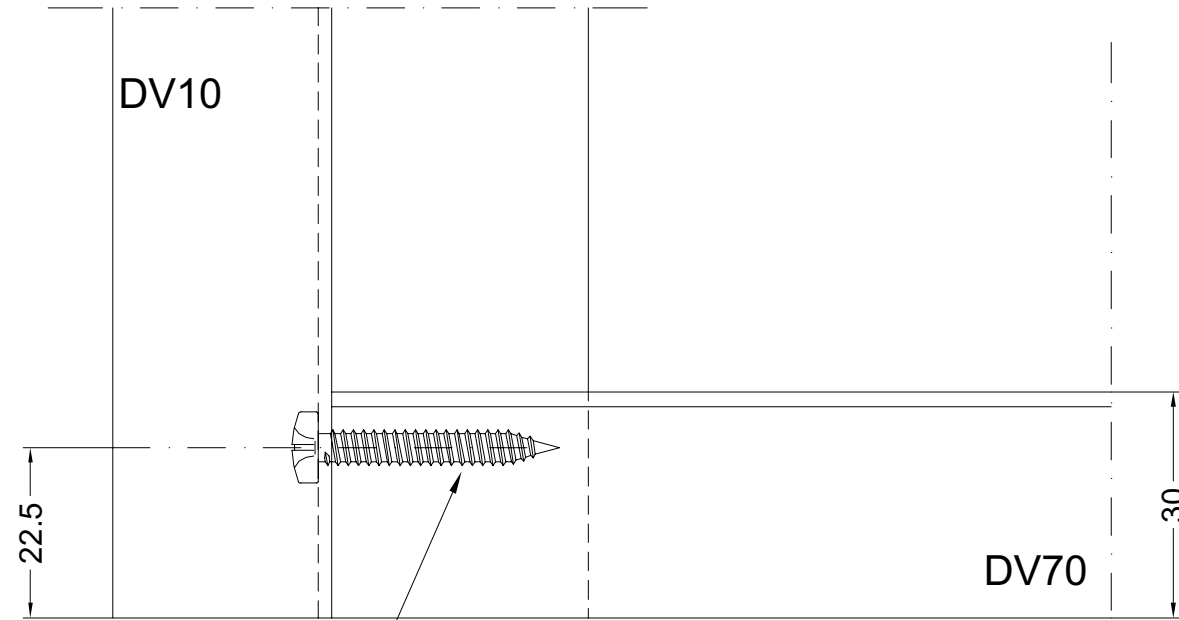

MONTAGE OPSCHROEFSCHARNIER ACDV208
MONTAGE CHARNIERE A VISSER ACDV208
MONTAGE BAND ZUM SCHRAUBEN ACDV208
MONTAGE HINGE WITH SCREW FITTING ACDV208

WERKTEKENINGEN - DESSINS DE CONSTRUCTION - KONSTRUKTIONZEICHNUNGEN - CONSTRUCTION DRAWINGS

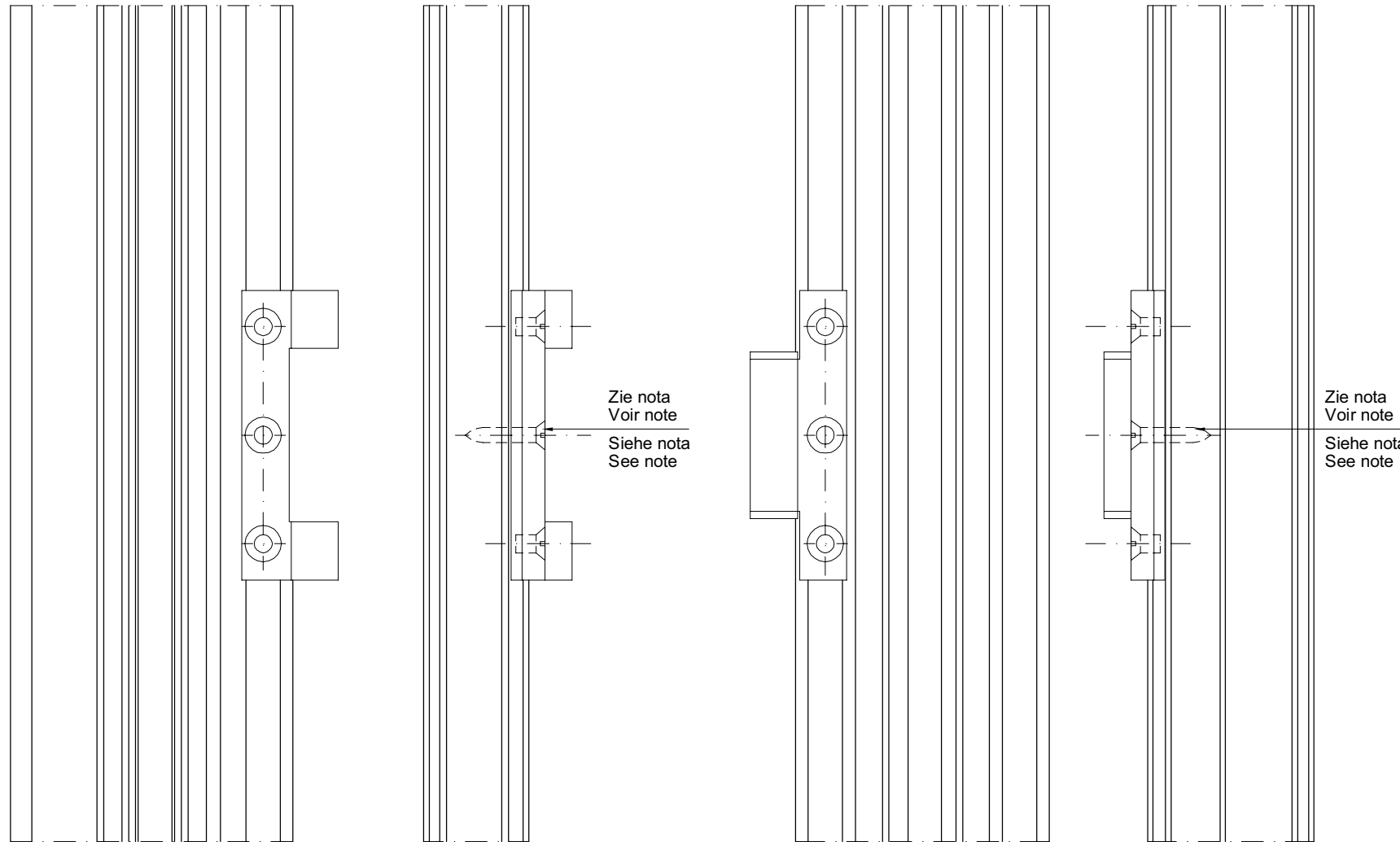

NOTA / NOTE:

- TE BOREN EN TE BORGEN NA REGELING V/D SCHARNIEREN
- A CONTREPERCER APRES POSITIONEMENT DES PAUMELES
- BOHREN UND ZICHEREN NACH POSITIONIERUNG DES BANDES
- TO DRILL AND FASTEN AFTER POSITIONING OF HINGES

